

MATHS

BOOKS - VK GLOBAL PUBLICATION MATHS (HINGLISH)

CIRCLES

VERY SHORT ANSWER QUESTIONS

1. If a point P is 17 cm from the centre of a circle of radius 8 cm, then find the length of the tangent drawn to the circle from point P.

Answer: 15 cm



[Watch Video Solution](#)

VERY SHORT ANSWER QUESTIONS (1 marks)

1. The length of the tangent to a circle from a point P, which is 25 cm away from the centre, is 24 cm. What is the radius of the circle.

Answer: 7 cm



Watch Video Solution

2. In Fig , ABCD is a cyclic quadrilateral . If $\angle BAC = 50^\circ$ and $\angle DBC = 60^\circ$ then find $\angle BCD$.

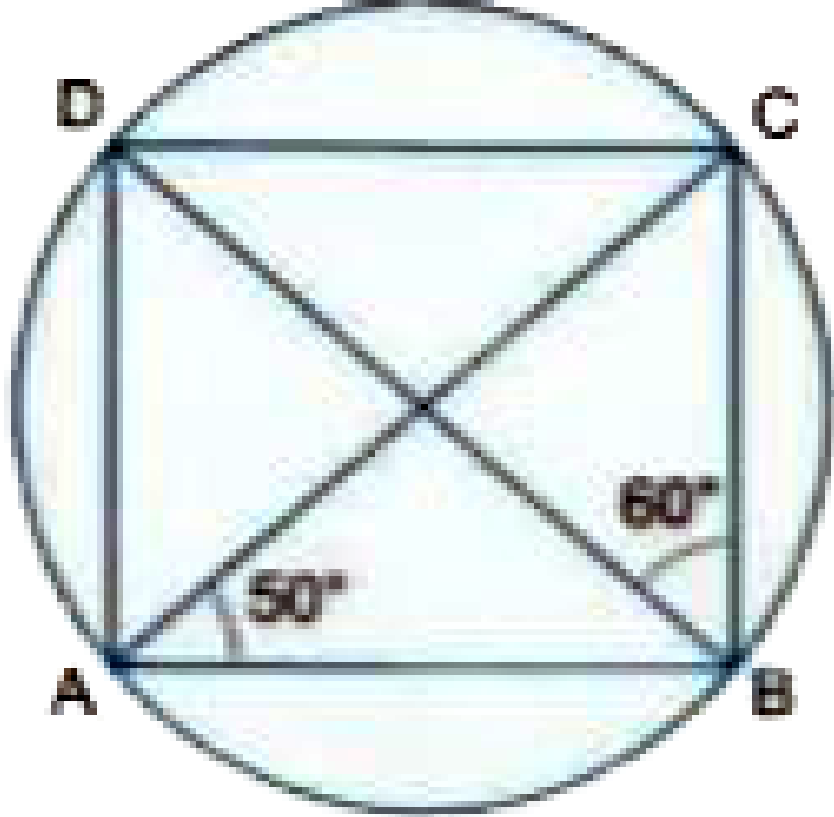

Answer: 70°

[▶ Watch Video Solution](#)

3. In Fig the quadrilateral ABCD circumscribes a circle with centre O. If $\angle AOB = 115^\circ$, then find $\angle AOB = 115^\circ$ then find $\angle COD$.

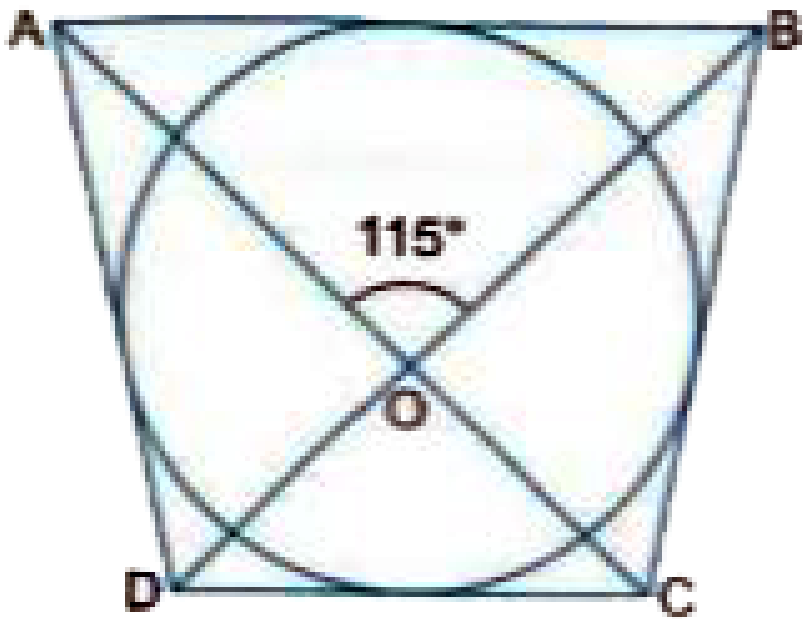

Answer: 115°



Watch Video Solution

4. In Fig , $\triangle ABC$ is circumscribing a circle. Find the length of BC.

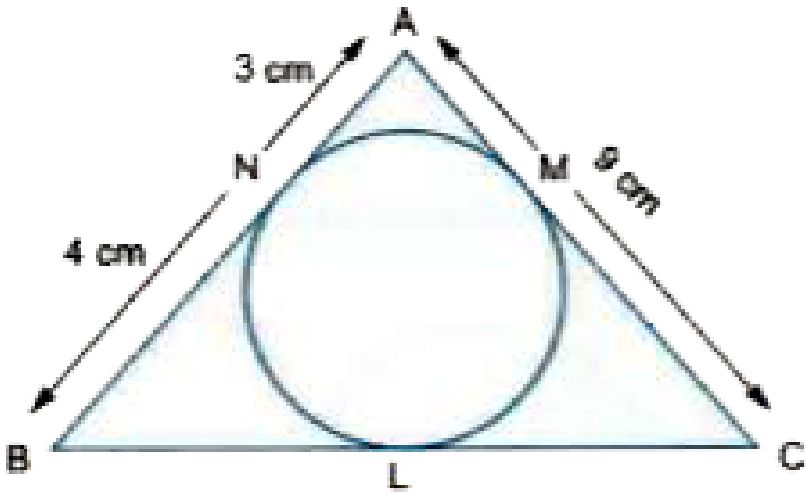

Answer: 10 cm

[▶ Watch Video Solution](#)

5. In Fig , O is the centre of a circle , PQ is a chord and the tangent PR at P makes an angle of 50° with PQ. Find $\angle POQ$.

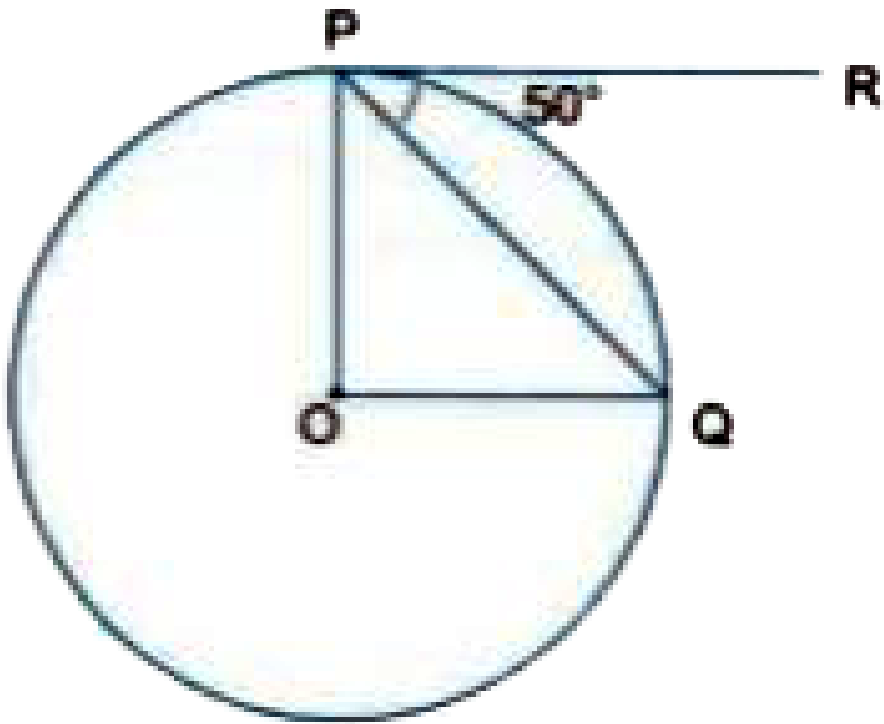

Answer: 100°

[▶ Watch Video Solution](#)

6. If two tangents inclined at an angle 60° are drawn to a circle of radius 3 cm, then find the length of each tangent.

Answer: $3\sqrt{3}$ cm

[▶ Watch Video Solution](#)

7. If radii of two concentric circles are 4 cm and 5 cm, then length of each chord of one circle which is tangent to the other circle, is

Answer: 6 cm

 [Watch Video Solution](#)

8. PQ is a tangent drawn from a point P to a circle with centre O and QOR is a diameter of the circle such that $\angle POR = 120^\circ$, then $\angle OPQ$ is 60° (b) 45° (c) 30° (d) 90°

Answer: 30°

 [Watch Video Solution](#)

9. From the external point P tangents PA and PB are drawn to a circle with centre O . If $\angle PAB = 50^\circ$, then find $\angle AOB$.

Answer: 100°

 [Watch Video Solution](#)

10. PQ is a tangent at a point C to a circle with centre O if AB is a diameter and angle $CAB = 30^\circ$, find angle PCA .

Answer: 60°

 [Watch Video Solution](#)

SHORT ANSWER QUESTIONS - I (2 marks)

1. AB is a diameter of a circle and AC is its chord such that $\angle BAC = 30^\circ$. If the tangent at C intersects AB extended at D, then $BC=BD$.

Answer: True

 [Watch Video Solution](#)

2. The length of tangent from an external point P on a circle with centre O is always less than OP.

Answer: True

 [Watch Video Solution](#)

3. If angle between two tangents drawn from a point P to a circle of radius a and centre O is 90° then $OP = a\sqrt{2}$.

Answer: True



Watch Video Solution

4. In the given figure, PA and PB are tangents to the circle from an external point P. CD is another tangent touching the circle at Q. If PA = 12 cm, QC = 3 cm, then find PC + PD.

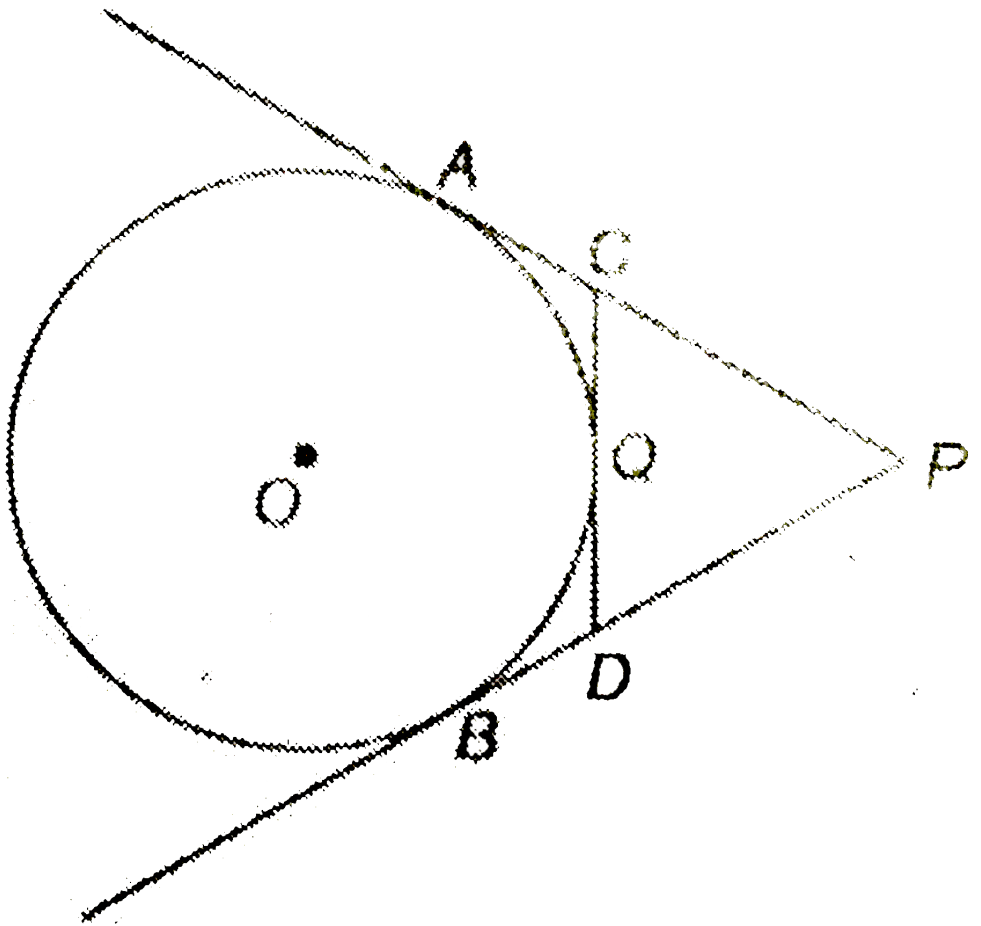

Answer: 30 cm

[▶ Watch Video Solution](#)

5. Prove that the line segment joining the points of contact of two parallel tangents of a circle, passes through its centre.



[Watch Video Solution](#)

6. If from an external point P of a circle with centre O, two tangents PQ and PR are drawn such that $\angle QPR = 120^\circ$, prove that $2PQ = PO$.



[Watch Video Solution](#)

7. In Fig common tangents AB and CD to two circles with centres O_1 and O_2 intersect at E. Prove that $AB = CD$.

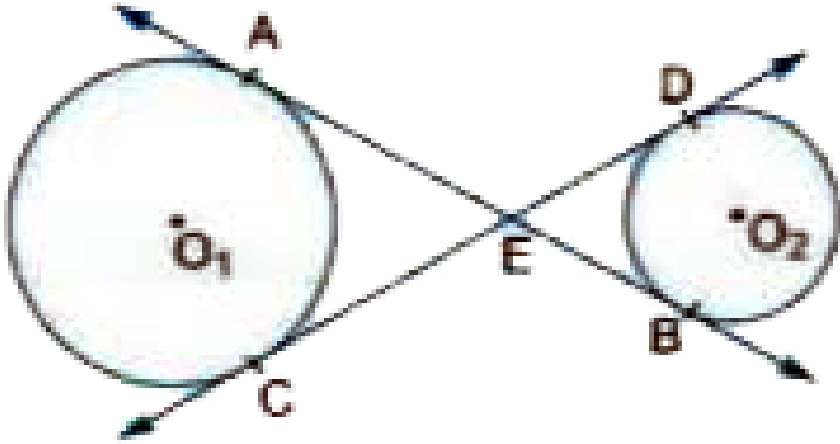

[▶ Watch Video Solution](#)

8. The incircle of an isosceles triangle ABC , in which $AB = AC$, touches the sides BC , CA and AB at D , E and F

respectively . Prove that $BD = DC$.

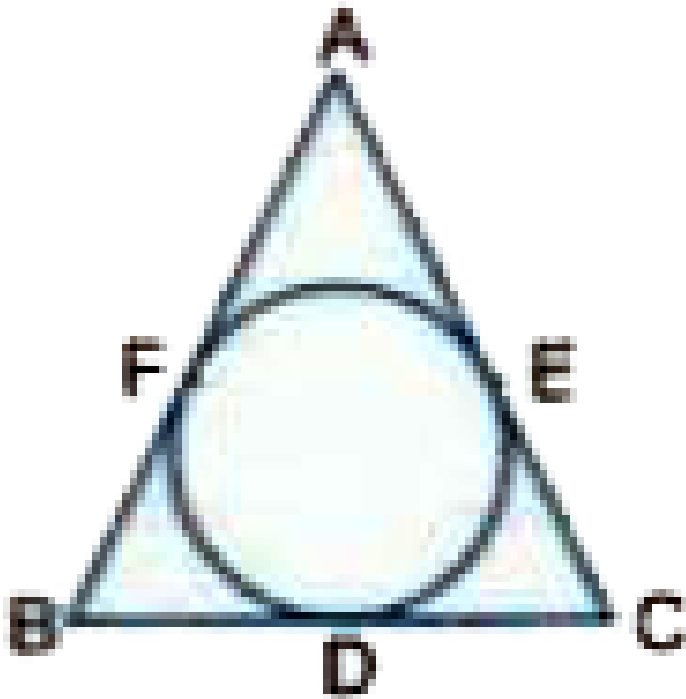

[▶ Watch Video Solution](#)

9. In Fig , XP and XQ are two tangents to the circle with centre O , drawn from an external point X . ARB is another tangent, touching the circle at R . Prove that $XA + AR = XB$

+ BR.

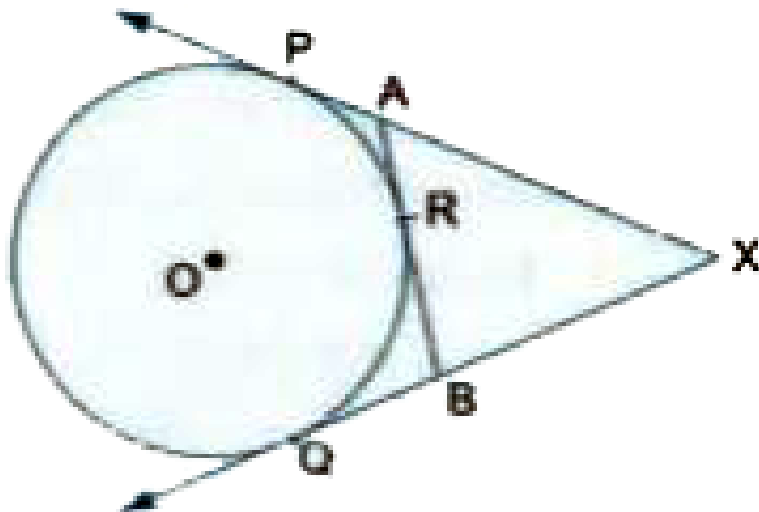

[▶ Watch Video Solution](#)

10. In the given figure, a circle inscribed in a triangle ABC, touches the sides AB, BC and AC at points D, E and F respectively. If $AB = 12$ cm, $BC = 8$ cm and $AC = 10$ cm, find the lengths of AD, BE and CF.

Answer: $AD = 7$ cm , $BE = 5$ cm , $CF = 3$ cm

[▶ Watch Video Solution](#)

11. In Fig.2, a quadrilateral ABCD is drawn to circumscribe a circle, with centre O, in such a way that the sides AB, BC, CD and DA touch the circle at the points P, Q, R and S respectively. Prove that $AB + CD = BC + DA$.



Watch Video Solution

12. In Fig AP and BP are tangents to a circle with centre O, such that $AP = 5 \text{ cm}$, and $\angle APB = 60^\circ$. Find the length of chord AB.

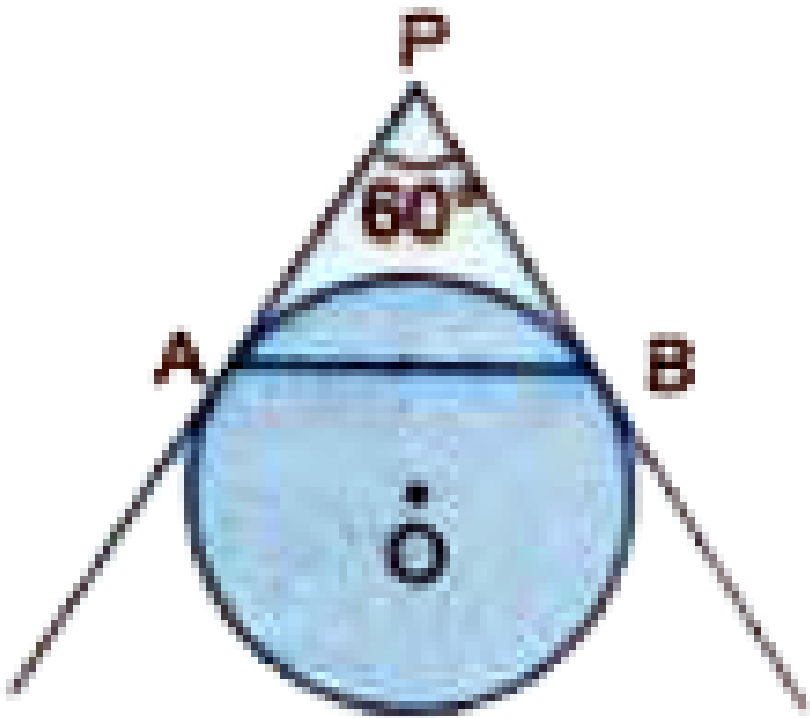

Answer: 5 cm

[▶ Watch Video Solution](#)

13. From an external point P, two tangents PT and PS are drawn to a circle with centre O and radius r. if $OP=2r$, show that $\angle OTS = \angle OST = 30^\circ$

Answer: 30°

 Watch Video Solution

14. In Fig , are two concentric circles of radii 6 cm and 4 cm with centre O . If AP is a tangent to the larger circle and BP to the smaller circle and length of AP is 8 cm, find the length of BP.

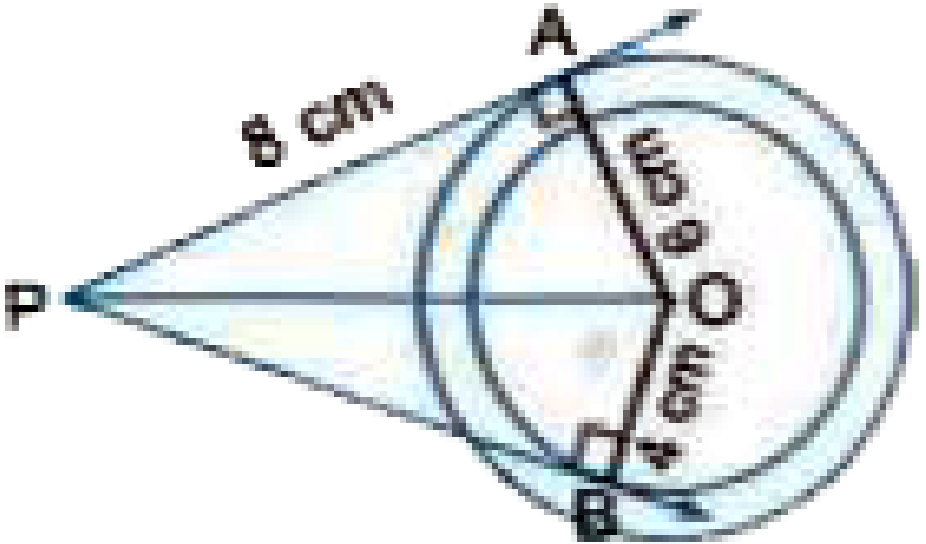

Answer: $2\sqrt{21}$ cm

 Watch Video Solution

SHORT ANSWER QUESTIONS - II (3 marks)

1. Tangent PQ at a point P of a circle of radius 5 cm meets a line through the centre O at a point Q so that OQ = 12 cm. Find length of PQ

Answer: $\sqrt{119}$ cm



[Watch Video Solution](#)

2. The length of the tangent to a circle from a point P, which is 25 cm away from the centre, is 24 cm. What is the radius of the circle.

Answer: 7 cm



[Watch Video Solution](#)

3. In Fig. 10.11, if TP and TQ are the two tangents to a circle with centre O so that $\angle POQ = 110^\circ$, then $\angle PTQ$ is equal to

Answer: 70°

 [Watch Video Solution](#)

4. Prove that the tangents drawn at the ends of a diameter of a circle are parallel.

 [Watch Video Solution](#)

5. If tangents PA and PB from a point P to a circle with centre O are inclined to each other at angle of 80° , then find $\angle POA$.

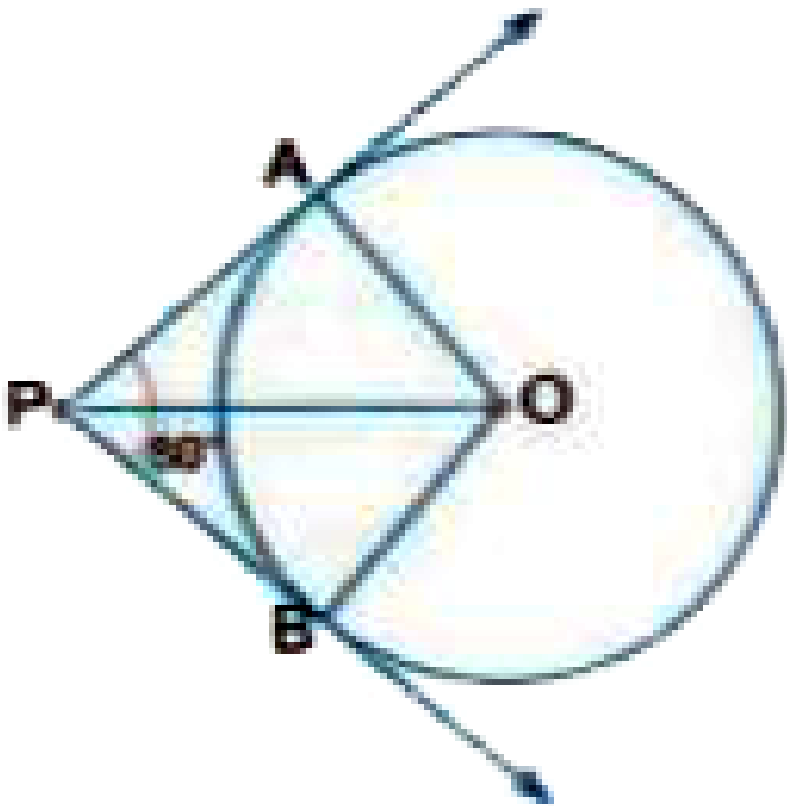

Answer: 50°

[▶ Watch Video Solution](#)

6. The length of a tangent from a point A at distance 5 cm from the centre of the circle is 4 cm . Find the radius of the circle.

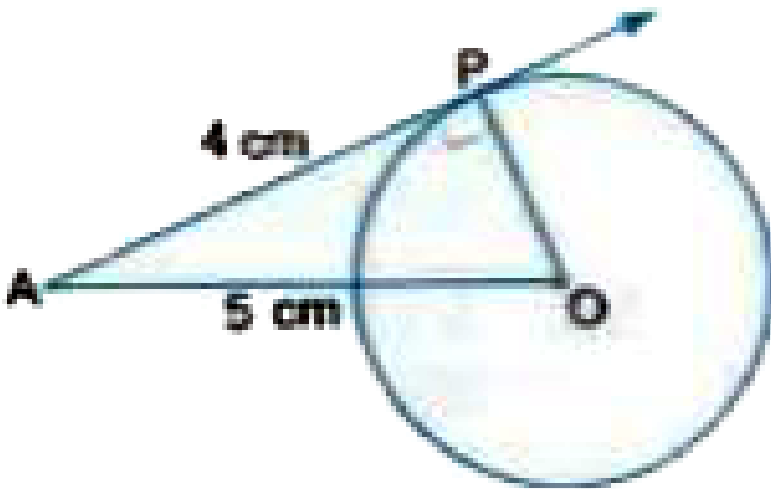

Answer: the radius of the circle is 3 cm

[▶ Watch Video Solution](#)

7. Two concentric circles are of radii 5 cm and 3 cm. Find the length of the chord of the larger circle which touches the smaller circle.

Answer: 8 cm

[▶ Watch Video Solution](#)

8. Prove that the tangents drawn at the end points of a chord of a circle make equal angles with the chord.

 [Watch Video Solution](#)

9. Prove that the perpendicular at the point of contact to the tangent to a circle passes through the centre.

 [Watch Video Solution](#)

10. A quadrilateral ABCD is drawn to circumscribe a circle.

Prove that $AB + CD = AD + BC$

 [Watch Video Solution](#)

11. Type II: A circle is touching the side BC of $\triangle ABC$ at P and touching AB and AC produced at Q and R respectively

Prove that $AQ = \frac{1}{2}(\text{Perimeter of } \triangle ABC)$

[▶ Watch Video Solution](#)

12. In Fig , if $AB = AC$, prove that $BE = EC$.

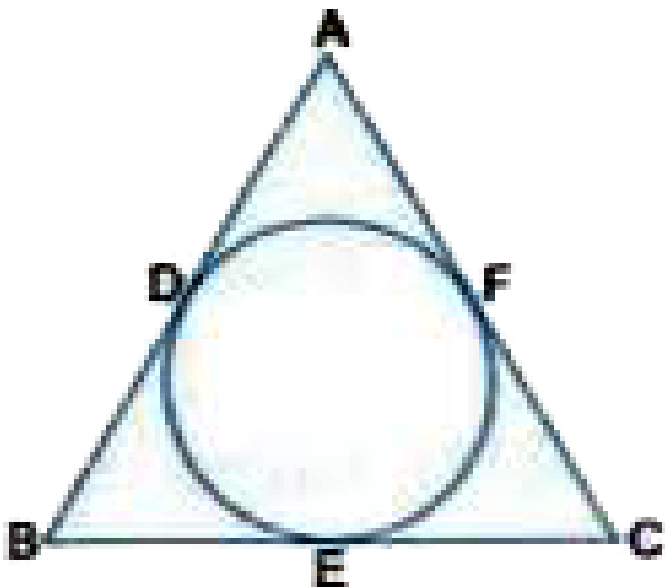

[▶ Watch Video Solution](#)

13. A circle is inscribed in a $\triangle ABC$ having sides 8 cm, 10 cm and 12 cm as shown in figure. Find AD, BE and CF.

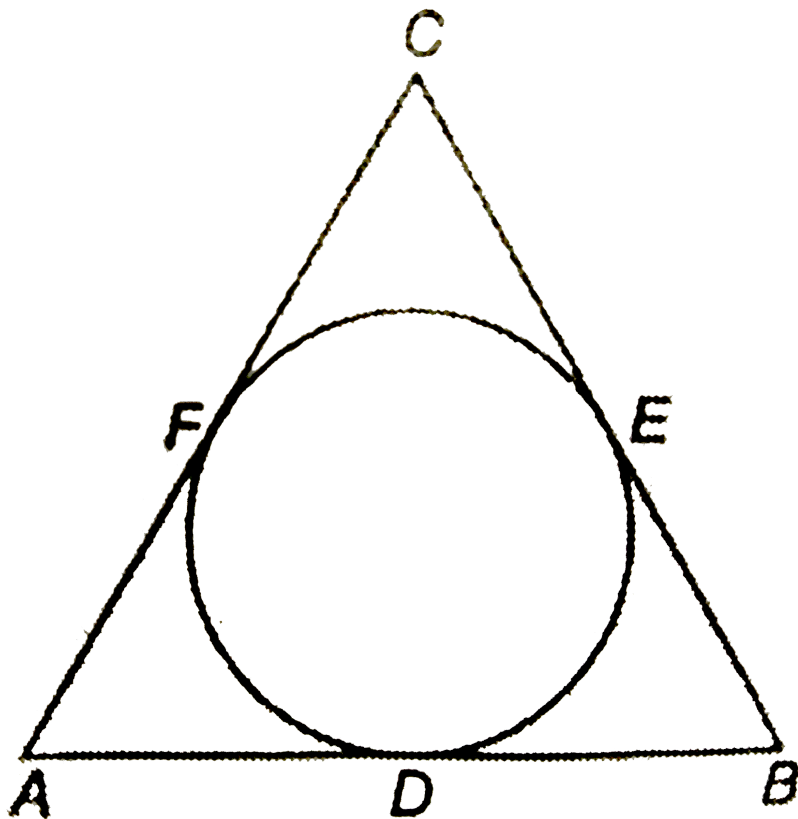

Answer:

$AD = x = 7\text{cm}$, $BE = y = 5\text{cm}$ and $CF = z = 3\text{cm}$



[Watch Video Solution](#)

LONG ANSWER QUESTIONS (4 marks)

1. Theorem: A tangent to a circle is perpendicular to the radius through the point of contact.



[Watch Video Solution](#)

2. Prove that the length of the tangents drawn from an external point to a circle are equal.



[Watch Video Solution](#)

3. Prove that the parallelogram circumscribing a circle is a rhombus.

 Watch Video Solution

4. In Fig , PQ is a chord of length 16 cm, of a radius 10 cm . The tangents at P and Q intersect at a point T. Find the length of TP.

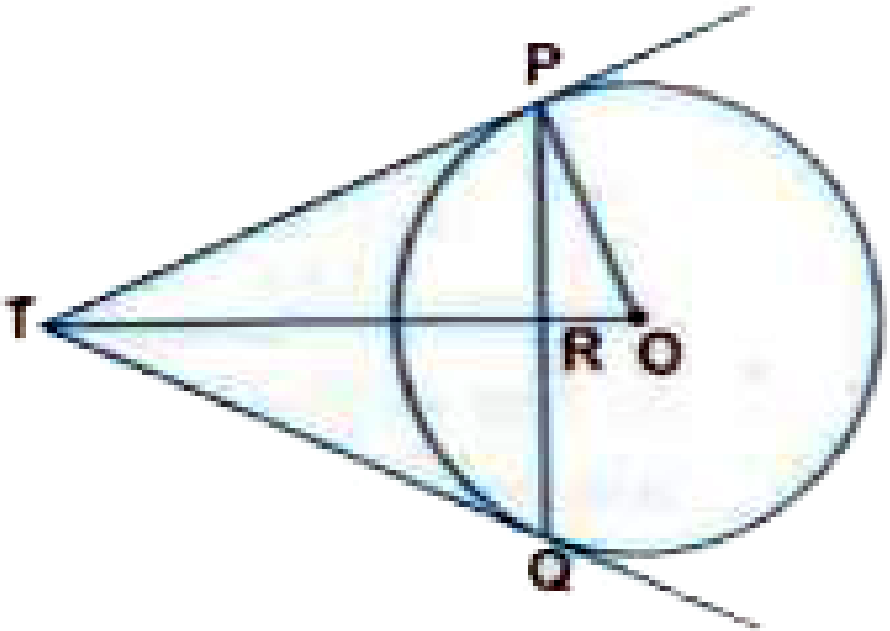

Answer: 7.5 cm

 Watch Video Solution

5. PQ is a tangent drawn from a point P to a circle with centre O and QOR is a diameter of the circle such that $\angle POR = 120^\circ$, then $\angle OPQ$ is 60° (b) 45° (c) 30° (d) 90°

Answer: $PO = 8 \text{ cm}$, $PQ = 4\sqrt{3}$

 [Watch Video Solution](#)

6. . In the given figure, two equal circles, with centres O and O' , touch each other at X . OO' produced meets the circle with centre O' at A . AC is tangent to the circle with centre O , at the point C . $O'D$ is perpendicular to AC . Find the value of $\frac{DO'}{CO}$.

Answer: $\frac{1}{3}$

 [Watch Video Solution](#)

7. O is the centre of a circle of radius 5cm . T is a point such that $OT = 13\text{cm}$ and OT intersects the circle at E . If AB is the tangent to the circle at E , find length of AB .

Answer: 6.6 cm

 [Watch Video Solution](#)

HOTS (Higher Order Thinking Skills)

1. Prove that opposite sides of a quadrilateral circumscribing a circle subtend supplementary angles at the centre of the circle.

 [Watch Video Solution](#)

2. A triangle ABC is drawn to circumscribe a circle of radius 4 cm such that the segments BD and DC into which BC is divided by the point of contact D are of lengths 8 cm and 6 cm respectively. Find the sides AB and AC.

Answer: AB = 15 cm , AC = 13 cm

 [Watch Video Solution](#)

3. In Fig. 10.13, XY and $X'Y'$ are two parallel tangents to a circle with centre O and another tangent AB with point of contact C intersecting XY at A and $X'Y'$ at B. Prove that $\angle AOB = 90^\circ$

 [Watch Video Solution](#)

4. Let A be one point of intersection of two intersecting circles with centres O and Q . The tangents at A to the two circles meet the circles again at B and C , respectively. Let the point P be located so that $AOPQ$ is a parallelogram. Prove that P is the circumcentre of the triangle ABC .



[Watch Video Solution](#)

PROFICIENCY EXERCISE (Very Short Answer Questions 1 mark)

1. The length of the tangent to a circle from a point P , which is 25 cm away from the centre, is 24 cm. What is the radius of the circle.

Answer: 10 cm



[Watch Video Solution](#)

2. At one end A of a diameter AB of a circle of radius 13 cm , tangent ,XAY is drawn to the circle . A chord CD is parallel to XY and is at a distance of 18 cm from A . What will be the length of CD?

Answer: 24 cm



[Watch Video Solution](#)

3. If radii of two concentric circles are 12 cm and 13 cm, find the length of each chord of one circle which is tangent to the other circle.

Answer: 10 cm



[Watch Video Solution](#)

4. From a point A which is at a distance of 10 cm from the centre O of radius 6 cm, the pair of tangents AB and AC to the circle are drawn. What will be the area of the quadrilateral ABOC?

Answer: 48cm^2



Watch Video Solution

5. In Fig , $\triangle ABC$ is circumscribing a circle . Find the length of AB.

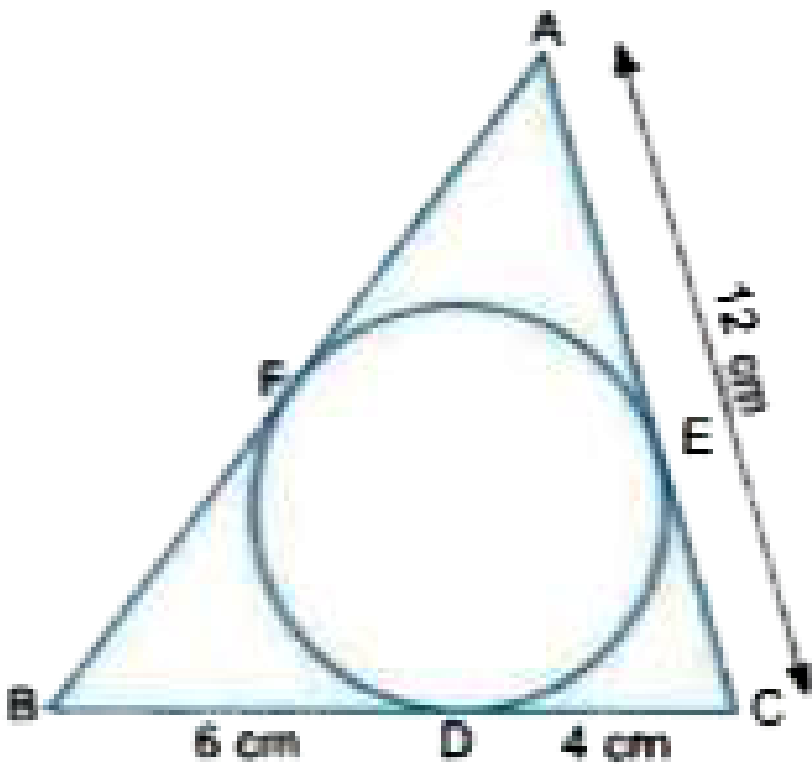

Answer: 14 cm

[▶ Watch Video Solution](#)

6. In fig. PQ is a tangent to length 6cm to the circle with centre O and $\angle OQP = 60^\circ$. Find OQ

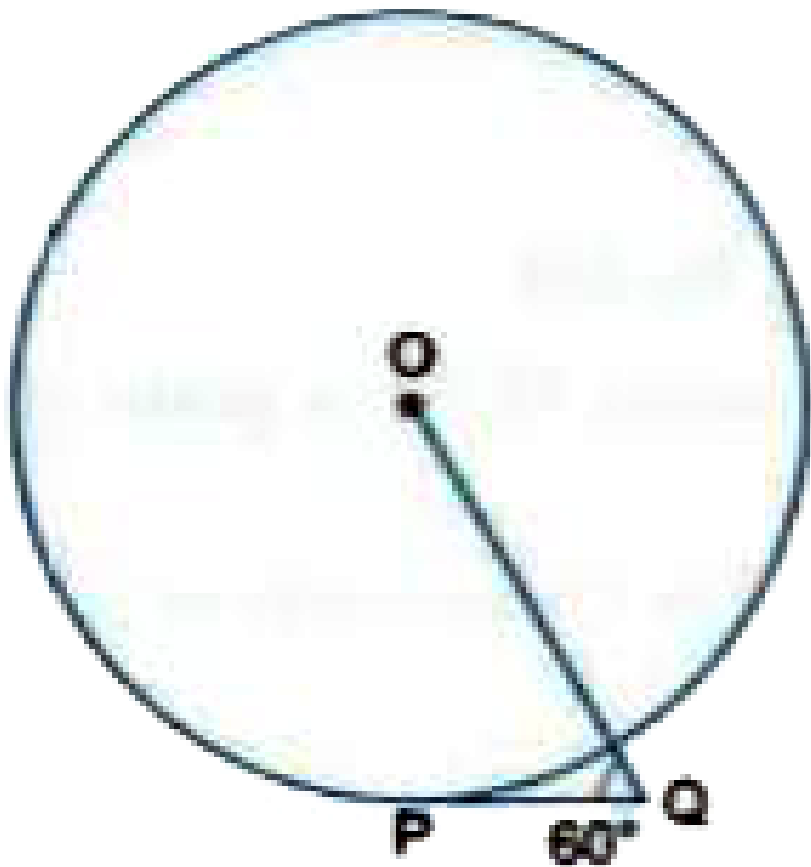

Answer: 12 cm

[▶ Watch Video Solution](#)

7. Two equal circles touch each other externally at C and AB is a common tangent to the circles. Then, $\angle ACB =$

60° (b) 45° (c) 30° (d) 90°

Answer: 90°



Watch Video Solution

8. If tangents PA and PB from a point P to a circle with centre O are inclined to each other at an angle of 110° , find $\angle POA$.

Answer: 35°



Watch Video Solution

9. If angle between two radii of a circle is 80° , what will be the angle between the tangents at the ends of the radii

?

Answer: 100°

[▶ Watch Video Solution](#)

10. In fig AB is chord of a circle with centre O and AP is the tangent at A such that $\angle BAP = 75^\circ$ find $\angle ACB$

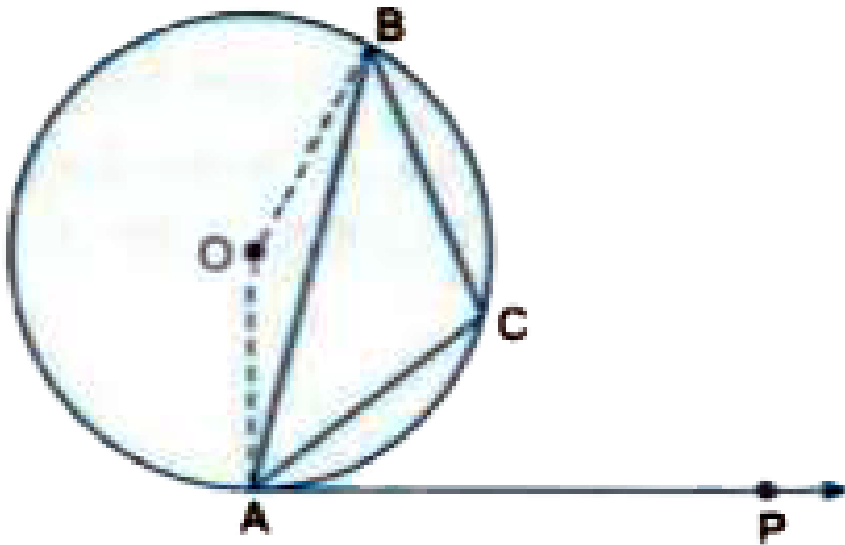

Answer: 105°

[▶ Watch Video Solution](#)

11. In Fig if $\angle AOB = 125^\circ$ them find $\angle COD$.

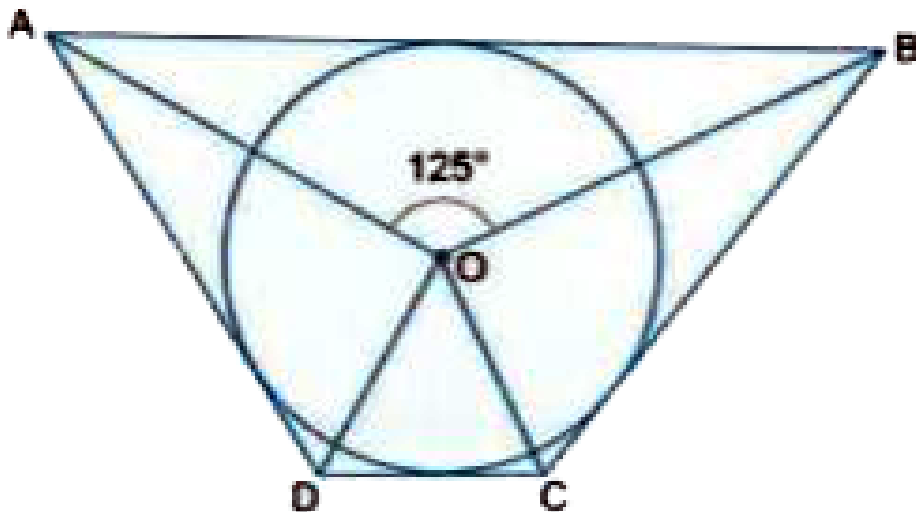

Answer: 55°

[▶ Watch Video Solution](#)

12. In Fig RQ is a chord of the circle and POQ is its diameter such that $\angle RPQ = 30^\circ$. If QT is the tangent to the circle at the point Q them find $\angle RQT$.

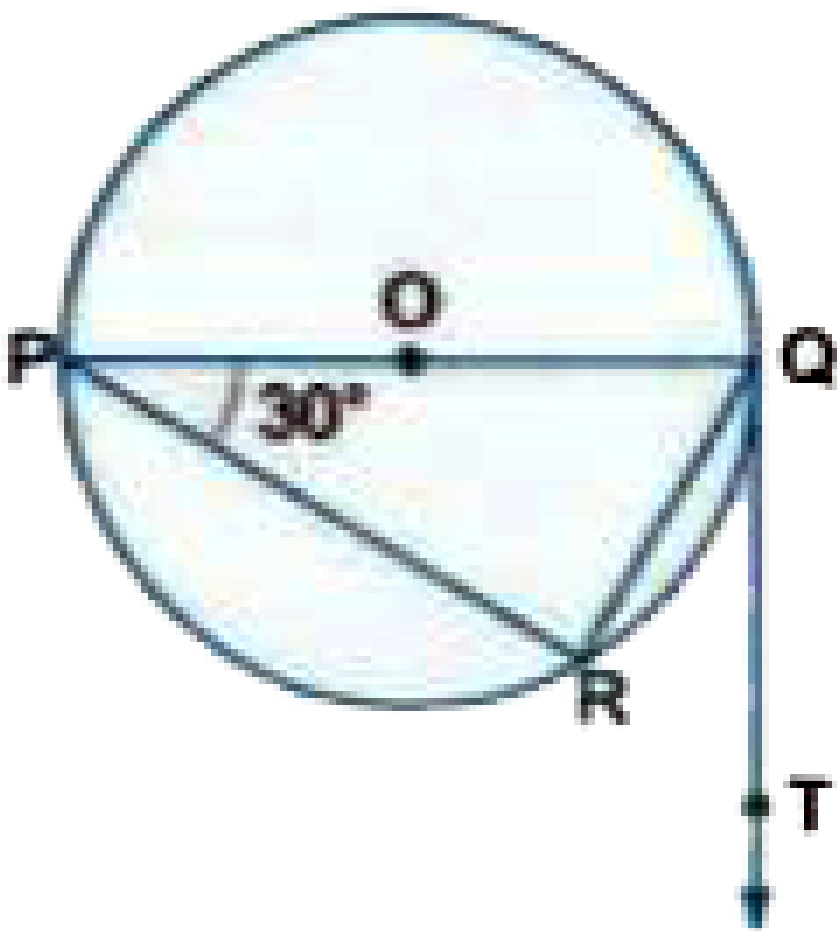

Answer: 30°

[▶ Watch Video Solution](#)

13. In Fig, AOB is diameter of a circle with centre O and AC is a tangent to the circle at A . If $\angle BOC = 130^\circ$, then find $\angle ACO$.

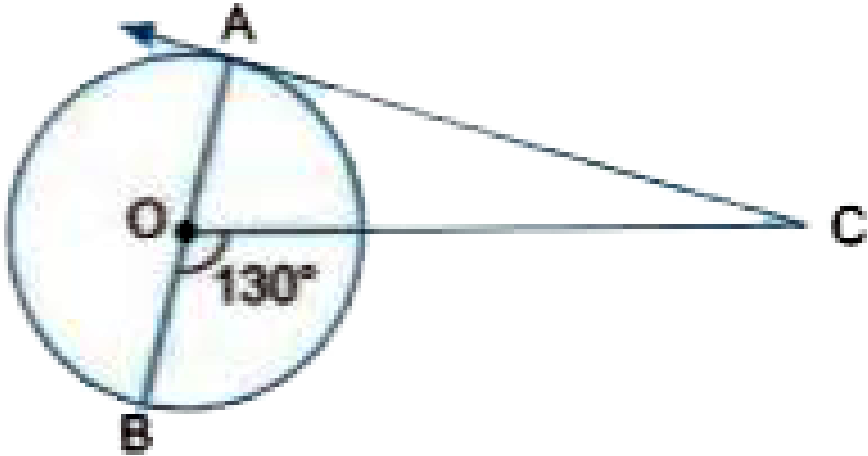

Answer: $\angle ACO = 40^\circ$

[▶ Watch Video Solution](#)

PROFICIENCY EXERCISE (Short Answer Questions - 1 2 mark)

1. In Fig. BOA is a diameter of a circle with centre O and the tangent at a point P meets BA extended at T . If

$\angle ABP = 40^\circ$ then $\angle PTA$ is equal to 40°



Answer: False $\angle PTA = 10^\circ$

[▶ Watch Video Solution](#)

2. If a number of circles touch line segment PQ at a point A then , their centres lie on the perpendicular bisector of PQ.

State True or False

Answer: False

[▶ Watch Video Solution](#)

3. If angle between two tangents drawn from a point P to a circle of radius a and centre O is 60° then $OP = a\sqrt{3}$.

Answer: False

 [Watch Video Solution](#)

4. If a chord PQ subtends an angle of 80° at the centre of a circle, then angle between the tangents at P and Q is also 80°

State true or false

Answer: False

 [Watch Video Solution](#)

5. The length of tangent from an external point on a circle is always greater than the radius of the circle.

Answer: False

 [Watch Video Solution](#)

6. In Fig. 10.76, CP and CQ are tangents from an external point C to a circle with centre O . AB is another tangent which touches the circle at R . If $CP = 11\text{cm}$ and $BR = 4\text{cm}$, find the length of BC . (FIGURE)

Answer: 7 cm

 [Watch Video Solution](#)

7. In Fig AB is the diameter of a circle O and AT is a tangent

If $\angle AOQ = 58^\circ$, find $\angle ATQ$.

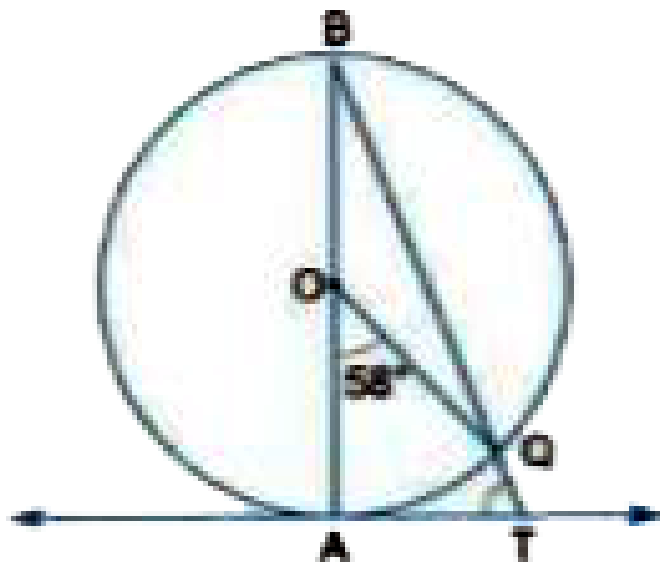

Answer: 61°

[▶ Watch Video Solution](#)

8. Find the length of the the tangent from the external point P at a distance of 20 cm from the centre of a circle of radius 12 cm.

Answer: 16 cm



[Watch Video Solution](#)

9. Two tangents AB and AC are drawn from an external point A to a circle with centre O . If they are inclined to each other at an angle of 100° then what is the value of $\angle BOC$.

Answer: 80°



[Watch Video Solution](#)

10. The length of tangent from a point A at a distance of 12 cm from the centre of the circle is 9 cm. What is the radius of the circle ?

Answer: $3\sqrt{7}$



[Watch Video Solution](#)

11. In Fig BA and BC are tangents to the circle drawn from an external point B . PQ is a tangent touching the circle at R. If BC = 12 cm and PR = 3 cm, what is the perimeter of ΔBPQ ?

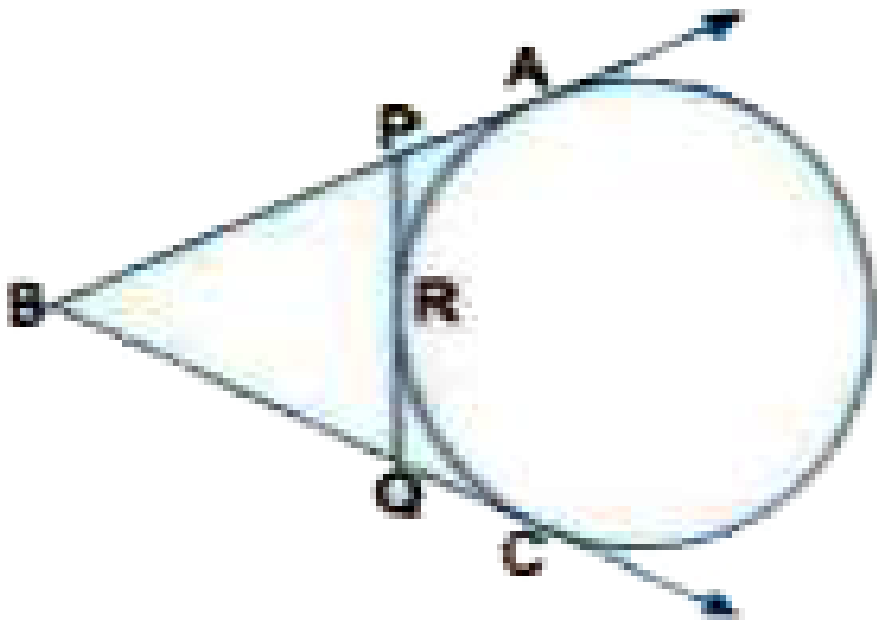

Answer: 24 cm

 [Watch Video Solution](#)

12. In the given figure two concentric circles with centre O are of radii 5 cm and 3 cm. From an external point P , tangents PA and PB are drawn to these circles. If $AP = 12$ cm find BP .

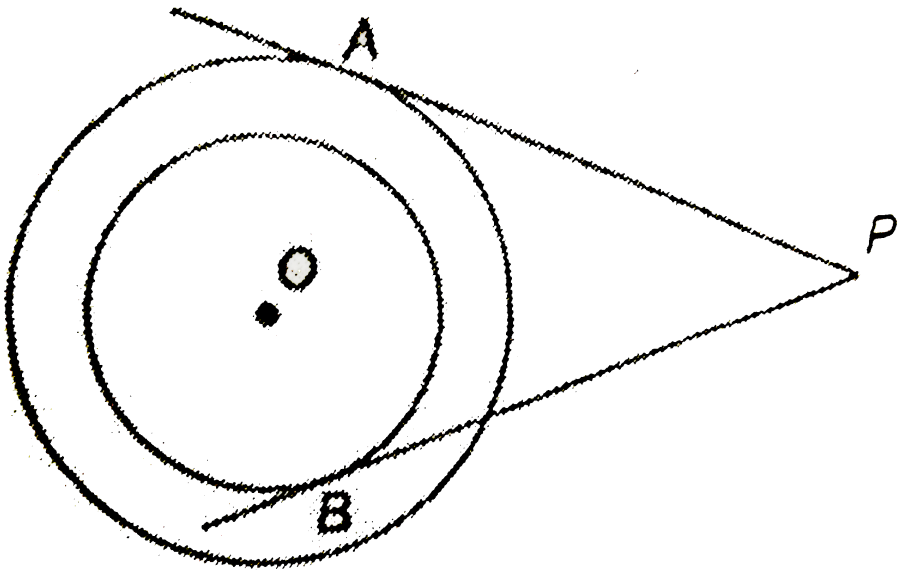

Answer: $4\sqrt{10}$ cm

 [Watch Video Solution](#)

13. From an external point P , two tangents PA and PB are drawn to the circle with centre O . Prove that OP is the perpendicular bisector of AB .

 Watch Video Solution

PROFICIENCY EXERCISE (Short Answer Questions - II 3 mark)

1. Two tangents PA and PB are drawn to a circle with centre O from an external point P . Prove that $\angle APB = 2\angle OAB$

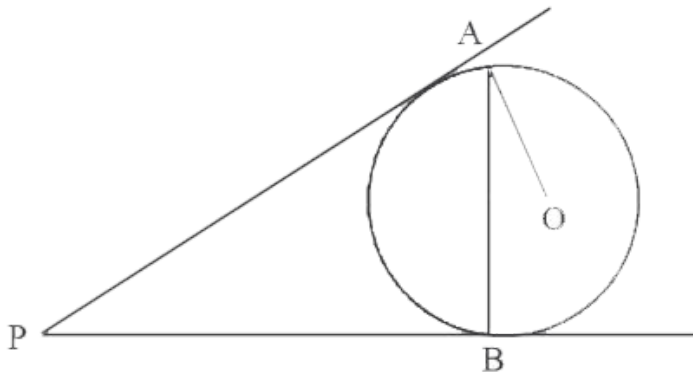



[Watch Video Solution](#)

2. Two concentric circles area of radii 8cm and 5cm. Find the length of the chord of the length circle which touches the smaller circle.

Answer: $2\sqrt{39}cm$



[Watch Video Solution](#)

3. $\triangle ABC$ is an isosceles triangle in which $AB=AC$, circumscribed about a circle. Prove that the base is bisected by the point of contact.



[Watch Video Solution](#)

4. From a point P , two tangents PA and PB are drawn to a circle with centre O . If $OP =$ diameter of the circle, show that APB is equilateral.



[Watch Video Solution](#)

5. If AB, AC, PQ are tangents in Fig. , $PX = 2\text{cm}$ and $AB = 5\text{cm}$ Find the perimeter of $\triangle APQ$

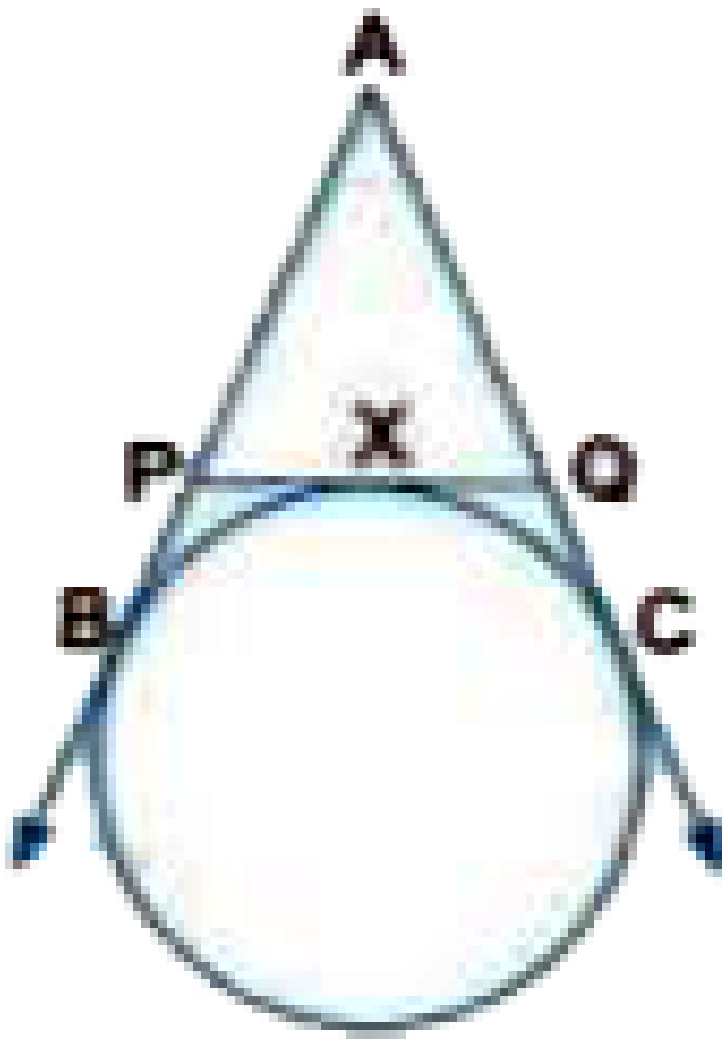

Answer: 10 cm



Watch Video Solution

6. A circle is inscribed in a $\triangle ABC$ having sides 8 cm , 10 cm and 12 cm in Fig Find AD, BE and CF.

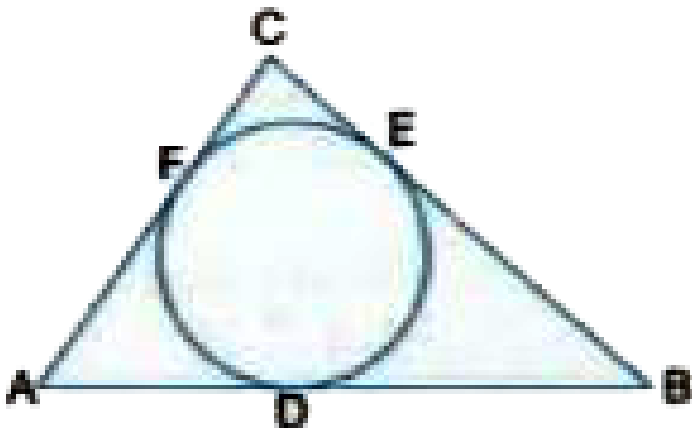

Answer: AD = 7 cm , BE = 5 cm , CF = 3 cm

[▶ Watch Video Solution](#)

7. PQ is a chord of length 8 cm of a circle of radius 5 cm. The tangents at P and Q intersect at a point T . Find the length TP .

Answer: $\frac{15}{4} \text{ cm}$

[▶ Watch Video Solution](#)

8. ABC is Right triangle, right angled at B such that BC = 6 and AB = 8 cm. Find the radius of its incircle.

Answer: 2 cm

[▶ Watch Video Solution](#)

9. In figure, AB and CD are common tangents to two circles of unequal radii. Prove that $AB=CD$

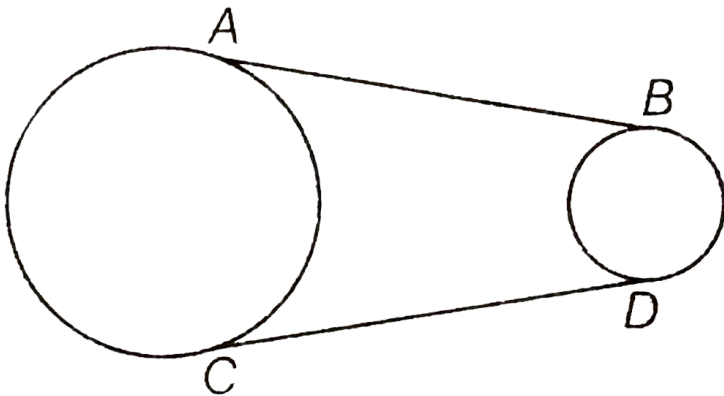

[▶ Watch Video Solution](#)

10. In figure, common tangents AB and CD to two circles intersect at E . Prove that $AB=CD$.

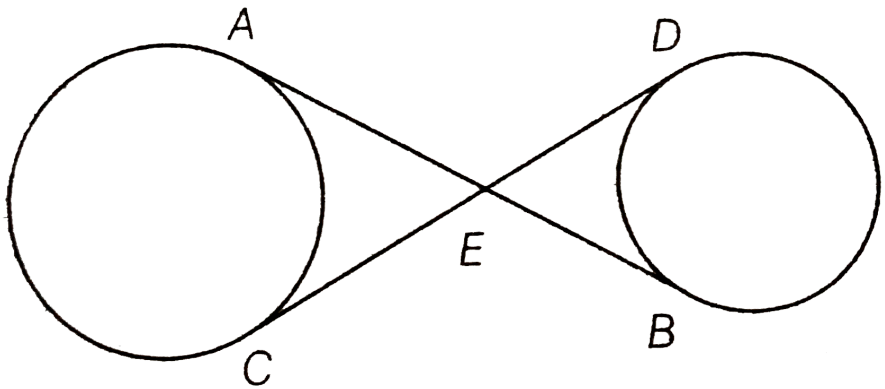

[▶ Watch Video Solution](#)

11. Two tangents PQ and PR are drawn from an external point to a circle with centre O . Prove that $QORP$ is cyclic quadrilateral.

[▶ Watch Video Solution](#)

12. In Fig. 10.54, a circle touches all the four sides of a quadrilateral $ABCD$ with $AB = 6\text{ cm}$, $BC = 7\text{ cm}$ and $CD = 4\text{ cm}$. Find AD . (FIGURE)

Answer: 3 cm

 [Watch Video Solution](#)

13. PQL and PRM are tangents to a circle with centre O at points Q and R respectively. S is a point on the circle such that $\angle SQL = 50^\circ$ and $\angle SRM = 60^\circ$. Find value of $\angle QSR$.

Answer: 70°

 [Watch Video Solution](#)

14. A chord PQ of a circle is parallel to the tangent drawn at a point R of the circle, Prove that R bisects the arc PRQ .

 [Watch Video Solution](#)

15. If from an external point P of a circle with centre O, two tangents PQ and PR are drawn such $\angle QPR = 120^\circ$, prove that $2PQ=PO$.

 [Watch Video Solution](#)

16. If Fig. 'O' is the centre of the circle Determine $\angle AQB$ and $\angle AMB$ if PA and PB are tangents and $\angle APB = 75^\circ$.

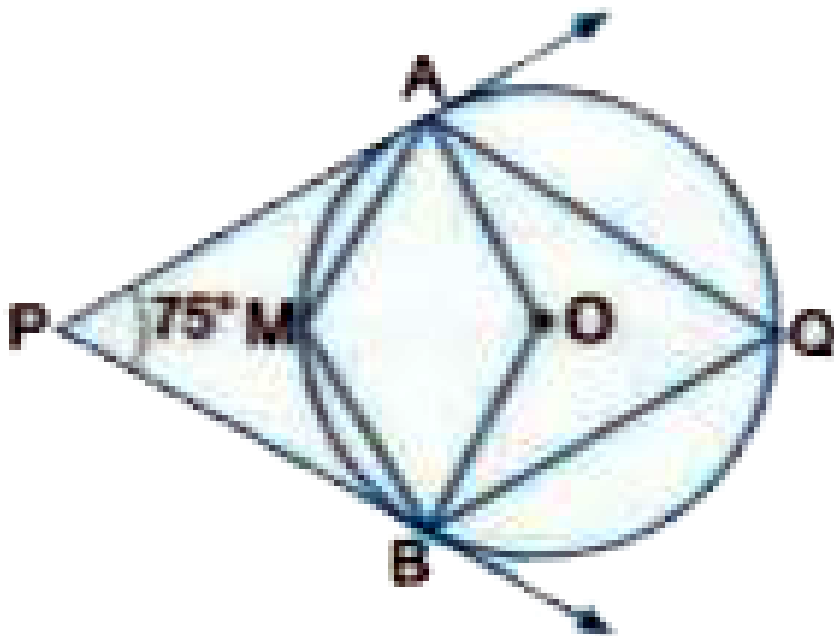

Answer: 52.5° , 127.5°

[▶ Watch Video Solution](#)

17. From a point P, two tangents PA and PB are drawn to a circle with centre O and radius r. If $OP=2r$, show that

$\triangle APB$ is equilateral.

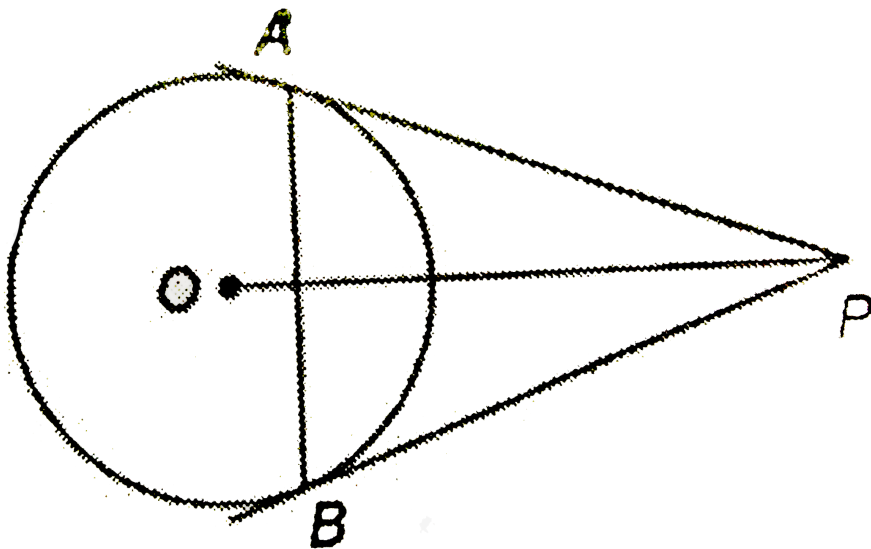

Watch Video Solution

18. Find the actual length of sides of $\triangle OTP$ (Fig)

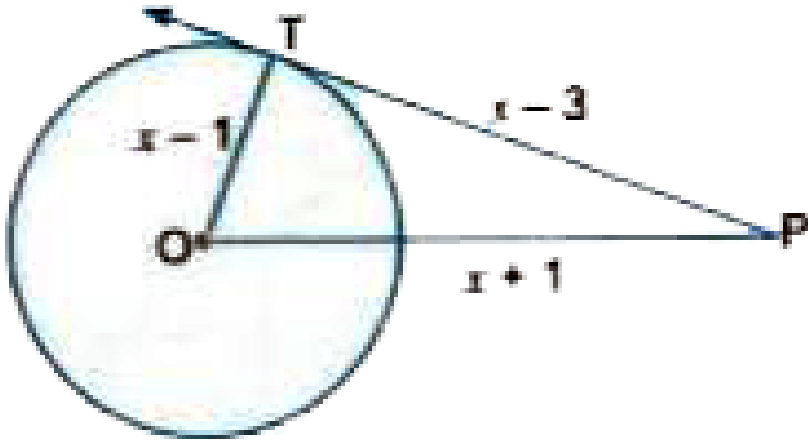

Answer: 6 cm , 8 cm , 10 cm

[▶ Watch Video Solution](#)

19. Find the perimeter of $\triangle DEF$. (Fig.) .

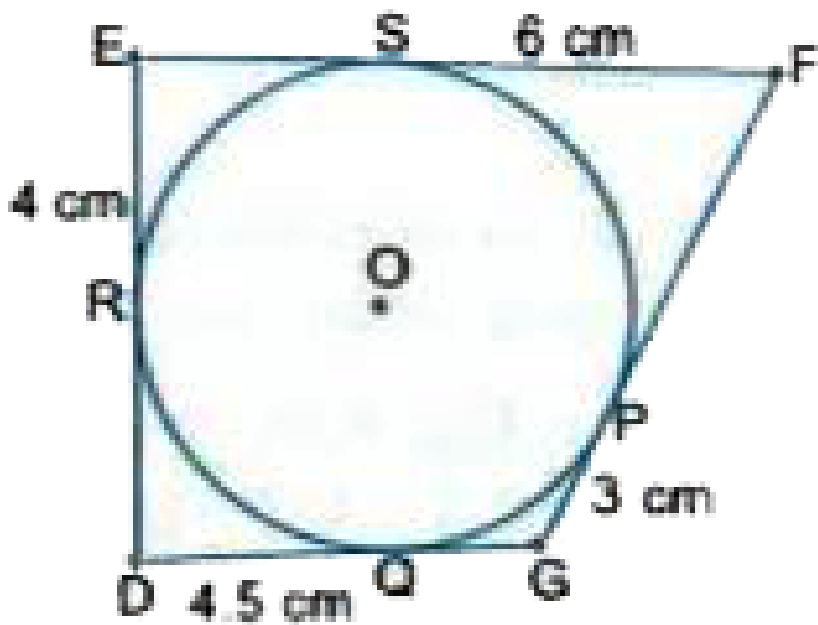

Answer: 35 cm

[▶ Watch Video Solution](#)

20. If d_1, d_2 ($d_2 > d_1$) be the diameters of two concentric circles and c be the length of a chord of a circle which is

tangent to the other circle prove that $d_2^2 = c^2 + d_1^2$



[Watch Video Solution](#)

21. In Fig. 10.57, a circle is inscribed in a quadrilateral $ABCD$ in which $\angle B = 90^\circ$. If $AD = 23\text{cm}$, $AB = 29\text{cm}$ and $DS = 5\text{cm}$, find the radius r of the circle. (FIGURE)

Answer: 11 cm



[Watch Video Solution](#)

22. Let s denotes the semi-perimeter of a $\triangle ABC$ in which $BC=a$, $CA=b$ and $AB=c$. If a circle touches the sides BC , CA , AB , at D , E , F , respectively. Prove that $BD=s-b$.





Watch Video Solution

PROFICIENCY EXERCISE (Long Answer Questions 4 mark)

1. In figure, tangents PQ and PR are drawn to a circle such that $\angle RPQ = 30^\circ$. A chord RS is drawn parallel to the tangent PQ. Find the $\angle RQS$.

Answer: 30°



Watch Video Solution

2. Two circles with centres O and O' of radii 3 cm and 4 cm, respectively intersect at two points P and Q such that OP and O'P are tangents to the two circle. Find the length of

the common chord PQ.

Answer: 4.8 cm



Watch Video Solution

3. If a hexagon ABCDEF circumscribe a circle, prove that

$$AB + CD + EF = BC + DE + FA$$



Watch Video Solution

4. In a right angle triangle $\triangle ABC$ in which $\angle B = 90^\circ$ a

circle is drawn with AB diameter intersecting the

hypotenuse AC at P. Prove that the tangent to the circle at

PQ bisects BC.



Watch Video Solution

5. A is a point at a distance 10 cm from the centre O of a circle of radius 6cm . AP and AQ are the tangents to the circle at P and Q .If a tangent BC is drawn at a point R lying on the minor arc PQ to intersect AP at B and AQ at C, find the perimeter of the $\triangle ABC$.

Answer: 16 cm



Watch Video Solution

6. In a figure the common tangents, AB and CD to two circles with centers O and O' intersect at E. Prove that the

points O , E and O' are collinear.

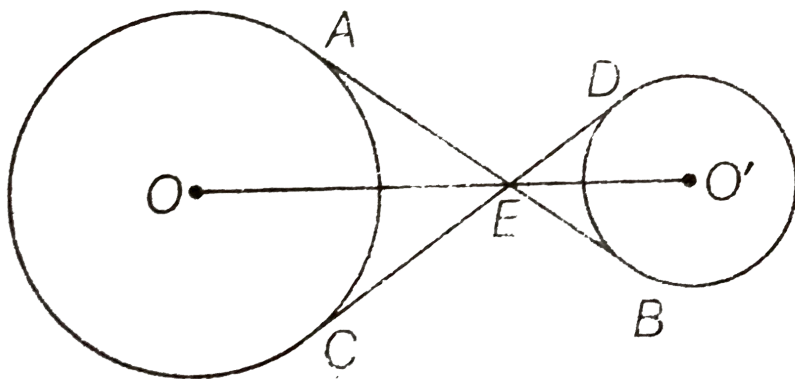

[▶ Watch Video Solution](#)

7. If an isosceles triangle ABC in which $AB = AC = 6\text{cm}$ is inscribed in a circle of radius 9cm , find the area of the triangle.

Answer: $8\sqrt{2}\text{cm}^2$

[▶ Watch Video Solution](#)

8. The tangent at a point C of a circle and a diameter AB when extended intersect at P . If $\angle PCA = 110^\circ$ find $\angle CBA$.

Answer: 50°

 [Watch Video Solution](#)

9. O is the centre of a circle of radius 5cm . T is a point such that $OT = 13\text{cm}$ and OT intersects the circle at E . If AB is the tangent to the circle at E , find length of AB .

Answer: $\frac{20}{3}\text{cm}$

 [Watch Video Solution](#)

10. If an isosceles triangle ABC , in which $AB = AC = 10$ cm , is inscribed in a circle of radius 10 cm , find the area of the triangle .

Answer: $25\sqrt{3}cm^2$



Watch Video Solution

11. In the given figure, O is the centre of the circle and TP is the tangent to the circle from an external point T . If $\angle PBT = 30^\circ$, prove that $BA:AT = 2:1$



Watch Video Solution

12. In Fig , AB is a chord of a circle , with centre O , such that $AB = 16$ cm and radius of circle is 10 cm. Tangents at

A and B intersect each other at P . Find the length of PA.

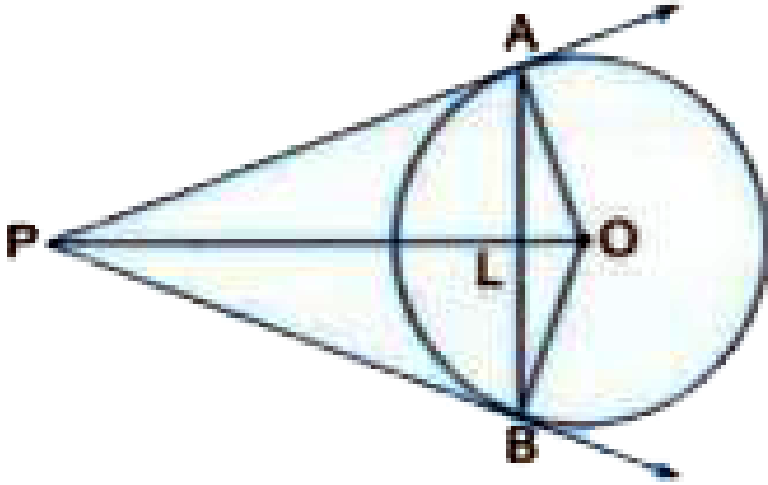

Answer: $\frac{40}{3} \text{ cm}$

[▶ Watch Video Solution](#)

SELF - ASSESSMENT TEST

1. In Fig . pair of tangents AP and AQ drawn from an external point A to a circle with centre O are perpendicular to each other and length of each tangent is 5 cm. Find the

radius of the circle.

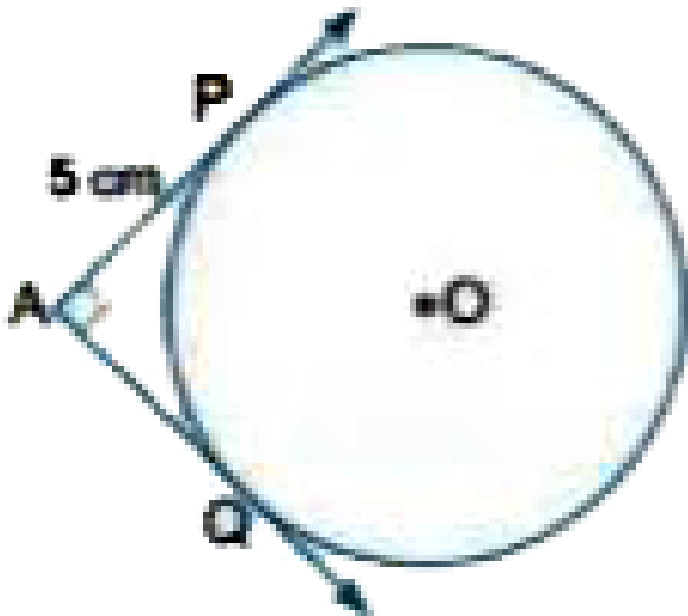

Answer: 5 cm

[▶ Watch Video Solution](#)

2. AB and CD are common tangents to two circles which intersect each other at C as shown in the figure IF $AB = 6\text{cm}$, find CD.

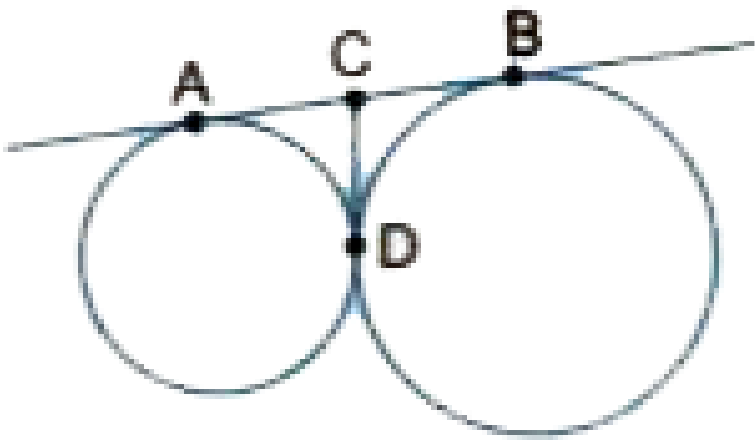

Answer: 3 cm

[▶ Watch Video Solution](#)

3. In Fig PT is a tangent to the circle (O,r) such that $OT = 6\sqrt{3}$ units and $\angle OTP = 30^\circ$ Find the length of PT.

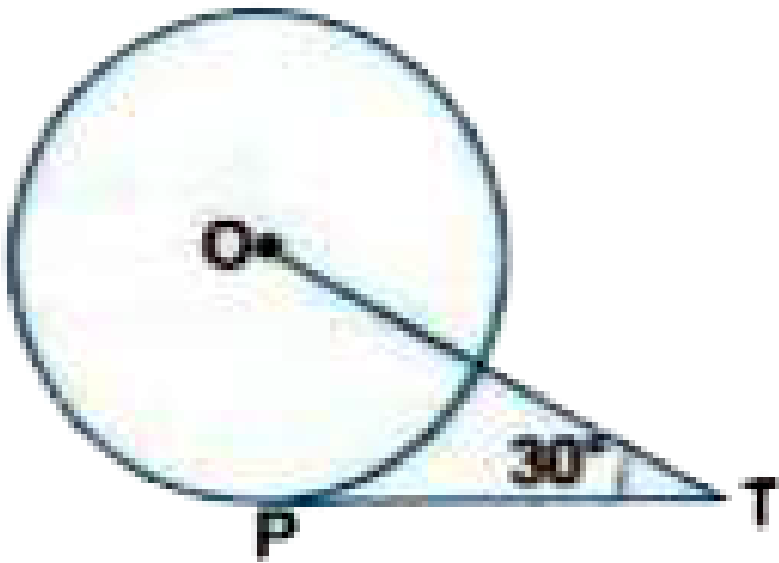

Answer: 9 units

[▶ Watch Video Solution](#)

4. In Fig O is the centre of a circle and AT is a tangent at point A . what is the measure of $\angle BAT$?

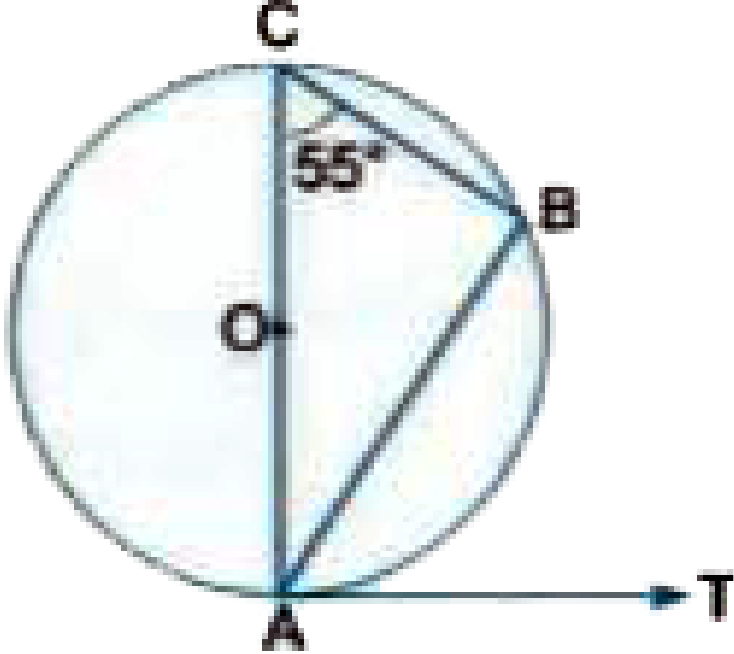

Answer: 55°

[▶ Watch Video Solution](#)

5. In the Fig Prove that $XA+AR=XB+BR$.

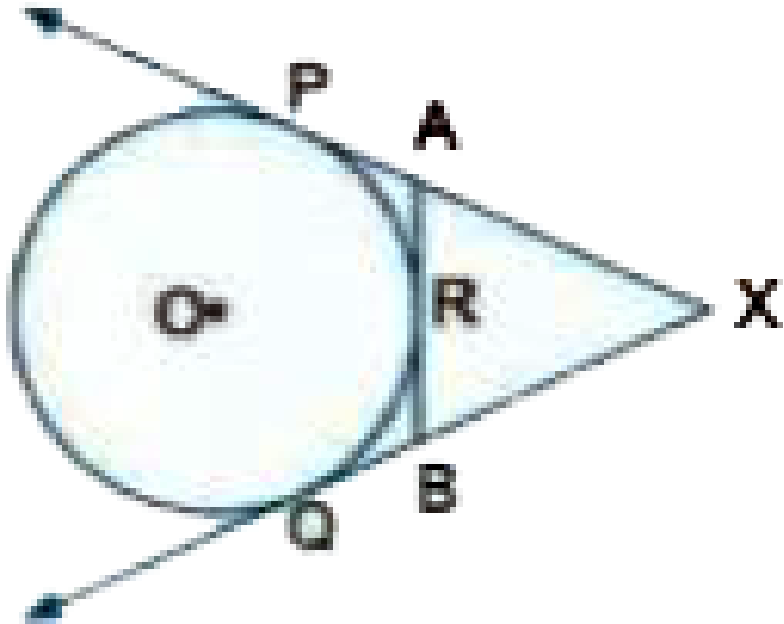

[▶ Watch Video Solution](#)

6. In Fig. two tangents RQ and RP are drawn from an external point R to the circle with centre O. If

$\angle PRQ = 120^\circ$, then prove that $OR = PR + RQ$.

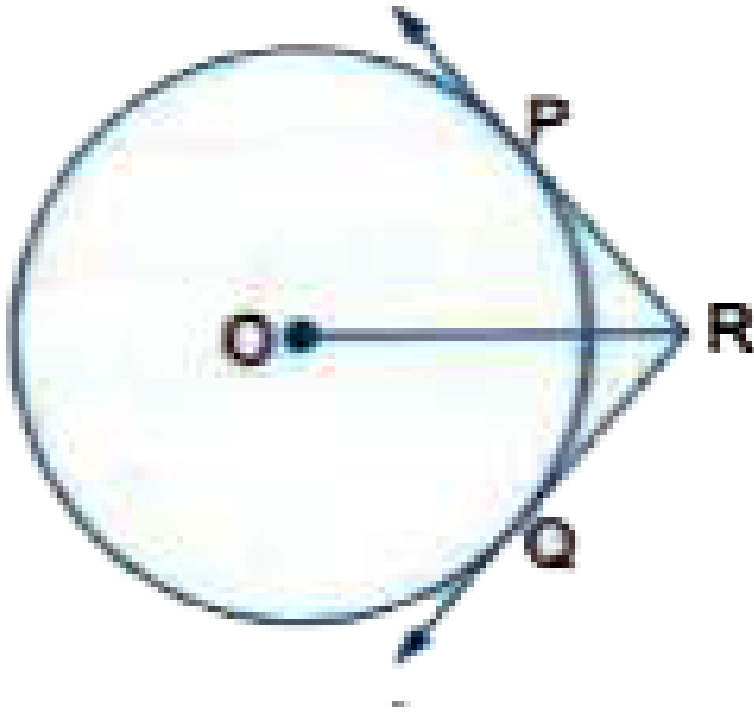

[▶ Watch Video Solution](#)

7. Out of the 2 concentric circle the radius of the outer circle is 5 cm and the chord AC of the length 8 cm is a tangent to the inner circle find the radius of the inner circle

Answer: 3 cm

 [Watch Video Solution](#)

8. Two circles touch each other externally. Prove that the lengths of the tangent drawn to the two circles from any point on the common tangent lie at the point of contact of two circles are equal .

 [Watch Video Solution](#)

9. P & Q are centres of circles of radii 9 cm and 2cm respectively. $PQ = 17$ cm. R is the centre of the circle of radius x cm which touches the above externally. Given that angle, $\angle PRQ$ is 90° . Write an equation in x and solve it.

Answer: $x^2 + 11x - 102 = 0, x = 6\text{cm}$

 [Watch Video Solution](#)

10. A circle is inscribed in a $\triangle ABC$ having sides 8 cm, 10 cm and 12 cm as shown in figure. Find AD, BE and CF.

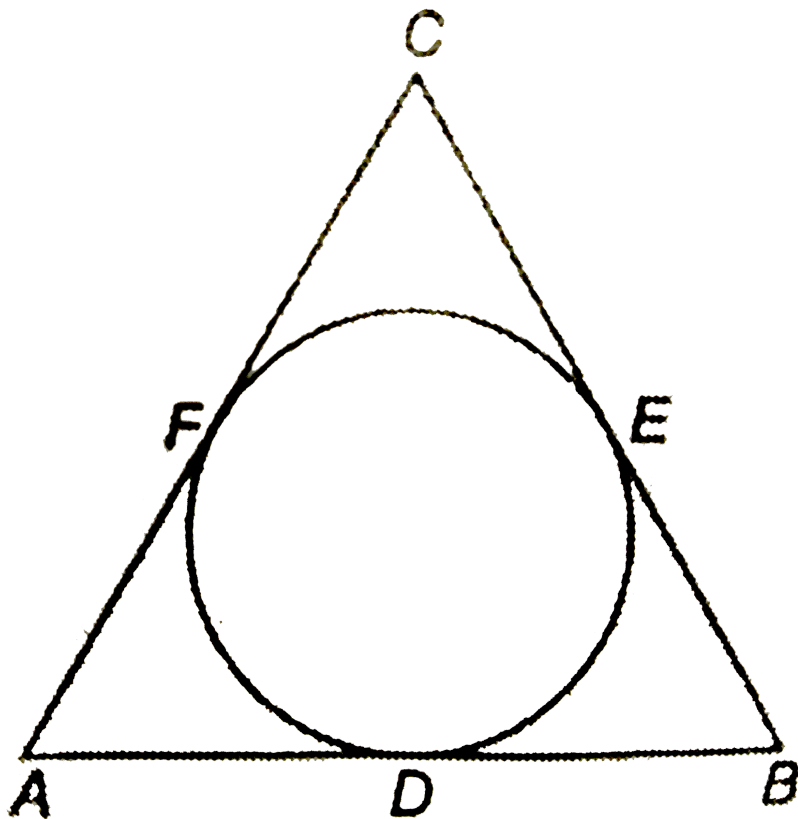

Answer: AD = 7 cm , BE = 5 cm , CF = 3 cm

[Watch Video Solution](#)

11. In Fig XY and $X'Y'$ are two parallel tangents to a circle with centre O and another tangent AB with point of contact C intersecting XY and $X'Y'$ at B , prove that $\angle AOB = 90^\circ$

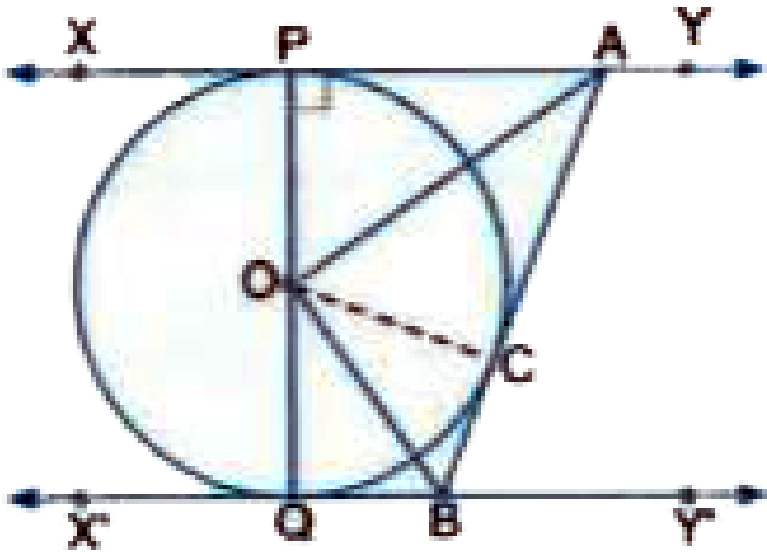

[▶ Watch Video Solution](#)