



PHYSICS

BOOKS - AIIMS PREVIOUS YEAR PAPERS

AIIMS 2019 26 MAY MORNING SHIFT

Physics

1. If energy of electron in ground state is -13.6 then find out speed of electron in fourth orbit of H-atom

A. $5.45 \times 10^6 m/s$

B. $5.45 \times 10^5 m/s$

C. $5.45 \times 10^4 m/s$

D. $4.45 \times 10^5 m/s$

Answer: B



[Watch Video Solution](#)

2. In a LCR oscillatory circuit find the energy stored in inductor at resonance. If voltage of source is 10 V and resistance is 10Ω and inductance = 1H.

A. 0.5 J

B. 2 J

C. 4 J

D. 10 J

Answer: A



[Watch Video Solution](#)

3. 15 eV is given to e^- in 4th orbit then find it's final energy when it comes out of H-atom

A. 14.14 eV

B. 13.6 eV

C. 12.08 eV

D. 15.85

Answer: A



Watch Video Solution

4. For a toroid $N = 500$, radius = 40 cm, and area of cross section = 10cm^2 . Find inductance

A. $125\mu\text{H}$

B. $250\mu\text{H}$

C. 0.00248 H

D. zero

Answer: A

 [Watch Video Solution](#)

5. Calculate the binding energy per nucleon (B.E./nucleon) in the nuclei of

${}_{26}\text{Fe}^{56}$. Given :

$$m_p[{}_{26}\text{Fe}^{56}] = 55.934939 \text{ amu}, m[{}_{0}n^1] = 1.00865 \text{ amu}, m[{}_{1}\text{H}^1] = 1.007825 \text{ amu}$$

A. 477.45 MeV

B. 8.52 MeV

C. 577 MeV

D. 10.52 MeV

Answer: B

 [Watch Video Solution](#)

6. A string wave equation is given $y = 0.002 \sin(300t - 15x)$ and mass density is $\left(\mu = \frac{0.1\text{kg}}{m}\right)$. Then find the tension in the string

A. 30 N

B. 20 N

C. 40 N

D. 45 N

Answer: C

 [Watch Video Solution](#)

7. If maximum energy is stored in capacitor at $t = 0$ then find the time after which current in the circuit will be maximum.

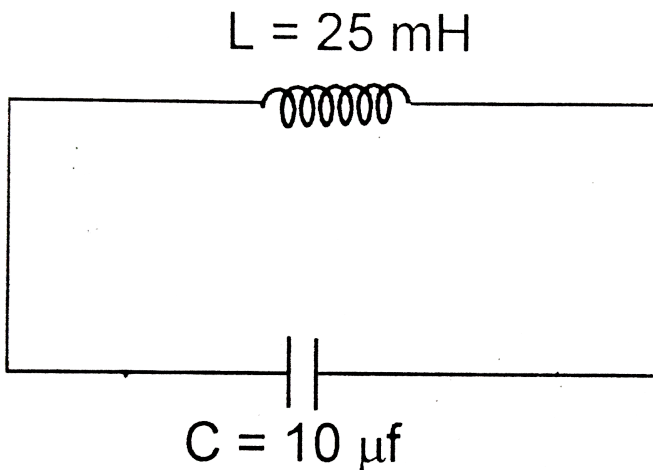

A. $\frac{\pi}{2}ms$

B. $\frac{\pi}{4}ms$

C. πms

D. $2ms$

Answer: B

 Watch Video Solution

8. When capacitor is fully charged, find current drawn from the cell.

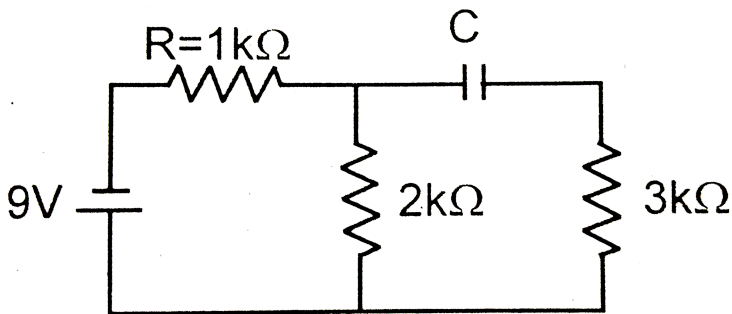

A. 2mA

B. 1 mA

C. 3 mA

D. 9 mA

Answer: C

 Watch Video Solution

9. Given $V_{CM} = 2\frac{m}{s}$, $m = 2kg$, $R = 4m$

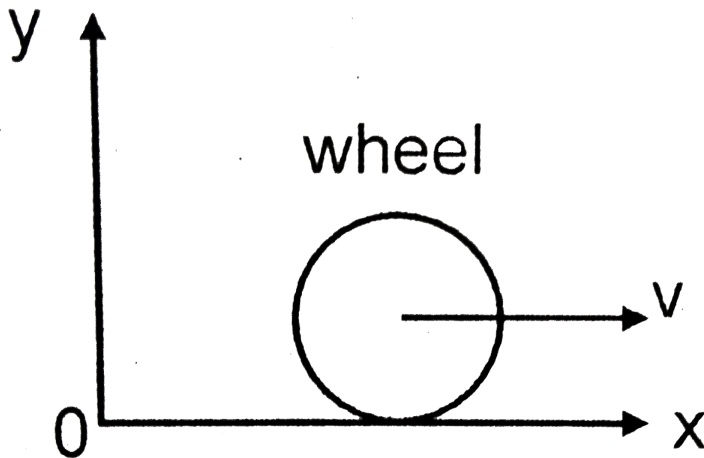

Find angular momentum of ring about origin if it is in pure rolling

A. $32kgm^2/s$

B. $24kgm^2/s$

C. $16kgm^2 / s$

D. $8kgm^2 / s$

Answer: A

[▶ Watch Video Solution](#)

10. If voltage across zener diode is 6V then find out value of maximum resistance in this condition.

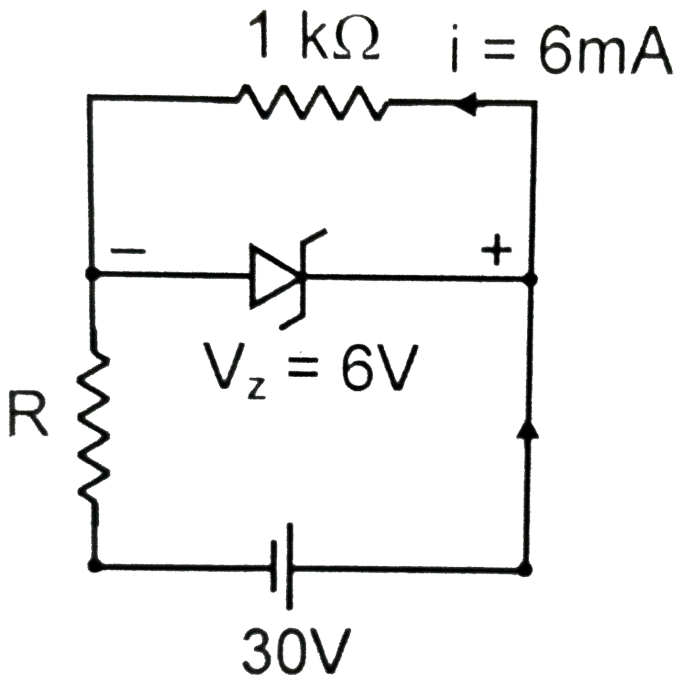

A. $2k\Omega$

B. $3k\Omega$

C. $5k\Omega$

D. $4k\Omega$

Answer: D



Watch Video Solution

11. A transformer consists of 500 turn in primary coil and 10 turns in secondary coil with the load of 10Ω . Find out current in the primary coil when the voltage across secondary coil is 50 V.

A. 5A

B. .1A

C. 10A

D. 2A

Answer: B

[Watch Video Solution](#)

12. Find force per unit length at P

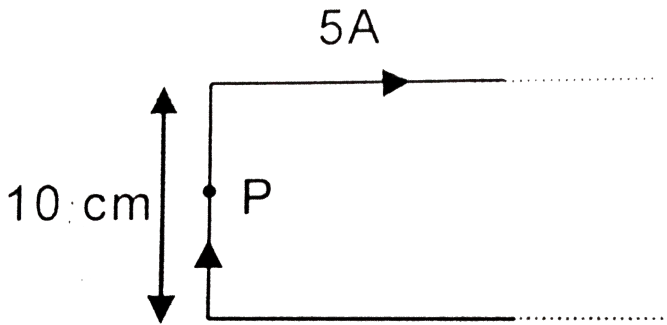

A. $10^{-4}m$

B. $10^{-4}N/m$

C. $3 \times 10^{-4}N/m$

D. $0.3N/m$

Answer: B

[Watch Video Solution](#)

13. Find magnetic field at centre P if length of side of square loop is 20 cm.

3Amp

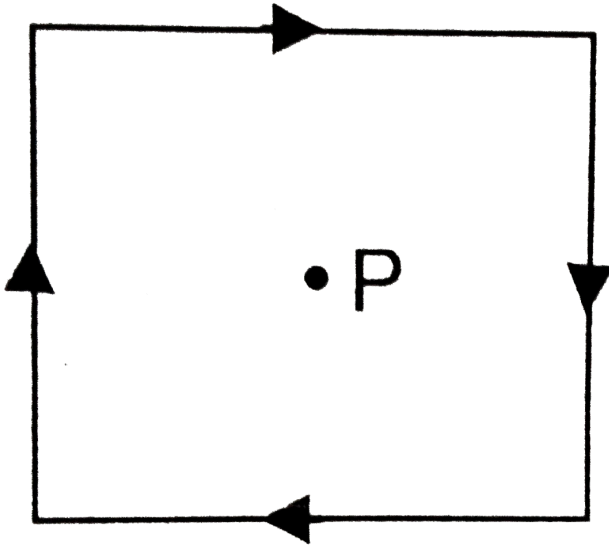

A. $12\sqrt{2} \times 10^{-6} T$

B. $12 \times 10^{-6} T$

C. $6 \times 10^{-6} T$

D. $6\sqrt{2} \times 10^{-6} T$

Answer: A



Watch Video Solution

14. What is the dimension of Luminous flux :

A. $[cd^1]$

B. $[cd^1T^{-1}]$

C. $[cd^1L^{-2}]$

D. $[cd^1L^1T^{-1}]$

Answer: A



Watch Video Solution

15. Two circular loops having same radius [$R = 10 \text{ cm}$] and same current

$\frac{7}{2}A$ are placed along same axis as shown. If distance between their

centre is 10 cm. find net magnetic field at of point P.

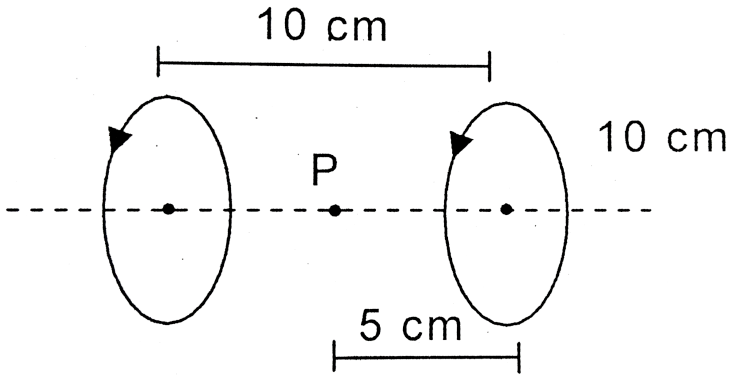

- A. $\frac{50\mu_0}{\sqrt{5}}T$
- B. $\frac{28\mu_0}{\sqrt{5}}T$
- C. $\frac{56\mu_0}{\sqrt{5}}T$
- D. $\frac{56\mu_0}{\sqrt{3}}T$

Answer: C

[Watch Video Solution](#)

16. If half life of an element is 69.3 hours then how much of its percent will decay in 10^{th} to 11^{th} hours.

Initial activity = $50\mu Ci$

A. 1 %

B. 2 %

C. 3 %

D. 4 %

Answer: A



[Watch Video Solution](#)

17. Initially spring in its natural length now a block at mass 0.25 kg is released then find out maximum force by system on floor ?

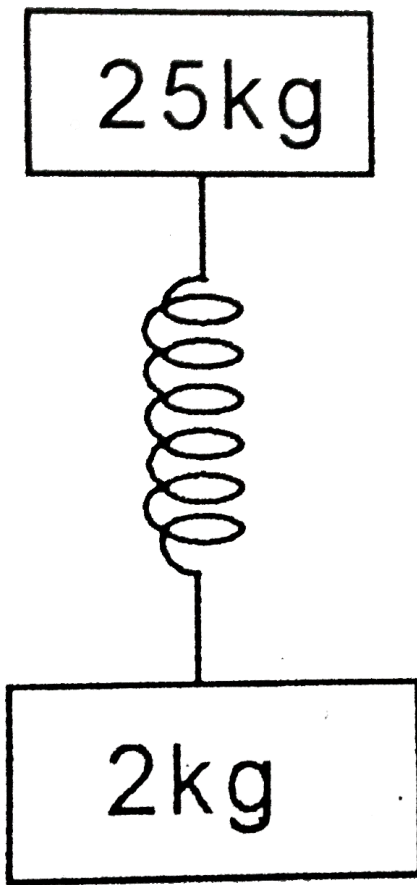

- A. 15 N
- B. 20 N
- C. 25 N
- D. 30 N

Answer: C

 Watch Video Solution

18. If 7 gm N_2 is mixed with 20 gm Ar, there C_p/C_v of mixture will be :

A. $\frac{17}{6}$

B. $\frac{11}{7}$

C. $\frac{17}{11}$

D. $\frac{17}{13}$

Answer: C

 Watch Video Solution

19. If $f_0 = 5c$, $\lambda 6000\text{\AA}$, $a = 1\text{cm}$ for a microscope, then wht will be its resolving power

A. $11.9 \times 10^5 / m$

B. $10.9 \times 10^5 / m$

C. $10.9 \times 10^4 / m$

D. $10.9 \times 10^3 / m$

Answer: B



[Watch Video Solution](#)

20. Distance of 5th dark fringe from centre is 4 mm. If $D = 2 \text{ m}$, $\lambda = 600 \text{ nm}$, then distance between slits is :

A. 1.35 mm

B. 2.00 mm

C. 3.25 mm

D. 10.35 mm

Answer: A



[Watch Video Solution](#)

21. A conducting and closed container of capacity 100 liter contains an ideal gas at a high pressure. Now using a pump, the gas is taken out at a constant rate of 5 liter/sec. Find the time taken in which the pressure will decrease to initial $\frac{P_{\text{initial}}}{100}$? (Assume isothermal condition)

- A. 46 sec
- B. 92 sec
- C. 118 sec
- D. 146 sec

Answer: B

 [View Text Solution](#)

22. How can we change a camera from F/4 to F/5.6?

- A. Increase the aperture to 2 time keeping the focal distance constant.

B. Increase the aperture to $\sqrt{2}$ time keeping the focal distance constant.

C. Increase the aperture to $\frac{1}{2}$ time keeping the focal distance constant.

D. Increase the aperture to $\frac{1}{\sqrt{2}}$ time keeping the focal distance constant

Answer: D



[Watch Video Solution](#)

23. Force on current carrying loop (Radius = R) in uniform magnetic (B) field which is at an angle 30° with the normal will be :-

A. zero

B. $2\pi RiB$

C. $2\sqrt{3}\pi RiB$

D. πRiB

Answer: A



[View Text Solution](#)

24. Assertion : Sometimes insects can walk on water.

Reason : The gravitational force on insect is balanced by force due surface tension.

- A. If both assertion and reason are true and reason is the correct explanation of assertion.
- B. If both assertion and reason are true but reason is not the correct explanation of assertion.
- C. If assertion is true but reason is false.
- D. If both assertion and reason are false.

Answer: A



[Watch Video Solution](#)

25. Assertion: Incoming light reflected by earth is partially polarized.

Reason: Atmospheric particle polarize the light.

- A. If both assertion and reason are true and reason is the correct explanation of assertion.
- B. If both assertion and reason are true but reason is not the correct explanation of assertion.
- C. If assertion is true but reason is false.
- D. If both assertion and reason are false.

Answer: A



[Watch Video Solution](#)

26. Assertion : Photodiode and solar cell work on same mechanism.

Reason : Area is large for solar cell.

- A. If both assertion and reason are true and reason is the correct explanation of assertion.
- B. If both assertion and reason are true but reason is not the correct explanation of assertion.
- C. If assertion is true but reason is false.
- D. If both assertion and reason are false.

Answer: B



[Watch Video Solution](#)

27. Assertion : 3_1H isotope does not undergo fusion of the type ${}^3_1H + {}^2_1H \rightarrow$ as it is rarely found in nature.
- Reason : 3_1H has half life of ≈ 12 years.

- A. If both assertion and reason are true and reason is the correct explanation of assertion.

B. If both assertion and reason are true but reason is not the correct explanation of assertion.

C. If assertion is true but reason is false.

D. If both assertion and reason are false.

Answer: B

 [View Text Solution](#)

28. Assertion : Macro properties of gas are affected with increase in height.

Reason : These properties of gases depend on thermodynamic parameters.

A. If both assertion and reason are true and reason is the correct explanation of assertion.

B. If both assertion and reason are true but reason is not the correct explanation of assertion.

C. If assertion is true but reason is false.

D. If both assertion and reason are false.

Answer: D



View Text Solution

29. Assertion : V_{rms} and V_{mean} of gaseous molecules is nearly of the order of velocity of sound.

Reason : The sound travels in air because of vibrational molecular motion.

A. If both assertion and reason are true and reason is the correct explanation of assertion.

B. If both assertion and reason are true but reason is not the correct explanation of assertion.

C. If assertion is true but reason is false.

D. If both assertion and reason are false.

Answer: B



[View Text Solution](#)

30. Assertion : The kinetic energy does not change when a particle moves in uniform magnetic field.

Reason : The velocity of the particle is not affected by magnetic field.

- A. If both assertion and reason are true and reason is the correct explanation of assertion.
- B. If both assertion and reason are true but reason is not the correct explanation of assertion.
- C. If assertion is true but reason is false.
- D. If both assertion and reason are false.

Answer: A



[Watch Video Solution](#)

31. Assertion : For revolving electron, direction of angular momentum and magnetic moment are opposite.

Reason : Charge of electron is negative.

- A. If both assertion and reason are true and reason is the correct explanation of assertion.
- B. If both assertion and reason are true but reason is not the correct explanation of assertion.
- C. If assertion is true but reason is false.
- D. If both assertion and reason are false.

Answer: A



[Watch Video Solution](#)

32. Assertion : A metallic surface is moved in and out in magnetic field then emf is induced in it.

Reason : Eddy current will be produced in a metallic surface moving in and out of magnetic field.

- A. If both assertion and reason are true and reason is the correct explanation of assertion.
- B. If both assertion and reason are true but reason is not the correct explanation of assertion.
- C. If assertion is true but reason is false.
- D. If both assertion and reason are false.

Answer: A



[Watch Video Solution](#)