



# MATHS

## BOOKS - NCERT EXEMPLAR MATHS (HINGLISH)

### AREAS RELATED TO CIRCLE

#### Areas Related To Circle

1. If the sum of the areas of two circles with radii  $R_1$  and  $R_2$  is equal to the area of a circle

of radius  $R$ , then

A.  $R_1 + R_2 = R$

B.  $R_1^2 + R_2^2 = R^2$

C.  $R_1 + R_2 < R$

D.  $R_1^2 + R_2^2 < R^2$

**Answer: B**



**Watch Video Solution**

2. If the sum of the circumferences of two circles with radii  $R_1$  and  $R_2$  is equal to the circumference of a circle of radius  $R$ , then

A.  $R_1 + R_2 = R$

B.  $R_1 + R_2 > R$

C.  $R_1 + R_2 < R$

D. Nothing definite can be said about the relation among  $R_1$ ,  $R_2$  and  $R$ .

**Answer: A**





3. If the circumference of a circle and the perimeter of a square are equal, then

A. Area of the circle = Area of the square

B. Area of the circle  $>$  Area of the square

C. Area of the circle  $<$  Area of the square

D. Nothing definite can be said about the

between the areas of the circle and

square

**Answer: B**



**Watch Video Solution**

4. What is the area of the largest triangle that can be inscribed in a semicircle of radius  $r$  unit.

A.  $r^2$  sq units

B.  $\frac{1}{2}r^2$  sq units

C.  $2r^2$  sq units

D.  $\sqrt{2}r^2$  sq units

**Answer: A**



**Watch Video Solution**

5. If the perimeter of a circle is equal to that of a square, then the ratio of their areas is

A. 22 : 7

B. 14 : 11

C. 7 : 22

D. 11 : 14

**Answer: B**



**Watch Video Solution**

6. It is proposed to build a single circular park equal in area to the sum of areas of two circular parks of diameters 16 m and 12 m in a locality. The radius of the new park would be

A. 10 m

B. 15 m

C. 20 m

D. 24 m

**Answer: A**



**Watch Video Solution**

7. The area of the circle that can be inscribed in a square of side 6 cm is

A.  $36\pi cm^2$

B.  $18\pi cm^2$

C.  $12\pi cm^2$



D.  $9\pi cm^2$

**Answer: D**



**Watch Video Solution**

**8.** The area of the square that can be inscribed in a circle of radius 8 cm is

A.  $256 cm^2$

B.  $128 cm^2$

C.  $\sqrt{2}r^2$

D.  $64 \text{ cm}^2$

**Answer: B**



**Watch Video Solution**

9. The radius of a circle whose circumference is equal to the sum of the circumferences of the two circles of diameters  $36\text{cm}$  and  $20\text{cm}$  is

A.  $56 \text{ cm}$

B.  $42 \text{ cm}$

C. 28 cm

D. 16 cm

**Answer: C**



**Watch Video Solution**

**10.** The diameter of a circle whose area is equal to the sum of the areas of the two circles of radii 24 cm and 7 cm is

A. 31 cm

B. 25 cm

C. 62 cm

D. 50 cm

**Answer: D**



**Watch Video Solution**

**11.** Is the area of the circle inscribed in a square of side  $a$  cm,  $\pi a^2 \text{ cm}^2$  ? Give reasons for your answer.



**Watch Video Solution**

**12.** Will it be true to say that the perimeter of a square circumscribing a circle of radius  $a$  cm is  $8a$  cm ? Give reason for your answer.



**Watch Video Solution**

**13.** In figure, a square is inscribed in a circle of diameter  $d$  and another square is circumscribing the circle . Is the area of the outer square four times the area of the inner

square ? Give reason for your answer.



**Watch Video Solution**

**14.** Is it true to say that area of segment of a circle is less than the area of its corresponding sector? Why ?



**Watch Video Solution**

15. Is it true that the distance travelled by a circular wheel of diameter  $d$  cm in one revolution is  $2\pi d$  cm ? Why ?



[Watch Video Solution](#)

16. In covering a distance  $s$  m, a circular wheel of radius  $r$  m makes  $\frac{s}{2\pi r}$  revolution. Is this statement true ? Why ?



[Watch Video Solution](#)

**17.** The numerical value of the area of a circle is greater than the numerical value of its circumference. Is this statement true? Why?



**Watch Video Solution**

**18.** If the length of an arc of a circle of radius  $r$  is equal to that of an arc of a circle of radius  $2r$ , then the angle of the corresponding of the other circle. Is this statement false? Why?



**Watch Video Solution**



**19.** The area of two sectors of two sectors of two different circles with equal corresponding arc lengths are equal. Is this statement true ?

Why ?



**Watch Video Solution**

**20.** The areas of two sectors of two different circles are equal. Is it necessary that their corresponding arc lengths are equal ? Why ?



**Watch Video Solution**

21. Is the area of the largest circle that can be drawn inside a rectangle of length  $a$  cm and breadth  $b$  cm ( $a > b$ ) is  $\pi b^2$  cm<sup>2</sup>? Why?



[Watch Video Solution](#)

22. Circumference of two circles are equal. Is it necessary that their areas be equal? Why?



[Watch Video Solution](#)

23. Areas of two circles are equal. Is it necessary that their circumferences are equal ? Why ?



[Watch Video Solution](#)

24. Is it true to say that area of square inscribed in a circle of diameter  $p$  cm is  $p^2 \text{ cm}^2$  ? Why ?



[Watch Video Solution](#)

**25.** Find the radius of a circle whose circumference is equal to the sum of the circumference of two circles of radii 15 cm and 18 cm .



**Watch Video Solution**

**26.** In figure, a square of diagonal 8 cm is inscribed in a circle. Find the area of the

shaded region.

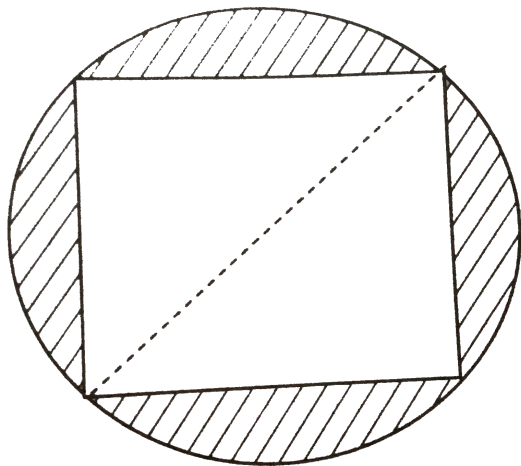

[Watch Video Solution](#)

27. Find the area of a sector of a circle of radius 28cm and central angle  $45^\circ$ .



[Watch Video Solution](#)

**28.** The wheel of a motor cycle is of radius 35 cm. How many revolutions per minute must the wheel make, so as to keep a speed of 66 km/h ?



[Watch Video Solution](#)

**29.** A cow is tied with a rope of length 14m at the corner of a rectangular field of dimensions  $20m \times 16m$  . Find the area of the field in which the cow can graze.





Watch Video Solution

**30.** Find the area of the flower bed (with semi-circular ends) shown in figure.

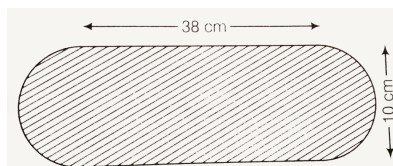

Watch Video Solution

**31.** In figure ,  $AB$  is a diameter of the circle,  $AC = 6\text{cm}$  and  $BC = 8\text{cm}$  . Find the area of the

shaded region . (use  $\pi = 3.14$ )

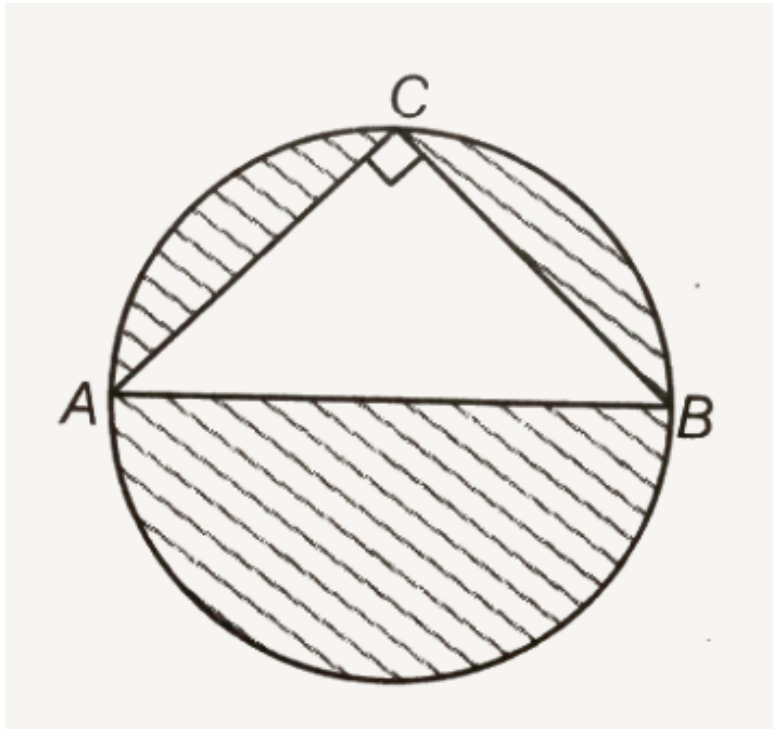

[Watch Video Solution](#)

**32.** Find the area of the shaded field shown in figure.



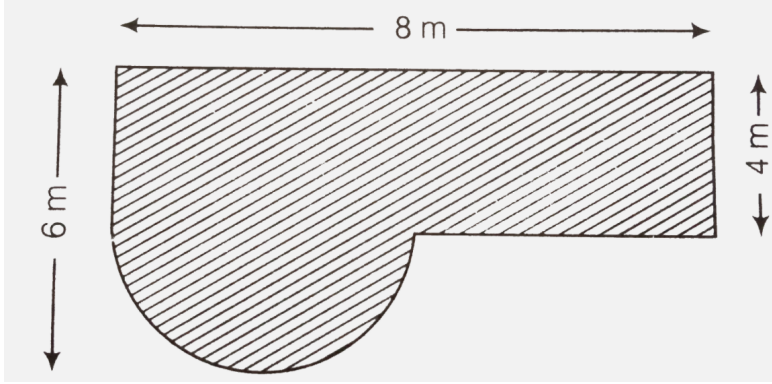

[Watch Video Solution](#)

**33.** Find the area of the shaded region in figure.



[Watch Video Solution](#)

**34.** Find the area of the minor segment of a circle of radius 14cm, when the angle of the corresponding sector is  $60^\circ$



**Watch Video Solution**

**35.** Find the area of the shaded region in figure, in figure, where arcs drawn with centres A, B, C and D intersect in pairs at mid-point P, Q, R and S of the sides AB, BC, CD and DA,

respectively of a square ABCD. (use  $\pi = 3.14$ )



[Watch Video Solution](#)

**36.** In figure arcs are drawn by taking vertices A, B and C of an equilateral triangle of side 10 cm , To intersect the sides BC, CA and AB at their respective mid- points D, E and F. Find the area of the shaded region. (use  $\pi = 3.14$ )



[Watch Video Solution](#)

**37.** In figure arcs have been drawn with radii 14 cm each and with centres P, Q and R. Find the area of the shaded region .



**Watch Video Solution**

**38.** A circular park is surrounded by a road 21 m wide. If the radius of the park is 105 m, then

find the area of the road.

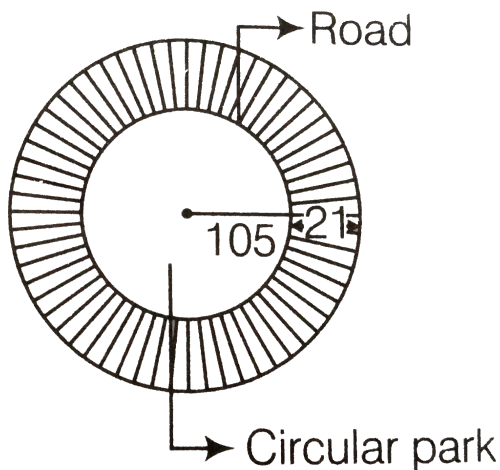

$$[\because \text{area of circle} = \pi r^2]$$



[Watch Video Solution](#)

**39.** In figure, arcs have been drawn of radius 21cm each with vertices A,B,C and D of quadrilateral ABCD as centres . Find the area

of the shaded region.



**Watch Video Solution**

**40.** A piece of wire 20 cm long is bent into the form of an arc of a circle, subtending an angle of  $60^\circ$  at its centre. Find the radius of the circle.

A.  $\frac{60}{\pi}$

B.

C.

D.

**Answer:**



**Watch Video Solution**

**41.** The area of a circular playground is  $22176 \text{ m}^2$ . Find the cost of fencing this ground at the rate of Rs. 50 per m.

A. Rs 20000

B.

C.

D.

**Answer:**



**Watch Video Solution**

**42.** The diameters of front and rear wheels of a tractor are 80 cm and 2m, respectively. Find the number of revolutions that rear wheel will



make in covering a distance in which the front wheel makes 1400 revolutions .



[Watch Video Solution](#)

**43.** Sides of a triangular field are 15 m, 16m and 17m. With the three corners of the field a cow, a buffalo and a horse are tied separately with ropes of length 7m each to graze in the field. Find the area of the field which cannot be grazed by the three animals.



[Watch Video Solution](#)

**44.** Find the area of the segment of a circle of radius 12 cm whose corresponding sector has a central angle of  $60^\circ$ . (use  $\pi = 3.14$ )



[Watch Video Solution](#)

**45.** A circular pond is on diameter 17.5m. It is surrounded by a 2m wide path. Find the cost of constructing the path at the rate of Rs. 25 per square metre.



[Watch Video Solution](#)

**46.** In Figure 6, three circles each of radius 3.5 cm are drawn in such a way that each of them touches the other two. Find the area enclosed between these three circles (shaded region).



**Watch Video Solution**

**47.** Find the area of the sector of a circle of radius 5 cm, if the corresponding arc length is 3.5 cm.

A.  $7 \text{ cm}^2$

B.  $8.75 \text{ cm}^2$

C.  $8.25 \text{ cm}^2$

D.  $7.25 \text{ cm}^2$

**Answer:**  $7 \text{ cm}^2$



**Watch Video Solution**

**48.** Four circular cardboard pieces of radii 7 cm are placed on a paper in such a way that each

piece touches two pieces. Find the area of the portion enclosed between these pieces.



[Watch Video Solution](#)

**49.** On a square cardboard sheet of area  $784\text{cm}^2$ , four congruent circular plates of maximum size are placed such that each circular plate touches the other two plates and each side of the square sheet is tangent to two circular plates. Find the area of the square not covered by the circular plates.



[Watch Video Solution](#)

**50.** All the vertices of a rhombus lie on a circle.

Find the area of the rhombus, if area of the circle is  $1256\text{cm}^2$ . (use  $\pi = 3.14$ )



[Watch Video Solution](#)

**51.** find of the An archery target has three regions formed by three concentric circles as shown in Fig 15.8. If the diameters of the concentric circles are in the ratio  $1:2:3$ , then

find the ratio of the areas of three regions Fig.

15.8



[Watch Video Solution](#)

**52.** The length of the minute hand of a clock is 5cm. Find the area swept by the minute hand during the time period 6:05 am and 6:40 am.

A.  $35 \text{ cm}^2$

B.

C.

D.

**Answer:**



**Watch Video Solution**

**53.** Area of a sector of central angle  $200^\circ$  of a circle is  $770\text{cm}^2$  . Find the length of the corresponding arc of this sector.

A.  $73\frac{1}{3}$  cm

B.  $73\frac{1}{2}$  cm



C.  $72\frac{1}{3}$  cm

D.  $72\frac{1}{2}$  cm

**Answer:**



**Watch Video Solution**

**54.** The central angles of two sectors of circles of radii 7 cm and 21 cm are respectively  $120^\circ$  and  $40^\circ$ . Find the areas of the two sectors as well as the lengths of the corresponding arcs. What do you observe ?



Watch Video Solution

55. Find the number of revolutions made by a circular wheel of area  $1.54m^2$  in rolling a distance of 176 m.

A. 40

B. 30

C. 10

D. 48

**Answer: A**



[Watch Video Solution](#)

**56.** Find the difference of the areas of two segments of a circle formed by a chord of length 5cm subtending an angle of  $90^\circ$  at the centre.



[Watch Video Solution](#)

**57.** Find the areas of a sector of angle  $120^\circ$  and its corresponding major sector of a circle

of radius 21cm.



Watch Video Solution

## Long Answer Type Questions

1. In the given figure ABCD is a trapezium in which

$AB \parallel DC$ ,  $AB = 18\text{cm}$ ,  $DC = 32\text{cm}$  and

the distance between AB and DC is 14 cm. If

arcs of equal radii 7 cm have been drawn with

centres A,B,C and D then find the area of the

shaded region.

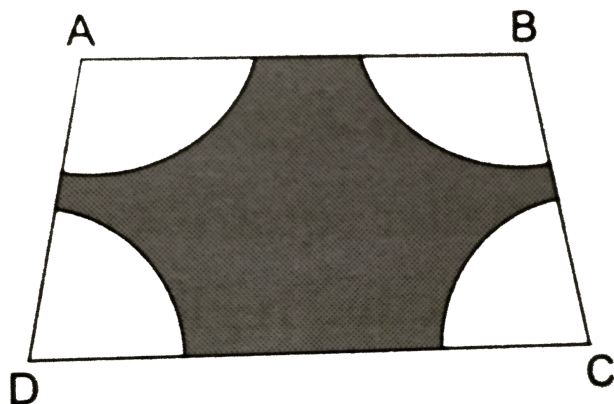

[Watch Video Solution](#)

2. Floor of a room is of dimensions  $5m \times 4m$  and it is covered with circular tiles of diameters 50 cm each as shown in figure . Find

area of floor that remains uncovered with tiles.

(use  $\pi = 3.14$ )



[View Text Solution](#)

**3.** Find the area of the shaded region given in figure.

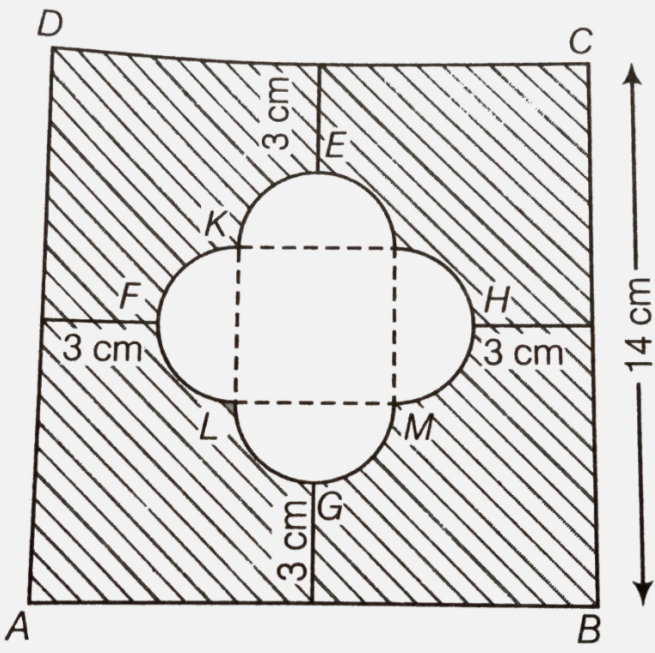

[Watch Video Solution](#)