



# PHYSICS

## BOOKS - NCERT EXEMPLAR PHYSICS (HINGLISH)

### ELECTRICITY

#### Electricity

1. A cell, a resistor, a key and an ammeter are arranged as known in the circuit diagrams of

figure. The current recorded in the ammeter will be

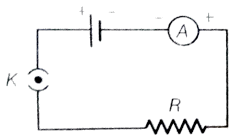

(i)

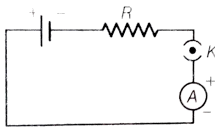

(ii)

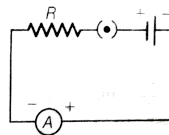

(iii)

- A. maximum in (i)
- B. maximum in (ii)
- C. maximum in (iii)
- D. the same in all the cases

**Answer: D**



**Watch Video Solution**

2. In the following circuits, heat produced in the resistor or combination of resistors connected to a 12 V battery will be

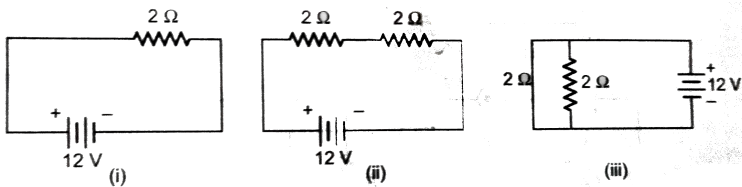

A. same in all the cases

B. maximum in (i)

C. maximum in (ii)

D. maximum in case (iii)

**Answer: D**



**Watch Video Solution**

**3. Electrical resistivity of a given metallic wire depends upon :**

A. its length

B. its thickness

C. its shape

D. nature of the material

**Answer: D**



**Watch Video Solution**

4. A current of  $1A$  is drawn by a filament of an electric bulb. Number of electrons passing through a cross-section of the filament in 16 seconds would be roughly :

A.  $10^{20}$

B.  $10^{16}$

C.  $10^{18}$

D.  $10^{23}$

**Answer: A**



**Watch Video Solution**

5. Identify the circuit, (Fig. 3.39) in which the electrical components have been properly connected.

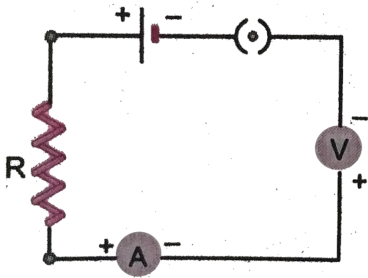

(i)

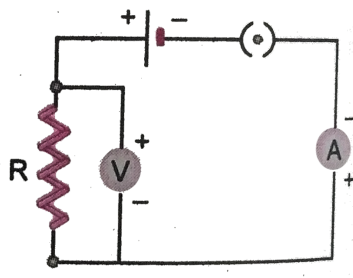

(ii)

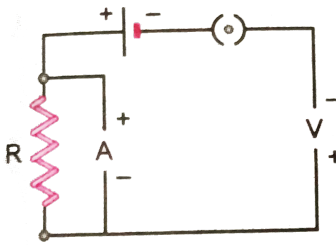

(iii)

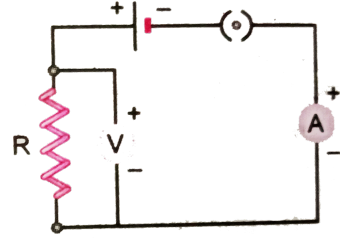

(iv)

A. (i)

B. (ii)

C. (iii)

D. (iv)

**Answer: B**



**Watch Video Solution**

**6. What is the maximum resistance which can be made using five resistors each of  $(1/5)\Omega$  ?**

A.  $1/5\Omega$

B.  $10\Omega$

C.  $5\Omega$

D.  $1\Omega$



**Answer: D**



**Watch Video Solution**

7. What is the minimum resistance which can be made using five resistors each of  $(1/5)\Omega$  ?

A.  $1/5\Omega$

B.  $1/25\Omega$

C.  $1/10\Omega$

D.  $25\Omega$

**Answer: B**



**Watch Video Solution**

**8.** The proper representation of series combination of cells obtaining maximum potential is

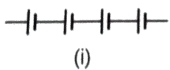

(i)



(ii)

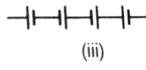

(iii)

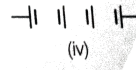

(iv)

A. (i)

B. (ii)

C. (iii)

D. (iv)

**Answer: A**



**Watch Video Solution**

9. Which of the following represents voltage ?

A. 
$$\frac{\text{Work done}}{\text{Current} \times \text{Time}}$$

B.  $\text{Work done} \times \text{Charge}$

C. 
$$\frac{\text{Work Done} \times \text{Time}}{\text{Current}}$$

D. Work done  $\times$  Charge  $\times$  Time

**Answer: A**



**Watch Video Solution**

**10.** A cylindrical conductor of length  $l$  and uniform area of cross-section  $A$  has resistance  $R$ . Another conductor of length  $2l$  and resistance  $R$  of the same material has area of cross-section :

A.  $A/2$

B.  $3A/2$

C.  $2A$

D.  $3A$

**Answer: C**



**Watch Video Solution**

**11.** A student carries out an experiment and plots the  $V - I$  graphs of three samples of nichrome wire with resistances  $R_1$ ,  $R_2$  and  $R_3$  respectively, (Fig. 3.41). Which

of the following is true ?

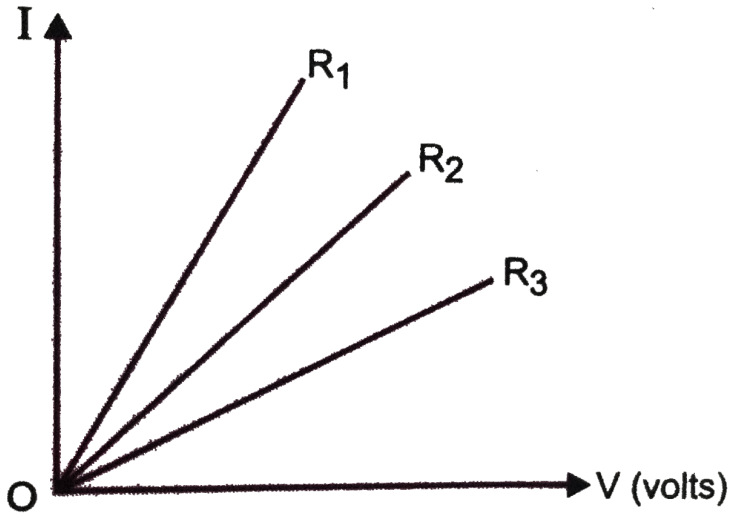

A.  $R_1 = R_2 = R_3$

B.  $R_1 > R_2 > R_3$

C.  $R_3 > R_2 > R_1$

D.  $R_2 > R_3 > R_1$

**Answer: C**



**Watch Video Solution**

**12.** If the current  $I$  through a resistor is increased by 100 % (assume that temperature remains unchanged), the increase in power dissipated will be :

A. 100 %

B. 200 %

C. 300 %

D. 400 %

**Answer: C**



**Watch Video Solution**

**13.** The resistivity does not change if :

A. the material is changed

B. the temperature is changed

C. the shape of the resistor is changed



D. both material and temperature are changed

**Answer: C**



**Watch Video Solution**

**14.** In an electrical circuit three incandescent bulbs  $A$ ,  $B$  and  $C$  of rating  $40W$ ,  $60W$  and  $100W$  respectively are connected in parallel to an electric source.

Which of the following is likely to happen regarding their brightness ?

A. Brightness of all the bulbs will be the same

B. Brightness of bulb A will be the maximum

C. Brightness of bulb B will be more than that of A

D. Brightness of bulb C will be less than that of B

**Answer: C**



**Watch Video Solution**

**15.** In an electrical circuit, two resistors of  $2\Omega$  and  $4\Omega$  respectively are connected in series to a  $6V$  battery. The heat dissipated by the  $4\Omega$  resistor in  $5s$  will be :

A. 5 J

B. 10 J

C. 20 J

D. 30 J

**Answer: C**



**Watch Video Solution**

**16.** An electric kettle consumes  $1kW$  of electric power when operated at  $220V$ . A fuse-wire of what rating must be used for it ?

A.  $1A$

B.  $2A$

C.  $4A$

D.  $5A$

**Answer: D**



**Watch Video Solution**

**17.** Two resistors of resistances  $2\Omega$  and  $4\Omega$  when connected to a battery will have :

A. same current flowing through them when connected in parallel

B. same current flowing through them when connected in series

C. same potential difference across them when connected in series

D. different potential difference across them when connected in parallel

**Answer: B**



**Watch Video Solution**

**18.** Unit of electric power may also be expressed as :

- A. volt ampere
- B. kilowatt hour
- C. watt second
- D. joule second

**Answer: A**



**Watch Video Solution**

19. A child has drawn the electric circuit to study Ohm's law as shown in (Fig. 3.42). His teacher told him that the circuit diagram needs correction. Study the circuit diagram and redraw it after making all corrections.

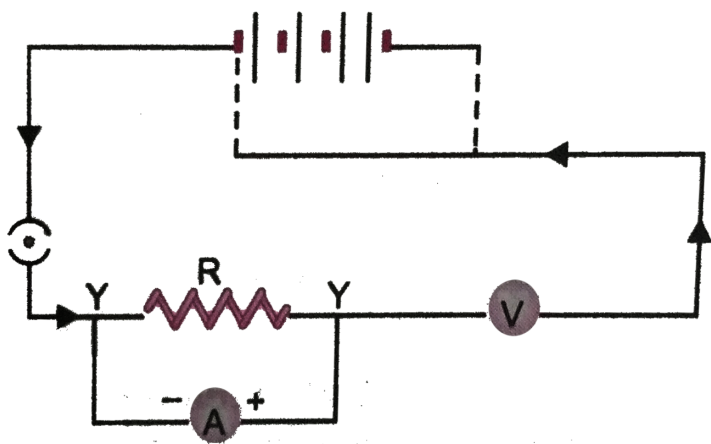

[Watch Video Solution](#)



20. Three  $2\Omega$  resistors, A, B and C are connected as shown in figure. Each of them dissipates energy and can with stand a maximum power of 18 W without melting. Find the maximum current that can flow through the three resistors ?

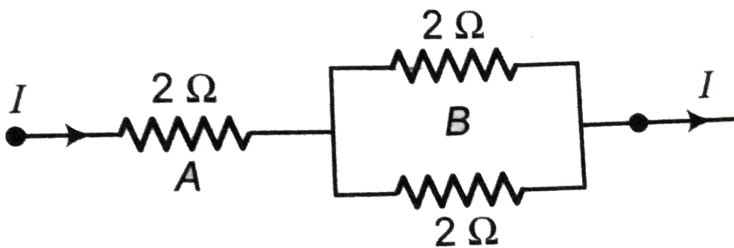

**Watch Video Solution**

**21.** Should the resistance of an ammeter be low or high ? Give reason.



**Watch Video Solution**

**22.** Draw a circuit diagram of an electric circuit containing a cell, a key, an ammeter, a resistance of  $2\Omega$  in series with a combination of two resistors ( $4\Omega$  each) in parallel and a voltmeter across the parallel combination. Will the potential difference across the  $2\Omega$  resistor

be the same as that across the parallel combination of  $4\Omega$  resistors ? Give reason.



[Watch Video Solution](#)

**23.** How does use of a fuse-wire protect electrical appliances ?



[Watch Video Solution](#)

**24.** What is electrical resistivity ? In a series electrical circuit comprising a resistor made

up of a metallic wire, the ammeter reads  $5A$ .

The reading of the ammeter decreases to half when the length of the wire is doubled. Why ?



[Watch Video Solution](#)

**25.** What is the commercial unit of electrical energy ? Represent it in terms of joules.



[Watch Video Solution](#)

**26.** (a) A current of  $1A$  flows in a series circuit containing an electric lamp and a conductor of  $5\Omega$  when connected to a  $10V$  battery. Calculate the resistance of the electric lamp.

(b) Now if a resistance of  $10\Omega$  is connected in parallel with this series combination, what change (if any) in current flowing through  $5\Omega$  conductor and potential difference across the lamp will take place ? Give reason.



**Watch Video Solution**

27. Why is parallel arrangement used in domestic wiring ?



[Watch Video Solution](#)

28.  $B_1$ ,  $B_2$  and  $B_3$  are three identical bulbs connected as shown in (fig. 3.46). When all the three bulbs glow, a current of  $3A$  is recorded by the ammeter  $A$ .

(i) What happens to the glow of the other two bulbs when the bulb  $B_1$  gets fused ?

(ii) What happens to the readings of

$A_1$ ,  $A_2$ ,  $A_3$  and  $A$  when the bulb  $B_2$  gets fused ?

(iii) How much power is dissipated in the circuit when all the three bulbs glow together ?

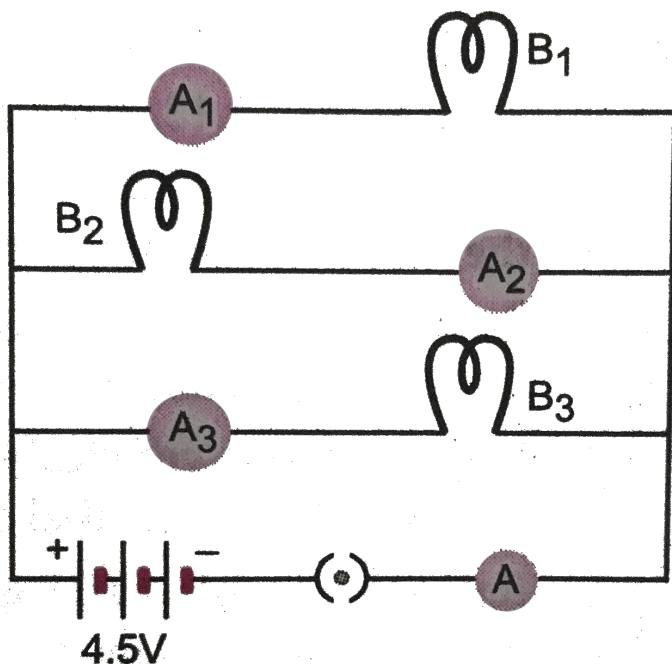

Watch Video Solution

**29.** Three incandescent bulbs of  $100W$  each are connected in series in an electric circuit. In another circuit another set of three bulbs of the same wattage are connected in parallel to the same source.

(a) Will the bulbs in the two circuits glow with the same brightness ? Justify your answer.

(b) Now let one bulb in both the circuits get fused. Will the rest of the bulbs continue to glow in each circuit ? Give reason.



**Watch Video Solution**



**30.** State Ohm's law ? How can it be verified experimentally ? Does it hold good under all conditions ? Comment.



**Watch Video Solution**

**31.** What is electrical resistivity ? How does it depend on temperature. Give its *SI* unit.



**Watch Video Solution**

**32.** How will you infer with the help of an experiment that the same current flows through every part of the circuit containing three resistances in series connected to a battery?



**Watch Video Solution**

**33.** How will you conclude that the same potential difference (voltage) exists across

three resistors connected in a parallel arrangement to a battery ?



[Watch Video Solution](#)

**34.** What is Joule's heating effect ? How can it be demonstrated experimentally ? List its four applications in daily life.



[Watch Video Solution](#)

**35.** Find out the following in the electric circuit given in (Fig. 3.48).

(a) Effective resistance of two  $8\Omega$  resistors in the combination

(b) Current flowing through  $4\Omega$  resistor

(c) Potential difference across  $4\Omega$  resistance

(d) Power dissipated in  $4\Omega$  resistor

(e) Difference in ammeter readings, if any.

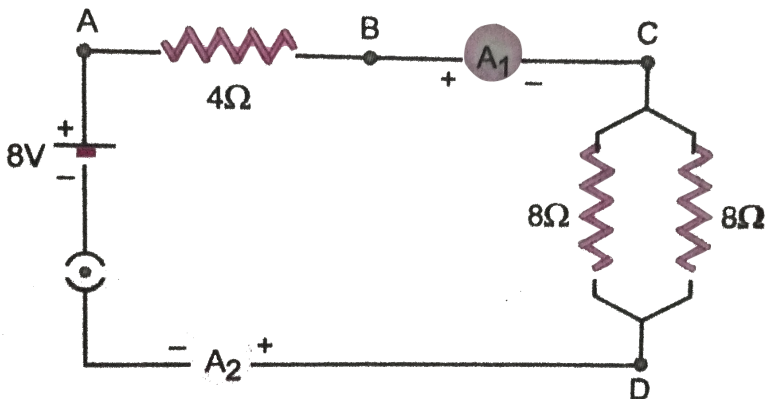



**Watch Video Solution**