



PHYSICS

BOOKS - NCERT EXEMPLAR PHYSICS (HINGLISH)

MAGNETIC EFFECTS OF ELECTRIC CURRENT

Magnetic Effects Of Electric Current

1. Choose the incorrect statement from the following regarding magnetic lines of field:

A. The direction of magnetic field at point is taken to be the direction in which the North pole of a magnetic compass needles points

B. Magnetic field lines are closed curves

C. If magnetic field lines are parallel and equidistant, they represent zero field

strength

D. Relative strength of magnetic field is shown by the degree of closeness of the field lines

Answer: C



Watch Video Solution

2. If the key in the arrangement, [figure] is taken out (the circuit is made open) and magnetic field lines are drawn over the

horizontal plane ABCD, the lines are:

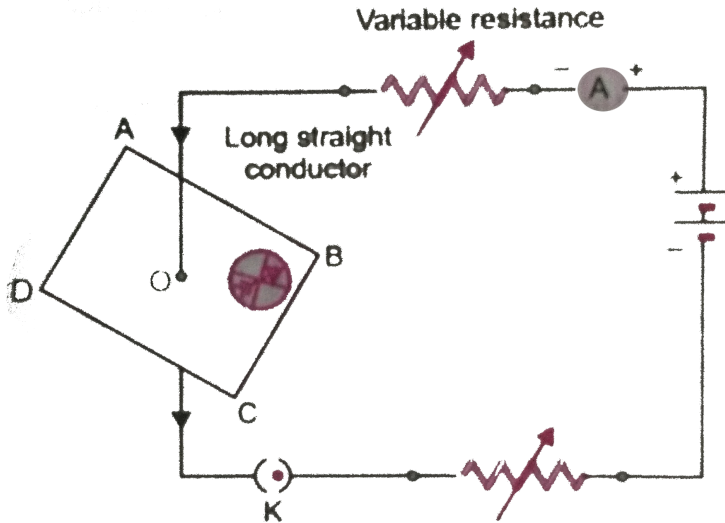

A. Concentric circles

B. Elliptical in shape

C. Straight lines parallel to each other

D. Concentric circles near the point O but of elliptical shapes as we go away from it

Answer: C



Watch Video Solution

3. A circular loop placed in a plane perpendicular to the plane of paper carries a current when the key is ON, [figure]. The current as seen from points A and B (in the plane of paper and on the axis of the coil) is anticlockwise and clockwise respectively. The magnetic field lines point from B to A. The N-pole of the resultant magnet is on the face

close to:

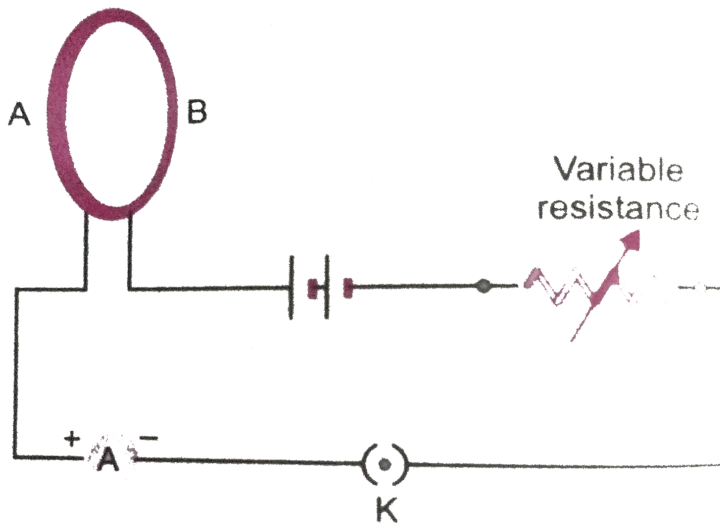

A. A

B. B

C. A if the current is small and B if the current is large

D. B if the current is small and B if the current is large

Answer: A



Watch Video Solution

4. For a current in a long straight solenoid, $N \cdot$ and $S -$ poles are created at the two ends. Among the following statements, the incorrect statement is:

A. The field lines inside the solenoid are in the form of straight lines, which indicates that the magnetic field is the same at all points inside the solenoid

B. The strong magnetic field produced inside the solenoid can be used to magnetise a piece of magnetic material like soft iron, when placed inside the coil

C. The pattern of the magnetic field associated with the solenoid is different

from the pattern of the magnetic field
around a bar magnet

D. The N and S-poles exchange position
when the direction of current through
the solenoid is reversed

Answer: C



Watch Video Solution

5. A uniform magnetic field exists in the plane of paper pointing from left to right as shown in figure. In the field, an electron and a proton move as shown. The electron and the proton experience:

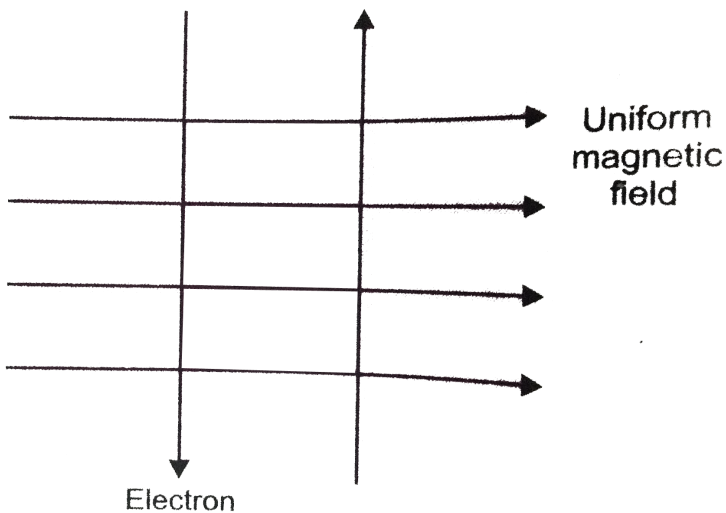

A. Forces both pointing into the plane of
paper

B. Forces both pointing out the plane of
paper

C. Forces pointing into the plane of paper
and out of the plane of paper,
respectively

D. Force pointing opposite and along the
direction of the uniform magnetic field
respectively

Answer: A



Watch Video Solution

6. Commercial electric motors do not use:

A. An electromagnet to rotate the armature

B. Effectively large number of turns of conducting wire in the current carrying coil

C. A permanent magnet to rotate the armature

D. A soft iron core on which the coil is wound

Answer: C



Watch Video Solution

7. In the arrangement shown in figure, there are two coils wound on a non-conducting cylindrical rod. Initially the key is not inserted.

Then the key is inserted and later removed.

Then:

A. The deflection in the galvanometer remains zero throughout

B. There is a momentary deflection in the galvanometer but it dies out shortly and there is no effect when the key is removed.

C. There are momentary galvanometer deflections that die out shortly, the

deflections are in the same direction.

D. There are momentary galvanometer deflections that die out shortly, the deflections are in opposite directions.

Thus the galvanometer shows momentary deflections in opposite directions.

Answer: D



Watch Video Solution

8. Choose the incorrect statement:

A. Fleming's right hand rule is a simple rule of thumb to know the direction of induced current.

B. The right hand thumb rule is used to find the direction of magnetic fields due to current carrying conductors.

C. The difference between the direct and alternating current is that the direct

current always flows in one direction,
where as the alternating cuurrent
reverses its direction periodically.

D. In India, the AC changes direction after
every $\frac{1}{50}$ second.

Answer: D



Watch Video Solution

9. A constant current flows in a horizontal wire in the plane of the paper from east to west as shown in figure. The direction of magnetic field at a point will be North to South:

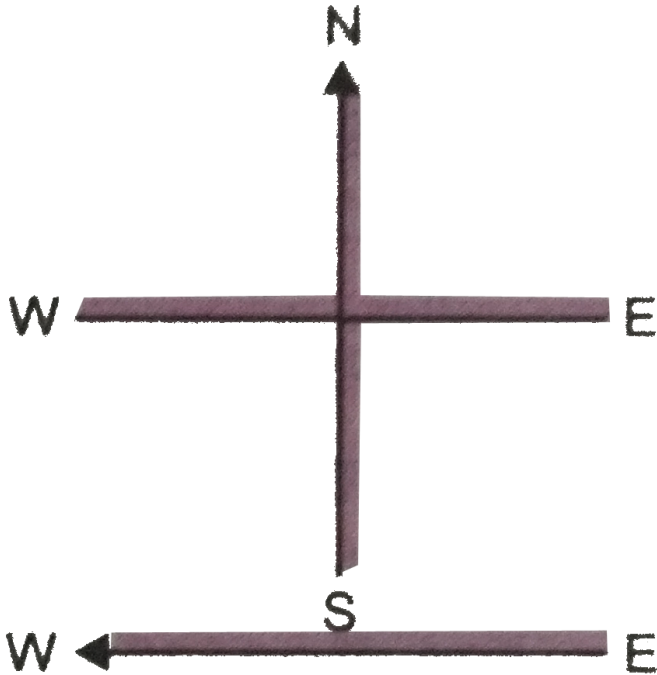

A. Directly above the wire

B. Directly below the wire

C. At a point located in the plane of the paper on the north side of the wire.

D. At a point located in the plane of the paper on the south side of the wire.

Answer: B



Watch Video Solution

10. The strength of magnetic field inside a long current-carrying straight solenoid is:

A. more at the ends than at the centre

B. minimum in the middle

C. same at all points

D. found to increase from one end to the other

Answer: C



Watch Video Solution

11. The convert an AC generator into DC generator:

A. split ring type commutator must be used

B. slip rings and brushes must be used

C. a stronger magnetic field has to be used

D. a rectangular wire loop has to be used

Answer: A



Watch Video Solution

12. The most important safety method used for protecting home appliances from short-circuiting or overloading is:

- A. earthing
- B. use of fuse
- C. use of stabilizers
- D. use of electric meter

Answer: B



13. A magnetic compass needle is placed in the plane of paper near point A as shown in figure. In which plane should a straight current carrying conductor be placed so that it passes through A and there is no change in the direction of the compass? Under what

condition is the deflection maximum and why?

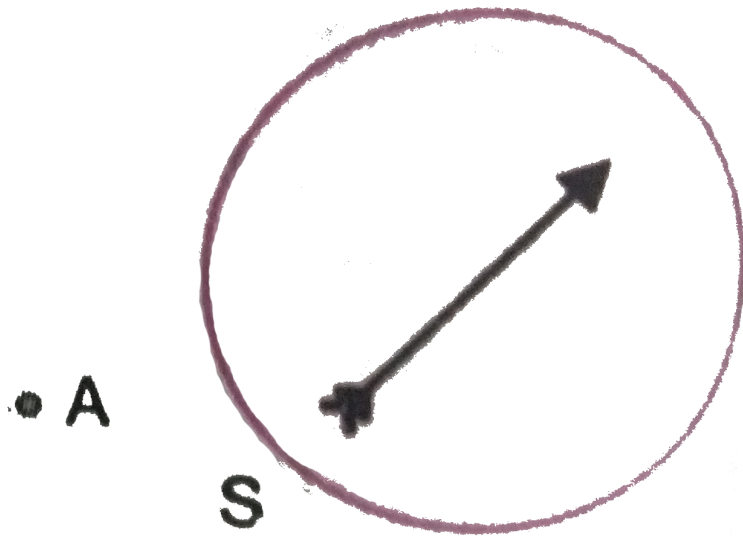

 [Watch Video Solution](#)

14. Under what conditions a permanent electromagnet is obtained if a current carrying

solenoid is used? Support your answer with the help of a labelled circuit diagram.



Watch Video Solution

15. AB is a current-carrying conductor in the plane of the paper as shown in figure. What are the directions of magnetic fields produced by it at point P and Q? Given $r_1 > r_2$, where will the strength of the magnetic field be

larger?

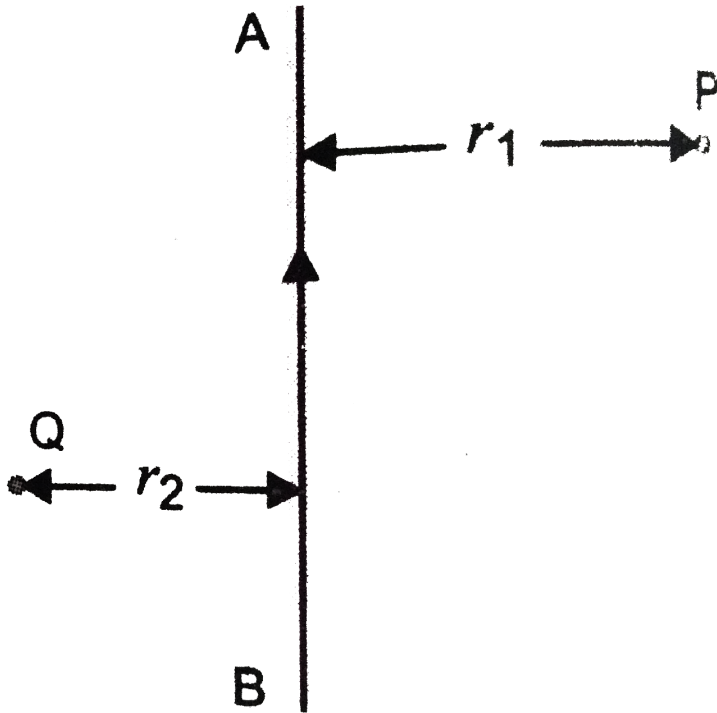

Watch Video Solution

16. A magnetic compass shows a deflection when placed near a current-carrying wire. How

will the deflection of the compass get affected if the current in the wire is increased? Support your answer with a reason.



[Watch Video Solution](#)

17. It is established that an electric current through a metallic conductor produces a magnetic field around it. Is there a similar magnetic field produced around a thin beam of moving (i) alpha particles, (ii) neutrons? Justify your answer.



[Watch Video Solution](#)

18. What does the direction of thumb indicate in the right-hand thumb rule? In what way this rule is different from Fleming's left-hand rule?



[Watch Video Solution](#)

19. Meena draws magnetic field lines of field close to the axis of a current-carrying circular loop. As she moves away from the centre of the circular loop, she observes that the lines

keep on diverging. How will you explain her observation?



[Watch Video Solution](#)

20. What does the divergence of magnetic field lines near the ends of a current carrying straight solenoid indicate?



[Watch Video Solution](#)

21. Name four appliances wherein an electric motor, a rotating device that converts electrical energy to mechanical energy, is used as an important component. In what respect motors are different from generators?



[Watch Video Solution](#)

22. What is the role of the two conducting stationary brushes in a simple electric motor?



[Watch Video Solution](#)

23. What is the difference between a direct current and an alternating current? How many times does AC used in India change direction in one second?



Watch Video Solution

24. What is the role of fuse, used in series with any electrical appliance? Why should a fuse with defined rating not be replaced by one with a larger rating?



[Watch Video Solution](#)

25. Why does a magnetic compass needle pointing North and South in the absence of a nearby magnet get deflected when a bar magnet or a current-carrying loop is brought near it. Describe some salient features of magnetic lines of field concept.



[Watch Video Solution](#)

26. With the help of a labelled circuit diagram, illustrate the pattern of field lines of the magnetic field around a current-carrying straight long conducting wire. How is the right hand thumb rule useful to find direction of magnetic field associated with a current-carrying conductor?



Watch Video Solution

27. Explain with the help of a labelled diagram the distribution of magnetic field due to a current through a circular loop. Why is it that if a current carrying coil has n turns, the field produced at any point is n times as large as that produced by a single turn?



Watch Video Solution

28. Describe the activity that shows that a current-carrying conductor experiences a force

perpendicular to its length and the external magnetic field. How does Fleming's left-hand rule help us to find the direction of the force acting on the current carrying conductor?



[Watch Video Solution](#)

29. Draw a labelled circuit diagram of a simple electric motor and explain its working. In what way these simple electric motors are different from commercial motors?



[Watch Video Solution](#)

30. Explain the phenomenon of electromagnetic induction. Describe an experiment to show that a current is set up in a closed loop when an external magnetic field passing through the loop increases or decreases.



Watch Video Solution

31. Describe the working of an AC generator with the help of a labelled circuit diagram.

What charges must be made in the arrangement to convert it to a DC generator?



[Watch Video Solution](#)

32. Draw an appropriate schematic diagram showing common domestic circuits and discuss the importance of fuse. Why is it that a burnt out fuse should be replaced by another fuse of identical rating?



[Watch Video Solution](#)

