



PHYSICS

BOOKS - NCERT PHYSICS (HINGLISH)

MOVING CHARNGES AND MAGNETISM

Moving Charnges And Magnetism

1. Two charged particles traverse identical helical paths in a completely opposite sense in

a uniform magnetic field $\vec{B} = B_0 \hat{K}$

- A. They have equal z-components of momenta
- B. They must have equal charges.
- C. They necessarily represent a particle, anti particle pair
- D. The charge to mass ratio satisfy.

Answer: D



Watch Video Solution

2. Biot-Savart law indicates that the moving electrons (velocity \vec{v}) produce a magnetic field \vec{B} such that

A. B is perpendicular of

B. B is parallel to V

C. it obeys inverse cube law

D. It is along the line joining the electron
and point of observation.

Answer: A



3. A current carrying circular loop of radius R is placed in the x - y plane with centre at the origin. Half of the loop with $x > 0$ is now bent so that it now lies in the y - z plane.

A. The magnitude of magnetic moment now diminishes.

B. The magnetic moment does not change.

C. The magnitude of B at $(0,0,z)$, $z > R$ increases.

D. The magnitude of B at $(0,0,z)$, $z > R$

is unchanged.

Answer: A



Watch Video Solution

4. An electron is projected with uniform velocity along the axis of a current carrying long solenoid. Which of the following is true?

A. The electron will be accelerated along the axis

B. The electron path will be circular about the axis.

C. the electron Will experience a force at 45° to the axis and hence execute a helical path.

D. The electron will continue to move with uniform velocity along the axis of the solenoid.

Answer: D



Watch Video Solution

5. In a cyclotron, a charged particle

A. undergoes acceleration all the time.

B. Speeds up between the dees because of
the magnetic field

C. speeds up in a dae.

D. slows down within a dee and speeds up
between dees.

Answer: A



Watch Video Solution

6. A circular current loop of magnetic moment M is in an arbitrary orientation in an external magnetic field \vec{B} . The work done to rotate the loop by 30° about an axis perpendicular to its plane is :

A. MB

B. $\sqrt{3}\frac{MB}{2}$

C. $\frac{MB}{2}$

D. zero

Answer: A



Watch Video Solution

7. The gyro-magnetic ratio of an electron in an H-atom, according to Bohr model, is

A. independent of which orbit it is in

B. negative

C. positive

D. increases with the quantum number n .

Answer: A



Watch Video Solution

8. Consider a wire carrying a steady current, I placed in a uniform magnetic field \vec{B} perpendicular to its length. Consider the

charges inside the wire. It is known that magnetic forces do not work. This implies that

A. Motion of charges inside the conductor is unaffected by B , since they do not absorb energy

B. some charges inside the wire move to the surface as a result of B

C. if the wire moves under the influence of B , no work is done by the force.

D. If the wire moves under the influence of B , no work is done by the magnetic force on the ions, assumed fixed within the wire.

Answer: B::D



Watch Video Solution

9. Two identical current carrying coaxial loops, carry current I in an opposite sense. A simple

amperian loop passes through both of them once. Calling the loop as C,

A. $\oint B \cdot dl = \mu_0 I$

B. The value of $\oint B \cdot dl = \mu_0 I$ is independent of sense of C.

C. There may be a point of C where, B and dl are perpendicular

D. B vanishes everywhere on C.

Answer: B::C



Watch Video Solution

10. A cubical region of space is filled with some uniform electric and magnetic fields. An electron enters the cube across one of its faces with velocity \vec{v} and a positron enters via opposite face with velocity $-\vec{v}$. At this instant,

A. the electric forces on both the particles cause identical accelerations

B. the magnetic forces on both the particles cause equal acceleration.

C. Both particles gain or lose energy at the same rate

D. the motion of the centre of mass (CM) is determined by B alone.

Answer: B::C::D



Watch Video Solution

11. A charged particle would continue to move with a constant velocity in a region wherein,

A. $E = 0, B \neq 0$

B. $E \neq 0, B \neq 0$

C. $E \neq 0, B = 0$

D. $E = 0, B = 0$

Answer: A::B::D



Watch Video Solution

12. Verify that the cyclotron frequency $\omega = eB/m$ has the correct dimensions of $[T]^{-1}$.



Watch Video Solution

13. Show that a force that does no work must be a velocity dependent force.



Watch Video Solution

14. The magnetic force depends on \vec{v} which depends on the inertial frame of reference. Does then the magnetic force differ from inertial frame to frame? Is it reasonable that the net acceleration has a different value in different frames of reference?



Watch Video Solution

15. Describe the motion of a charged particle in a cyclotron if the frequency of the radio

frequency (rf) field were doubled.



Watch Video Solution

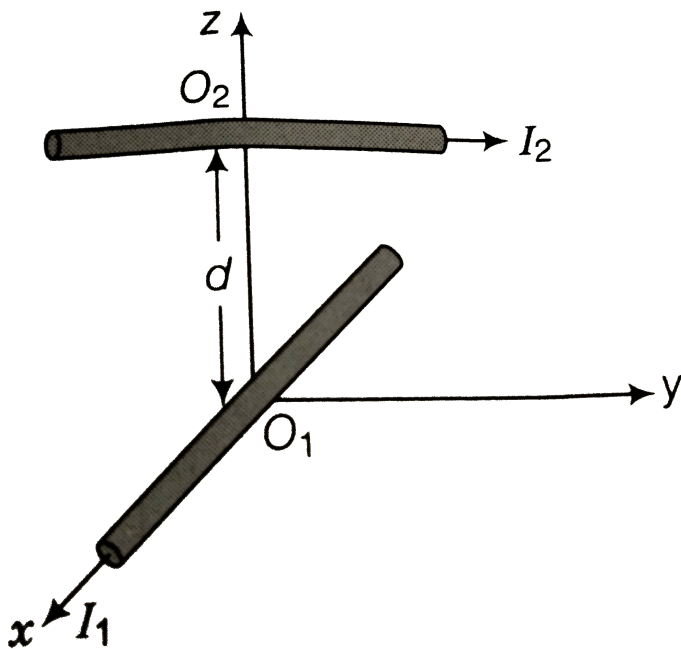

16.

Two long wires carrying current I_1 and I_2 are arranged as shown in figure the one carrying

current I_1 is along the x-axis. The other carrying current I_2 is along a line parallel to the y-axis given by $x=0$ and $z=d$. Find the force exerted at O_2 because of the wire along the x-axis.



[Watch Video Solution](#)

17. A current carrying loop consists of 3 identical quarter circles of radius R , lying in the positive quadrants of the x-y, y-z and z-x planes with their centres at the origin, joined

together. Find the direction and magnitude to \vec{B} at the origin.



[Watch Video Solution](#)

18. A charged particle of charge e and mass m is moving in an electric field \vec{E} and magnetic field \vec{B} . Constant dimensionless quantities and quantities of dimension $[T]^{-1}$.



[Watch Video Solution](#)

19. An electron enters with a velocity $\vec{v} = v_0 \hat{i}$ into a cubical region (faces parallel to coordinate planes) in which there are uniform electric and magnetic fields. The orbit of the electron is found to spiral down inside the cube in plane parallel to the x-y plane. Suggest a configuration of fields \vec{E} and \vec{B} that can lead to it.



Watch Video Solution

20. Do magnetic forces obey Newton's third law. Verify for two current elements $d\vec{l}_1 = dl\hat{i}$ located at the origin and $d\vec{l}_2 = dl\hat{j}$ located at $(0, R, 0)$. Both carry current I .



[Watch Video Solution](#)

21. A multirange voltmeter can be constructed by using a galvanometer circuit as shown in figure. We want to construct a voltmeter that

can measure 2V, 20V and 200V using a galvanometer of resistance 10Ω and that produces maximum deflection for current of $1mA$. Find R_1 , R_2 and R_3 that have to be

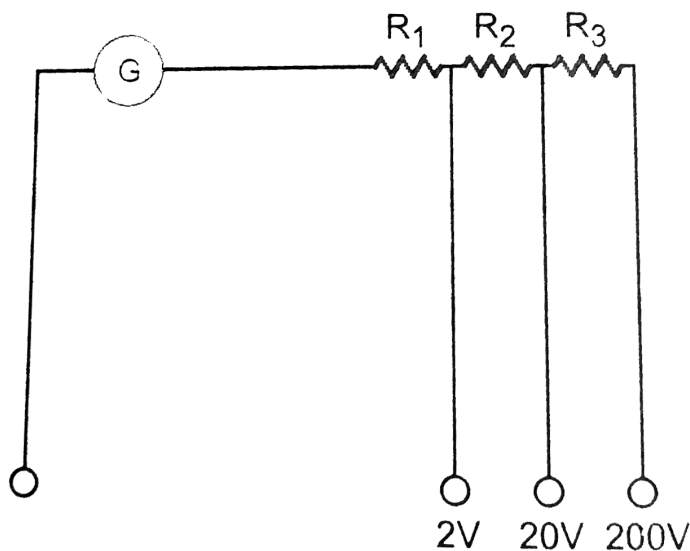

used.



[Watch Video Solution](#)

22. A long straight wire carrying current of $25A$ rests on a table as shown in figure. Another wire PQ of length $1m$, mass $2.5g$ carries the same current but in the opposite direction. The wire PQ is free to slide up and down. To what height will PQ rise?

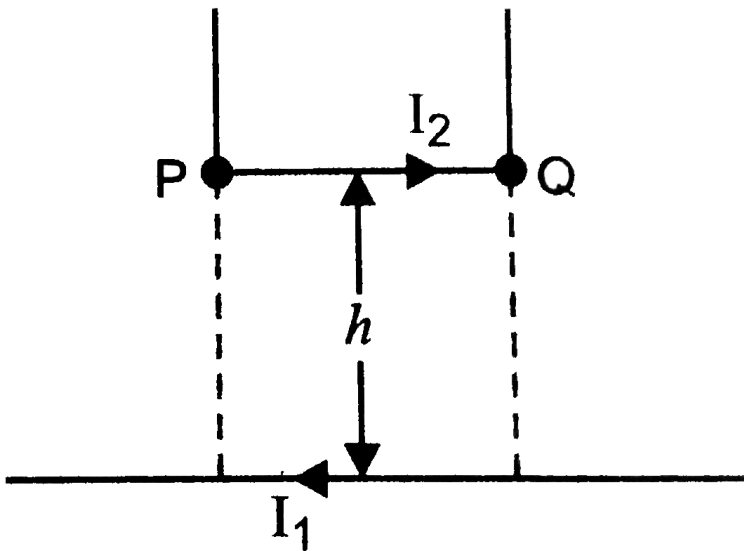



Watch Video Solution

23. A 100 turn rectangular coil ABCD (in XY plane) is hung from one arm of a balance (figure). A mass $500g$ is added to the other arm to balance the weight of the coil. A current $4.9A$ passes through the coil and a constant magnetic field of $0.2T$ acting inward (in xz plane) is switched on such that only arm CD of length $1cm$ lies in the field. How much additional mass 'm' must be added

to regain the balance?

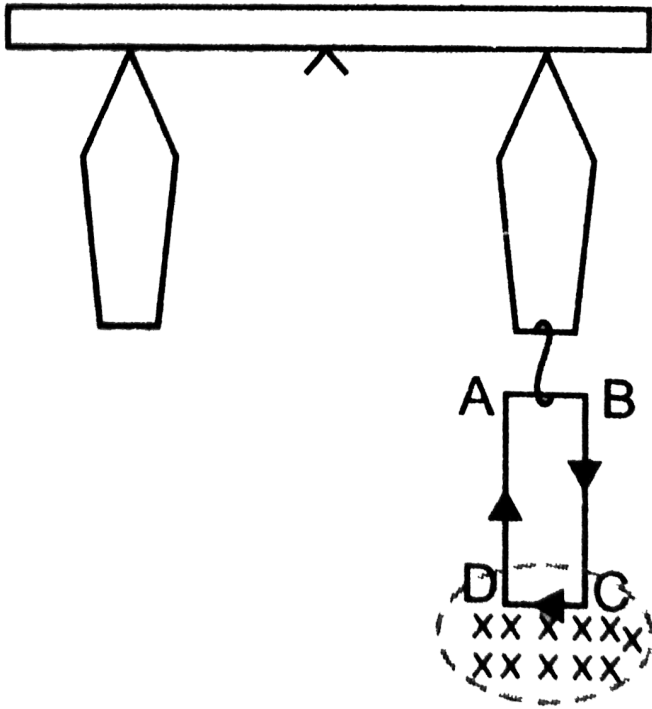

[Watch Video Solution](#)

24. A rectangular conducting loop consists of two wires on two opposite sides of length l joined together by rods of length d . The wires are each of the same material but with cross-sections differing by a factor of 2. The thicker wire has a resistance R and the rods are of low resistance, which in turn are connected to a constant voltage source V_0 . The loop is placed in a uniform magnetic field B at 45° to its plane. Find τ , the torque exerted by the magnetic field on the loop about an axis through the centres of rods.



Watch Video Solution

25. An electron and a positron are released from $(0, 0, 0)$ and $(0, 0, 1.5R)$ respectively, in a uniform magnetic field $\vec{B} = B_0 \hat{i}$, each with an equal momentum of magnitude $p = eBR$. Under what conditions on the direction of momentum will the orbits be non-intersecting circles?



Watch Video Solution

26. A uniform conducting wire of length $12a$ and resistance R is wound up as a current carrying coil in the shape of (i) an equilateral triangle of side a , (ii) a square of sides a and, (iii) a regular hexagon of sides a . The coil is connected to a voltage source V_0 . Find the magnetic moment of the coils in each case.



Watch Video Solution

27. Consider a circular current-carrying loop of radius R in the x - y plane with centre at origin.

Consider the line integral

$$\zeta(L) = \left| \int_{-L}^L \vec{B} \cdot d\vec{l} \right| \text{ taken along z-axis.}$$

(a) Show that $\zeta(L)$ monotonically increases with L .

(b) Use an appropriate Amperian loop to show that $\zeta(\infty) = \mu_0 I$, where I is the current in the wire.

(c) Verify directly the above result.

(d) Suppose we replace the circular coil by a square coil of sides R carrying the same current I . What can you say about $\zeta(L)$ and $\zeta(\infty)$?



28. A multirange current meter can be constructed by using a galvanometer circuit as shown in figure. We want a current meter that can measure $10mA$, $100mA$ and $1A$ using a galvanometer of resistance 10Ω and that produces maximum deflection for current of

1mA . Find S_1 , S_2 and S_3 that have to be used.

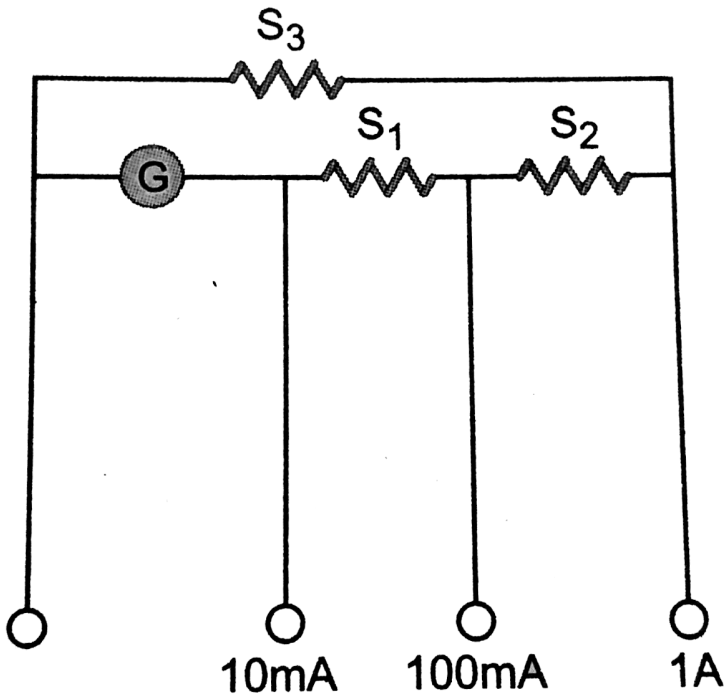

Watch Video Solution

29. Five long wires A, B, C, D and E, each carrying current I are arranged to form edges of a pentagonal prism as shown in figure. Each carries current out of the plane of paper.

(a) What will be magnetic induction at a point on the axis O? Axis is at a distance R from each wire.

(b) What will be the field if current in one of the wires (say A) is switched off?

(c) What if current in one of the wire (say) A is reversed?



Watch Video Solution

