



## PHYSICS

### BOOKS - DC PANDEY PHYSICS (HINGLISH)

#### CENTRE OF MASS

#### Example

1. Two particles of masses 1kg and 2kg are located at  $x = 0$  and  $x = 3m$ .

Find the position of their centre of mass.

- A. 2m from 1 kg
- B. 2m from 2 kg
- C. 1m from 1 kg
- D. none of these

**Answer: A**



Watch Video Solution

2. The position vector of three particles of masses  $m_1 = 1\text{kg}$ .

$m_2 = 2\text{kg}$  and  $m_3 = 3\text{kg}$  are  $r_1 = (\hat{i} + 4\hat{j} + \hat{k})m$ ,  $r_2 = (\hat{i} + \hat{j} + \hat{k})m$

and  $r_3 = (2\hat{j} - \hat{j} - 2\hat{k})m$  respectively. Find the position vector of their centre of mass.

A.  $(1.5\hat{i} + 0.5\hat{j} - 0.5\hat{k})m$

B.  $(0.5\hat{i} + 1.5\hat{j} - 0.5\hat{k})m$

C.  $(1.5\hat{i} + 0.5\hat{j} + 0.5\hat{k})m$

D.  $(\hat{i} + 0.5\hat{j} - 0.5\hat{k})m$

**Answer: A**



Watch Video Solution

3. Four particles of masses 1kg, 2kg, 3kg and 4kg are placed at the four vertices A, B, C and D of a square of side 1m. Find the position of centre of

mass of the particles.

A. (0.5, 0.3)

B. (0.4, 0.3)

C. (0.5, 0.8)

D. (0.7, 0.3)

**Answer: A**



[Watch Video Solution](#)

**4.** A rod of length  $L$  is placed along the  $x$ -axis between  $x = 0$  and  $x = L$ .

The linear mass density (mass/length)  $\rho$  of the rod varies with the distance  $x$  from the origin as  $\rho = a + bx$ . Here,  $a$  and  $b$  are constants.

Find the position of centre of mass of this rod.



[Watch Video Solution](#)

5. Find the position of centre of mass of the uniform lamina shown in figure.

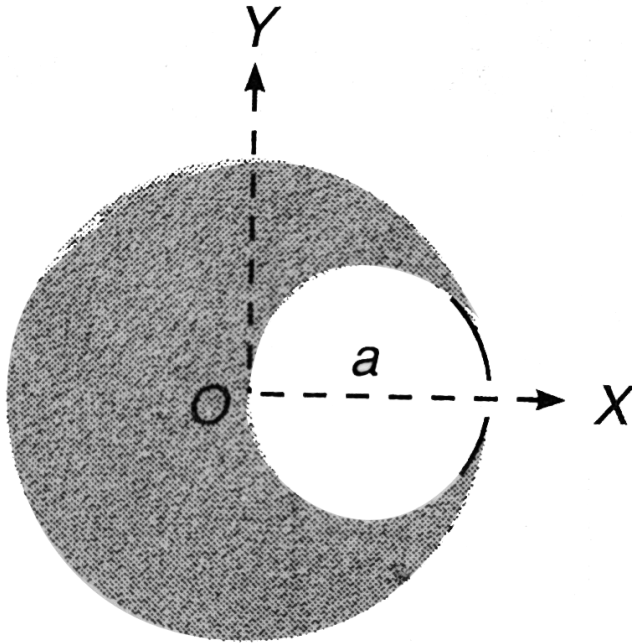

**Fig 11 12**

[Watch Video Solution](#)

6. Two particles A and B of masses 1kg and 2kg respectively are projected in the directions shown in figure with speeds  $u_A = 200m/s$  and  $u_B = 50m/s$ . Initially they were 90m apart. They collide in mid air and

stick with each other. Find the maximum height attained by the centre of mass of the particles. Assume acceleration due to gravity to be constant.

$$(g = 10\text{m/s}^2)$$

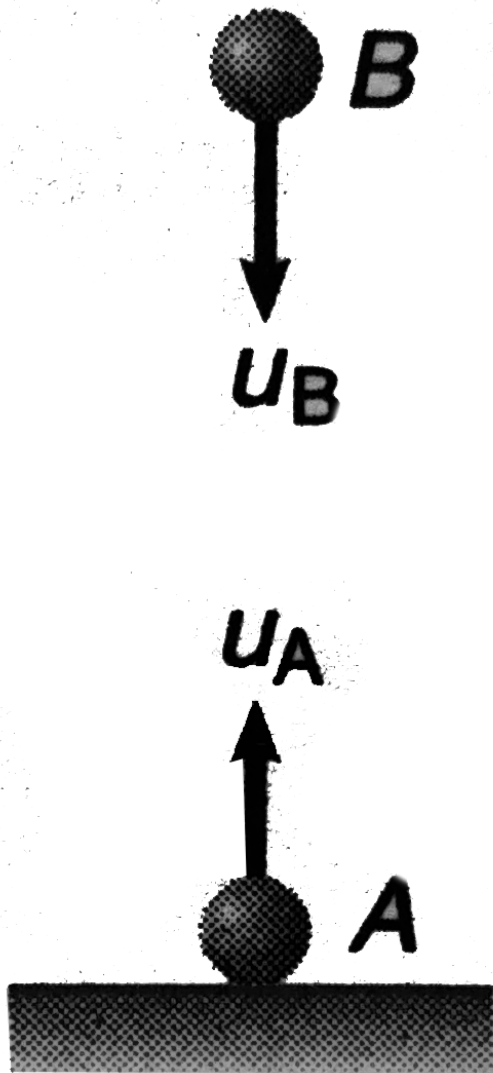

 Watch Video Solution

7. In the arrangement shown in Figure,  $m_A = 2\text{kg}$  and  $m_B = 1\text{kg}$ . String is light and inextensible. Find the acceleration of centre of mass of both the blocks. Neglect friction everywhere.

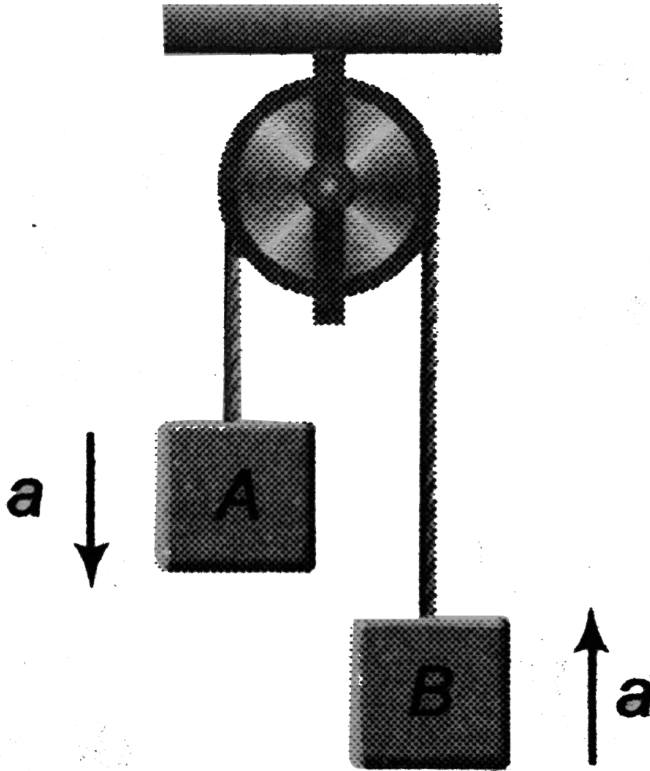

Watch Video Solution

8. Two blocks A and B of equal masses are released on two sides of a fixed wedge C as shown in figure. Find the acceleration of centre of mass of blocks A and B. Neglect friction.

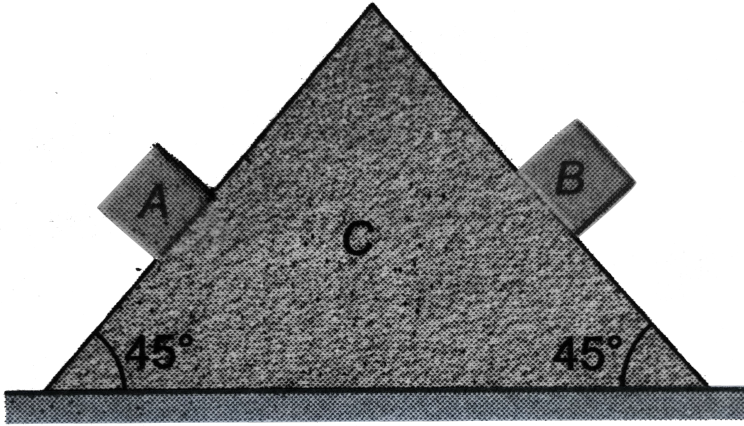

[▶ Watch Video Solution](#)

9. Linear momentum of particle is increased by

(a) 100% (b) 1%

without changing its mass. Find percentage increase in its kinetic energy in both cases.

[▶ Watch Video Solution](#)



10. Kinetic energy of a particle is increased by

(a) 50% (b) 1%

Find percentage change in linear momentum.



[Watch Video Solution](#)

11. Two blocks A and B of masses 1kg and 2kg are connected together by means of a spring and are resting on a horizontal frictionless table. The blocks are then pulled apart so as to stretch the spring and then released. Find the ratio of their,

(a) speed

(b) magnitude of momentum and

(c) kinetic energy at any instant.



[Watch Video Solution](#)

12. A gun (mass= $M$ ) fires a bullet (mass= $m$ ) with speed  $v_r$  relative to barrel of the gun which is inclined at an angle of  $60^\circ$  with horizontal. The gun

is placed over a smooth horizontal surface. Find the recoil speed of gun.



[Watch Video Solution](#)

**13.** A projectile of mass  $3m$  is projected from ground with velocity  $20\sqrt{2}m/s$  at  $45^\circ$ . At highest point it explodes into two pieces. One of mass  $2m$  and the other of mass  $m$ . Both the pieces fly off horizontally in opposite directions. Mass  $2m$  falls at a distance of  $100m$  from point of projection. Find the distance of second mass from point of projection where it strikes the ground.

$$(g = 10m/s^2)$$



[Watch Video Solution](#)

**14.** (a) A rocket set for vertical firing weighs  $50kg$  and contains  $450kg$  of fuel. It can have a maximum exhaust velocity of  $2km/s$ . What should be its minimum rate of fuel consumption

(i) to just lift off the launching pad?

(ii) to give it an initial acceleration of  $20m/s^2$ ?

(b) What will be the speed of the rocket when the rate of consumption of fuel is  $10\text{kg}/\text{s}$  after whole of the fuel is consumed? (Take  $g = 9.8\text{m}/\text{s}^2$ )

 [Watch Video Solution](#)

15. A ball of mass  $200\text{g}$  is projected with a density of  $30\text{m}/\text{s}$  at  $30^\circ$  from horizontal. Using the concept of impulse, find change in velocity in  $2\text{s}$ . Take  $g = 10\text{m}/\text{s}^2$ .

 [Watch Video Solution](#)

16. A time varying force,  $F = 2t$  is acting on a particle of mass  $2\text{kg}$  moving along x-axis. velocity of the particle is  $4\text{m}/\text{s}$  along negative x-axis at time  $t = 0$ . Find the velocity of the particle at the end of  $4\text{s}$ .

 [Watch Video Solution](#)

17. A particle of mass  $2\text{kg}$  is initially at rest. A force starts acting on it in one direction whose magnitude changes with time. The force time graph is shown in figure. Find the velocity of the particle at the end of  $10\text{s}$ .

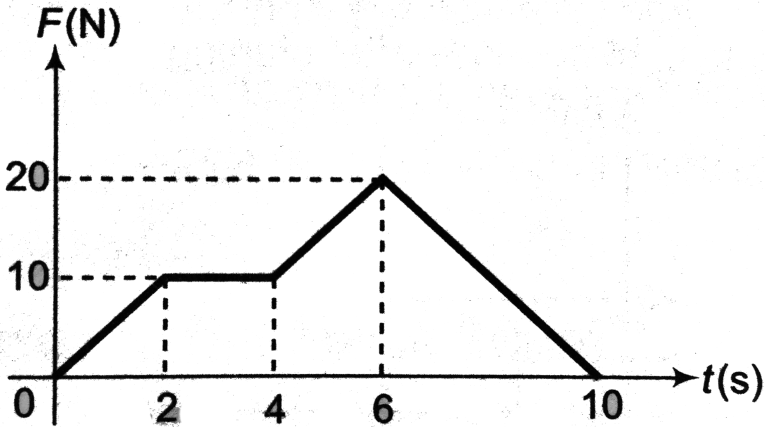

**Fig. 11.29**

- A. 10
- B. 30
- C. 40
- D. 50

**Answer: D**

 [Watch Video Solution](#)

18. A bullet of mass  $10^{-3}kg$  strikes an obstacle and moves at  $60^\circ$  to its original direction. If its speed also changes from  $20m/s$  to  $10m/s$ . Find the magnitude of impulse acting on the bullet.

 [Watch Video Solution](#)

19. Two blocks A and B of equal mass  $m = 1.0kg$  are lying on a smooth horizontal surface as shown in figure. A spring of force constant  $k = 200N/m$  is fixed at one end of block A. Block B collides with block A with velocity  $v_0 = 2.0m/s$ . Find the maximum compression of the spring.



 [Watch Video Solution](#)

20. Two balls of masses  $m$  and  $2m$  moving in opposite directions collide head on elastically with velocities  $v$  and  $2v$ . Find their velocities after collision.



[Watch Video Solution](#)

21. Two pendulum bobs of masses  $m$  and  $2m$  collide head on elastically at the lowest point in their motion. If both the balls are released from a height  $H$  above the lowest point, to what heights do they rise for the first time after collision?



[Watch Video Solution](#)

22. A ball of mass  $m$  moving at a speed  $v$  makes a head on inelastic collision with an identical ball at rest. The kinetic energy of the balls after the collision is  $\frac{3}{4}$ th of the original. Find the coefficient of restitution.

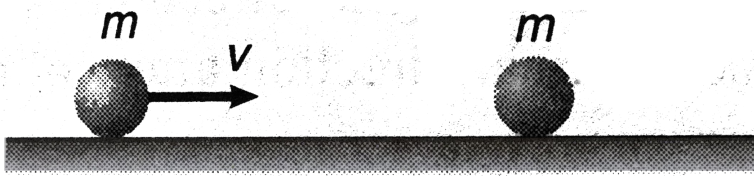

[Watch Video Solution](#)

23. A ball is moving with velocity  $2m/s$  towards a heavy wall moving towards the ball with speed  $1m/s$  as shown in figure. Assuming collision

to be elastic, find the velocity of ball immediately after the collision.

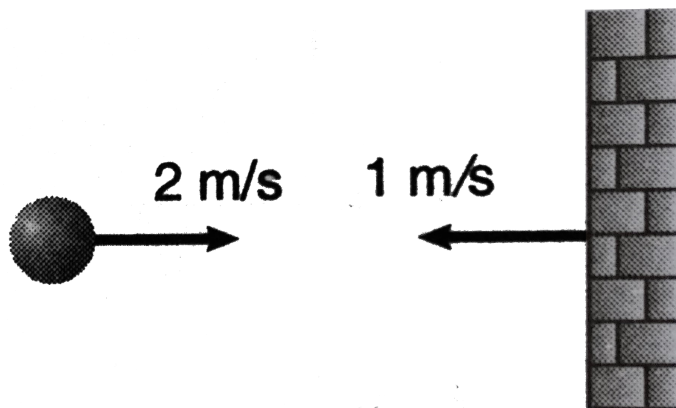

A.  $v = 4m/s$

B.  $v = 3m/s$

C.  $v = 0m/s$

D.  $v = 1m/s$

**Answer: A**



**Watch Video Solution**



24. A ball of mass  $m$  hits a floor with a speed  $v_0$  making an angle of incidence  $\alpha$  with the normal. The coefficient of restitution is  $e$ . Find the speed of the reflected ball and the angle of reflection of the ball.



[Watch Video Solution](#)

25. After a completely inelastic collision two objects of the same mass and same initial speed are found to move away together at half their initial speed. Find the angle between the initial velocities of the objects.

A.  $120^\circ$

B.  $90^\circ$

C.  $180^\circ$

D.  $60^\circ$

**Answer: A**



[Watch Video Solution](#)

26. The coefficient of restitution between a snooker ball and the side cushion is  $\frac{1}{3}$ . If the ball hits the cushion and then rebounds at right angles to its original direction, show that the angles made with the side cushion by the direction of motion before and after impact are  $60^\circ$  and  $30^\circ$  respectively.



[Watch Video Solution](#)

## Solved Examples

1. A trolley of mass  $M$  is at rest over a smooth horizontal surface as shown in figure. Two boys each of mass ' $m$ ' are standing over the trolley. They jump from the trolley (towards right) with relative velocity  $v_r$  [relative to velocity of trolley just after jumping]

(a) together

(b) one after the other.

Find velocity of trolley in both cases.

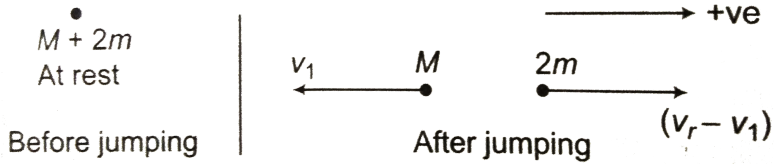

[Watch Video Solution](#)

2. A block of mass  $m$  is placed on a triangular block of mass  $M$  ( $M = 2m$ ), as shown. All surfaces are smooth. Calculate the velocity of triangular block when the smaller block reaches at bottom.

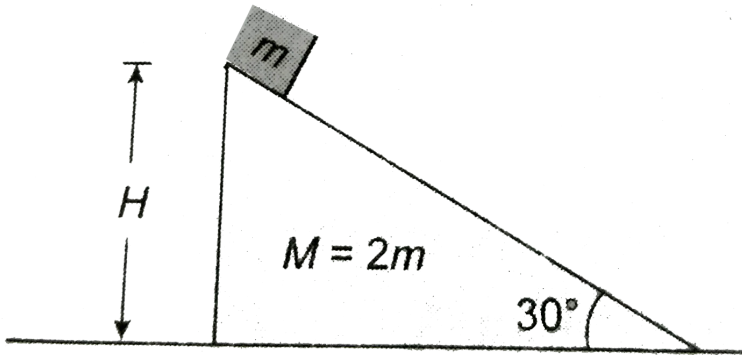

[Watch Video Solution](#)

3. All surfaces shown in figure are smooth. Wedges of mass 'M' is free to move. Block of mass 'm' is given a horizontal velocity  $v_0$  as shown. Find the maximum height 'h' attained by 'm' (over the wedges or outside it).

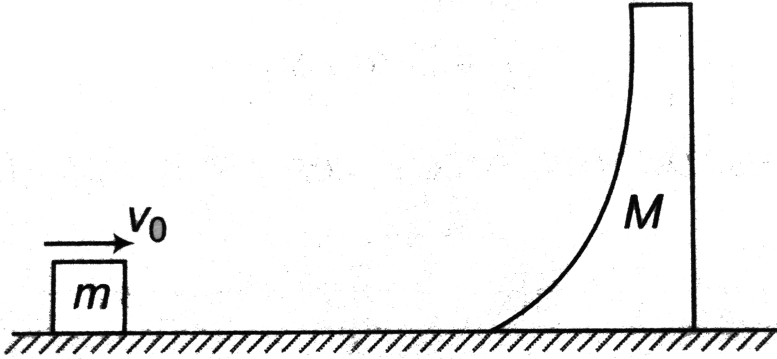

[▶ Watch Video Solution](#)

4. A wooden plank of mass  $20kg$  is resting on a smooth horizontal floor. A man of mass  $60kg$  starts moving from one end of the plank to the other end. The length of the plank is  $10m$ . Find the displacement of the plank

over the floor when the man reaches the other end of the plank.

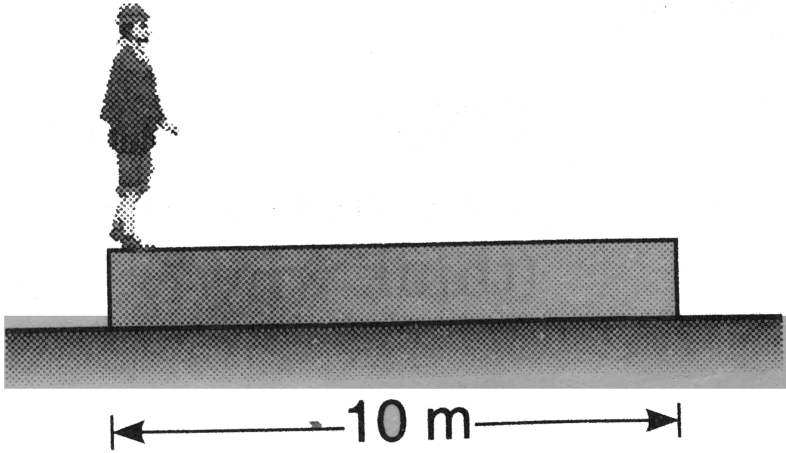

[▶ Watch Video Solution](#)

5. A man of mass  $m_1$  is standing on a platform of mass  $m_2$  kept on a smooth horizontal surface. The man starts moving on the platform with a velocity  $v_r$  relative to the platform. Find the recoil velocity of platform.

[▶ Watch Video Solution](#)

6. A block of mass  $m$  is released from the top of a wedge of mass  $M$  as shown in figure. Find the displacement of wedges on the horizontal ground when the block reaches the bottom of the wedges. Neglect friction everywhere.

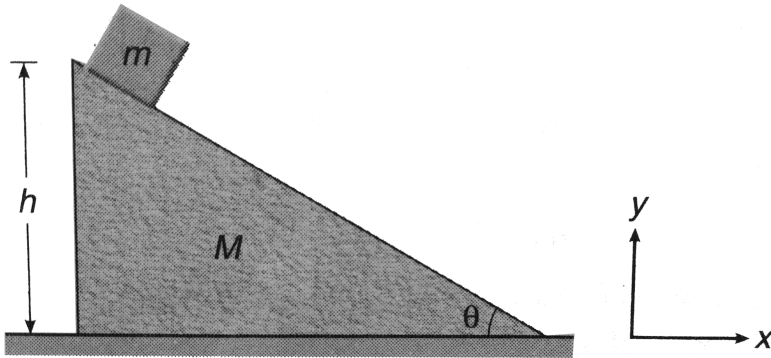

[▶ Watch Video Solution](#)

7. A bomb of mass ' $5m$ ' at rest explodes into three parts of masses  $2m$ ,  $2m$  and  $m$ . After explosion, the equal parts move at right angles with speed  $v$  each. Find speed of the third part and total energy released during explosion.

[▶ Watch Video Solution](#)

8. A projectile of mass  $3\text{kg}$  is projected with velocity  $50\text{m/s}$  at  $37^\circ$  from horizontal. After  $2\text{s}$ , explosion takes place and the projectile breaks into two parts of masses  $1\text{kg}$  and  $2\text{kg}$ . The first part comes to rest just after explosion.

Find,

(a) the velocity of second part just after explosion.

(b) maximum height attained by this part. Take  $g = 10\text{m/s}^2$



[Watch Video Solution](#)

9. A constant force  $F$  is applied on a trolley of initial mass  $m_0$  kept over a smooth surface. Sand is poured gently over the trolley at a constant rate of  $(\mu)\text{kg/s}$ . After time  $t$ , find

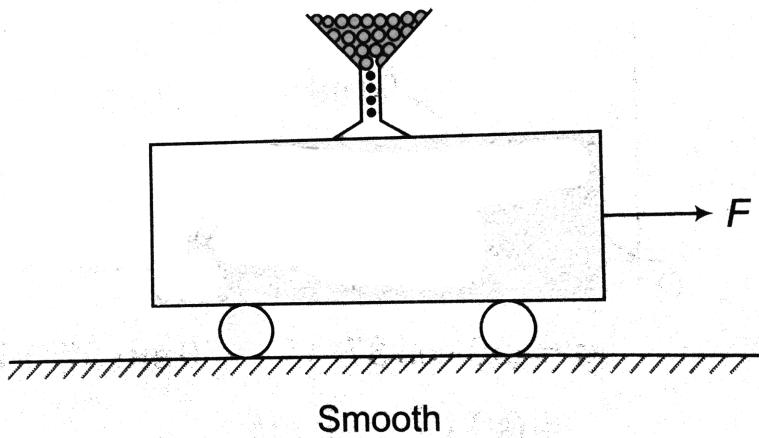

- (a) mass of the trolley (with sand)
- (b) net force on the trolley
- (c) velocity of trolley

[Watch Video Solution](#)

10. A trolley of initial mass  $m_0$  is kept over a smooth surface as shown in figure. A constant force  $F$  is applied on it. Sand kept inside the trolley drains out from its floor at a constant rate of  $(\mu) \text{ kg/s}$ . After time  $t$  find:



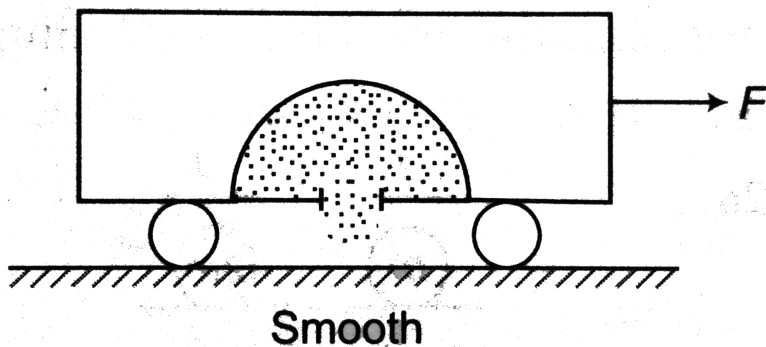

- (a) total mass of trolley and sand.
- (b) net force on the trolley.
- (c) velocity of trolley.

[▶ Watch Video Solution](#)

11. Two balls of masses  $m$  and  $2m$  and momenta  $4p$  and  $2p$  (in the directions shown) collide as shown in figure. During collision, the value of linear impulse between them is  $J$ . In terms of  $J$  and  $p$  find coefficient of restitution 'e'. Under what condition collision is elastic. Also find the

condition of perfectly inelastic collision.

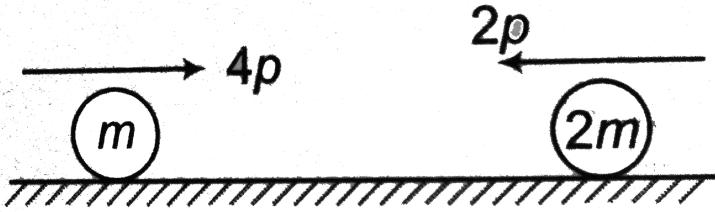

[▶ Watch Video Solution](#)

12. In the situation discussed above, find

- velocity of combined mass just after collision at the bottommost point ( or  $u$ ).
- loss of mechanical energy during collision.
- minimum value of  $v_0$  so that the combined mass completes the vertical circular motion.

[▶ Watch Video Solution](#)

13. A pendulum bob of mass  $10^{-2}kg$  is raised to a height  $5 \times 10^{-2}m$  and then released. At the bottom of its swing, it picks up a mass  $10^{-3}kg$ . To what height will the combined mass rise?



[Watch Video Solution](#)

## Type 1

1. Two toy trains each of mass 'M' are moving in opposite directions with velocities  $v_1$  and  $v_2$  over two smooth rails. Two stuntmen of mass 'm' each are also moving with the trains (at rest w.r.t. trains). When trains are opposite to each other the stuntmen interchange their positions, then find the final velocities of the trains.



[View Text Solution](#)

## Miscellaneous Examples

1. The friction coefficient between the horizontal surface and each of the block shown in the figure is 0.2. The collision between the blocks is perfectly elastic. Find the separation between them when they come to rest. (Take  $g = 10\text{ m/s}^2$ ).

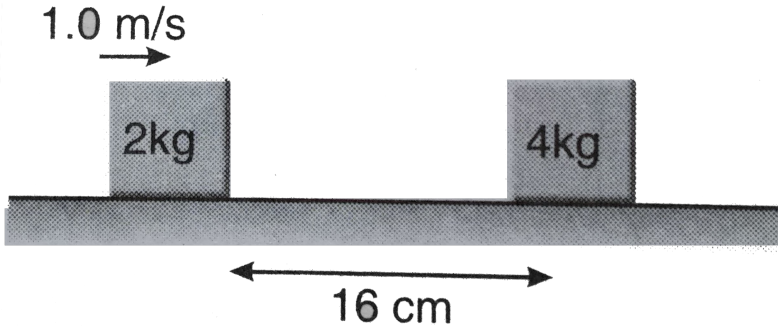

[Watch Video Solution](#)

2. Three identical balls, ball I, ball II and ball III are placed on a smooth floor on a straight line at the separation of  $10\text{ m}$  between balls as shown in figure. Initially balls are stationary. But I is given velocity of  $10\text{ m/s}$  towards ball II, collision between balls I and II is inelastic with coefficient of restitution 0.5 but collision between balls II and III is perfectly elastic. What is the time interval between two consecutive collisions between ball

I and II?

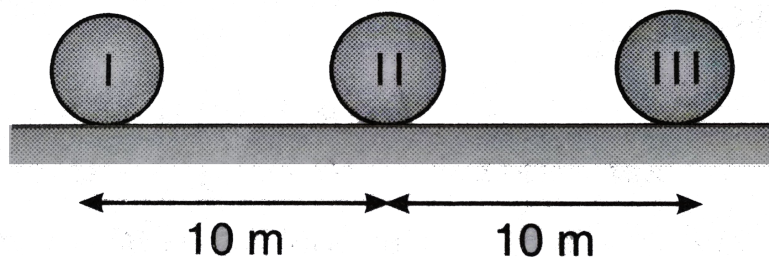

A. 4s

B. 5s

C. 1s

D. 10s

**Answer: A**

 [Watch Video Solution](#)

3. A plank of mass  $5kg$  is placed on a frictionless horizontal plane. Further a block of mass  $1kg$  is placed over the plank. A massless spring of natural length  $2m$  is fixed to the plank by its one end. The other end of spring is compressed by the block by half of spring's natural length. They

system is now released from the rest. What is the velocity of the plank when block leaves the plank? (The stiffness constant of spring is  $100\text{ N/m}$ )

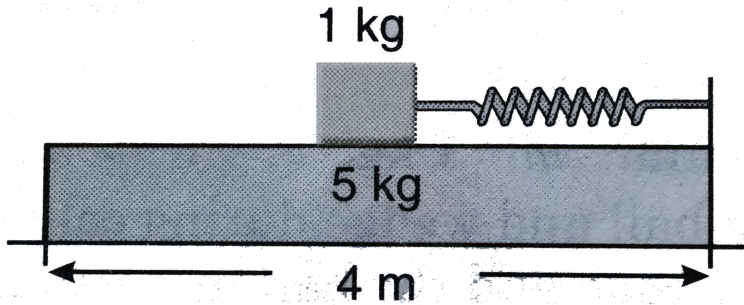

[Watch Video Solution](#)

4. A ball is projected from the ground with speed  $u$  at an angle  $\alpha$  with horizontal. It collides with a wall at a distance  $a$  from the point of projection and returns to its original position. Find the coefficient of restitution between the ball and the wall.

[Watch Video Solution](#)

5. A ball of mass  $m = 1\text{kg}$  falling vertically with a velocity  $v_0 = 2\text{m/s}$  strikes a wedge of mass  $M = 2\text{kg}$  kept on a smooth, horizontal surface as shown in figure. If impulse between ball and wedge during collision is  $J$ . Then make two equations which relate  $J$  with velocity components of wedge and ball. Also find impulse on wedges from ground during impact.

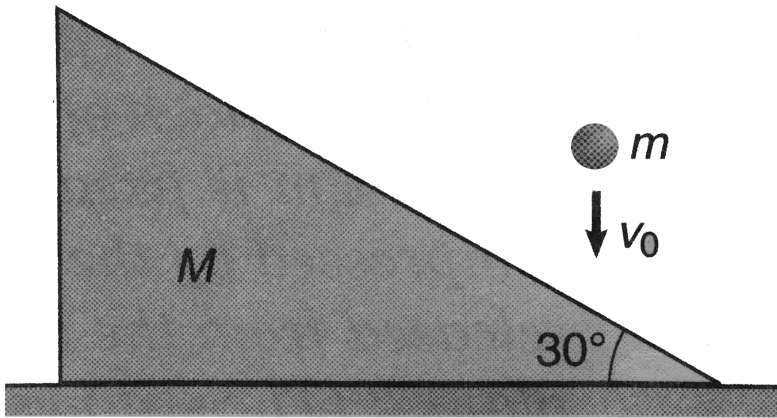

[▶ Watch Video Solution](#)

6. Two blocks of equal mass  $m$  are connected by an unstretched spring and the system is kept at rest on a frictionless horizontal surface. A constant force  $F$  is applied on one of the blocks pulling it away from the other as shown in figure. (a) Find the displacement of the centre of mass

at time  $t$ . (b) If the extension of the spring is  $x_0$  at time  $t$ , find the displacement of the two blocks at this instant.

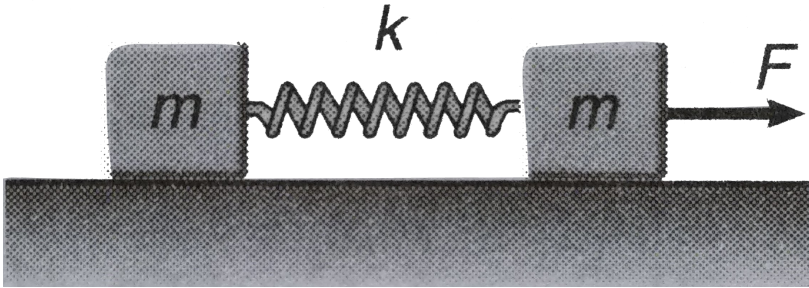

[▶ Watch Video Solution](#)

7. A block of mass  $m$  is connect to another block of mass  $M$  by a massless spring of spring constant  $k$ . The blocks are kept on a smooth horizontal plane. Initially the blocks are at rest and the spring is unstretched when a constant force  $F$  starts acting on the block of mass  $M$  to pull it. Find the maximum extension of the spring.

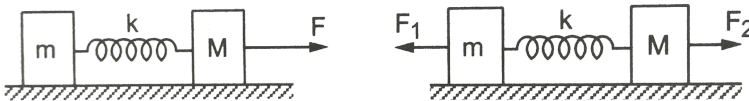

[▶ Watch Video Solution](#)



8. Two blocks A and B of masses  $m$  and  $2m$  respectively are placed on a smooth floor. They are connected by a spring. A third block C of mass  $m$  moves with a velocity  $v_0$  along the line joining A and B and collides elastically with A, as shown in figure. At a certain instant of time  $t_0$  after collision, it is found that the instantaneous velocities of A and B are the same. Further, at this instant the compression of the spring is found to be  $x_0$ . Determine (i) the common velocity of A and B at time  $t_0$ , and (ii) the spring constant.

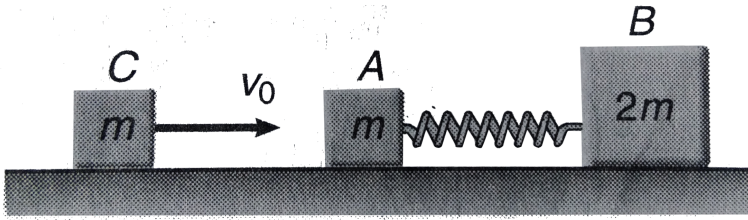

[Watch Video Solution](#)

9. A uniform chain of mass  $m$  and length  $l$  hangs on a thread and touches the surface of a table by its lower end. Thread breaks suddenly. Find the force exerted by the table on the chain when half of its length has fallen

on the table. The fallen part does not form heap

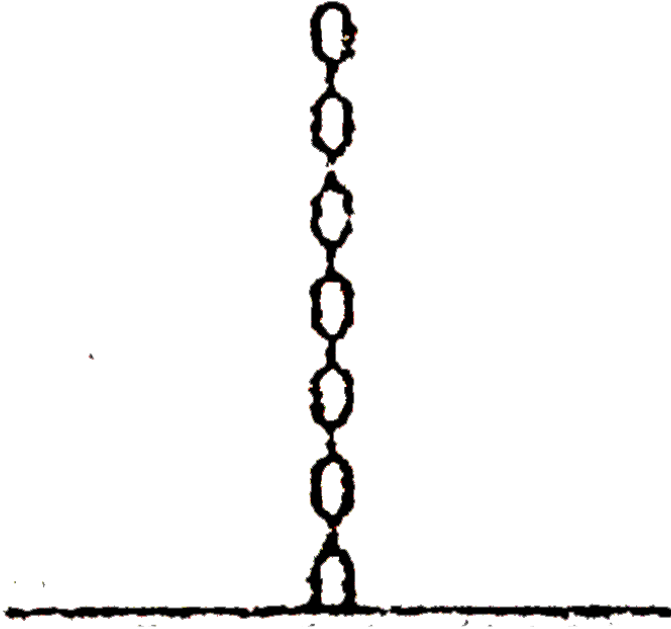

A.  $\frac{3}{2}mg$

B.  $mg$

C. 0

D.  $\frac{5}{2}mg$

**Answer: A**



**Watch Video Solution**

## Exercise 11.1

1. What is the difference between centre of mass and centre of gravity?

 [Watch Video Solution](#)

2. The centre of mass of a rigid body always lies inside the body, Is this statement true or false?

 [Watch Video Solution](#)

3. The centre of mass always lies on the axis of symmetry if it exists. Is this statement true or false?

 [Watch Video Solution](#)

4. If all the particles of a system lie in  $y$ - $z$  plane, the  $x$ -coordinate of the centre of mass will be zero. Is this statement true or false?



[Watch Video Solution](#)

5. What can be said about the centre of mass of a solid hemisphere of radius  $r$  without making any calculation. Will its distance from the centre be more than  $r/2$  or less than  $r/2$ ?



[Watch Video Solution](#)

6. All the particles of body are situated at a distance  $R$  from the origin. The distance of the centre of mass of the body from the origin is also  $R$ . Is this statement true or false?



[Watch Video Solution](#)

7. Three particles of masses  $1kg$ ,  $2kg$  and  $3kg$  are placed at the corners A, B and C respectively of an equilateral triangle ABC of edge  $1m$ . Find the distance of their centre of mass from A.



[Watch Video Solution](#)

8. Find the centre of mass of a uniform plate having semicircular inner and outer boundaries of radii  $R_1$  and  $R_2$ .



[Watch Video Solution](#)

9. Find the position of centre of mass of the section shown in figure

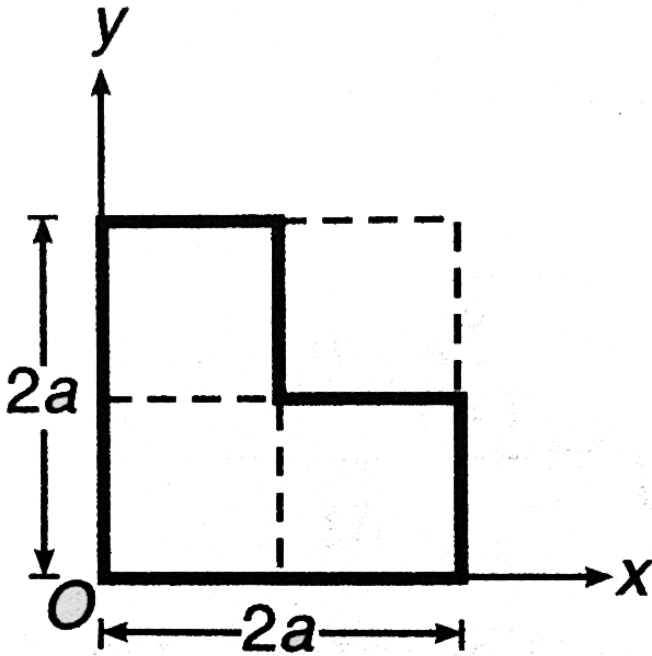

**Fig. 11.14**



[Watch Video Solution](#)

10. Four particles of masses  $1kg$ ,  $2kg$ ,  $3kg$  and  $4kg$  are placed at the four vertices A,B,C and D of a square of side  $1m$ . Find square of distance of their centre of mass from A.



[Watch Video Solution](#)

11. A square lamina of side  $a$  and a circular lamina of diameter  $a$  are placed touching each other as shown in figure. Find distance of their centre of mass from point  $O$ , the centre of square.

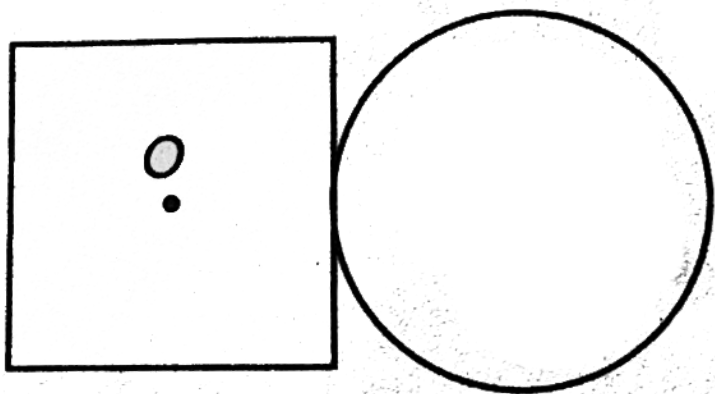

[Watch Video Solution](#)

12. The density of a thin rod of length  $l$  varies with the distance  $x$  from one end as  $\rho = \rho_0 \frac{x^2}{l^2}$ . Find the position of centre of mass of rod.



Watch Video Solution

13. A straight rod of length  $L$  has one of its end at the origin and the other at  $X = L$ . If the mass per unit length of the rod is given by  $Ax$  where  $A$  is constant, where is its centre of mass?



Watch Video Solution

## Exercise 11.2

1. A block of mass  $1kg$  is at  $x = 10m$  and moving towards negative  $x - a\xi s$  with velocity  $6m/s$ . Another block of mass  $2kg$  is at  $x = 12m$  and moving towards positive  $x - axis$  with velocity  $4m/s$  at the same instant. Find position of their centre of mass after  $2s$ .



Watch Video Solution



2. Two particles of masses  $1kg$  and  $2kg$  respectively are initially  $10m$  apart. At time  $t = 0$ , they start moving towards each other with uniform speeds  $2m/s$  and  $1m/s$  respectively. Find the displacement of their centre of mass at  $t = 1s$ .

 [Watch Video Solution](#)

3. There are two masses  $m_1$  and  $m_2$  placed at a distance  $l$  apart. Let the centre of mass of this system is at a point named  $C$ . If  $m_1$  is displaced by  $l_1$  towards  $C$  and  $m_2$  is displaced by  $l_2$  away from  $C$ . Find the distance, from  $C$  where new centre of mass will be located.

 [Watch Video Solution](#)

4. At one instant, the centre of mass of a system of two particles is located on the  $x$ -axis at  $x = 3.0m$  and has a velocity of  $(6.0m/s)\hat{j}$ . One of the particles is at the origin, the other particle has a mass of  $0.10kg$  and is at rest on the  $x$  - axis at  $x = 12.0m$ .

- (a) What is the mass of the particle at the origin?
- (b) Calculate the total momentum of this system.
- (c) What is the velocity of the particle at the origin?



[Watch Video Solution](#)

5. A stone is dropped at  $t = 0$ . A second stone, will twice the mass of the first, is dropped from the same point at  $t = 100ms$ .

- (a) How far below the release point is the centre of mass of the two stones at  $t = 300ms$ ? (Neither stone has yet reached at ground).
- (b) How fast is the centre of the mass of the two-stone system moving at that time?



[Watch Video Solution](#)

6. Two blocks A and B of equal masses are attached to a string passing over a smooth pulley fixed to a wedge as shown in figure. Find the magnitude of acceleration of centre of mass of the two blocks when they

are released from rest. Neglect friction.

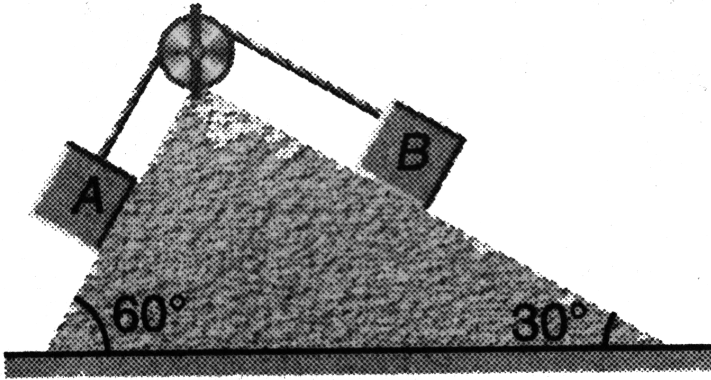

**Fig. 11.23**

[Watch Video Solution](#)

### Exercise 11.3

1. Three particles of masses  $20g$ ,  $30g$  and  $40g$  are initially moving along the positive direction of the three coordinate axes respectively with the same velocity of  $20cm/s$ . When due to their mutual interaction, the first particle comes to rest, the second acquires a velocity  $(10\hat{i} + 20\hat{k})cm/s$ . What is then the velocity of the third particle?

[Watch Video Solution](#)

2. A boy of mass 25 kg stands on a board of mass 10 kg which in turn is kept on a frictionless horizontal ice surface. The boy makes a jump with a velocity component 5 m/s in a horizontal direction with respect to the ice. With what velocity does the board recoil? with what rate are the boy and the board separating from each other?

 [Watch Video Solution](#)

3. Find the ratio of the linear momenta of two particles of masses 1.0 kg and 4.0 kg if their kinetic energies are equal.

 [Watch Video Solution](#)

4. A uranium 238 nucleus, initially at rest emits an alpha particle with a speed of  $1.4 \times 10^7 \frac{m}{s}$ . Calculate the recoil speed of the residual nucleus thorium 234. Assume that the mass of a nucleus is proportional to the mass number.



[Watch Video Solution](#)

5. A man of mass 50 kg starts moving on the earth and acquires speed of 1.8 m/s. With what speed does the earth recoil? Mass of earth =  $6 \times 10^{24} \text{ kg}$ .



[Watch Video Solution](#)

6. A man of mass  $60 \text{ kg}$  jumps from a trolley of mass  $20 \text{ kg}$  standing on smooth surface with absolute velocity  $3 \text{ m/s}$ . Find velocity of trolley and total energy produced by man.



[Watch Video Solution](#)

7. A projectile is fired from a gun at an angle of  $45^\circ$  with the horizontal and with a speed of  $20 \text{ m/s}$  relative to ground. At the highest point in its flight the projectile explodes into two fragments of equal masses. One fragment, whose initial speed is zero falls vertically. How far from the

gun does the other fragment land, assuming a level terrain? Take

$$g = 10m / s^2?$$



[Watch Video Solution](#)

## Exercise 11.4

1. A rocket of mass  $20kg$  has  $180kg$  fuel. The exhaust velocity of the fuel is  $1.6km / s$ . Calculate the minimum rate of consumption of fuel so that the rocket may rise from the ground. Also, calculate the ultimate vertical speed gained by the rocket when the rate of consumption of fuel is

$$(g = 9.8m / s^2)$$

(i)  $2kg / s$  (ii)  $20kg / s$



[Watch Video Solution](#)

2. A rocket, with an initial mass of  $1000kg$ , is launched vertically upwards from rest under gravity. The rocket burns fuel at the rate of  $10kg$  per

second. The burnt matter is ejected vertically downwards with a speed of  $2000\text{ms}^{-1}$  relative to the rocket. If burning ceases after one minute, find the maximum velocity of the rocket. (Take  $g$  as constant at  $10\text{ms}^{-2}$ )

A.  $1232.6\text{m//s}$

B.  $123.6\text{m//s}$

C.  $12323.6\text{m//s}$

D. NONE OF THE ABOVE

**Answer: A**



[Watch Video Solution](#)

3. A rocket is moving vertically upward against gravity. Its mass at time  $t$  is  $m = m_0 - \mu t$  and it expels burnt fuel at a speed  $u$  vertically downward relative to the rocket. Derive the equation of motion of the rocket but do not solve it. Here,  $\mu$  is constant.



[Watch Video Solution](#)

4. A rocket of initial mass  $m_0$  has a mass  $m_0(1 - t/3)$  at time  $t$ . The rocket is launched from rest vertically upwards under gravity and expels burnt fuel at a speed  $u$  relative to the rocket vertically downward. Find the speed of rocket at  $t = 1$ .

 [Watch Video Solution](#)

## Exercise 11.5

1. A truck of mass  $2 \times 10^3 \text{ kg}$  travelling at  $4 \text{ m/s}$  is brought to rest in  $2 \text{ s}$  when it strikes a wall. What force (assume constant) is exerted by the wall?

 [Watch Video Solution](#)

2. A ball of mass  $m$ , travelling with velocity  $2\hat{i} + 3\hat{j}$  receives an impulse  $-3m\hat{i}$ . What is the velocity of the ball immediately afterwards?

 [Watch Video Solution](#)

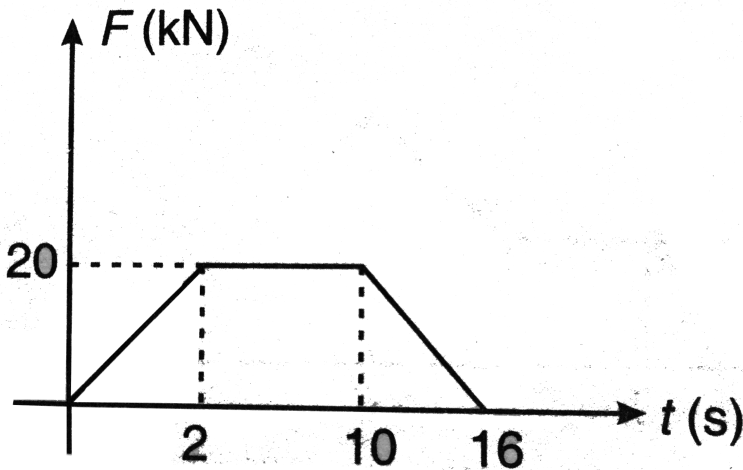

3. The net force versus time graph of a rocket is shown in figure. The mass of the rocket is  $1200\text{kg}$ . Calculate velocity of rocket, 16 seconds after starting from rest. Neglect gravity.

[▶ Watch Video Solution](#)

4. A  $5.0\text{g}$  bullet moving at  $100\text{m/s}$  strikes a log. Assume that the bullet undergoes uniform deceleration and stops in  $6.0\text{cm}$ . Find (a) the time taken for the bullet to stop, (b) the impulse on the log and (c) the average force experienced by the log.

[Watch Video Solution](#)

## Exercise 11.6

1. Two blocks of masses  $3\text{kg}$  and  $6\text{kg}$  respectively are placed on a smooth horizontal surface. They are connected by a light spring of force constant  $k = 200\text{N/m}$ . Initially the spring is unstretched. The indicated velocities are imparted to the blocks. Find the maximum extension of the spring.

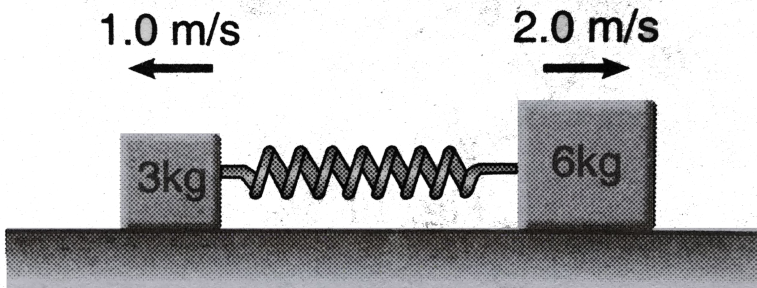

[Watch Video Solution](#)

2. A moving body of mass  $m$  makes a head on elastic collision with another body of mass  $2m$  which is initially at rest. Find the fraction of kinetic energy lost by the colliding particles after collision.

 [Watch Video Solution](#)

3. What is the fractional decrease in kinetic energy of a body of mass  $m_1$  when it makes a head on elastic collision with another body of mass  $m_2$  kept at rest?

 [Watch Video Solution](#)

4. In one dimensional elastic collision of equal masses, the velocities are interchanged. Can velocities in a one dimensional collision be interchanged if the masses are not equal?

 [Watch Video Solution](#)

5. After an head on elastic collision between two balls of equal masses, one is observed to have a speed of  $3m/s$  along the positive x-axis and the other has a speed of  $2m/s$  along the negative x-axis. What are the original velocities of the balls?



[Watch Video Solution](#)

6. A ball of mass  $1kg$  moving with  $4m^{-1}$  along +x-axis collides elastically with an another ball of mass  $2kg$  moving with  $6m/s$  in opposite direction. Find their velocities after collision.



[Watch Video Solution](#)

7. Three balls A, B and C are placed on a smooth horizontal surface. Given that  $m_A = m_C = 4m_B$ . Ball B collides with ball C with an initial velocity  $v$  as shown in figure. Find the total number of collisions between the balls.

All collisions are elastic.

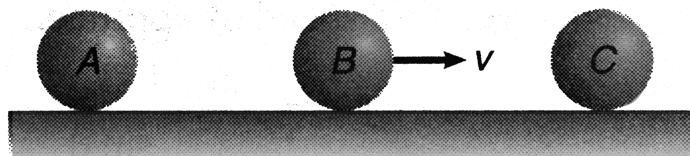

[▶ Watch Video Solution](#)

8. Ball 1 collides directly with another identical ball 2 at rest. Velocity of second ball becomes two times that of 1 after collision. Find the coefficient of restitution between the two balls?

[▶ Watch Video Solution](#)

9. A sphere A of mass  $m$ , travelling with speed  $v$ , collides directly with a stationary sphere B. If A is brought to rest and B is given a speed  $V$ , find (a) the mass of B (b) the coefficient of restitution between A and B?

[▶ Watch Video Solution](#)

10. A smooth sphere is moving on a horizontal surface with velocity vector  $2\hat{i} + 2\hat{j}$  immediately before it hits a vertical wall. The wall is parallel to  $\hat{j}$  and the coefficient of restitution of the sphere and the wall is  $e = \frac{1}{2}$ . Find the velocity of the sphere after it hits the wall?

 [Watch Video Solution](#)

11. A ball falls vertically on an inclined plane of inclination  $\alpha$  with speed  $v_0$  and makes a perfectly elastic collision. What is angle of velocity vector with horizontal after collision.

 [Watch Video Solution](#)

### Level 1 Assertion And Reason

1. Assertion: Centre of mass of a rigid body always lies inside the body.

Reason: Centre of mass and centre of gravity coincide if gravity is uniform.

- A. (a) If both Assertion and Reason are true and the Reason is correct explanation of the Assertion.
- B. (b) If both Assertion and Reason are true but Reason is not the correct explanation of Assertion.
- C. (c) If Assertion is true, but the Reason is false.
- D. (d) If Assertion is false but the Reason is true.

**Answer: D**



**Watch Video Solution**

2. Assertion: A constant force  $F$  is applied on two blocks and one spring system as shown in figure. Velocity of centre of mass increases linearly with time.

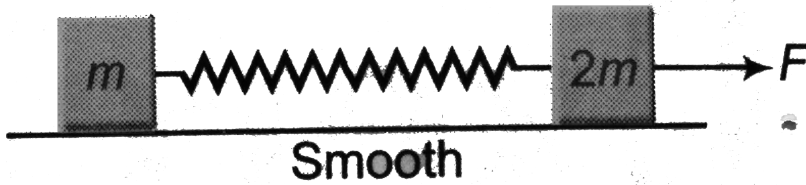

Reason: Acceleration of centre of mass is constant.

- A. (a) If both Assertion and Reason are true and the Reason is correct explanation of the Assertion.
- B. (b) If both Assertion and Reason are true but Reason is not the correct explanation of Assertion.
- C. (c) If Assertion is true, but the Reason is false.
- D. (d) If Assertion is false but the Reason is true.

**Answer: A**



**Watch Video Solution**



**3. Assertion:** To conserve linear momentum of a system, no force should act on the system.

**Reason:** If net force on a system is zero, its linear momentum should remain constant.

- A. If both Assertion and Reason are true and the Reason is correct explanation of the Assertion.
- B. If both Assertion and Reason are true but Reason is not the correct explanation of Assertion.
- C. If Assertion is true, but the Reason is false.
- D. If Assertion is false but the Reason is true.

**Answer: D**



[Watch Video Solution](#)

4. Assertion: A rocket moves forward by pushing the surrounding air backwards.

Reason: It derives the necessary thrust to move forward according to Newton's third law of motion.

A. If both Assertion and Reason are true and the Reason is correct explanation of the Assertion.

B. If both Assertion and Reason are true but Reason is not the correct explanation of Assertion.

C. If Assertion is true, but the Reason is false.

D. If Assertion is false but the Reason is true.

**Answer: D**



**Watch Video Solution**

5. Assertion: Internal forces cannot change linear momentum.

Reason: Internal forces can change the kinetic energy of a system.

- A. (a) If both Assertion and Reason are true and the Reason is correct explanation of the Assertion.
- B. (b) If both Assertion and Reason are true but Reason is not the correct explanation of Assertion.
- C. (c) If Assertion is true, but the Reason is false.
- D. (d) If Assertion is false but the Reason is true.

**Answer: B**



[Watch Video Solution](#)

6. Assertion: In case of bullet fired from gun, the ration of kinetic energy of gun and bullet is equal to ration of mass of bullet and gun.

Reason: Kinetic energy  $\propto \frac{1}{mass}$ , if momentum is constant.

- A. (a) If both Assertion and Reason are true and the Reason is correct explanation of the Assertion.
- B. (b) If both Assertion and Reason are true but Reason is not the correct explanation of Assertion.
- C. (c) If Assertion is true, but the Reason is false.
- D. (d) If Assertion is false but the Reason is true.

**Answer: A**



**Watch Video Solution**

7. Assertion: All surfaces shown in figure are smooth. System is released from rest. Momentum of system in horizontal direction is constant but overall momentum is not constant.

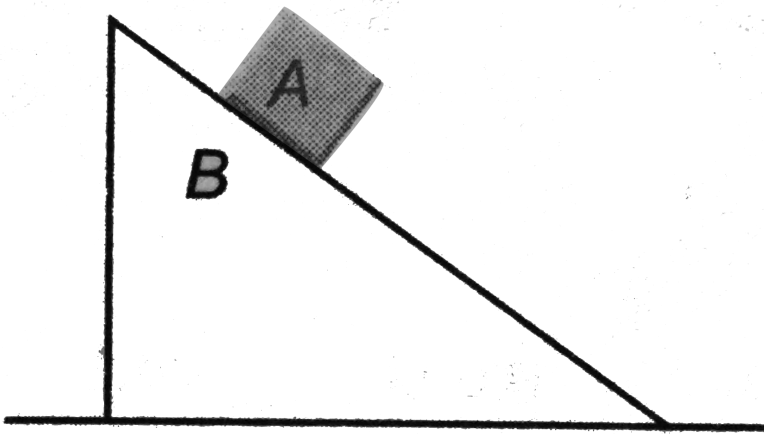

Reason: A net vertically upward force is acting on the system.

- A. (a) If both Assertion and Reason are true and the Reason is correct explanation of the Assertion.
- B. (b) If both Assertion and Reason are true but Reason is not the correct explanation of Assertion.
- C. (c) If Assertion is true, but the Reason is false.
- D. (d) If Assertion is false but the Reason is true.

**Answer: C**

 [Watch Video Solution](#)

8. Assertion: During head on collision between two bodies let  $\Delta p_1$  is change in momentum of first body and  $\Delta p_2$  the change in momentum of the other body, then  $\Delta p_1 = \Delta p_2$ .

Reason: Total momentum of the system should remain constant.

- A. (a) If both Assertion and Reason are true and the Reason is correct explanation of the Assertion.
- B. (b) If both Assertion and Reason are true but Reason is not the correct explanation of Assertion.
- C. (c) If Assertion is true, but the Reason is false.
- D. (d) If Assertion is false but the Reason is true.

**Answer: D**



[Watch Video Solution](#)

9. Assertion: In the system shown in figure spring is first stretched then left to oscillate. At some instant kinetic energy of mass  $m$  is  $K$ . At the same instant kinetic energy of mass  $2m$  should be  $\frac{K}{2}$ .

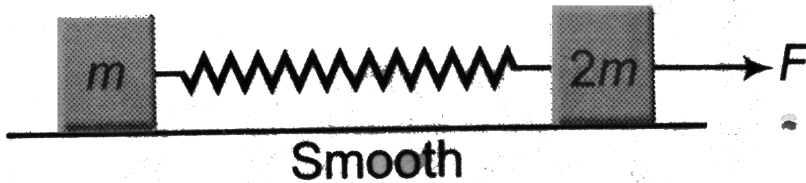

Reason: Their linear momenta are equal and opposite and  $K = \frac{p^2}{2m}$  or  $K = \frac{1}{m}$ .

- A. (a) If both Assertion and Reason are true and the Reason is correct explanation of the Assertion.
- B. (b) If both Assertion and Reason are true but Reason is not the correct explanation of Assertion.
- C. (c) If Assertion is true, but the Reason is false.
- D. (d) If Assertion is false but the Reason is true.

**Answer: A**



[View Text Solution](#)

**10.** Assertion: Energy can not be given to a system without giving it momentum.

Reason: If kinetic energy is given to a body it means it has acquired momentum.

- A. (a) If both Assertion and Reason are true and the Reason is correct explanation of the Assertion.
- B. (b) If both Assertion and Reason are true but Reason is not the correct explanation of Assertion.
- C. (c) If Assertion is true, but the Reason is false.
- D. (d) If Assertion is false but the Reason is true.

**Answer: D**



[Watch Video Solution](#)



11. Assertion: The centre mass of an electron and proton, when released moves faster towards proton.

Reason: Proton is heavier than electron.

A. (a) If both Assertion and Reason are true and the Reason is correct explanation of the Assertion.

B. (b) If both Assertion and Reason are true but Reason is not the correct explanation of Assertion.

C. (c) If Assertion is true, but the Reason is false.

D. (d) If Assertion is false but the Reason is true.

**Answer: D**



[Watch Video Solution](#)

**12. Assertion:** The relative velocity of the two particles in head-on elastic collision is unchanged both in magnitude and direction.

**Reason:** The relative velocity is unchanged in magnitude but gets reversed in direction.

A. (a) If both Assertion and Reason are true and the Reason is correct explanation of the Assertion.

B. (b) If both Assertion and Reason are true but Reason is not the correct explanation of Assertion.

C. (c) If Assertion is true, but the Reason is false.

D. (d) If Assertion is false but the Reason is true.

**Answer: D**



**Watch Video Solution**

**13. Assertion:** An object of mass  $m_1$  and another of mass  $m_2$  ( $m_2 > m_1$ ) are released from certain distance. The objects move towards each other under the gravitational force between them. In this motion, centre of mass of their system will continuously move towards the heavier mass  $m_2$ .

**Reason:** In a system of a heavier and a lighter mass, centre of mass lies closer to the heavier mass.

- A. (a) If both Assertion and Reason are true and the Reason is correct explanation of the Assertion.
- B. (b) If both Assertion and Reason are true but Reason is not the correct explanation of Assertion.
- C. (c) If Assertion is true, but the Reason is false.
- D. (d) If Assertion is false but the Reason is true.

**Answer: D**



**Watch Video Solution**

14. Assertion: A given force applied in turn to a number of different masses may cause the same rate of change in momentum in each but not the same acceleration to all.

Reason:  $F = \frac{dp}{dt}$  and  $a = \frac{F}{m}$

- A. (a) If both Assertion and Reason are true and the Reason is correct explanation of the Assertion.
- B. (b) If both Assertion and Reason are true but Reason is not the correct explanation of Assertion.
- C. (c) If Assertion is true, but the Reason is false.
- D. (d) If Assertion is false but the Reason is true.

**Answer: A**



**Watch Video Solution**

**15. STATEMENT-1 :** In an elastic collision between two bodies, the relative speed of the bodies after collision is equal to the relative speed before the collision.

**STATEMENT-2 :** In an elastic collision, the linear momentum of the system is conserved.

- A. (a) If both Assertion and Reason are true and the Reason is correct explanation of the Assertion.
- B. (b) If both Assertion and Reason are true but Reason is not the correct explanation of Assertion.
- C. (c) If Assertion is true, but the Reason is false.
- D. (d) If Assertion is false but the Reason is true.

**Answer: D**

 [Watch Video Solution](#)

1. A ball is dropped from height 10 m . Ball is embedded in sand 1 m and stops, then

- A. (a) only momentum remains conserved
- B. (b) only kinetic energy remains conserved
- C. (c) both momentum and kinetic energy are conserved
- D. (d) neither kinetic energy nor momentum is conserved

**Answer: A**



[Watch Video Solution](#)

2. If no external force acts on a system

- A. (a) velocity of centre of mass remains constant
- B. (b) position of centre of mass remains constant
- C. (c) acceleration of centre of mass remains non-zero and constant
- D. (d) All of the above

**Answer: A**



[Watch Video Solution](#)

3. When two blocks connected by a spring move towards each other under mutual interaction

- A. (a) their velocities are equal
- B. (b) their accelerations are equal
- C. (c) the force acting on them are equal and opposite
- D. (d) All of the above

**Answer: C**



[Watch Video Solution](#)

4. If two balls collide in air while moving vertically, then momentum of the system is conserved because

- A. gravity does not affect the momentum of the system
- B. force of gravity is very less compared to the impulsive force
- C. impulsive force is very less than the gravity
- D. gravity is not acting during collision

**Answer: B**



**Watch Video Solution**

5. When a cannon shell explodes in mid air, then identify the incorrect statement

- A. (a) the momentum of the system is conserved at the time of explosion
- B. (b) the kinetic energy of the system always increases
- C. (c) the trajectory of centre of mass remains unchanged
- D. (d) None of the above



**Answer: B**



[Watch Video Solution](#)

**6. In an inelastic collision**

- A. (a) momentum of the system is always conserved
- B. (b) velocity of separation is less than the velocity of approach.
- C. (c) the coefficient of restitution can be zero
- D. (d) All of the above

**Answer: D**



[Watch Video Solution](#)

**7. The momentum of a system is defined**

- A. (a) as the product of mass of the system and the velocity of centre of mass
- B. (b) as the vector sum of the momentum of individual particles
- C. (c) for bodies undergoing translational, rotational and oscillatory motion
- D. (d) all the above

**Answer: D**



**Watch Video Solution**

**8. The momentum of a system with respect to centre of mass**

- A. (a) is zero only if the system is moving uniformly
- B. (b) is zero only if no external force acts on the system
- C. (c) is always zero
- D. (d) can be zero in certain conditions

**Answer: C**



[Watch Video Solution](#)

9. Three identical particles are located at the vertices of an equilateral triangle. Each particle moves along a meridian with equal speed towards the centroid and collides inelastically.

- A. (a) all the three particles will bounce back along the meridians with lesser speed.
- B. (b) all the three particles will become stationary.
- C. (c) all the particles will continue to move in their original directions but with lesser speed
- D. (d) nothing can be said

**Answer: D**



[Watch Video Solution](#)

10. The average resisting force that must act on  $5\text{kg}$  mass to reduce its speed from  $65$  to  $15\text{m.s}^{-1}$  in  $2\text{s}$  is

- A.  $12.5\text{N}$
- B.  $125\text{N}$
- C.  $1250\text{N}$
- D. None of these

**Answer: B**



[Watch Video Solution](#)

11. In a carbon monoxide molecule, the carbon and the oxygen atoms are separated by a distance  $1.2 \times 10^{-10}\text{m}$ . The distance of the centre of mass from the carbon atom is

- A.  $0.48 \times 10^{-10}\text{m}$
- B.  $0.51 \times 10^{-10}\text{m}$

C.  $0.74 \times 10^{-10} m$

D.  $0.68 \times 10^{-10} m$

**Answer: D**



**Watch Video Solution**

12. A bomb of mass  $9kg$  explodes into two pieces of masses  $3kg$  and  $6kg$ .

The velocity of mass  $3kg$  is  $16ms^{-1}$ . The kinetic energy of mass  $6kg$  is

A.  $96J$

B.  $384J$

C.  $192J$

D.  $768J$

**Answer: C**



**Watch Video Solution**

13. A heavy ball moving with speed  $v$  collides with a tiny ball. The collision is elastic, then immediately after the impact, the second ball will move with a speed approximately equal to

A. (a)  $v$

B. (b)  $2v$

C. (c)  $\frac{v}{2}$

D. (d)  $\frac{v}{3}$

**Answer: B**



**Watch Video Solution**

14. A loaded  $20,000\text{kg}$  coal wagon is moving on a level track at  $6\text{ms}^{-1}$ . Suddenly  $5000\text{kg}$  of coal is dropped out of the wagon. The final speed of the wagon is

A.  $6\text{ms}^{-1}$

B.  $8ms^{-1}$

C.  $4.8ms^{-1}$

D.  $4.5ms^{-1}$

**Answer: A**



**Watch Video Solution**

15. A machine gun fires a bullet of mass 40 g with a velocity  $1200ms^{-1}$ .

The man holding it can exert a maximum force of 144 N on the gun. How many bullets can be fire per second at the most?

A. (a) 3

B. (b) 5

C. (c) 6

D. (d) 9

**Answer: A**

16. A projectile of mass  $m$  is fired with a velocity  $v$  from point P at an angle  $45^\circ$ . Neglecting air resistance, the magnitude of the change in momentum leaving the point P and arriving at Q is

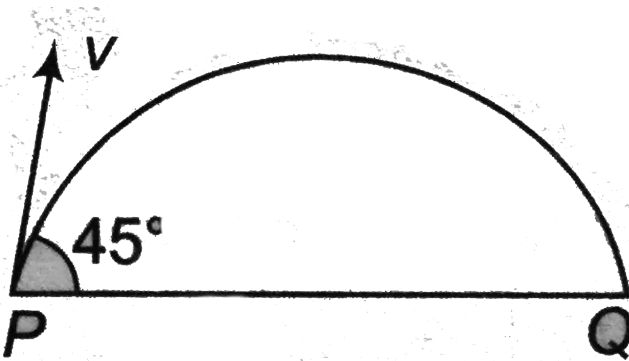

A. (a)  $\sqrt{2}mv$

B. (b)  $2mv$

C. (c)  $\frac{mv}{2}$

D. (d)  $\frac{mv}{\sqrt{2}}$

Answer: A



17. A ball after freely falling from a height of  $4.9m$  strikes a horizontal plane. If the coefficient of restitution is  $\frac{3}{4}$ , the ball will strike second time with the plane after

A.  $\frac{1}{2}s$

B.  $1s$

C.  $\frac{3}{2}s$

D.  $\frac{3}{4}s$

**Answer: C**



**Watch Video Solution**

18. The centre of mass of a non uniform rod of length  $L$ , whose mass per unit length varies as  $\rho = \frac{k \cdot x^2}{L}$  where  $k$  is a constant and  $x$  is the distance of any point from one end is (from the same end)

A.  $\left(\frac{3}{4}\right)L$

B.  $\left(\frac{1}{4}\right)L$

C.  $\left(\frac{1}{6}\right)L$

D.  $\left(\frac{2}{3}\right)L$

**Answer: A**



**Watch Video Solution**

**19.** A boat of length  $10m$  and mass  $450kg$  is floating without motion in still water. A man of mass  $50kg$  standing at one end of it walks to the other end of it and stops. The magnitude of the displacement of the boat in metres relative to ground is

A. (a) zero

B. (b)  $1m$

C. (c)  $2m$

D. (d)  $5m$

**Answer: B**



**Watch Video Solution**

20. A man of mass  $M$  stands at one end of a stationary plank of length  $L$ , lying on a smooth surface. The man walks to the other end of the plank. If the mass of the plank is  $M/3$ , the distance that the man moves relative to the ground is

A.  $\frac{3L}{4}$

B.  $\frac{L}{4}$

C.  $\frac{4L}{5}$

D.  $\frac{L}{3}$

**Answer: B**



**Watch Video Solution**

21. A ball of mass  $m$  moving at a speed  $v$  collides with another ball of mass  $3m$  at rest. The lighter block comes to rest after collision. The coefficient of restitution is

A. (a)  $\frac{1}{2}$

B. (b)  $\frac{2}{3}$

C. (c)  $\frac{1}{4}$

D. (d) None of these

**Answer: D**



[Watch Video Solution](#)

22. A particle of mass  $m$  moving with velocity  $u$  makes an elastic one-dimensional collision with a stationary particle of mass  $m$ . They come in contact for a very small time  $t_0$ . Their force of interaction increases from zero to  $F_0$  linearly in time  $0.5t_0$ , and decreases linearly to zero in further

time  $0.5t_0$  as shown in figure. The magnitude of  $F_0$  is

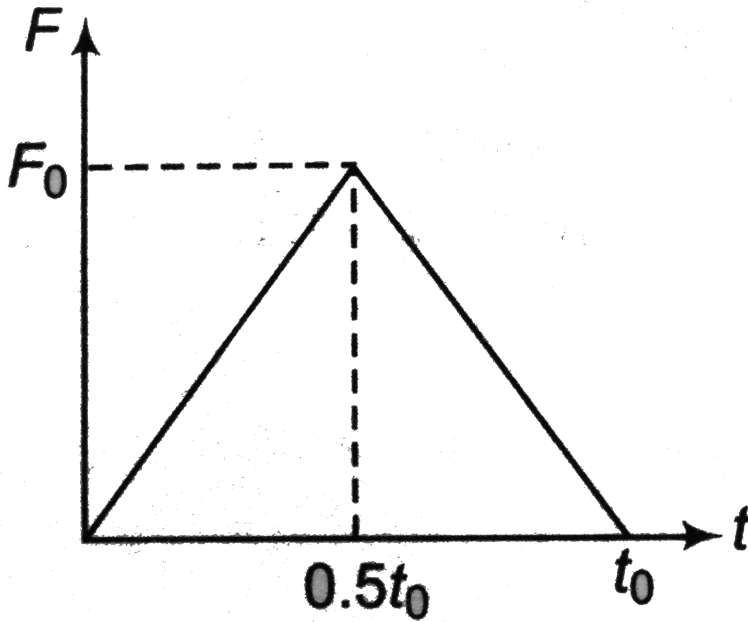

A.  $\frac{\mu}{t_0}$

B.  $\frac{2\mu}{t_0}$

C.  $\frac{\mu}{2t_0}$

D. None of these

**Answer: B**



[Watch Video Solution](#)

23. Two identical blocks A and B of mass  $m$  joined together with a massless spring as shown in figure are placed on a smooth surface. If the block A moves with an acceleration  $a_0$ , then the acceleration of the block B is

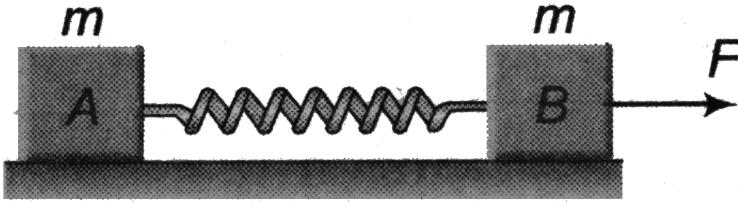

- A.  $a_0$
- B.  $-a_0$
- C.  $\frac{F}{m} - a_0$
- D.  $\frac{F}{m}$

**Answer: C**



**Watch Video Solution**

24. A ball of mass  $m$  moving with velocity  $v_0$  collides a wall as shown in figure. After impact it rebounds with a velocity  $\frac{3}{4}v_0$ . The impulse acting on ball during impact is

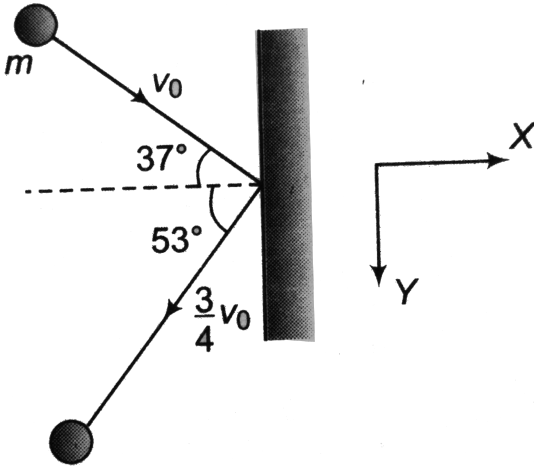

- A.  $-\frac{m}{2}v_0\hat{j}$
- B.  $-\frac{3}{4}mv_0\hat{i}$
- C.  $-\frac{5}{4}mv_0\hat{i}$

D. None of the above

Answer: C

 Watch Video Solution

25. A steel ball is dropped on a hard surface from a height of  $1\text{m}$  and rebounds to a height of  $64\text{cm}$ . The maximum height attained by the ball after  $n^{\text{th}}$  bounce is (in m)

A. (a)  $(0.64)^{2n}$

B. (b)  $(0.8)^{2n}$

C. (c)  $(0.5)^{2n}$

D. (d)  $(0.8)^n$

**Answer: B**



**Watch Video Solution**

26. A car of mass  $500\text{kg}$  (including the mass of a block) is moving on a smooth road with velocity  $1.0\text{ms}^{-1}$  along positive x-axis. Now a block of mass  $25\text{kg}$  is thrown outside with absolute velocity of  $20\text{ms}^{-1}$  along



positive z-axis. The new velocity of the car is ( $m s^{-1}$ )

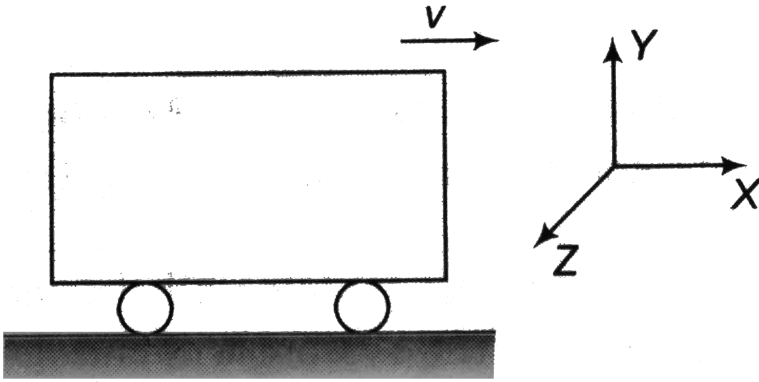

A. (a)  $10\hat{i} + 20\hat{k}$

B. (b)  $10\hat{i} - 20\hat{k}$

C. (c)  $\frac{20}{19}\hat{i} - \frac{20}{19}\hat{k}$

D. (d)  $10\hat{i} - \frac{20}{19}\hat{k}$

**Answer: C**





**Watch Video Solution**

27. The net force acting on a particle moving along a straight line varies with time as shown in the diagram. Force is parallel to velocity. Which of

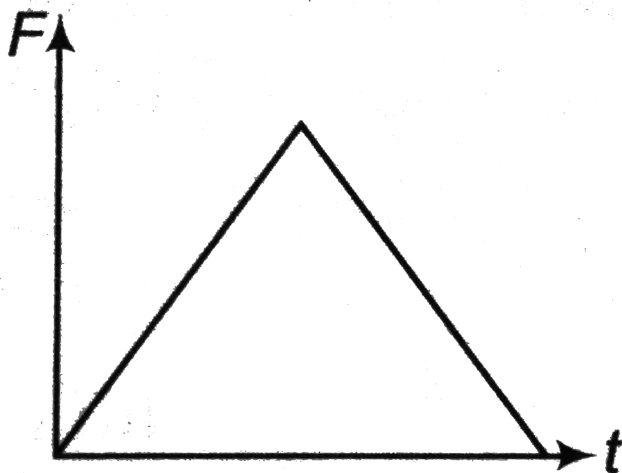
the following graph is best representative of its speed with time? (Initial velocity of the particle is zero)



A. (a) 

B. (b) 

C. (c) 

D. (d) 

**Answer: A**



**Watch Video Solution**

28. In the figure shown, find out centre of mass of a system of a uniform circular plate of radius  $3R$  from O in which a hole of radius  $R$  is cut whose centre is at  $2R$  distance from the centre of large circular plate

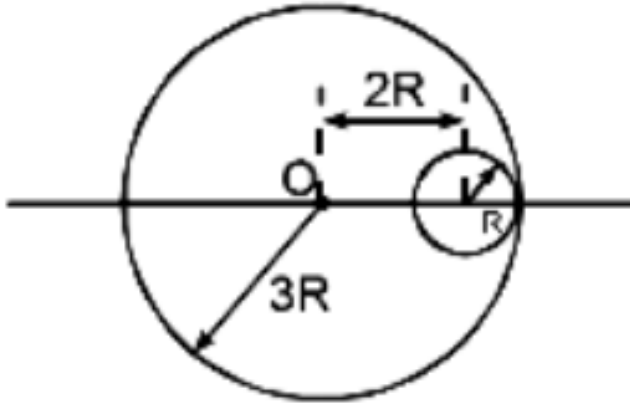

A. (a)  $\frac{R}{2}$

B. (b)  $\frac{R}{5}$

C. (c)  $\frac{R}{4}$

D. (d) None of these

Answer: C



Watch Video Solution

29. From the circular disc of radius  $4R$  two small discs of radius  $R$  are cut off. The centre of mass of the new structure will be at

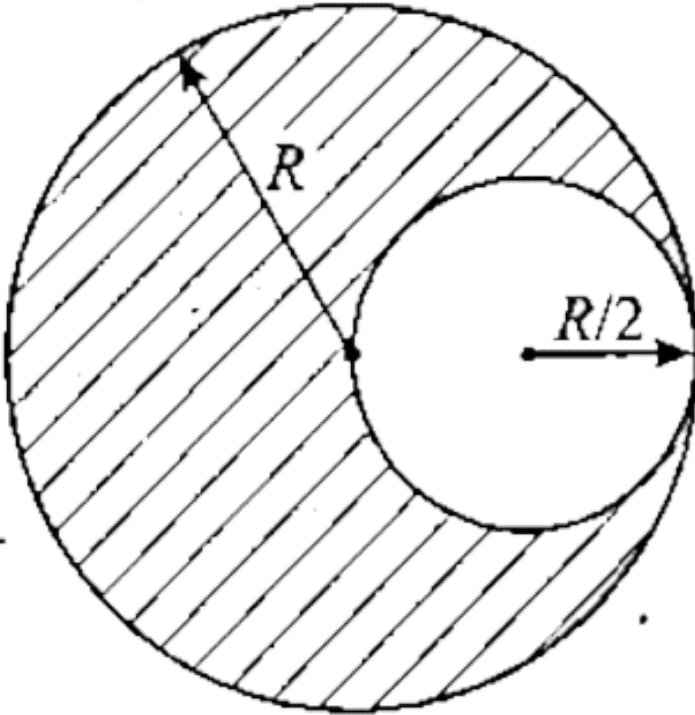

A.  $\hat{i} \frac{R}{5} + \hat{j} \frac{R}{5}$

B. (b)  $-\hat{i} \frac{R}{5} + \hat{j} \frac{R}{5}$

C. (c)  $-\hat{i} \frac{R}{5} - \hat{j} \frac{R}{5}$

D. (d) None of the above

**Answer: D**



[Watch Video Solution](#)

**30.** A block of mass  $m$  rests on a stationary wedge of mass  $M$ . The wedge can slide freely on a smooth horizontal surface as shown in figure. If the block starts from rest



- A. (a) the position of the centre of mass of the system will change
- B. (b) the position of centre of mass of the system will change along the vertical but not along the horizontal
- C. (c) the total energy of the system will remain constant
- D. (d) All of the above

**Answer: D**



[Watch Video Solution](#)

31. A bullet of mass  $m$  hits a target of mass  $M$  hanging by a string and gets embedded in it. If the block rises to a height  $h$  as a result of this collision, the velocity of the bullet before collision is

A.  $v = \sqrt{2gh}$

B.  $v = \sqrt{2gh} \left[ 1 + \frac{m}{M} \right]$

C.  $v = \sqrt{2gh} \left[ 1 + \frac{M}{m} \right]$

D.  $v = \sqrt{2gh} \left[ 1 - \frac{m}{M} \right]$

**Answer: C**



**Watch Video Solution**

32. A loaded spring gun of mass  $M$  fires a bullet of mass  $m$  with a velocity  $v$  at an angle of elevation  $\theta$ . The gun is initially at rest on a horizontal smooth surface. After firing, the centre of mass of the gun and bullet system

A. (a) moves with velocity  $\frac{v}{M}m$

B. (b) moves with velocity  $\frac{vm}{m \cos \theta}$  in the horizontal direction

C. (c) does not move in horizontal direction

D. (d) moves with velocity  $\frac{v(M - m)}{M + m}$  in the horizontal direction

**Answer: C**

 [Watch Video Solution](#)

**33.** Two bodies with masses  $m_1$  and  $m_2$  ( $m_1 > m_2$ ) are joined by a string passing over fixed pulley. Assume masses of the pulley and thread negligible. Then the acceleration of the centre of mass of the system ( $m_1 + m_2$ ) is

A. (a)  $\left(\frac{m_1 - m_2}{m_1 + m_2}\right)g$

B. (b)  $\left(\frac{m_1 - m_2}{m_1 + m_2}\right)^2 g$

C. (c)  $\frac{m_1 g}{m_1 + m_2}$

D. (d)  $\frac{m_2 g}{m_1 + m_2}$

**Answer: B**



[Watch Video Solution](#)

**34.** A rocket of mass  $m_0$  has attained a speed equal to its exhaust speed and that time the mass of the rocket is  $m$ . Then the ratio  $\frac{m_0}{m}$  is (neglect gravity)

A. (a) 2.718

B. (b) 7.8

C. (c) 3.14

D. (d) 4

**Answer: A**



[Watch Video Solution](#)



35. A jet of water hits a flat stationary plate perpendicular to its motion. The jet ejects  $500\text{g}$  of water per second with a speed of  $1\text{m/s}$ . Assuming that after striking, the water flows parallel to the plate, then the force exerted on the plate is

- A. (a)  $5\text{N}$
- B. (b)  $1.0\text{N}$
- C. (c)  $0.5\text{N}$
- D. (d)  $10\text{N}$

**Answer: C**



[Watch Video Solution](#)

36. Two identical vehicles are moving with same velocity  $v$  towards an intersection as shown in figure. If the collision is completely inelastic, then



A. (a) the velocity of separation is zero

B. (b) the velocity of approach is  $2v\sin\frac{\theta}{2}$

C. (c) the common velocity after collision is  $v\cos\frac{\theta}{2}$

D. (d) All of the above

**Answer: D**



**Watch Video Solution**

37. A ball of mass  $m = 1\text{kg}$  strikes a smooth horizontal floor as shown in figure. The impulse exerted on the floor is



A. (a)  $6.25\text{Ns}$

B. (b)  $1.76\text{Ns}$

C. (c)  $7.8\text{Ns}$

D. (d)  $2.2\text{Ns}$

Answer: A

 Watch Video Solution

38. A small block of mass  $m$  is placed at rest on the top of a smooth wedge of mass  $M$ , which in turn is placed at rest on a smooth horizontal surface as shown in figure. Let  $h$  be the height of wedge and  $\theta$  is the inclination, then the distance moved by the wedge as the block reaches the foot of the wedge is

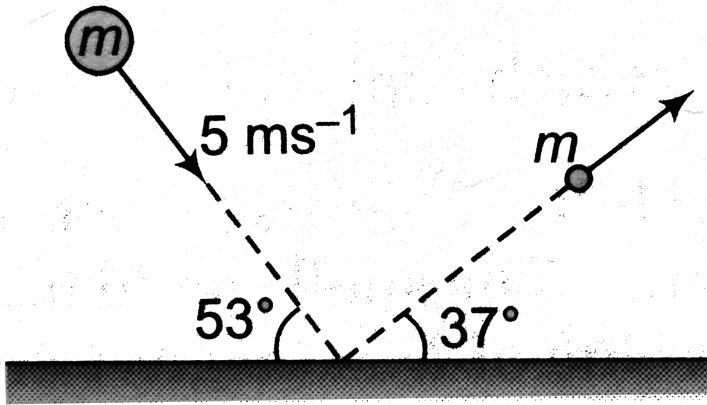

A.  $\frac{Mh \cot \theta}{M + m}$

B. (b)  $\frac{mh \cot \theta}{M + m}$

C. (c)  $\frac{Mh \cos e\theta}{M + m}$

D. (d)  $\frac{mh \cos e\theta}{M + m}$

**Answer: B**



**Watch Video Solution**

**39.** A square of side  $2cm$  and uniform thickness is divided into four squares. The square portion  $A'AB'D$  is removed and the removed portion is placed over the portion  $DB'BC'$ . The new position of centre

of mass is

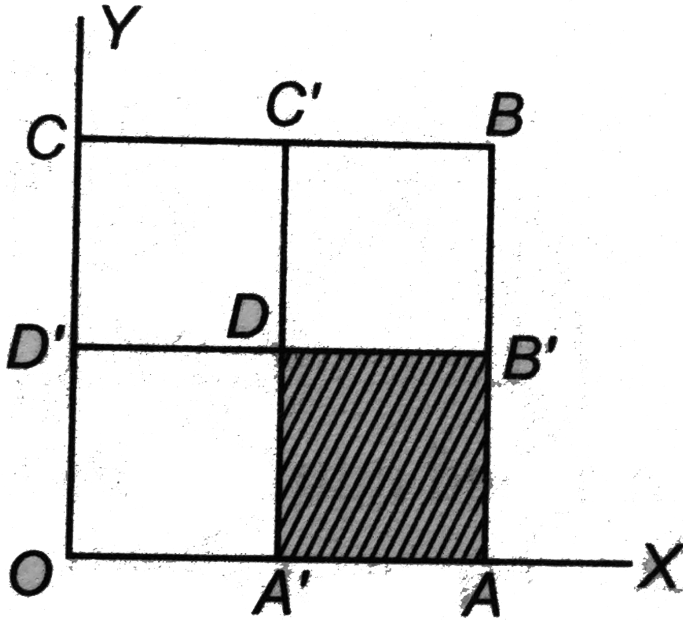

- A.  $(2\text{cm}, 2\text{cm})$
- B.  $(2\text{cm}, 3\text{cm})$
- C.  $(2\text{cm}, 2.5\text{cm})$
- D.  $(3\text{cm}, 3\text{cm})$

Answer: C

 [Watch Video Solution](#)

40. A boy having a mass of  $40\text{kg}$  stands at one end A of a boat of length  $2\text{m}$  at rest. The boy walks to the other end B of the boat and stops. What is the distance moved by the boat? Friction exists between the feet of the boy and the surface of the boat. But the friction between the boat and the water surface may be neglected. Mass of the boat is  $15\text{kg}$ .

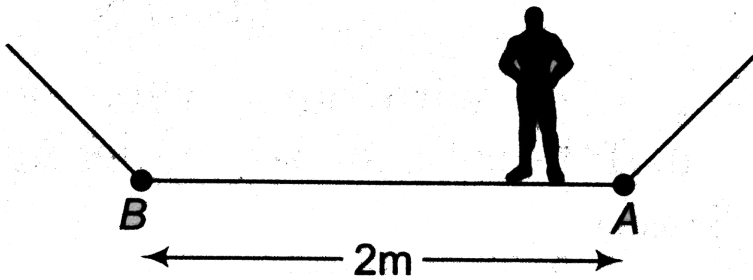

- A. (a)  $0.49\text{m}$
- B. (b)  $2.46\text{m}$
- C. (c)  $1.46\text{m}$
- D. (d)  $3.2\text{m}$

**Answer: C**



**Watch Video Solution**

41. Three identical particles with velocities  $v_0\hat{i}$ ,  $-3v_0\hat{j}$  and  $5v_0\hat{k}$  collide successively with each other in such a way that they form a single particle. The velocity vector of resultant particle is

A. (a)  $\frac{v_0}{3}(\hat{i} + \hat{j} + \hat{k})$

B. (b)  $\frac{v_0}{3}(\hat{i} - \hat{j} + \hat{k})$

C. (c)  $\frac{v_0}{3}(\hat{i} - 3\hat{j} + \hat{k})$

D. (d)  $\frac{v_0}{3}(\hat{i} - 3\hat{j} + 5\hat{k})$

**Answer: D**



**Watch Video Solution**

42. A mortar fires a shell of mass  $M$  which explodes into two pieces of mass  $\frac{M}{5}$  and  $\frac{4M}{5}$  at the top of the trajectory. The smaller mass falls very close to the mortar. In the same time bigger piece lands a distance  $D$

from the mortar. The shell would have fallen at a distance  $R$  from the mortar if there was no explosion. The value of  $D$  is (neglect air resistance)

A.  $\frac{3R}{2}$

B.  $\frac{4R}{3}$

C.  $\frac{5R}{4}$

D. None of these

**Answer: C**



[Watch Video Solution](#)

## Level 1 Subjective

1. Consider a rectangular plate of dimensions  $a \times b$ . If this plate is considered to be made up of four rectangles of dimensions  $\frac{a}{2} \times \frac{b}{2}$  and we now remove one out of four rectangles. Find the position where the



centre of mass of the remaining system will lie?

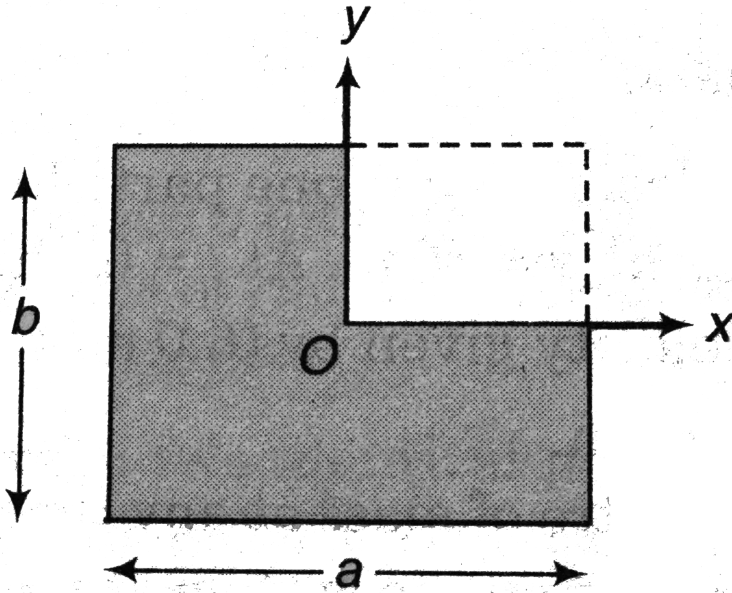

[Watch Video Solution](#)

2. The uniform solid sphere shown in the figure has a spherical hole in it.

Find the position of its centre of mass.

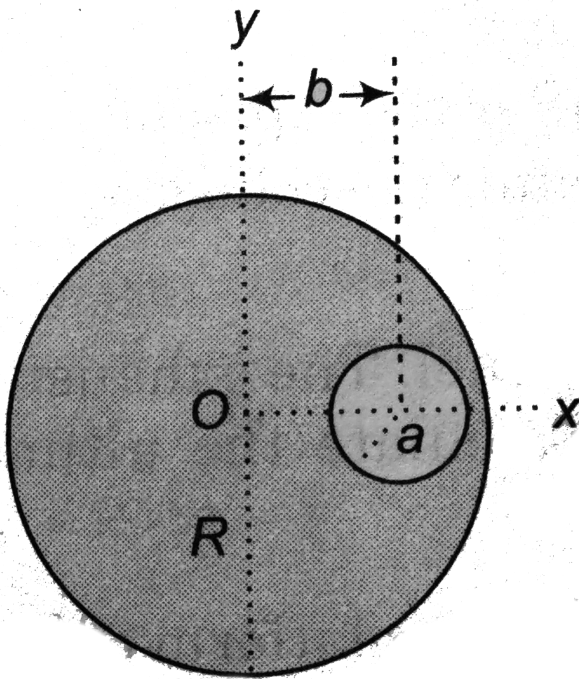

[Watch Video Solution](#)

3. A gun fires a bullet. The barrel of the gun is inclined at an angle of  $45^\circ$  with horizontal. When the bullet leaves the barrel it will be travelling at an angle greater than  $45^\circ$  with the horizontal. Is this statement true or false?



[Watch Video Solution](#)

4. Two blocks A and B of masses  $m_A$  and  $m_B$  are connected together by means of a spring and are resting on a horizontal frictionless table. The blocks are then pulled apart so as to stretch the spring and then released. Show that the kinetic energies of the blocks are, at any instant inversely proportional to their masses.

 [Watch Video Solution](#)

5. Show that in a head on elastic collision between two particles, the transference of energy is maximum when their mass ratio is unity.

 [Watch Video Solution](#)

6. A particle moving with kinetic energy  $K$  makes a head on elastic collision with an identical particle at rest. Find the maximum elastic potential energy of the system during collision.

 [Watch Video Solution](#)

7. A ball is projected from the ground at some angle with horizontal. Coefficient of restitution between the ball and the ground is  $e$ . Let  $a$ ,  $b$  and  $c$  be the ratio of times of flight, horizontal range and maximum height in two successive paths. Find  $a$ ,  $b$  and  $c$  in terms of  $e$ .

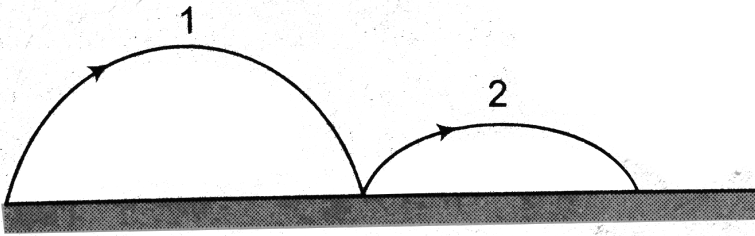

[Watch Video Solution](#)

8.  $x - y$  is the vertical plane as shown in figure. A particle of mass  $1\text{kg}$  is at  $(10\text{m}, 20\text{m})$  at time  $t = 0$ . It is released from rest. Another particles of mass  $2\text{kg}$  is at  $(20\text{m}, 40\text{m})$  at the same instant. It is projected with

velocity  $(10\hat{i} + 10\hat{j})\text{ m/s}$ . After 1s. Find

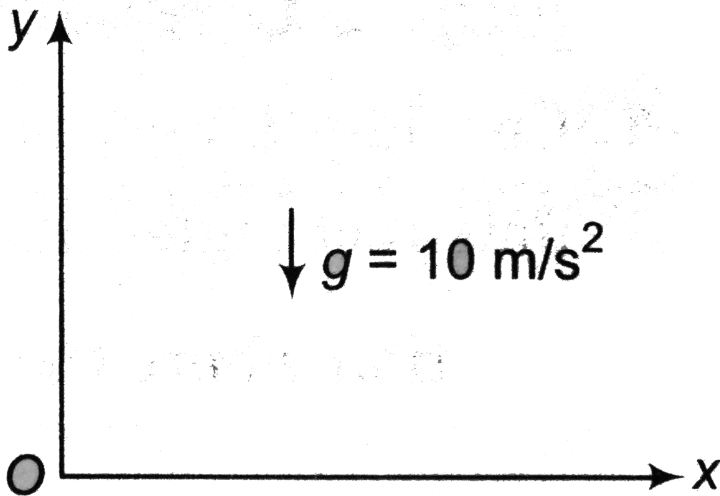

[Watch Video Solution](#)

9. A system consists of two particles. At  $t = 0$ , one particle is at the origin, the other, which has a mass of  $0.60\text{ kg}$ , is on the  $y$ -axis at  $y = 80\text{ m}$ . At  $t = 0$ , the centre of mass of the system is on the  $y$ -axis at  $y = 24\text{ m}$  and has a velocity given by  $(6.0\text{ m/s}^3)t^2\hat{j}$ .

- Find the total mass of the system.
- Find the acceleration of the centre of mass at any time  $t$ .
- Find the next external force acting on the system at  $t = 3.0\text{ s}$ .

[Watch Video Solution](#)

10. A particle of mass  $2\text{kg}$  moving with a velocity  $5\hat{i}\text{m/s}$  collides head-on with another particle of mass  $3\text{kg}$  moving with a velocity  $-2\hat{i}\text{m/s}$ . After the collision the first particle has speed of  $1.6\text{m/s}$  in negative  $x$ -direction, Find

- (a) velocity of the centre of mass after the collision,
- (b) velocity of the second particle after the collision.
- (c) coefficient of restitution.



Watch Video Solution

11. A rocket of mass  $40\text{kg}$  has  $160\text{kg}$  fuel. The exhaust velocity of the fuel is  $2.0\text{km/s}$ . The rate of consumption of fuel is  $4\text{kg/s}$ . Calculate the ultimate vertical speed gained by the rocket. ( $g = 10\text{m/s}^2$ )

A.  $2\text{km/s}$

B.  $2.82\text{km/s}$

C.  $1\text{km/s}$

D.  $10\text{km/s}$

**Answer: B**

 [Watch Video Solution](#)

12. A boy of mass  $60\text{kg}$  is standing over a platform of mass  $40\text{kg}$  placed over a smooth horizontal surface. He throws a stone of mass  $1\text{kg}$  with velocity  $v = 10\text{m/s}$  at an angle of  $45^\circ$  with respect to the ground. Find the displacement of the platform (with boy) on the horizontal surface when the stone lands on the ground. Take  $g = 10\text{m/s}^2$ .

 [Watch Video Solution](#)

13. A man of mass  $m$  climbs to a rope ladder suspended below a balloon of mass  $M$ . The balloon is stationary with respect to the ground.

(a) If the man begins to climb the ladder at speed  $v$  (with respect to the

ladder), in what direction and with what speed (with respect to the ground) will the balloon move?

(b) What is the state of the motion after the man stops climbing?

 [Watch Video Solution](#)

14. Find the mass of the rocket as a function of time, if it moves with a constant acceleration  $a$ , in absence of external forces. The gas escapes with a constant velocity  $u$  relative to the rocket and its mass initially was  $m_0$ .

 [Watch Video Solution](#)

15. A particle of mass  $2m$  is projected at an angle of  $45^\circ$  with horizontal with a velocity of  $20\sqrt{2}m/s$ . After  $1s$  explosion takes place and the particle is broken into two equal pieces. As a result of explosion one part comes to rest. Find the maximum height attained by the other part. Take  $g = 10m/s^2$ .

 [Watch Video Solution](#)



16. A ball of mass  $1\text{kg}$  is attached to an inextensible string. The ball is released from the position shown in figure. Find the impulse imparted by the string to the ball immediately after the string becomes taut. (Take  $g = 10\text{m/s}^2$ )

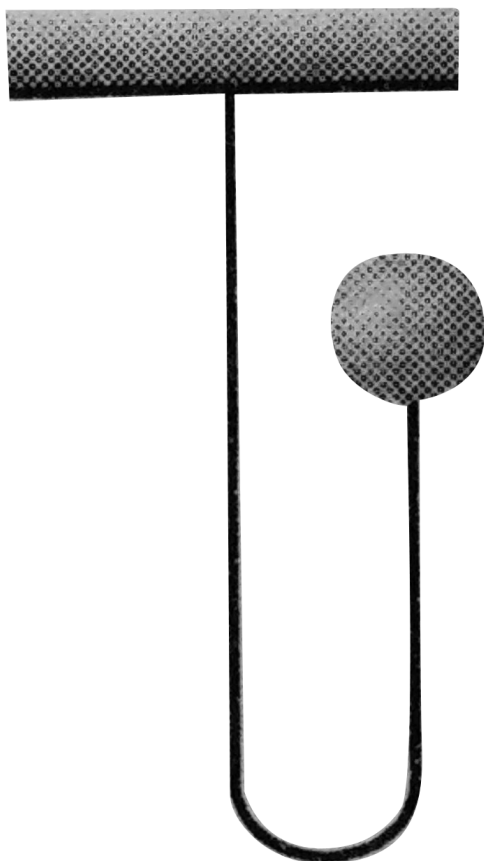

[▶ Watch Video Solution](#)

17. The two balls shown in figure are identical the first moving at a speed  $v$  towards right and the second staying at rest. The wall at the extreme right is fixed. Assume all collisions to be elastic. Show that the speeds of the balls remain unchanged after all the collisions have taken place.

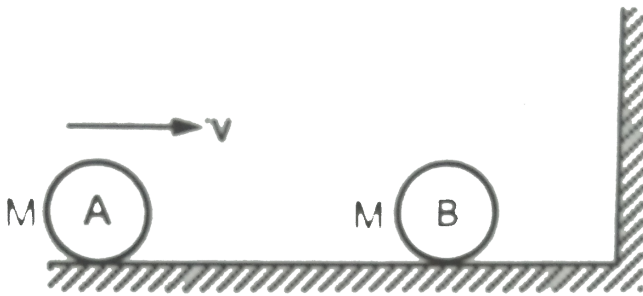

[▶ Watch Video Solution](#)

18. A particle of mass 100 g moving at an initial speed  $u$  collides with another particle of same mass kept initially at rest. If the total kinetic energy becomes 0.2 J after the collision what could be minimum and the maximum value of  $u$ .

 [Watch Video Solution](#)

19. A particle of mass  $m$  moving with a speed  $v$  hits elastically another stationary particle of mass  $2m$  on a smooth horizontal circular tube of radius  $r$ . Find the time when the next collision will take place?

 [Watch Video Solution](#)

20. In a one-dimensional collision between two identical particles. A and B, B is stationary and A has momentum  $p$  before impact. During impact, B gives an impulse  $J$  to A. Find the coefficient of restitution between A and B?

 [Watch Video Solution](#)

21. Two billiard balls of same size and mass are in contact on a billiard table. A third ball of same mass and size strikes them symmetrically and

remains at rest after the impact. Find the coefficient of restitution between the balls?

[▶ Watch Video Solution](#)

22. Two identical blocks each of mass  $M = 9\text{kg}$  are placed on a rough horizontal surface of frictional coefficient  $\mu = 0.1$ . The two blocks are joined by a light spring and block B is in contact with a vertical fixed wall as shown in figure. A bullet of mass  $m = 1\text{kg}$  and  $v_0 = 10\text{m/s}$  hits block A and gets embedded in it. Find the maximum compression of spring. (Spring constant  $= 240\text{N/m}$ ,  $g = 10\text{m/s}^2$ )

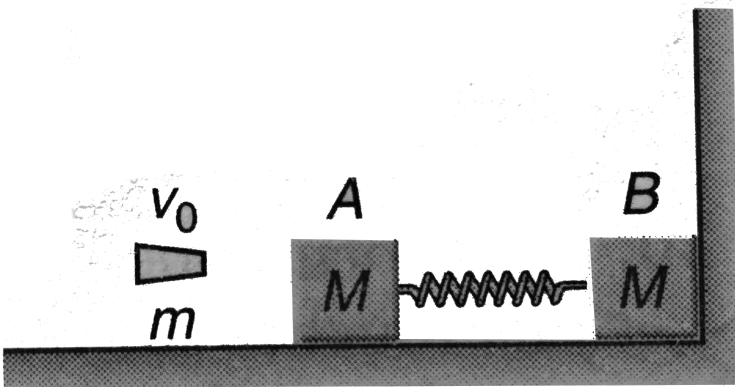

[▶ Watch Video Solution](#)

23. Block A has a mass of  $5\text{kg}$  and is placed on top of a smooth triangular block, B having a mass of  $30\text{kg}$ . If the system is released from rest, determine the distance, B moves when A reaches the bottom. Neglect the size of block A.

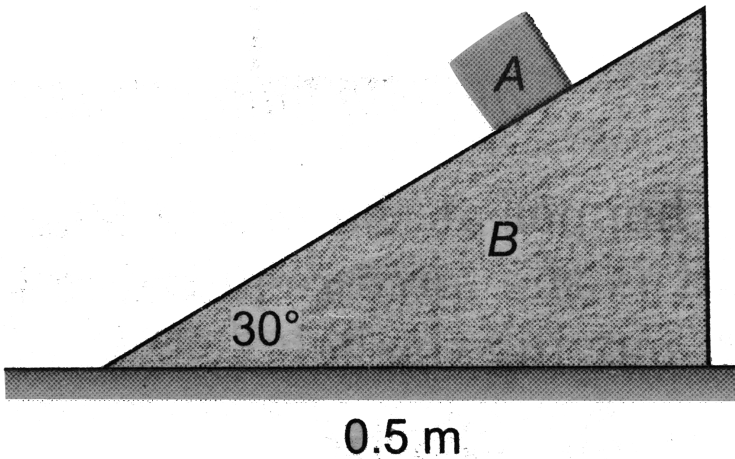

[▶ Watch Video Solution](#)

24. A trolley was moving horizontally on a smooth ground with velocity  $v$  with respect to the earth. Suddenly a man starts running from rear end of the trolley with a velocity  $(3/2)v$  with respect to the trolley. After

reaching the other end, the man turns back and continues running with a velocity  $(3/2)v$  with respect to trolley in opposite direction. If the length of the trolley is  $L$ , find the displacement of the man with respect to earth when he reaches the starting point on the trolley. Mass of the trolley is equal to the mass of the man.

 [Watch Video Solution](#)

**25.** A  $4.00g$  bullet travelling horizontally with a velocity of magnitude  $500m/s$  is fired into a wooden block with a mass of  $1.00kg$ , initially at rest on a level surface. The bullet passes through the block and emerges with speed  $100m/s$ . The block slides a distance of  $0.30m$  along the surface from its initial position.

- (a) What is the coefficient of kinetic friction between block and surface?
- (b) What is the decrease in kinetic energy of the bullet?
- (c) What is the kinetic energy of the block at the instant after the bullet has passed through it? Neglect friction during collision of bullet with the block.

 [Watch Video Solution](#)

**26.** A wagon of mass  $M$  can move without friction along horizontal rails. A simple pendulum consisting of a sphere of mass  $m$  is suspended from the ceiling of the wagon by a string of length  $l$ . At the initial moment the wagon and the pendulum are at rest and the string is deflected through an angle  $\alpha$  from the vertical. Find the velocity of the wagon when the pendulum passes through its mean position.



**Watch Video Solution**

**27.** A block of mass  $M$  with a semicircular of radius  $R$ , rests on a horizontal frictionless surface. A uniform cylinder of radius  $r$  and mass  $m$  is released from rest the top point A. The cylinder slips on the semicircular frictionless track. How far has the block moved when the cylinder reaches the bottom (point B) of the track? How fast is the block moving when the

cylinder reaches the bottom of the track?

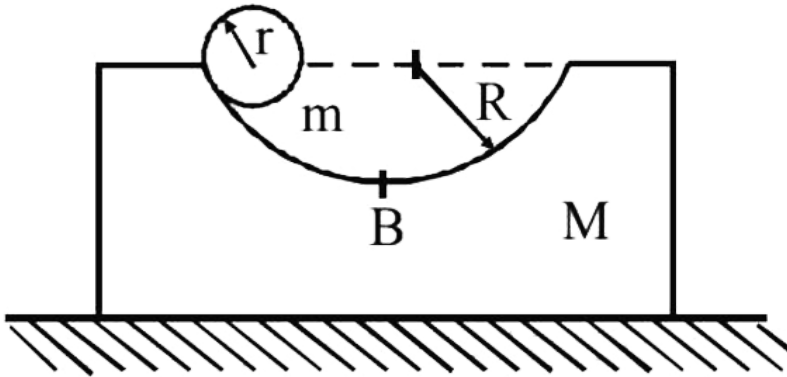

[▶ Watch Video Solution](#)

28. A ball of mass 50 g moving at a speed of 2.0 m/s strikes a plane surface at an angle of incidence  $45^\circ$ . The ball is reflected by the plane at an equal angle of reflection with the same speed. Calculate (a). the magnitude of the change in momentum of the ball (b). the change in the magnitude of the momentum of the ball.

[▶ Watch Video Solution](#)



29. A uniform rope of mass  $m$  per unit length, hangs vertically from a support so that the lower end just touches the table top shown in figure. If it is released, show that at the time a length  $y$  of the rope has fallen, the force on the table is equivalent to the weight of the length  $3y$  of the rope.

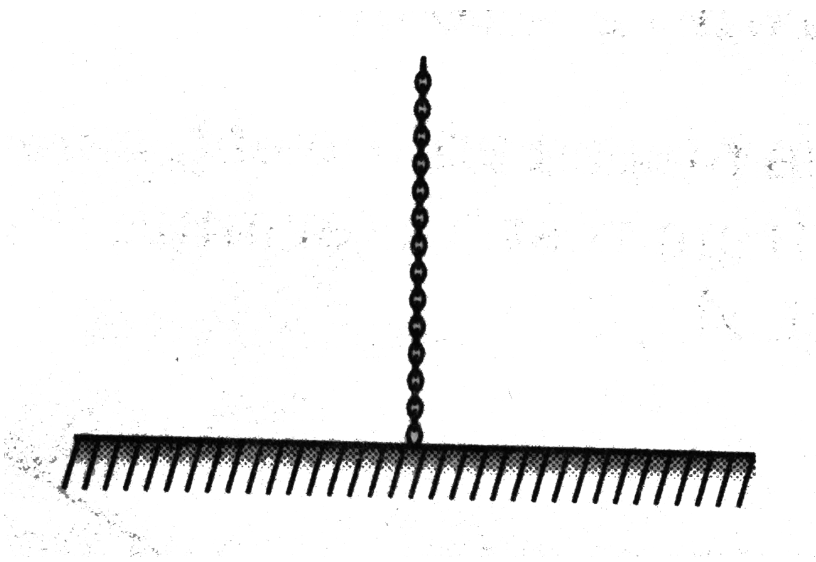

Watch Video Solution

30. Sand drops from a stationary hopper at the rate of  $5kg/s$  on to a conveyor belt moving with a constant speed of  $2m/s$ . What is the force

required to keep the belt moving and what is the power delivered by the motor, moving the belt?

 [Watch Video Solution](#)

**31.** A  $3.0\text{kg}$  block slides on a frictionless horizontal surface, first moving to the left at  $50\text{m/s}$ . It collides with a spring as it moves left, compresses the spring and is brought to rest momentarily. The body continues to be accelerated to the right by the force of compressed spring. Finally, the body moves to the right at  $40\text{m/s}$ . The block remains in contact with the spring for  $0.020\text{s}$ . What were the magnitude and direction of the impulse of the spring on the block? What was the spring's average force on the block?

 [Watch Video Solution](#)

**32.** Block A has a mass  $3\text{kg}$  and is sliding on a rough horizontal surface with a velocity  $u_A = 2\text{m/s}$  when it makes a direct collision with block B, which has a mass of  $2\text{kg}$  and is originally at rest. The collision is perfectly

elastic. Determine the velocity of each block just after collision and the distance between the blocks when they stop sliding. The coefficient of kinetic friction between the blocks and the plane is  $\mu_k = 0.3$  ( Take  $g = 10m/s^2$ )

 [Watch Video Solution](#)

### Level 1 Subjective Questions

1. A bullet of mass  $0.25kg$  is fired with velocity  $302m/s$  into a block of wood of mass  $m_1 = 37.5kg$ . It gets embedded into it. The block  $m_1$  is resting on a long block  $m_2$  and the horizontal surface on which it is placed is smooth. The coefficient of friction between  $m_1$  and  $m_2$  is  $0.5$ . Find the displacement of  $m_1$  on  $m_2$  and the common velocity of  $m_1$  and  $m_2$ . Mass  $m_2 = 1.25kg$ .

 [View Text Solution](#)

### Level 2 Single Correct

1. A pendulum consists of a wooden bob of mass  $m$  and length  $l$ . A bullet of mass  $m_1$  is fired towards the pendulum with a speed  $v_1$  and it emerges from the bob with speed  $\frac{v_1}{3}$ . The bob just completes motion along a vertical circle. Then  $v_1$  is

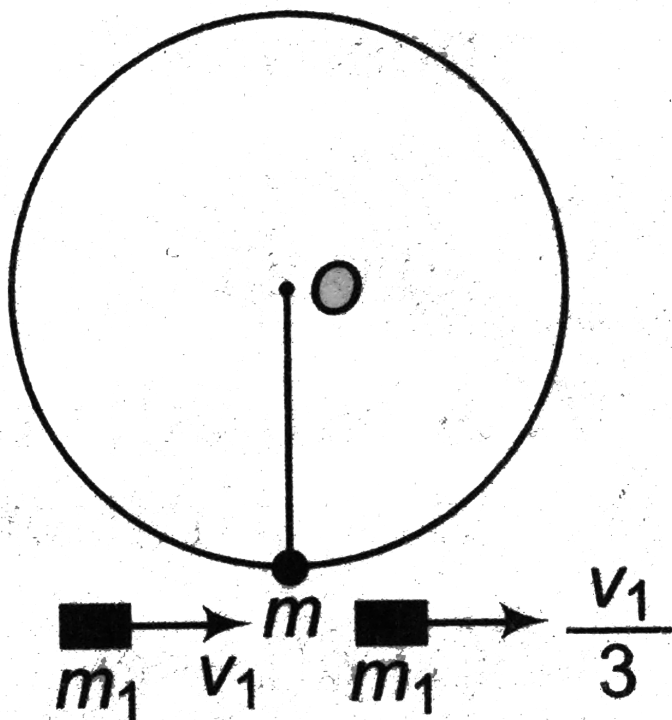

A. (a)  $\frac{m}{m_1} \sqrt{5gl}$

B. (b)  $\frac{3m}{2m_1} \sqrt{5gl}$

C. (c)  $\frac{2}{3} \left( \frac{m}{m_1} \right) \sqrt{5gl}$

D. (d)  $\left( \frac{m_1}{m} \right) \sqrt{gl}$

**Answer: B**



**Watch Video Solution**

2. A bob of mass  $m$  attached with a string of length  $l$  tied to a point on ceiling is released from a position when its string is horizontal. At the bottom most point of its motion, an identical mass  $m$  gently stuck to it. Find the maximum angle from the vertical to which it rotates.

A. (a)  $\cos^{-1} \left( \frac{2}{3} \right)$

B. (b)  $\cos^{-1} \left( \frac{3}{4} \right)$

C. (c)  $\cos^{-1} \left( \frac{1}{4} \right)$

D. (d)  $60^\circ$

**Answer: B**



**Watch Video Solution**

3. A train of mass  $M$  is moving on a circular track of radius  $R$  with constant speed  $v$ . The length of the train is half of the perimeter of the track. The linear momentum of the train will be

A. (a) zero

B. (b)  $\frac{2Mv}{\pi}$

C. (c)  $MvR$

D. (d)  $Mv$

**Answer: B**



**Watch Video Solution**

4. Two blocks A and B of mass  $m$  and  $2m$  are connected together by a light spring of stiffness  $k$ . The system is lying on a smooth horizontal surface with block A in contact with a fixed vertical wall as shown in the figure. The block B is pressed towards the wall by a distance  $x_0$  and then released. There is not friction anywhere. If spring takes time  $\Delta t$  to acquire its natural length then average force on the block A by the wall is



A. (a) zero

B. (b)  $\frac{\sqrt{2mk}}{\Delta t} x_0$

C. (c)  $\frac{\sqrt{mk}}{\Delta t} x_0$

D. (d)  $\frac{\sqrt{3mk}}{\Delta t} x_0$

**Answer: B**



**Watch Video Solution**

5. A striker is shot from a point A exactly at midpoint of one of the walls with a speed of  $2\text{ms}^{-1}$  at an angle of  $45^\circ$  with the x-axis as shown in the figure. The collisions of the striker with the walls of the fixed carom are perfectly elastic. The coefficient of kinetic friction between the striker and board is 0.2. The coordinate of the striker when it stops (taking point O to be origin) is (in SI units)

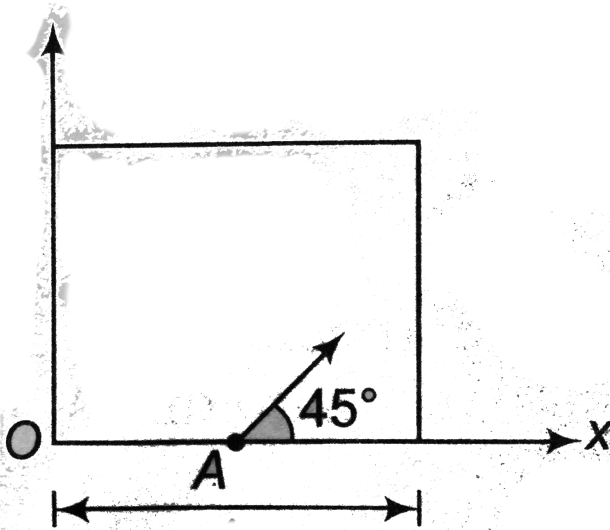

A. (a)  $\frac{1}{2\sqrt{2}}, \frac{1}{\sqrt{2}}$

B. (b)  $0, \frac{1}{2\sqrt{2}}$

C. (c)  $\frac{1}{2\sqrt{2}}, 0$



D. (d)  $\frac{1}{\sqrt{2}}, \frac{1}{2\sqrt{2}}$

**Answer: A**

 [Watch Video Solution](#)

**6.** A ball of mass  $1\text{kg}$  is suspended by an inextensible string  $1\text{m}$  long attached to a point O of a smooth horizontal bar resting on fixed smooth supports A and B. The ball is released from rest from the position when the string makes an angle  $30^\circ$  with the vertical. The mass of the bar is  $4\text{kg}$ . The displacement of bar when ball reaches the other extreme

position (in m) is

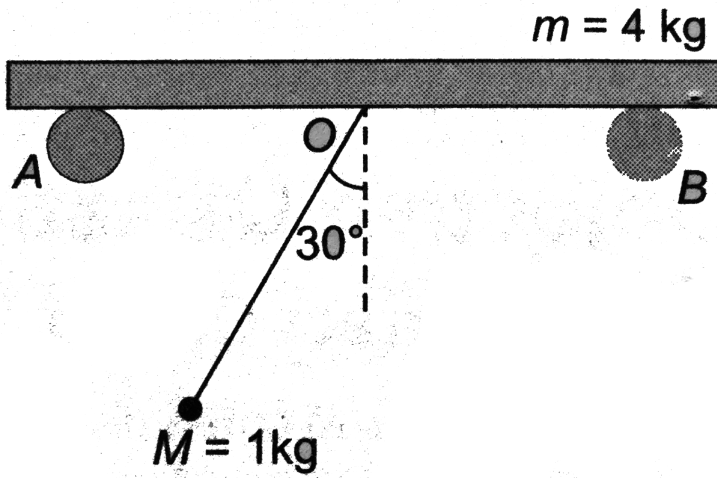

- A. (a) 0.4
- B. (b) 0.2
- C. (c) 0.25
- D. (d) 0.5

**Answer: B**



**Watch Video Solution**

7. A ball falls vertically onto a floor with momentum  $p$  and then bounces repeatedly. If coefficient of restitution is  $e$ , then the total momentum imparted by the ball to the floor is

A. (a)  $p(1 + e)$

B. (b)  $\frac{p}{1 - e}$

C. (c)  $p\left(\frac{1 - e}{1 + e}\right)$

D. (d)  $p\left(\frac{1 + e}{1 - e}\right)$

**Answer: D**



**Watch Video Solution**

8. A bullet of mass  $m$  penetrates a thickness  $h$  of a fixed plate of mass  $M$ . If the plate was free to move, then the thickness penetrated will be

A. (a)  $\frac{Mh}{M + m}$

B. (b)  $\frac{2Mh}{M + m}$

$$C. (c) \frac{mh}{2(M+m)}$$

$$D. (d) \frac{Mh}{2(M+m)}$$

**Answer: A**

 **Watch Video Solution**

9. Two identical balls of equal masses A and B, are lying on a smooth surface as shown in the figure. Ball A hits the ball B (which is at rest) with a velocity  $v = 16ms^{-1}$ . What should be the minimum value of coefficient of restitution  $e$  between A and B so that B just reaches the highest point of inclined plane? ( $g = 10ms^{-2}$ )

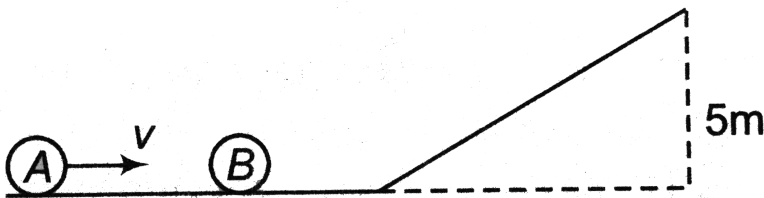

(c)  $\frac{1}{2}$

A. (a)  $\frac{2}{3}$

B. (b)  $\frac{1}{4}$

C. (c)  $\frac{1}{2}$

D. (d)  $\frac{1}{3}$

**Answer: B**



[Watch Video Solution](#)

**10.** The figure shows a metallic plate of uniform thickness and density. The value of  $l$  in terms of  $L$  so that the centre of mass of the system lies at the

interface of the triangular and rectangular portion is

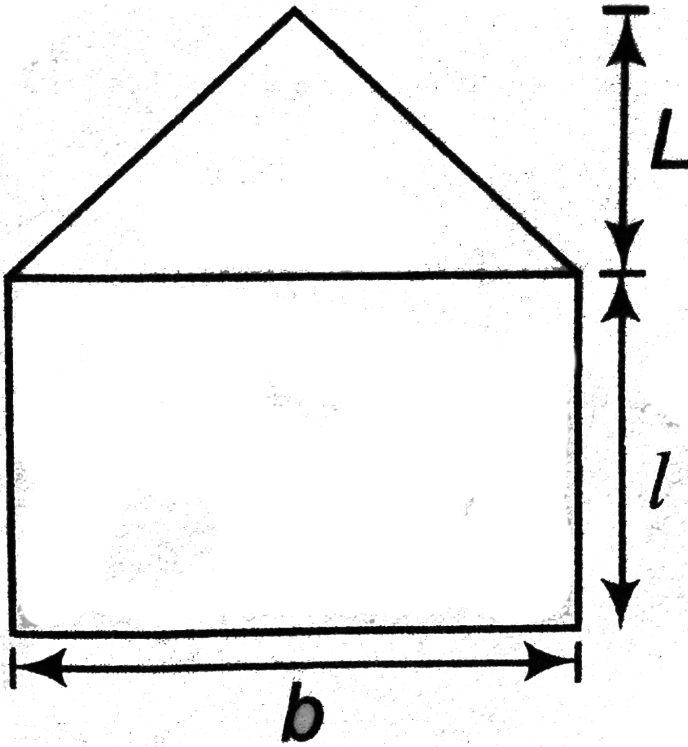

- A.  $l = \frac{L}{3}$
- B.  $l = \frac{L}{2}$
- C.  $l = \frac{L}{\sqrt{3}}$
- D.  $l = \sqrt{\frac{2}{3}}L$

Answer: C



Watch Video Solution

11. Particle A makes a head on elastic collision with another stationary particle B. They fly apart in opposite directions with equal speeds. The mass ratio will be

A.  $\frac{1}{3}$

B.  $\frac{1}{2}$

C.  $\frac{1}{4}$

D.  $\frac{2}{3}$

**Answer: A**



[Watch Video Solution](#)

12. A particle of mass  $4m$  which is at rest explodes into four equal fragments. All four fragments scattered in the same horizontal plane. Three fragments are found to move with velocity  $v$  as shown in the figure.

The total energy released in the process is

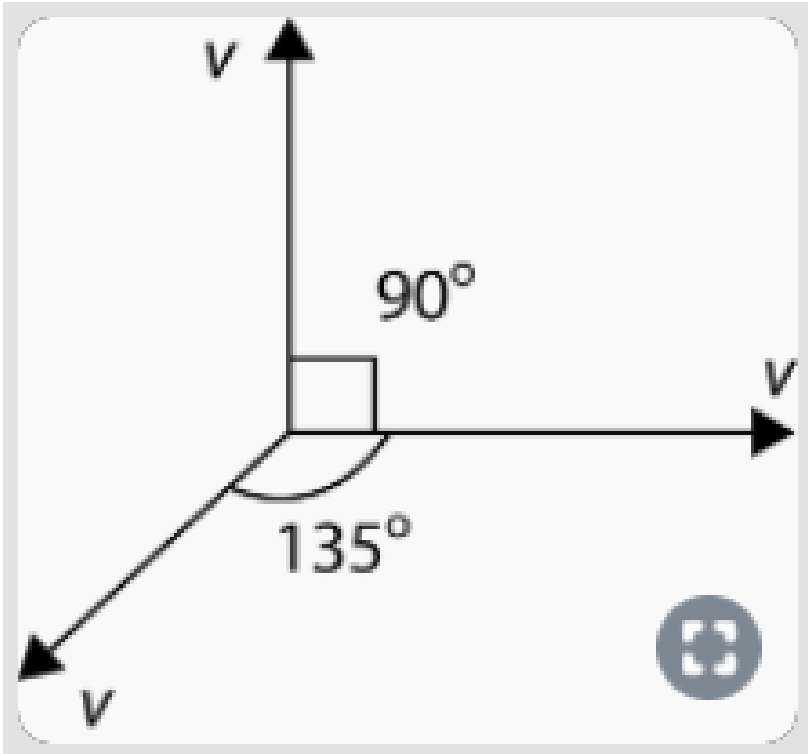

- A. (a)  $mv^2(3 - \sqrt{2})$
- B. (b)  $\frac{1}{2}mv^2(3 - \sqrt{2})$
- C. (c)  $2mv^2$
- D. (d)  $\frac{1}{2}mv^2(1 + \sqrt{2})$

**Answer: A**

 [Watch Video Solution](#)



13. A ladder of length  $L$  is slipping with its ends against a vertical wall and a horizontal floor. At a certain moment, the speed of the end in contact with the horizontal floor is  $v$  and the ladder makes an angle  $\theta = 30^\circ$  with horizontal. Then, the speed of the ladder's centre of mass must be

A. (a)  $\frac{\sqrt{3}}{2}v$

B. (b)  $\frac{v}{2}$

C. (c)  $v$

D. (d)  $2v$

**Answer: C**



[Watch Video Solution](#)

14. A body of mass  $2g$ , moving along the positive  $x$ -axis in gravity free space with velocity  $20\text{cms}^{-1}$  explodes at  $x = 1\text{m}$ ,  $t = 0$  into two pieces of masses  $2/3g$  and  $\frac{4}{3}g$ . After  $5\text{s}$ , the lighter piece is at the point

$(3m, 2m, -4m)$ . Then the position of the heavier piece at this moment, in metres is

A. (a)  $(1.5, -1, -2)$

B. (b)  $(1.5, -2, -2)$

C. (c)  $(1.5, -1, -1)$

D. (d) None of these

**Answer: D**



**Watch Video Solution**

**15.** A body of mass  $m$  is dropped from a height of  $h$ . Simultaneously another body of mass  $2m$  is thrown up vertically with such a velocity  $v$  that they collide at height  $\frac{h}{2}$ . If the collision is perfectly inelastic, the velocity of combined mass at the time of collision with the ground will be

A. (a)  $\sqrt{\frac{5gh}{4}}$

B. (b)  $\sqrt{gh}$

C. (c)  $\sqrt{\frac{gh}{4}}$

D. (d) None of these

**Answer: D**



**Watch Video Solution**

16. A man is standing on a cart of mass double the mass of man. Initially cart is at rest. Now, man jumps horizontally with velocity  $u$  relative to cart. Then work done by man during the process of jumping will be

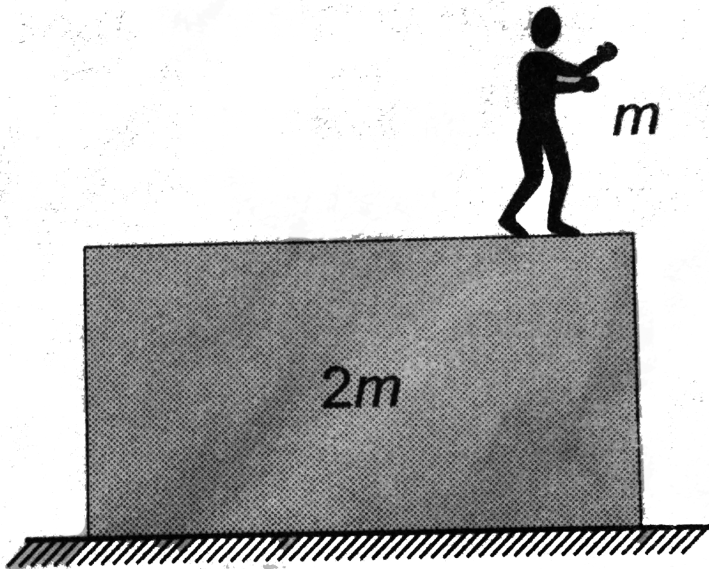

A.  $\frac{\mu^2}{2}$

B.  $\frac{3\mu^2}{4}$

C.  $\mu^2$

D. None of these

**Answer: D**



**Watch Video Solution**

17. Two balls of equal mass are projected upwards simultaneously, one from the ground with initial velocity  $50ms^{-1}$  and the other from a  $40m$  tower with initial velocity of  $30ms^{-1}$ . The maximum height attained by their COM will be

A.  $80m$

B.  $60m$

C.  $100m$

D.  $120m$

**Answer: C**



**Watch Video Solution**

**18.** A particle of mass  $m$  and momentum  $p$  moves on a smooth horizontal table and collides directly and elastically with a similar particle (of mass  $m$ ) having momentum  $-2p$ . The loss (  $-$  ) or gain (  $+$  ) in the kinetic energy of the first particle in the collision is

A. (a)  $+\frac{p^2}{2m}$

B. (b)  $-\frac{p^2}{4m}$

C. (c)  $+\frac{3p^2}{2m}$

D. (d) zero

**Answer: C**



**Watch Video Solution**

19. An equilateral triangular plate of mass  $4m$  of side  $a$  is kept as shown. Consider two cases: (i) a point mass  $4m$  is placed at the vertex  $P$  of the plate (ii) a point mass  $m$  is placed at the vertex  $R$  of the plate. In both cases the  $x$ -coordinate of centre of mass remains the same. Then  $x$  coordinate of centre of mass of the plate is

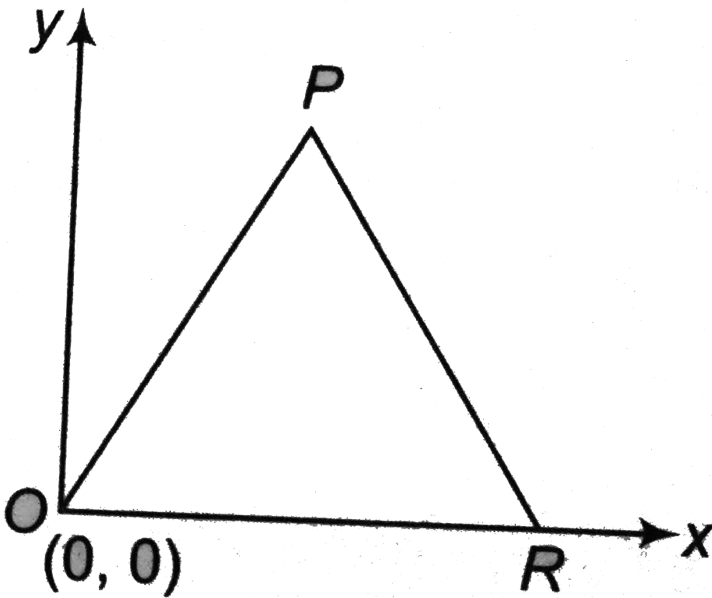

A. (a)  $\frac{a}{3}$

B. (b)  $\frac{a}{6}$

C. (c)  $\frac{6a}{7}$

D. (d)  $\frac{2a}{3}$

**Answer: B**



**Watch Video Solution**

**20.** Four cubes of side  $a$  each of mass  $40g$ ,  $20g$ ,  $10g$  and  $20g$  are arranged in  $XY$  plane as shown in the figure. The coordinates of COM of the

combination with respect to point O is

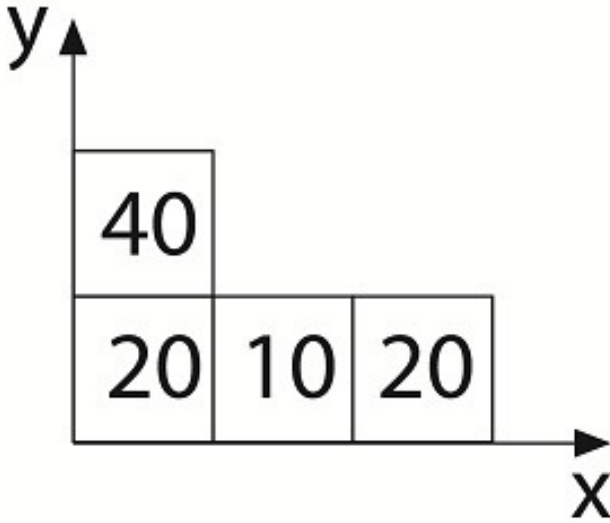

A.  $\frac{19a}{18}, \frac{17a}{18}$

B.  $\frac{17a}{18}, \frac{11a}{18}$

C.  $\frac{17a}{18}, \frac{13a}{18}$

D.  $\frac{13a}{18}, \frac{17a}{18}$

**Answer: A**



Watch Video Solution



21. A particle of mass  $m_0$ , travelling at speed  $v_0$ . Strikes a stationary particle of mass  $2m_0$ . As a result of the particle of mass  $m_0$  is deflected through  $45^\circ$  and has a final speed of  $\frac{v_0}{\sqrt{2}}$ . Then the speed of the particle of mass  $2m_0$  after this collision is

- A. (a)  $\frac{v_0}{2}$
- B. (b)  $\frac{v_0}{2\sqrt{2}}$
- C. (c)  $\sqrt{2}v_0$
- D. (d)  $\frac{v_0}{\sqrt{2}}$

**Answer: B**



Watch Video Solution

22. Two bars of masses  $m_1$  and  $m_2$  connected by a weightless spring of stiffness  $k$ , rest on a smooth horizontal plane. Bar 2 is shifted by a small

distance  $x_0$  to the left and released. The velocity of the centre of mass of the system when bar 1 breaks off the wall is



- A. (a)  $x_0 \sqrt{\frac{km_2}{m_1 + m_2}}$
- B. (b)  $\frac{x_0}{m_1 + m_2} \sqrt{km_2}$
- C. (c)  $x_0 k \frac{m_1 + m_2}{m_2}$
- D. (d)  $x_0 \frac{\sqrt{km_1}}{(m_1 + m_2)}$

**Answer: B**



**Watch Video Solution**

**23.**  $n$  elastic balls are placed at rest on a smooth horizontal plane which is circular at the ends with radius  $r$  as shown in the figure. The masses of

the balls are  $m, \frac{m}{2}, \frac{m}{2^2}, \dots, \frac{m}{2^{n-1}}$  respectively. What is the minimum velocity which should be imparted to the first ball of mass  $m$  such that  $n^{\text{th}}$  ball completes the vertical circle

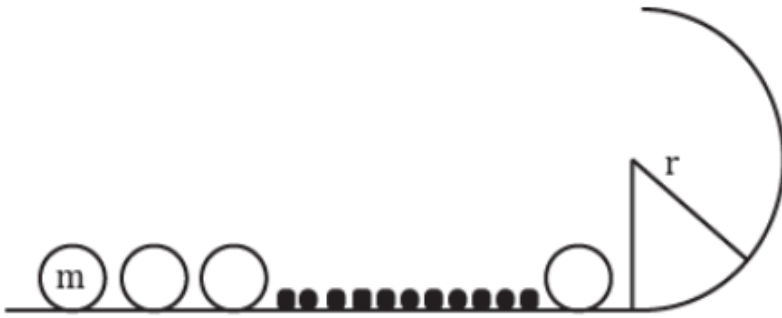

- A.  $\left(\frac{3}{4}\right)^{n-1} \sqrt{5gr}$
- B.  $\left(\frac{4}{3}\right)^{n-1} \sqrt{5gr}$
- C.  $\left(\frac{3}{2}\right)^{n-1} \sqrt{5gr}$
- D.  $\left(\frac{2}{3}\right)^{n-1} \sqrt{5gr}$

**Answer: A**

[▶ Watch Video Solution](#)

Level 2 Single Correct Option

1. In figures (a), (b) and (c) shown, the objects A, B and C are of same mass. String, spring and pulley are massless. C strikes B with velocity  $u$  in each case and sticks to it. The ratio of velocity of B in case (a) to (b) to (c) is

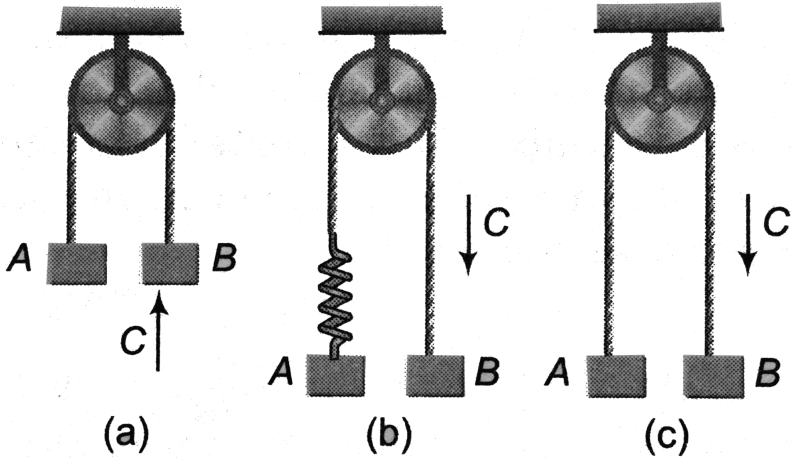

- A. (a) 1: 1: 1
- B. (b) 3: 3: 2
- C. (c) 3: 2: 2:
- D. (d) 1: 2: 3

**Answer: B**



**View Text Solution**

1. A particle of mass  $m$ , moving with velocity  $v$  collides a stationary particle of mass  $2m$ . As a result of collision, the particle of mass  $m$  deviates by  $45^\circ$  and has final speed of  $\frac{v}{2}$ . For this situation mark out the correct statement (s).



[Watch Video Solution](#)

2. A pendulum bob of mass  $m$  connected to the end of material string of length  $l$  is released from rest from horizontal position as shown in the figure. At the lowest point the bob makes an elastic collision with a stationary block of mass  $5m$ , which is kept on a frictionless surface.

Choose out the correct statement(s) for the instant just after the impact.

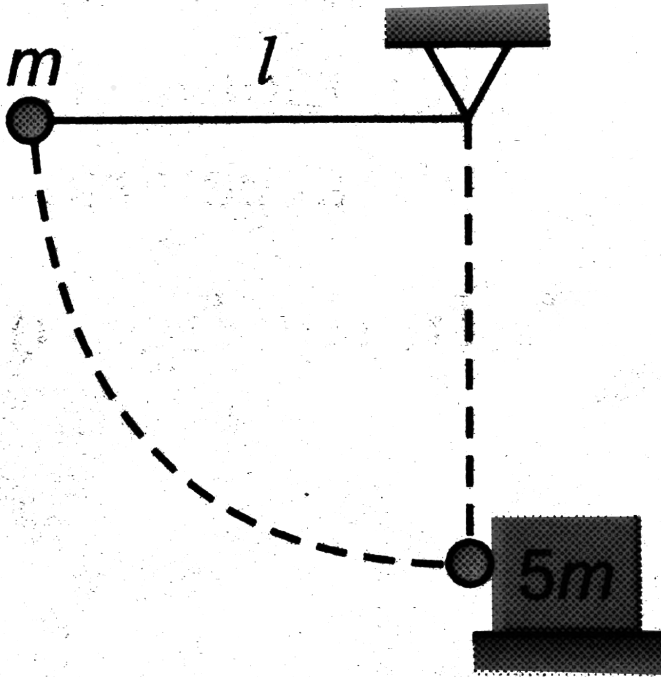

[Watch Video Solution](#)

3. A particle of mass  $m$  strikes a horizontal smooth floor with velocity  $u$  making an angle  $\theta$  with the floor and rebound with velocity  $v$  making an angle  $\theta$  with the floor. The coefficient of restitution between the particle and the floor is  $e$ . Then

[Watch Video Solution](#)

4. A particle of mass  $m$  moving with a velocity  $(3\hat{i} + 2\hat{j})ms^{-1}$  collides with another body of mass  $M$  and finally moves with velocity  $(-2\hat{i} + \hat{j})ms^{-1}$ . Then during the collision

 [Watch Video Solution](#)

5. All surfaces shown in figure are smooth. System is released from rest.  $x$  and  $y$  components of acceleration of COM are



 [Watch Video Solution](#)

6. A block of mass  $m$  is placed at rest on a smooth wedge of mass  $M$  placed at rest on a smooth horizontal surface. As the system is released

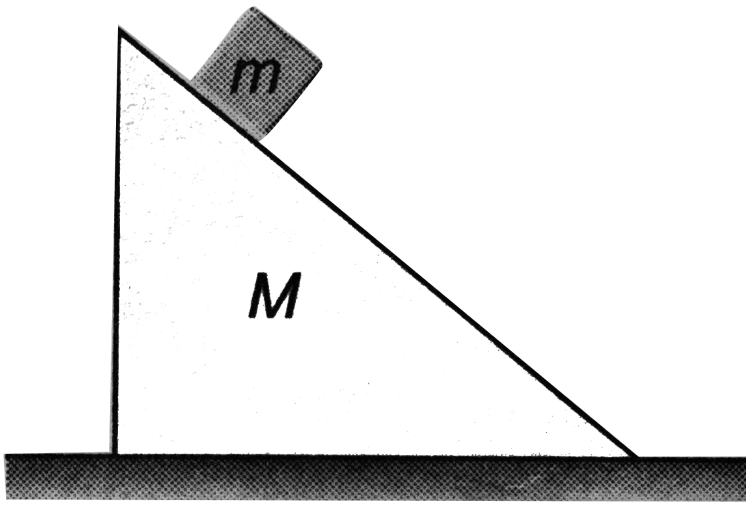

[▶ Watch Video Solution](#)

7. In the figure shown, coefficient of restitution between A and B is  $e = \frac{1}{2}$ , then

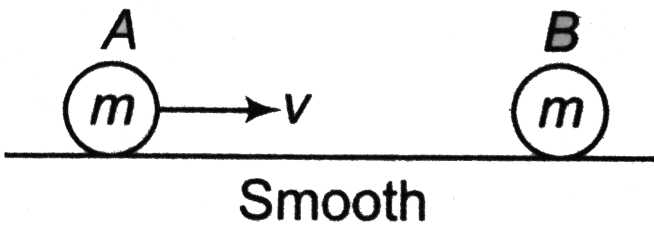

[▶ Watch Video Solution](#)



8. In case of rocket propulsion, choose the correct options.



Watch Video Solution

## Level 2 Comprehension Based

1. A block of mass  $2kg$  is attached with a spring of spring constant  $4000Nm^{-1}$  and the system is kept on smooth horizontal table. The other end of the spring is attached with a wall. Initially spring is stretched by  $5cm$  from its natural position and the block is at rest. Now suddenly an impulse of  $4kg - ms^{-1}$  is given to the block towards the wall.

Find the velocity of the block when spring acquires its natural length

A. (a)  $5ms^{-1}$

B. (b)  $3ms^{-1}$

C. (c)  $6ms^{-1}$

D. (d) None of these

**Answer: B**



**Watch Video Solution**

2. A block of mass  $2kg$  is attached with a spring of spring constant  $4000Nm^{-1}$  and the system is kept on smooth horizontal table. The other end of the spring is attached with a wall. Initially spring is stretched by  $5cm$  from its natural position and the block is at rest. Now suddenly an impulse of  $4kg - ms^{-1}$  is given to the block towards the wall.

Approximate distance travelled by the block when it comes to rest for a second time (not including the initial one) will be (Take  $\sqrt{45} = 6.70$ )

A. (a)  $30cm$

B. (b)  $25cm$

C. (c)  $40cm$

D. (d)  $20cm$

**Answer: B**



3. A uniform bar of length  $12L$  and mass  $48m$  is supported horizontally on two smooth tables as shown in the figure. A small moth (an insect) of mass  $8m$  is sitting on end  $A$  of the rod and a spider (an insect) of mass  $16m$  is sitting on the other end  $B$ . Both the insects start moving towards each other along the rod with moth moving at speed  $2v$  and the spider at half of this speed. They meet at a point  $P$  on the rod and the spider eats the moth. After this the spider moves with a velocity  $v/2$  relative to the rod towards the end  $A$ . The spider takes negligible time in eating the insect. Also, let  $v = L/T$ , where  $T$  is a constant having value 4 sec.

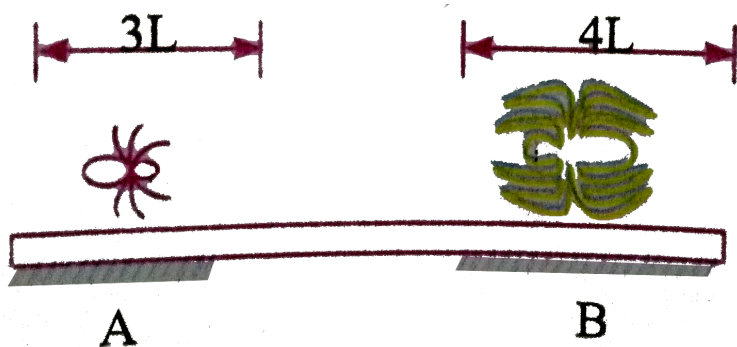

The point  $P$  is at

- A. (a) the centre of the rod

B. (b) the edge of the table supporting the end B

C. (c) the edge of the table supporting end A

D. (d) None of the above

**Answer: B**



[Watch Video Solution](#)

4. A uniform bar of length  $12L$  and mass  $48m$  is supported horizontally on two smooth tables as shown in the figure. A small moth (an insect) of mass  $8m$  is sitting on end  $A$  of the rod and a spider (an insect) of mass  $16m$  is sitting on the other end  $B$ . Both the insects start moving towards each other along the rod with moth moving at speed  $2v$  and the spider at half of this speed. They meet at a point  $P$  on the rod and the spider eats the moth. After this the spider moves with a velocity  $v/2$  relative to the rod towards the end  $A$ . The spider takes negligible time in eating the insect. Also, let  $v = L/T$ , where  $T$  is a constant having value 4 sec.

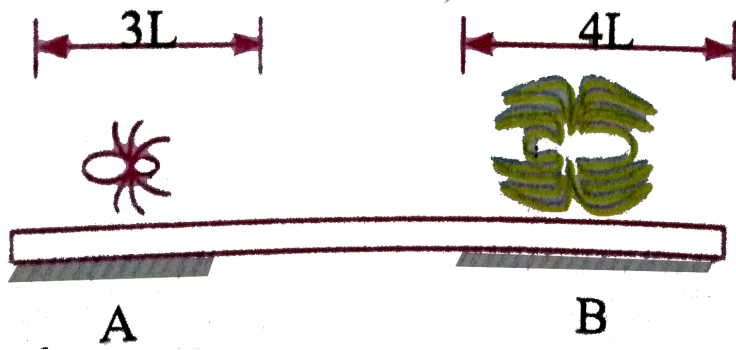

The speed of the bar after the spider eats up the moth and moves towards A is

A. (a)  $\frac{v}{2}$

B. (b)  $v$

C. (c)  $\frac{v}{6}$

D. (d)  $2v$

**Answer: C**

[Watch Video Solution](#)

Level 2 Comprehension Based Questions

1. A block of mass  $2\text{kg}$  is attached with a spring of spring constant  $4000\text{Nm}^{-1}$  and the system is kept on smooth horizontal table. The other end of the spring is attached with a wall. Initially spring is stretched by  $5\text{cm}$  from its natural position and the block is at rest. Now suddenly an impulse of  $4\text{kg} - \text{ms}^{-1}$  is given to the block towards the wall.

Approximate distance travelled by the block when it comes to rest for a second time (not including the initial one) will be (Take  $\sqrt{45} = 6.70$ )

Displacement of the rod by the time the insect meet the moth is

A. (a)  $\frac{L}{2}$

B. (b)  $L$

C. (c)  $\frac{3L}{4}$

D. (d) zero

**Answer: D**



[View Text Solution](#)

2. A uniform bar of length  $12L$  and mass  $48m$  is supported horizontally on two fixed smooth tables as shown in figure. A small moth (an insect) of mass  $8m$  is sitting on end A of the rod and a spider (an insect) of mass  $16m$  is sitting on the other end B. Both the insects moving towards each other along the rod with moth moving at speed  $2v$  and the spider at half this speed (absolute). They meet at a point P on the rod and the spider eats the moth. After this the spider moves with a velocity  $\frac{v}{2}$  relative to the rod towards the end A. The spider takes negligible time in eating on the other insect. Also, let  $v = \frac{L}{T}$  where T is a constant having value  $4s$ .

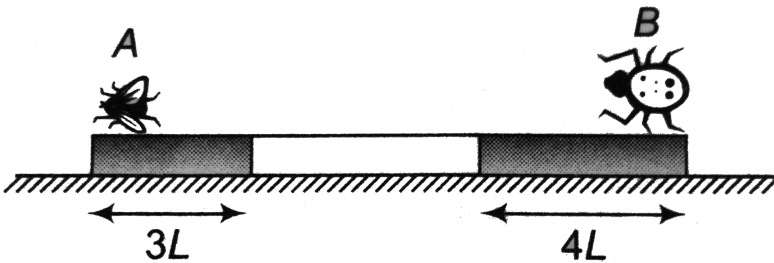

After starting from end B of the rod the spider reaches the end A at a time

A. (a)  $40s$

B. (b)  $30s$

C. (c)  $80s$

D. (d)  $10s$

**Answer: C**



[View Text Solution](#)

3. A uniform bar of length  $12L$  and mass  $48m$  is supported horizontally on two fixed smooth tables as shown in figure. A small moth (an insect) of mass  $8m$  is sitting on end A of the rod and a spider (an insect) of mass  $16m$  is sitting on the other end B. Both the insects moving towards each other along the rod with moth moving at speed  $2v$  and the spider at half this speed (absolute). They meet at a point P on the rod and the spider eats the moth. After this the spider moves with a velocity  $\frac{v}{2}$  relative to the rod towards the end A. The spider takes negligible time in eating on the other insect. Also, let  $v = \frac{L}{T}$  where T is a constant having value  $4s$ .



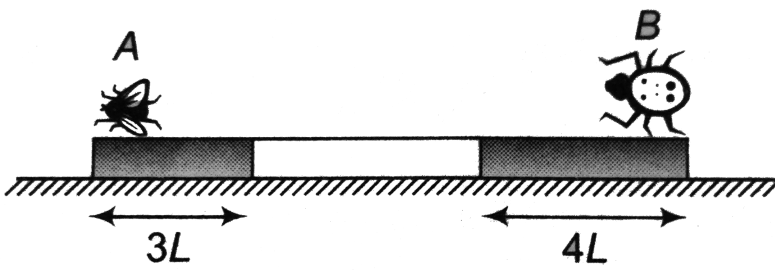

By what distance the centre of mass of the rod shifts during this time?

A. (a)  $\frac{8L}{3}$

B. (b)  $\frac{4L}{3}$

C. (c)  $L$

D. (d)  $\frac{L}{3}$

**Answer: A**

 [View Text Solution](#)

Level 2 Subjective

1. A ladder AP of length  $5m$  inclined to a vertical wall is slipping over a horizontal surface with velocity of  $2m/s$ , when A is at distance  $3m$  from ground. What is the velocity of COM at this moment?

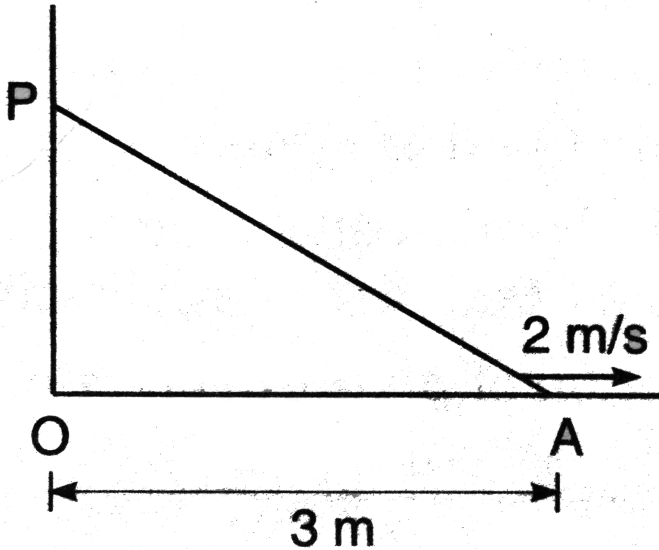

[▶ Watch Video Solution](#)

2. A ball of negligible size and mass  $m$  is given a velocity  $v_0$  on the centre of the cart which has a mass  $M$  and is originally at rest. If the coefficient of restitution between the ball and walls A and B is  $e$ . Determine the velocity of the ball and the cart just after the ball strikes A. Also,

determine the total time needed for the ball to strike A, rebound, then strike B, and rebound and then return to the centre of the cart. Neglect friction.

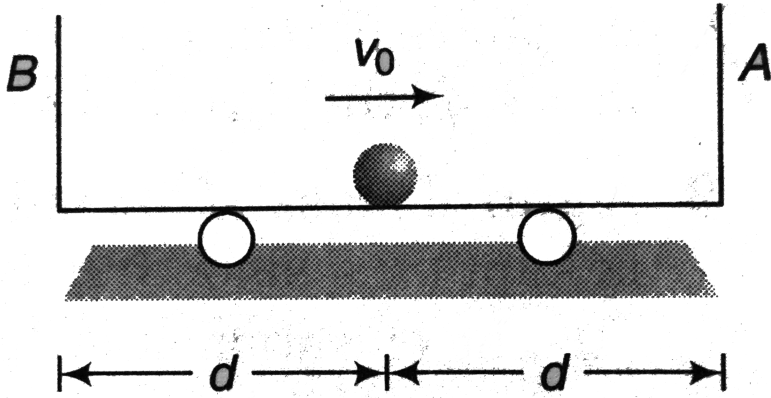

[▶ Watch Video Solution](#)

3. Two point masses  $m_1$  and  $m_2$  are connected by a spring of natural length  $l_0$ . The spring is compressed such that the two point masses touch each other and then they are fastened by a string. Then the system is moved with a velocity  $v_0$  along positive x-axis. When the system reached the origin, the string breaks ( $t = 0$ ). The position of the point mass  $m_1$  is given by  $x_1 = v_0 t - A(1 - \cos \omega t)$  where A and  $\omega$  are constants. Find the

position of the second block as a function of time. Also, find the relation between  $A$  and  $l_0$ .

 [Watch Video Solution](#)

4. A small sphere of radius  $R$  is held against the inner surface of larger sphere of radius  $6R$  (as shown in figure). The masses of large and small spheres are  $4M$  and  $M$  respectively. This arrangement is placed on a horizontal table. There is no friction between any surfaces of contact. The small sphere is now released. Find the coordinates of the centre of the large sphere, when the smaller sphere reaches the other extreme position.

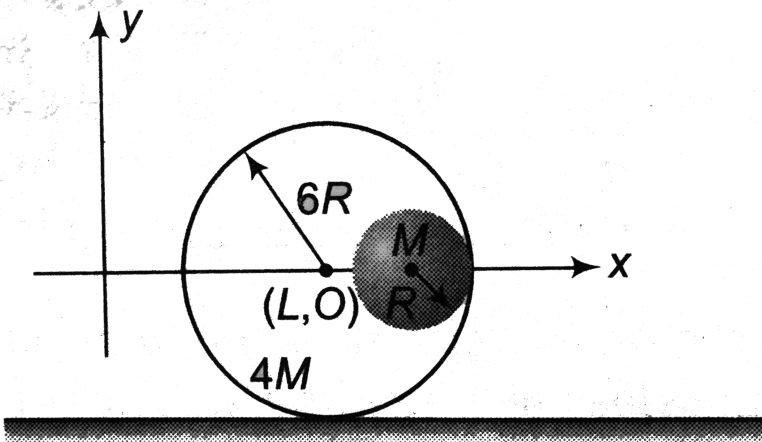



5. A chain of length  $l$  and mass  $m$  lies in a pile on the floor. If its end A is raised vertically at a constant speed  $v_0$ , express in terms of the length  $y$  of chain which is off the floor at any given instant.

(a) The magnitude of the force  $P$  applied to end A.

(b) Energy lost during the lifting of the chain.

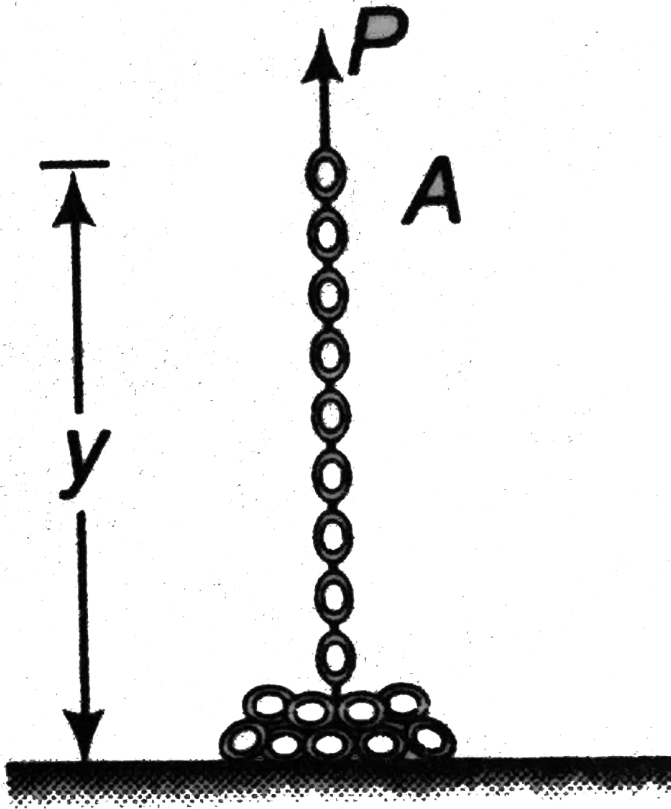

Watch Video Solution

6. (i) O is a fixed peg at a height  $H$  above a perfectly inelastic smooth horizontal plane. A light inextensible string of length  $L (> H)$  has one

end attached to  $O$  and the other end is attached to a heavy particle. The particle is held at the level of  $O$  with string horizontal and just taut and released from rest. Find the height of the particle above the plane when it comes to rest for the first time after the release.

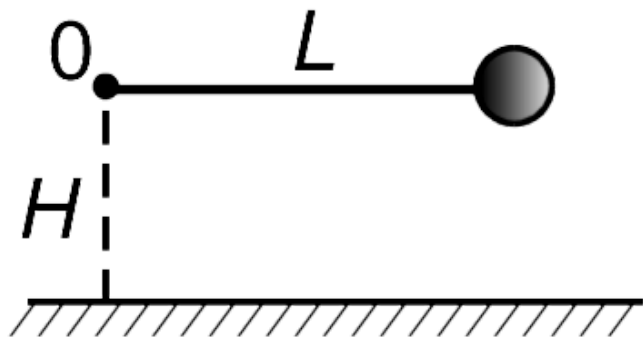

(ii) The bob of a pendulum has mass  $m$  and the length of pendulum is  $l$ . It is initially at rest with the string vertical and the point of suspension at a height  $2l$  above the floor. A particle  $P$  of mass  $\frac{m}{2}$  moving horizontally along  $-ve$   $x$ -direction with velocity  $\sqrt{2gl}$  collides with the bob and comes to rest. The bob swings and when it comes to rest for the first time, another particle  $Q$  of mass  $m$  moving horizontally along  $y$  direction collides with the bob and sticks to it. It is observed that the bob now moves in a horizontal circle.

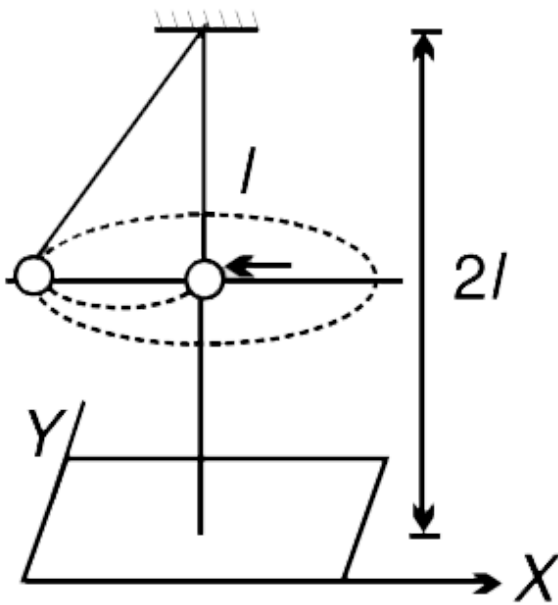

- Find tension in string just before the second collision.
- Find the height of the circular path above the floor.
- Find the time period of the circular motion.
- The string breaks during the circular motion at time  $t = 0$ . At what time the bob will hit the floor ?



[Watch Video Solution](#)

7. A particle of mass  $2m$  is projected at an angle of  $45^\circ$  with horizontal with a velocity of  $20\sqrt{2}m/s$ . After  $1s$  explosion takes place and the



particle is broken into two equal pieces. As a result of explosion one part comes to rest. Find the maximum height attained by the other part. Take  $g = 10m / s^2$ .

 [Watch Video Solution](#)

8. A sphere of mass  $m$ , impinges obliquely on a sphere, of mass  $M$ , which is at rest. Show that, if  $m = eM$ , the directions of motion of the sphere after impact are at right angles.

 [Watch Video Solution](#)

9. A gun of mass  $M$ (including the carriage) fires a shot of mass  $m$ . The gun along with the carriage is kept on a smooth horizontal surface. The muzzle speed of the bullet  $v_r$  is constant. Find

(a) The elevation of the gun with horizontal at which maximum range of bullet with respect to the ground is obtained.

(b) The maximum range of the bullet.

 [Watch Video Solution](#)

10. A ball is released from rest relative to the elevator at a distance  $h_1$  above the floor. The speed of the elevator at the time of ball release is  $v_0$ . Determine the bounce height  $h_2$  relative to elevator of the ball (a) if  $v_0$  is constant and (b) if an upward elevator acceleration  $a = \frac{g}{4}$  begins at the instant the ball is released. The coefficient of restitution for the impact is  $e$ .

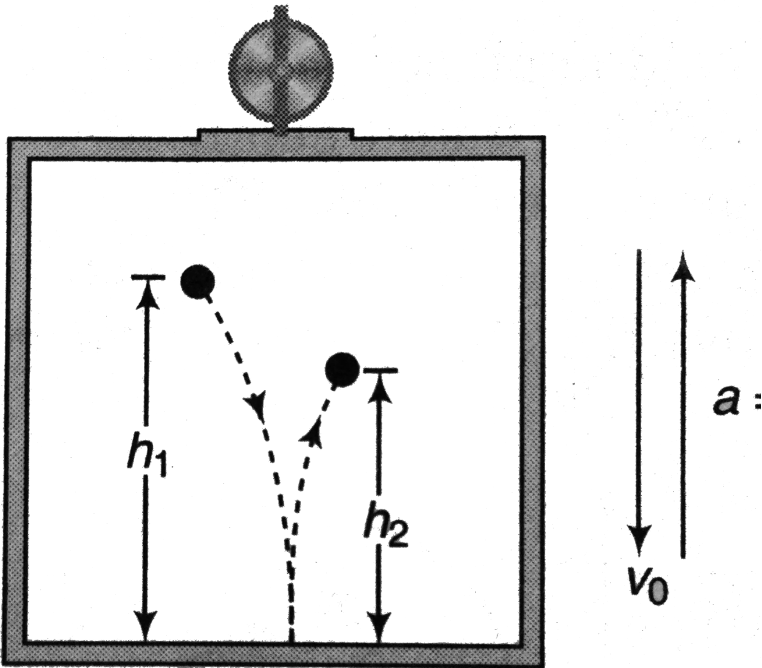

11. A plank of mass  $5\text{kg}$  is placed on a frictionless horizontal plane. Further a block of mass  $1\text{kg}$  is placed over the plank. A massless spring of natural length  $2\text{m}$  is fixed to the plank by its one end. The other end of spring is compressed by the block by half of spring's natural length. They system is now released from the rest. What is the velocity of the plank when block leaves the plank? (The stiffness constant of spring is  $100\text{N/m}$ )

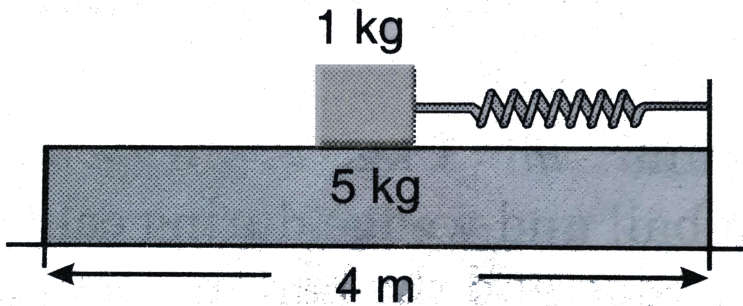

[▶ Watch Video Solution](#)

12. To test the manufactured properties of  $10\text{N}$  steel balls, each ball is released from rest as shown and strikes a  $45^\circ$  inclined surface. If the coefficient of restitution is to be  $e = 0.8$ , determine the distance  $s$ , where

the ball must strike the horizontal plane at A. At what speed does the ball strike at A? ( $g = 9.8 \text{ m/s}^2$ )

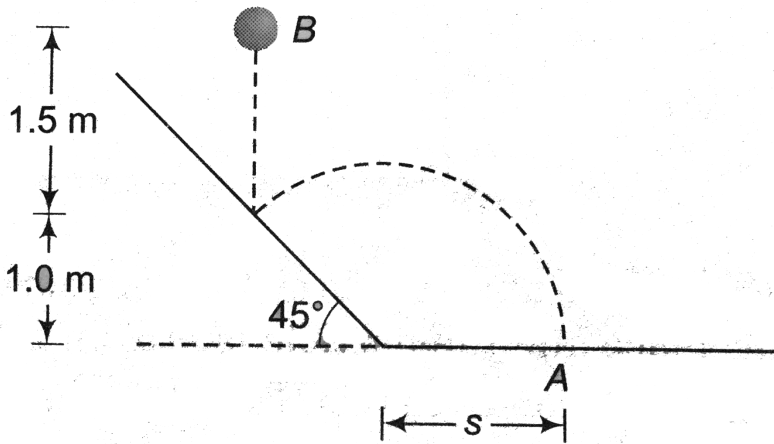

[Watch Video Solution](#)

13. Two particles A and B of equal masses lie close together on a horizontal table and are connected by a light inextensible string of length  $l$ . A is projected vertically upwards with a velocity  $\sqrt{10gl}$ . Find the velocity with which it reaches the table again.

[Watch Video Solution](#)

14. A small cube of mass  $m$  slides down a circular path of radius  $R$  cut into a large block of mass  $M$ , as shown in figure.  $M$  rests on a table, and both blocks move without friction. The blocks are initially at rest, and  $m$  starts from the top of the path. Find the horizontal distance from the bottom of block where cube hits the cable

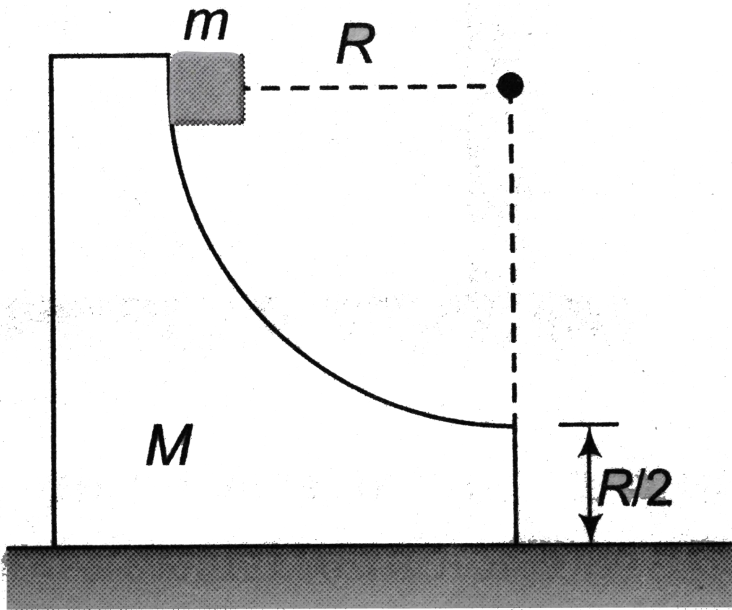

Watch Video Solution

15. A thin hoop of mass  $M$  and radius  $r$  is placed on a horizontal plane. At the initial instant, the hoop is at rest. A small washer of mass  $m$  with zero initial velocity slides from the upper point of the hoop along a smooth groove in the inner surfaces of the hoop. Determine the velocity  $u$  of the centre of the hoop at the moment when the washer is at a certain point  $A$  of the hoop, whose radius vector forms an angle  $\phi$  with the vertical (figure). The friction between the hoop and the plane should be neglected



[Watch Video Solution](#)

16. A shell of mass  $1\text{ kg}$  is projected with velocity  $20\text{ m/s}$  at an angle  $60^\circ$  with horizontal. It collides inelastically with a ball of mass  $1\text{ kg}$  which is suspended through a thread of length  $1\text{ m}$ . The other end of the thread is attached to the ceiling of a trolley of mass  $\frac{4}{3}\text{ kg}$  as shown in figure. Initially the trolley is stationary and it is free to move along horizontal rails without any friction. What is the maximum deflection of the thread

with vertical? String does not slack. Take  $g = 10\text{ m/s}^2$ .

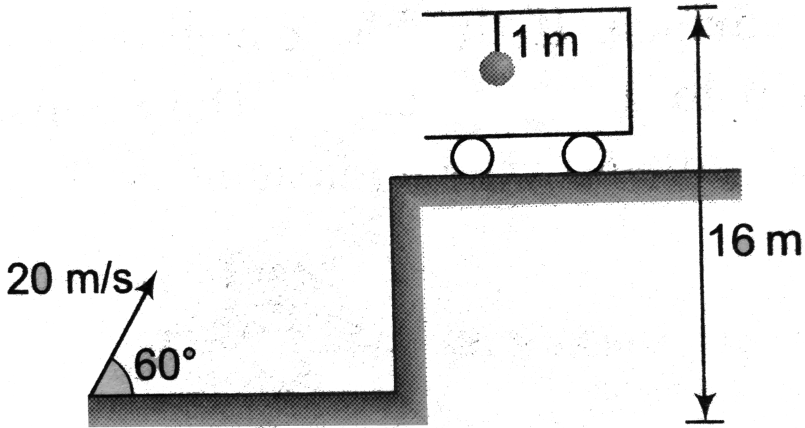

[Watch Video Solution](#)

17. A small ball is projected at an angle  $\alpha$  between two vertical walls such that in the absence of the wall its range would have been  $5d$ . Given that all the collisions are perfectly elastic, find.

(a) maximum height attained by the ball.

(b) total number of collisions with the walls before the ball comes back to the ground, and

(c) point at which the ball finally falls. The walls are supposed to be very

tall.

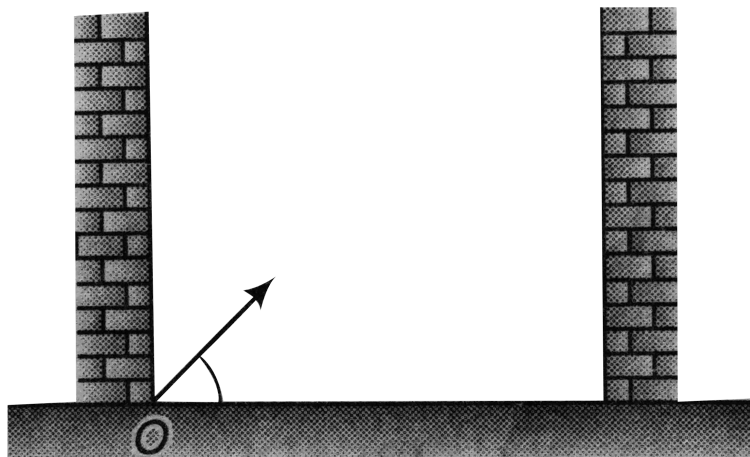

[▶ Watch Video Solution](#)

**18.** Two large rigid vertical walls A and B are parallel to each other and separated by  $10m$ . A particle of mass  $10g$  is projected with an initial velocity of  $20m/s$  at  $45^\circ$  to the horizontal from point P on the ground, such that  $AP = 5m$ . The plane of motion of the particle is vertical and perpendicular to the walls. Assuming that all the collisions are perfectly elastic, find the maximum height attained by the particle and the total number of collisions suffered by the particle with the walls before it hits



ground. Take  $g = 10\text{m/s}^2$ .



 [Watch Video Solution](#)

**19.** Two blocks of masses  $2\text{kg}$  and  $M$  are at rest on an inclined plane and are separated by a distance of  $6.0\text{m}$  as shown. The coefficient of friction between each block and the inclined plane is  $0.25$ . The  $2\text{kg}$  block is given a velocity of  $10.0\text{m/s}$  up the inclined plane. It collides with  $M$ , comes back and has a velocity of  $1.0\text{m/s}$  when it reaches its initial position. The other block  $M$  after the collision moves  $0.5\text{m}$  up and comes to rest. Calculate the coefficient of restitution between the blocks and the mass of the block  $M$ .

[Take  $\sin \theta = \tan \theta = 0.05$  and  $g = 10\text{m/s}^2$ ]

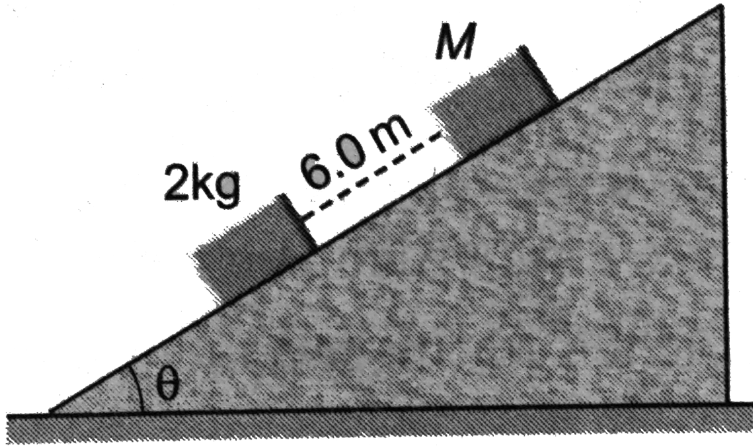

[▶ Watch Video Solution](#)

20. A small block of mass  $m$  is placed on top of a smooth hemisphere also of mass  $m$  which is placed on a smooth horizontal surface. If the block begins to slide down due to a negligible small impulse, show that it will lose contact with the hemisphere when the radial line through vertical

makes an angle  $\theta$  given by the equation  $\cos^3 \theta - 6 \cos \theta + 4 = 0$ .

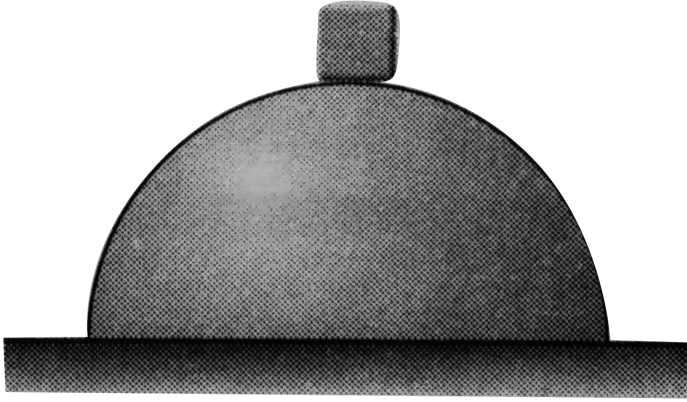

[▶ Watch Video Solution](#)

21. A ball is projected from a given point with velocity  $u$  at some angle with the horizontal and after hitting a vertical wall returns to the same point. Show that the distance of the point from the wall must be less than  $\frac{eu^2}{(1+e)g}$ , where  $e$  is the coefficient of restitution.

[▶ Watch Video Solution](#)

## Examples

1. Two bodies of masses 1 kg and 2 kg are located at (1,2) and (-1,3), respectively. Calculate the coordinates of center of mass.

 [Watch Video Solution](#)

2. Two particles of masses 1kg and 2kg are located at  $x = 0$  and  $x = 3m$ .

Find the position of their centre of mass.

A.  $25m$

B.  $2m$

C.  $2.5m$

D.  $1m$

**Answer: B**

 [Watch Video Solution](#)

3. Two points objects of mass 1.5g and 2.5g respectively are a distance of 16cm apart, the center of mass is at distance x from the object of mass 1.5g. Find the value of x

A. 12cm

B. 14cm

C. 10cm

D. 16cm

**Answer: C**



[Watch Video Solution](#)

4. The position vectors of three particles of mass  $m_1 = 1kg$ ,  $m_2 = 2kg$  and  $m_3 = 3kg$  are  $r_1 = (\hat{i} + 4\hat{j} + \hat{k})m$ ,  $r_2 = (\hat{i} + \hat{j} + \hat{k})m$  and  $r_3 = (2\hat{i} - \hat{j} - 2\hat{k})m$ , respectively. Find the position vector of their center of mass.

$$\text{A. } r_{cm} = \frac{1}{2}(3i + j - 2k)m$$

$$\text{B. } r_{cm} = \frac{1}{2}(3i + 2j - k)m$$

$$\text{C. } r_{cm} = \frac{1}{2}(3i + 3j - k)m$$

$$\text{D. } r_{cm} = \frac{1}{2}(3i + j - k)m$$

**Answer: D**

 [Watch Video Solution](#)

5. Four particles of masses 1kg, 2kg, 3kg and 4kg are placed at the four vertices A, B, C and D of a square of side 1m. Find the position of centre of mass of the particles. Assume that D is situated at the origin.

 [Watch Video Solution](#)

6. Three point masses  $m_1 = 2Kg$ ,  $m_2 = 4kg$  and  $m_3 = 6kg$  are kept at the three corners of an equilateral triangle of side 1 m. Find the location of their center of mass.



[Watch Video Solution](#)

7. The linear density of a thin rod of length 1m lies as  $\lambda = (1 + 2x)$ , where  $x$  is the distance from its one end. Find the distance of its center of mass from this end.



[Watch Video Solution](#)

8. A straight rod of length  $L$  has one of its end at the origin and the other at  $X = L$ . If the mass per unit length of the rod is given by  $Ax$  where  $A$  is constant, where is its centre of mass?



[Watch Video Solution](#)

9. Find the position of center of mass of the uniform lamina shown in figure, if small disc of radius  $\frac{a}{2}$  is cut from disc of radius  $a$ .

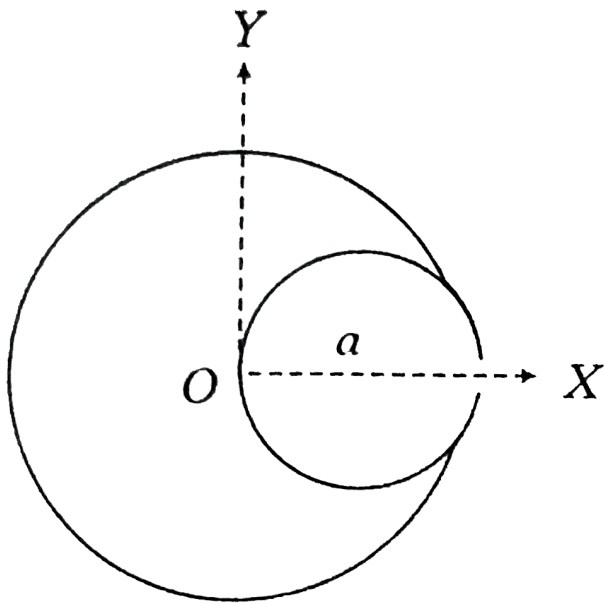

- A.  $\left(-\frac{a}{6}, a\right)$
- B.  $\left(-\frac{a}{2}, 0\right)$
- C.  $\left(-\frac{a}{6}, 0\right)$
- D.  $\left(-\frac{a}{3}, 0\right)$

**Answer: C**



**Watch Video Solution**



10. A small disc of radius 2cm is cut from a disc of radius 6cm. If the distance their centers is 3.2cm, what is the shift in the center of mass of the disc?

A.  $-0.4\text{cm}$

B.  $-0.5\text{cm}$

C.  $-0.24\text{cm}$

D.  $-0.6\text{cm}$

**Answer: A**



[Watch Video Solution](#)

11. Two identical rods each of mass  $m$  and length are connected as shown.

Locate  $c. m.$

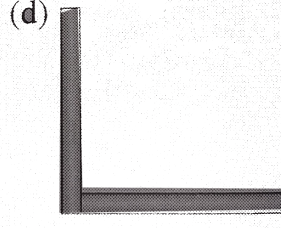
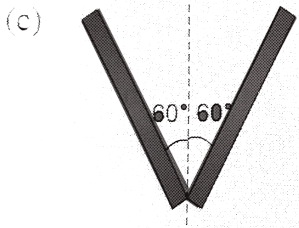
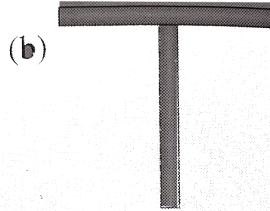
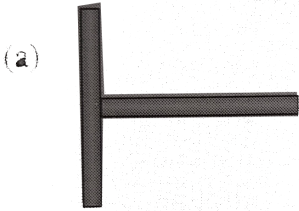

 [Watch Video Solution](#)

12. Two blocks of masses  $5kg$  and  $2kg$  are placed on a frictionless surface and connected by a spring. An external kick gives a velocity of  $14m/s$  to the heavier block in the direction of lighter one. The magnitudes of velocities of two blocks in the centre of mass frame after the kick are respectively :

A.  $4m/s$  ,  $-10m/s$

B.  $4m/s$  ,  $10m/s$

C.  $-4m/s$  ,  $10m/s$

D.  $4m/s$  ,  $10m/s$

Answer: A



Watch Video Solution

13. Find the velocity of center of mass of the system shown in the figure.

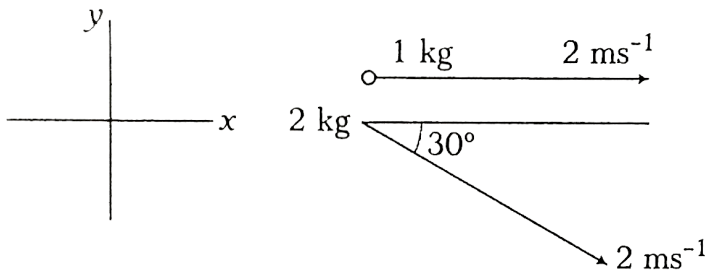

Watch Video Solution

14. Two particles of masses  $2 \text{ kg}$  and  $4 \text{ kg}$  are approaching each other with acceleration  $1 \text{ ms}^{-2}$  and  $2 \text{ ms}^{-2}$ , respectively, on a smooth horizontal surface. Find the magnitude of acceleration of center of mass of the system.

A. 1

B. 2

C. 3

D. 4

**Answer: A**



[Watch Video Solution](#)

**15.** Two particles of mass  $m_1$  and  $m_2$  are projected from the top of a tower. The particle  $m_1$  is projected vertically downward with speed  $u$  and  $m_2$  is projected horizontally with same speed. Find acceleration of CM of system of particles by neglecting the effect of air resistance.



[Watch Video Solution](#)

**16.** Two particles of masses  $2m$  and  $3m$  are placed at separation  $d$  on a smooth surface. They move towards each other due to mutual attractive

force. Find (a) acceleration of c.m. (b) Velocity of c.m. when separation between particles becomes  $d/3$ . (c) At what distance from the initial position of mass  $2m$ , the particles collide.

 [Watch Video Solution](#)

17. In the arrangement shown in Figure,  $m_A = 2kg$  and  $m_B = 1kg$ . String is light and inextensible. Find the acceleration of centre of mass of both

the blocks. Neglect friction everywhere.

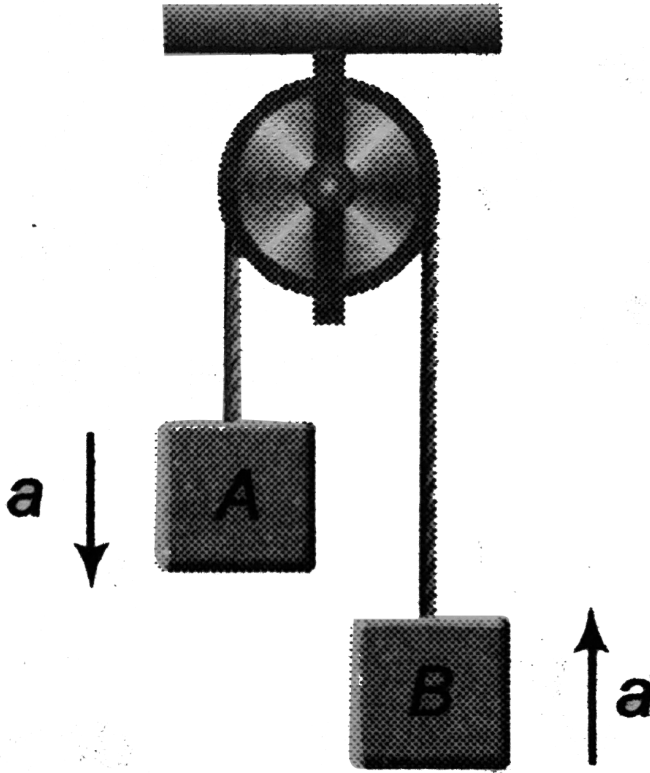

[Watch Video Solution](#)

18. Two particles A and B of mass 1 kg and 2 kg respectively are projected in the direction shown in figure with speeds  $u_A = 200\text{ms}^{-1}$  and  $u_B = 50\text{ms}^{-1}$ . Initially they were 90 m apart. Find the maximum height attained by the center of mass of the particles. Assume acceleration due

to gravity to be constant. (Take,  $g = 10\text{m/s}^{-2}$ .)

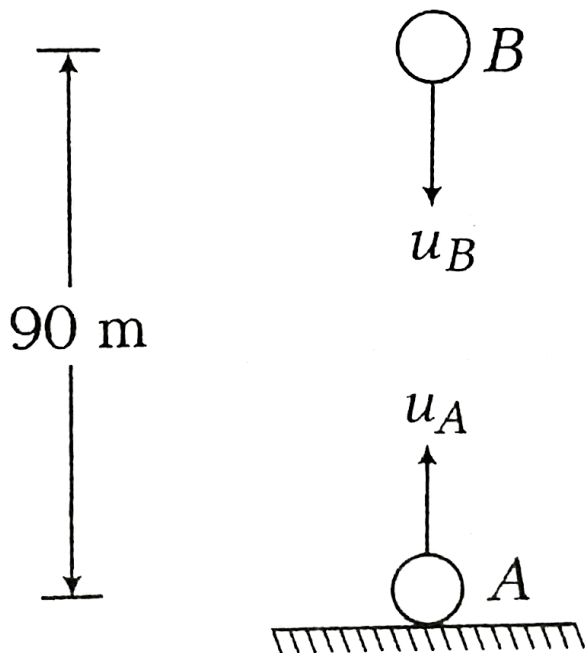

[▶ Watch Video Solution](#)

19. A bullet mass  $10\text{g}$  is fired from a gun of mass  $1\text{ kg}$ . If the recoil velocity is  $5\text{ m/s}$ , the velocity of the muzzle is

A.  $500\text{m/sec}$

B.  $100\text{m/sec}$

C. 50m/sec

D. None of The Above

**Answer: A**



[Watch Video Solution](#)

**20.** The object at rest suddenly explodes into three parts with the mass ratio 2:1:1. The parts of equal masses move at right angles to each other with equal speeds. What is the speed of the third part after the explosion?



[Watch Video Solution](#)

**21.** A  $0.5\text{kg}$  ball moving with a speed of  $12\text{m/s}$  strikes a hard wall at an angle of  $30^\circ$  with the wall. It is reflected with the same speed and at the same angle. If the ball is in contact with the wall for  $0.25\text{s}$ , the average



force acting on the wall is

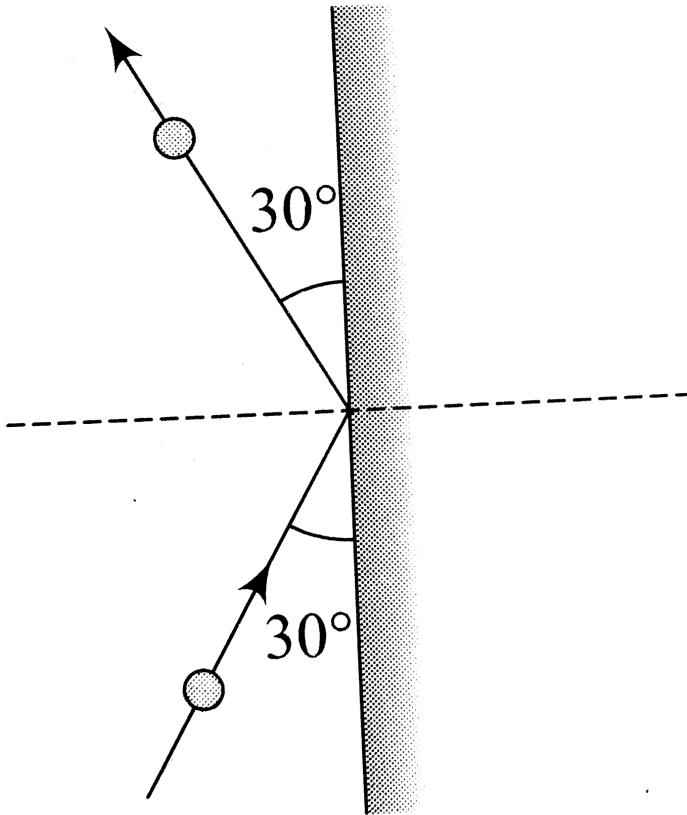

[▶ Watch Video Solution](#)

22. A man of mass  $m_1$  is standing on a platform of mass  $m_2$  kept on a smooth horizontal surface. The man starts moving on the platform with a velocity  $v_r$  relative to the platform. Find the recoil velocity of platform.

[▶ Watch Video Solution](#)

23. A wooden plank of mass  $20\text{kg}$  is resting on a smooth horizontal floor. A man of mass  $60\text{kg}$  starts moving from one end of the plank to the other end. The length of the plank is  $10\text{m}$ . Find the displacement of the plank over the floor when the man reaches the other end of the plank.

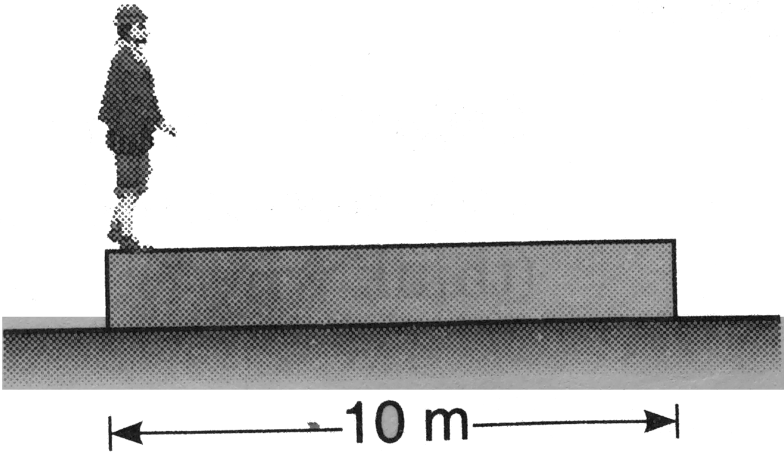

[▶ Watch Video Solution](#)

24. A block of mass  $M$  with a semi-circular track of radius  $R$  rests on a smooth floor. A sphere of mass  $m$  and radius  $r$  is released from rest from

A. Find the velocity of sphere and track , when the sphere reaches  $B$ .

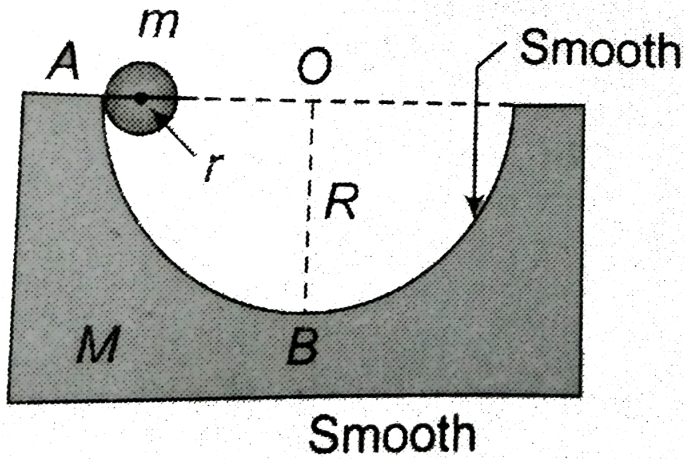

[▶ Watch Video Solution](#)

25. A particle of mass  $m$  is projected with velocity making an angle of  $45^\circ$  with the horizontal. When the particle lands on the level ground the magnitude of the change in its momentum will be .

[▶ Watch Video Solution](#)

**26.** A disc of mass  $100\text{ g}$  is kept floating horizontally in air by firing bullets, each of mass  $5\text{ g}$  with the same velocity at the same rate of  $10$  bullets per second. The bullets rebound with the same speed in opposite direction. Find the velocity of each bullet at the time of impact.



[Watch Video Solution](#)

**27.** Two balls of masses  $m$  and  $2m$  moving in opposite directions collide head on elastically with velocities  $v$  and  $2v$ . Find their velocities after collision.



[Watch Video Solution](#)

**28.** A simple pendulum of length  $1\text{ m}$  has a wooden bob of mass  $1\text{ kg}$ . It is struck by a bullet of mass  $10\text{ g}$  moving with a speed of  $200\text{ m/s}$ . The bullet gets embedded into the bob. Obtain the height to which the bob rises before swinging back.

Take  $g = 10\text{ m/s}^2$ .



[Watch Video Solution](#)

**29.** A body falling on the ground from a height of 10m, rebounds to a height 2.5 m Calculate

(i) The percentage loss in KE

(ii) Ratio of the velocities of the body just before and just after the collision.



[Watch Video Solution](#)

**30.** A pendulum bob of mass  $10^{-2}kg$  is raised to a height  $5 \times 10^{-2} m$  and then released. At the bottom of its swing, it picks up a mass  $10^{-3}kg$ .

To what height will the combined mass rise?

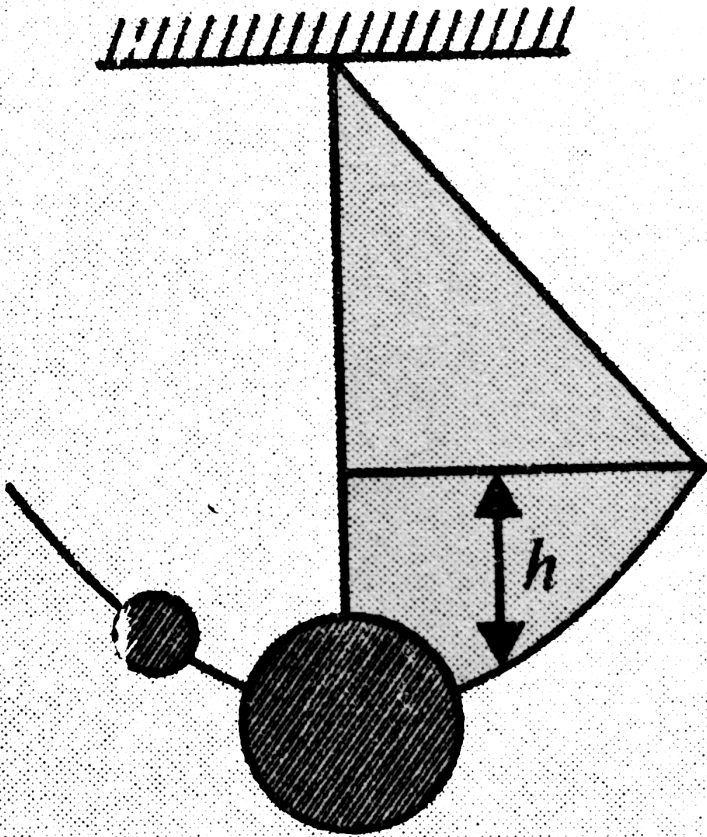

Watch Video Solution

31. A plank of mass  $5kg$  is placed on a frictionless horizontal plane. Further a block of mass  $1kg$  is placed over the plank. A massless spring of natural length  $2m$  is fixed to the plank by its one end. The other end of

spring is compressed by the block by half of spring's natural length. They system is now released from the rest. What is the velocity of the plank when block leaves the plank? (The stiffness constant of spring is  $100\text{N/m}$ )

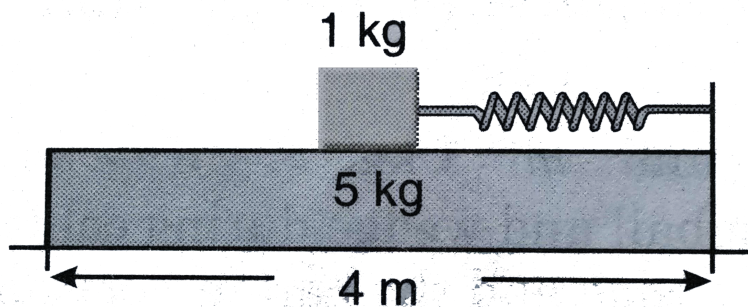

[Watch Video Solution](#)

32. An object of mass  $40\text{ kg}$  and having velocity  $4\text{ m/s}$  collides with another object of mass  $60\text{ kg}$  having velocity  $2\text{ m/s}$ . The loss of energy when the collision is perfectly inelastic is

[Watch Video Solution](#)

**33.** A particle of mass  $m$  moving with speed  $u$  collides perfectly inelastically with another particle of mass  $2m$  at rest. Find loss of kinetic energy of system in the collision.

 [Watch Video Solution](#)

**34.** The mass of the railway carriage is  $8000\text{ kg}$  which is moving with the speed of  $54\text{ km h}^{-1}$  collides with the another stationary carriage of same mass. Determine the loss in kinetic energy in this process.

 [Watch Video Solution](#)

**35.** A ball is moving with velocity  $2\text{ m/s}$  towards a heavy wall moving towards the ball with speed  $1\text{ m/s}$  as shown in figure. Assuming collision



to be elastic, find the velocity of ball immediately after the collision.

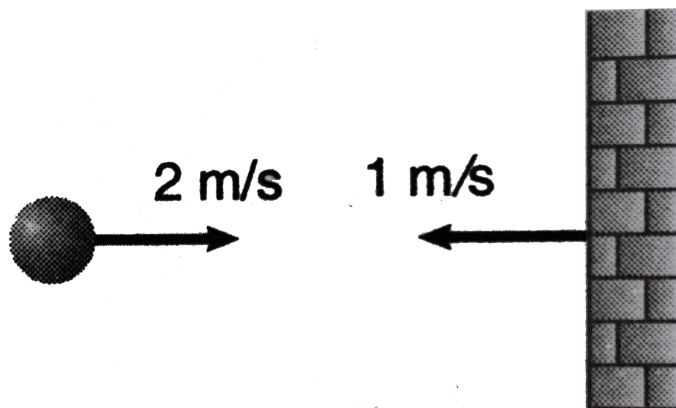

[▶ Watch Video Solution](#)

**36.** A ball of mass 2kg moving with speed 5m/s collides directly with another ball of mass 3kg moving in the same direction with speed 4m/s. The coefficient of restitution is  $\frac{2}{3}$ . Find the velocities of both ball after the collision.

[▶ Watch Video Solution](#)

37. A block of mass 5 kg moves from left to right with a velocity of  $2m.s^{-1}$  and collides with another block of mass 3 kg moving along the same line in the opposite direction with velocity  $4m.s^{-1}$ .

(i) If the collision is perfectly elastic, determine velocities of both the blocks after their collision.

(ii) If coefficient of restitution is 0.6, determine velocities of both the blocks after their collision.



[Watch Video Solution](#)

38. A particle of mass  $2kg$  moving with a velocity  $5\hat{i}m/s$  collides head-on with another particle of mass  $3kg$  moving with a velocity  $-2\hat{i}m/s$ . After the collision the first particle has speed of  $1.6m/s$  in negative x-direction, Find

(a) velocity of the centre of mass after the collision,

(b) velocity of the second particle after the collision.

(c) coefficient of restitution.



[Watch Video Solution](#)

39. An object of mass  $m$  moving with speed  $u$  collides one dimensionally with another identical object at rest. Find their velocities after collision, if coefficient of restitution of collision is  $e$ .

[▶ Watch Video Solution](#)

40. Three identical balls, ball I, ball II and ball III are placed on a smooth floor on a straight line at the separation of  $10m$  between balls as shown in figure. Initially balls are stationary. But I is given velocity of  $10m/s$  towards ball II, collision between balls I and II is inelastic with coefficient of restitution  $0.5$  but collision between balls II and III is perfectly elastic. What is the time interval between two consecutive collisions between ball I and II?

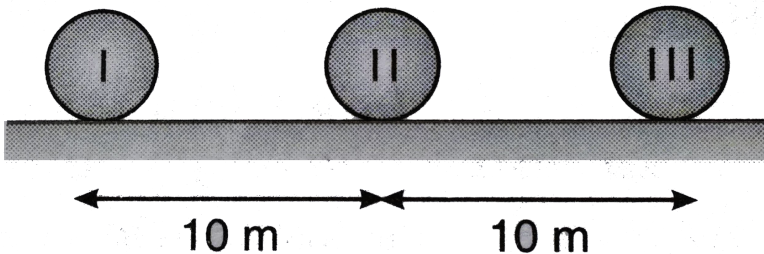



[Watch Video Solution](#)

## Check points

1. The position of centre of mass of system of particles at any moment does not depend on.

- A. masses of the particles
- B. internal forces on the particles
- C. position of the particles
- D. relative distance between the particles

**Answer: B**



[Watch Video Solution](#)

2. The center of mass of a system of two particles divides the distance between them.

A. in inverse ratio of square of masses of particles.

B. in direct ratio of square of masses of particles.

C. in inverse ratio of masses of particles.

D. in direct ratio of masses of particles.

**Answer: C**



**Watch Video Solution**

3. Two bodies of masses 1kg and 2kg are lying in xy plane at (-1,2) and (2,4) respectively. What are the coordinates of the center of mass?

A. (1,10/3)

B. (1,0)

C. (0,1)

D. None of these

**Answer: A**



[Watch Video Solution](#)

4. In a carbon monoxide molecule, the carbon and the oxygen atoms are separated by a distance  $1.2 \times 10^{-10} \text{ m}$ . The distance of the centre of mass from the carbon atom is

A.  $0.48 \times 10^{-10} \text{ m}$

B.  $0.51 \times 10^{-10} \text{ m}$

C.  $0.56 \times 10^{-10} \text{ m}$

D.  $0.68 \times 10^{-10} \text{ m}$

**Answer: D**



[Watch Video Solution](#)

5. Figure shows a composite system of two uniform rods of lengths as indicated. Then the coordinate of the center of mass of the system of

rods are

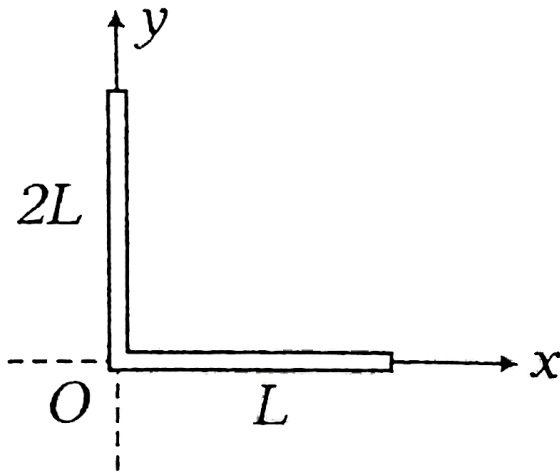

- A.  $\left(\frac{L}{2}, 2\frac{L}{3}\right)$
- B.  $\left(\frac{L}{4}, 2\frac{L}{3}\right)$
- C.  $\left(\frac{L}{6}, 2\frac{L}{3}\right)$
- D.  $\left(\frac{L}{6}, \frac{L}{3}\right)$

**Answer: C**



**Watch Video Solution**

6. All the particles of a body situated at distance  $d$  from the origin. The distance of the center of mass of the body from the origin is

A.  $= R$

B.  $\leq R$

C.  $> R$

D.  $\geq R$

**Answer: B**



[Watch Video Solution](#)

7. A uniform metre rod is bent into  $L$  shape with the bent arms at  $90^\circ$  to each other. The distance of the centre of mass from the bent point is

A. on the bisector of the angle,  $(1/\sqrt{2})\text{m}$  from vertex

B. on the bisector of angle,  $\left(\frac{1}{2\sqrt{2}}\right)\text{m}$  from vertex

C. on the bisector of the angle,  $1/2$  m from vertex



D. on the bisector of the angle,  $\left(\frac{1}{4\sqrt{2}}\right)$  m from vertex

Answer: D

 Watch Video Solution

8. Three point masses  $m_1$ ,  $m_2$  and  $m_3$  are placed at the corners of a thin massless rectangular sheet  $(1.2\text{ m} \times 1\text{ m})$  as shown. Center of mass will be located at the point.

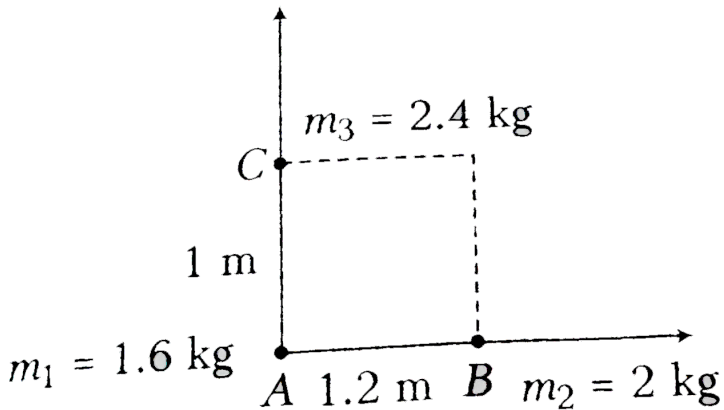

A.  $(0.8, 0.6)\text{ m}$

B.  $(0.6, 0.8)\text{ m}$

C.  $(0.4, 0.4)\text{ m}$

D.  $(0.5, 0.6)\text{m}$

Answer: C

 Watch Video Solution

9. Three rods of the same mass are placed as shown in the figure.

Calculate the coordinates of the centre of mass of the system.

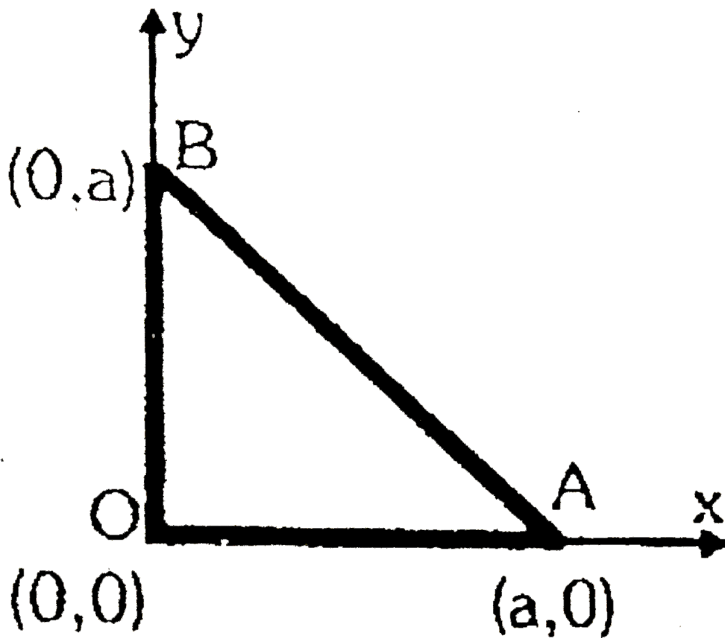

A.  $\left(\frac{a}{2}, \frac{a}{2}\right)$

B.  $\left(\frac{a}{\sqrt{2}}, \frac{a}{\sqrt{2}}\right)$

C.  $2a/3, 2a/3$

D.  $a/3, a/3$

**Answer: A**



**Watch Video Solution**

10. Centre of mass of three particles of masses  $1kg$ ,  $2kg$  and  $3kg$  lies at the point  $(1, 2, 3)$  and centre of mass of another system of particles  $3kg$  and  $2kg$  lies at the point  $(-1, 3, -2)$ . Where should we put a particle of mass  $5kg$  so that the centre of mass of entire system lies at the centre of mass of first system ?

A.  $(0,0,0)$

B.  $(1,3,2)$

C.  $(-1,2,3)$

D. None of these

Answer: A

 Watch Video Solution

11. Four particles of masses  $m_1 = 2m$ ,  $m_2 = 4m$ ,  $m_3 = m$  and  $m_4$  are placed at four corners of a square. What should be the value of  $m_4$  so that the centre of mass of all the four particles is exactly at the centre of the square?

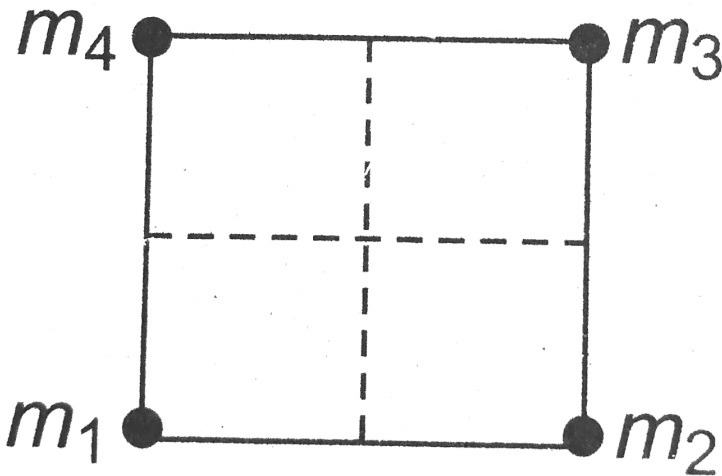

A.  $2m$

B.  $8m$

C. 6m

D. None of these

Answer: D

 [Watch Video Solution](#)

12. Four rods AB, BC, CD and DA have mass  $m, 2m, 3m$  and  $4m$  respectively.

The center of mass of all the four rods

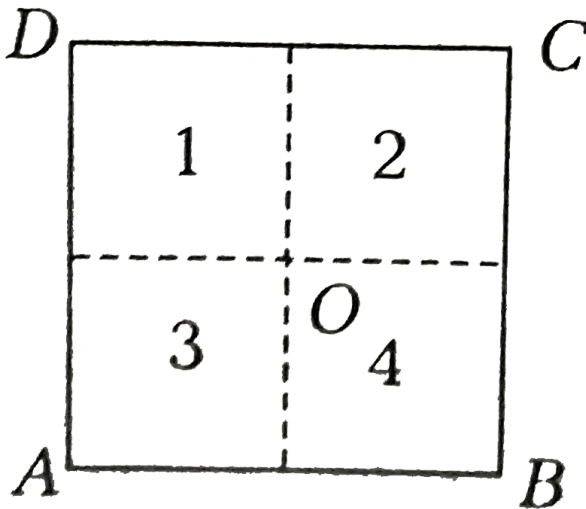

A. lie in region 1

B. lie in region 2

C. lie in region 3

D. lie at 0

**Answer: A**



**Watch Video Solution**

**13.** Three identical particles each of mass  $1\text{kg}$  are placed with their centres on a straight line. Their centres are marked  $A$ ,  $B$  and  $C$  respectively. The distance of centre of mass of the system from  $A$  is.

A.  $\frac{PQ + PR + QR}{3}$

B.  $\frac{PQ + PR}{3}$

C.  $\frac{PQ + QR}{3}$

D. None of the above

Answer: B

 Watch Video Solution

14. A square plate of side 20cm has uniform thickness and density. A circular part of diameter 8cm is cut out symmetrically and shown in figure. The position of center of mass of the remaining portion is

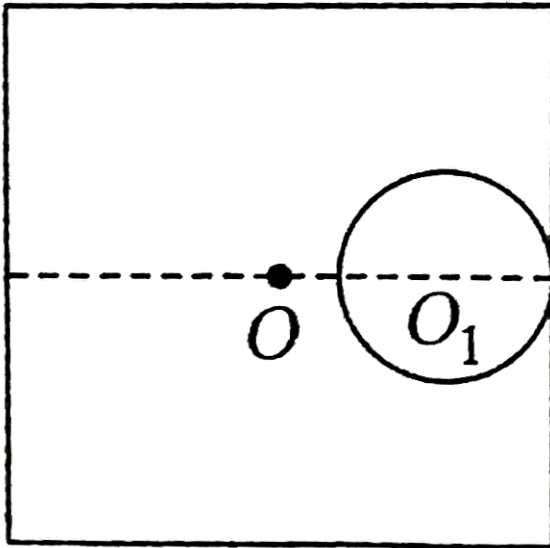

A. at  $O_1$

B. at O

C. 0.54 cm from O on the left hand side

D. None of the above

**Answer: D**



**Watch Video Solution**

15. A uniform metal disc of radius  $R$  is taken and out of it a disc of diameter  $R$  is cut-off from the end. The center of mass of the remaining part will be

A.  $\frac{R}{4}$  from the center

B.  $\frac{R}{3}$  from the center

C.  $\frac{R}{5}$  from the center

D.  $\frac{R}{6}$  from the center.

**Answer: D**





[Watch Video Solution](#)

16. A body at rest breaks into two pieces of equal masses. The parts will move

- A. in same direction
- B. along different lines
- C. in opposite directions with equal speeds
- D. in opposite direction with unequal speeds

**Answer: C**



[Watch Video Solution](#)

17. A body falling vertically downwards under gravity breaks in two parts of unequal masses. The centre of mass of the two parts taken together shifts horizontally towards

A. heavier piece

B. lighter piece

C. does not shift horizontally

D. depends on the vertical velocity at the time of breaking

**Answer: C**



**Watch Video Solution**

**18.** Two balls are thrown simultaneously in air. The acceleration of the centre of mass of the two balls while in air

A. depends on the direction of the motion of the balls.

B. depends on the masses of the two balls.

C. depends on the speeds of two balls

D. is equal to  $g$

**Answer: D**

 [Watch Video Solution](#)

19. Consider a system of two identical particles. One of the particles is at rest and the other has an acceleration. The centre of mass has an acceleration  $a$ . The centre of mass has an acceleration.

A. zero

B.  $\frac{1}{2}a$

C.  $a$

D.  $2a$

**Answer: B**

 [Watch Video Solution](#)

20. Two particles A and B initially at rest, move towards each other under mutual force of attraction. At the instant when the speed of A is  $V$  and the speed of B is  $2V$ , the speed of the centre of mass of the system is

A. zero

B.  $v$

C.  $1.5v$

D.  $3v$

**Answer: A**



[Watch Video Solution](#)

21. Two balls of equal mass are projected from a tower simultaneously with equal speeds. One at angle  $\theta$  above the horizontal and the other at the same angle  $\theta$  below the horizontal. The path of the center of mass of the two balls is

A. a vertical straight line

B. a horizontal straight line

C. a straight line at an angle  $\alpha (< 0)$  with horizontal

D. a parabola

**Answer: D**



[Watch Video Solution](#)

22. One projectile moving with velocity  $v$  in space, gets burst into 2 parts of masses in the ratio 1 : 3. The smaller part becomes stationary. What is the velocity of the other part?

A.  $4v$

B.  $v$

C.  $4v/3$

D.  $3v/4$

**Answer: C**



[Watch Video Solution](#)

23. A bomb of mass 9kg explodes into two pieces of masses 3 kg and 6kg.

The velocity of 3kg mass is  $16ms^{-1}$ . The velocity of 6kg mass is

A.  $4ms^{-1}$

B.  $8ms^{-1}$

C.  $16ms^{-1}$

D.  $32ms^{-1}$

**Answer: B**



[Watch Video Solution](#)

24. Two blocks of masses 10 kg and 4 kg are connected by a spring of negligible mass and placed on a frictionless horizontal surface. An impulse gives a velocity of  $14m/s$  to the heavier block in the direction of the lighter block. The velocity of the centre of mass is

A.  $30ms^{-1}$

B.  $20ms^{-1}$

C.  $10ms^{-1}$

D.  $5ms^{-1}$

**Answer: C**



**Watch Video Solution**

**25.** A ball kept in a closed box moves in the box making collisions with the walls. The box is kept on a smooth surface. The velocity of the centre of mass

A. of the box remains constant

B. of the box plus the ball system remains constant

C. of the ball remains constant

D. of the ball relative to the block remains constant

**Answer: B**

 [Watch Video Solution](#)

26. A meter stick is placed vertically at the origin on a frictionless surface. A gentle push in  $+x$  direction is given to the top most point of the rod. When it has fallen completely  $x$ -coordinate of center of rod is at

- A. origin
- B.  $-0.5m$
- C.  $-1m$
- D.  $+0.5m$

**Answer: A**

 [Watch Video Solution](#)

27. Two bodies having masses  $m_1$  and  $m_2$  and velocities  $v_1$  and  $v_2$  collide and form a composite system. If  $m_1v_1 + m_2v_2 = 0$  ( $m_1 \neq m_2$ ). The velocity of composite system will be



A.  $v_1 - v_2$

B.  $v_1 + v_2$

C.  $\frac{v_1 + v_2}{2}$

D. zero

**Answer: D**

 [Watch Video Solution](#)

**28.** Two particles of equal mass have coordinates  $(2m, 4m, 6m)$  and  $(6m, 2m, 8m)$ . Of these one particle has a velocity  $v_1 = (2i)ms^{-1}$  and another particle has a velocity  $v_2 = (2j)ms^{-1}$  at time  $t=0$ . The coordinate of their center of mass at time  $t=1s$  will be

A.  $(4m, 4m, 7m)$

B.  $(5m, 4m, 7m)$

C.  $(2m, 4m, 6m)$

D.  $(4m, 5m, 4m)$

**Answer: B**



[Watch Video Solution](#)

29. An isolated particle of mass  $m$  is moving in horizontal plane  $xy$  along the  $x$ -axis, at a certain height above the ground. It suddenly explodes into two fragment of masses  $m/4$  and  $3m/4$ . An instant later, the smaller fragment is at  $y = +15$  cm. The larger fragment at this instant is at

- A.  $y = -5$  m
- B.  $y = +20$  cm
- C.  $y = +5$  cm
- D.  $y = -20$  cm

**Answer: A**



[Watch Video Solution](#)

30. Blocks A and B are resting on a smooth horizontal surface given equal speeds of  $2\text{ms}^{-1}$  in opposite sense as shown in the figure.

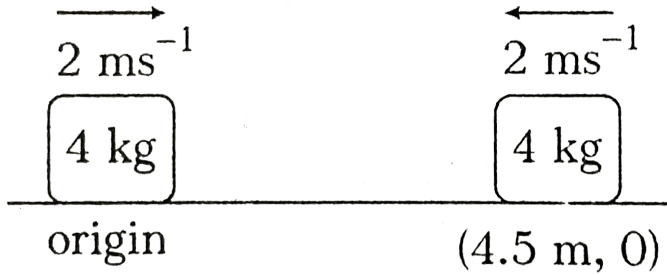

At  $t=0$ , the position of blocks are shown, then the coordinates of center of mass  $t=3\text{s}$  will be

- A. (1,0)
- B. (3,0)
- C. (5,0)
- D. (2.25,0)

**Answer: D**



[Watch Video Solution](#)

31. A man of mass  $m$  is standing on a plank of equal mass  $m$  resting on a smooth horizontal surface. The man starts moving on the plank with speed  $u$  relative to the plank. The speed of the man relative to the ground is

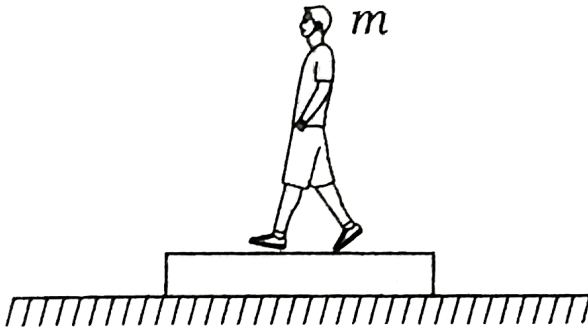

A.  $2u$

B.  $\frac{u}{2}$

C. zero

D.  $\frac{u}{4}$

**Answer: B**



**Watch Video Solution**

32. An object of mass  $3m$  splits into three equal fragments. Two fragments have velocities  $v\hat{j}$  and  $v\hat{i}$ . The velocity of the third fragment is

A.  $v(j - i)$

B.  $v(i - j)$

C.  $-v(i + j)$

D.  $\frac{v(i + j)}{\sqrt{2}}$

**Answer: C**



**Watch Video Solution**

33. A stationary bomb explodes into two parts of masses  $3\text{kg}$  and  $1\text{kg}$ . The total KE of the two parts after explosions is  $2400\text{J}$ . The KE of the smaller part is

A.  $600\text{J}$

B.  $1800\text{J}$

C. 1200J

D. 2160J

**Answer: B**



[Watch Video Solution](#)

**34.** A shell of mass  $m$  is moving horizontally with velocity  $v_0$  and collides with the wedge of mass  $M$  just above points A, as shown in the figure. As a consequences, wedge starts to move towards left and the shell returns with a velocity in  $xy$ -plane. The principle of conservation of momentum

can be applied for

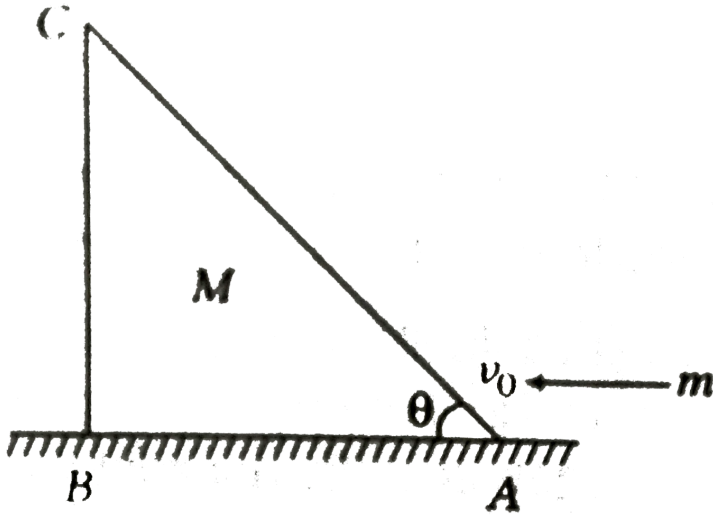

- A. system  $(m + M)$  along any direction
- B. system  $(m+M)$  along vertical
- C. system  $(m + M)$  horizontally
- D. None of the above

Answer: C



Watch Video Solution

35. A shell is fired from a cannon with a velocity  $v$  ( $m/sec.$ ) at an angle  $\theta$  with the horizontal direction. At the highest point in its path it explodes into two pieces of equal mass. One of the pieces retraces its path to the cannon and the speed (in  $m/sec.$ ) of the other piece immediately after the explosion is

A.  $3v \cos \theta$

B.  $2v \cos \theta$

C.  $\frac{3}{2}v \cos \theta$

D.  $\sqrt{\frac{3}{2}}v \cos \theta$

**Answer: A**



[Watch Video Solution](#)

36. In an elastic collision

A. Both momentum and KE are conserved



B. only momentum is conserved

C. only KE is conserved

D. Neither KE nor momentum is conserved

**Answer: A**



[Watch Video Solution](#)

37. If a body of mass  $m$  collides head on, elastically with velocity  $u$  with another identical body at rest. After collision velocity of the second body will be

A. zero

B.  $u$

C.  $2u$

D. data insufficient.

**Answer: B**



[Watch Video Solution](#)

38. A ball hits the floor and rebounds after an inelastic collision. In this case

- A. the momentum of the ball just after the collision is the same as the just before the collision
- B. the mechanical energy of the ball remains the same in the collision
- C. the total momentum of the ball and the earth is conserved
- D. the total energy of the ball and the earth is conserved

**Answer: C**



[Watch Video Solution](#)

39. A body of mass  $M_1$  collides elastically with another mass  $M_2$  at rest.

There is maximum transfer of energy when :

A.  $M_1 > M_2$

B.  $M_1 < M_2$

C.  $M_1 = M_2$

D. same for all values of  $M_1$  and  $M_2$

**Answer: C**

 [Watch Video Solution](#)

**40.** Two particles of mass  $m_A$  and  $m_B$  and their velocities are  $V_A$  and  $V_B$  respectively collides. After collision they interchanges their velocities, then ratio of  $\frac{m_A}{m_B}$  is

A.  $\frac{v_A}{v_B}$

B.  $\frac{v_B}{v_A}$

C.  $\frac{v_A + v_B}{v_B - v_A}$

D. 1

**Answer: D**



**Watch Video Solution**

41. Two perfectly elastic particles  $A$  and  $B$  of equal masses travelling along a line joining them with velocities  $15m/s$  and  $10m/s$  respectively collide. Their velocities after the elastic collision will be (in  $m/s$ ) respectively

A.  $10ms^{-1}$ ,  $10ms^{-1}$

B.  $15ms^{-1}$ ,  $15ms^{-1}$

C.  $10ms^{-1}$ ,  $15ms^{-1}$

D.  $15ms^{-1}$ ,  $10ms^{-1}$

**Answer: C**



**Watch Video Solution**

42. The collision of two balls of equal mass takes place at the origin of coordinates. Before collision, the components of velocities are ( $v_x = 50\text{cm}^{-1}$ ,  $v_y = 0$ ) and ( $v_x = -40\text{cm}^{-1}$  and  $v_y = 30\text{cms}^{-1}$ ). The first ball comes to rest after collision. The velocity (components  $v_x$  and  $v_y$  respectively) of the second ball are

A. 10 and  $30\text{cms}^{-1}$

B. 30 and  $10\text{cms}^{-1}$

C. 5 and  $15\text{cms}^{-1}$

D. 15 and  $5\text{cms}^{-1}$

**Answer: A**



[Watch Video Solution](#)

43. A mass of  $0.5\text{kg}$  moving with a speed of  $1.5\text{m/s}$  on a horizontal smooth surface, collides with a nearly weightless spring of force constant  $k = 50\text{N/m}$ . The maximum compression of the spring would be.

A. 0.12m

B. 1.5m

C. 0.5m

D. 0.15m

**Answer: D**



**Watch Video Solution**

**44.** Two perfectly elastic particles  $A$  and  $B$  of equal masses travelling along a line joining them with velocities  $15m/s$  and  $10m/s$  respectively collide. Their velocities after the elastic collision will be (in m/s) respectively

A.  $10ms^{-1}$ ,  $10ms^{-1}$

B.  $15ms^{-1}$ ,  $15ms^{-1}$

C.  $10ms^{-1}$ ,  $15ms^{-1}$

D.  $15ms^{-1}$ ,  $10ms^{-1}$

**Answer: C**



**Watch Video Solution**

45. A smooth sphere of mass  $M$  moving with velocity  $u$  directly collides elastically with another sphere of mass  $m$  at rest. After collision their final velocities are  $V$  and  $v$  respectively. The value of  $v$  is

A.  $\frac{2uM}{M}$

B.  $\left(2u \frac{M}{M}\right)$

C.  $2 \frac{u}{1 + \frac{m}{M}}$

D.  $\left(2 \frac{u}{1 + \frac{M}{m}}\right)$

**Answer: B**



**Watch Video Solution**

46. A body of mass  $m_1$  moving with a velocity  $3m/s$  collides with another body at rest of  $m_2$ . After collision the velocities of the two bodies are  $2m/s$  and  $5m/s$ , respectively, along the direction of motion of  $m_1$ . The ratio  $m_1/m_2$  is

A.  $\frac{5}{12}$

B. 5

C.  $\frac{1}{5}$

D.  $\frac{12}{5}$

**Answer: D**



**Watch Video Solution**

47. A body of mass  $m$  moving with velocity  $v$  collides head on with another body of mass  $2m$  which is initially at rest. The ratio of K.E. of colliding body before and after collision will be



A. 1:1

B. 2:1

C. 4:1

D. 9:1

**Answer: B**

 [Watch Video Solution](#)

**48.** The two diagrams show the situations before and after a collision between two spheres A and B of equal radii moving along the same straight line on a smooth horizontal surface. The coefficient of restitution

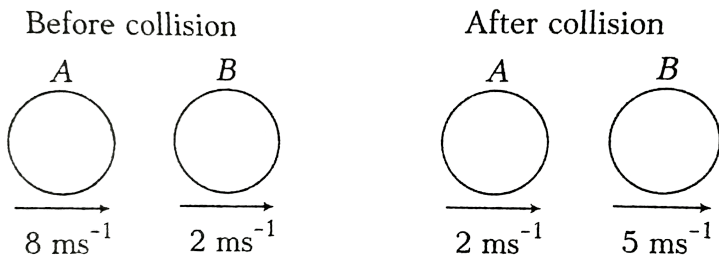

is  $e$

 [Watch Video Solution](#)

49. A block of mass  $m$  moving at speed  $v$  collides with another block of mass  $2m$  at rest. The lighter block comes to rest after the collision. Find the coefficient of restitution.

A.  $\frac{1}{2}$

B. 1

C.  $\frac{1}{3}$

D.  $\frac{1}{4}$

**Answer: A**



[Watch Video Solution](#)

50. Sphere A of mass ' $m$ ' moving with a constant velocity  $u$  hits another stationary sphere B of the same mass. If  $e$  is the coefficient of restitution, then ratio of velocities of the two spheres  $v_A : v_B$  after collision will be :

A.  $\frac{1 - e}{1 + e}$

B.  $\frac{1 + e}{1 - e}$

C.  $e + 1 \frac{)}{e - 1}$

D.  $\frac{e - 1}{e + 1}$

**Answer: B**



**Watch Video Solution**

## Taking it together

1. A bullet of mass  $a$  and velocity  $b$  is fired into a large block of mass  $c$ . The final velocity of the system is

A.  $\frac{M}{m + M} \cdot v$

B.  $\frac{m}{m + M} \cdot v$

C.  $\frac{m + M}{m} \cdot v$

D. None of these

**Answer: B**



**Watch Video Solution**

2. A bullet of mass 5 g is fired at a velocity of  $900\text{ms}^{-1}$  from a rifle of mass 2.5 kg. What is the recoil velocity of the rifle.?

A.  $0.9\text{ms}^{-1}$

B.  $180\text{ms}^{-1}$

C.  $900\text{ms}^{-1}$

D.  $1.8\text{ms}^{-1}$

**Answer: D**



**Watch Video Solution**

3. A body of mass  $a$  moving with a velocity  $b$  strikes a body of mass  $c$  and gets embedded into it. The velocity of the systems after collision is

A.  $\frac{a + c}{ab}$

B.  $\frac{ab}{a + c}$

C.  $\frac{a}{b + c}$

D.  $\frac{a}{a + b}$

**Answer: B**



**Watch Video Solution**

4. Two trains A and B are running in the same direction on the parallel rails such that A is faster than B. Packets of equal weight are transferred from A to B. What will happen due to this :

A. A will be accelerated but B will be retarded

B. B will be accelerated but A will be retarded

C. there will be no change in A but B will accelerated

D. there will be no change in B, but A will be accelerated

Answer: B

 [Watch Video Solution](#)

5. In a two block system an initial velocity  $v_0$  with respect to ground is given to block A

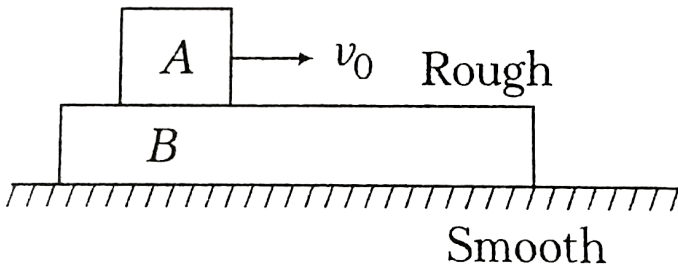

- A. the momentum of block A is not conserved
- B. the momentum of system of blocks A and B is conserved
- C. the increase in momentum of B is equal to the decrease in momentum of block A
- D. All of the above

Answer: D



[Watch Video Solution](#)

6. If the net external forces acting on the system of particles is zero, then which of the following may vary?

- A. Momentum of the system
- B. Velocity of center of mass
- C. Position of center of mass
- D. None of the above

**Answer: D**



[Watch Video Solution](#)

7. The bob  $A$  of a simple pendulum is released when the string makes an angle of  $45^\circ$  with the vertical. It hits another bob  $B$  of the same material

and same mass kept at rest on the table. If the collision is elastic, then

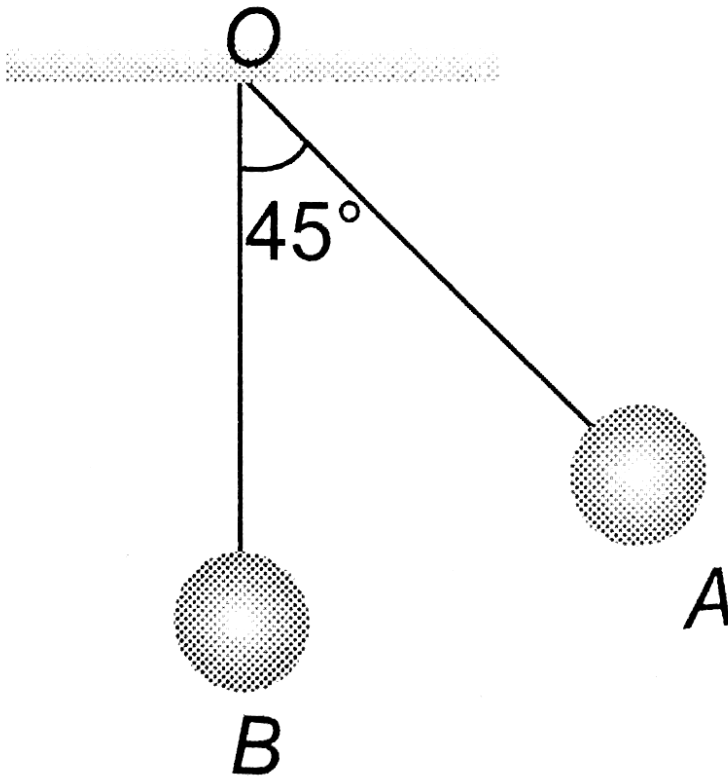

- A. Both A and B rise to the same height.
- B. Both A and B come to rest at B
- C. Both A and B move with the same velocity of A
- D. A comes to rest and B moves with the velocity of A

**Answer: D**





[Watch Video Solution](#)

8. Consider the following two statements:

A. linear momentum of the system remains constant.

B. Centre of mass of the system remains at rest

A. A implies B and B implies A

B. A does not imply B and B does not imply A.

C. A implies B but B does not imply A

D. B implies A but A does not imply B

**Answer: D**



[Watch Video Solution](#)

9. Consider the following two statements:

A. Linear momentum of a system of particles is zero.

B. Kinetic energy of a system of particles is zero.

A. A implies B and B implies A

B. A does not imply B and B does not imply A.

C. A implies B but B does not imply A

D. B implies A but A does not imply B

**Answer: D**



[Watch Video Solution](#)

10. A particle of mass  $m$  has momentum  $p$ . Its kinetic energy will be

A.  $mp$

B.  $p^2m$

C.  $\left(\frac{p^2}{m}\right)$

D.  $\frac{p^2}{2m}$

**Answer: D**



[Watch Video Solution](#)

11. A particle is projected from a point of an angle with the horizontal. At any instant  $t$ , if  $p$  is the linear momentum and  $E$  the kinetic energy, then which of the following graph is/are correct?

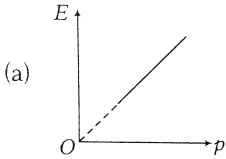

A.

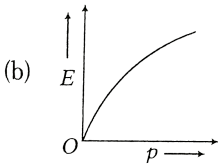

B.

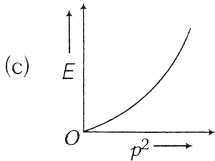

C.

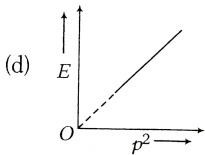

D.

**Answer: D**

 **Watch Video Solution**

12. A block of mass  $m$  at rest is acted upon by a force  $F$  for a time  $t$ . The kinetic energy of block after time  $t$  is

A.  $\frac{F^2 t^2}{m}$

B.  $\frac{F^2 t^2}{2m}$

C.  $\left( F^2 \frac{t^2}{3m} \right)$

D.  $\frac{Ft}{2m}$

**Answer: B**



[Watch Video Solution](#)

13. A 'T' shaped object with dimensions shown in the figure, is lying on a smooth floor. A force  $\vec{F}$  is applied at the point P parallel to AB, such that the object has only the translational motion without rotation. Find

the location of P with respect C.

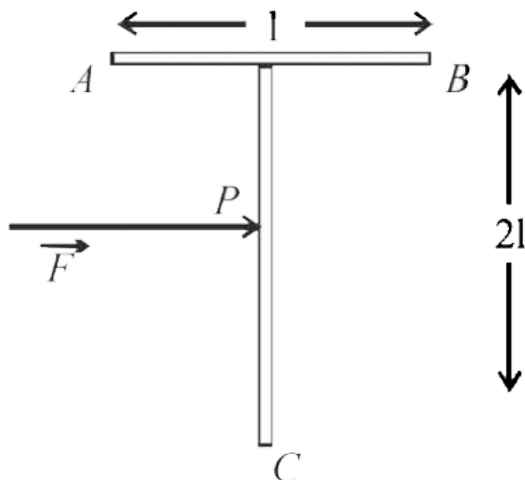

A.  $\left(\frac{4}{3}\right)l$

B.  $l$

C.  $\left(\frac{2}{3}\right)l$

D.  $\left(\frac{3}{2}\right)l$

**Answer: A**



**Watch Video Solution**

14. A cricket ball of mass  $150\text{g}$  moving with a speed of  $126\text{km/h}$  hits at the middle of the bat, held firmly at its position by the batsman. The ball moves straight back to the bowler after hitting the bat. Assuming that collision between ball and bat is completely elastic and the two remain in contact for  $0.001\text{s}$ , the force that the batsman had to apply to hold the bat firmly at its place would be

A.  $10.5\text{ N}$

B.  $21\text{ N}$

C.  $1.05 \times 10^4\text{ N}$

D.  $2.5 \times 10^4\text{ N}$

**Answer: C**



**Watch Video Solution**

15. Two identical ball bearings in contact with each other and resting on a frictionless table are hit head-on by another ball bearing of the same

mass moving initially with a speed  $V$  as shown in figure.

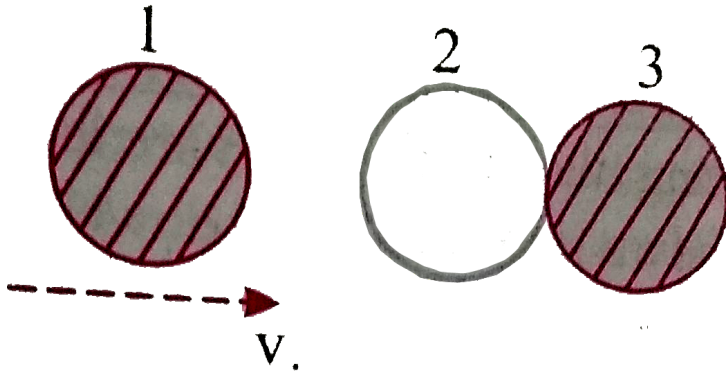

If the collision is elastic, which of the following (figure) is a possible result after collision ?

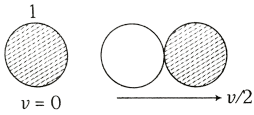

A.

(a)

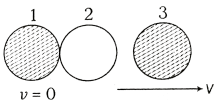

B.

(b)

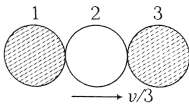

C.

(c)

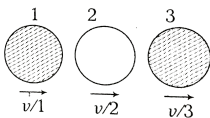

D.

(d)

**Answer: B**



[Watch Video Solution](#)

**16.** During inelastic collision between two bodies, which of the following quantities always remain conserved ?

- A. Total kinetic energy
- B. Total mechanical energy
- C. Total linear momentum
- D. Speed of each body

**Answer: C**



[Watch Video Solution](#)

**17.** Conservation of momentum in a collision between particles can be understood from



- A. Conservation of energy
- B. Newton's first law
- C. Newton's second law
- D. Both Newton's second and third law

**Answer: D**

 [Watch Video Solution](#)

**18.** For which of the following does the centre of mass lie outside the body ?

- A. A pencil
- B. A shotput
- C. A dice
- D. A bangle

**Answer: D**

19. Which of the following points is the likely position of the centre of mass of the system shown in Fig.

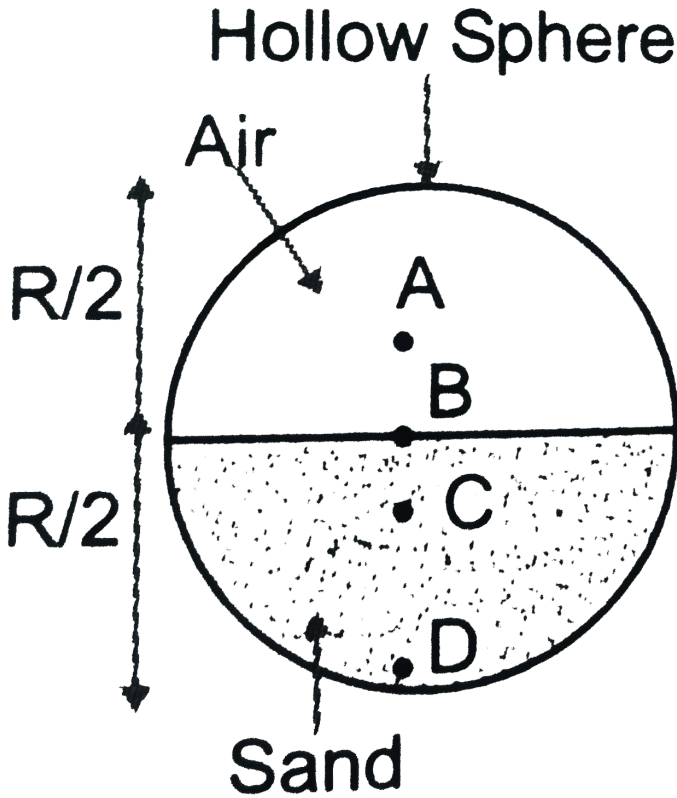

A. A

B. B

C. C

D. D

**Answer: C**



**Watch Video Solution**

20. A cannon ball is fired with a velocity  $200\text{ m / sec}$  at an angle of  $60^\circ$  with the horizontal. At the highest point of its flight it explodes into 3 equal fragments, one going vertically upwards with a velocity  $100\text{ m / sec}$ , the second one falling vertically downwards with a velocity  $100\text{ m / sec}$ . The third fragment will be moving with a velocity

A.  $100\text{ m s}^{-1}$  in the horizontal direction

B.  $300\text{ m s}^{-1}$  in the horizontal direction

C.  $300\text{ m s}^{-1}$  in a direction making an angle of  $60^\circ$  with the horizontal

D.  $200\text{ m s}^{-1}$  in a direction making an angle of  $60^\circ$  with the horizontal

**Answer: B**



Watch Video Solution

21. A particle of mass  $m$  moving with velocity  $u$  makes an elastic one-dimensional collision with a stationary particle of mass  $m$ . They come in contact for a very small time  $t_0$ . Their force of interaction increases from zero to  $F_0$  linearly in time  $0.5t_0$ , and decreases linearly to zero in further time  $0.5t_0$  as shown in figure. The magnitude of  $F_0$  is

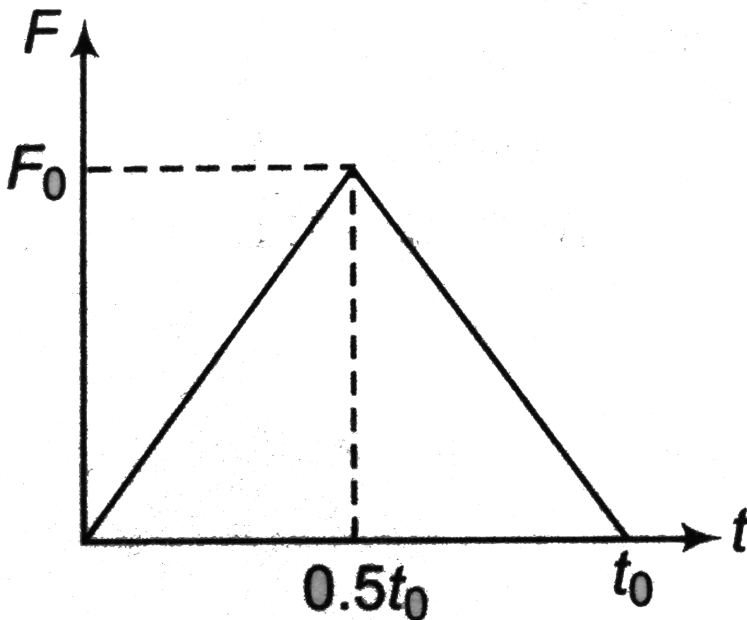

A.  $\frac{\mu}{T}$

B.  $\frac{2\mu}{T}$

C.  $\frac{\mu}{2T}$

D. None of these

**Answer: B**



[Watch Video Solution](#)

22. Two balls of equal mass have a head on collision with speed  $4ms^{-1}$  each travelling in opposite direction. If the coefficient's of resolution is  $\frac{1}{2}$ , the speed of each ball after impact will be

A.  $1ms^{-1}$

B.  $2ms^{-1}$

C.  $3ms^{-1}$

D. data insufficient.

**Answer: B**



[Watch Video Solution](#)

23. A metal ball falls from a height of 32 metre on a steel plate. If the coefficient of restitution is 0.5, to what height will the ball rise after second bounce

A. 2 m

B. 4m

C. 8m

D. 16 m

**Answer: A**



[Watch Video Solution](#)

24. A mass  $m$  with velocity  $u$  strikes a wall normally and returns with same speed. What is the magnitude of the change in momentum of the body when it returns.

A.  $4 mu$

B.  $\mu$

C.  $2\mu$

D. zero

Answer: C



Watch Video Solution

25. A projectile of mass  $m$  is fired with a velocity  $v$  from point P at an angle  $45^\circ$ . Neglecting air resistance, the magnitude of the change in momentum leaving the point P and arriving at Q is

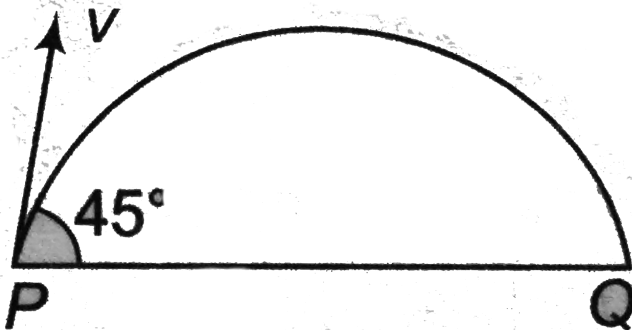

A. zero

B.  $m \frac{v}{\sqrt{2}}$

C.  $mv\sqrt{2}$

D.  $2mv$

**Answer: C**



**Watch Video Solution**

**26.** A machine gun fires a steady stream of bullets at the rate of  $n$  per minute into a stationary target in which the bullets get embedded. If each bullet has a mass  $m$  and arrives at the target with a velocity  $v$ , the average force on the target is

A.  $60 mnv$

B.  $\frac{60v}{mn}$

C.  $\frac{mnv}{60}$

D.  $\frac{mv}{60n}$



**Answer: C**



**Watch Video Solution**

27. 10,000 small balls, each weighing 1 gm , strike one square cm of area per second with a velocity 100 m/s in a normal direction and rebound with the same velocity. The value of pressure on the surface will be

A.  $2 \times 10^3 \text{ Nm}^{-2}$

B.

C.  $2 \times 10^5 \text{ Nm}^{-2}$

D.  $10^7 \text{ Nm}^{-2}$

**Answer: D**



**Watch Video Solution**

28. A block C of mass  $m$  is moving with velocity  $v_0$  and collides elastically with block A of mass  $m$  and connected to another block B of mass  $2m$  through spring constant  $k$ . What is  $k$  if  $x_0$  is compression of spring when velocity of A and B is same?

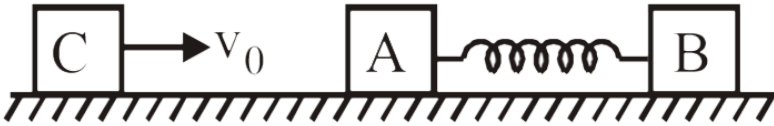

- A.  $\frac{mv_0^2}{x_0^2}$
- B.  $\frac{mv_0^2}{2x_0^2}$
- C.  $\frac{3mv_0^2}{2x_0^2}$
- D.  $\frac{2mv_0^2}{3x_0^2}$

**Answer: D**



**Watch Video Solution**

29. A bullet of mass  $m$  is fired into a block of wood of mass  $M$  which hangs on the end of pendulum and gets embedded into it. When the bullet strikes with maximum rise  $R$ . Then, the velocity of the bullet is given by

A.  $\frac{M}{m + M} (\sqrt{2gR})$

B.  $\frac{M + m}{m} \sqrt{2gR}$

C.  $\left(\frac{M}{m}\right) \sqrt{2gR}$

D. None of these

**Answer: B**



**Watch Video Solution**

30. A particle of mass  $m$  moving with a speed  $v$  hits elastically another stationary particle of mass  $2m$  on a smooth horizontal circular tube of radius  $r$ . Find the time when the next collision will take place?

A.  $\frac{2\pi r}{v}$

B.  $\frac{4\pi r}{v}$

C.  $\frac{3\pi r}{2v}$

D.  $\pi r \frac{)}{v}$

**Answer: A**



**Watch Video Solution**

31. A bullet of mass  $20g$  and moving with  $600\frac{m}{s}$  collides with a block of mass  $4kg$  hanging with the string. What is the velocity of bullet when it comes out of block, if block rises to height  $0.2m$  after collision?

A.  $200ms^{-1}$

B.  $150ms^{-1}$

C.  $400ms^{-1}$

D.  $300ms^{-1}$

**Answer: A**



Watch Video Solution

32. A bomb of  $1\text{kg}$  is thrown vertically up with speed  $100\text{m/s}$ . After 5 seconds it explodes into two parts. One part of mass  $400\text{gm}$  goes down with speed  $25\text{m/s}$ . What will happen to the other part just after explosion .

- A.  $100\text{ms}^{-1}$  upward
- B.  $600\text{ms}^{-1}$  upward
- C.  $100\text{ms}^{-1}$  downward
- D.  $300\text{ms}^{-1}$  upward

**Answer: A**



Watch Video Solution

33. A ball after freely falling from a height of  $4.9\text{m}$  strikes a horizontal plane. If the coefficient of restitution is  $\frac{3}{4}$ , the ball will strike second time

with the plane after

A. 1s

B. 1.5 s

C. 2 s

D. 3 s

**Answer: B**



[Watch Video Solution](#)

**34.** A disc of mass 10 g is kept floating horizontally by throwing 10 marbles per second against it from below . If mass of each marble is 5 g Calculate the velocity with which marbles are striking the disc . Assume that marbles strike the disc . Normally and rebound downwards with the same speed.

A.  $2.98ms^{-1}$

B.  $0.98ms^{-1}$

C.  $0.49ms^{-1}$

D.  $1.96ms^{-1}$

**Answer: B**



[Watch Video Solution](#)

35. A machine gun fires a bullet of mass 40 g with a velocity  $1200ms^{-1}$ .

The man holding it can exert a maximum force of 144 N on the gun. How many bullets can be fire per second at the most?

A. One

B. Four

C. Two

D. Three

**Answer: D**



[Watch Video Solution](#)

36. A straight rod of length  $L$  has one of its end at the origin and the other at  $X = L$ . If the mass per unit length of the rod is given by  $Ax$  where  $A$  is constant, where is its centre of mass?

A.  $\frac{L}{3}$

B.  $\frac{L}{2}$

C.  $\frac{2L}{3}$

D.  $\frac{3L}{4}$

**Answer: C**



**Watch Video Solution**

37. In a one-dimensional collision between two identical particles. A and B, B is stationary and A has momentum  $p$  before impact. During impact, B gives an impulse  $J$  to A. Find the coefficient of restitution between A and B?



A.  $\frac{2J}{p} - 1$

B.  $\frac{2J}{p} + 1$

C.  $\left(\frac{J}{p}\right) + 1$

D.  $\left(\frac{J}{p}\right) - 1$

**Answer: A**



**Watch Video Solution**

**38.** A partical of mass ' $m$ ' moving with a velocity  $(3\hat{i} + 2\hat{j})m/s$  collides with statinary mass ' $M$ ' and finally ' $m$ ' moves with a velocity  $(-2\hat{i} + \hat{j})m/s$  if  $\frac{m}{M} = \frac{1}{13}$  the velocity of the  $M$  after collision is?

A. the impulse is  $\pm m(5\hat{i} + \hat{j})$

B. the velocity of the M is  $\left(\frac{1}{13}\right)(5\hat{i} + \hat{j})$

C. Both (a) and (b) are wrong

D. Both (a) and (b) are correct

**Answer: D**



[Watch Video Solution](#)

39. A mass of 10 gm moving with a velocity of 100 cm / s strikes a pendulum bob of mass 10 gm . The two masses stick together. The maximum height reached by the system now is ( $g = 10m / s^2$ )

A. 7.5 cm

B. 5cm

C. 2.5 cm

D. 1.25cm

**Answer: D**



[Watch Video Solution](#)

40. Both the blocks as shown in figure are given together a horizontal velocity towards right. The acceleration of the centre of mass of the system of block is ( $m_A = 2m_B = 2kg$ ).

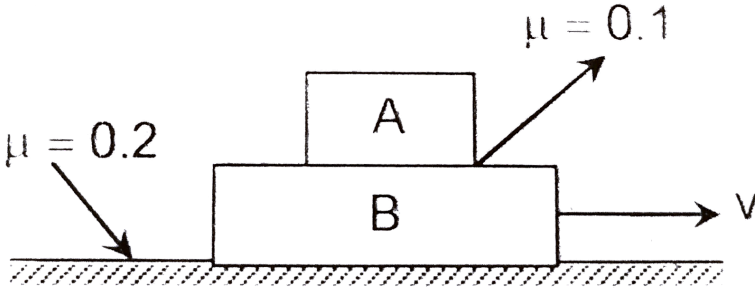

A. Zero

B.  $\left(\frac{5}{3}\right)ms^{-2}$

C.  $\left(\frac{7}{3}\right)ms^{-2}$

D.  $2ms^{-1}$

Answer: D



Watch Video Solution

41. A ladder is leaned against a smooth wall and it is allowed to slip on a frictionless floor. Which figure represents the track of its centre of mass ?

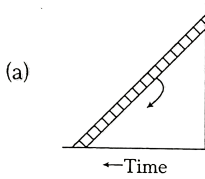

A.

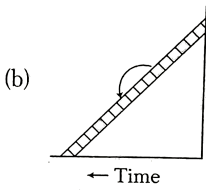

B.

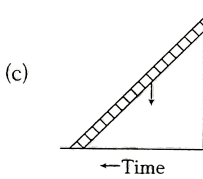

C.

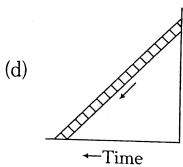

D.

**Answer: A**



**Watch Video Solution**

42. A circular plate of diameter  $d$  is kept in contact with a square plate of edge  $d$  as shown in figure. The density of the material and the thickness are same

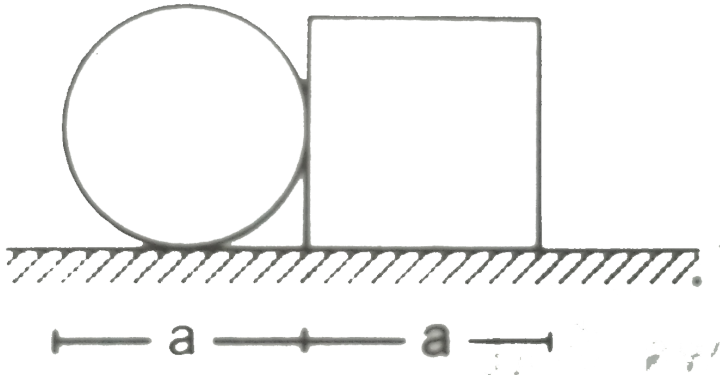

. Everywhere.

The centre of mass of the composite system will be

- A. inside the circular plate
- B. inside the square plate
- C. at the point of contact
- D. outside the system

**Answer: B**

[Watch Video Solution](#)

43. A circular ring of mass 6kg and radius  $a$  is placed such that its center of mass lies at the origin. Two particles of masses 2 kg each are placed at the intersecting points of the circle with positive X-axis and positive Y-axis. Then, the angle made by the position vector of center of mass of entire system with X-axis is

A.  $45^\circ$

B.  $60^\circ$

C.  $\tan^{-1}\left(\frac{4}{5}\right)$

D.  $30^\circ$

**Answer: A**



[Watch Video Solution](#)

44. In a gravity free space, man of mass  $M$  standing at a height  $h$  above the floor, throws a ball of mass  $m$  straight down with a speed  $u$ . When the ball reaches the floor, the distance of the man above the floor will be.

A.  $h\left(1 + \left(\frac{m}{M}\right)\right)$

B.  $\left(1 + \left(\frac{M}{m}\right)\right)h$

C.  $h$

D.  $\left(\frac{m}{M}\right)h$

**Answer: A**



**Watch Video Solution**

**45.** A ball falls freely from a height of 45m. When the ball is at a height of 25m, it explodes into two equal pieces. One of them moves horizontally with a speed of  $10ms^{-1}$ . The distance between the two pieces on the ground is

A. 20 m

B. 30 m

C. 40 m

D. 60 m

**Answer: A**



[Watch Video Solution](#)

**46.** Two blocks of masses 10 kg and 30 kg are placed along a vertical line. The first block is raised through a height of 7 cm. By what distance should the second mass be moved to raise the centre of mass by 1 cm?

- A. 2 cm upward
- B. 1 cm upward
- C. 2cm downward
- D. 1 cm downward

**Answer: D**



[Watch Video Solution](#)



47. In a free space a rifle on mass  $M$  shoots a bullet of mass  $m$  at a stationary block of mass  $M$  distance  $D$  away from it . When the bullet has moved through a distance  $d$  towards the block the centre of mass of the bullet – block system is at a distance of :

- A.  $\frac{(D - d)m}{M + m}$  from the bullet
- B.  $\frac{md + MD}{M + m}$  from the block
- C.  $\frac{2md + MD}{M + m}$  from the block
- D.  $\frac{(D - d)M}{M + m}$  from the bullet

**Answer: D**



[Watch Video Solution](#)

48. A cracker is thrown into air with a velocity of  $10m/s$  at an angle of  $45^\circ$  with the vertical. When it is at a height of  $0.5m$  from the ground, it explodes into a number of pieces which follow different parabolic paths.

What is the velocity of centre of mass, when it is at a height of  $1m$  from the ground? ( $g = 10m/s^2$ )

A.  $4\sqrt{5}ms^{-1}$

B.  $2\sqrt{5}ms^{-1}$

C.  $5\sqrt{4}ms^{-1}$

D.  $5ms^{-1}$

**Answer: A**



**Watch Video Solution**

**49.** A 2 kg block of wood rests on a long table top. A 5 g bullet moving horizontally with a speed of  $150ms^{-1}$  is shot into the block and sticks to it. The block then slides 2.7m along the table top and comes to a stop. The force of friction between the block and the table is

A. 0.052 N

B. 3.63 N

C. 2.50 N

D. 1.04 N

**Answer: A**



[Watch Video Solution](#)

50. If kinetic energy of a body is increased by 300%, then percentage change in momentum will be

A. 1

B. 1.5

C.  $\sqrt{300} \%$

D. 175 %

**Answer: A**



[Watch Video Solution](#)

51. If the linear momentum is increased by 50%, then KE will be increased by :

A. 0.5

B. 1

C. 1.25

D. 0.25

**Answer: C**



[Watch Video Solution](#)

52. If the kinetic energy of a body increases by 0.1 % the percent increase of its momentum will be

A. 0.05 %

B. 0.1 %

C. 1.0 %

D. 10 %

**Answer: A**



[Watch Video Solution](#)

53. A bullet moving with a speed of  $100ms^{-1}$  can just penetrate into two planks of equal thickness. Then the number of such planks, if speed is doubled will be .

A. 4

B. 8

C. 6

D. 10

**Answer: C**



[Watch Video Solution](#)

54. A ball is projected vertically down with an initial velocity from a height of  $20m$  onto a horizontal floor. During the impact it loses  $50\%$  of its energy and rebounds to the same height. The initial velocity of its projection is

A.  $20ms^{-1}$

B.  $15ms^{-1}$

C.  $10ms^{-1}$

D.  $5ms^{-1}$

**Answer: A**



[Watch Video Solution](#)

55. A ball of mass  $m$  is released from the top of an inclined plane of inclination  $\theta$  as shown. It strikes a rigid surface at a distance  $\frac{3l}{4}$  from

top elastically. Impulse imparted to ball by the rigid surface is

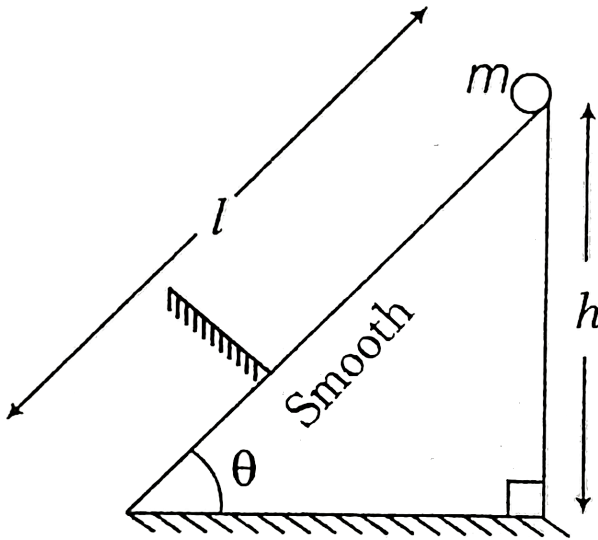

A.  $m\sqrt{\frac{3}{2}gh}$

B.  $m\sqrt{3gh}$

C.  $2m\sqrt{3gh}$

D.  $m\sqrt{6gh}$

**Answer: D**



**Watch Video Solution**

56. Two identical blocks  $A$  and  $B$ , each of mass  $m$  resting on smooth floor are connected by a light spring of natural length  $L$  and spring constant  $k$ , with the spring at its natural length. A third identical block  $C$  (mass  $m$ ) moving with a speed  $v$  along the line joining  $A$  and  $B$  collides with  $A$ . The maximum compression in the spring is

A.  $v\sqrt{\frac{m}{2k}}$

B.  $m\sqrt{\frac{v}{2k}}$

C.  $\sqrt{\frac{mv}{k}}$

D.  $\frac{mv}{2k}$

**Answer: A**



**Watch Video Solution**

57. A man of mass  $M$  stands at one end of a stationary plank of length  $L$ , lying on a smooth surface. The man walks to the other end of the plank. If



the mass of the plank is  $M/3$ , the distance that the man moves relative to the ground is

A.  $\frac{3L}{4}$

B.  $\frac{L}{4}$

C.  $\frac{4L}{5}$

D.  $\frac{L}{3}$

**Answer: B**



**Watch Video Solution**

**58.** A man of mass  $m$  moves with a constant speed on a plank of mass  $M$  and length  $l$  kept initially at rest on a frictionless horizontal surface, from one end to the other in time  $t$ . The speed of the plank relative to ground while man is moving, is

A.  $\frac{l}{t} \left( \frac{M}{m} \right)$

B.  $\frac{l}{t} \left( \frac{m}{m + M} \right)$

C.  $\frac{l}{t} \left( \frac{M}{M+m} \right)$

D. None of these

**Answer: B**



**Watch Video Solution**

59. At high altitude , a body explodes at rest into two equal fragments with one fragment receiving horizontal velocity of  $10m/s$ . Time taken by the two radius vectors connecting of explosion to fragments to make  $90^\circ$  is

A. 0.5 s

B. 4 s

C. 2 s

D. 1 s

**Answer: D**



**Watch Video Solution**

60. A particle A of mass  $m$  initially at rest slides down a height of  $1.25\text{ m}$  on a frictionless ramp, collides with and sticks to an identical particles B of mass  $m$  at rest as shown in the figure.

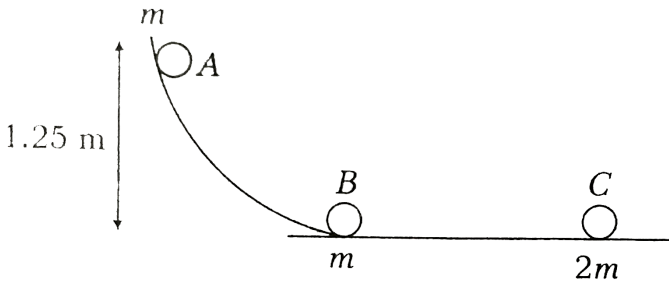

Then, particles A and B together collide elastically with particle G of mass  $2m$  at rest. The speed of particle G after the collision with combined body (A+B) would be (Take,  $g = 10\text{ms}^{-2}$ )

- A.  $2\text{ms}^{-1}$
- B.  $1.25\text{ms}^{-1}$
- C.  $2.5\text{ms}^{-1}$
- D.  $5\text{ms}^{-1}$

**Answer: C**



Watch Video Solution

61. A pendulum consists of a wooden bob of mass  $m$  and length  $l$ . A bullet of mass  $m_1$  is fired towards the pendulum with a speed  $v_1$ . The bullet emerges out of the bob with a speed of  $(v_1)/3$  and the bob just completes motion along a vertical circle, then  $v_1$  is

A.  $\frac{m}{m_1} \sqrt{5gl}$

B.  $\frac{3m}{2m_1} \sqrt{5gl}$

C.  $\frac{2}{3} \left( \frac{m}{m_1} \right) \sqrt{5gl}$

D.  $\left( \frac{m_1}{m} \right) \sqrt{gl}$

Answer: B



Watch Video Solution

62. Two blocks of mass  $m$  and  $2m$  are kept on a smooth horizontal surface. They are connected by an ideal spring of force constant  $k$ .

Initially the spring is unstretched. A constant force is applied to the heavier block in the direction shown in figure. Suppose at time  $t$  displacement of smaller block is  $x_1$  then displacement of the heavier block at this moment would be

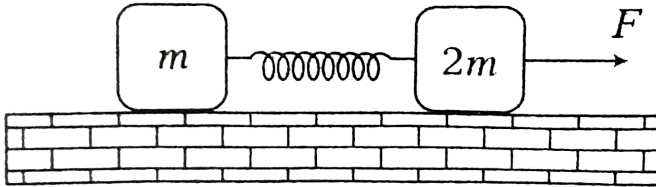

- A.  $\frac{x}{2}$
- B.  $\frac{Ft^2}{6m} + \frac{x}{3}$
- C.  $\frac{x}{3}$
- D.  $\frac{Ft^2}{4m} - \frac{x}{2}$

**Answer: D**



**Watch Video Solution**

63. Three identical blocks A, B and C are placed on horizontal frictionless surface. The blocks B and C are at rest. But A is approaching towards B with a speed of  $10\text{ms}^{-1}$

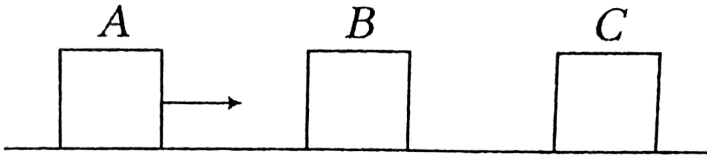

The coefficient of restitution for all collision is 0.5. The speed of the block C just after collision is

A.  $5.6\text{ms}^{-1}$

B.  $6.4\text{ms}^{-1}$

C.  $3.2\text{ms}^{-1}$

D.  $4.6\text{ms}^{-1}$

**Answer: A**



**Watch Video Solution**

64. You are supplied with three identical rods of same length and mass. If the length of each rod is  $2\pi$ . Two of them are converted into rings and then placed over the third rod as shown in figure. If point A is considered as origin of the coordinate system the coordinate of the center of mass will be (you may assume AB as x-axis of the coordinate system).

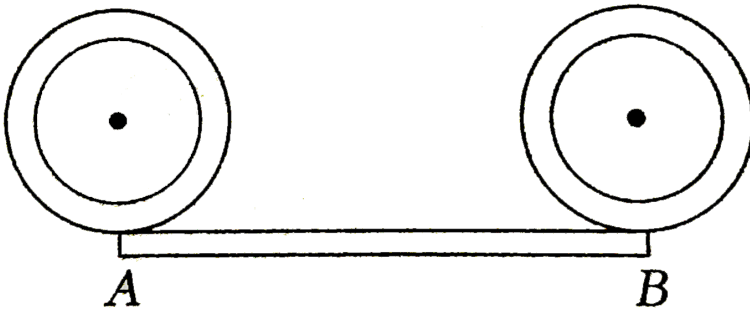

- A.  $\left(\frac{\pi}{2}, \frac{1}{3}\right)$
- B.  $\left(\frac{\pi}{2}, \frac{2}{3}\right)$
- C.  $\left(\pi, \frac{1}{3}\right)$
- D.  $\left(\pi, \frac{2}{3}\right)$

Answer: D



Watch Video Solution

65. An object comprises of a uniform ring of radius  $R$  and its uniform chord  $AB$  (not necessarily made of the same material) as shown. Which of the following can not be the centre of mass of object

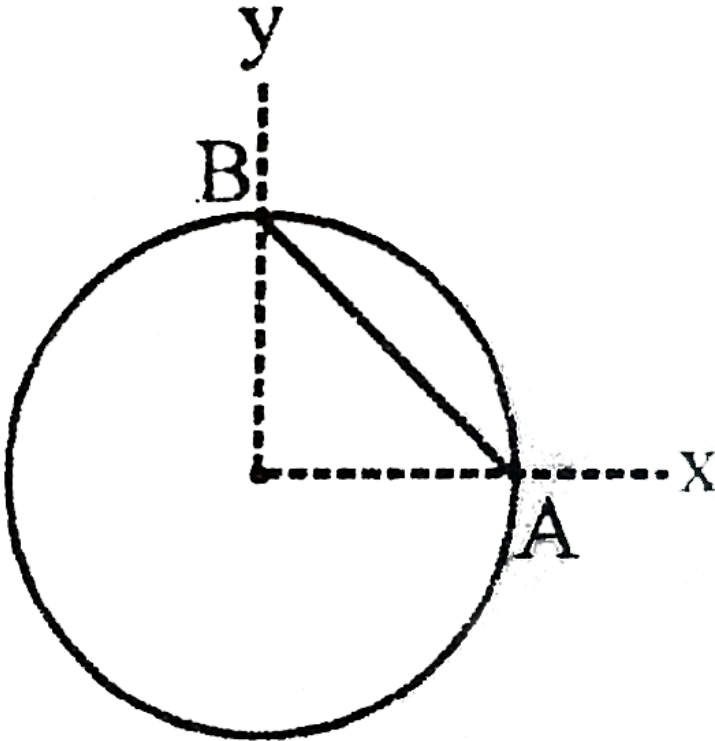

A.  $\left(\frac{R}{3}, \frac{R}{3}\right)$

B.  $\frac{R}{\sqrt{2}}, \frac{R}{\sqrt{2}}$



C.  $\left(\frac{R}{4}, \frac{R}{4}\right)$

D. None of these

**Answer: D**

 [Watch Video Solution](#)

**66.** A uniform circular disc of radius  $a$  is taken. A circular portion of radius  $b$  has been removed from it as shown in the figure. If the center of hole is at a distance  $c$  from the center of the disc, the distance  $x_2$  of the center of mass of the remaining part from the initial center of mass  $O$  is given by

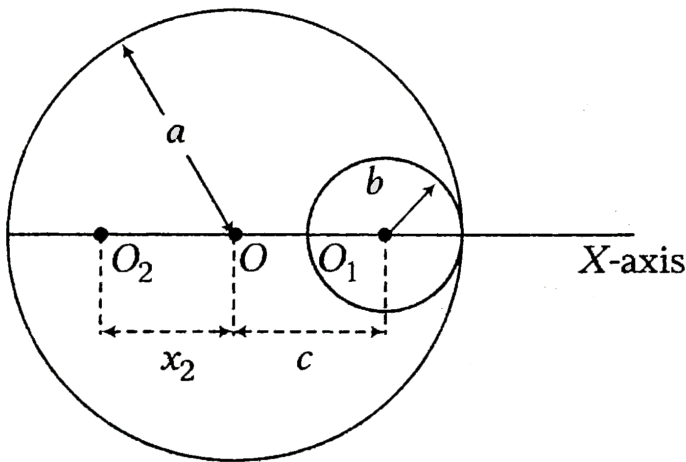

A.  $\frac{\pi b^2}{a^2 - c^2}$

B.  $\frac{cb^2}{a^2 - b^2}$

C.  $\frac{\pi c^2}{a^2 - b^2}$

D.  $\frac{ca^2}{(c^2 - b^2)}$

**Answer: B**



**Watch Video Solution**

67. From a circular disc of radius  $R$ , a square is cut out with a radius as its diagonal. The center of mass of remaining portion is at a distance from the center)

A.  $\frac{R}{4\pi - 2}$

B.  $\frac{R}{2\pi}$

C.  $\frac{R}{\pi - 2}$

D.  $\frac{R}{2\pi - 2}$

**Answer: A**

[Watch Video Solution](#)

68. A particle falls from a height  $h$  upon a fixed horizontal plane and rebounds. If  $e$  is the coefficient of restitution, the total distance travelled before rebounding has stopped is

A.  $h \left( \frac{1 + e^2}{1 - e^2} \right)$

B.  $h \left( \frac{1 - e^2}{1 + e^2} \right)$

C.  $\frac{h}{2} \left( \frac{1 - e^2}{1 + e^2} \right)$

D.  $\frac{h}{2} \left( \frac{1 + e^2}{1 - e^2} \right)$

**Answer: A**

[Watch Video Solution](#)

69. A train of mass  $M$  is moving on a circular track of radius  $R$  with constant speed  $v$ . The length of the train is half of the perimeter of the track. The linear momentum of the train will be

A.  $\pi Mv$

B.  $\frac{2Mv}{\pi}$

C.  $\frac{\pi Mv}{2}$

D.  $Mv$

**Answer: B**



**Watch Video Solution**

**70.** A block A of mass  $M$  moving with speed  $u$  collides elastically with block B of mass  $m$  which is connected to block C of mass  $m$  with a spring.



When the compression in spring is maximum, the velocity of block C with respect to block A is (Neglect the friction everywhere)

A. zero

B.  $\left(\frac{M}{M+m}\right)u$

C.  $\left(\frac{m}{M+m}\right)u$

D.  $\left(\frac{m}{M}\right)u$

Answer: B

 [View Text Solution](#)

71.  $n$  elastic balls are placed at rest on a smooth horizontal plane which is circular at the ends with radius  $r$  as shown in the figure. The masses of the balls are  $m, \frac{m}{2}, \frac{m}{2^2}, \dots, \frac{m}{2^{n-1}}$  respectively. What is the minimum velocity which should be imparted to the first ball of mass  $m$  such that  $n^{\text{th}}$  ball completes the vertical circle



A.  $\left(\frac{3}{4}\right)^{n-1} \sqrt{5gr}$

B.  $\left(\frac{4}{3}\right)^{n-1} \sqrt{5gr}$

C.  $\left(\frac{3}{2}\right)^{n-1} \sqrt{5gr}$

D.  $\left(\frac{2}{3}\right)^{n-1} \sqrt{5gr}$

**Answer: A**



**Watch Video Solution**

72. A small ball rolls off the top landing of a staircase. It strikes the mid point of the first step and then mid point of the second step. The steps are smooth & identical in height & width. The coefficient of restitution between the ball & the first step is :

A. 1

B.  $\frac{3}{4}$

C.  $\frac{1}{2}$

D.  $\frac{1}{4}$

**Answer: B**



**Watch Video Solution**

[Watch Video Solution](#)

73. A girl throws a ball with an initial velocity  $v$  at an angle  $45^\circ$ . The ball strikes a smooth vertical wall at a horizontal distance  $d$  from the girl and after rebound returns to her hands. What is the coefficient of restitution between wall and ball ? ( $v^2 > dg$ )

A.  $v^2 - gd$ )

B.  $\frac{gd}{v^2 - gd}$

C.  $\frac{gd}{v^2}$

D.  $\frac{v^2}{gd}$

**Answer: B**

[Watch Video Solution](#)

Assertion and reason

1. These questions consists of two statements each printed as Assertion and Reason. While answering these question you are required to choose any one of the following five responses.

Reason: For inelastic collision,  $0 \leq e < 1$ . Hence, the magnitude of relative velocity of separation after collision is less than relative velocity of approach before collision.

- A. If both Assertion and Reason are correct and Reason is the correct explanation of Assertion.
- B. If both Assertion and Reason are correct but Reason is not the correct explanation of Assertion.
- C. If Assertion is true but Reason is false.
- D. If Assertion is false but Reason is true.

**Answer: D**



[Watch Video Solution](#)



2. These questions consists of two statements each printed as Assertion and Reason. While answering these question you are required to choose any one of the following five responses.

Reason: In an eleastic collision, the linear momentum of the system is conserved.

A. If both Assertion and Reason are correct and Reason is the correct explanation of Assertion.

B. If both Assertion and Reason are correct but Reason is not the correct explanation of Assertion.

C. If Assertion is true but Reason is false.

D. If Assertion is false but Reason is true.

**Answer: B**



[View Text Solution](#)

3. Assertion: A given force applied in turn to a number of different masses may cause the same rate of change in momentum in each but not the same acceleration to all.

Reason:  $F = \frac{dp}{dt}$  and  $a = \frac{F}{m}$

- A. If both Assertion and Reason are correct and Reason is the correct explanation of Assertion.
- B. If both Assertion and Reason are correct but Reason is not the correct explanation of Assertion.
- C. If Assertion is true but Reason is false.
- D. If Assertion is false but Reason is true.

**Answer: A**



**Watch Video Solution**

4. Assertion: In inelastic collision, linear momentum of system does not remain constant during collision. But before collision and after collision, it is constant.

Reason: In elastic collision, momentum remains constant during collision also.

- A. If both Assertion and Reason are correct and Reason is the correct explanation of Assertion.
- B. If both Assertion and Reason are correct but Reason is not the correct explanation of Assertion.
- C. If Assertion is true but Reason is false.
- D. If Assertion is false but Reason is true.

**Answer: B**



**Watch Video Solution**

5. Assertion: Two spherical bodies of mass ratio 1 : 2 travel towards each other (starting from rest) under the action of their mutual gravitational attraction. Then, the ratio of their kinetic energies at any instant is 2 : 1

Reason: At any instant their momenta are same.

- A. If both Assertion and Reason are correct and Reason is the correct explanation of Assertion.
- B. If both Assertion and Reason are correct but Reason is not the correct explanation of Assertion.
- C. If Assertion is true but Reason is false.
- D. If Assertion is false but Reason is true.

**Answer: D**



[Watch Video Solution](#)

6. Assertion: Center of mass and center of gravity of a body will coincide on moon.

Reason: There is no gravity on moon.

- A. If both Assertion and Reason are correct and Reason is the correct explanation of Assertion.
- B. If both Assertion and Reason are correct but Reason is not the correct explanation of Assertion.
- C. If Assertion is true but Reason is false.
- D. If Assertion is false but Reason is true.

**Answer: B**



[Watch Video Solution](#)

7. Assertion: A projectile gets exploded at its highest point. All the piece get only horizontal velocities.

Reason: The weight of the projectile is the external force for projectile.

- A. If both Assertion and Reason are correct and Reason is the correct explanation of Assertion.
- B. If both Assertion and Reason are correct but Reason is not the correct explanation of Assertion.
- C. If Assertion is true but Reason is false.
- D. If Assertion is false but Reason is true.

**Answer: D**



[Watch Video Solution](#)

**8. Assertion:** If a projectile explodes in mid air, linear momentum of center of mass of different fragments remains constant.

- A. If both Assertion and Reason are correct and Reason is the correct explanation of Assertion.

B. If both Assertion and Reason are correct but Reason is not the correct explanation of Assertion.

C. If Assertion is true but Reason is false.

D. If Assertion is false but Reason is true.

**Answer: A**

 [View Text Solution](#)

**9.** Assertion: When a body dropped from a height explodes in mid air, its center of mass keeps moving in vertically downward directions.

Reason: Explosion occurs under internal forces only. External force is zero.

A. If both Assertion and Reason are correct and Reason is the correct explanation of Assertion.

B. If both Assertion and Reason are correct but Reason is not the correct explanation of Assertion.

C. If Assertion is true but Reason is false.

D. If Assertion is false but Reason is true.

**Answer: A**

 [Watch Video Solution](#)

**10.** Assertion: The centre mass of an electron and proton, when released moves faster towards proton.

Reason: Proton is heavier than electron.

- A. If both Assertion and Reason are correct and Reason is the correct explanation of Assertion.
- B. If both Assertion and Reason are correct but Reason is not the correct explanation of Assertion.
- C. If Assertion is true but Reason is false.
- D. If Assertion is false but Reason is true.

**Answer: D**





[Watch Video Solution](#)

**11. Assertion:** The relative velocity of the two particles in head-on elastic collision is unchanged both in magnitude and direction.

**Reason:** The relative velocity is unchanged in magnitude but gets reversed in direction.

- A. If both Assertion and Reason are correct and Reason is the correct explanation of Assertion.
- B. If both Assertion and Reason are correct but Reason is not the correct explanation of Assertion.
- C. If Assertion is true but Reason is false.
- D. If Assertion is false but Reason is true.

**Answer: D**



[Watch Video Solution](#)

**12. Assertion:** If net force on a system is zero, then momentum of every individual body remains constant.

**Reason:** If momentum of a system is constant, then kinetic energy of the system may change.

- A. If both Assertion and Reason are correct and Reason is the correct explanation of Assertion.
- B. If both Assertion and Reason are correct but Reason is not the correct explanation of Assertion.
- C. If Assertion is true but Reason is false.
- D. If Assertion is false but Reason is true.

**Answer: D**



**Watch Video Solution**

**13.** Assertion: If a projectile explodes in mid air, then no external force acts on the projectile during explosions.

Reason: Center of mass in this case follows the same path.

- A. If both Assertion and Reason are correct and Reason is the correct explanation of Assertion.
- B. If both Assertion and Reason are correct but Reason is not the correct explanation of Assertion.
- C. If Assertion is true but Reason is false.
- D. If Assertion is false but Reason is true.

**Answer: D**



[Watch Video Solution](#)

**14.** Assertion: Two bodies moving in opposite directions with same magnitude of linear momentum collide each other. Then, after collision

both the bodies will come to rest.

Reason: Linear momentum of the system of bodies is zero.

- A. If both Assertion and Reason are correct and Reason is the correct explanation of Assertion.
- B. If both Assertion and Reason are correct but Reason is not the correct explanation of Assertion.
- C. If Assertion is true but Reason is false.
- D. If Assertion is false but Reason is true.

**Answer: D**

 [Watch Video Solution](#)

**15.** Assertion: A body is thrown with a velocity  $u$  inclined to the horizontal at some angle. It moves along a parabolic path and falls to the ground, Linear momentum of the body, during its motion, will remain conserved.

Reason: Throughout the motion of the body, a constant force acts on it.

- A. If both Assertion and Reason are correct and Reason is the correct explanation of Assertion.
- B. If both Assertion and Reason are correct but Reason is not the correct explanation of Assertion.
- C. If Assertion is true but Reason is false.
- D. If Assertion is false but Reason is true.

**Answer: D**



**Watch Video Solution**

**16.** Assertion : A moving ball having an inelastic collision with another moving ball can have larger kinetic energy after collision.

Reason: During a collision between two bodies, transfer of energy may take place from one body to another.

- A. If both Assertion and Reason are correct and Reason is the correct explanation of Assertion.

B. If both Assertion and Reason are correct but Reason is not the correct explanation of Assertion.

C. If Assertion is true but Reason is false.

D. If Assertion is false but Reason is true.

**Answer: D**

 [Watch Video Solution](#)

**17. Assertion:** A rocket launched vertically upward explodes at the highest point it reaches. the explosions produces three fragments with non-zero initial velocity. Then, the initial velocity vectors of all the three fragments are in one plane.

**Reason** For sum of momentum of three particles, all the three momentum vectors must be coplanar.

A. If both Assertion and Reason are correct and Reason is the correct explanation of Assertion.

B. If both Assertion and Reason are correct but Reason is not the correct explanation of Assertion.

C. If Assertion is true but Reason is false.

D. If Assertion is false but Reason is true.

**Answer: A**

 [Watch Video Solution](#)

**18.** Assertion: Two blocks A and B are connected at the two ends of an ideal spring as shown in figure. Initially, spring was released. Now block B is pressed. Linear momentum of the system will not remain constant till the spring reaches its initial natural length.

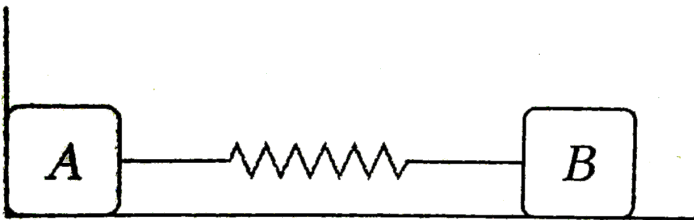

Reason: An external force will act from the wall on block A.

- A. If both Assertion and Reason are correct and Reason is the correct explanation of Assertion.
- B. If both Assertion and Reason are correct but Reason is not the correct explanation of Assertion.
- C. If Assertion is true but Reason is false.
- D. If Assertion is false but Reason is true.

**Answer: A**



**Watch Video Solution**

**19. Assertion:** In the figure shown, linear momentum of system (of blocks A and B) moves towards right during motion of block A over the block B.



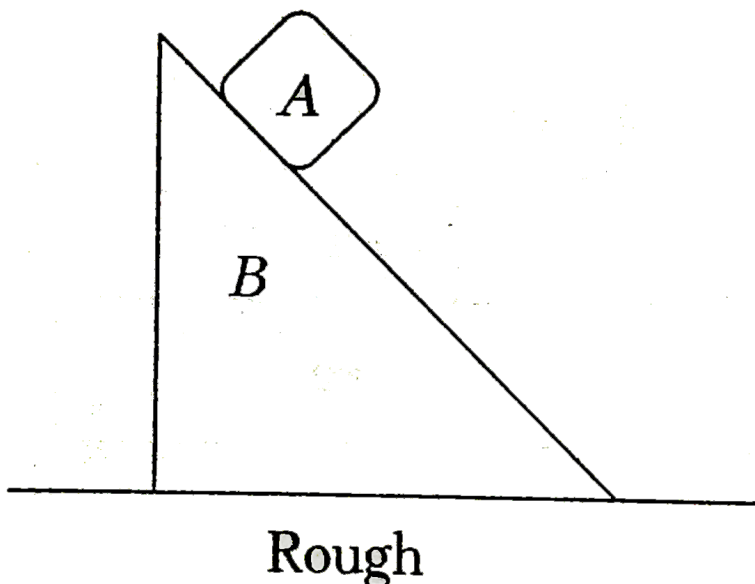

Reason: Initial acceleration of center of mass is towards right.

- A. If both Assertion and Reason are correct and Reason is the correct explanation of Assertion.
- B. If both Assertion and Reason are correct but Reason is not the correct explanation of Assertion.
- C. If Assertion is true but Reason is false.
- D. If Assertion is false but Reason is true.

**Answer: A**

 [Watch Video Solution](#)

20. Assertion: Two blocks of masses  $m_A$  and  $m_B$  ( $> m_A$ ) are thrown towards each other with same speed over a rough ground. The coefficient of friction of both the blocks with ground is same. Initial velocity of CM is towards left.

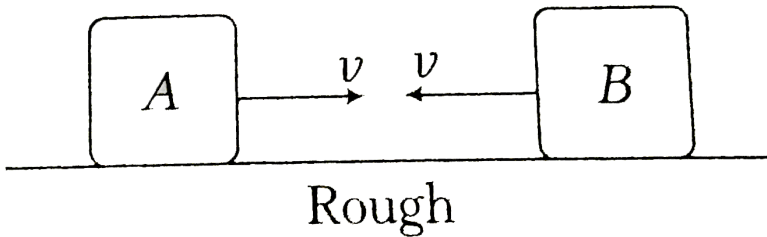

Reason: Initial acceleration of center of mass is towards right.

- A. If both Assertion and Reason are correct and Reason is the correct explanation of Assertion.
- B. If both Assertion and Reason are correct but Reason is not the correct explanation of Assertion.
- C. If Assertion is true but Reason is false.
- D. If Assertion is false but Reason is true.

Answer: B

 Watch Video Solution

21. Assertion: Two identical spherical spheres are half filled with two liquids of densities  $\rho_1$  and  $\rho_2 (> \rho_1)$ . The center of mass of both the spheres lie at same level.

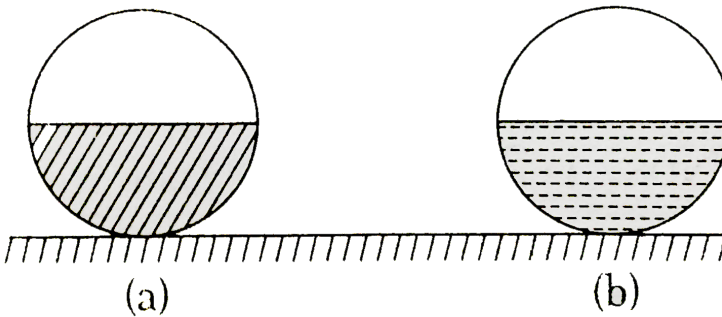

Reason: The center of mass will lie at center of the sphere.

- A. If both Assertion and Reason are correct and Reason is the correct explanation of Assertion.
- B. If both Assertion and Reason are correct but Reason is not the correct explanation of Assertion.

C. If Assertion is true but Reason is false.

D. If Assertion is false but Reason is true.

**Answer: C**



**Watch Video Solution**

## Match the columns

1. If net force on a system of particles is zero. Then

Column I

- (A) Acceleration of centre of mass
- (B) Velocity of centre of mass
- (C) Momentum of centre of mass
- (D) Velocity of an individual particle of the system

Column II

- (p) Constant
- (q) Zero
- (r) May be zero
- (s) May be constant



**Watch Video Solution**

2. Four point masses are placed at four corners of a square of side 4m as shown. Match the following columns.

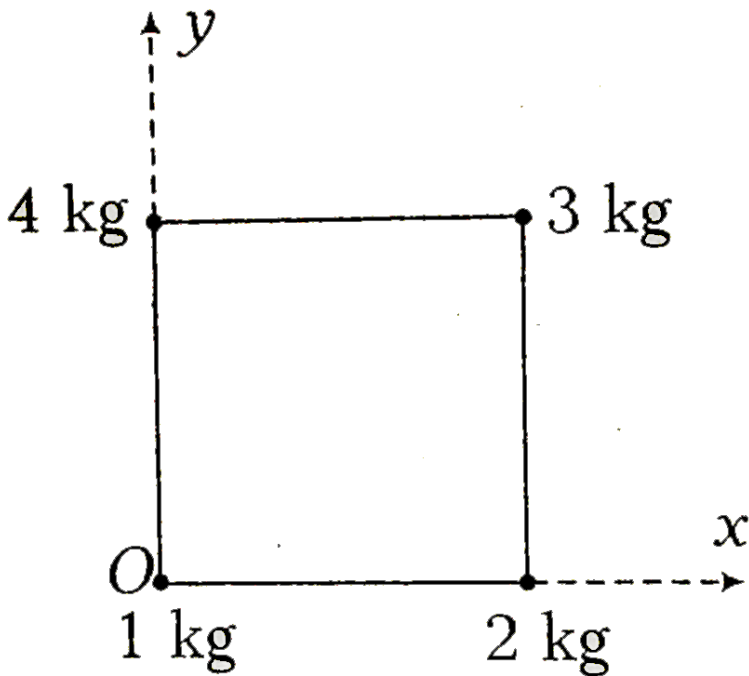

Column1

A x-coordinate of center of mass of 4kg and 2kg

B x-coordinates of center of mass of 4kg 2kg and 3kg

C y-coordinate of center of mass of 1kg 4kg and 3kg

y-coordinate of center of mass of 1kg and 3kg

Column2

P  $(7/2)m$

Q  $(4/3)m$

R  $3m$

$(20/9)m$



[Watch Video Solution](#)

3. In the diagram shown in figure mass of both the balls in same. Match the following columns.

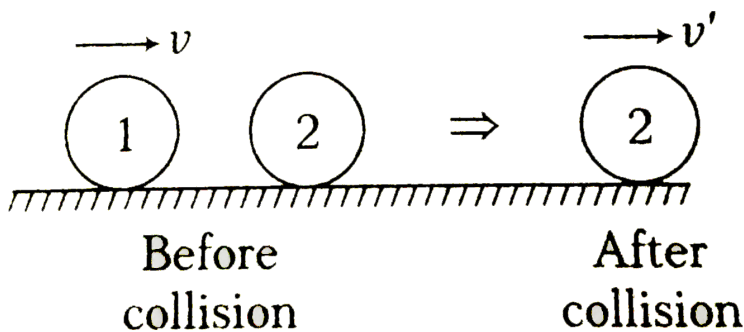

Column1

Column2

A For  $v' = v$

P  $e=0$

B For  $v' = v/2$

Q  $e=1$

C For  $v' = 3/4v$

R  $e=1/2$

- (S data is insufficient)

[▶ Watch Video Solution](#)

4. A particle of mass  $1\text{kg}$  has velocity  $\vec{v}_1 = (2t)\hat{i}$  and another particle of mass  $2\text{kg}$  has velocity  $\vec{v}_2 = (t^2)\hat{j}$

Column I

Column II

(A) Net force on centre of mass at 2 s

(p)  $\frac{20}{9}\text{unit}$

(B) Velocity of centre of mass at 2 s

(q)  $\sqrt{68}\text{ unit}$

(C) Displacement of centre of mass in 2s

(r)  $\frac{\sqrt{80}}{3}\text{unit}$

(s) None

[▶ Watch Video Solution](#)

5. In the arrangement shown in figure match the following

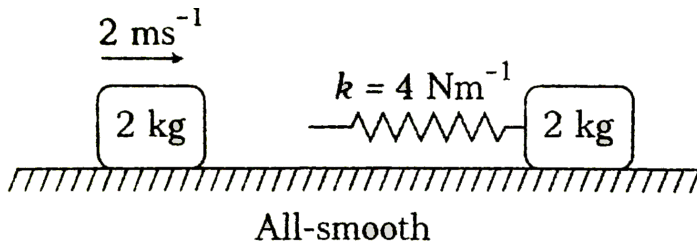

column1

- A Velocities of center of mass
- B Velocity of combined mass when compression in the spring is maximum
- C Maximum compression in the spring
- D Maximum potential energy stored in the spring

[View Text Solution](#)

6. A particle of mass  $m$ , kinetic energy  $K$  and momentum  $p$  collides head on elastically with another particle of mass  $2m$  at rest. After collision, :

Column I

Column II

- |                                       |                    |
|---------------------------------------|--------------------|
| (A) Momentum of first particle        | (p) $3/4p$         |
| (B) Momentum of second particle       | (q) $-K/9$         |
| (C) Kinetic energy of first particle  | (r) $-p/3$         |
| (D) Kinetic energy of second particle | (s) $\frac{8K}{9}$ |
|                                       | (t) None           |

[Watch Video Solution](#)

7. A particle of mass 1 kg is projected upwards with velocity  $60ms^{-1}$ . Another particle of mass 2kg is just dropped from a certain height. After 2s, match the following.

[Take,  $g = 10ms^{-2}$ ]

column1	column2
Acceleration of CM	P Zero
B Velocity of CM	Q 10 SI unit
C Displacement of CM	20 SI unit
-	S None



[View Text Solution](#)

8. Match the following: (P = momentum of particle, K = kinetic energy of particle)



Column-1	Column-2
(A) $P$ is increased by 200%, corresponding change in $K$	(P) 800%
(B) $K$ is increased by 300%, corresponding change in $P$	(Q) 200%
(C) $P$ is increased by 1%, corresponding change in $K$	(R) 0.5%
(D) $K$ is increased by 1%, corresponding change in $P$	(S) 2%
	(T) None

[▶ Watch Video Solution](#)

9. In a two block system in figure match the following.

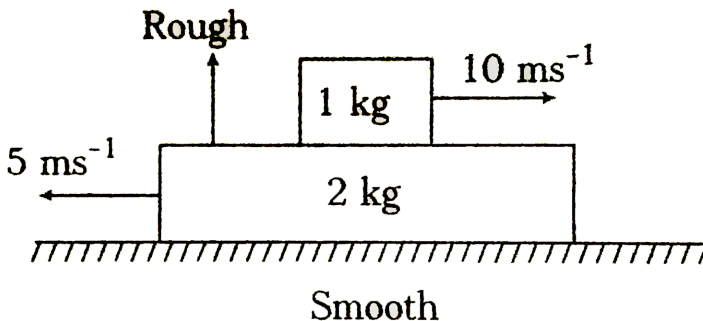

Column1

- A Velocity of center of mass
- B Momentum of center of mass
- C Momentum of 1kg block
- D Kinetic energy of 2kg block

Column2

- P Keep on changing all the time
- Q First decreases then become zero
- R Zero
- S Constant



[View Text Solution](#)

## Medical entrances gallery

1. A rod of weight  $w$  is supported by two parallel knife edges A and B and is in equilibrium in a horizontal position. The knives are at a distance  $d$  from each other. The centre of mass of the rod is at distance  $x$  from A. The normal reaction on A is.. And on B is.....

A.  $\frac{wx}{d}$

B.  $\frac{wd}{x}$

C.  $\frac{w(d-x)}{x}$

D.  $\frac{w(d-x)}{d}$

**Answer: D**



[Watch Video Solution](#)

2. Two particles of masses  $m_1, m_2$  move with initial velocities  $u_1$  and  $u_2$ . On collision, one of the particles get excited to higher level, after absorbing energy. If final velocities of particles be  $v_1$  and  $v_2$  then we must have

A.  $m_1^2 u_1 + m_2^2 u_2 - \varepsilon = -m_1^2 v_1 + m_2^2 v_2$

B.  $\frac{1}{2} m_1 u_1^2 + \frac{1}{2} m_2 u_2^2 = \frac{1}{2} m_1 v_1^2 + \frac{1}{2} m_2 v_2^2 - \varepsilon$

C.  $\frac{1}{2} m_1 u_1^2 + \frac{1}{2} m_2 u_2^2 - \varepsilon = \frac{1}{2} m_1 v_1^2 + \frac{1}{2} m_2 v_2^2$

D.  $\frac{1}{2} m_1^2 u_1^2 + \frac{1}{2} m_2^2 u_2^2 + \varepsilon = \frac{1}{2} m_1^2 v_1^2 + \frac{1}{2} m_2^2 v_2^2$

**Answer: C**



**Watch Video Solution**

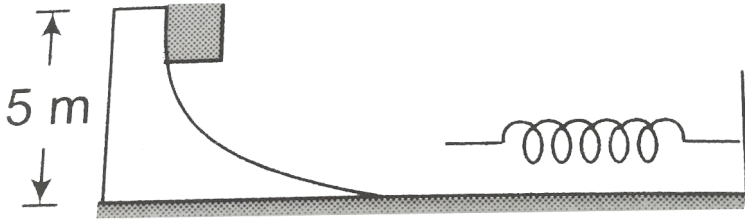

3.

The figure shows a smooth curved track terminating in a smooth horizontal part. A spring of spring constant  $400(N)/(m)$  is attached at one end to a wedge fixed rigidly with the horizontal part. A 40 g mass is released from rest at a height of 5 m on the curved track. The maximum compression of the spring will be

- A. 9.8 m
- B. 9.8cm
- C. 0.98 m
- D. 0.009 km

**Answer: B**



**Watch Video Solution**

4. A block having mass  $m$  collides with another stationary block having mass  $2m$ . The lighter block comes to rest after collision. If the velocity of first block is  $v$ , then the value of coefficient of restitution will be

A. 0.5

B. 0.4

C. 0.6

D. 0.8

**Answer: A**



[Watch Video Solution](#)

5. A smooth curved surface of height 10 m is ended horizontally. A spring of force constant  $200 \text{ Nm}^{-1}$  is fixed at the horizontal end as shown in figure when an object of mass 10g is released from the top, it travels along the curved path and collides with the spring. Then, the maximum compression in the spring is (Take,  $g = 10 \text{ ms}^{-2}$ )

A. 10m

B. 0.1 cm

C. 1 m

D. 0.01 m

**Answer: B**



**Watch Video Solution**

6. A frog sits on the end of a long board of length  $L = 5m$ . The board rests on a frictionless horizontal table. The frog wants to jump to the opposite end of the board. What is the minimum take-off speed (in  $m/s$ ), i.e., relative to ground ' $v$ ' that allows the frog to do the trick? The board and the frog have equal masses.

A.  $2\sqrt{5}ms^{-1}$

B.  $5ms^{-1}$

C.  $5\sqrt{2}ms^{-1}$

D.  $10\sqrt{2}ms^{-1}$

**Answer: C**



**Watch Video Solution**

7. A particle of mass  $m$ , collides with another stationary particle of mass  $M$ . If the particle  $m$  stops just after collision, then the coefficient of restitution for collision is equal to

A. 1

B.  $\frac{m}{M}$

C.  $\frac{M - m}{M + m}$

D.  $\frac{m}{M + m}$

**Answer: B**



**Watch Video Solution**

8. A body from height  $h$  is dropped, if the coefficient of restitution is  $e$ , then calculate the height achieved after one bounce.

A.  $h_1 = e^4 h$

B.  $h = e h_1$

C.  $h_1 = h e^2$

D.  $h = h_1 / e$

**Answer: C**



[Watch Video Solution](#)

9. Three particles of masses 0.50 kg, 1.0 kg and are placed at the corners of a right angle triangle, as shown in fig. Locate the centre of mass of the



system.

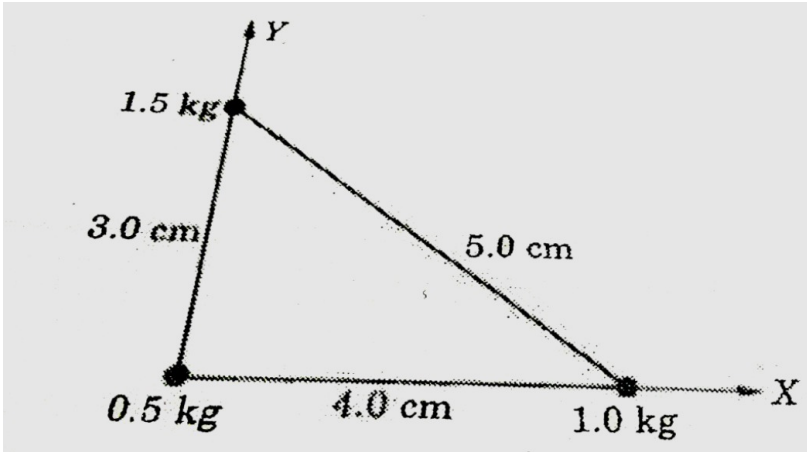

- A. (1.3, 1.5)
- B. (2.3, 1.5)
- C. (1.3, 2.5)
- D. (2.3, 2.5)

**Answer: A**

[Watch Video Solution](#)

10. A large number of particles are placed around the origin, each at a distance  $R$  from the origin. The distance of the center of mass of the

system from the origin is

- A. equal to  $R$
- B. less than or equal to  $R$
- C.
- D. greater than  $R$

**Answer: B**



[Watch Video Solution](#)

**11.** A circular disc rolls on a horizontal floor without slipping and the center of the disc moves with a uniform velocity  $v$ . Which of the following values of the velocity at a point on the rim of the disc can have?

- A.  $v$
- B.  $-v$
- C.  $3v$

D. Zero

**Answer: D**

 [Watch Video Solution](#)

12. The linear momentum of a particle varies with time  $t$  as  $p = a + bt + ct^2$ . Then, whichh of the following is correct?

- A. Velocity of particle is inversely proportional to time
- B. Displacement of the particle is independent of time
- C. Forces varies with time in a quadratic manner
- D. Force is independent linearly on time

**Answer: D**

 [Watch Video Solution](#)

13. A body of mass  $(4m)$  is laying in  $xy$ -plane at rest. It suddenly explodes into three pieces. Two pieces each mass  $(m)$  move perpendicular to each other with equal speeds  $(v)$ . Total kinetic energy generated due to explosion is

A.  $mv^2$

B.  $\left(\frac{3}{2}\right)mv^2$

C.  $2mv^2$

D.  $4mv^2$

**Answer: B**



[Watch Video Solution](#)

14. The position of center of mass of a system of particles does not depend upon the

A. mass of particles

B. symmetry of the body

C. position of the particles

D. nature of particles.



[Watch Video Solution](#)

15. A bullet is fired from the gun. The gun recoils, the kinetic energy of the recoil shall be-

A.  $K$

B. more than  $K$

C. less than  $K$

D.  $\sqrt{K}$

**Answer: C**



[Watch Video Solution](#)

16. An explosion blows a rock into three parts. Two parts go off at right angles to each other . These two are  $1\text{kg}$  first part moving with a velocity of  $12\text{ms}^{-1}$  and  $2\text{kg}$  second part moving with a velocity of  $8\text{ms}^{-1}$ . If the third part flies off with a velocity of  $4\text{ms}^{-1}$ . Its mass would be

- A. 3 kg
- B. 5 kg
- C. 7 kg
- D. 17 kg

**Answer: B**



**Watch Video Solution**

17. The linear momentum is conserved in

- A. elastic collisions
- B. inelastic collisions

C. Both a and B

D. Neither a nor b

**Answer: C**

 [Watch Video Solution](#)

18. Three particles, each of mass  $m$ , are placed at the vertices of a right angled triangle as shown in figure. The position vector of the center of mass of the system is ( $O$  is the origin and  $\hat{i}, \hat{j}, \hat{k}$  are unit vectors)

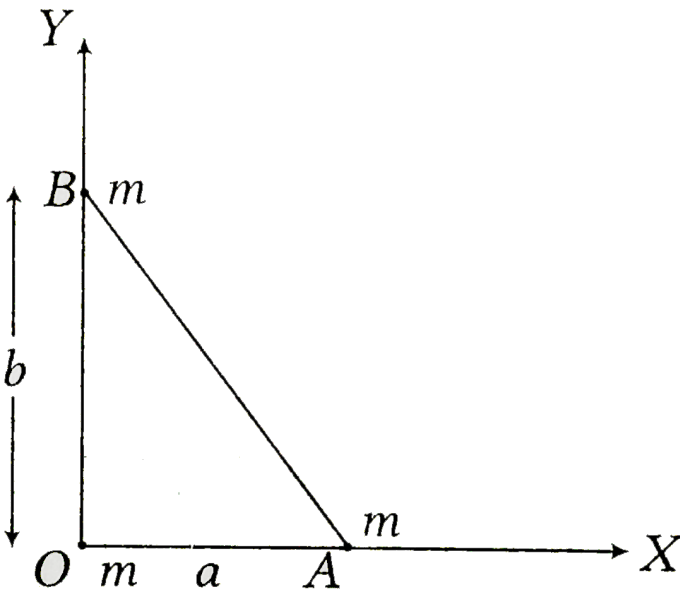

A.  $\frac{1}{3}(a\hat{i} - b\hat{j})$

B.  $\frac{2}{3}(a\hat{i} - b\hat{j})$

C.  $\frac{2}{3}(a\hat{i} + b\hat{j})$

D.  $\frac{1}{3}(a\hat{i} + b\hat{j})$

**Answer: D**



**Watch Video Solution**

**19.** A ball of mass 'm' moving with a horizontal velocity 'v' strikes the bob of mass 'm' of a pendulum at rest. During this collision, the ball sticks with the bob of the pendulum. The height to which the combined mass raises is (g = acceleration due to gravity).

A.  $\frac{v^2}{4g}$

B.  $\frac{v^2}{8g}$

C.  $\frac{v^2}{g}$

D.  $\frac{v^2}{2g}$



**Answer: B**



[Watch Video Solution](#)

**20.** In an inelastic collision

- A. momentum is not conserved
- B. momentum is conserved but kinetic energy is not conserved
- C. both momentum and kinetic energy are conserved.
- D. neither momentum nor kinetic energy is conserved

**Answer: B**



[Watch Video Solution](#)

**21.** A body of mass  $m_1$  moving with uniform velocity of 40 m/s collides with another mass  $m_2$  at rest and then the two together begin to move with uniform velocity of 30 m/s. the ratio of their masses  $\frac{m_1}{m_2}$  is

A. 1 : 3

B. 3 : 1

C. 1 : 1.33

D. 1 : 0.75

**Answer: B**

 [Watch Video Solution](#)

**22.** Two sphere  $A$  and  $B$  of masses  $m_1$  and  $m_2$  respectively colides.  $A$  is at rest initaly and  $B$  is moving with velocity  $v$  along  $x$ -axis. After collision  $B$  has a velocity  $\frac{v}{2}$  in a direction perpendicular to the original direction. The mass  $A$  moves after collision in the direction.

A. same as that of B

B. opposite to that of B

C.  $\theta = \tan^{-1} \left( \frac{1}{2} \right)$  to the X-axis

D.  $\theta = \tan^{-1} \left( -\frac{1}{2} \right)$  to the X-axis

**Answer: C**



[Watch Video Solution](#)

**23.** Two persons of masses  $55\text{kg}$  and  $65\text{kg}$  respectively are at the opposite ends of a boat. The length of the boat is  $3.0\text{m}$  and weights  $100\text{kg}$ . The  $55\text{kg}$  man walks up to the  $65\text{kg}$  man and sits with him. If the boat is in still water the centre of mass of the system shifts by.

A.  $3.0\text{ m}$

B.  $2.3\text{ m}$

C. zero

D.  $0.75\text{ m}$

**Answer: C**



[Watch Video Solution](#)

24. A ball moving with a speed of  $9m/s$  strikes an identical ball at rest, such that after the collision, the direction of each ball makes an angle of  $30^\circ$  with the original line of motion. Find the speeds of the two balls after collision.

A.  $5.2ms^{-1}$

B.  $0.52ms^{-1}$

C.  $52ms^{-1}$

D.  $26ms^{-1}$

**Answer: A**



**Watch Video Solution**

25. A body of mass  $0.25\text{ kg}$  is projected with muzzle velocity  $100ms^{-1}$  from a tank of mass  $100\text{ kg}$ . What is the recoil velocity of the tank

A.  $5ms^{-1}$

B.  $25ms^{-1}$

C.  $0.5ms^{-1}$

D.  $0.25ms^{-1}$

**Answer: D**



**Watch Video Solution**

26. A body of mass  $m_1 = 4\text{kg}$  moves at  $5\hat{i}\text{ms}^{-1}$  and another body of mass  $m_2 = 2\text{kg}$  moves at  $10\hat{i}\text{ms}^{-1}$ . The kinetic energy of center of mass is

A.  $\frac{200}{3}\text{J}$

B.  $\frac{500}{3}\text{J}$

C.  $\frac{400}{3}\text{J}$

D.  $\frac{800}{3}\text{J}$

**Answer: C**

[Watch Video Solution](#)

27. A mass of 10 gm moving with a velocity of 100 cm / s strikes a pendulum bob of mass 10 gm . The two masses stick together. The maximum height reached by the system now is ( $g = 10m/s^2$ )

A. Zero

B. 1.25 cm

C. 2.5 cm

D. 5cm

**Answer: B**

[Watch Video Solution](#)

Only one option is correct for JEE Mains

1. Two particles having mass ratio  $n:1$  are interconnected by a light inextensible string that passes over a smooth pulley . If the system is released , then the acceleration of the centre of mass of the system is

A.  $(n - 1)^2 g$

B.  $\left(\frac{n + 1}{n - 1}\right)^2 g$

C.  $\left(\frac{n - 1}{n + 1}\right)^2 g$

D.  $\left(\frac{n + 1}{n - 1}\right)g$



[Watch Video Solution](#)

2. A ball of mass 50 gm is dropped from a height  $h=10m$ . It rebounds losing 75 percent of its kinetic energy. If it remains in contact with the ground for  $\Delta t = 0.01$  sec. the impulse of the impact force is (take  $g = 10m/s^2$ )

A.  $1.3N - s$

B. 1.06 N-s

C. 1300 N-s

D. 105 N-s



[Watch Video Solution](#)

3. In an arrangement shown, bob A on the left is pulled aside. It is then released and allowed to collide with other bob B which is at rest. A perfectly inelastic collision occurs and the system rises to a height  $h/4$ .



The ratio of the masses of the bobs is

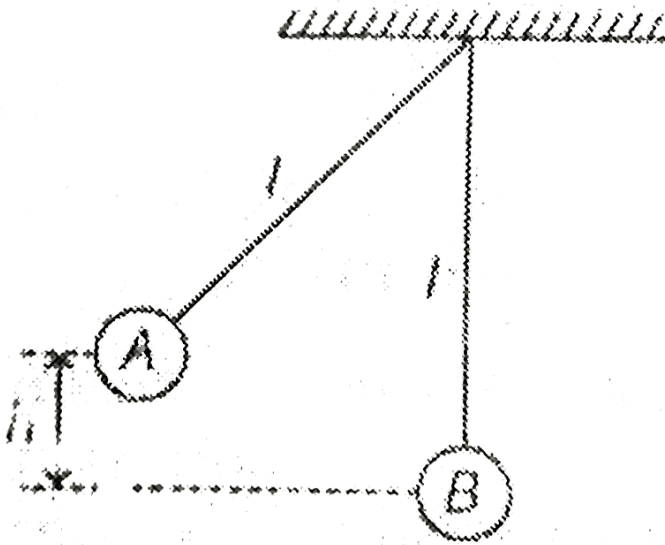

- A. 1
- B. 2
- C. 3
- D. 4

[▶ Watch Video Solution](#)

4. There are hundred identical blocks equally spaced on a frictionless track as shown in the figure . Initially , all the blocks are separate . Each collision is perfectly inelastic . The final velocity will be

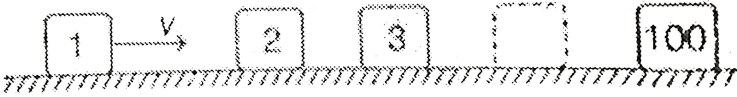

A.  $\frac{V}{99}$

B.  $\frac{V}{100}$

C. zero

D. NONE



[Watch Video Solution](#)

5. A stationary body explodes into two fragments of masses  $m_1$  and  $m_2$ . If momentum of one fragment is  $p$ , the energy of explosion is

A.  $\frac{p^2}{2(m_1 + m_2)}$

B.  $\frac{p^2}{2\sqrt{m_1 + m_2}}$

C.  $\frac{p^2(m_1 + m_2)}{2m_1m_2}$

D.  $\frac{p^2(m_1 + m_2)}{m_1m_2}$



[Watch Video Solution](#)

6. A ball collides with an inclined plane of inclination  $\theta$  after falling through a distance  $h$ . if it moves horizontal just after the impact, the coefficient of restitution is

A.  $\tan^2 \theta$

B.  $\cot^2 \theta$

C.  $\tan \theta$

D.  $\cot \theta$



[Watch Video Solution](#)

7. Three blocks are initially placed as shown in the figure. Block  $A$  has mass  $m$  and initial velocity  $v$  to the right. Block  $B$  with mass  $m$  and block  $C$  with mass  $4m$  are both initially at rest. Neglect friction. All collisions are elastic. The final velocity of blocks  $A$  is

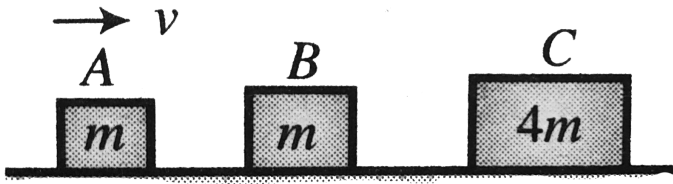

- A.  $0.6 v$  to the left
- B.  $0.4 v$  to the left
- C.  $v$  to the left
- D.  $0.4 v$  to the right



[Watch Video Solution](#)

8. A force exerts an impulse  $I$  on a particle changing its speed from initial velocity  $u$  to final velocity  $2u$ . The applied force and the initial velocity are oppositely oriented along the same line. The work done by the force is

A.  $\frac{3}{2} I u$

B.  $\frac{1}{2} I u$

C.  $I u$

D.  $2 I u$



Watch Video Solution

9. A ball is projected from ground with a velocity  $V$  at an angle  $\theta$  to the vertical. On its path it makes an elastic collision with a vertical wall and returns to ground. The total time of flight of the ball is

A.  $\frac{2v\sin\theta}{g}$

B.  $\frac{2v\cos\theta}{g}$

C.  $\frac{v \sin 2\theta}{g}$

D.  $\frac{v \cos \theta}{g}$

 [Watch Video Solution](#)

10. An open water tight railway wagon of mass  $5 \times 10^3 \text{ kg}$  moves at an initial velocity  $1.2 \text{ m/s}$  without friction on a railway track. Rain drops fall vertically downwards into the wagon. The velocity of the wagon after it has collected  $10^3 \text{ kg}$  of water will be :-

A. 0.5 m/s

B. 0.6 m/s

C. 1 m/s

D. 0.8 m/s

 [Watch Video Solution](#)

11. A rocket of mass 4000 kg is set for vertical firing. How much gas must be ejected per second so that the rocket may have initial upwards acceleration of magnitude  $19.6m/s^2$  ? [Exhaust speed of fuel =  $980m/s$  ]

A.  $240kgs^{-1}$

B.  $60kgs^{-1}$

C.  $120kgs^{-1}$

D.  $20kgs^{-1}$



Watch Video Solution

12. A 2kg toy car can move along an x axis. Graph shows force  $F_x$  , acting on the car which being at rest at time  $t = 0$  . The velocity of the particle

at  $t = 0\text{ s}$  is:

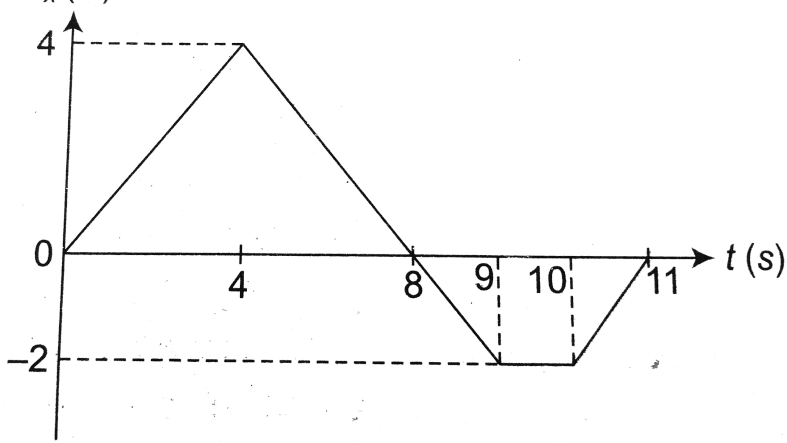

- A. 2 m/s
- B. 5 m/s
- C. 6.5 m/s
- D. 4.5 m/s



[Watch Video Solution](#)

13. The displacement of a particle of mass 2kg moving in a straight line varies with times as  $x = (2t^3 + 2)\text{ m}$ . Impulse of the force acting on the



particle over a time interval between  $t = 0$  and  $t = 1$  s is

A. 10 N-s

B. 12 N-s

C. 8 N-s

D. 6 N-s



[Watch Video Solution](#)

**14.** Ball 1 collides directly with another identical ball 2 at rest. Velocity of second ball becomes two times that of 1 after collision. Find the coefficient of restitution between the two balls?



[Watch Video Solution](#)

**15.** A particle of mass 1 kg is projected at an angle of  $30^\circ$  with horizontal with velocity  $v = 40$  m/s . The change in linear momentum of the particle

after time  $t = 1$  s will be ( $g = 10 \text{ m/s}^2$ )

A.  $7.5 \text{ kg} \cdot \text{m/s}$

B.  $15 \text{ kg} \cdot \text{m/s}$

C.  $10 \text{ kg} \cdot \text{m/s}$

D.  $20 \text{ kg} \cdot \text{m/s}$



[Watch Video Solution](#)

**16.** Two blocks of masses  $3\text{kg}$  and  $6\text{kg}$  respectively are placed on a smooth horizontal surface. They are connected by a light spring of force constant  $k = 200\text{N/m}$ . Initially the spring is unstretched. The indicated velocities

are imparted to the blocks. Find the maximum extension of the spring.

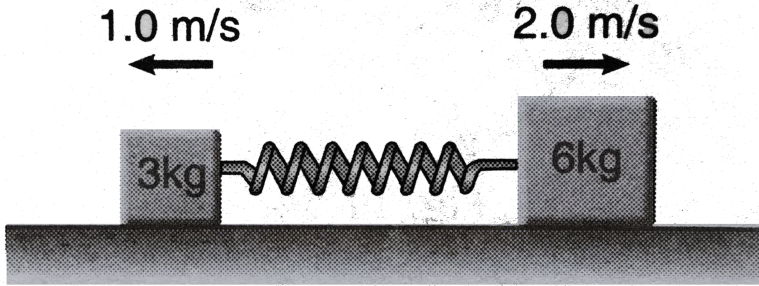

- A. 30 cm
- B. 25 cm
- C. 20 cm
- D. 15 cm



[Watch Video Solution](#)

17. The centre of mass of a non uniform rod of length  $L$ , whose mass per unit length varies as  $\rho = \frac{k \cdot x^2}{L}$  where  $k$  is a constant and  $x$  is the distance of any point from one end is (from the same end)

A.  $\frac{3L}{4}$

B.  $\frac{L}{8}$

C.  $\frac{K}{L}$

D.  $\frac{3K}{L}$



Watch Video Solution

18. A particle of mass  $m$  is made to move with uniform speed  $u$  along the perimeter of a regular polygon of  $n$  sides. What is the magnitude of impulse applied by the particle at each corner of the polygon?

A.  $2 mv \sin \frac{\pi}{2n}$

B.  $mv \sin \frac{\pi}{2n}$

C.  $m v \cos \frac{\pi}{2n}$

D.  $2 mv \cos \frac{\pi}{2n}$

[Watch Video Solution](#)

19. From a circular disc of radius  $R$ , a square is cut out with a radius as its diagonal. The center of mass of remaining portion is at a distance from the center)

A.  $\frac{R}{\pi - 2}$

B.  $\frac{R}{\pi}$

C.  $\frac{R}{2(2\pi - 1)}$

D.  $\frac{R}{2}$

[Watch Video Solution](#)

20. A Force  $F = (2\hat{i} + \hat{j} + 3\hat{k})$  N acts on a particle of mass 1 kg for 2 s . If initial velocity of particle is  $u = (2\hat{i} + \hat{j})$  m/s . Speed of particle at the end of 2 s will be

A. 12 m/s

B. 6 m/s

C. 9 m/s

D. 4 m/s



Watch Video Solution

21. A bullet is fired from a gun. The force on a bullet is  $F = 600 - 2 \times 10^5 t$  newton. The force reduces to zero just when the bullet leaves barrel. Find the impulse imparted to the bullet.

A. 8 N-s

B. 0.9 N-s

C. 1.8 N-s

D. 2.4 N-s



Watch Video Solution

22. A uniform rod of length  $l$  is kept vertically on a rough horizontal surface at  $x = 0$ . It is rotated slightly and released. When the rod finally falls on the horizontal surface, the lower end will remain at

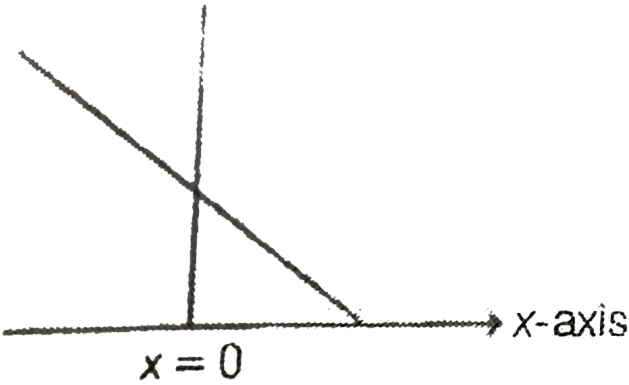

- A.  $x = l/2$
- B.  $x > l/2$
- C.  $x < l/2$
- D.  $x = 0$



Watch Video Solution

23. An object comprises of a uniform ring of radius  $R$  and its uniform chord  $AB$  (not necessarily made of the same material) as shown. Which of the following can not be the centre of mass of object

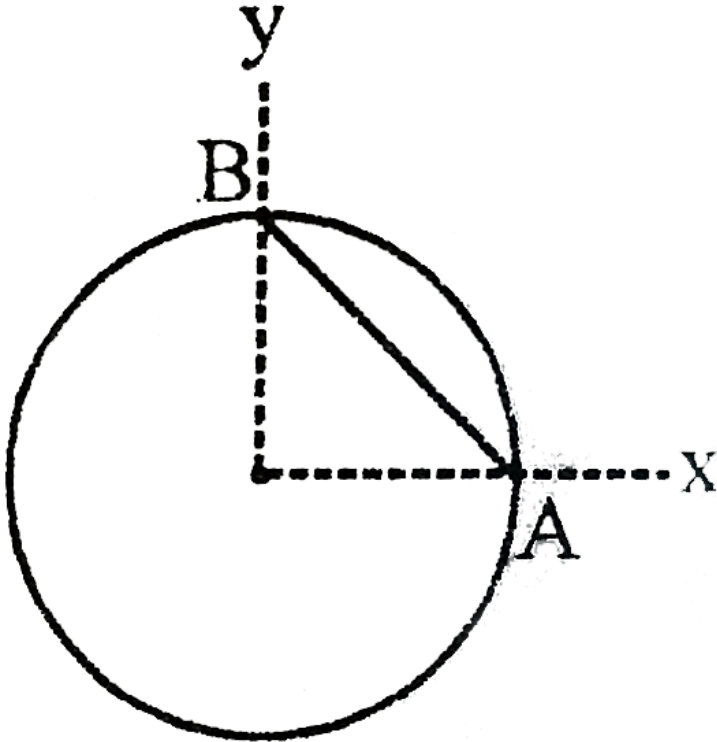

A.  $(R/3, R/3)$

B.  $(R/\sqrt{2}, R/\sqrt{2})$

C.  $(R/4, R/4)$



D. None of these



[Watch Video Solution](#)

**24.** A projectile of mass  $3m$  explodes at highest point of its path. It breaks into three equal parts. One part retraces its path, the second one comes to rest. The range of the projectile was  $100\text{ m}$  if no explosion would have taken place. The distance of the third part from the point of projection when it finally lands on the ground is -

A.  $100\text{ m}$

B.  $50\text{ m}$

C.  $250\text{ m}$

D.  $300\text{ m}$



[Watch Video Solution](#)

25. A metre rule, weighing 100 g rests on a table with a part projecting over the edge. Find the length of the part projecting out if a 5 g body hung at the end just tills the rule.

A. 37.5 cm

B. 26.8 cm

C. 40.2 cm

D. 47.6 cm



Watch Video Solution

26. Four particle of masses  $m_1 = 2m$ ,  $m_2 = 4m$ ,  $m_3 = m$  and  $m_4$  are placed at four corners of a square. What should be the value of  $m_4$  so that the centres of mass of all the four particle are exactly at the centre

of the square ?

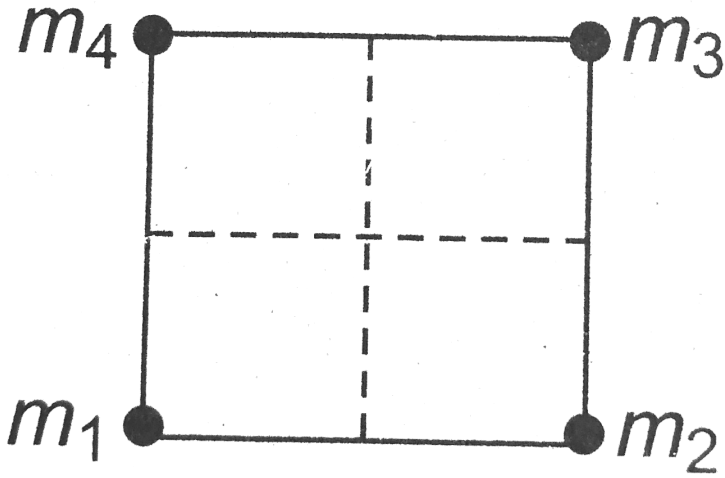

A.  $2m$

B.  $8m$

C.  $6m$

D. None of these



Watch Video Solution

27. Mass is non - uniformly distributed on the circumference of a ring of radius  $a$  and centre at origin . Let  $b$  be the distance of centre of mass of the ring from origin. Then ,

A.  $b = a$

B.  $0 \leq b \leq a$

C.  $b < a$

D.  $b > a$



Watch Video Solution

28. A man of mass 80 kg is riding on a small cart of mass 40 kg which is rolling along a level floor at a speed 2 m/s . He is running on the cart , so that his velocity relative to the cart is 3 m/s in the direction opposite to the motion of cart . What is the speed of the centre of the mass of the system ?

A. 1.5 m/s

B. 1 m/s

C. 3 m/s

D. Zero



Watch Video Solution

29. Two smooth objects with a coefficient of restitution  $e$ , collides directly and bounce as shown .

Newton ' law of restitution gives

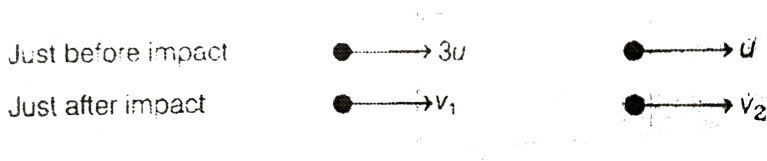

A.  $e \times 4u = v_2 + v_1$

B.  $e \times 2u = v_1 - v_2$

C.  $e \times 2u = v_2 - v_1$

D. It cannot be applied as the masses are not known



Watch Video Solution

**30.** Two billiard balls of same size and mass are in contact on a billiard table. A third ball of same mass and size strikes them symmetrically and remains at rest after the impact. Find the coefficient of restitution between the balls?

A.  $\frac{1}{2}$

B.  $\frac{1}{3}$

C.  $\frac{2}{3}$

D.  $\frac{3}{4}$



Watch Video Solution

31. After perfectly inelastic collision between two identical balls moving with same speed in different directions, the speed of the combined mass becomes half the initial speed. Find the angle between the two before collision.

A.  $60^\circ$

B.  $45^\circ$

C.  $120^\circ$

D.  $30^\circ$



Watch Video Solution

32. A ball strikes a horizontal floor at an angle  $\theta = 45^\circ$  with the normal to floor. The coefficient of restitution between the ball and the floor is  $e = 1/2$ . The fraction of its kinetic energy lost in the collision is.

A.  $\frac{5}{8}$

B.  $\frac{3}{8}$

C.  $\frac{3}{4}$

D.  $\frac{1}{4}$

 [Watch Video Solution](#)

**33.** A gardener waters the plants by a pipe of diameter 1 cm . The water comes out at the rate of 20 cc/s . The reactionary force exerted on the hand of the gardener is

A.  $2.54 \times 10^{-5}$  N

B.  $1.62 \times 10^{-3}$  N

C.  $5.1 \times 10^{-3}$  N

D. Zero

 [Watch Video Solution](#)



34. A bead can slide on a smooth straight wire and a particle of mass  $m$  attached to the bead by a light string of length  $L$ . The particle is held in contact with the wire and with the string taut and is then let fall. If the bead has mass  $2m$  then when the string makes an angle  $\theta$  with the wire, the bead will have slipped a distance.

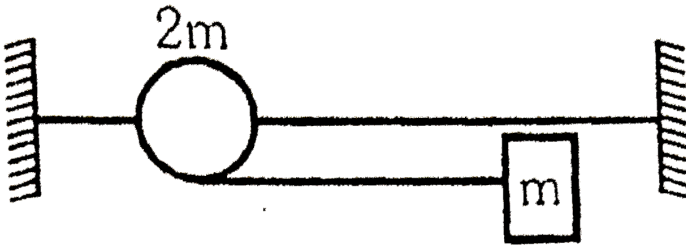

- A.  $L(1 - \cos\theta)$
- B.  $\frac{L}{2}(1 - \cos\theta)$
- C.  $\frac{L}{3}(1 - \cos\theta)$
- D.  $\frac{L}{6}(1 - \cos\theta)$



Watch Video Solution

35. A man of mass  $m$  moves with a constant speed on a plank of mass  $M$  and length  $l$  kept initially at rest on a frictionless horizontal surface, from one end to the other in time  $t$ . The speed of the plank relative to ground while man is moving, is

A.  $\frac{L}{t} \left( \frac{M}{m} \right)$

B.  $\frac{L}{t} \left( \frac{m}{M + m} \right)$

C.  $\frac{L}{t} \left( \frac{M}{M - m} \right)$

D. None of these



Watch Video Solution

36. Two particles of equal mass ' $m$ ' are projected from the ground with speed  $v_1$  and  $v_2$  at angles  $\theta_1$  and  $\theta_2$  at the same times as shown in figure.

The centre of mass of the two particles.

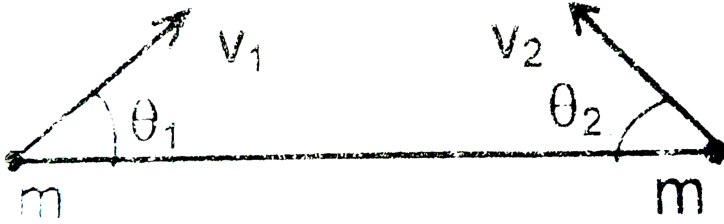

- A. will move in a parabolic path for any values of  $v_1$ ,  $v_2$ ,  $\theta_1$  and  $\theta_2$
- B. can move in a vertical line
- C. can move in horizontal line
- D. will move in a straight line for any value of  $v_1$ ,  $v_2$ ,  $\theta_1$  and  $\theta_2$



[Watch Video Solution](#)

**37.** Two blocks of masses 2 kg and 1 kg respectively are tied to the ends of a string which passes over a light frictionless pulley . The masses are held at rest at the same horizontal level and then released . The distance

traversed by centre of mass in 2 s ( $g = 10 \text{ m/s}^2$ )

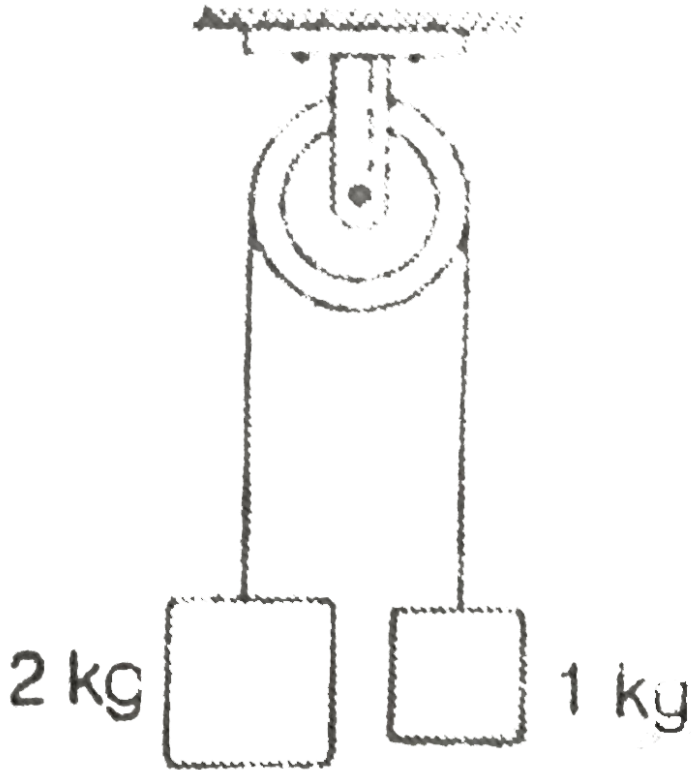

A. 1.42 m

B. 2.22 m

C. 3.12 m

D. 3.33 m

 [Watch Video Solution](#)

**38.** A boy of mass  $60kg$  is standing over a platform of mass  $40kg$  placed over a smooth horizontal surface. He throws a stone of mass  $1kg$  with velocity  $v = 10m/s$  at an angle of  $45^\circ$  with respect to the ground. Find the displacement of the platform (with boy) on the horizontal surface when the stone lands on the ground. Take  $g = 10m/s^2$ .

A. 25 cm

B. 5 cm

C. 10 cm

D. 50 cm

 [Watch Video Solution](#)

**39.** A particle of mass  $m$  moving with a speed  $v$  hits elastically another stationary particle of mass  $2m$  on a smooth horizontal circular tube of

radius  $r$ . Find the time when the next collision will take place?

A.  $\frac{2\pi r}{v}$

B.  $\frac{4\pi r}{v}$

C.  $\frac{3\pi r}{2v}$

D.  $\frac{\pi r}{v}$



Watch Video Solution

**40.** A particle of mass 100 g moving at an initial speed  $u$  collides with another particle of same mass kept initially at rest. If the total kinetic energy becomes 0.2 J after the collision what could be minimum and the maximum value of  $u$ .

A. minimum value of  $v$  is 2 m/s

B. maximum value of  $v$  is 4 m/s

C. minimum value of  $v$  is 3 m/s

D. maximum value of  $v$  is 6 m/s



Watch Video Solution

41. A sphere is moving with velocity vector  $2\hat{i} + 2\hat{j}$  immediately before it hits a vertical wall. The wall is parallel to  $\hat{j}$  and the coefficient of restitution of the sphere and the wall is  $e = \frac{1}{2}$ . Find the velocity of the sphere after it hits the wall?

A.  $\hat{i} - \hat{j}$

B.  $-\hat{i} + 2\hat{j}$

C.  $-\hat{i} - \hat{j}$

D.  $2\hat{i} - \hat{j}$



Watch Video Solution

**42.** In one dimensional elastic collision of equal masses, the velocities are interchanged. Can velocities in a one dimensional collision be interchanged if the masses are not equal?

- A. Only (i) is correct
- B. Only (ii) is correct
- C. Both (i) and (ii) are correct
- D. Both (i) and (ii) are wrong

 [Watch Video Solution](#)

**43.** Infinite number of bricks are placed one over the other as shown in the figure. Each succeeding brick having half the length and breadth of its preceding brick and the mass of each succeeding brick being  $(1/4)^{th}$  of the preceding one. Taking 'O' as the origin, the  $x$  coordinate of centre of



mass of the system of bricks is at

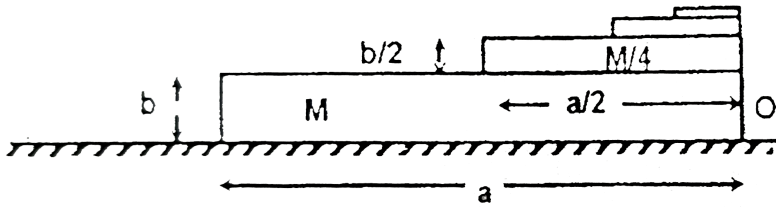

A.  $-\frac{a}{7}$

B.  $\frac{3a}{7}$

C.  $-\frac{3a}{7}$

D.  $-\frac{2a}{7}$



Watch Video Solution

44. A ball of mass  $m$  moving vertically down, collides with inclined surface of the wedge. After the collision, wedge starts moving in horizontal direction with velocity  $v_0$ . If all the surfaces are smooth then impulse

applied by wedge on the ball during collision is given by

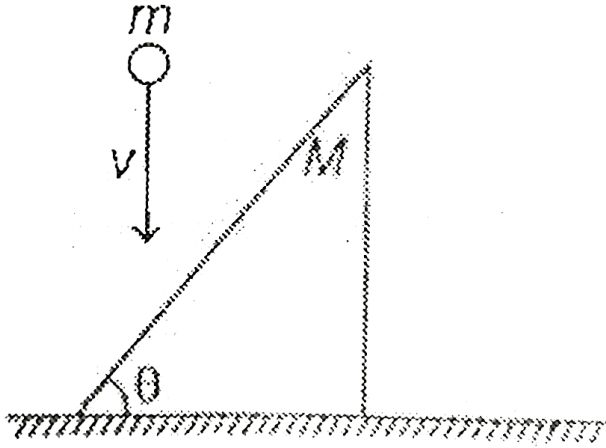

A.  $Mv_0 \sin \theta$

B.  $Mv_0 \cos \theta$

C.  $\frac{Mv_0}{\sin \theta}$

D.  $\frac{Mv_0}{\cos \theta}$



Watch Video Solution

**45.** Block  $A$  is hanging from a vertical spring and is at rest. Block  $B$  strikes the block  $A$  with velocity  $v$  and sticks to it. Then the value of  $v$  for which

the spring just attains natural length is

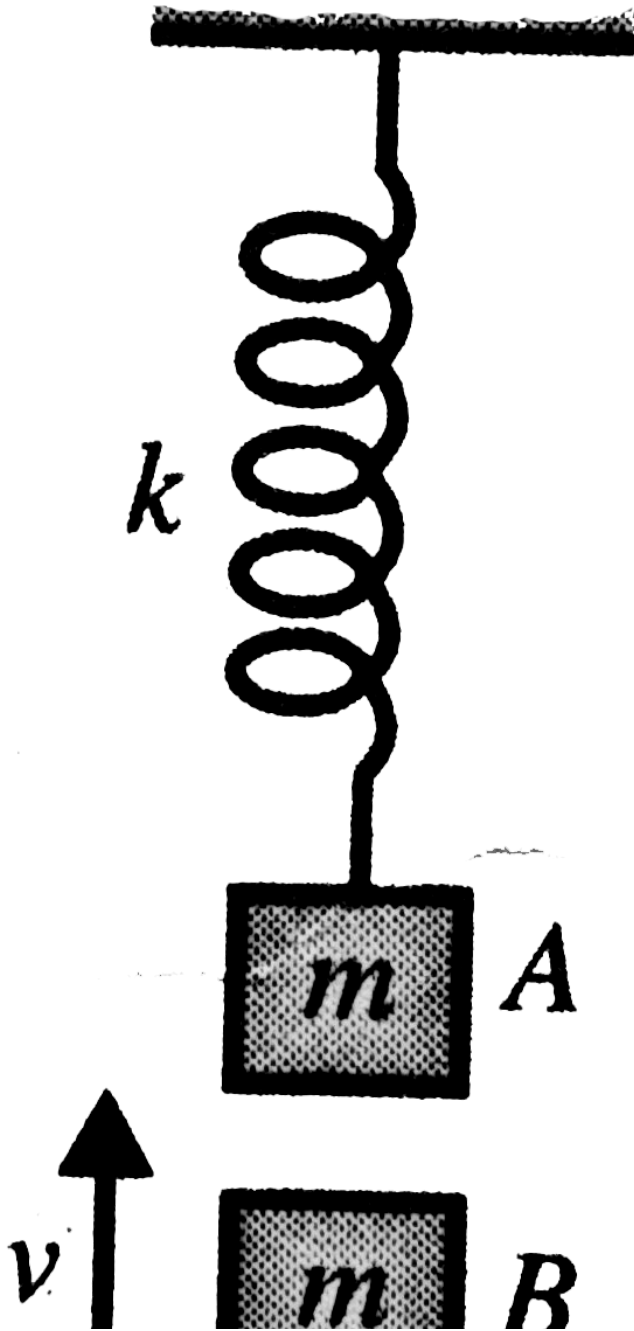

A.  $\sqrt{\frac{5mg^2}{k}}$

B.  $\sqrt{\frac{6mg^2}{k}}$

C.  $\sqrt{\frac{4mg^2}{k}}$

D.  $\sqrt{\frac{8mg^2}{k}}$

 [Watch Video Solution](#)

**46.** Three blocks of identical masses are placed on a frictionless table as shown . The centre block is at rest , whereas the other two blocks are moving directly towards the stationary block with identical speed  $v$  . The centre block is initially closer to the left block than the right one . All collisions are elastic . After long time , which of the following is true .



- A. The centre block is moving towards left
- B. The centre block is at rest somewhere to the left of its initial position .
- C. The centre block is at rest at its initial position
- D. The centre block is at rest somewhere to the right of its initial position .



[Watch Video Solution](#)

**47.** A stream of water droplets, each of mass  $m = 0.001\text{kg}$  are fired horizontally at a velocity of  $10\text{m/s}$  towards a vertical steel plate where they collide. The droplets are spaced equidistant with a spacing of  $1\text{cm}$ . What is approximate average force exerted on the plate by the water droplets. (Assuming that they do not rebound after collision.)

A. 10 N

B. 100 N

C. 1 N

D. 0.1 N



Watch Video Solution

Only one option is correct for JEE Advanced

1. As shown in the figure a body of mass  $m$  moving vertically with speed 3 m/s hits a smooth fixed inclined plane and rebounds with a velocity  $v_f$  in the horizontal direction . If angle of plane with horizontal is  $30^\circ$  , the

velocity  $v_f$  will be

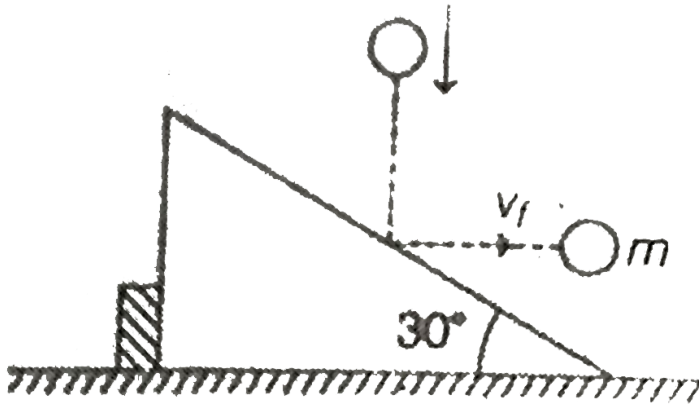

- A. 3 m/s
- B.  $\sqrt{3}$  m/s
- C.  $1/\sqrt{3}m/s$
- D. 2 m/s

[▶ Watch Video Solution](#)

2. A hemisphere of radius  $R$  and mass  $4m$  is free to slide with its base on a smooth horizontal table. A particle of mass  $m$  is placed on the top of

the hemisphere . The angular velocity of the particle relative to centre of hemisphere at an angular displacement  $\theta$  when velocity of hemisphere has become  $v$  is

A.  $\frac{5v}{R\cos\theta}$

B.  $\frac{2v}{R\cos\theta}$

C.  $\frac{3v}{R\sin\theta}$

D.  $\frac{5v}{R\sin\theta}$



[Watch Video Solution](#)

3. Two blocks A and B of mass  $m$  and  $2m$  respectively are connected by a light spring of force constant  $k$ . They are placed on a smooth horizontal surface. Spring is stretched by a length  $x$  and then released. Find the



relative velocity of the blocks when the spring comes to its natural length

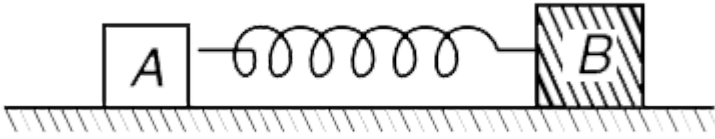

A.  $\left(\sqrt{\frac{3k}{2m}}\right)x$

B.  $\left(\sqrt{\frac{2k}{3m}}\right)x$

C.  $\sqrt{\frac{2kx}{m}}$

D.  $\sqrt{\frac{3km}{2x}}$



**Watch Video Solution**

4. A ball of mass  $m$  approaches a heavy wall of mass  $M$  with speed  $4 \text{ m/s}$  along the normal to the wall. The speed of wall before collision is  $1 \text{ m/s}$  towards the ball. The ball collides elastically with the wall. What can you say about the speed of the ball after collision? Will it be slightly less than or slightly higher than  $6 \text{ m/s}$  ?

A. 5 m/s away from the wall

B. 9 m/s away from the wall

C. 3 m/s away from the wall

D. 6 m/s away from the wall



**Watch Video Solution**

5. A tennis ball bounces down a flight of stairs, striking each step in turn and rebounding to half to height of the step. The coefficient of restitution is

A.  $\frac{1}{2}$

B.  $\frac{1}{\sqrt{2}}$

C.  $\frac{1}{4}$

D. 1



Watch Video Solution

6. A gun fires a bullet. The barrel of the gun is inclined at an angle of  $45^\circ$  with horizontal. When the bullet leaves the barrel it will be travelling at an angle greater than  $45^\circ$  with the horizontal. Is this statement true or false?

A.  $45^\circ$

B. less than  $45^\circ$

C. more than  $45^\circ$

D. zero



Watch Video Solution

7. A small block of superdense material has a mass  $\frac{M}{3}$ , where  $M$  is the mass of earth. It is released from rest from a height  $h$  ( $h < <$  radius of earth) from the surface of earth. The speed of the block at a height  $\frac{h}{2}$  is

A.  $\sqrt{gh}$

B.  $\frac{\sqrt{(3gh)}}{2}$

C.  $\sqrt{\frac{2gh}{3}}$

D.  $\sqrt{2gh}$

[Watch Video Solution](#)

8. A block of mass  $m$  is pushed towards a movable wedge of mass  $nm$  and height  $h$ , with a velocity  $u$ . All surfaces are smooth. The minimum value of  $u$  for which the block will reach the top of the wedge is

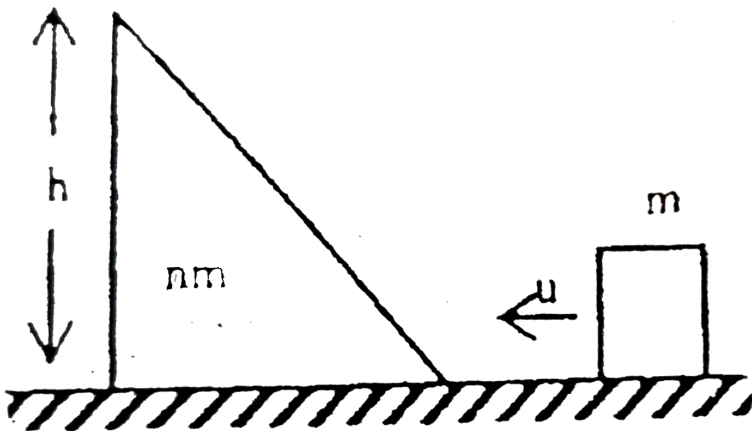

A.  $2\sqrt{gh}$

B.  $\sqrt{3gh}$

C.  $\sqrt{6gh}$

D.  $\sqrt{\frac{3}{2}gh}$



[Watch Video Solution](#)

9. A block of mass  $m$  slides down on inclined wedge of same mass  $m$  as shown in figure . Friction is absent everywhere . Acceleration of centre of

mass of the block and wedge is

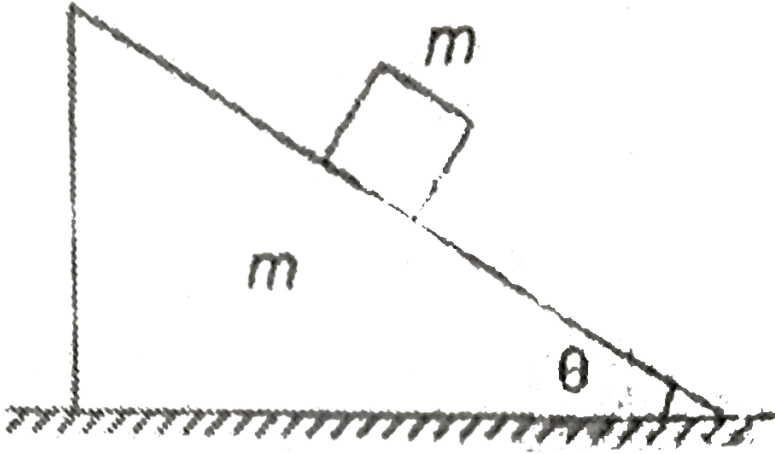

A. zero

B.  $\frac{g \sin^2 \theta}{(1 + \sin^2 \theta)}$

C.  $\frac{g \cos^2 \theta}{(1 + \sin^2 \theta)}$

D.  $\frac{g \sin \theta}{(1 + \cos \theta)}$



Watch Video Solution

10. A block A slides over another block B which is placed over a smooth inclined plane as shown in figure . The coefficient of friction between the two blocks A and B is  $\mu$  . Mass of block B is two times the mass of block A . The acceleration of the centre of mass of two blocks is

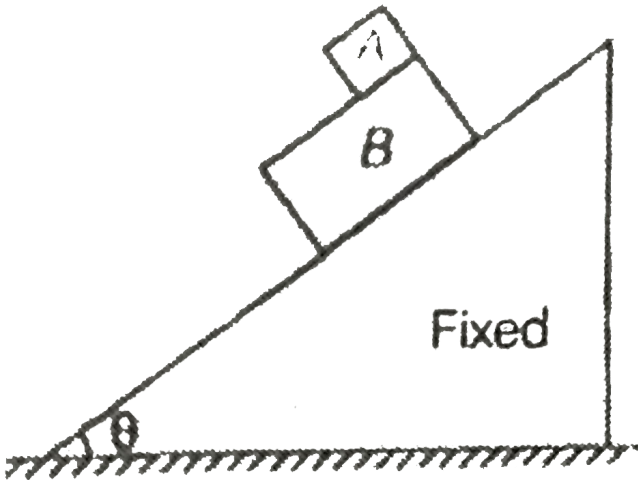

- A.  $g \sin \theta$
- B.  $\frac{g \sin \theta - \mu g \cos \theta}{3}$
- C.  $\frac{g \sin \theta}{3}$
- D.  $\frac{2g \sin \theta - \mu g \cos \theta}{3}$



Watch Video Solution

11. The momentum of a particle is  $P = A + Bt^2$ . Where , A and B are constant perpendicular vectors . The force acting on the particle when its acceleration is at  $45^\circ$  with its velocity is

A.  $2\sqrt{\frac{A}{B}}B$

B.  $2B$

C. zero

D.  $2A$



[Watch Video Solution](#)

12. Two blocks A and B of equal masses are attached to a string passing over a smooth pulley fixed to a wedge as shown in figure. Find the magnitude of acceleration of centre of mass of the two blocks when they



are released from rest. Neglect friction.

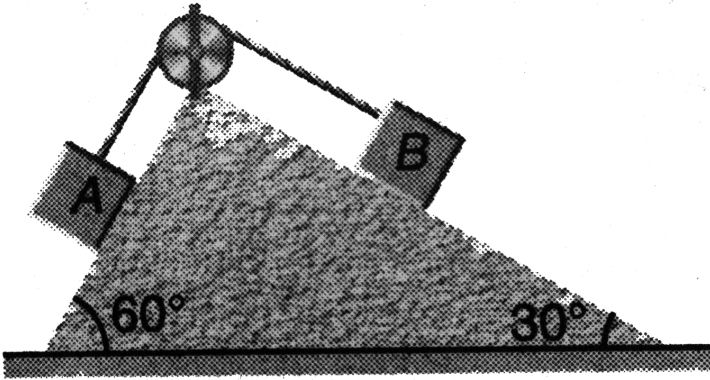

**Fig. 11.23**

A.  $\left(\frac{\sqrt{3}-1}{4\sqrt{2}}g\right)$

B.  $(\sqrt{3}-1)g$

C.  $\frac{g}{2}$

D.  $\left(\frac{\sqrt{3}-1}{\sqrt{2}}g\right)$



[Watch Video Solution](#)

**13.** A rope thrown over a pulley has a ladder with a man of mass  $m$  on one of its ends and a counter balancing mass  $M$  on its other end. The man

climbs with a velocity  $v_r$  relative to ladder. Ignoring the masses of the pulley and the rope as well as the friction on the pulley axis, the velocity of the centre of mass of this system is:

- A.  $\frac{m}{M}v_r$
- B.  $\frac{m}{2M}v_r$
- C.  $\frac{M}{m}v_r$
- D.  $\frac{2M}{m}v_r$



Watch Video Solution

14. Two particles of equal mass have velocities  $\vec{v}_1 = 2\hat{i} = m/s^{-1}$  and  $\vec{v}_2 = 2\hat{j}m/s^{-1}$ . First particle has an acceleration  $\vec{a}_1 = (3\hat{i} + 3\hat{j})ms^{-2}$  while the acceleration of the other particle is zero. The centre of mass of the two particles moves in a path of.

- A. circle
- B. parabola

C. straight line

D. ellipse

 [Watch Video Solution](#)

15. A particle of mass  $2m$  is projected at an angle of  $45^\circ$  with horizontal with a velocity of  $20\sqrt{2}m/s$ . After  $1s$  explosion takes place and the particle is broken into two equal pieces. As a result of explosion one part comes to rest. Find the maximum height attained by the other part. Take  $g = 10m/s^2$ .

A. 50 m

B. 25 m

C. 40 m

D. 35 m

 [Watch Video Solution](#)

16. A system of two blocks A and B and a wedge C are released from rest as shown in figure . Masses of the blocks and the wedge are  $m$  ,  $2m$  and  $2m$  respectively . The displacement of wedge C when block B slides down the plane a distance 10 cm is ( neglect friction )

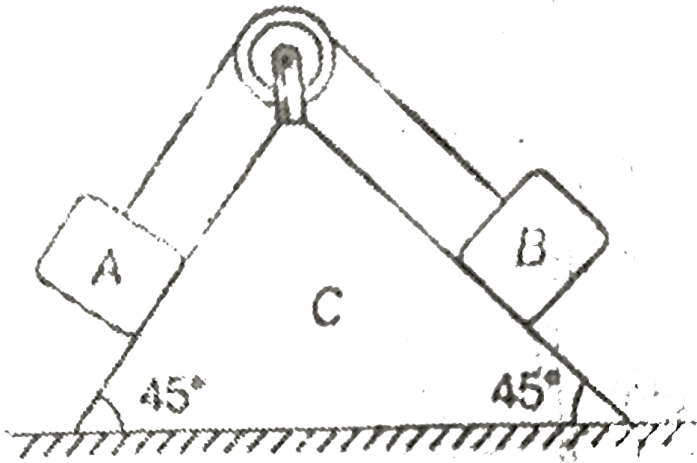

A.  $5\sqrt{2}$  cm

B.  $3\sqrt{2}$  cm

C. 4 cm

D.  $\frac{5}{\sqrt{2}}$  cm



Watch Video Solution

17. A small sphere of radius  $R$  is held against the inner surface of larger sphere of radius  $6R$  (as shown in figure). The masses of large and small spheres are  $4M$  and  $M$  respectively. This arrangement is placed on a horizontal table. There is no friction between any surfaces of contact. The small sphere is now released. Find the coordinates of the centre of the large sphere, when the smaller sphere reaches the other extreme position.

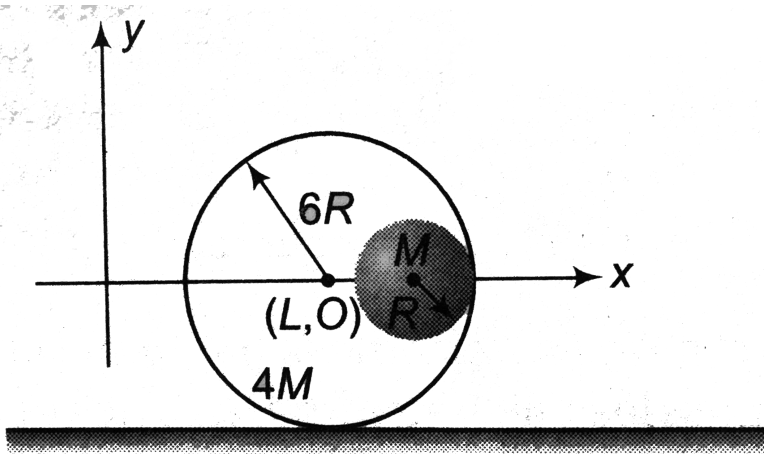

A. R

B. 2R

C. 3R

D. 4R



[Watch Video Solution](#)

**18.** A block of mass  $m$  slides over a smooth wedge of mass  $M$  which is placed over a rough horizontal surface . The centre of mass of the system will move towards left

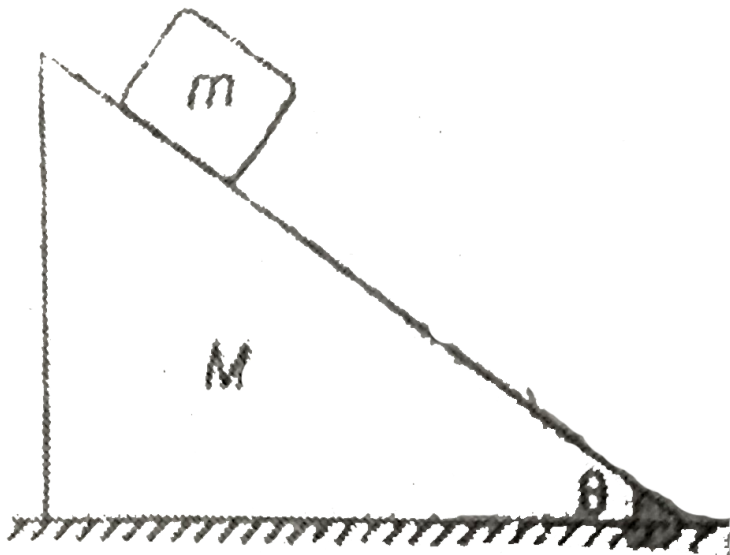

Here  $\mu$  = coefficient of friction between the wedge and the ground .

A. if  $mg \cos \theta \sin \theta > \mu(M + m)g$

B. if  $mg \sin \theta > \mu Mg$

C. if  $mg \cos \theta \sin \theta > \mu Mg$

D. None of the above



[Watch Video Solution](#)

19. Two particles  $A$  and  $B$  of equal mass  $m$  are attached by a string of length  $2l$  and initially placed over a smooth horizontal table in the position shown in fig. particle  $B$  is projected across the table with speed  $u$  perpendicular to  $AB$  as shown in the figure. find the velocities of each particle after the string becomes taut and the magnitude of the impulse



tension.

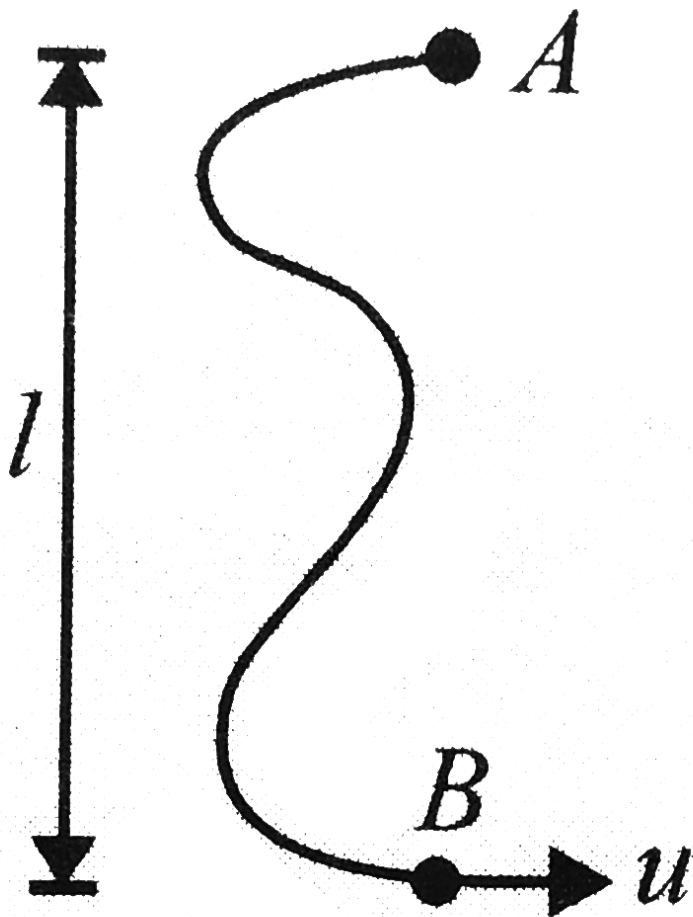

A.  $\frac{u\sqrt{3}}{4}$

B.  $u\sqrt{3}$

C.  $\frac{u\sqrt{3}}{2}$

D.  $\frac{u}{2}$



Watch Video Solution

**20.** A mass  $m$  rests on a horizontal table. It is attached to a light inextensible string which passes over a smooth pulley and carries a mass  $m$  at the other end. If the mass  $m$  is raised vertically through a distance  $h$  and is then dropped, what is the speed with which the mass  $2m$  begins to

rise?

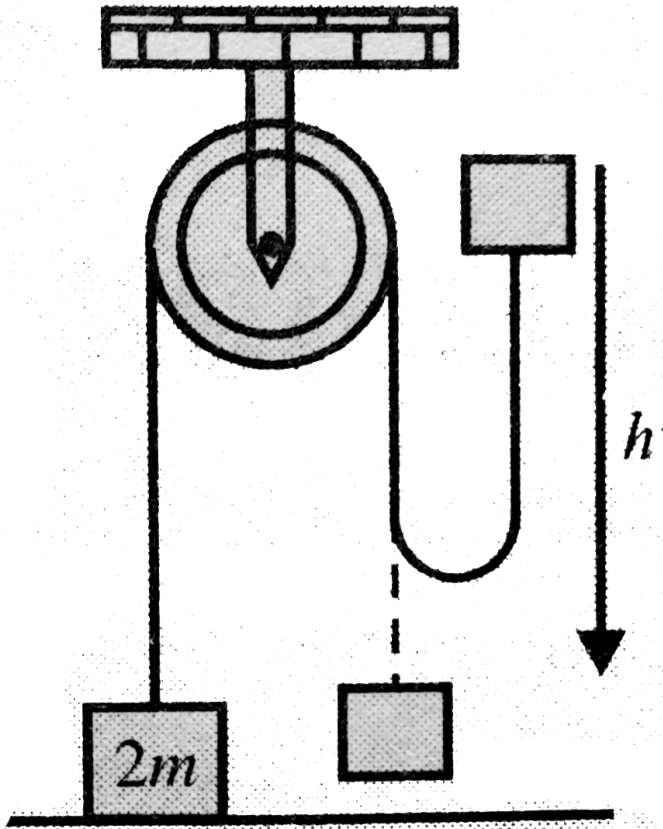

- A.  $\sqrt{2gh}$
- B.  $\frac{\sqrt{2gh}}{3}$
- C.  $\frac{\sqrt{gh}}{2}$
- D.  $\sqrt{gh}$



Watch Video Solution

21. Two identical balls  $A$  and  $B$  are released from the position shown in Fig. They collide elastically with each other on the horizontal portion. The ratio of heights attained by  $A$  and  $B$  after collision is (neglect friction)

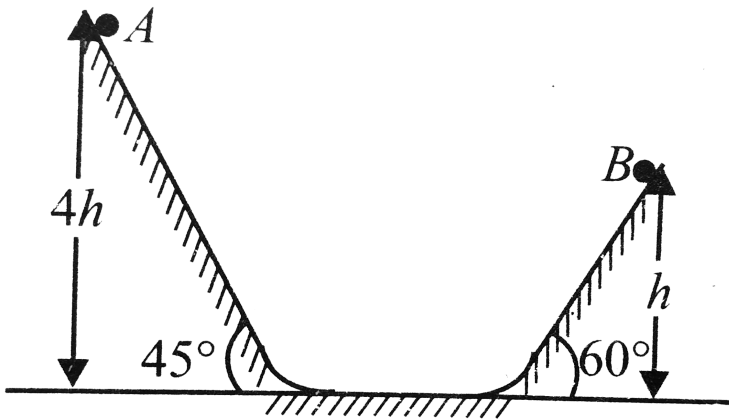

- A. 1:4
- B. 2:1
- C. 4:13
- D. 2:5



[Watch Video Solution](#)

22. A small block of mass  $M$  moves with velocity  $5 \text{ m/s}$  towards an another block of same mass  $M$  placed at a distance of  $2 \text{ m}$  on a rough horizontal surface . Coefficient of friction between the blocks and ground is  $0.25$  . Collision between the two blocks is elastic , the separation between the blocks , when both of them come to rest , is (  $g = 10 \text{ m/s}^2$  )

A.  $3 \text{ m}$

B.  $4 \text{ m}$

C.  $2 \text{ m}$

D.  $1.5 \text{ m}$



[Watch Video Solution](#)

23. A gun fires a shell and recoils horizontally . If the shell travels along the barrel with speed  $v$  , the ratio of speed with which the gun recoils if (i)

the barrel is horizontal (ii) inclined at an angle of  $30^\circ$  with horizontal is

A. 1

B.  $\frac{2}{\sqrt{3}}$

C.  $\frac{\sqrt{3}}{2}$

D.  $\frac{1}{2}$



Watch Video Solution

**24.** A body of mass  $m_0$  is placed on a smooth horizontal surface . The mass of the body is decreasing exponentially with disintegration constant ,  $\lambda$  . Assuming that the mass is ejected backwards with a relative velocity  $u$  . If initially the body was at rest , the speed of body at time  $t$  is

A.  $ue^{\lambda t}$

B.  $u\lambda t$

C.  $ue^{-\lambda t}$

D.  $u(1 - e^{-\lambda t})$



[Watch Video Solution](#)

25. A balloon has 2 g of air . A small hole is pierced into it . The air comes out with relative velocity 4 m/s . If the balloon shrinks completely in 2.5 s , the average force acting on the balloon is

A.  $0.008N$

B.  $0.0032 N$

C.  $8 N$

D.  $3.2 N$



[Watch Video Solution](#)

26. In a one-dimensional collision between two identical particles. A and B, B is stationary and A has momentum  $p$  before impact. During impact, B gives an impulse  $J$  to A. Find the coefficient of restitution between A and B?

A.  $\frac{2J}{P} - 1$

B.  $\frac{2J}{P} + 1$

C.  $\frac{J}{P} + 1$

D.  $\frac{J}{P} - 1$



Watch Video Solution

27. A ball A is falling vertically downwards with velocity  $v_1$ . It strikes elastically with a wedge moving horizontally with velocity  $v_2$  as shown in figure. What must be the ratio  $\frac{v_1}{v_2}$ , so that the ball bounces back in



vertically upward direction relative to the wedge

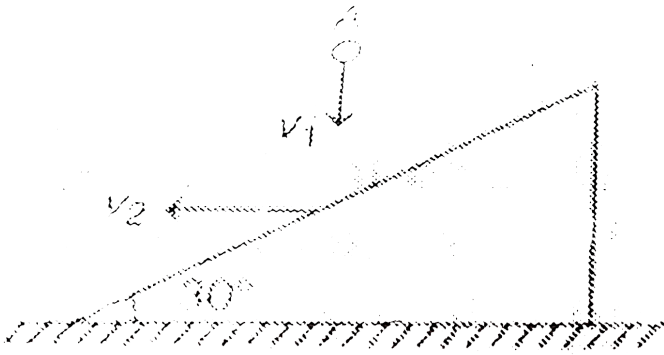

A.  $\sqrt{3}$

B.  $\frac{1}{\sqrt{3}}$

C. 2

D.  $\frac{1}{2}$



Watch Video Solution

28. A ball is projected from the point O with velocity  $20 \text{ m/s}$  at an angle of  $60^\circ$  with horizontal as shown in figure. At highest point of its trajectory it strikes a smooth plane of inclination  $30^\circ$  at point A. The

collision is perfectly inelastic. The maximum height from the ground attained by the ball is ( $g = 10\text{ m/s}^2$ )

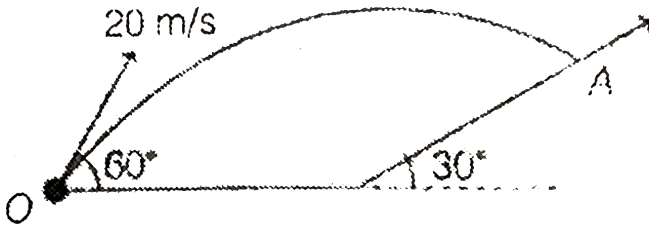

- A. 18.75m
- B. 15 m
- C. 22.5 m
- D. 20.25 m



[Watch Video Solution](#)

**29.** A bullet of mass ' $m$ ' moving with velocity ' $u$ ' passes through a wooden block of mass  $M = nm$  as shown in figure. The block is resting on a smooth horizontal floor. After passing through the block, velocity relative

to the block is

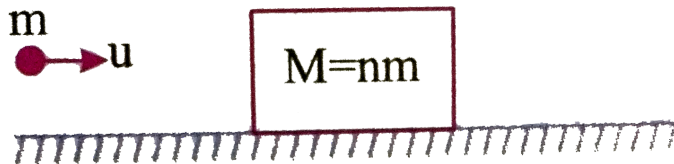

A.  $\frac{(1+n)v - u}{n}$

B.  $\frac{nv - u}{n + 1}$

C.  $\frac{nu - v}{n + 1}$

D.  $\frac{(1+n)v + u}{2n + 1}$

 [Watch Video Solution](#)

**30.** A ball of mass  $m$  collides with the ground at an angle. With the vertical. If the collision lasts for time  $t$ , the average force exerted by the ground on the ball is : ( $e$  = coefficient of restitution between the ball and

the ground)

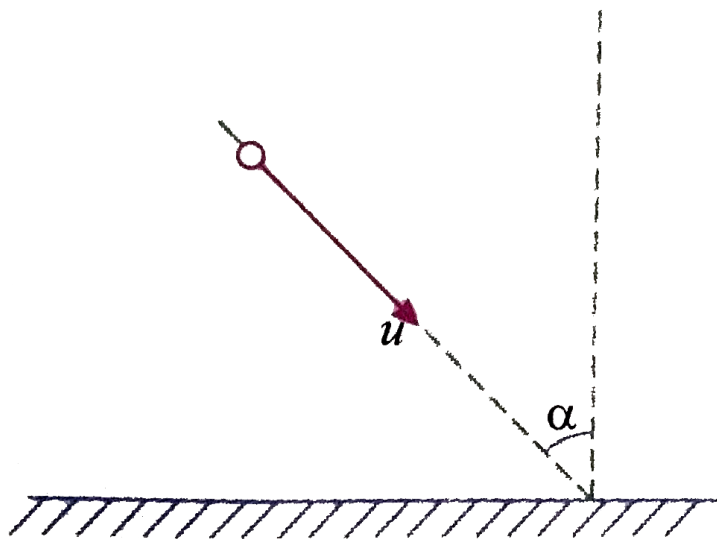

- A.  $\frac{emu \cos \alpha}{t}$
- B.  $\frac{2(1 + e)mu \cos \alpha}{t}$
- C.  $\frac{(1 + e)mu \cos \alpha}{t}$
- D.  $\frac{emu}{t}$



Watch Video Solution

31. A small ball falling vertically downward with constant velocity  $2m/s$  strikes elastically an inclined plane moving with velocity  $2m/s$  as shown in figure. The velocity of rebound of the ball with respect ground is

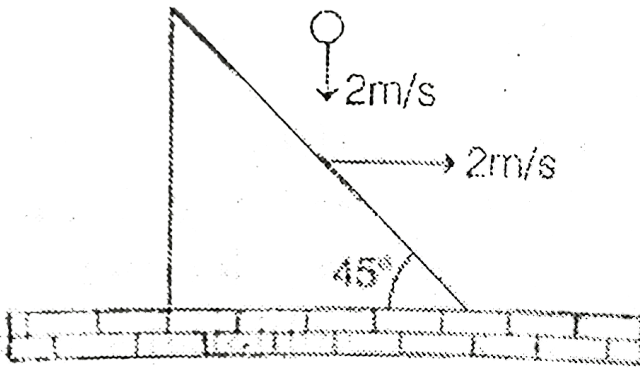

- A.  $4m/s$
- B.  $2\sqrt{5}m/s$
- C.  $2\sqrt{2}m/s$
- D.  $2m/s$



Watch Video Solution

32. Two blocks of mass  $m$  and  $2m$  are kept on a smooth horizontal surface. They are connected by an ideal spring of force constant  $k$ . Initially the spring is unstretched. A constant force is applied to the heavier block in the direction shown in figure. Suppose at time  $t$  displacement of smaller block is  $x_1$  then displacement of the heavier block at this moment would be

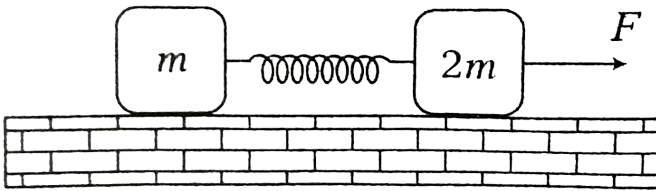

- A.  $\frac{x}{2}$
- B.  $\frac{Ft^2}{6m} + \frac{x}{3}$
- C.  $\frac{x}{3}$
- D.  $\frac{Ft^2}{4m} - \frac{x}{2}$



Watch Video Solution

**33.** Blocks A and B shown in the figure are having equal masses  $m$ . The system is released from rest with the spring unstretched. The string between A and ground is cut, when there is maximum extension in the spring. The acceleration of centre of mass of the two blocks at this

instant is

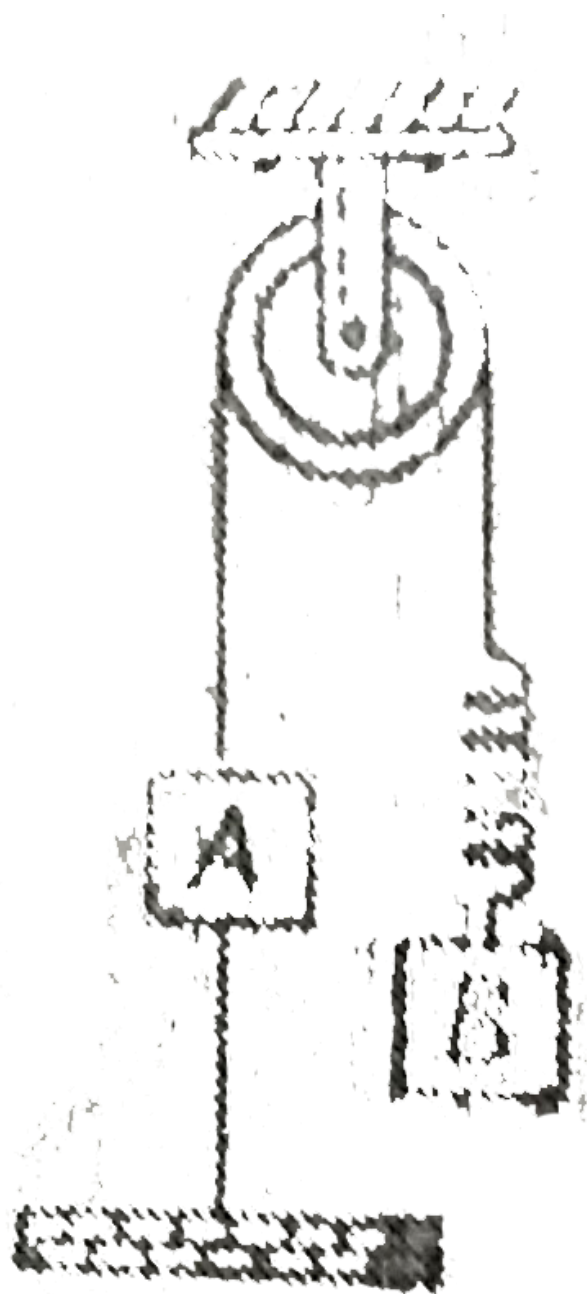



A.  $g$

B.  $\frac{g}{2}$

C.  $2g$

D. zero

 Watch Video Solution

34. Both the blocks as shown in figure are given together a horizontal velocity towards right. The acceleration of the centre of mass of the system of block is ( $m_A = 2m_B = 2kg$ ).

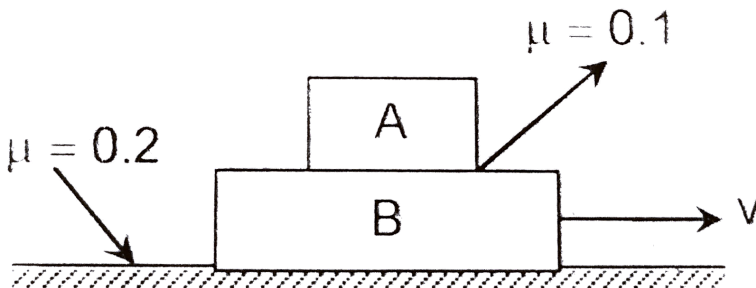

A. zero

B.  $5/3m / s^2$

C.  $7/3m / s^2$

D.  $2m / s^2$



Watch Video Solution

35. A particle of mass  $3m$  is projected from the ground at some angle with horizontal. Its horizontal range is  $R$ . At the highest point of its path it breaks into two pieces of masses  $m$  and  $2m$  respectively. The smaller mass comes to rest. The larger mass finally falls at a distance  $x$  from the point of projection where  $x$  is equal to

A.  $\frac{4}{3}R$

B.  $\frac{3}{2}R$

C.  $\frac{5}{4}R$

D.  $2.5R$



Watch Video Solution

36. A girl throws a ball with an initial velocity  $v$  at an angle  $45^\circ$ . The ball strikes a smooth vertical wall at a horizontal distance  $d$  from the girl and after rebound returns to her hands. What is the coefficient of restitution between wall and ball ? ( $v^2 > dg$ )

A.  $v^2 - gd$

B.  $\frac{gd}{v^2 - gd}$

C.  $\frac{gd}{v^2}$

D.  $\frac{v^2}{gd}$



Watch Video Solution

37. A ball collides at  $B$  with velocity  $10m/s$  at  $30^\circ$  with vertical. There is a flag at  $A$  and a will at  $C$ . Collision of ball with ground is perfectly inelastic

( $e = 0$ ) and that with wall is elastic ( $e = 1$ ). Given  $AB = BC = 10m$ .

Find the time after which ball will collide with the flag.

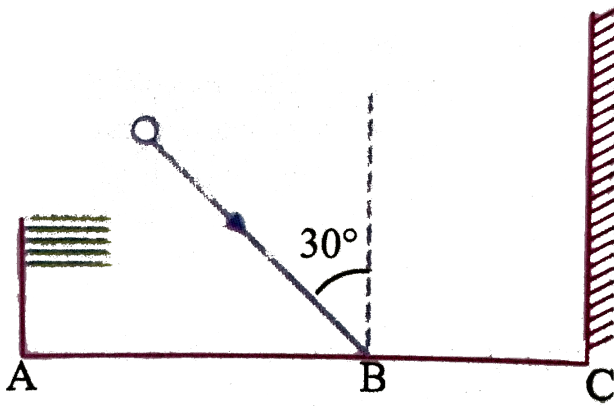

A. 4

B. 5

C. 6

D. ball will not collide with the flag



Watch Video Solution

38. The lower end of a 4 m long uniform rod AB is pulled with constant speed  $v=4 \text{ m/s}$ . The speed of centre of mass of the rod at  $\theta = 60^\circ$  will be

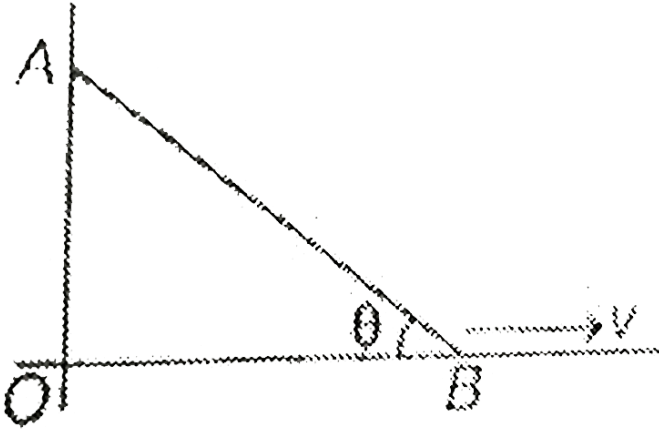

- A.  $\frac{4}{\sqrt{3}} \text{ m/s}$
- B.  $2\sqrt{3} \text{ m/s}$
- C.  $4 \text{ m/s}$
- D.  $4\sqrt{3} \text{ m/s}$



Watch Video Solution

39. A rigid rod leans against a vertical wall (y-axis) as shown in figure. The other end of the rod is on the horizontal floor. Point A is pushed downwards with constant velocity. Path of the centre of the rod is

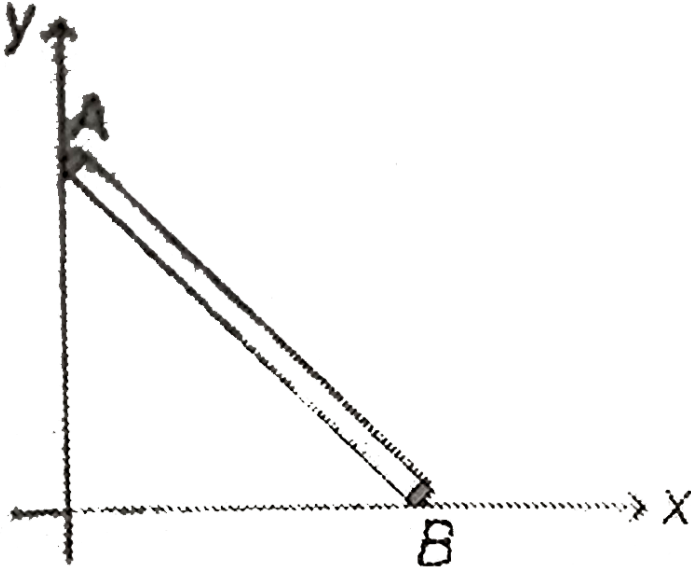

- A. a parabola
- B. an ellipse
- C. a circle of radius  $l/2$  and centre at origin
- D. a circle of radius  $l/2$  but centre not at origin



**40.** A bullet of mass  $m$  moving vertically upwards instantaneously with a velocity ' $u$ ' hits the hanging block of mass ' $m$ ' and gets embedded in it, as shown in the figure. The height through which the block rises after the

collision. (assume sufficient space above block) is:

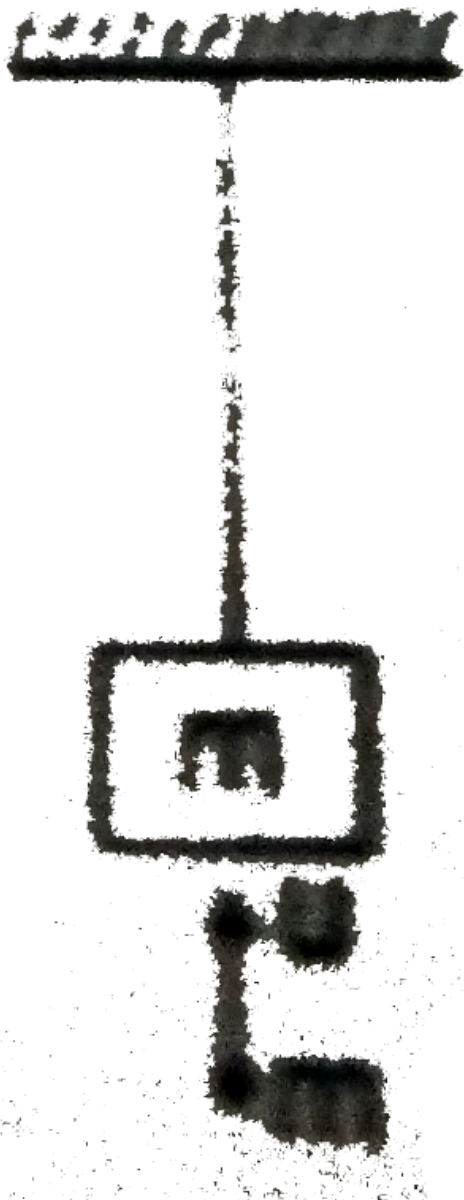

A.  $u^2 / 2g$



B.  $u^2 / g$

C.  $u^2 / 8g$

D.  $u^2 / 4g$



Watch Video Solution

41. A super-ball of mass  $m$  is to bounce elastically back and forth between two rigid walls at a distance  $d$  from each other. Neglecting gravity and assuming the velocity of super-ball to be  $v_0$  horizontally, the average force being exerted by the super-ball on each wall is

A.  $\frac{1}{2} \frac{mv_0^2}{d}$

B.  $\frac{mv_0^2}{d}$

C.  $\frac{2mv_0^2}{d}$

D.  $\frac{4mv_0^2}{d}$



Watch Video Solution

42. A block of mass  $M$  with a semicircular of radius  $R$ , rests on a horizontal frictionless surface. A uniform cylinder of radius  $r$  and mass  $m$  is released from rest the top point A. The cylinder slips on the semicircular frictionless track. How far has the block moved when the cylinder reaches the bottom (point B) of the track? How fast is the block moving when the cylinder reaches the bottom of the track?

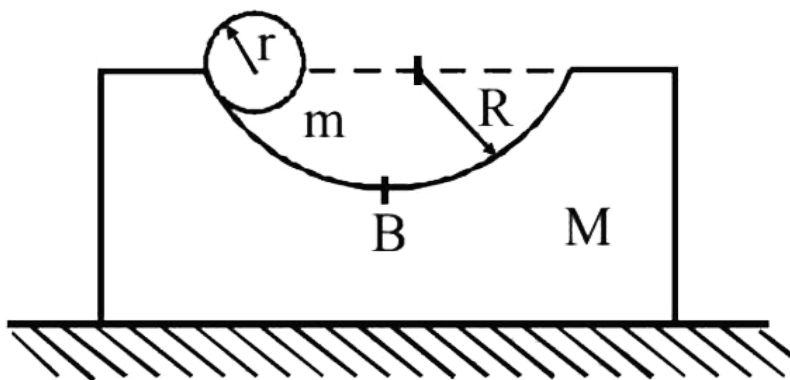

- A.  $\frac{M(R - r)}{M + m}$
- B.  $\frac{m(R - r)}{M + m}$
- C.  $\frac{(M + m)R}{M}$

D. None of these

 [Watch Video Solution](#)

**43.** A block of mass  $M$  with a semicircular of radius  $R$ , rests on a horizontal frictionless surface. A uniform cylinder of radius  $r$  and mass  $m$  is released from rest the top point A. The cylinder slips on the semicircular frictionless track. How far has the block moved when the cylinder reaches the bottom (point B) of the track? How fast is the block moving when the cylinder reaches the bottom of the track?

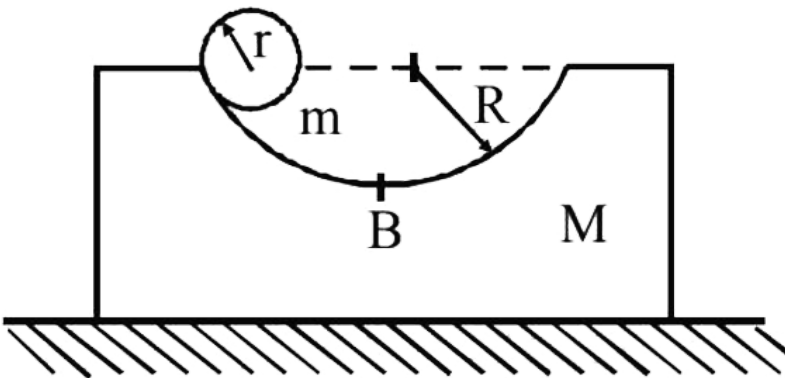

$$\text{A. } M \sqrt{\frac{2g(R - r)}{M(M + m)}}$$

$$\text{B. } m \sqrt{\frac{2g(R - r)}{m(M + m)}}$$

$$\text{C. } m \sqrt{\frac{2g(R - r)}{M(M + m)}}$$

$$\text{D. } M \sqrt{\frac{2g(R + r)}{M(M + m)}}$$



Watch Video Solution

**44.** A skater of mass  $m$  standing on ice throws a stone of mass  $M$  with a velocity of  $v$  in a horizontal direction. The distance over which the skater will move back (the coefficient of friction between the skater and the ice is  $\mu$ )

$$\text{A. } \frac{M^2 V^2}{2m\mu g}$$

$$\text{B. } \frac{MV^2}{2m^2\mu g}$$

$$\text{C. } \frac{M^2 V^2}{2m^2\mu g}$$

$$\text{D. } \frac{M^2 V^2}{2m^2\mu^2 g}$$



Watch Video Solution

45. A small ball on a frictionless horizontal surface moves towards right with velocity  $v$ . It collides with the wall and returns back and continues to and fro motion. If the average speed for first to and fro motion of the ball is  $\left(\frac{2}{3}\right)v$ , then the coefficient of restitution of impact is

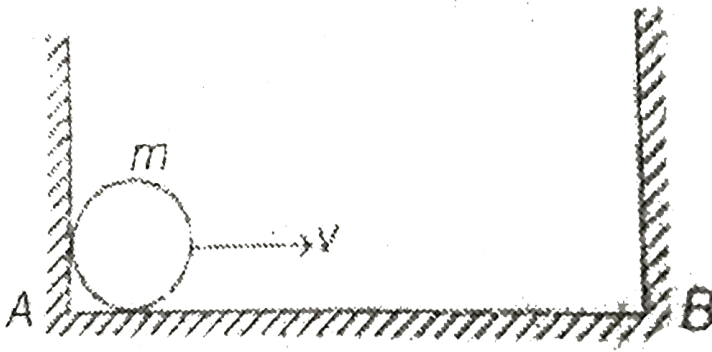

- A. 0.5
- B. 0.8
- C. 0.25
- D. 0.75



Watch Video Solution

46. A body of mass  $m$  is dropped from a height of  $h$ . Simultaneously another body of mass  $2m$  is thrown up vertically with such a velocity  $v$  that they collide at height  $\frac{h}{2}$ . If the collision is perfectly inelastic, the velocity of combined mass at the time of collision with the ground will be

A.  $\sqrt{\frac{5gh}{4}}$

B.  $\sqrt{gh}$

C.  $\sqrt{\frac{gh}{4}}$

D.  $\sqrt{\frac{13gh}{9}}$



Watch Video Solution

47. Two bars of masses  $m_1$  and  $m_2$  connected by a weightless spring of stiffness  $k$ , rest on a smooth horizontal plane. Bar 2 is shifted by a small distance  $x_0$  to the left and released. The velocity of the centre of mass of the system when bar 1 breaks off the wall is

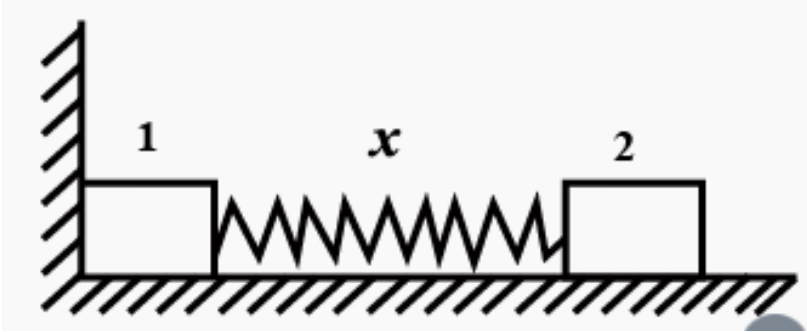

- A.  $\frac{x\sqrt{m_2k}}{m_1 + m_2}$
- B.  $x\sqrt{\frac{K}{m_1 + m_2}}$
- C.  $\frac{x\sqrt{m_1k}}{m_1 + m_2}$
- D.  $\frac{\sqrt{m_1k}}{m_1 + m_2}$



Watch Video Solution

48. A rocket is projected vertically upwards. It explodes at the topmost point of its trajectory into three identical fragments. One of the fragments comes straight down in time  $t_1$  while the other two land at a time  $t_2$  after explosion. Find the height at which the explosion occurred in terms of  $t_1$  and  $t_2$ ?

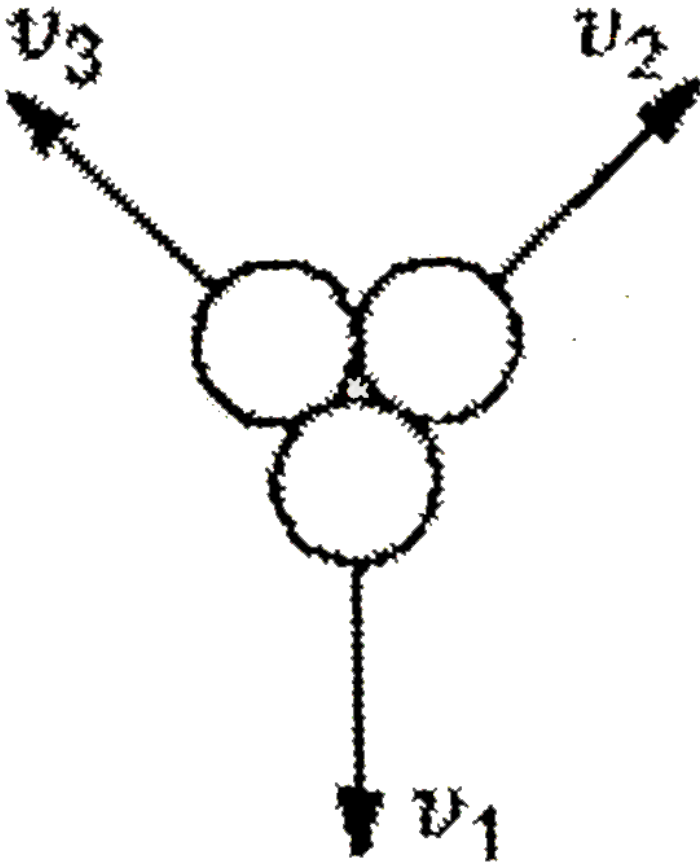

A. 
$$\frac{gt_1 t_2 (t_2 + 3t_1)}{2(t_1 + t_2)}$$



B.  $\frac{gt_1 t_2^2}{2t_3}$

C.  $\frac{gt_1 t_2 (t_1 + 2t_2)}{2(2t_1 + t_2)}$

D.  $\frac{gt_1 t_2 (2t_1 + t_2)}{4(t_1 + 2t_2)}$

 [Watch Video Solution](#)

49. A raindrop as it falls through fog or mist collects mass at a uniform rate. The drop starts from rest with zero radius and remains spherical at all times. The acceleration with which it falls

A. is constant and equal to  $g/2$

B. is constant and equal to  $g/3$

C. increases with time

D. decreases with time

 [Watch Video Solution](#)

50. A small block of mass 'm' is placed on bigger block of mass  $M_1$  which is placed on a frictionless horizontal surface. The two blocks are given equal speed  $u_1$  but opposite directions, as shown in the figure. After sometime, it is observed that both blocks are moving in the direction of motion of the lower block, with a speed greater than  $\frac{u}{2}$ . It can be concluded that -

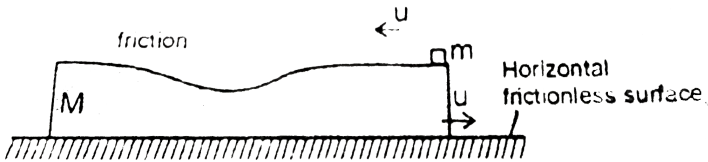

A.  $M > 3m$

B.  $3M < m$

C.  $m > 2M$

D. M and m can have any value such that  $M > m$



Watch Video Solution

51. A trolley is moving horizontally with a constant velocity of  $v_m/s$  w.r.t. earth. A man starts running from one end of the trolley with velocity  $1.5v_m/s$  w.r.t. to trolley. After reaching the opposite end, the man return back and continues running with a velocity of  $1.5v_m/s$  w.r.t. the trolley in the backward direction. If the length of the trolley is  $L$  then the displacement of the man with respect to earth during the process will be

:-

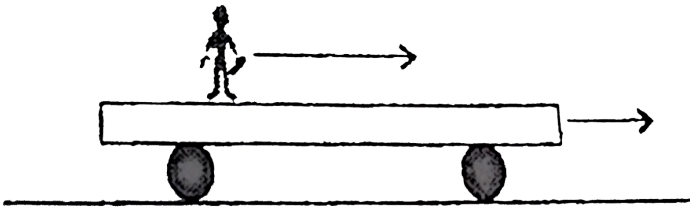

A.  $\frac{4}{3}L$

B.  $\frac{2}{3}L$

C.  $\frac{5L}{3}$

D.  $1.5L$



Watch Video Solution

52. A bullet of mass  $m$  penetrates a thickness  $h$  of a fixed plate of mass  $M$ . If the plate was free to move, then the thickness penetrated will be

A.  $\frac{SM}{m}$

B.  $\frac{Sm}{M + m}$

C.  $\frac{SM}{M + m}$

D.  $\frac{SM}{M}$



Watch Video Solution

53. A small particle is placed at the top point A of a fixed smooth hemisphere of radius R. Particle is given small displacement towards right and it starts slipping. Calculate velocity of the particle after hitting

horizontal

perfectly

inelastic

surface.

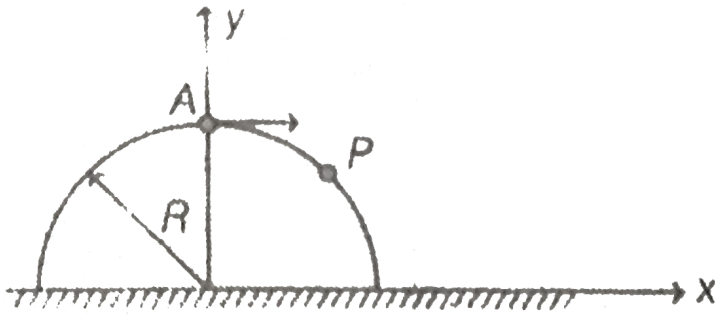

A.  $\sqrt{gR}$

B.  $\sqrt{\frac{2}{3}gR}$

C.  $\frac{2}{3}\sqrt{\frac{2}{3}gR}$

D.  $\sqrt{\frac{gR}{3}}$



Watch Video Solution

54. Three masses A, B and C are kept on a smooth horizontal surface as shown in the figure. A sharp impulse is given to the mass A, so that it starts moving towards B with speed  $v_0$ . What is the minimum value of m

so that there is only one collision between masses A and B (all collisions are elastic)

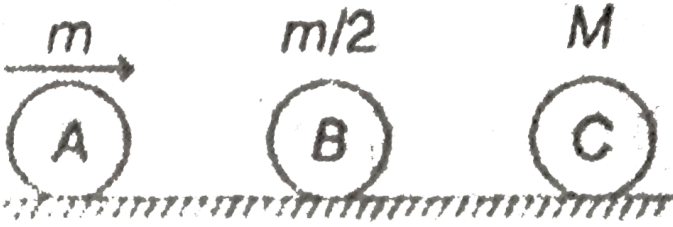

A.  $M$

B.  $\frac{10M}{3}$

C.  $\frac{8M}{3}$

D.  $(2M)$

[Watch Video Solution](#)

55. A block of mass  $m$  is attached with a spring of force constant  $k$ . The block is kept on a frictionless plank. Mass of the plank is  $M$  and it is also kept on a horizontal frictionless surface. Initially the system is stationary. An impulse  $p$  is applied on the block as shown. The maximum

compression

in

the

spring

will

be

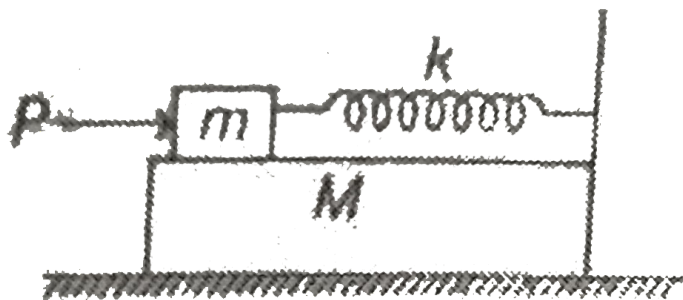

Frictionless surface

- A.  $\sqrt{\frac{MP^2}{m(M+m)k}}$
- B.  $\sqrt{\frac{mP^2}{M(M+m)k}}$
- C.  $\sqrt{\frac{MP^2}{m^2k}}$
- D.  $\sqrt{\frac{MP^2}{M^2k}}$



Watch Video Solution

More than one option is Correct

1. A ball mass 2 kg moving horizontally with velocity 10 m/s hits a wedge of mass 5 kg placed on a horizontal surface as shown in the figure. Just after collision the velocity of wedge is 3.2 m/s. There is no friction at any contact surface. Then (take  $\sin 30^\circ = 3/5$ )

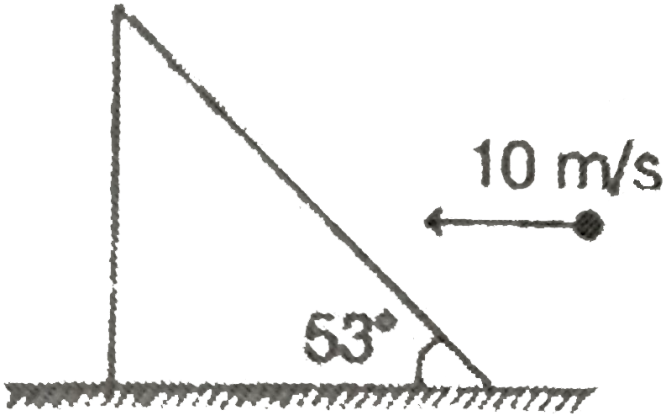

- A. Speed of ball just collision is  $2\sqrt{10}$  m/s
- B. Impulse applied by ball on the wedge during collision is 20 N-s
- C. Both are correct
- D. Both are wrong



## Comprehension type questions

### 1. Comprehension # 1

If net force on a system in a particular direction is zero (say in horizontal direction), we can apply:  $\Sigma m_R x_R = \Sigma m_L x_L, \Sigma m_R v_R = \Sigma m_L v_L$  and

$$\Sigma m_R a_R = \Sigma m_L a_L$$

Here  $R$  stands for the masses which are moving towards right and  $L$  for the masses towards left,  $x$  is displacement,  $v$  is velocity and  $a$  the acceleration (all with respect to ground).

A small block of mass  $m = 1\text{kg}$  is placed over a wedge of mass  $M = 4\text{kg}$  as shown in figure. Mass  $m$  is released from rest. All surface are smooth.

Origin  $O$  is as shown.

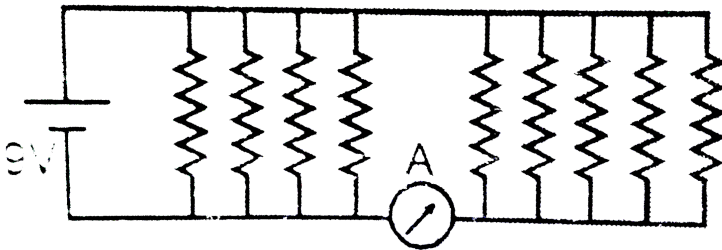

Final velocity of the wedge is ..... $m/s$  :-

A.  $\sqrt{3}$

B.  $\sqrt{2}$

C.  $\frac{1}{\sqrt{2}}$

D.  $\frac{1}{\sqrt{3}}$



Watch Video Solution

## 2. Comprehension # 1

If net force on a system in a particular direction is zero (say in horizontal direction), we can apply:  $\Sigma m_R x_R = \Sigma m_L x_L, \Sigma m_R v_R = \Sigma m_L v_L$  and  $\Sigma m_R a_R = \Sigma m_L a_L$

Here  $R$  stands for the masses which are moving towards right and  $L$  for the masses towards left,  $x$  is displacement,  $v$  is velocity and  $a$  the acceleration (all with respect to ground).

A small block of mass  $m = 1\text{kg}$  is placed over a wedge of mass  $M = 4\text{kg}$  as shown in figure. Mass  $m$  is released from rest. All surface are smooth. Origin  $O$  is as shown.

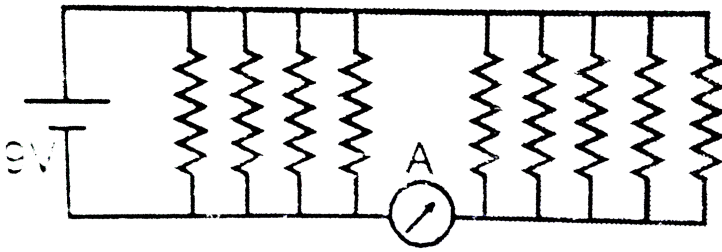

The block will strike the x-axis at  $x = \dots\dots\dots m$  :-

- A. 4.2
- B. 7.6
- C. 5.6
- D. 6.8

**Watch Video Solution**

### 3. Comprehension # 1

If net force on a system in a particular direction is zero (say in horizontal direction), we can apply:  $\Sigma m_R x_R = \Sigma m_L x_L, \Sigma m_R v_R = \Sigma m_L v_L$  and

$$\Sigma m_R a_R = \Sigma m_L a_L$$

Here  $R$  stands for the masses which are moving towards right and  $L$  for the masses towards left,  $x$  is displacement,  $v$  is velocity and  $a$  the acceleration (all with respect to ground).

A small block of mass  $m = 1\text{kg}$  is placed over a wedge of mass  $M = 4\text{kg}$  as shown in figure. Mass  $m$  is released from rest. All surface are smooth.

Origin  $O$  is as shown.

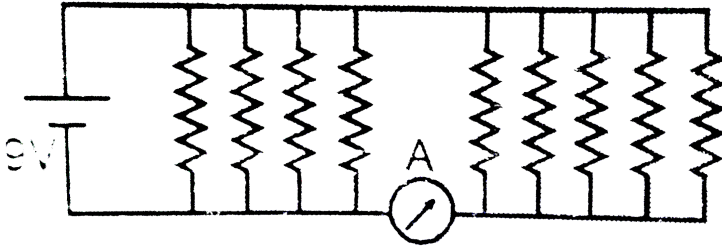

Normal reaction between the two blocks at an instant when absolute acceleration of  $m$  is  $5\sqrt{3}m/s^2$  at  $60^\circ$  with horizontal is ..... N. Normal reaction at this instant is making  $30^\circ$  with horizontal.

- A. 6
- B. 10
- C. 4
- D. 5



#### 4. Comprehension # 1

If net force on a system in a particular direction is zero (say in horizontal direction) we can apply:

$$\Sigma m_R x_R = \Sigma m_L x_L, \Sigma m_R v_R = \Sigma m_L v_L \text{ and } \Sigma m_R a_R = \Sigma m_L a_L$$

Here R stands for the masses which are moving towards right and L for the masses towards left,  $x$  is displacement,  $v$  is velocity and  $a$  the acceleration (all with respect to ground). A small block of mass  $m = 1\text{kg}$  is placed over a wedge of mass  $M = 4\text{kg}$  as shown in figure. Mass  $m$  is released from rest. All surface are smooth. Origin O is as shown.

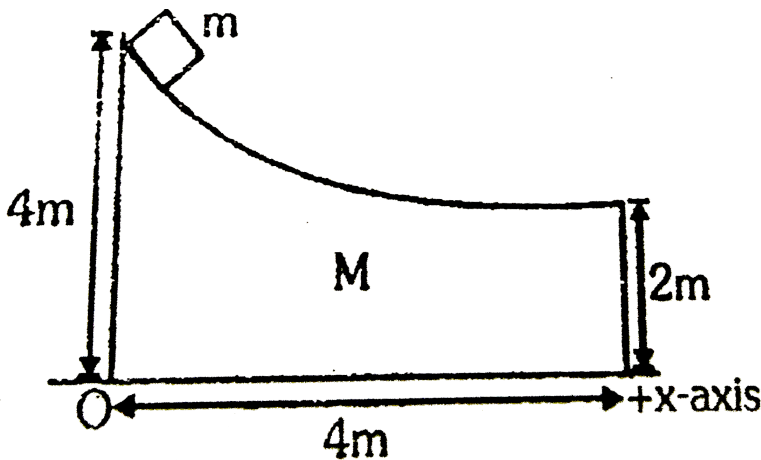

At the same instant reaction on the wedge from the ground is .....N.

A. 42.5

B. 40

C. 43.46

D. None of the above

 [Watch Video Solution](#)

### 5. Comprehension # 2

When two bodies collide normally they exert equal and opposite impulses on each other. Impulse = change in linear momentum. Coefficient of restitution between two bodies is given by :-

$$e = \frac{|\text{Relative velocity of separation}|}{|\text{Relative velocity of approach}|} = 1, \text{ for elastic collision.}$$

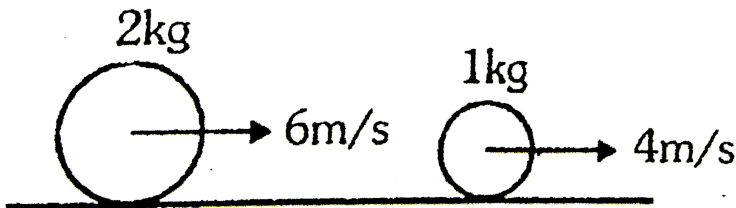

Two bodies collide as shown in figure. During collision they exert impulse

of magnitude  $J$  on each other.

If the collision is elastic, the value of  $J$  is .....  $Ns$ .

A.  $10/3$

B.  $5/4$

C.  $8/3$

D.  $3/2$



[Watch Video Solution](#)

## 6. Comprehension # 2

When two bodies collide normally they exert equal and opposite impulses on each other. Impulse = change in linear momentum. Coefficient of restitution between two bodies is given by :-

$$e = \frac{|\text{Relative velocity of separation}|}{|\text{Relative velocity of approach}|} = 1, \text{ for elastic collision}$$



Two bodies collide as shown in figure. During collision they exert impulse

of magnitude  $J$  on each other.

For what value of  $J$  (in  $Ns$ ) the  $2kg$  block will change its direction of velocity?

A.  $J < 12$

B.  $J > 12$

C.  $J < 10$

D.  $J > 10$



[Watch Video Solution](#)

7. Two identical masses are as shown in figure. One is thrown upwards with velocity  $20\text{ m/s}$  and another is just dropped simultaneously.

The masses collide in air and stick together. After how much time the combined mass will fall to the ground (calculate the time from the



starting when the motion was started )

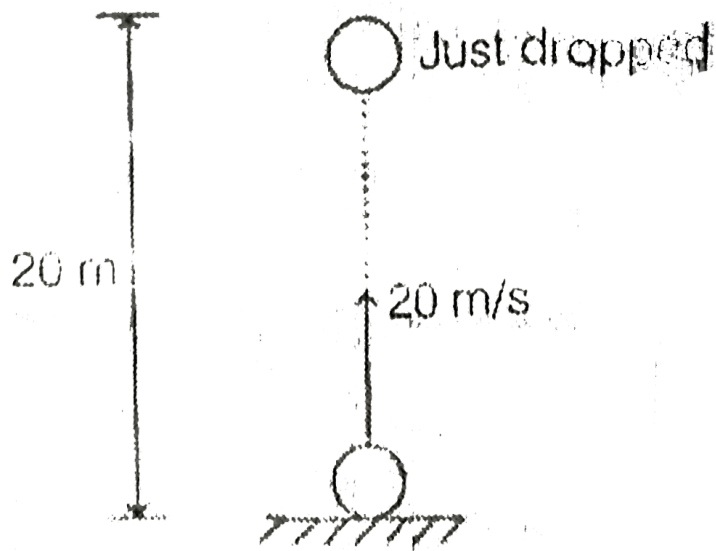

A.  $(1 + \sqrt{2})s$

B.  $2\sqrt{2}s$

C.  $(2 + \sqrt{2})s$

D. None of the above



Watch Video Solution

8. Two identical masses are as shown in figure. One is thrown upwards with velocity 20 m/s and another is just dropped simultaneously.

In the above problem, to what maximum height (from ground) with the combined mass rise ?

A. 25 m

B. 18 m

C. 15 m

D. 20 m



[Watch Video Solution](#)

9. Two identical masses are as shown in figure. One is thrown upwards with velocity 20 m/s and another is just dropped simultaneously.

If the collision between them is elastic, find the time interval between their striking with ground 

A. Zero

B. 2 s

C. 1 s

D. 3 s



Watch Video Solution

#### 10. Comprehension # 4

When the mass of a system is variable, a thrust force has to be applied on it in addition to all other forces acting on it. This thrust force is given by :

$\vec{F} = \vec{v}_r \left( \pm \frac{dm}{dt} \right)$ . Here  $\vec{v}_r$  is the relative velocity with which the mass

$dm$  either enters or leaves the system.

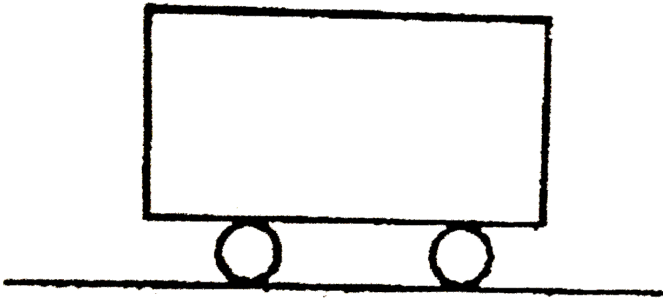

A car has total mass  $50\text{kg}$ . Gases are ejected from its backwards with relative velocity  $20\text{m/s}$ . The rate of ejection of gas is  $2\text{kg/s}$ . Total mass of gas is  $20\text{kg}$ . Coefficient of friction between the car and road is  $\mu = 0.1$ . Car will start moving after time  $t = \dots\dots\dots\text{s}$ .

- A. 4
- B. 10
- C. 5
- D. 8

 [Watch Video Solution](#)

## 11. Comprehension # 4

When the mass of a system is variable, a thrust force has to be applied on it in addition to all other forces acting on it. This thrust force is given by :

$\vec{F} = \vec{v}_r \left( \pm \frac{dm}{dt} \right)$ . Here  $\vec{v}_r$  is the relative velocity with which the mass  $dm$  either enters or leaves the system.

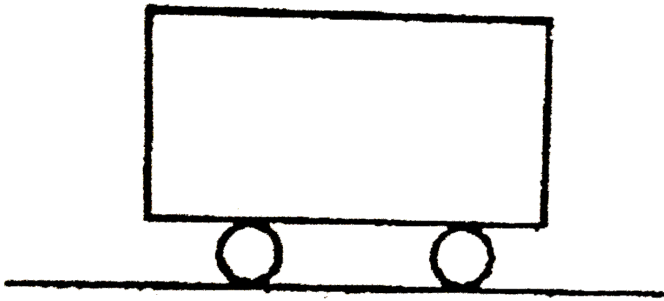

A car has total mass  $50kg$ . Gases are ejected from its backwards with relative velocity  $20m/s$ . The rate of ejection of gas is  $2kg/s$ . Total mass of gas is  $20kg$ . Coefficient of friction between the car and road is  $\mu = 0.1$ .

Maximum speed of car will be  $v = \dots\dots m/s$  :- (Take  $\ln\left(\frac{4}{3}\right) = 0.28$ )

A. 0.6

B. 0.8

C. 1.0

 [Watch Video Solution](#)

## 12. Comprehension # 4

When the mass of a system is variable, a thrust force has to be applied on it in addition to all other forces acting on it. This thrust force is given by :

$\vec{F} = \vec{v}_r \left( \pm \frac{dm}{dt} \right)$ . Here  $\vec{v}_r$  is the relative velocity with which the mass

$dm$  either enters or leaves the system.

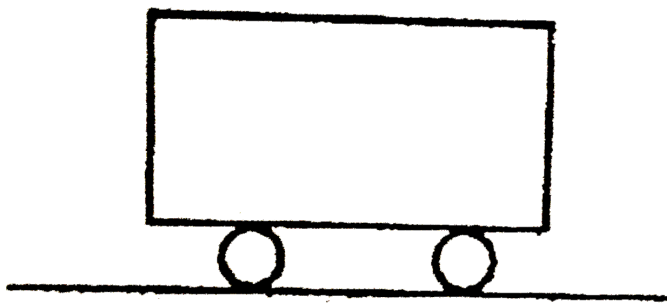

A car has total mass  $50kg$ . Gases are ejected from its backwards with relative velocity  $20m/s$ . The rate of ejection of gas is  $2kg/s$ . Total mass

of gas is  $20\text{kg}$ . Coefficient of friction between the car and road is  $\mu = 0.1$ .

Car will stop after (from starting)  $t = \dots\dots\dots \text{ s}$ .

A. 12.2

B. 6.4

C. 10.6

D. 5.8



[Watch Video Solution](#)

**13.** Acceleration of two identical particles moving in a straight line are as shown in figure.

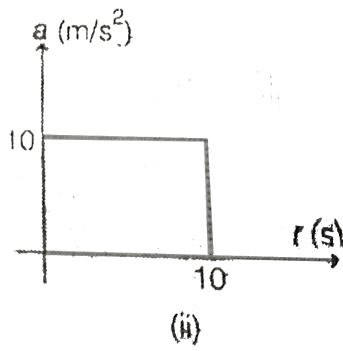
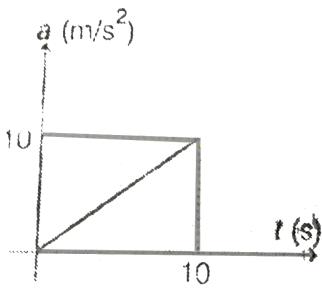

The corresponding  $a$ - $t$  graph of their centre of mass will be

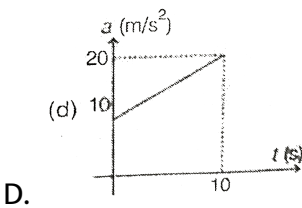
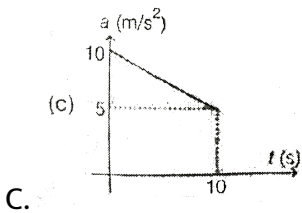
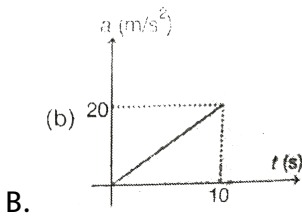
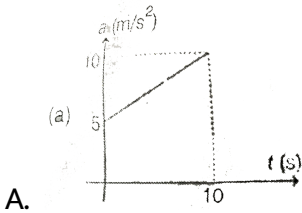





Watch Video Solution

14. Acceleration of two identical particles moving in a straight line are as shown in figure.

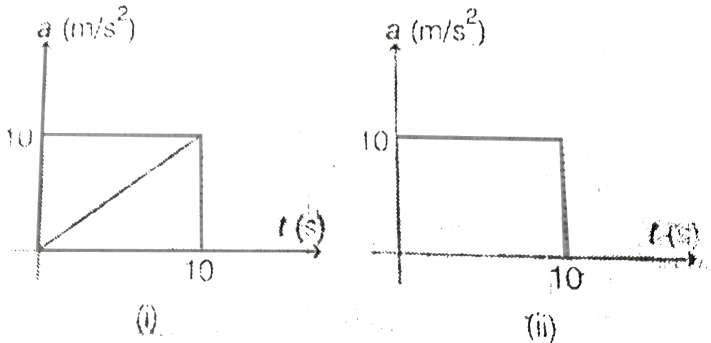

If initial velocity of both the particles was zero. Then velocity of their centre of mass after  $10$  s will be

- A.  $40$   $\text{m/s}$
- B.  $60$   $\text{m/s}$
- C.  $75$   $\text{m/s}$
- D.  $120$   $\text{m/s}$



Watch Video Solution

### 15. Comprehension # 5

One particle of mass  $1kg$  is moving along positive  $x$ -axis with velocity  $3m/s$ . Another particle of mass  $2kg$  is moving along  $y$ -axis with  $6m/s$ . At time  $t = 0$ ,  $1kg$  mass is at  $(3m, 0)$  and  $2kg$  at  $(0, 9m)$ ,  $x - y$  plane is the horizontal plane. (Surface is smooth for question 1 and rough for question 2 and 3)

The centre of mass of the two particles is moving in a straight line for which equation is :

- A.  $y=x+2$
- B.  $y=4x+2$
- C.  $y=2x-4$
- D.  $y=2x+4$



Watch Video Solution

1. A long block A is at rest on a smooth horizontal surface. A small block B, whose mass is half of A, is placed on A at one end and projected along A with some velocity  $u$ . The coefficient of friction between the blocks is  $\mu$ :

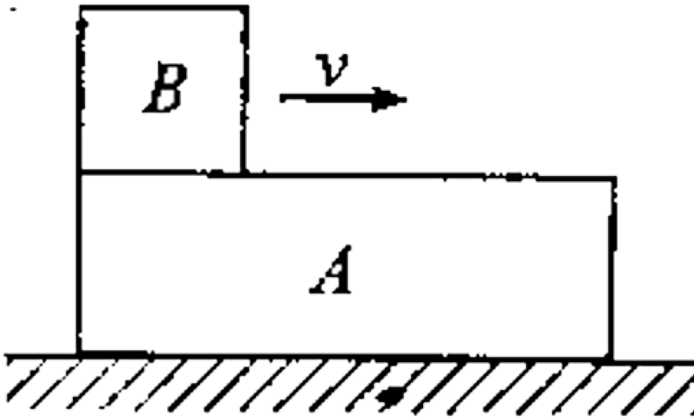

- A. the blocks will reach a final common velocity  $\mu/3$
- B. the work done against friction is two-third of the initial kinetic energy of B
- C. before the blocks reach a common velocity the acceleration of A relative to B is  $(2/3) \mu g$

D. before the blocks reach a common velocity, the acceleration of A

relative to B is  $(3/2)\mu g$

 [Watch Video Solution](#)

2. In a one dimensional collision between two identical particles A and B, B is stationary and A has momentum  $p$  before impact. During impact, B gives impulse  $J$  to A.

A. the total momentum of A plus B system is before and after the impact and  $(p-J)$  during the impact

B. during the impact B gives impulse  $J$  to A

C. the coefficient of restitution is  $(2J/p) - 1$

D. the coefficient of restitution is  $(2J/p) + 1$

 [Watch Video Solution](#)

3. Ball A of mass  $m$  strikes a stationary ball B of mass  $M$  and undergoes an elastic collision. After collision ball A has a speed one third of its initial speed. The ratio of  $M/m$  is

A.  $\frac{1}{4}$

B.  $\frac{1}{2}$

C. 2

D. 4



[Watch Video Solution](#)

4. Two small balls A and B of mass  $M$  and  $3M$  hang from the ceiling by strings of equal length. The ball A is drawn aside, so that it is raised to a

height  $H$ . It is then released and collides with ball B. Select the correct

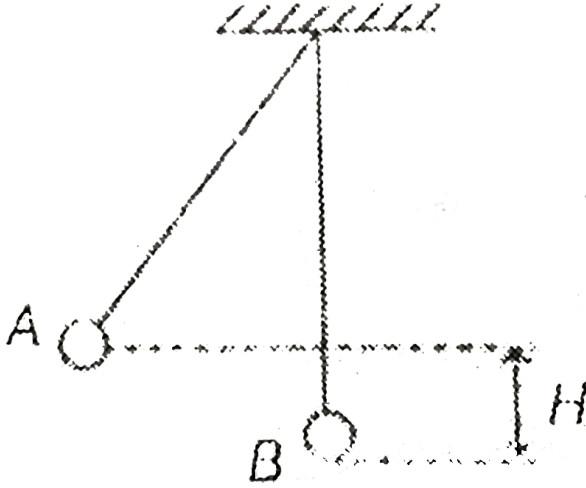

answer (s)

- A. If collision is elastic, ball B will rise to a height  $H/4$
- B. If the collision is elastic ball A will rise up to a height  $H/4$
- C. If the collision is perfectly inelastic, the combined mass will rise to a height  $H/16$
- D. If the collision is perfectly inelastic, the combined mass will rise to a height  $H/4$

Answer: A,D



Watch Video Solution

5. Two particles of same mass and charge are thrown in same direction along the horizontal with same velocity  $v$  from two different heights  $h_1$  and  $h_2$  ( $h_1 < h_2$ ). Initially they were located in the same vertical line. Select the correct alternative (s).

A. Both the particles always lie on a vertical line

B. Acceleration of the centre of mass of the two particles is  $g$  downwards

C. Horizontal displacement on reaching to ground of particle lying at  $h_1$  is less than the value, which would have been in the absence of charges on them

D. Horizontal displacement on reaching to ground of particle lying at  $h_2$  is more than the value, which would have been in the absence of charges on them



6. A ball A collides elastically with another identical ball B with velocity  $10 \text{ m/s}$  at an angle of  $30^\circ$  from the line joining their centres  $C_1$  and  $C_2$ . Select the correct alternative (s).

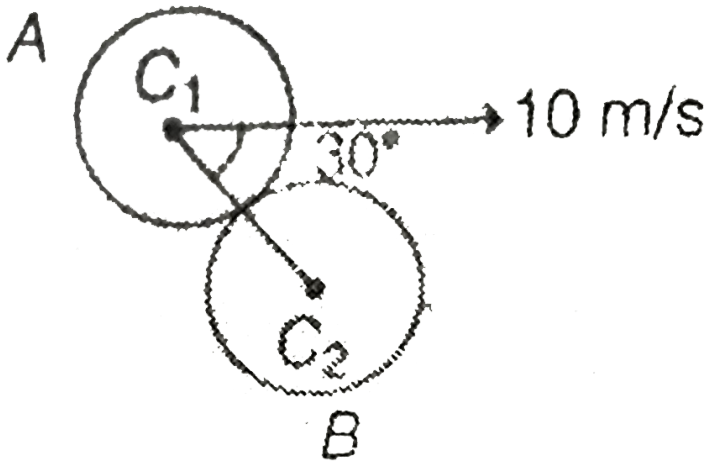

- A. Velocity of ball A after collision is  $5 \text{ m/s}$
- B. Velocity of ball B after collision is  $5\sqrt{3} \text{ m/s}$
- C. Both the balls move at right angles after collision
- D. Kinetic energy will not be conserved here, because collision is not head on



Answer: B,C,D



Watch Video Solution

7. A projectile is fixed on a horizontal ground. Coefficient of restitution between the projectile and the ground is 'e'. If  $a$ ,  $b$  and  $c$  be the ration of time of flight  $\left[ \frac{T_1}{T_2} \right]$ , maximum height  $\left[ \frac{H_1}{H_2} \right]$  and horizontal range  $\left[ \frac{R_1}{R_2} \right]$  in first two collisions with the ground, then

A.  $a = \frac{1}{e}$

B.  $b = \frac{1}{2e}$

C.  $c = \frac{1}{2e}$

D. All of these



Watch Video Solution

8. A man of mass  $m$  is standing on a stationary flat car of mass  $M$ . The car can move without friction along horizontal rails. The man starts walking with velocity  $v$  relative to the car. Work done by him

A. is less than  $\frac{1}{2}mv^2$ , if he walks along the rails

B. is equal to  $\frac{1}{2}mv^2$ , if he walks normal to the rails

C. can never be less than  $\frac{1}{2}mv^2$ ,

D. is greater than  $\frac{1}{2}mv^2$ , if he walks along the rails



[Watch Video Solution](#)

9. A particle moving with kinetic energy  $E$  makes a head on elastic collision with an identical particle at rest. During the collision

A. elastic potential energy of the system is always zero

B. maximum elastic potential energy of the system is  $E/2$

C. minimum kinetic energy of the system is  $E/2$

D. kinetic energy of the system is constant

**Answer: B,C**

 [Watch Video Solution](#)

10. A body is fired from point P and strikes at Q inside a smooth circular wall as shown in the figure. It rebounds to point S (diametrically opposite to P), then

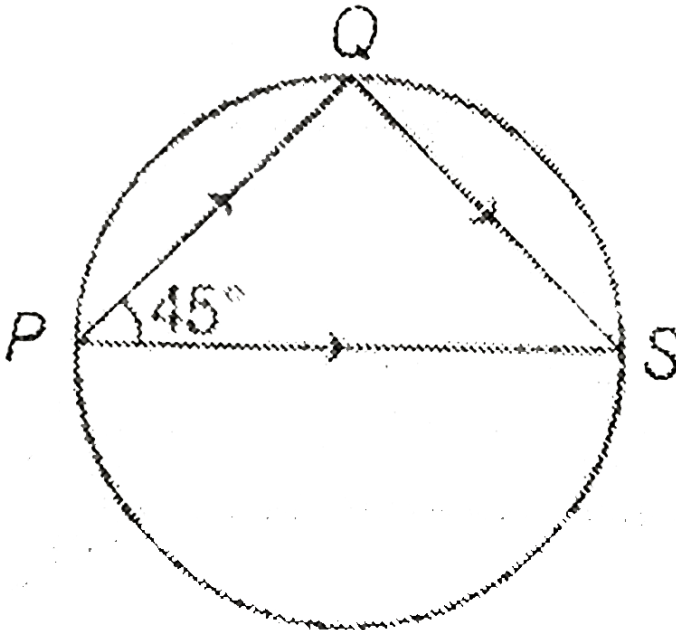

- A. the coefficient of restitution is  $\frac{1}{2}$
- B. the coefficient of restitution is 1
- C. kinetic energy is conserved in this collision
- D. kinetic energy is not conserved in this collision

**Answer: B,D**

 [Watch Video Solution](#)

11. A ball B of mass  $m$  is lying at rest on the top surface of a smooth horizontal table 5 m high. Another moving ball A of same mass makes an elastic collision with B slides off the table and strikes the floor at a horizontal distance of 10 m from the table. Then select the correct alternatives (s). [ $g = 10 \text{ m/s}^2$ ]

- A. The velocity of the ball A before collision is 5 m/s
- B. The kinetic energy of the ball B at the time when it strikes the ground is  $(m \times 100) \text{ J}$

C. the velocity of the ball A before collision is 10 m/s

D. The kinetic energy of the ball B at the time when it strikes the ground is  $(50xm) \text{ J}$

Answer: C,D

[Watch Video Solution](#)

12. A ball strikes the ground at an angle  $\alpha$ . and rebound at an angle  $\beta$ . with the vertical as shown in the figure .Then ,

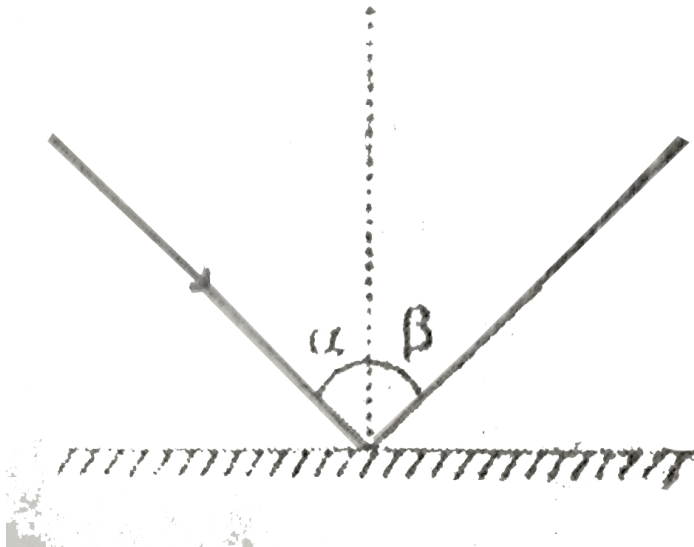

A. coefficient of restitution is  $\frac{\tan \alpha}{\tan \beta}$

B.  $\alpha < \beta$  the collision is inelastic

C. if  $\alpha < \beta$  the collision is elastic

D. if  $\alpha > \beta$  the collision is inelastic

 [Watch Video Solution](#)

13. A block of mass  $m$  moving with a velocity  $v_0$  collides with a stationary block of mass  $M$  to which a spring of stiffness  $k$  is attached, as shown in Fig. Choose the correct alternative(s)

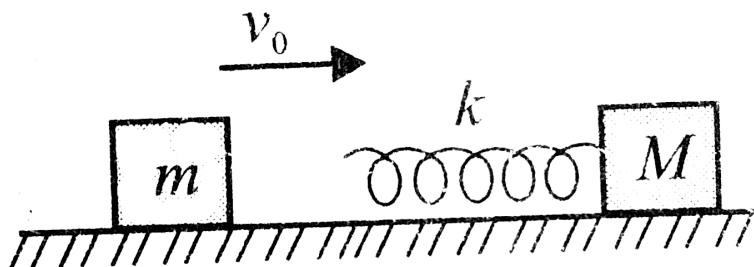

A. The velocity of centre of mass is  $\frac{m}{m+M}v_0$

B. The initial kinetic energy of the system in the centre of mass frame

$$\text{is } \frac{1}{4} \left( \frac{mM}{M+m} \right) v_0^2$$

C. The maximum compression in the spring is  $\sqrt{\frac{nMl}{(m+M)k}}$

D. When the spring is in the state of maximum compression the kinetic energy in the centre of mass frame is zero



[Watch Video Solution](#)

14. In which of the following cases the centre of mass of a rod is certainly not at its centre?

A. the density continuously increase from left to right

B. the density continuously decreases from left to right

C. the density decreases from left to right upto the center and then increases

D. the density increases from left to right upto the centre and then decreases

 [Watch Video Solution](#)

15. A nonzero external force acts on a system of particles. The velocity and the acceleration of the centre of mass are found to be  $v_0$  and  $a_0$  at an instant  $t$ . It is possible that:

A.  $v_0 = 0, a_0 = 0$

B.  $v_0 = 0, a_0 \neq 0$

C.  $v_0 \neq 0, a_0 = 0$

D.  $v_0 \neq 0, a_0 \neq 0$

 [Watch Video Solution](#)



16. Two particles A and B of equal size but of masses  $mkg$  and  $2mkg$  are moving directly towards each other with speeds  $21m/s$  and  $4m/s$  respectively. After collision, A moves with a speed of  $1m/s$  in the original direction. Then:

- A. The velocity of B after collision is  $5\text{ m/s}$  opposite its direction of motion before collision.
- B. The coefficient of restitution is  $0.2$
- C. The loss of kinetic energy due to collision is  $200\text{ J}$
- D. The impulse of the force between the two balls is  $40\text{ N-s}$



[Watch Video Solution](#)

17. Two identical particles A and B of mass  $m$  each are connected together by a light and inextensible string of length  $l$ . The particles are held at rest in air in same horizontal level at a separation  $l$ . Both particles are

released simultaneously and one of them (say A) is given speed  $V_0$  vertically upward. Choose the correct options (s). Ignore air resistance.

A. The maximum height attained by the center of mass of the system

of A and B is  $\frac{v_0^2}{8g}$

B. The kinetic energy of the system of A and B when the centre of

mass is at its highest point is  $\frac{mv_0^2}{2}$

C. The maximum height attained by the centre of mass of the system

of A and B is  $\frac{v_0^2}{4g}$

D. The kinetic energy of the system of A and B when the centre of

mass is at its highest point is  $\frac{mv_0^2}{4}$



[Watch Video Solution](#)

**18.** A smooth sphere A of mass  $m$  collides elastically with an identical sphere B at rest. The velocity of A before collision is  $8m/s$  in a direction

making  $60^\circ$  with the line of centres at the time of impact, Then

- A. The spher A comes to rest after collision
- B. The sphere B will move with a speed of 8 m/s after collision
- C. The directions of motion of A and Bafter collision are at tight angles
- D. The speed of B after collision is 4 m/s



[Watch Video Solution](#)

### 19. Comprehension # 5

One particle of mass  $1kg$  is moving along positive  $x$ -axis with velocity  $3m/s$ . Another particle of mass  $2kg$  is moving along  $y$ -axis with  $6m/s$ . At time  $t = 0$ ,  $1kg$  mass is at  $(3m, 0)$  and  $2kg$  at  $(0, 9m)$ ,  $x - y$  plane is the horizontal plane. (Surface is smooth for question 1 and rough for question 2 and 3)

If both the particles have the same value of coefficient of friction  $\mu = 0.2$ .

The centre of mass will stop at time  $t = \dots\dots\dots$ s :-

A. 1.5

B. 4.5

C. 3.0

D. 2.0



Watch Video Solution

## 20. Comprehension # 5

One particle of mass  $1kg$  is moving along positive x-axis with velocity  $3m/s$ . Another particle of mass  $2kg$  is moving along y-axis with  $6m/s$ . At time  $t = 0$ ,  $1kg$  mass is at  $(3m, 0)$  and  $2kg$  at  $(0, 9m)$ ,  $x - y$  plane is the horizontal plane. (Surface is smooth for question 1 and rough for question 2 and 3)

Co-ordinates of centre of mass where it will stop finally are :-

A. (2.0 m,14.25 m)

B. (2.25 m,10 m)

C. (3.75 m,9 m)

D. (1.75 m,12 m)

 [Watch Video Solution](#)

21. A block of mass 1 kg is moving towards a movable wedge of mass 2 kg as shown in figure. All surfaces are smooth. When the block leaves the wedge from top, its velocity is making an angle  $\theta = 30^\circ$  with horizontal.

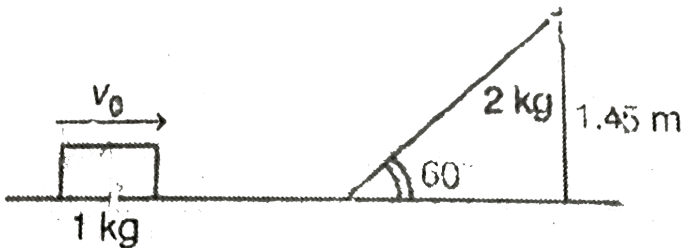

The value of  $v_0$  in m/s is

A. 4

B. 7

C. 10

D. 9



Watch Video Solution

22. A block of mass 1 kg is moving towards a movable wedge of mass 2 kg as shown in figure. All surfaces are smooth. When the block leaves the wedge from top, its velocity is making an angle  $\theta = 30^\circ$  with horizontal.

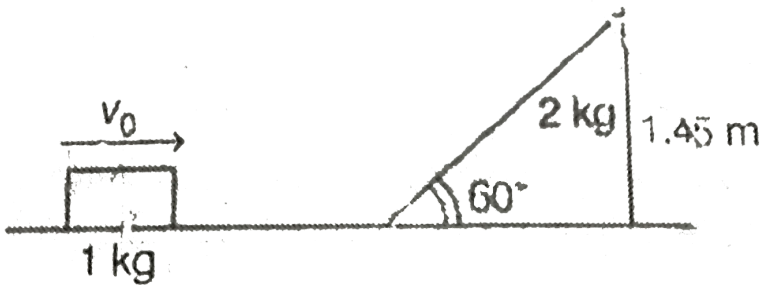

To what maximum height will the block rise

A. 1.9 m

B. 2.7 m

C. 1.6 m

D. 1.45 m

 Watch Video Solution

23. A block of mass 1 kg is moving towards a movable wedge of mass 2 kg as shown in figure. All surfaces are smooth. When the block leaves the wedge from top, its velocity is making an angle  $\theta = 30^\circ$  with horizontal.

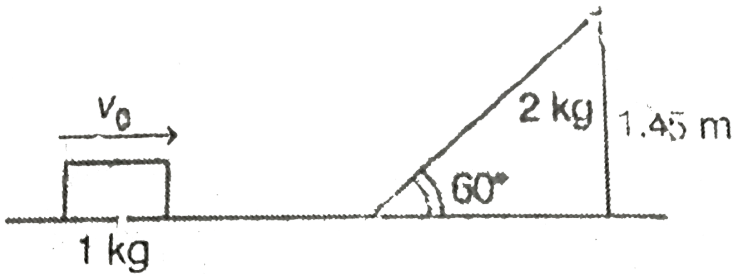

In the whole process let  $J$  be the magnitude of net impulse given to the block by the wedge,  $J_H$  its horizontal component and  $J_V$  its vertical component. Then

A.  $J = \frac{8}{\sqrt{3}} \text{ N}\cdot\text{s}$

B.  $J_H = 4N - s$

C.  $J_V = \frac{4}{\sqrt{3}} \text{ N-s}$

D. All of the above

 [Watch Video Solution](#)

24. Two blocks (from very far apart) are approaching towards each other with velocities as shown in figure. The coefficient of friction for the blocks is  $\mu = 0.2$ .

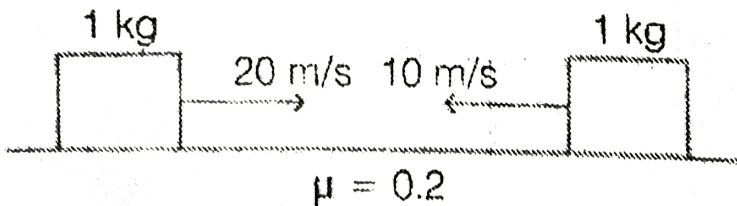

Linear momentum of the system is

A. conserved all the time

B. never conserved

C. is conserved only upto 5 s



D. None of the above

 Watch Video Solution

25. Two blocks (from very far apart) are approaching towards each other with velocities as shown in figure. The coefficient of friction for the blocks is  $\mu = 0.2$ .

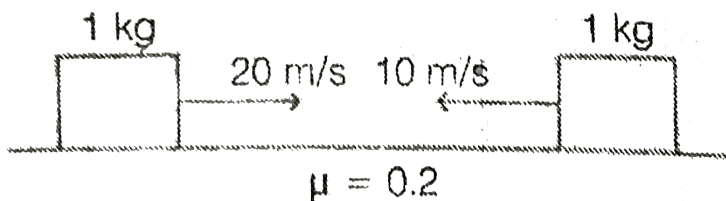

How much distance will centre of mass travel before coming permanently to rest.

A. 25 m

B. 37.5 m

C. 42.5 m

D. 50 m



Watch Video Solution

## 26. Comprehension # 6

A  $1\text{kg}$  block is given a velocity of  $15\text{m/s}$  towards right over a very long rough plank of mass  $2\text{kg}$  as shown in figure.

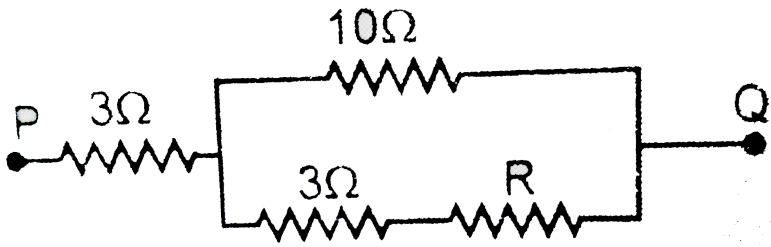

The correct graph showing linear momentum of  $1\text{kg}$  (i.e.  $p_1$ ) and of  $2\text{kg}$  (i.e.  $p_2$ ) versus time is :

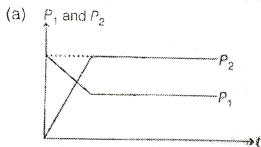

A.

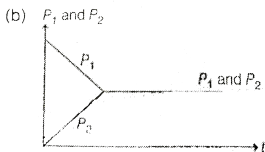

B.

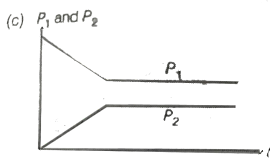

C.

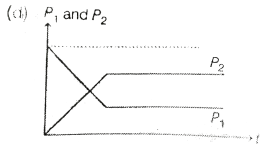

D.

 [Watch Video Solution](#)

## 27. Comprehension # 6

A  $1\text{kg}$  block is given a velocity of  $15\text{m/s}$  towards right over a very long rough plank of mass  $2\text{kg}$  as shown in figure.

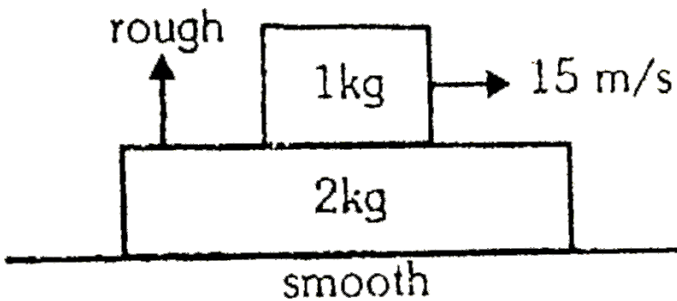

If coefficient of friction between the two blocks is equal to  $0.4$ , then

magnitude of initial slope of  $p_1$  versus  $t$  and  $p_2$  versus  $t$  (in SI unit) will be

:-

A. 4 and 2

B. 2 and 4

C. 4 and 4

D. 2 and 2



Watch Video Solution

### 28. Comprehension # 6

A  $1\text{kg}$  block is given a velocity of  $15\text{m/s}$  towards right over a very long rough plank of mass  $2\text{kg}$  as shown in figure.

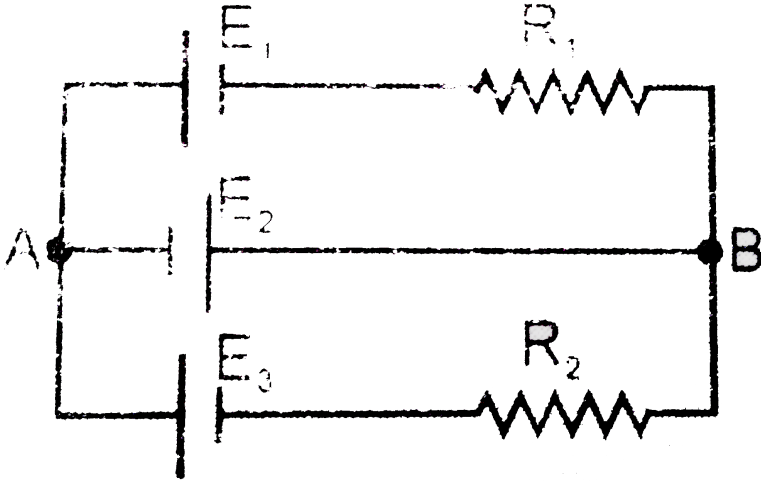

Momentum of both the blocks are equal at time  $t = \dots\dots s$  :

- A. 1.75
- B. 1.875
- C. 2.5
- D. 1.25

[▶ Watch Video Solution](#)

29. A ball of mass 3 kg is thrown upwards with velocity 20 m/s. After 1 s it explodes in 2 pieces one of mass 1 kg and other of 2 kg. After explosion

both the pices maintain their vertical velocities but on ground they fall 90 m apart.

Speed of both the pieces just after explosion are (both in m/s)

A.  $10\sqrt{5}$ ,  $10\sqrt{2}$

B. 30, 20

C.  $20\sqrt{3}$ ,  $10\sqrt{3}$

D.  $20\sqrt{2}$ , 20



[Watch Video Solution](#)

**30.** A ball of mass 3 kg is thrown upwards with velocity 20 m/s. After 1 s it explodes in 2 pieces one of mass 1 kg and other or 2 kg. After explosion both the pices maintain their vertical velocities but on ground they fall 90 m apart

Energy produced (in joule) during explosion is

A. 150

B. 200

C. 300

D. 450



Watch Video Solution

31. Two blocks of equal mass  $m$  are connected by an unstretched spring and the system is kept at rest on a frictionless horizontal surface. A constant force  $F$  is applied on the first block pulling away from the other as shown in Fig.

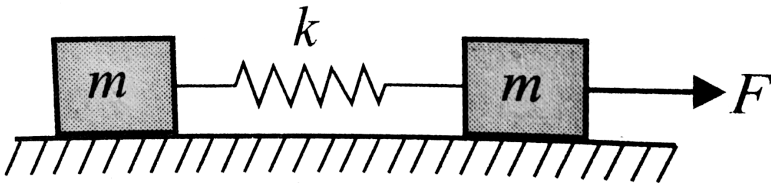

Then the displacement of the centre of mass in at time  $t$  is

A.  $\frac{Ft^2}{2m}$

B.  $\frac{Ft^2}{3m}$

C.  $\frac{Ft^2}{4m}$

D.  $\frac{Ft^2}{m}$

 [Watch Video Solution](#)

32. Two blocks of equal mass  $m$  are connected by an unstretched spring and the system is kept at rest on a frictionless horizontal surface. A constant force  $F$  is applied on the first block pulling away from the other as shown in Fig.

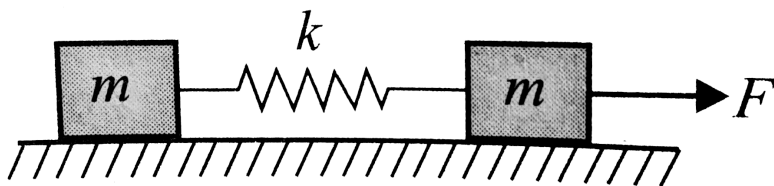

If the extension of the spring is  $x_0$  at time  $t$ , then the displacement of the first block at this instant is



A.  $\frac{1}{2} \left( \frac{Ft^2}{2m} + x_0 \right)$

B.  $\left( \frac{Ft^2}{2m} - x_0 \right)$

C.  $\frac{1}{2} \left( \frac{Ft^2}{2m} - x_0 \right)$

D.  $\left( \frac{Ft^2}{2m} + x_0 \right)$

 [Watch Video Solution](#)

**33.** Two blocks of equal mass  $m$  are connected by an unstretched spring and the system is kept at rest on a frictionless horizontal surface. A constant force  $F$  is applied on the first block pulling away from the other as shown in Fig.

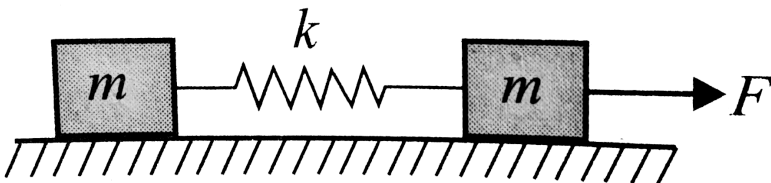

If the extension of the spring is  $x_0$  at time  $t$ , then the displacement of the first block at this instant is

A.  $\left(\frac{Ft^2}{2m} - \times_0\right)$

B.  $\frac{1}{2}\left(\frac{Ft^2}{2m} + \times_0\right)$

C.  $\frac{1}{2}\left(\frac{2Ft^2}{m} - \times_0\right)$

D.  $\frac{1}{2}\left(\frac{Ft^2}{2m} - \times_0\right)$

[Watch Video Solution](#)

34. Two balls marked 1 and 2 of the same mass  $m$  and a third ball marked 3 of mass  $M$  are arranged over a smooth horizontal surface as shown in the figure. Ball 1 moves with a velocity  $v_1$  towards ball 2. All collisions are assumed to be elastic. If  $M < m$ , the number of collisions between the balls will be.



A. one

B. two

C. three

D. four

 Watch Video Solution

35. Two balls marked 1 and 2 of the same mass  $m$  and a third ball marked 3 of mass  $M$  are arranged over a smooth horizontal surface as shown in the figure. Ball 1 moves with a velocity  $v_1$  towards ball 2. All collisions are assumed to be elastic. If  $M < m$ , the number of collisions between the balls will be.



A. one

B. two

C. three

D. four



Watch Video Solution

36. A system consists of block A and B each of mass  $m$  connected by a light spring as shown in the figure with block B in contact with a wall. The block A compresses the spring by  $3mg/k$  from natural length of spring and then released from rest. Neglect friction anywhere

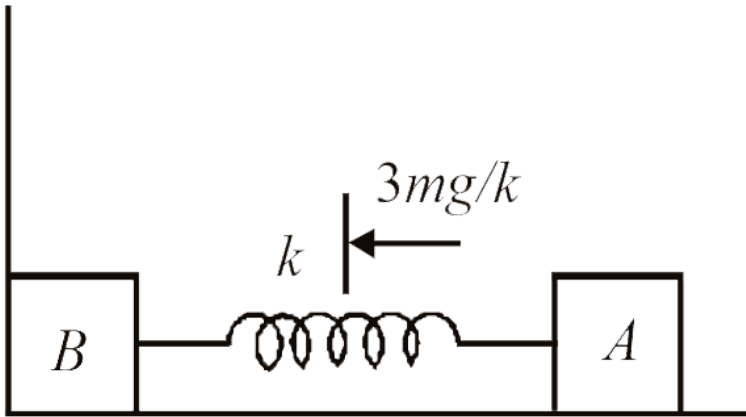

Acceleration of centre of mass of system comprising A and B just after A is released is

A. 0

B.  $\frac{3g}{2}$

C.  $3g$

D.  $g/2$

 Watch Video Solution

37. A system consists of block A and B each of mass  $m$  connected by a light spring as shown in the figure with block B in contact with a wall. The block A compresses the spring by  $3mg/k$  from natural length of spring and then released from rest. Neglect friction anywhere.

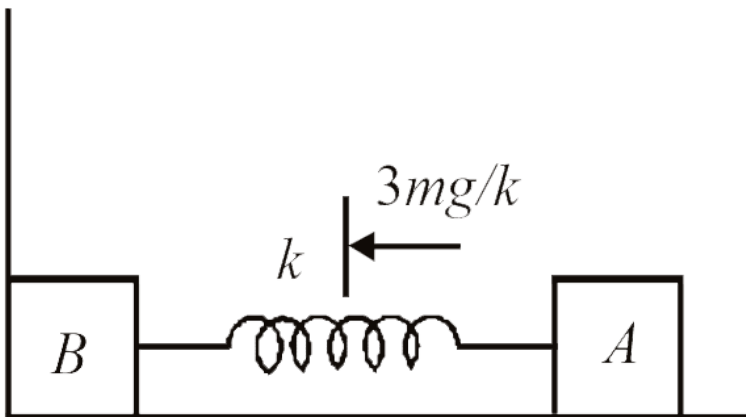

Velocity of centre of mass of system comprising A and B when block B just loses contact with the wall

- A.  $\sqrt{\frac{m}{K}}$
- B.  $\frac{3g}{2} \sqrt{\frac{m}{k}}$
- C.  $2g \sqrt{\frac{m}{k}}$

D. None of these

[▶ Watch Video Solution](#)

38. In the arrangement shown in figure match the following:

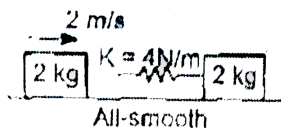

Column-1	Column-2
(A) Velocity of centre of mass	(P) 2 SI unit
(B) Velocity of combined mass when compression in the spring is maximum	(Q) 1 SI unit
(C) Maximum compression in the spring	(R) 4 SI unit
(D) Maximum potential energy stored in the spring	(S) 0.5 SI unit

[▶ Watch Video Solution](#)

39. A particle of mass  $m$ , kinetic energy  $K$  and momentum  $p$  collides head on elastically with another particle of mass  $2m$  at rest. After collision, :

Column I

Column II

- |                                       |                    |
|---------------------------------------|--------------------|
| (A) Momentum of first particle        | (p) $3/4p$         |
| (B) Momentum of second particle       | (q) $-K/9$         |
| (C) Kinetic energy of first particle  | (r) $-p/3$         |
| (D) Kinetic energy of second particle | (s) $\frac{8K}{9}$ |
|                                       | (t) None           |



Watch Video Solution

40. Match the following: (P = momentum of particle, K = kinetic energy of particle)

Column-1	Column-2
(A) $P$ is increased by 200%, corresponding change in $K$	(P) 800%
(B) $K$ is increased by 300%, corresponding change in $P$	(Q) 200%
(C) $P$ is increased by 1%, corresponding change in $K$	(R) 0.5%
(D) $K$ is increased by 1%, corresponding change in $P$	(S) 2%
	(T) None

 [Watch Video Solution](#)

41. Four points are placed at four corners of a square of side 4 m as shown. Match the following table.

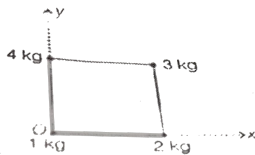

Table-1	Table-2
(A) $x$ -co-ordinate of centre of mass of 4 kg and 2 kg	(P) $(7/2)m$
(B) $x$ -co-ordinate of centre of mass of 4 kg, 2 kg and 3 kg	(Q) $4/3 m$
(C) $y$ -co-ordinate of centre of mass of 1 kg, 4 kg and 3 kg	(R) 3 m
(D) $y$ -co-ordinate of centre of mass of 1 kg and 3 kg	(S) $(20/9) m$



42. Two balls of mass  $m$  and  $2m$  each have momentum  $2p$  and  $p$  in the direction shown in figure. During collision they exert an impulse of magnitude  $p$  on each other.



Column I

- (A) After collision momentum of  $m$   
(B) After collision momentum of  $2m$   
(C) Coefficient of restitution between them

Column II

- (p)  $2p$   
(q)  $p$   
(r) 1  
(s) None