

PHYSICS

BOOKS - DC PANDEY PHYSICS (HINGLISH)

GENERAL PHYSICS

Scq Type

1. Which of the following sets cannot enter into the list of fundamental quantities in any system of units ?

- A. length, mass and velocity
- B. length, time and velocity
- C. mass, time and velocity

D. length, time and mass

Answer: B



Watch Video Solution

2. Force F is given in terms of time t and distance x by $F = A \sin Ct + B \cos Dx$. Then the dimensions of A/B and C/D are

A. $[MLT^{-3}, M^0L^0T^{-1}]$

B. $[MLT^{-2}, M^0L^{-1}T^0]$

C. $[M^0L^0T^0, M^0LT^{-1}]$

D. $[M^0LT^{-1}, M^0L^0L^0T^0]$

Answer: C



Watch Video Solution

3. Dimensions of electrical resistance are

A. $[ML^2T^{-2}I^2]$

B. $[ML^2T^{-3}I^{-2}]$

C. $[ML^2T^{-3}I^2]$

D. $[ML^2T^{-2}I^{-2}]$

Answer: B



Watch Video Solution

4. The velocity of water wave v may depend on their wavelength λ , the density of water ρ and the acceleration due to gravity g .

The method of dimensions gives the relation between these quantities as

A. $v^2 = k\lambda^{-1}g^{-1}\rho^{-1}$

B. $v^2 = kg\lambda$

C. $v^2 = kg\lambda\rho$

D. $v^2 = k\lambda^3g^{-1}\rho^{-1}$

Answer: B



Watch Video Solution

5. If unit of length and time is double, the numerical value of 'g' (acceleration due to gravity) will be

A. doubled

B. halved

C. four times

D. remain same

Answer: A



Watch Video Solution

6. From some instruments current measured is $I = 10.0\text{amp}$, potential different measured is $V = 100.0\text{V}$, length of wire is 31.4cm , and diameter of wire is 2.00mm (all in correct significant figure). The resistivity of wire (in correct significant figures) will be (use $\pi = 3.14$)

A. $1.00 \times 10^{-4}\Omega - m$

B. $1.0 \times 10^{-4}\Omega - m$

C. $1 \times 10^{-4}\Omega - m$

D. $1.000 \times 10^{-4} \Omega - m$

Answer: A



Watch Video Solution

7. In a meter bridge, null point is at $l = 33.7\text{cm}$, when the resistance S is shunted by 12Ω resistance the null point is found to be shifted by a distance of 18.2cm . The value of unknown

resistance R should be

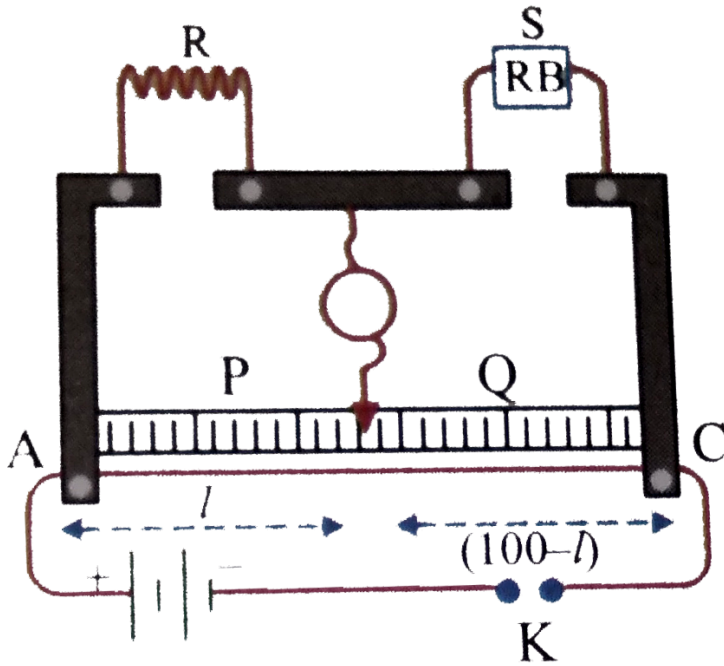

- A. 13.5Ω
- B. 68.8Ω
- C. 3.42Ω
- D. None of these

Answer: B



Watch Video Solution

8. The external and internal diameters of a hollow cylinder are measured to be (4.23 ± 0.01) cm and (3.89 ± 0.01) cm. The thickne of the wall of the cylinder is

A. (0.34 ± 0.02) cm

B. (0.17 ± 0.02) cm

C. (0.17 ± 0.01) cm

D. (0.34 ± 0.01) cm

Answer: C



Watch Video Solution

9. In a vernier callipers, N divisions of the main scale coincide with $N + m$ divisions of the vernier scale. what is the value of m for which the instrument has minimum least count.

A. 1

B. N

C. $\frac{N}{10}$

D. $N/2$

Answer: A



[Watch Video Solution](#)

10. In a meter bridge set up, which of the following should be the properties of the one meter long wire?

- A. High resistivity and low temperature coefficient
- B. Low resistivity and low temperature coefficient
- C. Low resistivity and high temperature coefficient
- D. High resistivity and high temperature coefficient

Answer: A



Watch Video Solution

11. The dimension of the ratio of magnetic flux and the resistance is equal to that of:

- A. emf
- B. charge
- C. inductance
- D. current

Answer: B



Watch Video Solution

12. 1cm on the main scale of a vernier callipers is divided into 10 *equal* parts. If 10 divisions of vernier coincide with 8 small divisions of main scale, then the least count of the calliper is.

A. 0.01cm

B. 0.02cm

C. 0.05cm

D. 0.005cm

Answer: B



Watch Video Solution

13. The vernier constant of a vernier callipers is 0.001cm . If 49 main scale divisions coincide with 50 vernier scale divisions, then the value of 1 main scale divisions is .

A. 0.1m

B. 0.5m

C. 0.4m

D. 1mm

Answer: B



[Watch Video Solution](#)

14. 1cm of main scale of a vernier callipers is divided into 10 divisions. The least count of the callipers is 0.005cm , then the vernier scale must have.

A. 10 divisions

B. 20 divisions

C. 25 divisions

D. 50 divisions

Answer: B



Watch Video Solution

15. Vernier constant is the

A. value of one MSD divided by total number of divisions on
the main scale

B. value of one VSD divided by total number of divisions on
the vernier scale

C. total number of divisions on the main scale divided by
total number of divisions on the vernier scale

D. difference between value of one main scale division and
one vernier scale division

Answer: D

 [Watch Video Solution](#)

16. The graph between $\frac{1}{v}$ and $\frac{1}{u}$ for a concave mirror looks like.

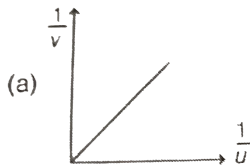

A.

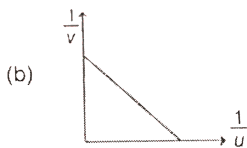

B.

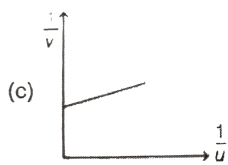

C.

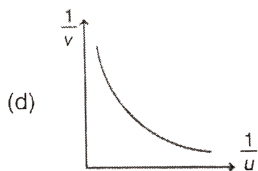

D.

Answer: B

 **Watch Video Solution**

17. The graph showing correctly the variation of image distance (v) as a function of object distance (u) in case of a concave mirror is

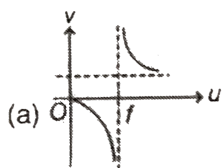

A.

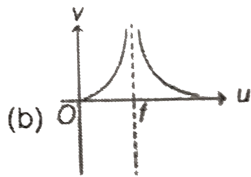

B.

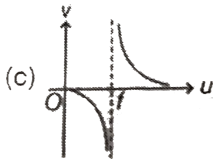

C.

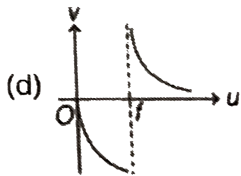

D.

Answer: A



Watch Video Solution

18. The ratio of the dimensions of plank's constant and that of the moment of inertia is the dimension of

A. frequency

B. velocity

C. angular momentum

D. time

Answer: A



Watch Video Solution

19. The dimensions of the quantity L/C is identical to

A. (resistance)⁻¹

B. (time)⁻²

C. (resistance)²

D. None of these

Answer: C

 [Watch Video Solution](#)

20. The dimensions of h/e ($h =$ Plank's constant and $e =$ electronic charge) are same as that of

- A. magnetic field
- B. electric flux
- C. electric field
- D. magnetic field

Answer: A

 [Watch Video Solution](#)

21. The dimensions of (angular momentum)/(magnetic moment) are

A. $[M^3LT^{-2}A^2]$

B. $[MA^{-1}T^{-1}]$

C. $[ML^2A^{-2}T]$

D. $[M^2L^{-3}AT^2]$

Answer: B



Watch Video Solution

22. The dimensions of $\frac{a}{b}$ in the equation $P = \frac{a - t^2}{bx}$ where P

is pressure, x is distance and t is time are

A. $[M^2LT^{-3}]$

B. $[MT^{-2}]$

C. $[ML^3T^{-1}]$

D. $[LT^{-3}]$

Answer: B

 [Watch Video Solution](#)

23. In the equation $\int \frac{dt}{\sqrt{2at - t^2}} = a^x \sin^{-1} \left[\frac{t}{a} - 1 \right]$. The value of x is

A. 1

B. -1

C. 0

D. 2

Answer: C

 [Watch Video Solution](#)

24. The dimensions of the quantity hc (where $h = \frac{h}{2\pi}$) is

A. $[ML^2T^{-1}]$

B. $[MLT^{-1}]$

C. $[ML^3T^{-2}]$

D. $[ML^3T^{-1}]$

Answer: C



Watch Video Solution

25. A plane is inclined at an angle 30° with horizontal. The component of a vector $\vec{A} = -10\hat{k}$ perpendicular to this plane is: (here z-direction is vertically upwards)

A. $5\sqrt{2}$

B. $5\sqrt{3}e$

C. 5

D. 2.5

Answer: B



Watch Video Solution

26. Sum of magnitudes of the two forces acting at a point is $16N$ if their resultant is normal to the smaller forces and has a magnitude $8N$ then the forces are .

A. $5N, 10N$

B. $8N, 8N$

C. $4N, 12N$

D. $2N, 14N$

Answer: A



Watch Video Solution

27. The distance between the point $P(2m, 3m, 4m)$ and the x -axis

A. $\sqrt{29}m$

B. $5m$

C. $\sqrt{13}m$

D. $\sqrt{20}m$

Answer: B



Watch Video Solution

28. If the angle between the vectors A and B is θ , the value of the product $(B \times A) \cdot A$ is equal to

A. $BA^2 \cos \theta$

B. $BA^2 \sin \theta$

C. $BA^2 \sin \theta \cos \theta$

D. zero

Answer: D



Watch Video Solution

29. If \vec{a}_1 and \vec{a}_2 are two non-collinear unit vectors and if $|\vec{a}_1 + \vec{a}_2| = \sqrt{3}$, then the value of $(\vec{a}_1 - \vec{a}_2) \cdot (2\vec{a}_1 + \vec{a}_2)$ is :

A. 2

B. $3/2$

C. $1/2$

D. 1

Answer: C



Watch Video Solution

30. The significant digits in 200.40 are

A. 4

B. 5

C. 2

D. 3

Answer: B



Watch Video Solution

31. After rounding off the number 4621 to 2 significant digits the value becomes

A. 4600

B. 4620

C. 4700

D. 4720

Answer: A



Watch Video Solution

32. The area of a rectangle of size $1.23 \times 2.345\text{cm}$ is

- A. 2.88cm^2
- B. 2.884cm^2
- C. 2.9cm^2
- D. 2.88435cm^2

Answer: A



[Watch Video Solution](#)

33. The length of a rod is $(11.05 \pm 0.05)\text{cm}$. What is the length of two such rods?

- A. $(22.1 \pm 0.05)\text{cm}$
- B. $(22.10 \pm 0.05)\text{cm}$

C. $(22.1 \pm 0.10)cm$

D. $(22.10 \pm 0.10)cm$

Answer: D



Watch Video Solution

34. The relative density of material of a body is found by weighting it first in air and then in water . If the weight in air is $(5.00 \pm 0.05)N$ and the weight in water is $(4.00 \pm 0.05)N$. Find the relative density along with the maximum permissible percentage error.

A. (5.00 ± 0.05)

B. $(5.00 \pm 11 \%)$

C. (500 ± 0.10)

D. $(5.00 \pm 6 \%)$

Answer: B



Watch Video Solution

35. What is the percentage error in the measurement of time period of a pendulum if maximum errors in the measurement of l and g are 2% and 4% respectively?

A. 6 %

B. 4 %

C. 3 %

D. 5 %

Answer: C



Watch Video Solution

36. The result after adding 3.8×10^{-6} and 4.2×10^{-5} with due regards to significant figures is

A. 4.58×10^{-5}

B. 0.458×10^{-4}

C. 4.6×10^{-5}

D. 45.810^{-6}

Answer: C

37. In an experiment refractive index of glass was observed to be 1.45, 1.56, 1.54, 1.44, 1.54 and 1.53. The mean absolute error in the

experiment is

A. ± 0.04

B. 0.02

C. $- 0.03$

D. ± 0.01

Answer: A



Watch Video Solution

38. Choose the wrong statement for zero error and zero correction.

A. If the zero of the vernier scale does not coincide with the zero of the main scale then the instrument is said to be

having a zero error.

B. Zero correction has a magnitude equal to zero error but

sign is opposite to that of the zero error.

C. Zero error is positive when the zero of vernier scale lies to

the left of the zero of the main scale.

D. None of the above is wrong

Answer: C



[Watch Video Solution](#)

39. While determining the value of g using simple pendulum, we

plot a graph between l and T^2 which is

A. a straight line

B. a parabola

C. an ellipse

D. a circle

Answer: A



Watch Video Solution

40. How many number of wires are used in Searl's experiment for determining Young's modulus of elasticity ?

A. 3

B. 1

C. 2

D. 4

Answer: C

 [Watch Video Solution](#)

41. In Searl's experiment a graph is plotted between

- A. load on hanger and radius of wire
- B. load on hanger and mean value of spherometer screw reading
- C. radius of the wire and spherometer screw reading
- D. none of these

Answer: B

 [Watch Video Solution](#)

42. What type of mirror is most suitable as shaving glass?

- A. Plane mirror
- B. Convex mirror
- C. Concave mirror of large focal length
- D. Concave mirror of small focal length

Answer: C



Watch Video Solution

43. The dimensions of $\frac{1}{2}\epsilon_0 E^2$ ($\epsilon_0 =$ permittivity of free space, $E =$ electric field) is

- A. $[MLT^{-1}]$
- B. $[ML^{-1}T^{-2}]$
- C. $[MLT^{-2}]$
- D. $[ML^2T^{-1}]$

Answer: B



Watch Video Solution

44. Which of the following sets have different dimensions ?

- A. Pressure, Young's modulus, Stress
- B. Emf, Potential difference, Electric potential
- C. Heat, Work done, Energy
- D. Dipole moment, Electric flux, Electric field

Answer: D



Watch Video Solution

45. A and B are two vectors in a plane at an angle of 60° with each other. C is another vector perpendicular to the plane containing vector A and B . Which of the following relations is possible?

A. $A + B = C$

B. $A + C = B$

C. $A \times B = C$

D. $A \times C = B$

Answer: C



[View Text Solution](#)

46. Each division on the main scale is 1mm . Which of the following vernier scales give vernier constant equal to 0.01mm ?

- A. $9mm$ divided into 10 divisions
- B. $90mm$ divided into 10 divisions
- C. $99mm$ divided into 100 divisions
- D. none of these

Answer: C



Watch Video Solution

47. If vector a is a variable vector, whose magnitude is constant, then choose the statement which is always true.

- A. $\frac{da}{dt}$ is perpendicular to a
- B. $\frac{da}{dt}$ is parallel to a
- C. $\frac{da}{dt}$ is a constant vector
- D. None of these

Answer: A



Watch Video Solution

48. The length of a wire is measured with a metre scale having least count 1mm . Its diameter is measured with a vernier calipers of least count 0.1mm . Given that length and diameter of the wire are measured as 5cm and 4mm , the percentage error in the calculated value of volume of the wire will be

- A. 0.03
- B. 0.05
- C. 0.07
- D. 0.02

Answer: C



[View Text Solution](#)

49. The value of the following expression

$$\hat{i} \cdot (\hat{j} \times \hat{k}) + j \cdot (\hat{i} \times \hat{k}) + \hat{k} \cdot (\hat{j} \times \hat{i}) \text{ is}$$

A. 0

B. 1

C. -1

D. 3

Answer: C



[Watch Video Solution](#)

50. In a vernier callipers n divisions of its main scale match with $(n + 5)$ divisions on its vernier scale. Each division of the main

scale is of x unit. Using the vernier principle, find the least count.

A. $\frac{x}{n + 5}$

B. $\frac{2x}{n + 5}$

C. $\frac{5x}{n + 5}$

D. $\frac{7x}{n + 5}$

Answer: C



[View Text Solution](#)

51. If ϵ_0 , B , V represent permittivity of free space, magnitude of magnetic field and volume of space respectively, then the dimension of $\epsilon_0 B^2 V$ is $[M^a L^b T^c]$. Find $a + b + c$.

A. 8

B. 4

C. 2

D. 1

Answer: D



Watch Video Solution

52. What is the reading of micrometer screw gauge shown in figure

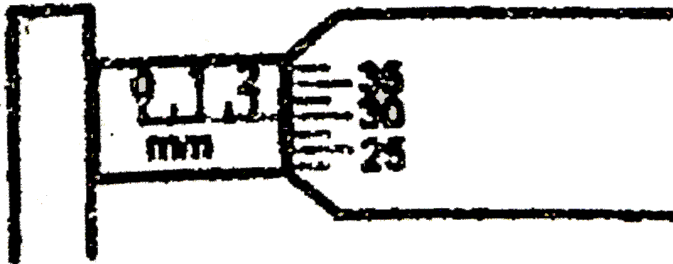

A. 2.31mm

B. 2.29mm

C. 2.36mm

D. 2.41mm

Answer: A



Watch Video Solution

53. The $|u|, |v|$ graph for a concave mirror is shown in figure.

Here $|u| > |f|$. A line passing through origin of slope 1 cut the

graph at point P . Then co-ordinate of point P are

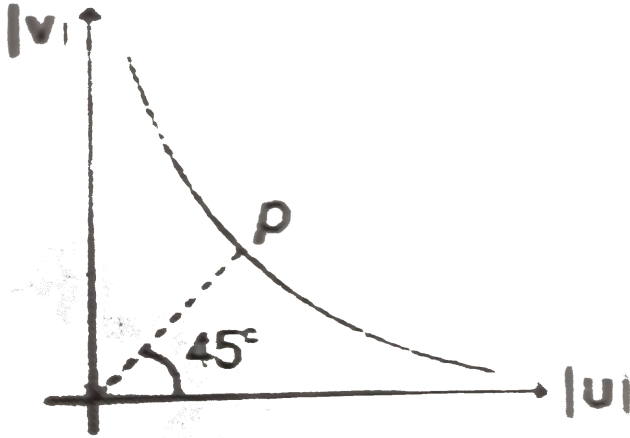

- A. $(|2f|, |2f|)$
- B. $(|2f|, |f|)$
- C. $(|f|, |2f|)$
- D. $(|f|, |f|)$

Answer: A



[View Text Solution](#)

54. For the second overtone which option shows correct mode

for displacement y and pressure variation ΔP

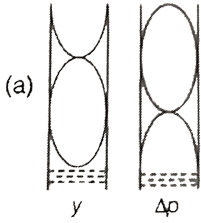

A.

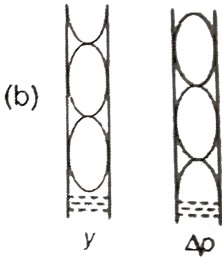

B.

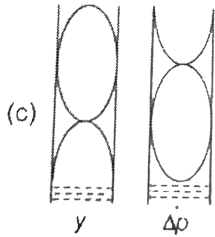

C.

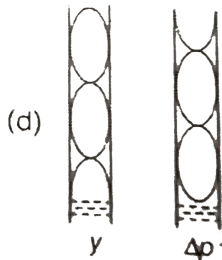

D.

Answer: B

 [Watch Video Solution](#)

55. The dimensions of a rectangular block measured with a vernier callipers having least count of 0.1mm is $5\text{mm} \times 10\text{mm} \times 5\text{mm}$. The maximum percentage error in measurement of volume of the block is

A. 0.05

B. 0.1

C. 0.15

D. 0.2

Answer: A

 [Watch Video Solution](#)

56. An unknown resistance R_1 is connected in series with a resistance of 10Ω . This combination is connected to one gap of a meter bridge, while the other gap is connected to another resistance R_2 . The balance point is at 50cm . Now, when the 10Ω resistance is removed, the balanced point shifts to 40cm . Then the value of R_1 is.

A. 60Ω

B. 40Ω

C. 20Ω

D. 10Ω

Answer: C



Watch Video Solution

57. If $a = \hat{i} + 4\hat{j} + 2\sqrt{2}\hat{k}$ and $b = (\hat{i} + \hat{j})\sqrt{2}$ then find component of a perpendicular to b

A. $\frac{5}{\sqrt{2}}$

B. $\frac{9}{\sqrt{2}}$

C. $\frac{7}{\sqrt{2}}$

D. None of these

Answer: A



[Watch Video Solution](#)

58. In a system of units if force (F), acceleration (A) and time (T) are taken as fundamental units, then the dimensional formula of energy is

A. FA^2T

B. FAT^2

C. FA^2T^3

D. FAT

Answer: B



Watch Video Solution

59. $\frac{E^2}{\mu_0}$ has the dimensions (E = electric field, μ_0 = permeability of free space)

A. $[M^2L^3T^{-2}A^2]$

B. $[MLT^{-4}]$

C. $[ML^3T^{-2}]$

D. $[M^{-1}L^2TA^{-2}]$

Answer: B



Watch Video Solution

60. The dimension of $e^2 / \epsilon_0 hc$ (here symbols have their usual meanings) are

A. $[M^0L^0T^0]$

B. $[M^2L^{-2}T^{-4}A^{-2}]$

C. $[M^3L^2T^{-2}A^2]$

D. $[L^{-3}T^2A^{-3}]$

Answer: A



Watch Video Solution

61. The dimension of σb^4 (where σ is Stefan's constant and b is Wien's constant) are $[ML^4T^{-3}]$ is it true.

A. $[M^0L^0T^0]$

B. $[ML^4T^{-3}]$

C. $[ML^{-2}T]$

D. $[ML^6T^{-3}]$

Answer: B



Watch Video Solution

62. Unit of $\frac{CV}{\rho\epsilon_0}$ are of

(C = capacitance, V = potential, ρ = specific resistance and ϵ_0 = permittivity of free space)

- A. charge
- B. current
- C. time
- D. frequency

Answer: B



[Watch Video Solution](#)

63. The sum, difference and cross produce of two vectors A and B are mutually perpendicular if

- A. A and B are perpendicular to each other and $|A| = |B|$
- B. A and B are perpendicular to each other
- C. A and B are perpendicular but their magnitude are arbitrary

D. $|A| = |B|$ and their directions are arbitrary

Answer: D



Watch Video Solution

64. If $\vec{A} \times \vec{B} = \vec{C} + \vec{D}$, then select the correct alternative.

A. B is parallel to $C + D$

B. A is perpendicular to C

C. Component of C along $A =$ component of D along A

D. Component of C along $A = -$ component of D along A

Answer: D



Watch Video Solution

65. If a , b , and c are the unit vectors along the incident ray, reflected ray and the outward normal to the reflector. Then

A. $b = a = c$

B. $b = a + (a \cdot c)c$

C. $b = 2a - c$

D. $b = a - 2(a \cdot c)c$

Answer: D



Watch Video Solution

66. The $x - y$ plane is the boundary between two transparent media. Medium-1 with $z \leq 0$ has a refractive index $\sqrt{2}$ and medium -2 with $z \geq 0$ has a refractive index $\sqrt{2}$. A ray of light in medium -1 given by vector $A = \sqrt{3}\hat{i} - \hat{k}$ is incident on the

plane of separation. The unit vector in the direction of the refracted ray in medium-2 is

A. $\frac{1}{\sqrt{2}}(\hat{k} - \hat{i})$

B. $\frac{1}{\sqrt{2}}(\hat{i} + \hat{j})$

C. $\frac{1}{\sqrt{2}}(\hat{i} - \hat{k})$

D. $\frac{1}{\sqrt{2}}(\hat{i} + \hat{k})$

Answer: C



Watch Video Solution

67. The radius of a thin wire is 0.16mm . The area of cross section taking significant figures into consideration in square millimeter is

A. 0.0804

B. 0.080

C. 0.08

D. 0.080384

Answer: C



Watch Video Solution

68. The volume of a sphere is 2.42cm^3 . The volume of 12 such spheres taking into account the significant figures is

A. 29.04cm^3

B. 29cm^3

C. 29.0cm^3

D. 29.1cm^3

Answer: C

[Watch Video Solution](#)

69. What is the reading of vernier scale shown in figure?

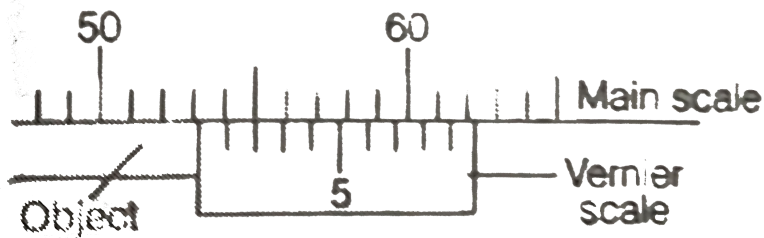

A. 54.6mm

B. 53.2mm

C. 52.7mm

D. 54.7mm

Answer: B

[Watch Video Solution](#)

70. In the formula $X = 3YZ^2$, X and Z have dimensions of capacitance and magnetic induction respectively. What are the dimensions of Y in MKSQ system?

A. $[M^{-3}L^{-1}T^3Q^4]$

B. $[M^{-3}L^{-2}T^4Q^4]$

C. $[M^{-2}L^{-2}T^4Q^4]$

D. $[M^{-3}L^{-2}T^4Q]$

Answer: B



Watch Video Solution

71. A quantity X is given by $\varepsilon_0 L \frac{\Delta V}{\Delta t}$, where ε_0 is the permittivity of free space L is a length ΔV is a potential difference and Δt is a time interval. The dimensional formula to X is the same as that of

- A. resistance
- B. charge
- C. voltage
- D. current

Answer: D



[Watch Video Solution](#)

72. A cube has a side length $1.2 \times 10^{-2} m$. Calculate its volume

A. $1.7 \times 10^{-6} m^3$

B. $1.73 \times 10^{-6} m^3$

C. $1.70 \times 10^{-6} m^3$

D. $1.732 \times 10^{-6} m^3$

Answer: A



Watch Video Solution

73. In the relation: $P = \frac{\alpha}{\beta} e^{-\frac{\alpha Z}{k\theta}}$, P is pressure Z is distance k is Boltzmann constant and θ is the temperature. The dimensional formula of β will be

A. $[M^0 L^2 T^0]$

B. $[ML^2 T^1]$

C. $[ML^0 T^{-1}]$

D. $[M^0 L^2 T^{-1}]$

Answer: A



Watch Video Solution

74. A wire has a mass (0.3 ± 0.003) g, radius (0.5 ± 0.005) mm and length (6 ± 0.06) cm. The maximum percentage error in the measurement of its density is

A. 1

B. 2

C. 3

D. 4

Answer: D



Watch Video Solution

75. A student performs an experiment for determination of $g \left[= \frac{4\pi^2 L}{T^2} \right]$, $L \approx 1m$, and he commits an error of ΔL . For T he takes the time of n oscillations with the stop watch of least count ΔT . For which of the following data, the measurement of g will be most accurate ?

- A. $\Delta l = 0.5, \Delta t = 0.1, n = 20$
- B. $\Delta l = 0.5, \Delta = 0.1, n = 50$
- C. $\Delta = 0.5, \Delta t = 0.01, n = 20$
- D. $\Delta = 0.1, \Delta t = 0.05, n = 50$

Answer: D



Watch Video Solution

76. If by mistake Ammeter is connected parallel to the resistance then $i - V$ curve expected is (Here i = reading of ammeter, V = reading of voltmeter)

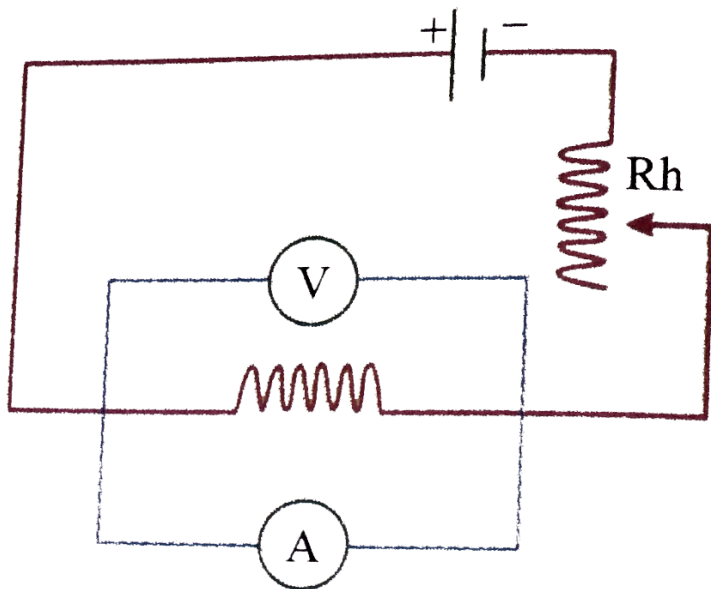

A.

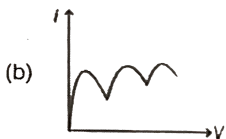

B.



C.

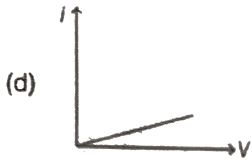

D.

Answer: C



Watch Video Solution

77. If by mistake Ammeter is connected parallel to the resistance then $i - V$ curve expected is (Here i = reading of ammeter, $V =$

reading of voltmeter)

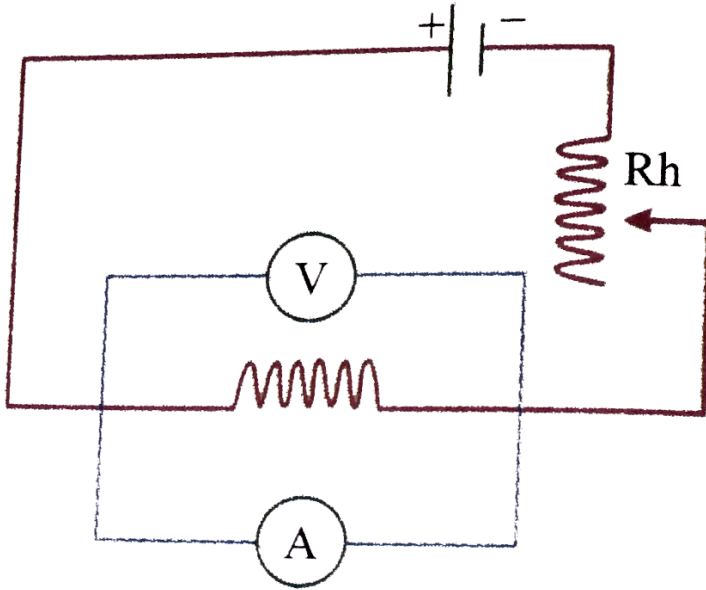

A.

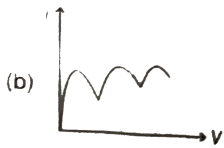

B.

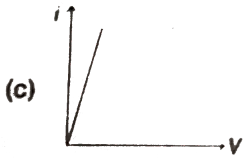

C.

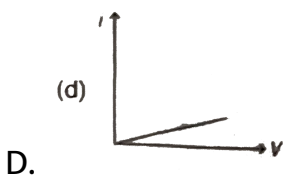

Answer: D

 [Watch Video Solution](#)

78. In meter bridge experiment if, resistance S in resistance box = 300Ω then the balanced length is found to be 25.0cm from end A . The diameter of unknown wire is 1mm and length of unknown wire is 31.4cm . The specific resistivity of the wire should be

A. $2.5 \times 10^{-4}\Omega - m$

B. $3.5 \times 10^{-4}\Omega - m$

C. $4.5 \times 10^{-4}\Omega - m$

D. None of these

Answer: A



Watch Video Solution

79. The length of a rectangular plate is measured by a meter scale and is found to be 10.0cm . Its width is measured by vernier callipers as 1.00cm . The least count of the meter scale and vernier calipers are 0.1cm and 0.01cm respectively. Maximum permissible error in area measurement is.

A. $\pm 0.2\text{cm}^2$

B. $\pm 0.1\text{cm}^2$

C. $\pm 0.3\text{cm}^2$

D. zero

Answer: A



Watch Video Solution

80. The least count of a stop watch is 0.2 s, The time of 20 oscillations of a pendulum is measured to be 25s. The percentage error in the time period is

A. 0.16

B. 0.8 %

C. 1.8 %

D. 8 %

Answer: B



Watch Video Solution

81. The pitch of a screw gauge is 0.55mm and there are 100 divisions on its circular scale. The instrument reads $+2$ divisions when nothing is put in between its jaws. In measuring the diameter of a wire, there are 8 divisions on the main scale and 83^{rd} division coincides with the reference. Then the diameter of the wire is

- A. 4.05mm
- B. 4.8455mm
- C. 3.05mm
- D. 4.8675mm

Answer: B



Watch Video Solution

82. The pitch of a screw gauge having 50 divisions on its circular scale is 1mm . When the two jaws of the screw gauge are in contact with each other, the zero of the circular scale lies 6 divisions below the line of graduation. When a wire is placed between the jaws, 3 linear scale divisions are clearly visible while 31 division on the circular scale coincides with the reference line. Find diameter of the wire.

A. 3.62mm

B. 3.50mm

C. 3.55mm

D. 3.74mm

Answer: B



Watch Video Solution

83. The smallest division on the main scale of a vernier callipers is 1mm , and 10 vernier divisions coincide with 9 main scale divisions. While measuring the diameter of a sphere the zero mark of the vernier scale lies between 2.0 and 2.1 cm and the fifth division of the vernier main scale coincide with a main scale division. Then diameter of the sphere is

A. 2.05cm

B. 3.05cm

C. 2.50cm

D. none of these

Answer: A



Watch Video Solution

84. A vernier callipers having 1 main scale division = 0.1cm to have a least count of 0.02cm . If n be the number of divisions on vernier scale and m be the length of vernier scale, then.

A. $n = 10, m = 0.5\text{cm}$

B. $n = 9, m = 0.4\text{cm}$

C. $n = 10, m = 0.8\text{cm}$

D. $n = 10, m = 0.2\text{cm}$

Answer: C



Watch Video Solution

85. The quantity $[(nh)/(2\pi qB)]^{1/2}$ where n is a positive integer, h is Planck's constant q is charge and B is magnetic field has the dimensions of

A. area

B. speed

C. length

D. acceleration

Answer: C



Watch Video Solution

86. In a meter bridge experiment, null point is obtained at 20cm from one end of the wire when resistance X is balanced against another resistance Y . If $X < Y$, then the new position of the null point from the same end, if one decides to balance a resistance of $4X$ against Y will be at.

A. 50cm

B. 80cm

C. 40cm

D. 70cm

Answer: A



Watch Video Solution

87. If vector $\vec{A} = \hat{i} + 2\hat{j} + 4\hat{k}$ and $\vec{B} = 5\hat{i}$ represent the two sides of a triangle, then the third side of the triangle can have length equal to

A. $\sqrt{56}$

B. $\sqrt{21}$

C. 5

D. 6

Answer: A

 Watch Video Solution

88. If in the shown figure $AC = \hat{i} + 2\hat{j} + 4\hat{k}$ and $BD = \hat{i} - 3\hat{j} + \hat{k}$ then BC is

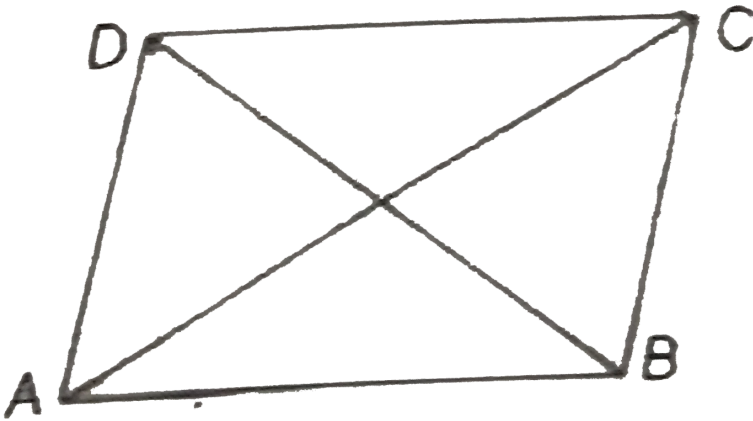

A. $\frac{3}{2}\hat{i} - \frac{1}{2}\hat{j} + 5\hat{k}$

B. $\hat{i} - \frac{1}{2}\hat{j} + \frac{5}{2}\hat{k}$

C. $2\hat{i} - \hat{j} + 5\hat{k}$

D. $\frac{3}{3}\hat{i} - 2\hat{k} + 3\hat{k}$

Answer: B



Watch Video Solution

89. A spring is placed between the jaws of screw gauge such that the spring is not all compressed. The main scale reads 2 division and circular scale reads 28 divisions. Now we turn the circular scale by 18° such that the spring is compressed. The circular scale has 200 divisions and the least count of the main scale is 1mm . What is the force exerted by the spring on the jaws if the spring constant is $100\text{N}/\text{m}$

A. 4mN

B. 3mN

C. 5mN

D. $7mN$

Answer: C



View Text Solution

90. The pitch of a screw gauge is 1 mm and there are 100 divisions on circular scale. When faces A and B are just touching each without putting anything between the studs 32nd divisions of the circular scale (below its Zero) coincides with the reference line. When a glass plate is placed between the studs, the linear scale reads 4 divisions and the circular reads 16 divisions. Find the thickness of the glass plate. Zero of linear scale is not hidden from circular scale when A and B touches each other.

A. $4.16mm$

B. $3.84mm$

C. $4.46mm$

D. $4.48mm$

Answer: B



Watch Video Solution

91. The pitch of a screw gauge is $0.5m$ and there are 50 divisions on its circular scale and one main scale division = $0.5mm$. Before starting the measurement, it is found that when jaws of the screw gauge are brought in contact, the zero of the circular scale lies 5 divisions above the reference line. When a metallic wire is placed between the jaws, four main scale divisions are clearly visible and 16^{th} division on the circular scale coincides with the reference line. The diameter of the wire is

A. $2.21mm$

B. $2.11mm$

C. $2.18mm$

D. $2.23mm$

Answer: A



[View Text Solution](#)

Mcq Type

1. The two vectors \vec{A} and \vec{B} are drawn from a common point and $\vec{C} = \vec{A} + \vec{B}$ then angle between \vec{A} and \vec{B} is

A. 90° if $C^2 = A^2 + B^2$

B. greater than 90° if $C^2 < A^2 + B^2$

C. greater than 90° if $C^2 > A^2 + B^2$

D. less than 90° if $C^2 > A^2 + B^2$

Answer: A::B::D



Watch Video Solution

2. The pairs(s) of physical quantities that have the same dimensions is (are)

A. volumetric strain and coefficient of friction

B. disintegration constant of a radioactive substance and
frequency of light wave

C. heat capacity and gravitational potential

D. Stefan's constant and Wien's constant

Answer: A::B::C



Watch Video Solution

3. If C represents capacitance and R represents resistance, then the unit of CR^2 are

A. henry

B. $\frac{\text{volt-second}}{\text{ampere}}$

C. $\frac{\text{volt}}{\text{ampere}}$

D. $\frac{\text{joule}}{\text{ampere}^2}$

Answer: A::B::D



Watch Video Solution

4. $\epsilon_0 E^2$ has the dimensions of

(ϵ_0 = permittivity of free space, E = electric field)

Here k = Boltzmann constant

T = absolute temperature

R = universal gas constant.

A. Pressure

B. kT

C. R/T

D. RT

Answer: A



Watch Video Solution

5. Which of the following quantities are independent of the choice of orientation of the co-ordinate axes?

A. $a + b$

B. $a_x + b_y$

C. $|a + b - c|$

D. angle between a and b

Answer: A::C::D



Watch Video Solution

6. Given $a + b + c + d = 0$. Which of the following statements(s) is (are) correct?

A. $a, b, c,$ and d must each be a null vector

- B. The magnitude of $a + c$ equals the magnitude of $b + d$
- C. The magnitude of a can never be greater than the sum of the magnitudes of b , c and d
- D. $b + c$ must lie in the plane of a and d if a and d are not collinear and in the line of a and d if they are collinear

Answer: B::C::D



Watch Video Solution

7. What is vernier constant?

- A. It is the value of one main scale division divided by the total number of divisions on the main scale

- B. It is the value of one vernier scale division divided by the total number of divisions on the vernier scale
- C. It is the difference between value of one main scale division and one vernier scale division
- D. It is also the least count of the vernier scale

Answer: C::D



Watch Video Solution

8. L , C and R represent the physical quantities inductance, capacitance and resistance respectively. The combinations which have the dimensions of frequency are-

A. $1/RC$

B. R/L

C. $1/\sqrt{LC}$

D. C/L

Answer: A::B::C



Watch Video Solution

9. The dimensions of the quantities in one (or more) of the following pairs are the same . Identify the pair(s)

A. torque and work

B. angular moment and work

C. energy and Young's modulus

D. light year and wavelength

Answer: A::D

 [Watch Video Solution](#)

10. The pairs of physical quantities that have the same dimensions is (are):

- A. Reynolds number and strain
- B. Curie and frequency of a light wave
- C. Latent heat and gravitational potential
- D. Planck's constant and torque

Answer: A::B::C

 [Watch Video Solution](#)

11. Let $[\epsilon_0]$ denote the dimensional formula of the permittivity of the vacuum, and $[\mu_0]$ that of the permeability of the vacuum. If

$M = \text{mass}, L = \text{length}, T = \text{time}$ and $I = \text{electric current}$

,

A. $[\epsilon_0] = [M^{-1}L^{-3}T^2I]$

B. $[\epsilon_0] = [M^{-1}L^{-3}T^4I^2]$

C. $[\mu_0] = [MLT^{-2}I^{-2}]$

D. $[\mu_0] = [ML^2T^{-1}I]$

Answer: B::C::D



Watch Video Solution

12. The SI unit of inductance, the henry can be written as

A. weber/ampere

B. volt-second/ampere

C. joule / (ampere)²

D. ohm-second

Answer: A::B::C::D



Watch Video Solution

13. In the searle's experiment, after every step of loading, why should we wait for two minutes before taking the reading?(

More than one options may be correct).

A. So that the wire can have its desired change in length

B. So that the wire can room temperature

C. So that vertical oscillations can get subsided

D. So that the wire has no change in its radius.

Answer: A::B::C



Watch Video Solution

14. The vector $\hat{i} + x\hat{j} + 3\hat{k}$ is rotated through an angle θ and doubled in magnitude then it becomes $4\hat{i} + (4x - 2)\hat{j} + 2\hat{k}$.

The values of x are

A. $-\frac{2}{3}$

B. $\frac{1}{3}$

C. $\frac{2}{3}$

D. 2

Answer: A::D



Watch Video Solution

15. In an experiment to determine the acceleration due to gravity g , the formula used for the time period of a periodic motion is $T = 2\pi\sqrt{\left(7\frac{R-r}{5g}\right)}$. The values of R and r are measured to be $(60 \pm 1)mm$ and $(10 \pm 1)mm$, respectively. In five successive measurements, the time period is found to be $0.52s$, $0.56s$, $0.57s$, $0.54s$ and $0.59s$. The least count of the watch used for the measurement of time period is $0.01s$. Which of the following statements (s) is (are) true?

- A. The error in the measurement of r is 10 %
- B. The error in the measurement of T is 3.57 %
- C. The error in the measurement of T is 2 %
- D. The error in the determined value of g is 11 %

Answer: A::B::D



Watch Video Solution

16. The sides of a cube is 8cm . The volume of the cube with due respect to significant figure is

A. 50cm^3

B. 512cm^3

C. 510cm^3

D. $5.12 \times 10^2\text{cm}^3$

Answer: A::D



Watch Video Solution

17. The pitch of screw gauge is 1mm and its circular scale is divided into 100 divisions. When nothing is put between the

studs, the zero of main scale is not seen, but when circular scale is rotated by 450° the zero of main scale is seen and the zero of main scale coincides with the zero of circular scale. When a glass plate is placed between the studs, the circular scale lies between 18^{th} and 19^{th} division of main scale and circular scale reads 34 divisions. Then

- A. Error is positive zero error and its magnitude is $1.25mm$
- B. Error is negative zero error and its magnitude is $1.25mm$
- C. The thickness of the glass plate is $19.59mm$
- D. The thickness of the glass plate is $17.09mm$

Answer: B::C



Watch Video Solution

Match The Column

1. Match the following

Table-1	Table-2
(A) R/L	(P) Time
(B) CR	(Q) Frequency
(C) E/B	(R) Speed
(D) $\sqrt{\epsilon_0\mu_0}$	(S) None



[Watch Video Solution](#)

2. Match the following

Table-1	Table-2
(A) Stress	(P) Pressure
(B) Strain	(Q) Energy density
(C) Modulus of elasticity	(R) Angle
(D) Torque	(S) Energy



[Watch Video Solution](#)

3. Suppose force (F) , area (A) and time (T) are the fundamental units, then match the following

Table-1	Table-2
(A) Work	(P) $[A^{1/2}T^{-1}]$
(B) Moment of inertia	(Q) $[FA^{1/2}]$
(C) Velocity	(R) $[FA^{1/2}T^2]$

 [Watch Video Solution](#)

4. Match the following

Table-1	Table-2
(A) Electrical resistance	(P) $[M^{-1}L^{-2}T^4A^2]$
(B) Capacitance	(Q) $[ML^2T^{-2}A^{-2}]$
(C) Magnetic field	(R) $[ML^2T^{-3}A^{-2}]$
(D) Inductance	(S) $[MT^{-2}A^{-1}]$

 [Watch Video Solution](#)

5. Match the following

Table-1	Table-2
(A) Specific heat	(P) $[ML^2 T^{-2} \theta^{-1}]$
(B) Boltzmann constant	(Q) $[MT^{-3} \theta^{-4}]$
(C) Wien's constant	(R) $[L\theta]$
(D) Stefan's constant	(S) $[L^2 T^{-2} \theta^{-1}]$



[Watch Video Solution](#)

6. For component of a vector $A = (3\hat{i} + 4\hat{j} - 5\hat{k})$, match the following table

Table-1	Table-2
(A) Along y-axis	(P) 5 unit
(B) Along another vector $(2\hat{i} + \hat{j} + 2\hat{k})$	(Q) 4 unit
(C) Along $(6\hat{i} + 8\hat{j} - 10\hat{k})$	(R) Zero
(D) Along another vector $(-3\hat{i} - 4\hat{j} + 5\hat{k})$	(S) None



[Watch Video Solution](#)

1. If the dimensions of B^2l^2C are $[M^aL^bT^c]$, then the value of $a + b + c$ is

[Here B , l and C represent the magnitude of magnetic field, length and capacitance respectively]



[Watch Video Solution](#)

2. The main scale of a vernier callipers reads in millimeter and its vernier is divided into ten divisions, which coincide with seven divisions of main scale. Further when a cylinder is tightly placed along its length between two jaws, it is observed that the zero of vernier scale just right to 32 division of main scale and fourth division of vernier scale coincides with the main scale. Then the measured value is $0.83K\text{ cm}$. Find the value of K .



Watch Video Solution