



PHYSICS

BOOKS - DC PANDEY PHYSICS (HINGLISH)

WORK, POWER AND ENERGY

Only One Option Is Correct

1. A block of mass m is suspended by a light thread from an elevator. The elevator is accelerating upward with uniform acceleration a . The work done by tension on the block during t

seconds is ($u = 0$)

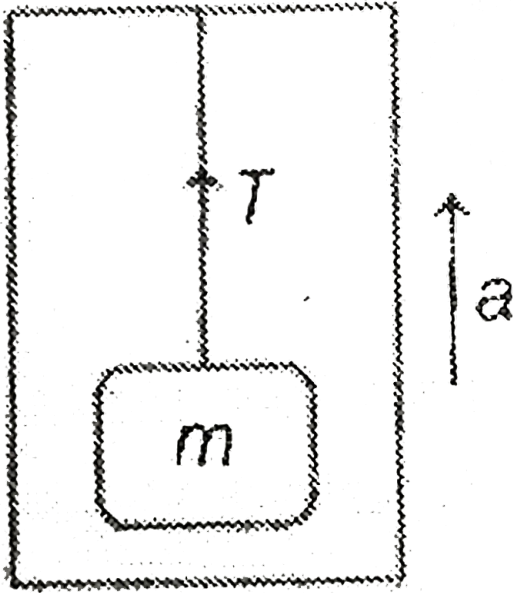

A. $\frac{m}{2}(g + a)at^2$

B. $\frac{m}{2}(g - a)at^2$

C. $\frac{m}{2}gat^2$

D. 0

Answer: A



Watch Video Solution

2. The graph between the resistance force F acting on a body and the distance covered by the body is shown in the figure. The mass of the body is 25kg and initial velocity is 2m/s . When the distance covered by the body is 4m , its kinetic energy would be

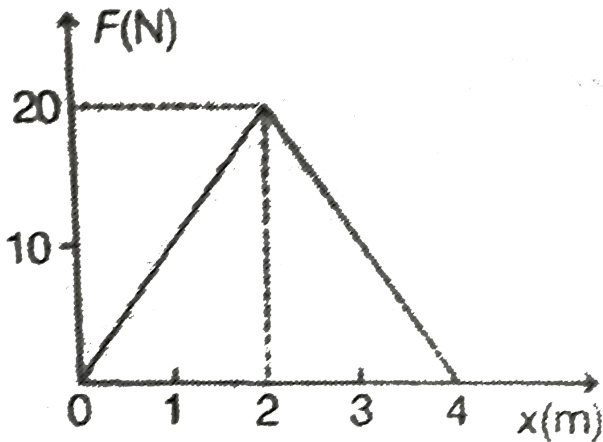

- A. 50 J
- B. 40 J
- C. 90 J
- D. 10 J

Answer: D

[Watch Video Solution](#)

3. A block weighing 10 N travels down a smooth curved track AB joined to a rough horizontal surface (figure). The rough surface has a friction coefficient of 0.20 with the block. If the block is released from rest on the track from a point 1.0 m above the horizontal surface, the distance it will move on the rough surface is

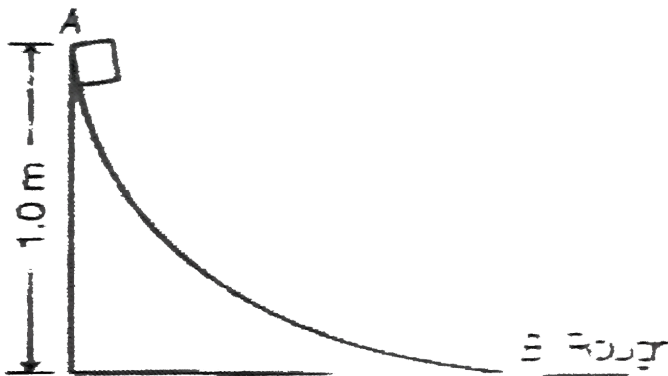

- A. 5.0 m
- B. 10.0 m
- C. 15.0 m
- D. 20.0 m

Answer: A

 [Watch Video Solution](#)

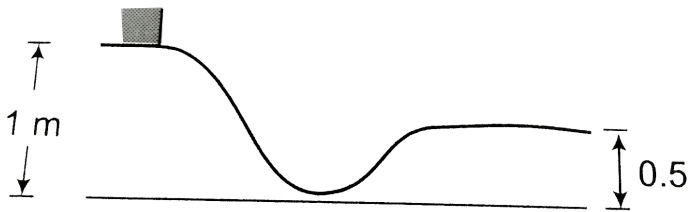

4.

The figure shown a particle sliding on a frictionless track, which terminates in a straight horizontal section. If the particle starts

slipping from the point A , how far away from the track will the particle hit the ground?

- A. At a horizontal distance of 1m from the end of the track
- B. At a horizontal distance of 2m from the end of the track
- C. At a horizontal distance of 3m from the end of the track
- D. Insufficient information

Answer: A



[Watch Video Solution](#)

5. A block of mass m is attached to two unstretched springs of springs constant k_1 and k_2 as shown in figure. The block is displaced towards right through a distance x and is released. Find the speed of the block as it passes through the mean

position shown.

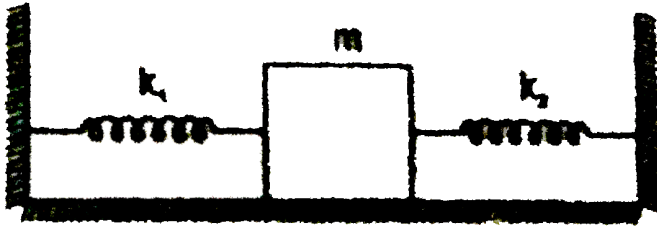

A. $\frac{k_1 + k_2}{m} \times$

B. $\frac{k_1 k_2}{m(k_1 + k_2)} \times$

C. $\sqrt{\frac{k_1^2 k_2^2}{m(k_1 + k_2)}} \times$

D. None of these

Answer: A



Watch Video Solution

6. A body of mass m dropped from a certain height strikes a light vertical fixed spring of stiffness k . the height of its fall

before touching the spring the if the maximum compression of the spring the equal to $\frac{3mg}{k}$ is

A. $\frac{3mg}{2k}$

B. $\frac{2mg}{k}$

C. $\frac{3mg}{4k}$

D. $\frac{mg}{4k}$

Answer: A



Watch Video Solution

7. Potential energy v/s position curve for one dimensional conservative field is shown. Force at A and B is respectively.

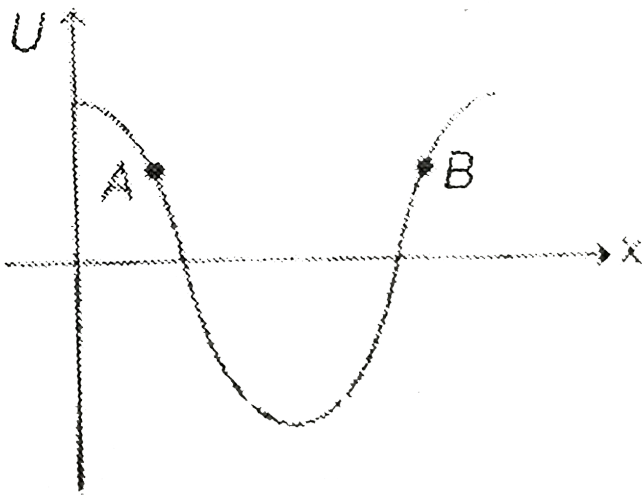

- A. Positive, Positive
- B. Positive, Negative
- C. Negative, Positive
- D. Negative, Negative

Answer: B

 [Watch Video Solution](#)

8. Force acting on a block moving along x-axis is given by

$$F = - \left(\frac{4}{x^2 + 2} \right) N$$

The block is displaced from $x = -2m$ to $x = +4m$, the work done will be

- A. positive
- B. negative
- C. zero
- D. may be positive or negative

Answer: B



[Watch Video Solution](#)

9. A block of mass 50 kg is projected horizontal on a rough horizontal floor. The coefficient of friction between the block

and the floor is 0.1. The block strikes a light spring of stiffness $k = 100\text{ N/m}$ with a velocity 2 m/s , the maximum compression of the spring is

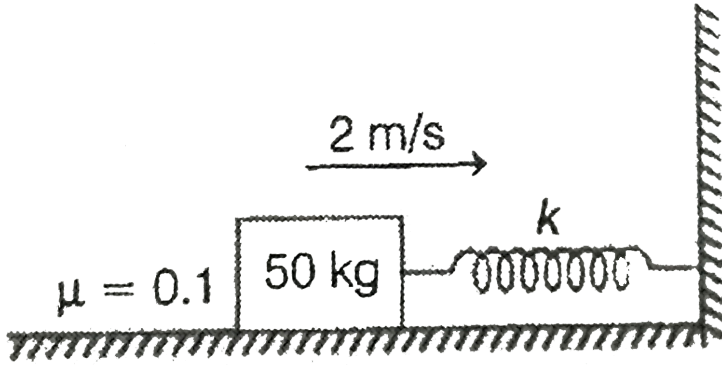

- A. 1 m
- B. 2 m
- C. 3 m
- D. 4 m

Answer: A



Watch Video Solution

10. A block of mass 250 g is kept on a vertical spring of spring constant 100 N/m fixed from below. The spring is now compressed to have length 10 cm shorter than its natural length and the system is released from this position. How high does the block rise? take $g = 10 \frac{m}{s^2}$.

- A. 20 cm
- B. 30 cm
- C. 40 cm
- D. 50 cm

Answer: A



Watch Video Solution

11. The potential energy of the system is represented in the first figure. The force acting on the system will be represented by

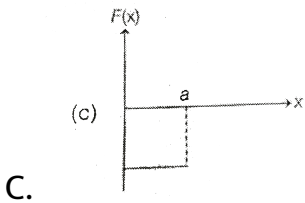
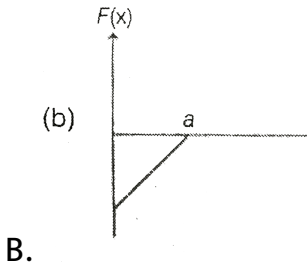
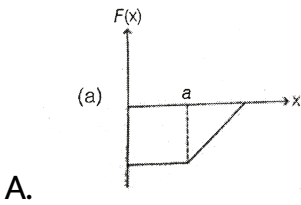
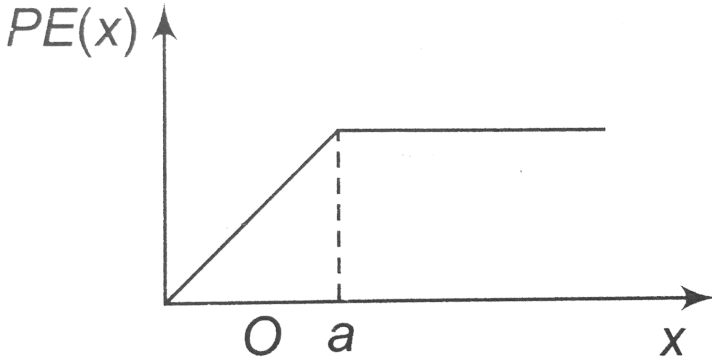

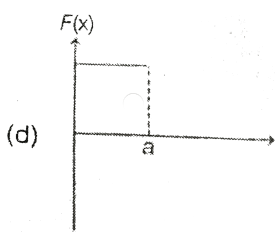

D.

Answer: C

 [Watch Video Solution](#)

12. $F = 2x^2 - 3x - 2$. Choose correct option.

- A. $x = -1/2$ is position of stable equilibrium
- B. $x = 2$ is position of stable equilibrium
- C. $x = -1/2$ is position of unstable equilibrium
- D. $x = 2$ is position of neutral equilibrium

Answer: A





Watch Video Solution

13. A block of mass m is hung vertically from an elastic thread of force constant mg/a . Initially the thread was at its natural length and the block is allowed to fall freely. Kinetic energy of the block when it passes through the equilibrium position will be

A. mga

B. $\frac{mga}{2}$

C. zero

D. $2mga$

Answer: B



Watch Video Solution

14. A block of mass m tied to a string is lowered by a distance d , at a constant acceleration of $g/3$. The work done by the string is

A. $\frac{mgd}{3}$

B. $\frac{-mgd}{3}$

C. $\frac{2}{3}mgd$

D. $\frac{-2}{3}mgd$

Answer: D



Watch Video Solution

15. From the fixed pulley, masses 2kg, 1kg and 3kg are suspended as shown in the figure. Find the extension in the spring if

$k = 100\text{N}/\text{m}$. (Neglect oscillations due to spring)

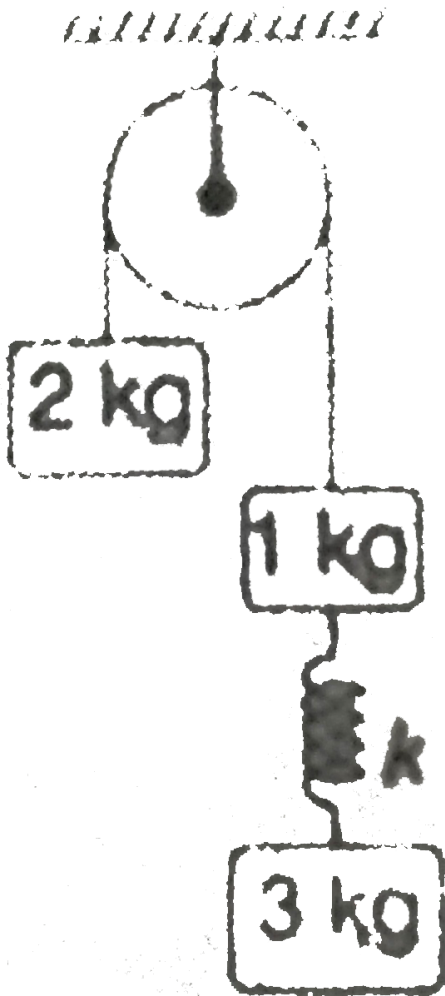

A. 0.1m

B. 0.2m

C. 0.3m

D. 0

Answer: B



Watch Video Solution

16. A rope of length l and mass ' m ' is connected to a chain of length l and mass $2m$ and hung vertically as shown. What is the change in gravitational potential energy if the system is inverted

and hung from same point.

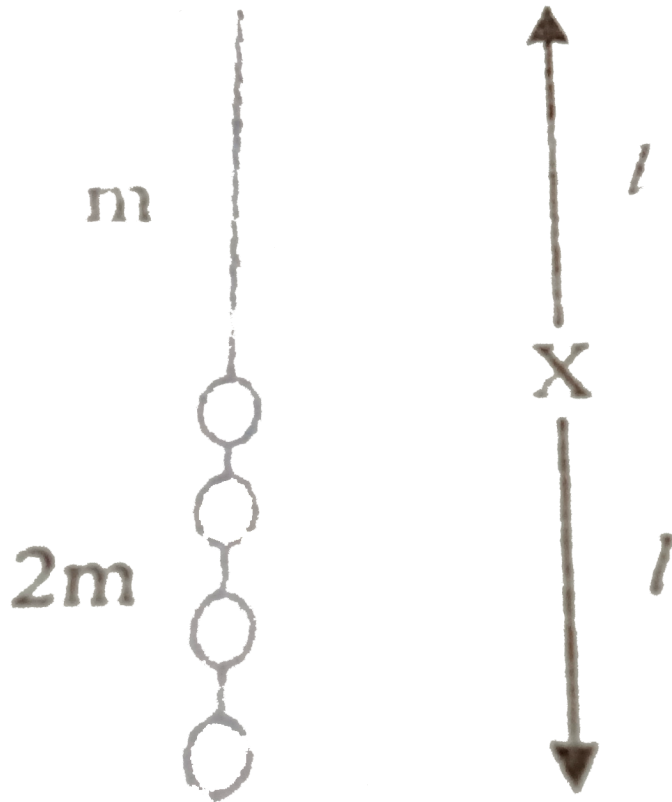

- A. mg
- B. $1.5 mg$
- C. $0.5 mg$
- D. $2 mg$

Answer: A



Watch Video Solution

17. $v-t$ graph of an object of mass 1 kg is shown. Select the wrong statement-



- A. Work done on the object in 30 s is zero.
- B. The average acceleration of the object is zero.
- C. The average velocity of the object is zero.
- D. The average force on the object is zero.

Answer: C



Watch Video Solution

18. A 15gm ball is shot from a spring whose spring has a force constant of $600\text{N}/\text{m}$. The spring is compressed by 5cm . The greater possible horizontal range of the ball for this compression is

- A. 6.0 m
- B. 12.0 m
- C. 10.0 m
- D. 8.0 m

Answer: C



[Watch Video Solution](#)

19. Power supplied to a mass 2kg varies with time as $P = \frac{3t^2}{2}$ watt. Here t is in second . If velocity of particle at $t = 0$ is $v = 0$,

the velocity of particle at time $t = 2s$ will be:

A. $1m / s$

B. $4m / s$

C. $2m / s$

D. $2\sqrt{2}m / s$

Answer: C



Watch Video Solution

20. A ball is released from the top of a tower. The ratio of work done by force of gravity in 1st second, 2nd second and 3rd second of the motion of ball is

A. $1 : 2 : 3$

B. $1 : 4 : 16$

C. 1 : 3 : 5

D. 1 : 9 : 25

Answer: C



Watch Video Solution

21. A particle is released from height H . At certain height from the ground its kinetic energy is twice its gravitational potential energy. Find the height and speed of particle at that height.

A. $\frac{H}{3}, \sqrt{\frac{2gH}{3}}$

B. $\frac{H}{3}, 2\sqrt{\frac{gH}{3}}$

C. $\frac{2H}{3}, \sqrt{\frac{2gH}{3}}$

D. $\frac{H}{3}, \sqrt{2gH}$

Answer: B



Watch Video Solution

22. A body is moved along a straight line by a machine delivering constant power . The distance moved by the body in time t is proportional to

A. $t^{1/2}$

B. $t^{3/4}$

C. $t^{3/2}$

D. t^2

Answer: C



Watch Video Solution

23. The displacement of a body of mass 2kg varies with time t as $S = t^2 + 2t$, where S is in seconds. The work done by all the forces acting on the body during the time interval $t = 2\text{s}$ to $t = 4\text{s}$ is

A. 36 J

B. 64 J

C. 100 J

D. 120 J

Answer: B



[Watch Video Solution](#)

24. The work done by a force $\vec{F} = (-6x^3\hat{i})$ N in displacing a particle from $x = 4\text{m}$ to $x = -2\text{m}$ is

A. $240J$

B. $360 J$

C. $420 J$

D. will depend upon the path

Answer: B



Watch Video Solution

25. The velocity-time graph of a particle moving in a straight line is shown in figure. The mass of the particle is $2kg$. Work done by all the forces acting on the particle in time interval between

$t = 0$ to $t = 10\text{s}$ is

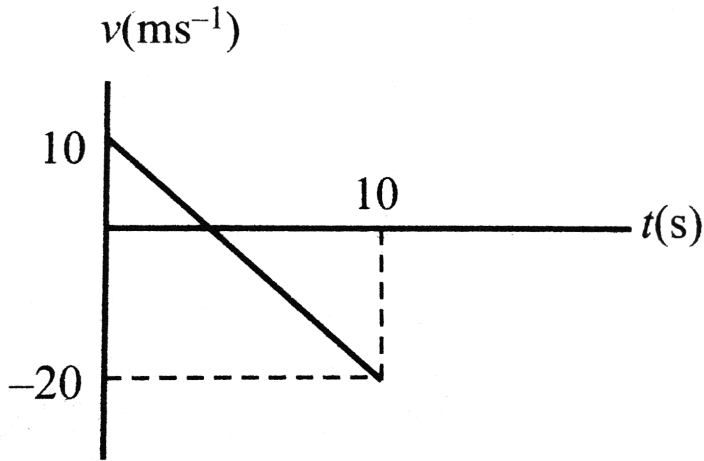

- A. 300 J
- B. -300 J
- C. 400 J
- D. -400 J

Answer: A



Watch Video Solution

26. The force acting on a body moving along x -axis varies with the position of the particle as shown in the fig. The body is in stable equilibrium at.

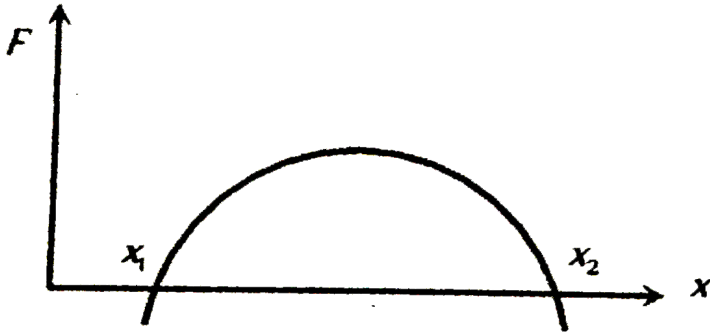

- A. $x = x_1$
- B. $x = x_2$
- C. Both x_1 and x_2
- D. Neither x_1 and x_2

Answer: B



Watch Video Solution

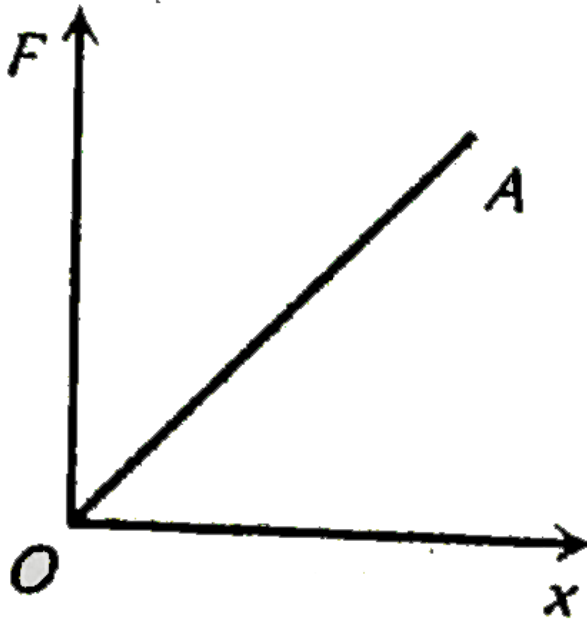

27.

The force required to stretch a spring varies with the distance as shown in the figure. If the experiment is performed with the above spring of half length, the line OA will

- A. shift towards F axis
- B. shift towards
- C. X-axis

D. remain as it is

Answer: A



Watch Video Solution

28. A force F acting on a body depends on its displacement S as $F \propto S^{-1/3}$. The power delivered by F will depend on displacement as

A. $s^{2/3}$

B. $s^{-5/3}$

C. $s^{1/2}$

D. s^0

Answer: D



Watch Video Solution

29. A man throws the bricks to a height of 12 m where they reach with a speed of 12 m/s . If he throws the bricks such that they just reach that height, what percentage of energy will be saved?

$$(g = 9.8\text{ m/s}^2)$$

A. 0.29

B. 0.46

C. 0.38

D. 0.5

Answer: C

30. The ratio of momentum and kinetic energy of particle is inversely proportional to the time. Then, this is the case of a

- A. uniformly accelerated motion
- B. uniform motion
- C. uniformly retarded motion
- D. simple harmonic motion

Answer: A



[Watch Video Solution](#)

31. A block of mass m is pulled by a constant power P placed on a rough horizontal plane. The friction coefficient the block and surface is μ . The maximum velocity of the block is.

A. $\frac{\mu P}{mg}$

B. $\frac{\mu mg}{P}$

C. μmgP

D. $\frac{P}{\mu mg}$

Answer: D



Watch Video Solution

32. An object of mass m is allowed to fall from rest along a rough inclined plane. The speed of the object on reaching the bottom of the plane is proportional to:

A. m^0

B. m

C. m^2

D. m^{-1}

Answer: A



Watch Video Solution

33. A particle is moved from $(0, 0)$ to (a, a) under a force a $F = (3\hat{i} + 4\hat{j})$ from two paths. Path 1 is OP and path 2 is OPQ. Let W_1 and W_2 be the work done by this force in these two paths. Then,

A. $W_1 = W_2$

B. $W_1 = 2W_2$

C. $W_2 = 2W_1$

D. $W_2 = 4W_1$

Answer: A



Watch Video Solution

34. A particle of mass 0.5kg is displaced from position $\vec{r}_1(2, 3, 1)$ to $\vec{r}_2(4, 3, 2)$ by applying a force of magnitude 30N which is acting along $(\hat{i} + \hat{j} + \hat{k})$. The work done by the force is

A. $10\sqrt{3}\text{J}$

B. $30\sqrt{3}\text{J}$

C. 30J

D. None of these

Answer: B



Watch Video Solution

35. A uniform flexible chain of mass m and length $2l$ hangs in equilibrium over a smooth horizontal pin of negligible diameter. One end of the chain is given a small vertical displacement so that the chain slips over the pin. The speed of chain when it leaves the pin is

A. $\sqrt{2gl}$

B. \sqrt{gl}

C. $\sqrt{4gl}$

D. $\sqrt{3gl}$

Answer: B



Watch Video Solution

36. A block is released from the top of a smooth inclined plane of inclination θ as shown in figure. Let v be the speed of the particle after travelling a distance s down the plane. Then which of the following will remain constant ?

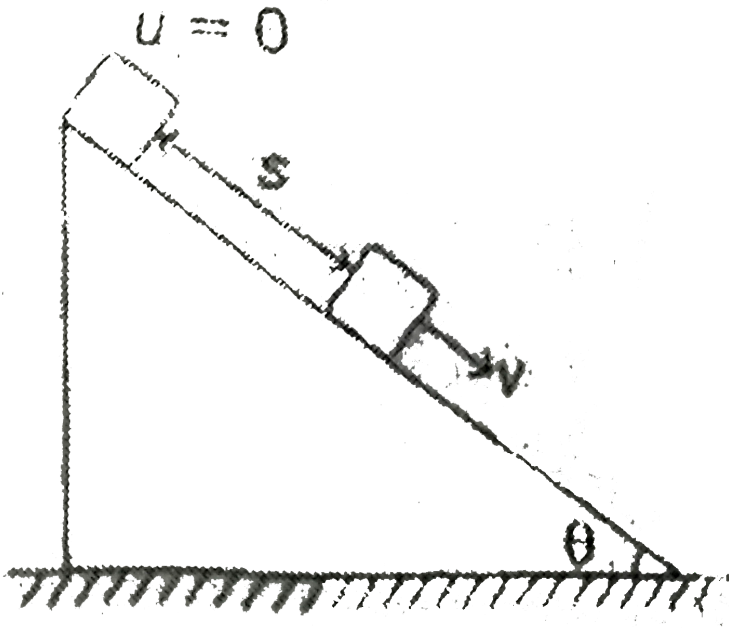

A. $v^2 + 2gs \sin \theta$

B. $v^2 - 2gs \sin \theta$

C. $v - \sqrt{2gs \sin \theta}$

$$D. v + \sqrt{2gs} \sin \theta$$

Answer: B



Watch Video Solution

37. Suppose y represents the work done and x the power, then dimensions of $\frac{d^2y}{dx^2}$ will be

A. $[M^{-1}L^{-2}T^4]$

B. $[M^2L^{-3}T^{-2}]$

C. $[M^{-2}L^{-4}T^4]$

D. $[ML^3T^{-6}]$

Answer: A



Watch Video Solution

38. A spring and block are placed on a fixed smooth wedge as shown. Following conclusions can be drawn for the block.

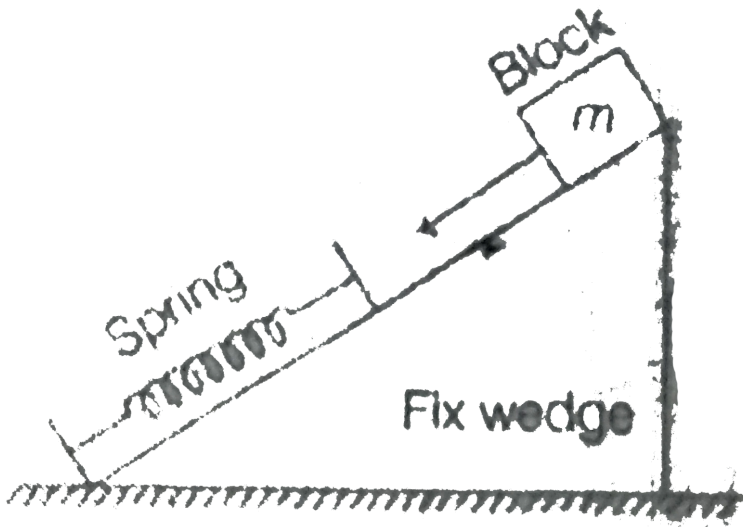

- (i) magnitude of its momentum will be maximum when F_{net} on block is zero
- (ii) its kinetic energy will be maximum when F_{net} on block is zero
- (iii) kinetic energy of block is maximum when block just touches the spring
- (iv) net force on block is maximum when $\text{KE} = 0$

A. (i), (iii), (iv)

B. (ii), (iii), (iv)

C. (i), (ii), (iii)

D. (i), (ii), (iv)

Answer: D



Watch Video Solution

39. The kinetic energy (KE) versus time graph for a particle moving along a straight line is as shown in the figure. The force

versus time graph for the particle may be

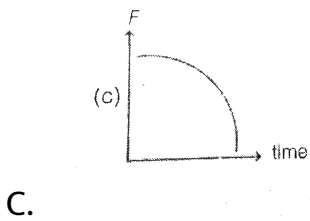
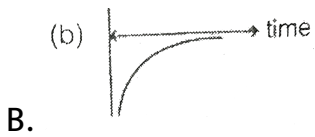
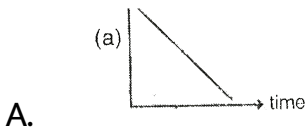
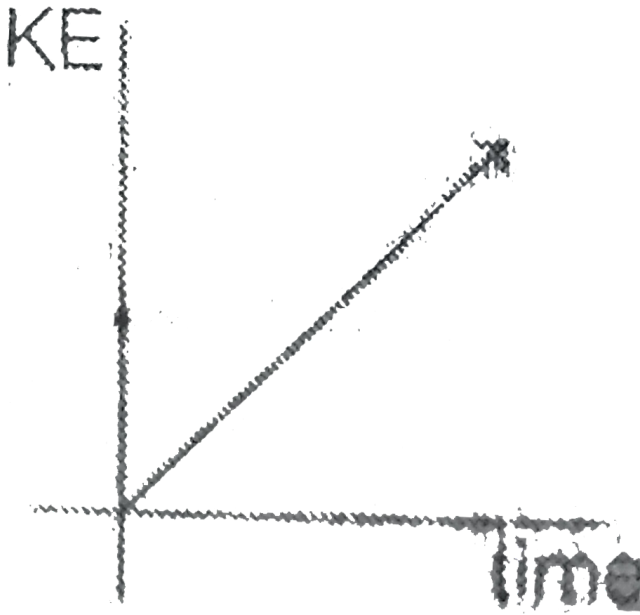

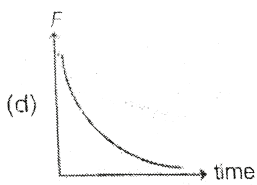

Answer: D

 [Watch Video Solution](#)

A Only One Option Is Correct

1. Kinetic energy of a particle moving in a straight line varies with time t as $K = 4t^2$. The force acting on the particle

- A. is constant
- B. is increasing
- C. is decreasing
- D. first increases and then decreases

Answer: A



Watch Video Solution

2. A particle of mass $2kg$ starts moving in a straight line with an initial velocity of $2m/s$ at a constant acceleration of $2m/s^2$. Then rate of change of kinetic energy.

- A. is four times the velocity at any moment
- B. is two times the displacement at any moment
- C. is four times the rate of change of velocity at any moment
- D. is constant throughout

Answer: A



Watch Video Solution

3. A particle moves on the rough horizontal ground with some initial velocity V_0 . If $\frac{3}{4}$ of its kinetic energy is lost due to friction in time t_0 . The coefficient of friction between the particle and the ground is.

A. $\frac{v_0}{2gt_0}$

B. $\frac{v_0}{4gt_0}$

C. $\frac{3v_0}{4gt_0}$

D. $\frac{v_0}{gt_0}$

Answer: A



Watch Video Solution

4. Two particles 1 and 2 are allowed to descend on the two frictionless chords OA and OB of a vertical circle, at the same

instant from point O . The ratio of the velocities of the particles 1 and 2 respectively, when they reach on the circumference will be (OB is the diameter).

A. $\frac{1}{4}$

B. $\frac{1}{2}$

C. 1

D. $\frac{1}{2\sqrt{2}}$

Answer: B



Watch Video Solution

5. A body is displaced from $(0, 0)$ to $(1m, 1m)$ along the path $x = y$ by a force $F = (x^2\hat{j} + y\hat{i})N$. The work done by this force will be

A. $\frac{4}{3}J$

B. $\frac{5}{6}J$

C. $\frac{3}{2}J$

D. $\frac{7}{5}J$

Answer: B



Watch Video Solution

6. A self-propelled vehicle of mass m , whose engine delivers a constant power P , has an acceleration $a = (P/mv)$. (Assume that there is no friction). In order to increase its velocity from v_1 to v_2 , the distance it has to travel will be:

A. $\frac{3P}{m}(v_2^2 - v_1^2)$

B. $\frac{m}{3P}(v_2 - v_1)$

C. $\frac{m}{3P} (v_2^3 - v_1^3)$

D. $\frac{m}{3P} (v_2^2 - v_1^2)$

Answer: C



Watch Video Solution

7. A body is moved from rest along a straight line by a machine delivering constant power. The ratio of displacement and velocity (s/v) varies with time t as

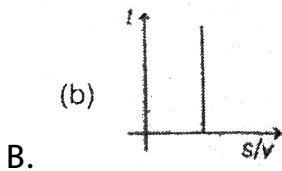
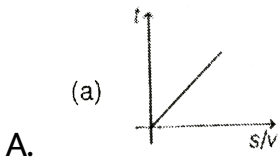

(c)



C.

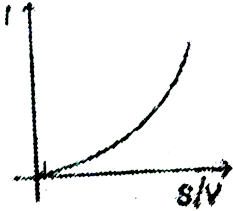

D.

Answer: A



Watch Video Solution

8. A force $F = (2\hat{i} + 5\hat{j} + \hat{k})N$ is acting on a particle. The particle is first displacement from $(0, 0, 0)$ to $(2m, 2m, 0)$ along the path $x = y$ and then from $(2m, 2m, 0)$ to $(2m, 2m, 2m)$ along the path $x = 2m, y = 2m$. The total work done in the complete path is

A. 12 J

B. 8 J

C. 16 J

D. 10 J

Answer: C



Watch Video Solution

9. A vertical spring of force constant $100\text{N}/\text{m}$ is attached with a hanging mass of 10 kg. Now an external force is applied on the mass so that the spring is stretched by additional 2m. The work

done by the force F is ($g = 10\text{ m/s}^2$)

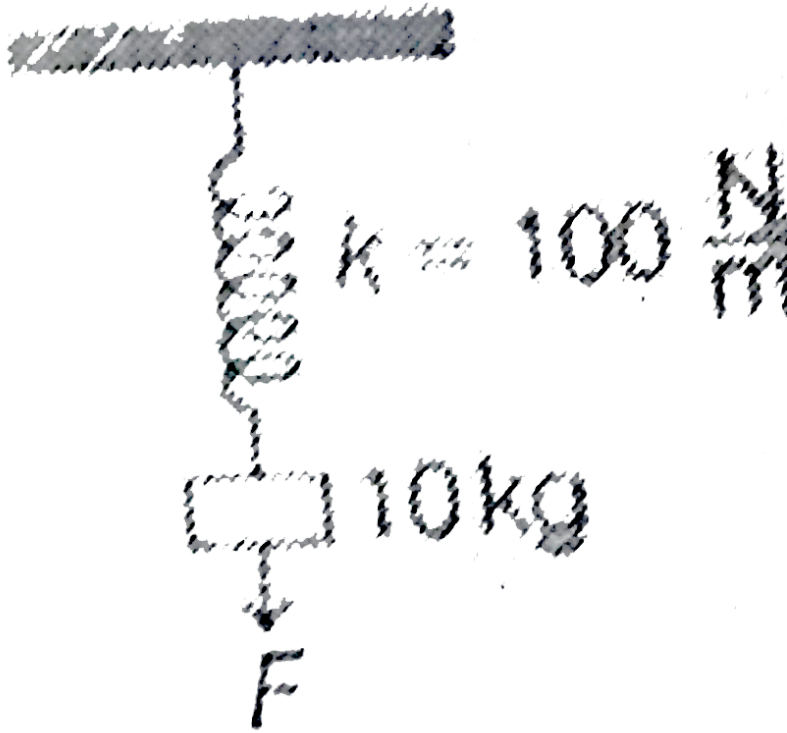

- A. 200 J
- B. 400 J
- C. 450 J
- D. 600 J

Answer: A



Watch Video Solution

10. A particle is released from the top of two inclined rough surfaces of height h each. The angle of inclination of the two planes are 30° and 60° respectively. All other factors (e.g. coefficient of friction, mass of the block etc) are same in both the cases. Let K_1 and K_2 be the kinetic energy of the particle at the bottom of the plane in two cases. Then

A. $K_1 = K_2$

B. $K_1 > K_2$

C. $K_1 < K_2$

D. Data insufficient

Answer: C



Watch Video Solution

11. System shown in figure is released from rest . Pulley and spring is mass less and friction is absent everywhere. The speed of 5kg block when 2kg block leaves the constant of with ground

is (force constant of spring $k = 40N/m$ and $g = 10m/s^2$)

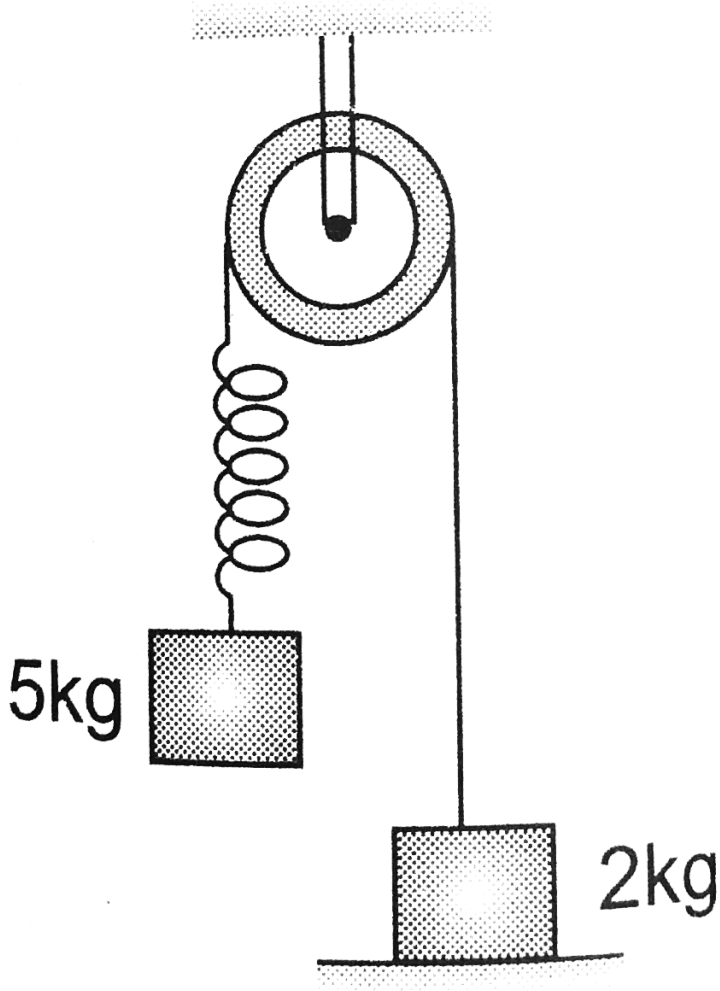

A. $\sqrt{2}m/s$

B. $2\sqrt{2}m/s$

C. $2m / s$

D. $4\sqrt{2}m / s$

Answer: B



Watch Video Solution

12. Force acting on a particle is $(2\hat{i} + 3\hat{j})N$. Work done by this force is zero, when the particle is moved on the line $3y + kx = 5$. Here value of k is (Work done $W = \vec{F} \cdot \vec{d}$)

A. 2

B. 4

C. 6

D. 8

Answer: A



Watch Video Solution

13. An object of mass m slides down a hill of arbitrary shape and after travelling a certain horizontal path stops because of friction. The total vertical height descended is h . The friction coefficient is different for different segments for the entire path but is independent of the velocity and direction of motion. The work that a tangential force must perform to return the object to its initial position along the same path is

- A. mgh
- B. $2 mgh$
- C. $4 mgyh$
- D. $-mgh$

Answer: B



Watch Video Solution

14. A block of mass m slides down a rough inclined plane of inclination θ with horizontal with zero initial velocity. The coefficient of friction between the block and the plane is μ with $\theta > \tan^{-1}(\mu)$. Rate of work done by the force of friction at time t is

A. $\mu mg^2 t \sin \theta$

B. $mg^2 t (\sin \theta - \mu \cos \theta)$

C. $\mu mg^2 t \cos \theta (\sin \theta - \mu \cos \theta)$

D. $\mu mg^2 t \cos \theta$

Answer: C



Watch Video Solution

15. A $1.5 - kg$ block is initially at rest on a horizontal frictionless surface when a horizontal force in the positive direction of x-axis is applied to the block. The force is given by $\vec{F} = (4 - x^2) \vec{i} N$, where x is in meter and the initial position of the block is $x = 0$. The maximum kinetic energy of the block between $x = 0$ and $x = 2.0m$ is

- A. 2.33 J
- B. 8.67 J
- C. 5.33 J
- D. 6.67 J

Answer: C



Watch Video Solution

16. In the above problem, the maximum positive displacement x is

A. $2\sqrt{3}m$

B. 2 m

C. 4 m

D. $\sqrt{2}m$

Answer: A



[View Text Solution](#)

17. A block of mass 1 kg is attached to one end of a spring of force constant $k = 20\text{ N/m}$. The other end of the spring is attached to a fixed rigid support. This spring block system is

made to oscillate on a rough horizontal surface ($\mu = 0.04$). The initial displacement of the block from the equilibrium position is $a = 30$ cm. How many times the block passes from the mean position before coming to rest ? ($g = 10\text{m} / \text{s}^2$)

A. 11

B. 7

C. 6

D. 15

Answer: B



[Watch Video Solution](#)

18. Two block of masses m_1 and m_2 connected by a light spring rest on a horizontal plane. The coefficient of friction between

the block and the surface is equal to μ . What minimum constant force has to be applied in the horizontal direction to the block of mass m_1 in order to shift the other block?

- A. 8 N
- B. 15 N
- C. 10 N
- D. 25 N

Answer: A

 [Watch Video Solution](#)

19. A block of mass m is attached with a massless spring of force constant k . The block is placed over a rough inclined surface for which the coefficient of friction is $\mu = \frac{3}{4}$. The minimum value of

M required to move the block up the plane is (Neglect mass of string, mass of pulley and friction in pulley)

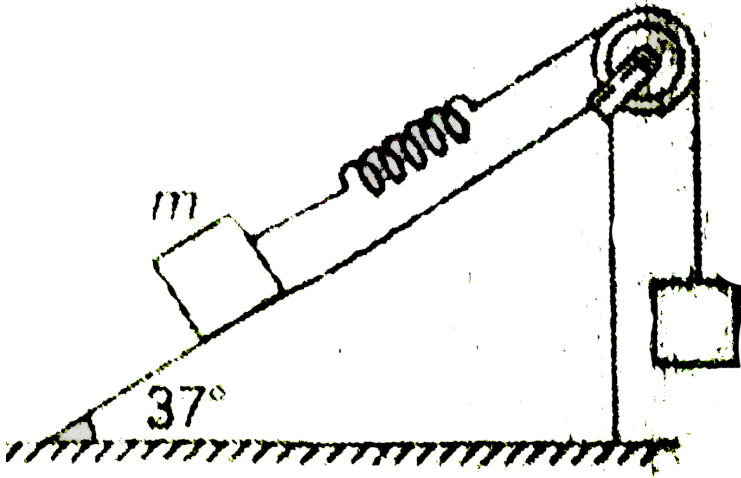

A. $\frac{3}{5}m$

B. $\frac{4}{5}m$

C. $\frac{6}{5}m$

D. $\frac{3}{2}m$

Answer: A



Watch Video Solution

20. The potential energy of a particle of mass m is given by

$U = \frac{1}{2}kx^2$ for $x < 0$ and $U = 0$ for $x \geq 0$. If total mechanical

energy of the particle is E . Then its speed at $x = \sqrt{\frac{2E}{k}}$ is

A. zero

B. $\sqrt{\frac{2E}{m}}$

C. $\sqrt{\frac{E}{m}}$

D. $\sqrt{\frac{E}{2m}}$

Answer: B



Watch Video Solution

21. A body of mass 2 kg is moved from a point A to a point B by

an external agent in a conservative force field. If the velocity of

the body at the points A and B are $5m/s$ and $3m/s$ respectively and the work done by the external agent is -10 J , then the change in potential energy between point A and B is

A. 6 J

B. 36 J

C. 16 J

D. None of these

Answer: A



Watch Video Solution

22. A block of mass $m = 0.1\text{ kg}$ is released from a height of 4 m on a curved smooth surface. On the horizontal surface, path AB is smooth and path BC offers coefficient of friction $\mu = 0.1$. If the

impact of block with the vertical wall at C be elastic, the total distance covered by the block on the horizontal surface before coming to rest will be (take $g = 10\text{ m/s}^2$)

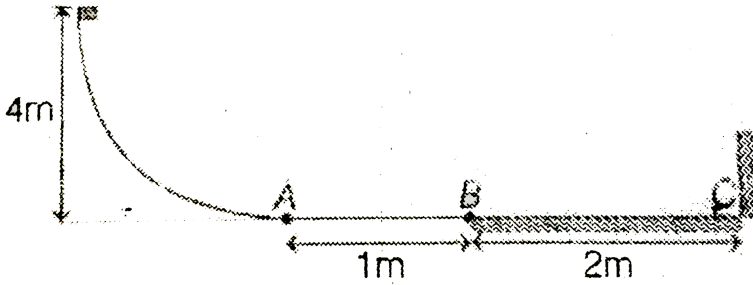

- A. 29 m
- B. 49 m
- C. 59 m
- D. 109 m

Answer: C



[View Text Solution](#)

23. A system consists of two cubes of mass m_1 , and m_2 respectively connected by a spring of force constant k . force (F) that should be applied to the upper cube for which the lower

one just lifts after the force is removed, is

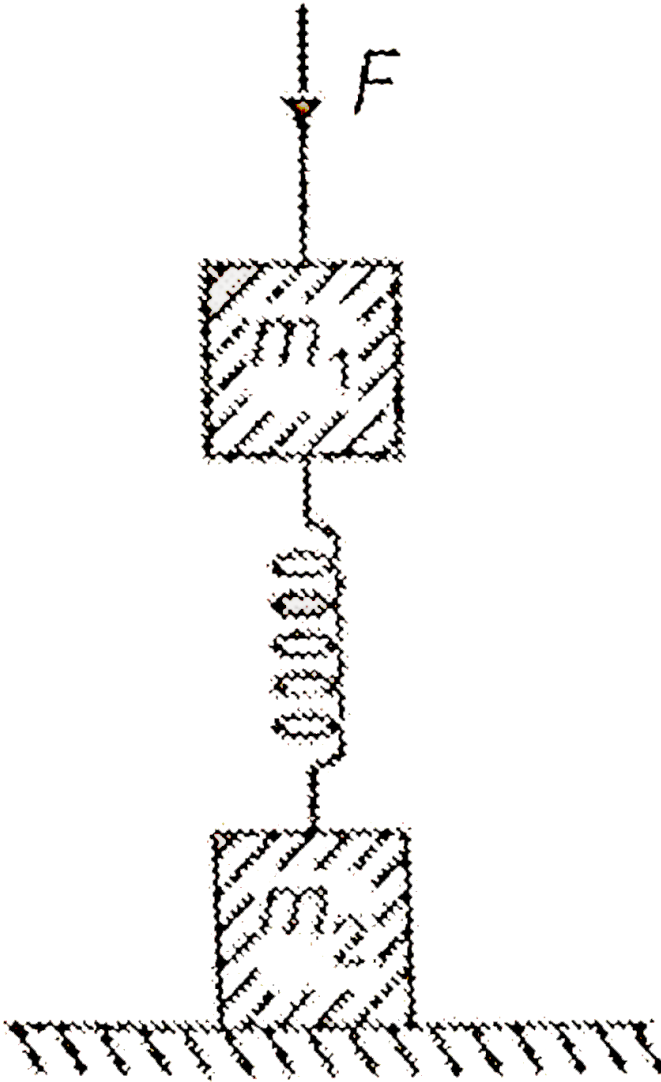

A. mg

B. $\frac{m_1 m_2}{m_1 + m_2} g$

C. $(m_1 + m_2)g$

D. m_2g

Answer: C



Watch Video Solution

24. A block mass $m = 2\text{kg}$ is moving with velocity v_0 towards a mass less unstretched spring of the force constant $k = 10\text{N/m}$. Coefficient of friction between the block and the ground is $\mu = 0.2$. Find the maximum value of v_0 so that after pressing the spring the block does not return back but stops

there permanently.

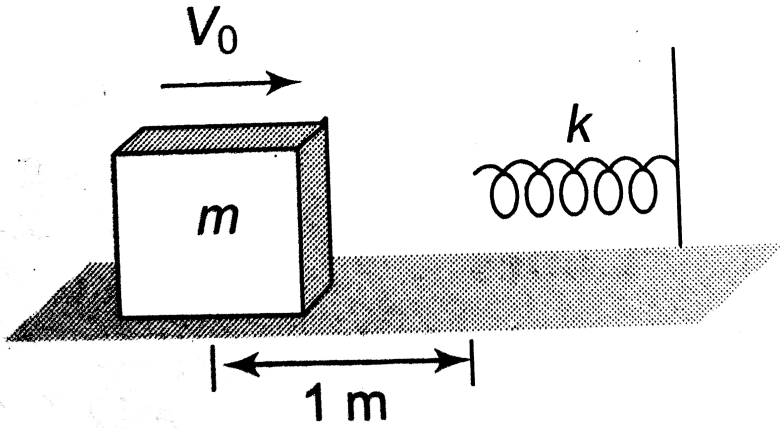

- A. $\sqrt{12}m / s$
- B. $\sqrt{4.2}m / s$
- C. $\sqrt{10}m / s$
- D. $\sqrt{6.4}m / s$

Answer: D



Watch Video Solution

25. In a projectile motion, if we plot a graph between power of the force acting on the projectile and time, then it would be like

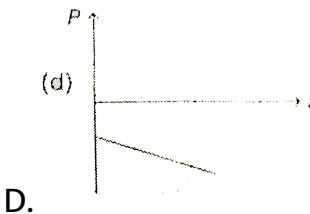
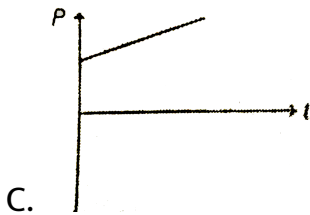
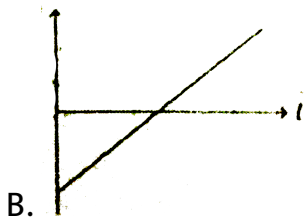
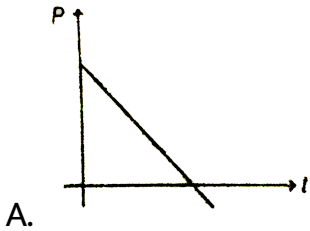

Answer: B



26. Potential energy of a particle moving along x-axis under the action of only conservative force is given as $U = 10 + 4 \cos(4\pi x)$. Here, U is in Joule and x in metres. Total mechanical energy of the particle is 16 J. Choose the correct option.

- A. At $x = 1.25$ m, particle is at equilibrium position
- B. Maximum kinetic energy of the particle is 20 J
- C. Both (a) and (b) are correct
- D. Both (a) and (b) are wrong

Answer: A

27. Acceleration of a particle moving in $x - y$ plane varies with time t as. $\vec{a} = (ti + 3t^2j)$.

Here a is in m/s^2 and t in sec. At time $t = 0$ particle is at rest origin. Mass of the particles is $1kg$. Find the net work done on the particle in first 2 sec.

A. 40 J

B. 34 J

C. 16 J

D. 48 J

Answer: B



Watch Video Solution

28. A small mass slides down an inclined plane of inclination θ with the horizontal. The co-efficient of friction is $\mu = \mu_0 x$ where x is the distance through which the mass slides down and μ_0 a constant. Then, the distance covered by the mass before it stops is

A. $\frac{2}{\mu_0} \tan \theta$

B. $\frac{4}{\mu_0} \tan \theta$

C. $\frac{1}{2\mu_0} \tan \theta$

D. $\frac{1}{\mu_0} \tan \theta$

Answer: A



Watch Video Solution

29. Figure, a block slides along a track from one level to a higher level by moving through an intermediate valley. The track is friction less until the block reaches the higher

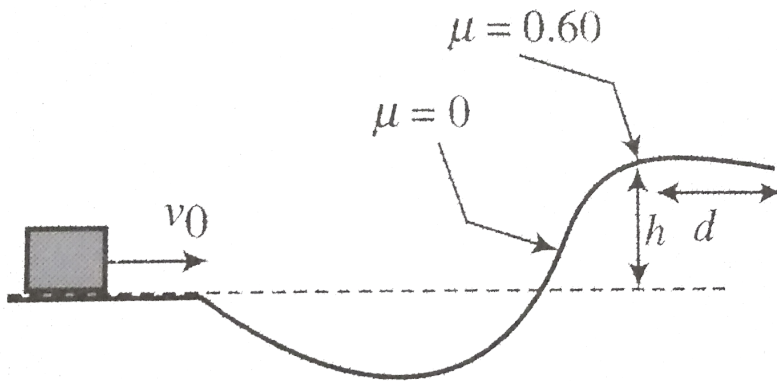

level. Then

there is friction force which stops the block at a distance d . The block's initial speed v_0 is 6.0m/s^{-1} , the height difference h is 1.1m , and the coefficient of kinetic friction μ is 0.60 . Find d .

- A. 1.17 m
- B. 1.71 m
- C. 3.41 m
- D. 2.81 m

Answer: A

 Watch Video Solution

30. In the figure the variation of components of acceleration of a particle of mass is 1kg is shown w.r.t. time. The initial velocity of the particle is $\vec{u} = (-3i + 4j)\text{m/s}$. The total work done by the resultant force on the particle in time from $t = 0$ to $t = 4$ seconds is :

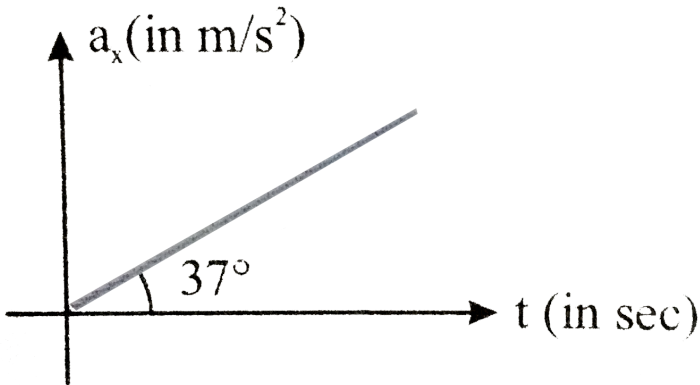

A. 15 J

B. 10 J

C. 0

D. 20 J

Answer: B



Watch Video Solution

31. A block attached to a spring, pulled by a constant horizontal force, is kept on a smooth surface as shown in figure. Initially, the spring is in the natural length state. Then the maximum positive work that the applied force F can do is (give that string

does not break)

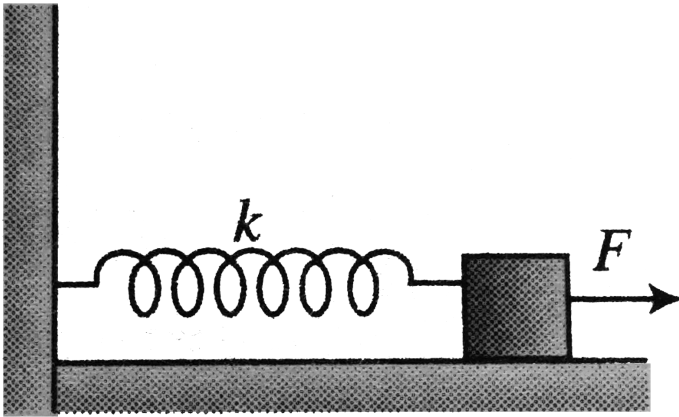

- A. $\frac{F^2}{k}$
- B. $\frac{2F^2}{k}$
- C. $\frac{4F^2}{k}$
- D. $\frac{F^2}{2k}$

Answer: d



Watch Video Solution

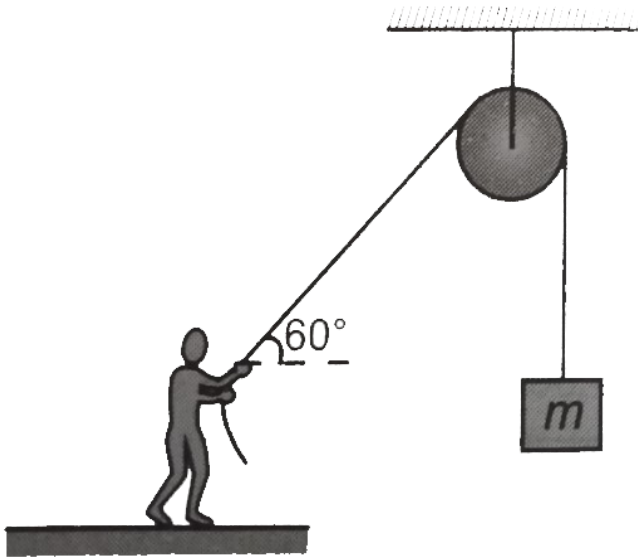

32.

A man is supplying a constant power of $500 \frac{J}{s}$ to a massless string by pulling it at a constant speed of $10 \frac{m}{s}$ as shown. It is known that kinetic energy of the block is increasing at a rate of $100 \frac{J}{s}$. Then the mass of the block is:

- A. 5 kg
- B. 3 kg
- C. 10 kg
- D. 4 kg

Answer: D

 Watch Video Solution

33. In the figure shown all the surfaces are frictionless and mass of block $m = 1\text{kg}$, block and wedge are held initially at rest, now wedge is given a horizontal acceleration of 10m/s^2 by applying a force on the wedge so that the block does not slip on the wedge, the work done by normal force in ground frame on the block in $\sqrt{3}$ sec is

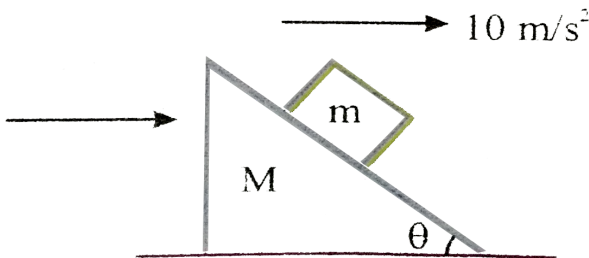

A. 100 J

B. 200 J

C. 150 J

D. $100\sqrt{3}J$

Answer: C



Watch Video Solution

34. As shown in the figure a block of mass 'm' is placed on a smooth wedge moving with constant acceleration such that block does not move with respect to the wedge. Find work done

by the net force on the block in time t . (Initial speed is 0)

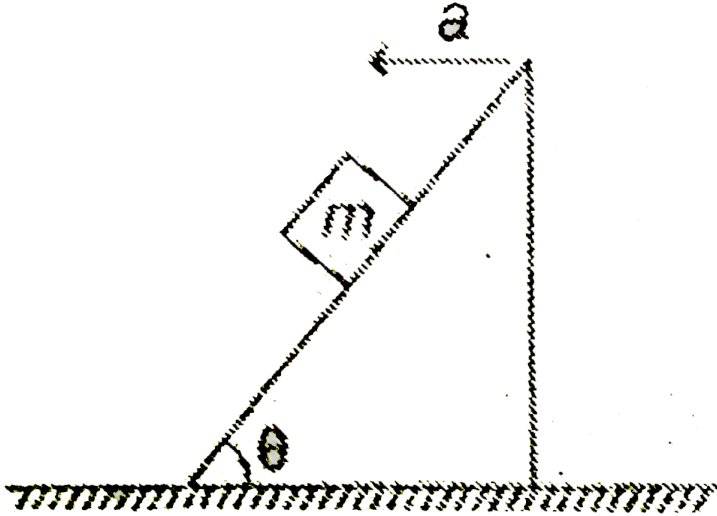

- A. $m(gt \tan \theta)^2$
- B. $\frac{m}{3}(gt \tan \theta)^2$
- C. $\frac{4}{9}m(gt \tan \theta)^2$
- D. $\frac{m}{2}(gt \tan \theta)^2$

Answer: D



Watch Video Solution

35. A body is moving up an inclined plane of angle θ with an initial kinetic energy E . The coefficient of friction between the plane and body is μ . The work done against friction before the body comes to rest is

A. $\frac{\mu E \cos \theta}{\cos \theta + \sin \theta}$

B. E

C. $\frac{\mu E \cos \theta}{\mu \cos \theta - \sin \theta}$

D. $\frac{\mu E \cos \theta}{\mu \cos \theta + \sin \theta}$

Answer: D



Watch Video Solution

36. Three components of a force acting on a particle are varying according to the graphs as shown. To reach at point B(8, 20, 0)m from point A(0, 5, 12)m the particle moves on paths parallel to x-axis then y-axis and then z-axis, then work done by this force is:

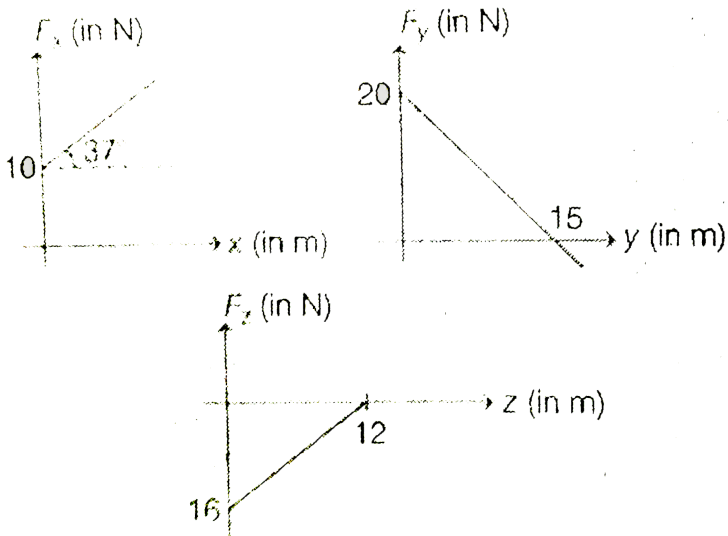

- A. 192 J
- B. 58 J
- C. 250 J
- D. 125 J

Answer: C



Watch Video Solution

37. A floor-mat of mass M made up of extensible material, is rolled along its length so as to form a cylinder of radius R and kept on a rough horizontal surface. If the mat is now unrolled, without sliding, to a radius $\frac{R}{2}$, the decrease in potential energy is

A. $\frac{2}{5}MgR$

B. $\frac{5}{7}MgR$

C. $\frac{7}{8}MgR$

D. MgR

Answer: C

38. A block of mass m is attached to a frame by a light spring of force constant k . The frame and block are initially at rest with $x = x_0$, the natural length of the spring. If the frame is given a constant horizontal acceleration a_0 towards left, determine the maximum velocity of the block relative to the frame (block is free to move inside frame). Ignore any friction.

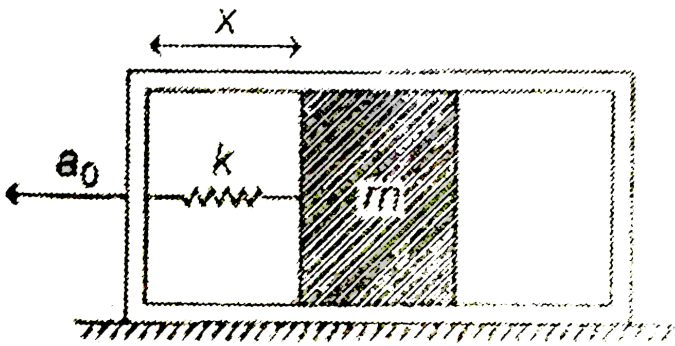

- A. $a_0 \sqrt{\frac{m}{2k}}$
 B. $a_0 \sqrt{\frac{2m}{k}}$
 C. $a_0 \sqrt{\frac{m}{k}}$

D. $\frac{1}{2}a_0\sqrt{\frac{m}{k}}$

Answer: C



Watch Video Solution

39. Figure shows two small blocks placed on smooth horizontal surface. They start moving from the same line with forces $2F$ and F respectively acting on the blocks. Their momenta and kinetic energies at the instant of crossing the finishing line as shown in

figure are P_A , P_B and K_A , K_B . Then choose the correct option.

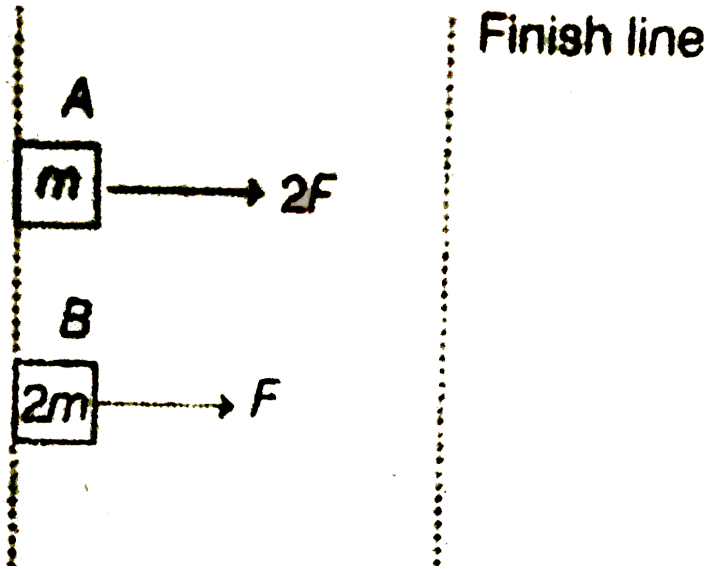

- A. $K_A = K_B, P_A = P_B$
- B. $K_A > K_B, P_A > P_B$
- C. $K_A > K_B, P_A < P_B$
- D. $K_A > K_B, P_A = P_B$

Answer: D



Watch Video Solution

40. Inside a smooth hemispherical cavity, a particle P can slide freely. The block having this cavity is moving with constant acceleration $a = g$ (where g is acceleration due to gravity). The particle is released from the state of rest from the topmost position of the surface of the cavity as shown. The angle θ with the vertical, when the particle will have maximum velocity with respect to the block is

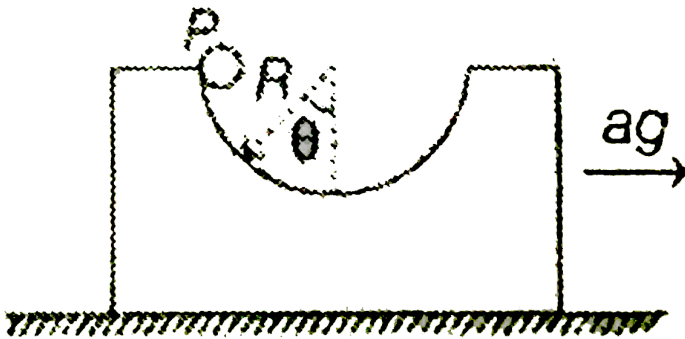

- A. 45°
- B. 60°
- C. 30°

D. 0°

Answer: A

 Watch Video Solution

41. A block of mass M slides along a horizontal table with speed v_0 . At $x = 0$, it hits a spring with spring constant k and begins to experience a friction force. The coefficient of friction is variable and is given by $\mu = bx$, where b is a positive constant. Find the loss in mechanical energy when the block has first come momentarily to rest.

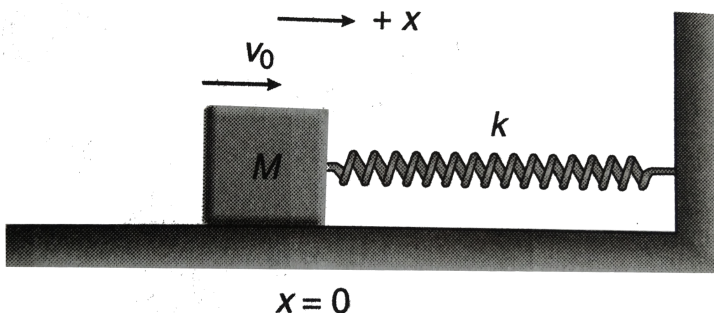

A. $\frac{gbMv_0^2}{2k}$

B. $\frac{Mgbv_0^2}{2(k + gb)}$

C. $\frac{gbMv_0^2}{k}$

D. $\frac{M^2gbv_0^2}{2(k + Mgb)}$

Answer: D



Watch Video Solution

42. A ball of mass m is thrown upward with a velocity v . If air exerts an average resisting force F , the velocity with which the ball returns to the thrower is

A. $v\sqrt{\frac{mg}{mg + F}}$

B. $v\sqrt{\frac{F}{mg + F}}$

C. $v \sqrt{\frac{mg - F}{mg + F}}$

D. None of these

Answer: C



Watch Video Solution

B More Than One Option Is Correct

1. If the kinetic energy of a body is directly proportional to time t , the magnitude of the force acting on the body is

- A. directly proportional to \sqrt{t}
- B. inversely proportional to \sqrt{t}
- C. directly proportional to the speed of the body
- D. inversely proportional to the speed of the body

Answer: B::D



Watch Video Solution

2. Select the correct alternative(s).

A. Work done by static friction is always zero

B. Work done by kinetic friction can be positive also

C. Kinetic energy of a system can not be increased without applying any external force on the system

D. Work energy theorem is valid in non-inertial frames also

Answer: B::D



Watch Video Solution

3. Work done by a force on an object is zero, if

A. the force is always perpendicular to its acceleration

B. the object is stationary but the point of application of the force moves on the object

C. the force is always perpendicular to its velocity

D. the object moves in such a way that the point of application of the force remains fixed

Answer: B::C::D



[Watch Video Solution](#)

4. A block of mass 2 kg is hanging over a smooth and light pulley through a light string. The other end of the string is pulled by a

constant force $F = 40 \text{ N}$. The kinetic energy of the particle increases 40 J in a given interval of time. Then, ($g = 10 \text{ m/s}^2$)

A. tension in the string is 40 N

B. displacement of the block in the given interval of time is 2 m

C. work done by gravity is -20 J

D. work done by tension is 80 J

Answer: A::B::D



Watch Video Solution

5. A particle moves in a straight line with constant acceleration under a constant force F . Select the correct alternative(s).

A. Power developed by this force varies linearly with time

B. Power developed by this force varies parabolically with time

C. Power developed by this force varies linearly with displacement

D. Power developed by this force varies parabolically with displacement

Answer: A::D

 [Watch Video Solution](#)

6. One end of a light spring of spring constant k is fixed to a wall and the other end is tied to a block placed on a smooth horizontal surface. In a displacement, the work done by the spring is $+\left(\frac{1}{2}\right)kx^2$. The possible cases are.

- A. the spring was initially stretched by a distance x and finally was in its natural length
- B. the spring was initially in its natural length and finally it was compressed by a distance x
- C. the spring was initially compressed by a distance x and finally was in its natural length
- D. the spring was initially in its natural length and finally stretched by a distance x

Answer: A::C



Watch Video Solution

7. A block is suspended by an ideal spring of force constant force F and if maximum displacement of block from its initial mean

position of rest is x_0 then

A. increase in energy stored in spring is kx_0^2

B. $x_0 = \frac{3F}{2k}$

C. $x_0 = \frac{2F}{k}$

D. work done by applied force F is Fx_0

Answer: C::D



Watch Video Solution

8. The potential energy U in joule of a particle of mass $1kg$ moving in $x - y$ plane obeys the law $U = 3x + 4y$, where (x, y) are the co-ordinates of the particle in metre. If the particle is at rest at $(6, 4)$ at time $t = 0$ then :

A. the particle has constant acceleration

B. the particle has zero acceleration

C. the speed of particle when it crosses the y-axis is 10m/s

D. co-ordinates of particle at $t = 1\text{ s}$ are $(4, 5, 2)$

Answer: A::C::D



Watch Video Solution

9. In a projectile motion, power of the gravitational force

A. is constant throughout

B. is negative for first half, zero at topmost point and positive for rest half

C. varies linearly with time

D. is positive for complete path

Answer: B::C

 Watch Video Solution

10. Displacement time graph of a particle moving in a straight line is as shown in figure. Select the correct alternative (s) :

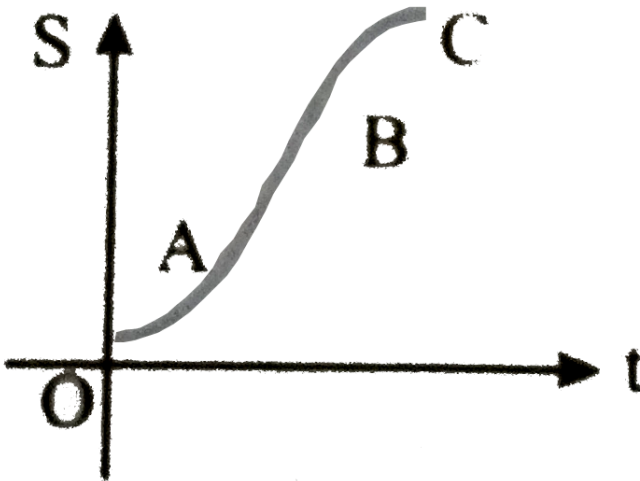

- A. Work done by all the forces in region OA and BC is positive
- B. Work done by all the forces in region AB is zero

C. Work done by all the forces in region BC is negative

D. Work done by all forces in region OA is negative

Answer: B::C



Watch Video Solution

11. A smooth track in the form of a quarter circle of radius $6m$ lies in the vertical plane. A particle moves from P_1 to P_2 under the action of forces \vec{F}_1 , \vec{F}_2 and \vec{F}_3 . Force \vec{F}_1 is always $30N$ in magnitude. Force \vec{F}_3 always acts tangentially to the track and

is of magnitude 15N . Select the correct alternative (s) :

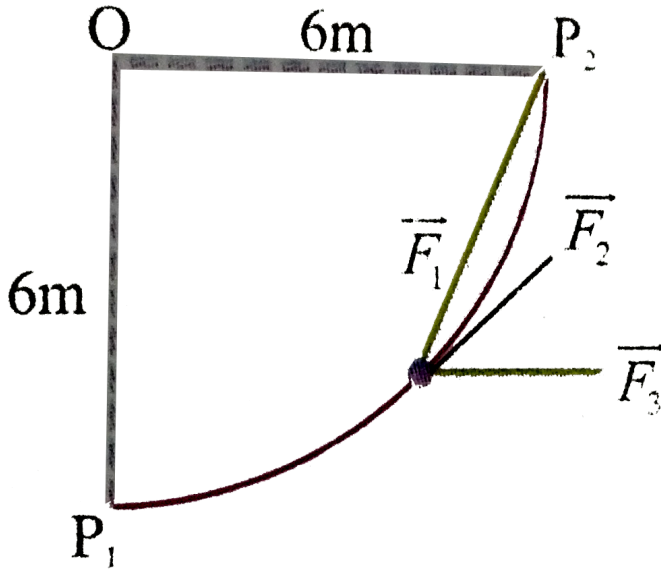

- A. Work done by F_1 is 120 J
- B. Work done by F_2 is 180 J
- C. Work done by F_3 is 45π
- D. F_1 is conservative in nature

Answer: B::C::D



Watch Video Solution

12. A particle is acted upon by only a conservative force $F = (7\hat{i} - 6\hat{j})$ N (no other force is acting on the particle).

Under the influence of this force particle moves from $(0, 0)$ to $(-3\text{m}, 4\text{m})$ then

- A. work done by the force is 3 J
- B. work done by the force is -45J
- C. at $(0, 0)$ speed of the particle must be zero
- D. at $(0, 0)$ speed of the particle must not be zero

Answer: B::D



[Watch Video Solution](#)

13. A block of mass M_1 is attached with a spring constant k . The whole arrangement is placed on a vehicle as shown in the figure.

If the vehicle starts moving towards right with an acceleration a

(there is no friction anywhere), then :

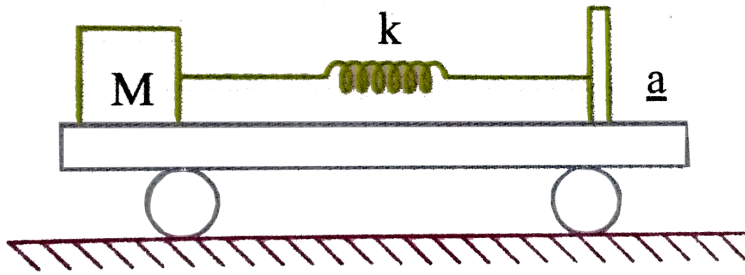

- A. maximum elongation in the spring is $\frac{Ma}{k}$
- B. maximum elongation in the spring is $\frac{2Ma}{k}$
- C. maximum compression in the spring is $\frac{2Ma}{k}$
- D. maximum compression in the spring is zero

Answer: B::D



Watch Video Solution

14. Two blocks A and B having different kinetic energies K_A and $K_B (> K_A)$ are released on rough horizontal ground.

Coefficient of friction for both of them is same. Then

- A. momentum of B is greater than momentum of A
- B. more work has to be done by friction to stop B
- C. B will travel more distance before stopping
- D. from the given data we can not compare the distance travelled by them before stopping

Answer: B::D



Watch Video Solution

15. A force $F = -kx^3$ is acting on a block moving along x-axis.

Here, k is a positive constant. Work done by this force is

- A. positive in displacing the block from $x = 3$ to $x = 1$
- B. positive in displacing the block from $x = -1$ to $x = -3$
- C. negative in displacing the block from $x = 3$ to $x = 1$
- D. negative in displacing the block from $x = -1$ to $x = -3$

Answer: A::D



[Watch Video Solution](#)

16. Power of a force acting on a block varies with time t as shown in figure. Then, angle between force acting on the block and its

velocity is

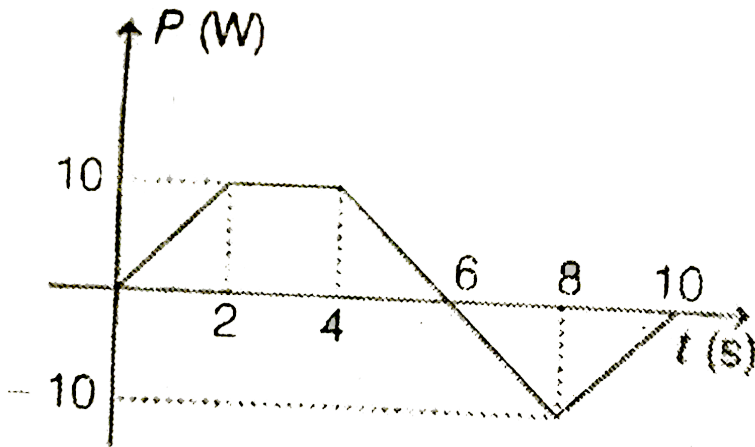

A. acute at $t = 1$ s

B. 90° at $t = 3$ s

C. obtuse at $t = 7$ s

D. change in kinetic energy from $t = 0$, to $t = 10$ s is 20 J

Answer: A::C::D



Watch Video Solution

17. Displacement time graph of a particle moving in a straight line is as shown in figure.

From the graph we can conclude that work done on the block is :

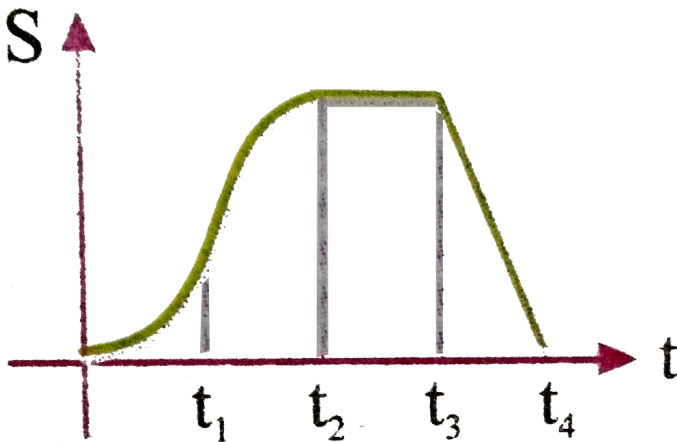

- A. positive from 0 to t_1
- B. negative from t_1 to t_2
- C. zero from t_2 to t_3
- D. negative from t_3 to t_4

Answer: A::B::C



Watch Video Solution

18. In the pulley-block system shown in figure, strings are light. Pulleys are massless and smooth. System is released from rest. In 0.3 seconds.

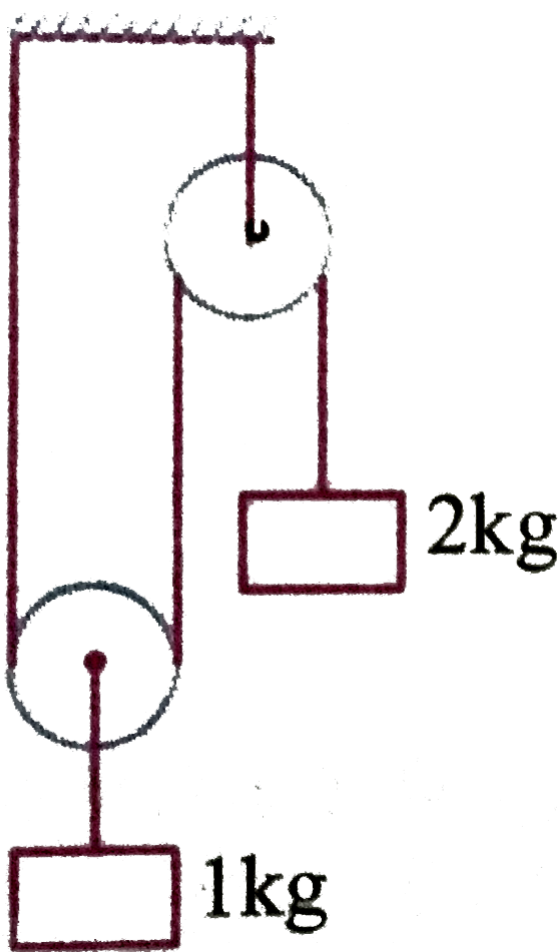

- (a) work done on 2kg block by gravity is $6J$
- (b) work done on 2kg block by string is $-2J$
- (c) work done on 1kg block by gravity is $-1.5J$
- (d) work done on 1kg block string is $2J$.

A. work done on 2 kg block by gravity is $6 J$

B. work done on 2 kg block by string is $-2J$

C. work done on 1 kg block by gravity is $1.5J$

D. work done on 1 kg block by string is 2 J

Answer: A::B::C::D



Watch Video Solution

19. A particle is acted upon by a force of constant magnitude which is always perpendicular to the velocity of the particle. The motion of the particle takes place in a plane. It follows that

A. its velocity is constant

B. its acceleration is constant

C. its kinetic energy is constant

D. it move in a circular path

Answer: C::D

 Watch Video Solution

20. A block slides down a smooth inclined plane and then moves on to a rough horizontal surface. Which of the following is/are correct? (Neglect impulsive effect at the bottom of incline)

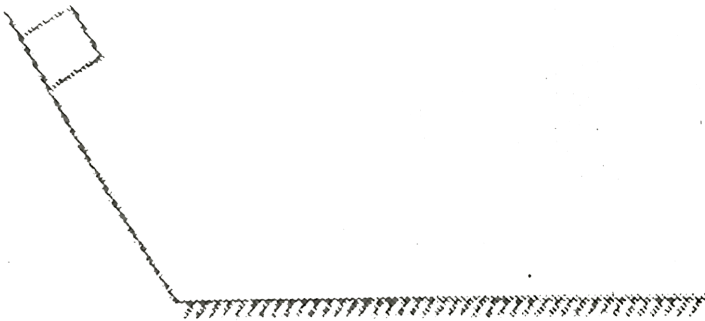

A. The graph of velocity as a function of time is

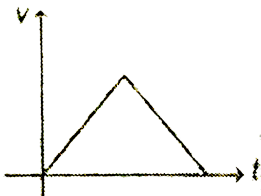

B. The graph of acceleration as a function of time is

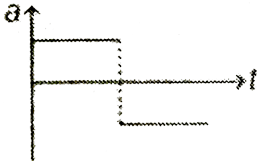

C. The graph of mechanical energy as a function of time is

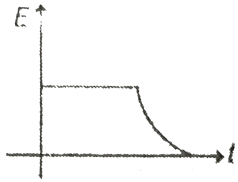

D. The graph of kinetic energy as a function of time is

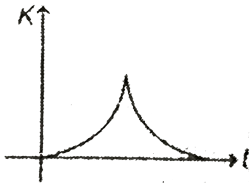

Answer: A::B::C::D

 [Watch Video Solution](#)

21. A block of mass m is pulled by a force of constant power P placed on a rough horizontal plane. The friction coefficient between the block and the surface is μ . Then

A. The maximum velocity of the block during the motion is

$$\frac{P}{\mu mg}$$

B. The maximum velocity of the block during the motion is

$$\frac{P}{2\mu mg}$$

C. The block's speed is never decreasing and finally becomes constant

D. The speed of the block first increases to a maximum value and then decreases

Answer: A::C



Watch Video Solution

22. A force of constant magnitude F_0 is applied in the tangential direction as shown in the figure. Assume that the bob is at its lowest point initially.

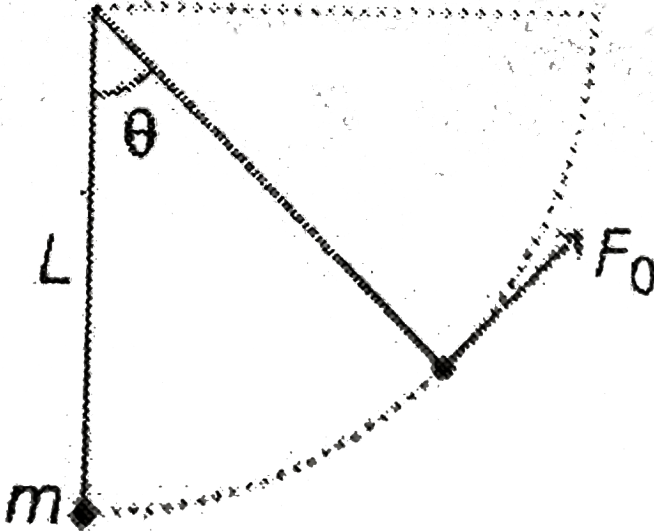

- A. Speed of bob at $\theta = 60^\circ$ is $\sqrt{\frac{2L}{m} \left[\frac{F_0\pi}{3} + \frac{mg}{2} \right]}$
- B. Speed of bob at $\theta = 60^\circ$ is $\sqrt{\frac{2L}{m} \left[\frac{F_0\pi}{3} - \frac{mg}{2} \right]}$
- C. Tension in thread at $\theta = 60^\circ$ is $\left[\frac{2F_0\pi}{3} - \frac{mg}{2} \right]$
- D. Tension in thread at $\theta = 60^\circ$ is $\left[\frac{2F_0\pi}{3} + \frac{mg}{2} \right]$

Answer: B::C



[View Text Solution](#)

23. A bead slides on a fixed frictionless wire bent into a horizontal semicircle of radius R_0 as shown in figure. In addition to any normal forces exerted by the wire, the bead is subjected to an external force that points directly away from origin and depends on distance r from the origin according to the formula

$$F = F_0 \left(\frac{r}{R_0} \right)^2 \hat{r}$$

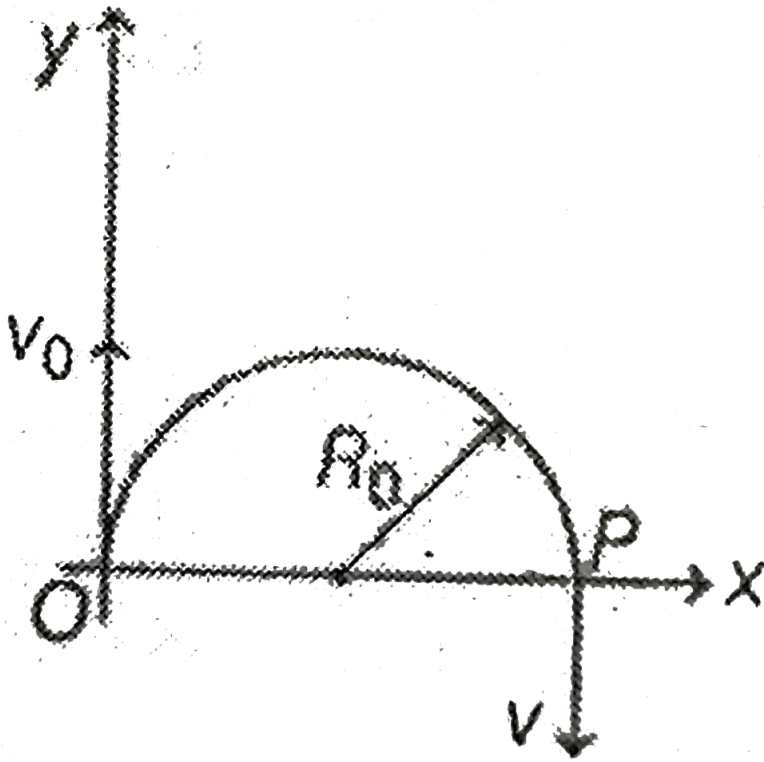

A. Given force is a central force

B. Given force is a conservation force

C. Work done by external force as bead leaves the track

(starting from origin) is $\frac{8F_0 R_0}{3}$

D. Speed v of bead as it leaves the wire at P is

$$\sqrt{v_0^2 + \frac{18F_0 R_0}{3m}}$$

Answer: A::B::C



[View Text Solution](#)

24. A block of mass m is placed on a circular track and then it is given a velocity v vertically downwards at position A on track. If block moves on track with constant speed, then

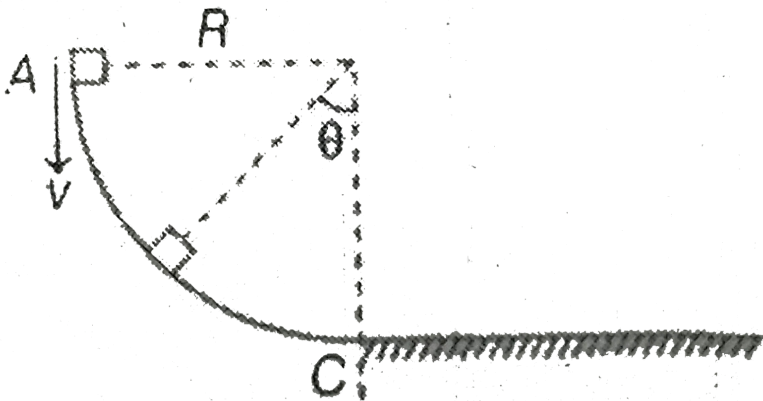

A. Coefficient of friction between block and circular track as

function of angle θ is
$$\mu = \frac{\sin \theta}{\cot \theta + \frac{v^2}{Rg}}$$

B. Coefficient of friction between block and circular track as

function of angle θ is
$$\mu = \frac{\sin \theta}{\cos \theta + \frac{v^2}{Rg}}$$

C. Instantaneous power due to friction is $-mgv \sin \theta$

D. Work done from A to C by friction on block will be $-mgR$

Answer: B::C::D



[View Text Solution](#)

25. In the system as shown in figure, the blocks have masses m_1 and m_2 , the spring constant is k , coefficient of friction between the block of mass m_1 and the surface is μ . The system is released with zero initial speed from the position where the

spring is in its natural length.

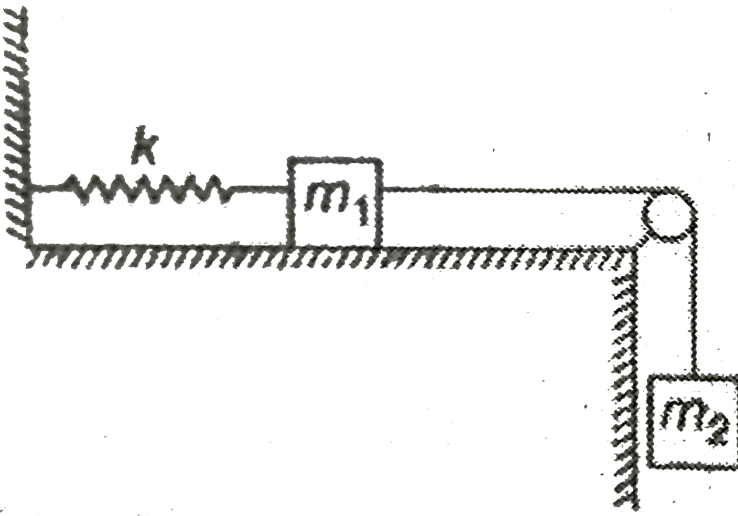

A. The maximum possible speed of the blocks is

$$\frac{g(m_2 - \mu m_1)}{\sqrt{k(m_1 + m_2)}}$$

B. The maximum possible speed of the blocks is

$$\frac{g(\mu m_1)}{\sqrt{k(m_1 + m_2)}}$$

C. The maximum possible speed of the blocks if friction is

absent is
$$\frac{gm_2}{\sqrt{k(m_1 + m_2)}}$$

D. The maximum possible speed of the blocks if friction is

absent is $\frac{gm_1}{\sqrt{k(m_1 + m_2)}}$

Answer: A::C



[View Text Solution](#)

26. Instantaneous power delivered by engine of a car of mass 18 kg moving on +x-axis is given as $p = (2x + 5)$ watt, where x is (in meter) position of car. Car starts from origin from rest (choose the correct statement(s)).

- A. Power increases with time.
- B. Power decreases with time.
- C. At $x = 1\text{m}$, speed of car is $v = 1\text{m} / \text{s}$
- D. At $x = 1\text{m}$, speed of car is $v = 2\text{m} / \text{s}$

Answer: A::C

 [View Text Solution](#)

C Comprehension Type Questions

1. A ball is released from point A as shown in figure. The ball leaves the track at B. All surfaces are smooth.

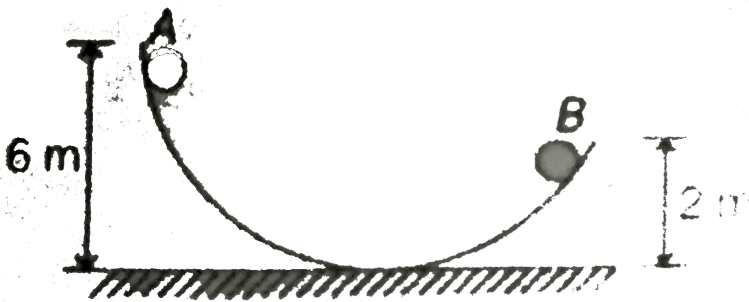

Let h be the maximum height from ground reached by ball after leaving track at B. Then,

A. $h = 6 \text{ m}$

B. $h < 6m$

C. $h > 6m$

D. speed of ball at B will change if shape of track is changed

keeping h_A and h_B constant

Answer: B

 [Watch Video Solution](#)

2. A ball is released from point A as shown in figure. The ball leaves the track at B. All surfaces are smooth.

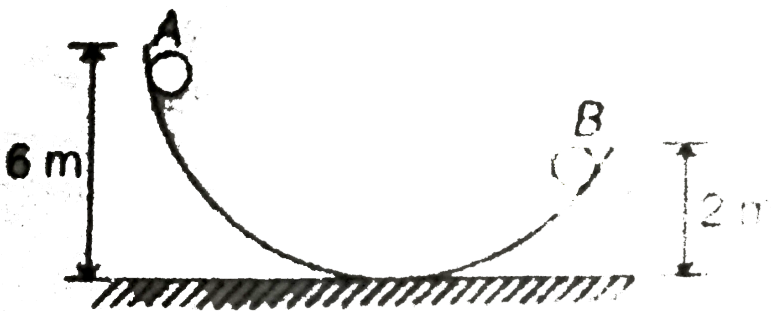

If track makes an angle 30° with horizontal at B, then maximum height attained by ball will be

- A. 3 m
- B. 4 m
- C. 4.5 m
- D. 5 m

Answer: A



[Watch Video Solution](#)

3. In the figure shown, upper block is given a velocity of $6m/s$ and lower block. $3m/s$. When relative motion between them is

stopped

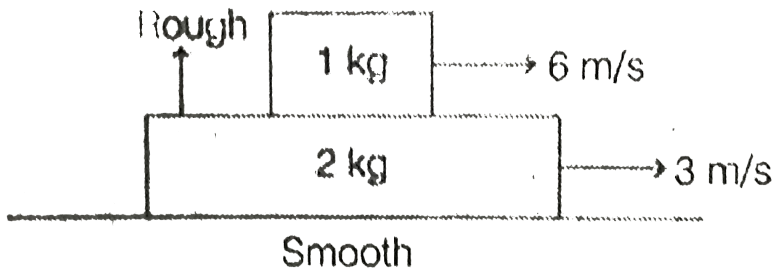

- A. Work done by friction on upper block is negative
- B. Work done by friction on both the blocks is negative
- C. Work done by friction on lower block is negative
- D. Work done by friction on both the blocks is positive

Answer: A

 [Watch Video Solution](#)

4. In the figure shown, upper block is given a velocity of $6m/s$ and lower block. $3m/s$. When relative motion between them is

stopped

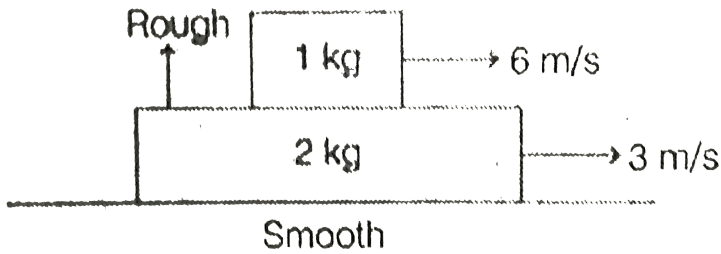

- A. Work done by friction on upper block is $-10J$
- B. Work done by friction on lower block $+10J$
- C. Net work done by friction is zero
- D. All of the above

Answer: A

 [Watch Video Solution](#)

5. A ball is released from the bottom of a tank filled with water up to 2m. On reaching the top its kinetic energy is found to be

16 J. Mass of the ball is 2 kg.

Ignoring the viscosity, let W_1 be the work done by upthrust and W_2 the work done by gravity, then ($g = 10 \text{ m/s}^2$)

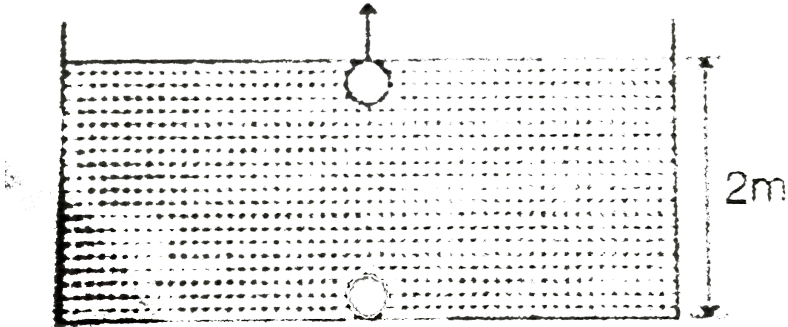

- A. $W_1 = 32J, W_2 = -16J$
- B. $W_1 = -16J, W_2 = 32J$
- C. $W_1 = -56J, W_2 = -40J$
- D. $W_1 = -40J, W_2 = -24J$

Answer: C



Watch Video Solution

6. A ball is released from the bottom of a tank filled with water up to 2m. On reaching the top its kinetic energy is found to be 16 J. Mass of the ball is 2 kg.

Density of the ball in $\frac{kg}{m^3}$ is

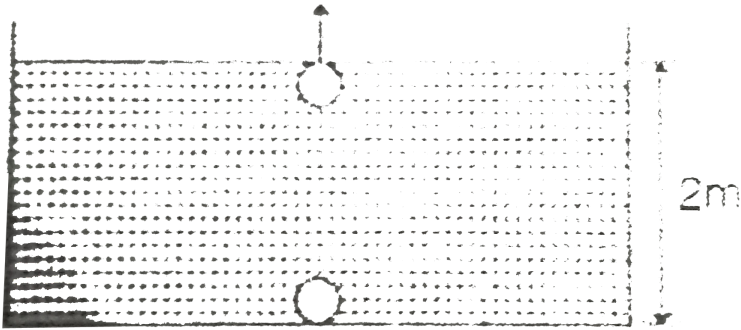

- A. $\frac{5}{7} \times 10^3$
- B. $\frac{3}{4} \times 10^3$
- C. $\frac{2}{3} \times 10^3$
- D. $\frac{1}{3} \times 10^3$

Answer: A



7. The system is released from rest with both the springs in unstretched positions. Mass of each block is 1 kg and force constant of each spring is $10\text{N}/\text{m}$.

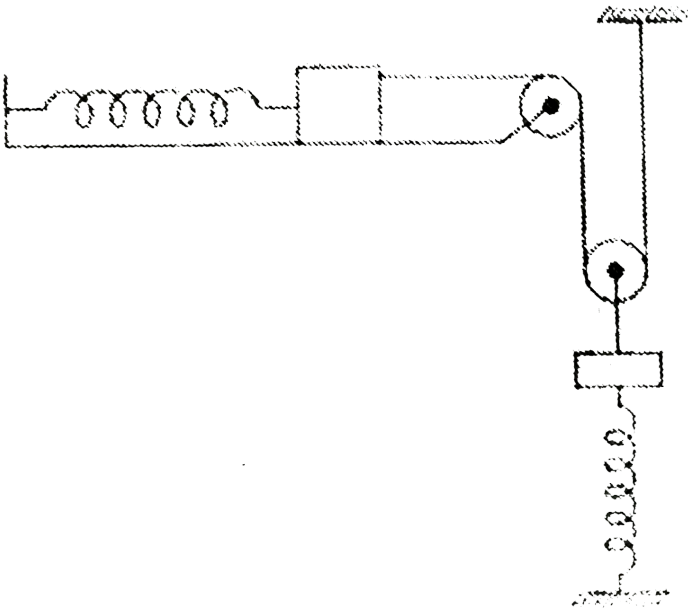

Extension of horizontal spring in equilibrium is

A. 0.2 m

B. 0.4 m

C. 0.6 m

D. 0.8 m

Answer: B



Watch Video Solution

8. The system is released from rest with both the springs in unstretched positions. Mass of each block is 1 kg and force constant of each spring is $10N/m$.

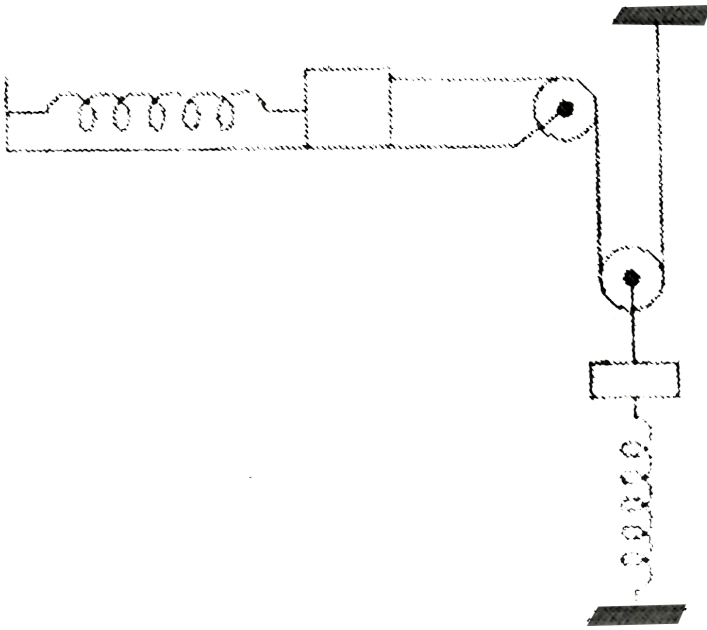

In the equilibrium position, speed of the block placed horizontally is

- A. 3.21m / s
- B. 2.21m / s
- C. 1.93m / s
- D. 1.26m / s

Answer: D



9. In a conservative force field we can find the radial component of force from the potential energy function by using $F = -\frac{dU}{dr}$. Here, a positive force means repulsion and a negative force means attraction. From the given potential energy function $U(r)$ we can find the equilibrium position where force is zero. We can also find the ionisation energy which is the work done to move the particle from a certain position to infinity.

Let us consider a case in which a particle is bound to a certain point at a distance r from the centre of the force. The potential energy of the particle is : $U(r) = \frac{A}{r^2} - \frac{B}{r}$ where r is the distance from the centre of the force and A and B are positive constants. Answer the following questions.

The equilibrium distance is given by

A. $\frac{A}{B}$

B. $\frac{2A}{B}$

C. $\frac{3A}{B}$

D. $\frac{B}{2A}$

Answer: B



Watch Video Solution

10. In a conservative force field we can find the radial component of force from the potential energy function by using $F = -\frac{dU}{dr}$. Here, a positive force means repulsion and a negative force means attraction. From the given potential energy function $U(r)$ we can find the equilibrium position where force is zero. We can also find the ionisation energy which is the work done to move the particle from a certain position to

infinity.

Let us consider a case in which a particle is bound to a certain point at a distance r from the centre of the force. The potential energy of the particle is : $U(r) = \frac{A}{r^2} - \frac{B}{r}$ where r is the distance from the centre of the force and A and B are positive constants. Answer the following questions.

The equilibrium is

- A. stable
- B. unstable
- C. neutral
- D. cannot be predicted

Answer: A



[Watch Video Solution](#)

11. In a conservative force field we can find the radial component of force from the potential energy function by using $F = - \frac{dU}{dr}$. Here, a positive force means repulsion and a negative force means attraction. From the given potential energy function $U(r)$ we can find the equilibrium position where force is zero. We can also find the ionisation energy which is the work done to move the particle from a certain position to infinity.

Let us consider a case in which a particle is bound to a certain point at a distance r from the centre of the force. The potential energy of the particle is : $U(r) = \frac{A}{r^2} - \frac{B}{r}$ where r is the distance from the centre of the force and A and B are positive constants. Answer the following questions.

The work required to move the particle from equilibrium distance to infinity is

A. $\frac{B}{4A}$

B. $\frac{4B}{A}$

C. $\frac{B^2}{4A}$

D. $\frac{4B^2}{A}$

Answer: C



Watch Video Solution

12. In a conservative force field we can find the radial component of force from the potential energy function by using $F = -\frac{dU}{dr}$. Here, a positive force means repulsion and a negative force means attraction. From the given potential energy function $U(r)$ we can find the equilibrium position where force is zero. We can also find the ionisation energy which is the work done to move the particle from a certain position to infinity.

Let us consider a case in which a particle is bound to a certain point at a distance r from the centre of the force. The potential energy of the particle is : $U(r) = \frac{A}{r^2} - \frac{B}{r}$ where r is the distance from the centre of the force and A and B are positive constants. Answer the following questions.

If the total energy of the particle is $E = -\frac{3B^2}{16A}$, and it is known that the motion is radial only then the velocity is zero at

A. $\frac{r_0}{3}$

B. $\frac{2r_0}{3}$

C. r_0

D. $\frac{2r_0}{5}$

Answer: B



Watch Video Solution

13. In the figure, the variation of potential energy of a particle of mass $m = 2\text{kg}$ is represented with respect to its x -coordinate. The particle moves under the effect of this conservative force along the X -axis.

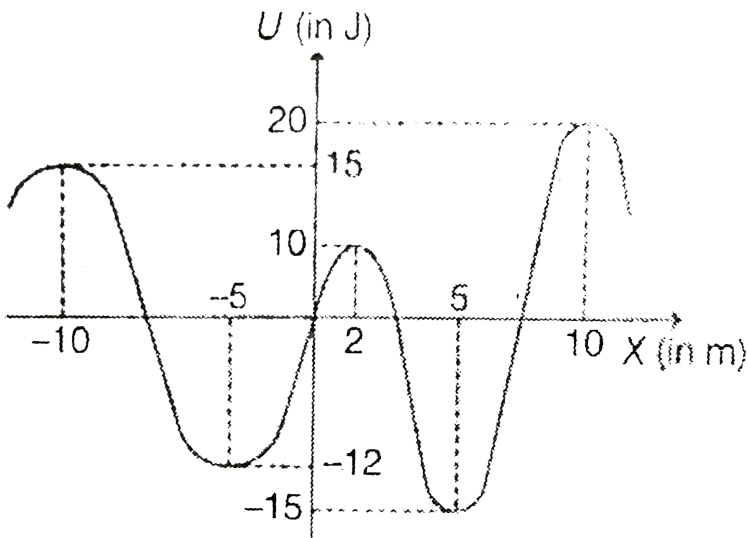

If the particle is released at the origin, then

- A. it will move towards positive x -axis
- B. it will move towards negative x -axis
- C. it will remain stationary at the origin
- D. Either of (a) or (b)

Answer: B

 Watch Video Solution

14. In the figure, the variation of potential energy of a particle of mass $m = 2\text{kg}$ is represented with respect to its x -coordinate. The particle moves under the effect of this conservative force along the X -axis.

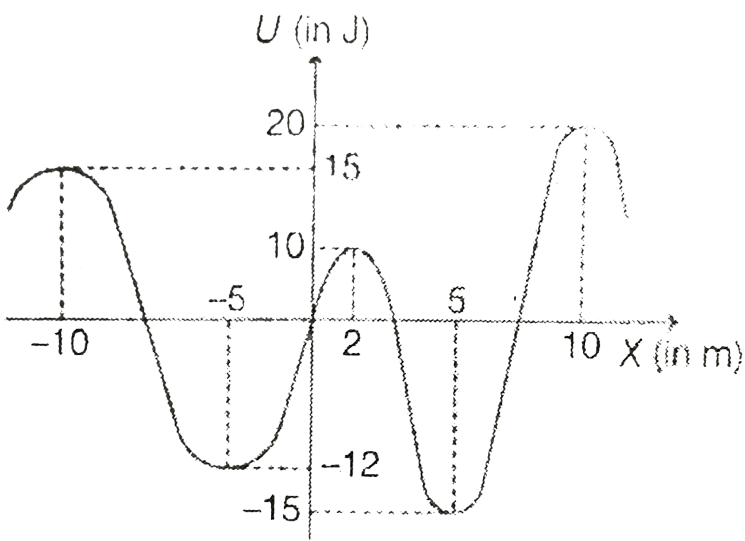

If the particle is released at $x = 2 + \Delta$ where $\Delta \rightarrow 0$ (it is positive), then its maximum speed in subsequent motion will be

A. $\sqrt{10}m / s$

B. $5m / s$

C. $5\sqrt{2}m / s$

D. $7.5m / s$

Answer: B



Watch Video Solution

15. In the figure the variation of potential energy of a particle of mass $m = 2\text{kg}$ is represented w.r.t. its x-coordinate. The particle moves under the effect of this conservative force along the x-axis.

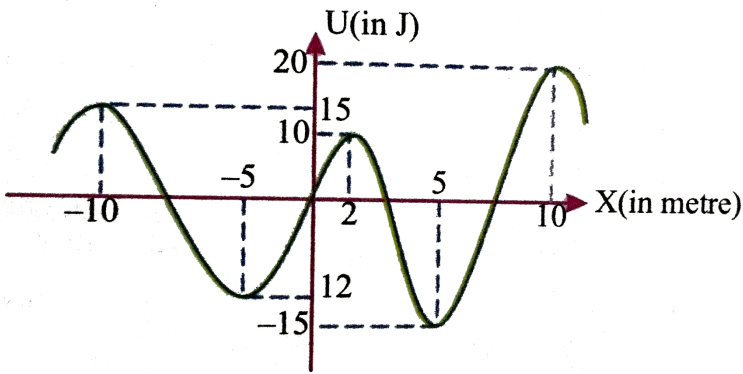

$x = -5\text{m}$ and $x = 10\text{m}$ position of the particle are respectively of

- A. neutral and stable equilibrium
- B. neutral and unstable equilibrium
- C. unstable and stable equilibrium
- D. stable and unstable equilibrium

Answer: D

 [Watch Video Solution](#)

16. A block of mass 10 kg is put gently on a belt-conveyor system of infinite length at $t = 0$, which is moving with constant speed 20 m/sec towards right at all time.

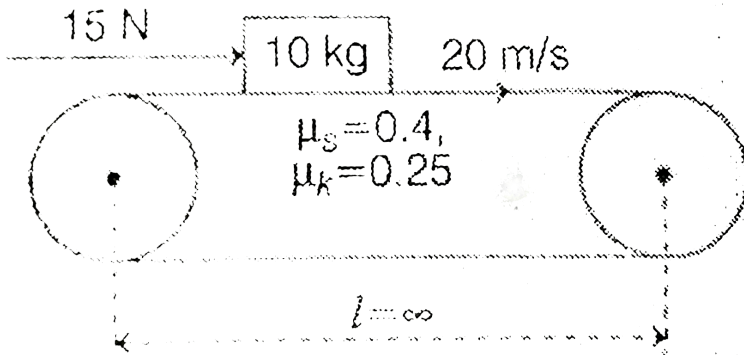

A constant force of magnitude 15 N is applied on the block continuously during its motion.

The nature of friction acting on the block of mass 10 kg during its motion is

- A. kinetic only
- B. static only
- C. some time kinetic some time static

D. can't be predicted

Answer: C

[Watch Video Solution](#)

17. A block of mass 10 kg is put gently on a belt-conveyor system of infinite length at $t = 0$, which is moving with constant speed 20 m/sec towards right at all time.

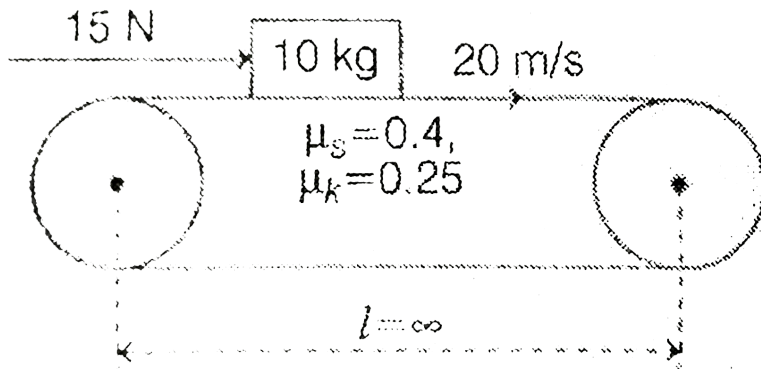

A constant force of magnitude 15 N is applied on the block continuously during its motion.

Work done by the kinetic friction on the block of mass 10 kg is

A. 1250 J

B. 2500 J

C. $-1250J$

D. $-2500J$

Answer: A



Watch Video Solution

18. A block of mass 10 kg is put gently on a belt-conveyor system of infinite length at $t = 0$, which is moving with constant speed $20m/sec$ towards right at all time.

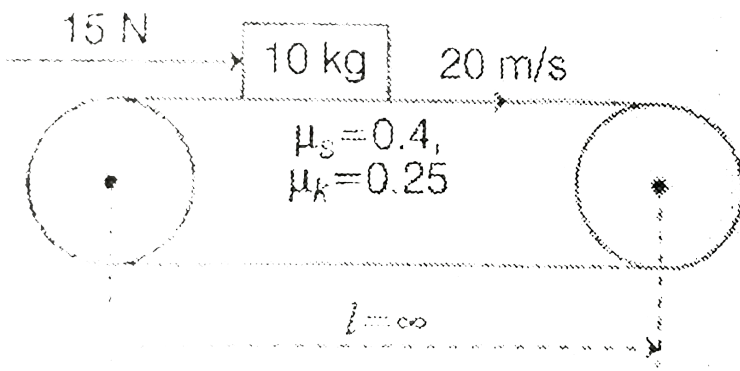

A constant force of magnitude 15 N is applied on the block continuously during its motion.

The magnitude of acceleration of the block of mass 10 kg at $t = 6\text{ s}$ is

A. 4 m/s^2

B. 3 m/s^2

C. 2 m/s

D. None of these

Answer: D



Watch Video Solution

D Matrix Matching Type Questions

1. Match the following



[View Text Solution](#)

2. A force $F=kx$ (where k is a positive constant) is acting on a particle Work done:

Column-1

- (A) in displacing the body from $x=2$ to $x=4$
- (B) In displacing the body from $x=-4$ to $x=-2$
- (C) In displacing the body from $x=-2$ to $x=+2$

Column-2

- (P) Negative
- (Q) Positive
- (R) Zero



[Watch Video Solution](#)

3. F - x and corresponding U - x graphs are as shown in figure. Three point A, B and C in F - x graph may be corresponding to P, Q and R in the U - x graph. Match the following

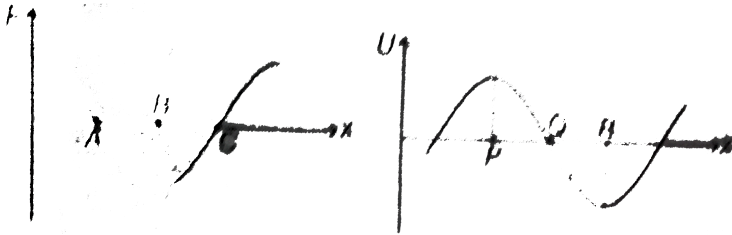

Table-1

Table-2

- (A) A
- (B) B
- (C) C

- (P) P
- (Q) Q
- (R) R
- (S) None



Watch Video Solution

4. In the system shown in figure, mass m is released from rest from position A. Potential energy of m at point A with respect to point B is E . Volume of m is negligible and all surfaces are

smooth. When mass m reaches at point B.

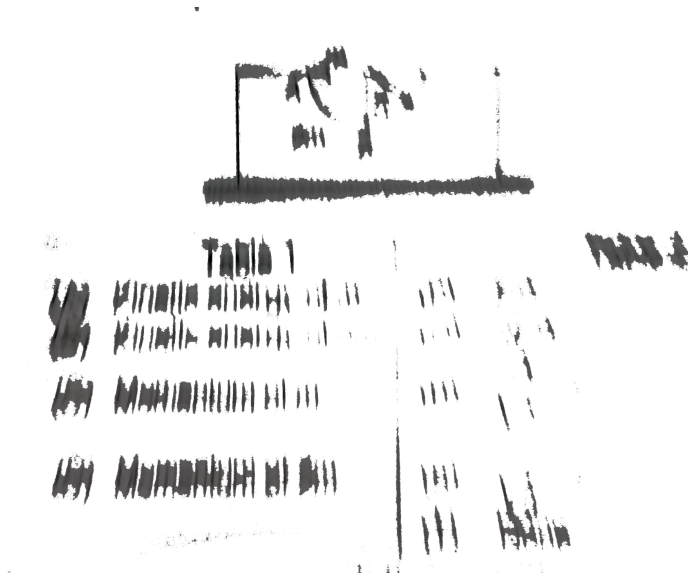

[View Text Solution](#)

5. A block of mass m is stationary with respect to a rough wedge as shown in figure. Starting from rest in time t , ($m = 1 \text{ kg}$, $\theta = 30^\circ$, $a = 2m/s^2$, $t = 4 \text{ s}$) work done on block :

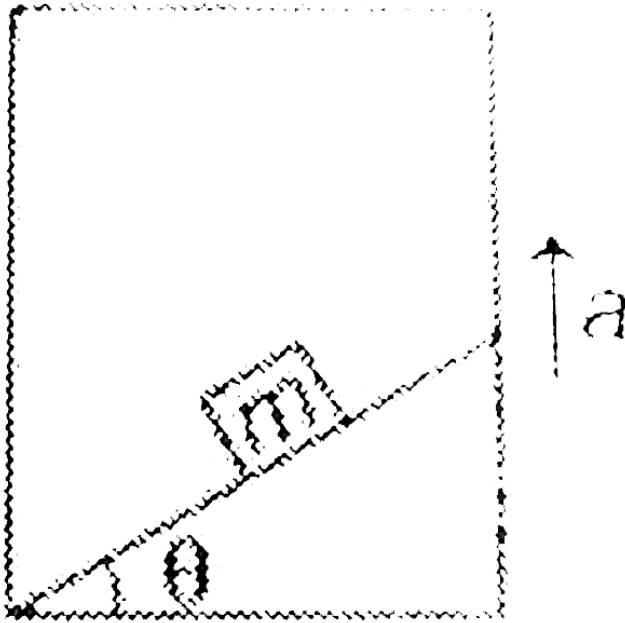

Table-1	Table-2
(A) By gravity	(P) 144J
(B) By normal reaction	(Q) 32J
(C) By friction	(R) 56J
(D) By all the forces	(S) 48J
	(T) None



Watch Video Solution

6. Acceleration versus x and potential energy versus x graph of a particle moving along x -axis is as shown in figure. Mass of the particle is 1 kg and velocity at $x = 0$ is 4 m/s . Match the following at $x = 8 \text{ m}$.

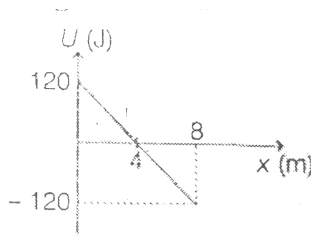
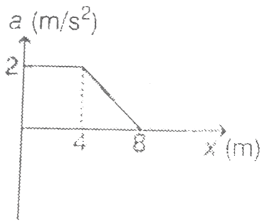

Table-1	Table-2
(A) Kinetic energy	(P) 120 J
(B) Work done by conservative forces	(Q) 240 J
(C) Total work done	(R) 128 J
(D) Work done by forces other than gravity	(S) 112 J
	(T) None



Watch Video Solution

7. A body is moved along a straight line by a machine delivering a power proportional to time ($P \propto t$). Then, match the

following.

Table-1	Table-2
(A) Velocity is proportional to	(P) t
(B) Displacement is proportional to	(Q) t^2
(C) Work done is proportional to	(R) t^3



[Watch Video Solution](#)

8. Match the following

Table-1	Table-2
(A) Electrostatic potential energy may be	(P) positive
(B) Gravitational potential energy may be	(Q) negative
(C) Elastic potential energy may be	(R) zero
(D) Magnetic potential energy may be	(S) not defined



[Watch Video Solution](#)

9. A block A of mass m kg lies on a block B of mass m kg. B in turn lies on smooth horizontal plane. The coefficient of friction between A and B is μ . Both the blocks are initially at rest. A horizontal force F is applied to lower block B at $t = 0$ till the lower block B undergoes a displacement of magnitude L . Match the statements in Table-1 with the results in Table-2.

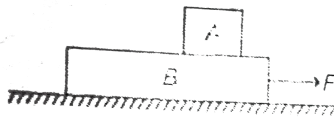

Table-1	Table-2
(A) Work done by friction force on block A is	(P) positive
(B) Work done by friction force on block B is	(Q) negative
(C) Total work done by friction on both the blocks may be	(R) less than or equal to μmgL in magnitude
(D) Work done by force F on block B is	(S) equal to μmgL in magnitude



Watch Video Solution

10. A block of mass m lies on a wedge of mass M . The wedge in turn lies on smooth horizontal surface. Friction is absent everywhere. The wedge block system is released from rest. All situations given in Table-1 are to be estimated in the duration the block undergoes a vertical displacement 'h' starting from rest. Match the statement in Table-1 with the results in Table-2

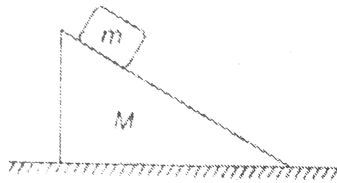

Table-1	Table-2
(A) Work done by normal reaction acting on the block is	(P) positive
(B) Work done by normal reaction (exerted by block) acting on wedge is	(Q) negative
(C) Total work done by normal reaction on both	(R) may be zero
(D) Net work done by all forces on block is	(S) less than mgh in magnitude

ltbgt



[View Text Solution](#)

E Integer Type Questions

1. A 4 kg block is on a smooth horizontal table. The block is connected to a second block of mass 1 kg by a massless flexible taut cord that passes over a frictionless pulley. The 1 kg block is 1 m above the floor. The two blocks are released from rest. With what speed does the 1 kg block hit the ground?

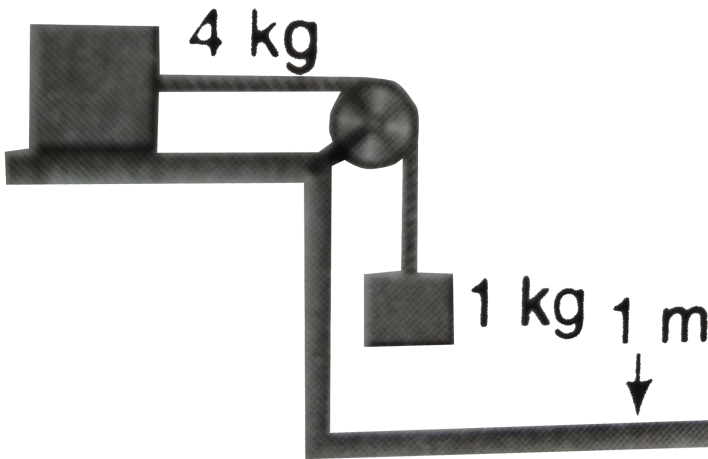

Watch Video Solution

2. A block of mass m moving at a speed v compresses a spring through a distance x before its speed is halved. The spring constant of the spring is $\frac{6mv^2}{nx^2}$. Find value of n .



[Watch Video Solution](#)

3. An open knife edge of mass 200g is dropped from height 5m on a cardboar. If the knife edge penetrates a distance 2 m into the cardboard. Find the average resistance offered by the cardboar to the knife edge (in N). ($g = 10m / s^2$)



[Watch Video Solution](#)

4. A force of $F = 0.5 \text{ N}$ is applied on lower block as shown in figure. The work done by lower block on upper block for a displacement of 6m of the upper block with respect to ground is (in J). (Take $g = 10\text{m/s}^2$).

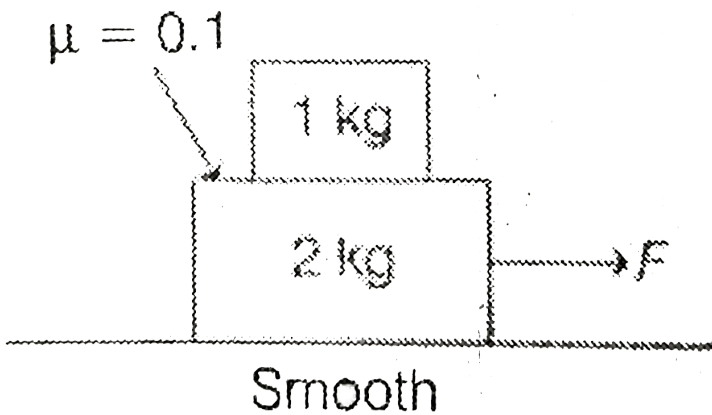

[Watch Video Solution](#)

5. A particle of mass 1 g executes an oscillatory motion on the concave surface of a spherical dish of radius 2m placed on a horizontal plane, Figure . If the motion of the particle begins

from a point on the dish at a height of 1 cm. from the horizontal plane and coefficient of friction is 0.01 , find the total distance (in meter) covered by the particle before coming to rest.

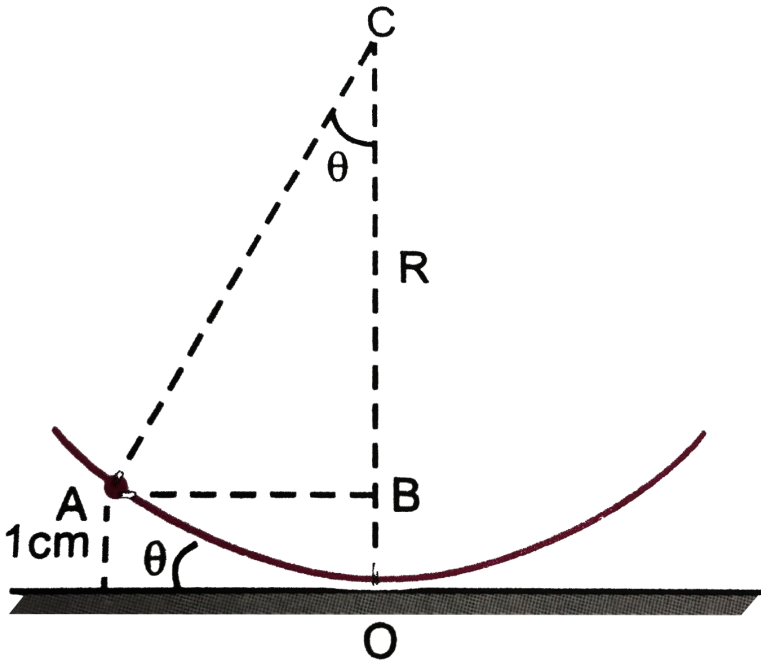

[Watch Video Solution](#)

6. An ideal massless spring S can be compressed 1 m by a force of 100 N in equilibrium. The same spring is placed at the bottom of a frictionless plane inclined at 30° to the horizontal. A 10 kg

block M is released from rest at the top of the incline and is brought to rest momentarily after compressing the spring by 2 m. If $g = 10 \text{ m/s}^2$, the speed of mass just before it touches the spring is $\sqrt{10xm} / \text{s}$. Find value of x?

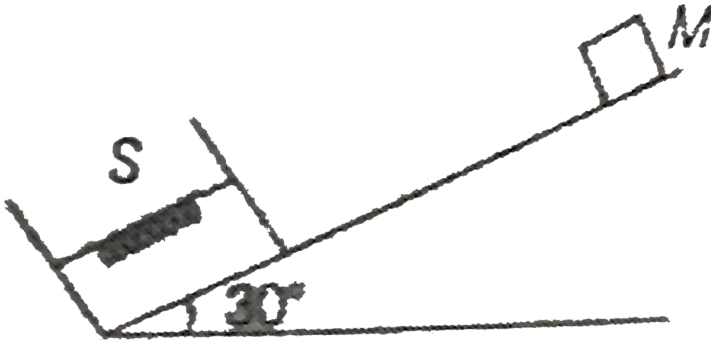

[Watch Video Solution](#)

7. Starting from rest, a 5kg object is acted upon by only one force as shown in figure. Find the total work done by the force. If

your answer is αJ then find $\alpha/15$

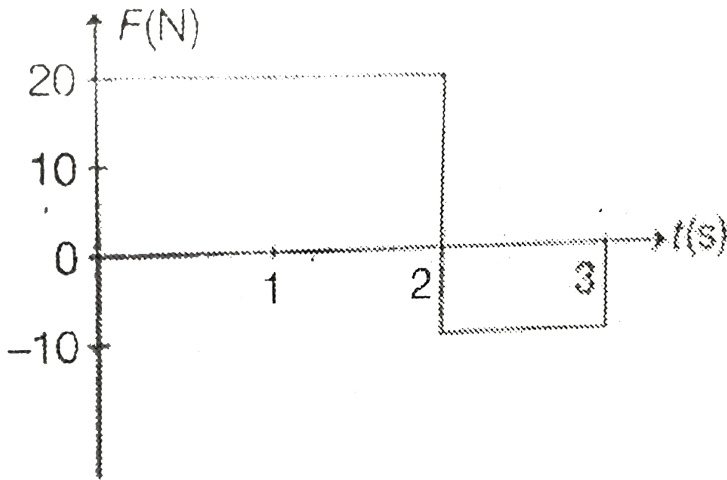

[▶ Watch Video Solution](#)

8. The power supplied by a force acting on a particle moving in a straight line is constant. The velocity of the particle varies with displacement as $x^{\frac{1}{k}}$. Find the value of k .

[▶ Watch Video Solution](#)

9. A block of mass m is connected to a massless pulley and massless spring of stiffness k . The pulley is frictionless. The string is massless. Initially the spring is unstretched when the block is released. When the spring is maximum stretched, find the ratio of tension in the rope and weight of the block.



[View Text Solution](#)

10. The potential energy of a particle is determined by the expression $U = \alpha(x^2 + y^2)$, where α is a positive constant. The particle begins to move from a point with the co-ordinates $(3, 3)$ only under the action of potential fields force. When it reaches the point $(1, 1)$ its kinetic energy is $4K\alpha$. Find the value of K .



[Watch Video Solution](#)

11. A 10 kg collar P slides with negligible friction on the fixed vertical shaft. When the collar is released from rest at the bottom position shown, it moves up the shaft under the action of the constant force $F = 200 \text{ N}$ applied to the cable. The position of the small pulley at B is fixed. Find the spring constant k (in $k - N/m$) which the spring must have if its maximum compression is to be limited to 0.4 m.



[View Text Solution](#)