



## PHYSICS

### BOOKS - DC PANDEY PHYSICS (HINGLISH)

### ELECTROSTATIC POTENTIAL AND CAPACITORS

#### Example

1. How much work will be done in bringing a charge of  $400\mu C$  from infinity to some point P in the region of electric field ? Given that the electric potential at point P is 20 V ?

A.  $0.008J$

B.  $0.006J$

C.  $0.003J$

D.  $0.08J$

**Answer: A**

 [Watch Video Solution](#)

2. Find the work done by some external force in moving a charge  $q = 2\mu C$  from infinity to a point where electric potential is  $10^4 V$ .

 [Watch Video Solution](#)

3. The electric potential at point  $A$  is  $20V$  and at  $B$  is  $-40V$ . Find the work done by an external and electrostatic force in moving an electron slowly from  $B$  to  $A$ .

 [Watch Video Solution](#)



4. Determine the potential at a point 0.50 m (i) from  $a + 20\mu C$  potential charge (ii) from  $a - 20\mu C$  point charge.

 [Watch Video Solution](#)

5. What is the electrostatic potential at the surface of a silver nucleus of diameter 12.4 fermi ? Atomic number silver is 47.

 [Watch Video Solution](#)

6. The point charges  $q_1 = 1\mu C$ ,  $q_2 = -2\mu C$  and  $q_3 = 3\mu C$  are placed at  $(1m, 0, 0)$ ,  $(0, 2m, 0)$  and  $(0, 0, 3m)$  respectively. Find the electric potential at origin.

A.  $9000V$

B.  $90000V$

C.  $90V$

D.  $980V$

**Answer: A**



[Watch Video Solution](#)

7. In the given figure, there are four point charges placed at the vertices of a square of side,  $a = 1.4m$ . If  $q_1 = +18nC$ ,  $q_2 = -24nC$ ,  $q_3 = +35nC$  and  $q_4 = +16nC$  then find the electric at the centre P of the square Assume the potential to be zero at infinity.



[Watch Video Solution](#)

8. Suppose that three point charges,  $q_a$ ,  $q_b$  and  $q_c$  are arranged at the vertices of a right-angled triangle, as shown. What is the absolute potential at the position of the third charge, if  $q_a = 6.0\mu C$ ,  $q_b = +4.0\mu C$ ,  $q_c = +2.0\mu C$ ,  $a = 4.0m$  and  $b = 3.0m$ ?



 [Watch Video Solution](#)

9. (a) The charges each  $Q$  are placed at  $x = d, 2d, 4d, \dots, \infty$ . Find electric potential at origin  $O$ .

(b) A charge  $+Q$  is placed at each of the points  $x = d, x = 3d, x = 5d, \dots, \infty$  on the  $x$ -axis, and a charge  $-Q$  is placed at each of the points  $x = 2d, x = 4d, x = 6d, \dots, \infty$ . Find the electric potential at the origin  $O$ .

 [Watch Video Solution](#)

10. A charge  $Q$  is distributed uniformly on a ring of radius  $R$  as shown in the following diagrams. Find the electric potential at the centre  $O$  of the ring



 [Watch Video Solution](#)

11. Find out the points on the line joining two charges  $+q$  and  $-3q$  (kept at a distance of  $1.0\text{m}$ ) where electric potential is zero.

 [Watch Video Solution](#)

12. Two charges  $3 \times 10^{-8}\text{C}$  and  $-2 \times 10^{-8}\text{C}$  are located  $15\text{cm}$  apart. At what point on the line joining the two charges is the electric potential zero? Take the potential at infinity to be zero.



 Watch Video Solution

13. The electric potential in a region is represented as

$$V = 2x + 3y - z$$

obtain expression for electric field strength.

A.  $2i + 3j - k$

B.  $2i + 3j + k$

C.  $2i - 3j - k$

D.  $-2i + 3j - k$

**Answer: A**

 Watch Video Solution

14. Find  $V_{ab}$  in an electric field  $\vec{E} = (2\hat{i} + 3\hat{j} + 4\hat{k})NC^{-1}$  where  $\vec{r}_a = (\hat{i} - 2\hat{j} + \hat{k})m$  and  $\vec{r}_b = (2\hat{i} + \hat{j} - 2\hat{k})m$ .

 Watch Video Solution

15. A uniform electric field of  $100\text{V}/\text{m}$  is directed at  $30^\circ$  with the positive x-axis as shown in figure. Find the potential difference  $V_{BA}$  if  $OA = 2\text{m}$  and  $OB = 4\text{m}$ .

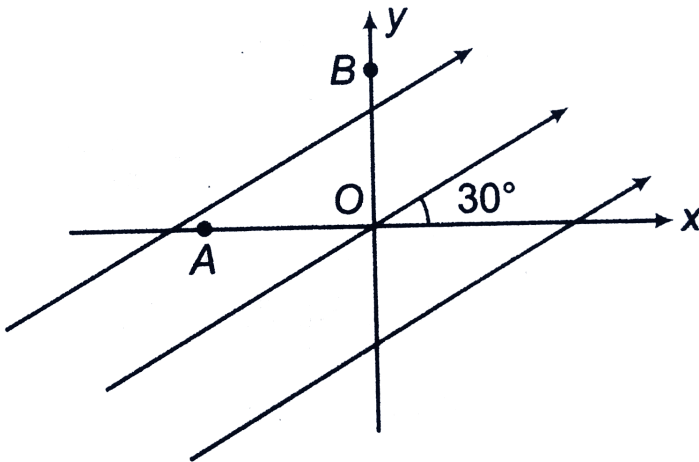

 Watch Video Solution

16. Two points A and B are 2 cm apart and a uniform electric field  $E$  acts along the straight line  $AB$  directed A to B with  $E = 200\text{N}/\text{C}$ .

A particle of charge  $+10^{-6}C$  is taken from A to B along AB,

Calculate

- the force on the charge
- the potential difference  $V_A - V_B$  and
- the work done on the charge by E

 [Watch Video Solution](#)

17. An electric field  $E = (20\hat{i} + 30\hat{j})$  N/C exists in the space. If the potential at the origin is taken be zero, find the potential at  $(2m, 2m)$ .

 [Watch Video Solution](#)

18. Equipotential spheres are drawn round a point charge. As we move away from charge will the spacing between two spheres

having a constant potential difference decrease, increase or remain constant.



[Watch Video Solution](#)

**19.** A charge  $q = 10\mu C$  is distributed uniformly over the circumference of a ring of radius 3m placed on x-y plane with its centre at origin. Find the electric potential at a point  $P(0, 0, 4m)$



[Watch Video Solution](#)

**20.** Two identical thin rings, each of radius R meters, are coaxially placed a distance R metres apart. If  $Q_1$  coulomb, and  $Q_2$  coulomb, are respectively the charges uniformly spread on the two rings, the work done in moving a charge q from the centre of one ring to that of the other is



[Watch Video Solution](#)



21. A spherical drop of water carrying a charge of  $3 \times 10^{-10} C$  has potential of  $500V$  at its surface. When two such drops having same charge and radius combine to form a single spherical drop, what is the potential at the surface of the new drop?

A.  $594V$

B.  $794V$

C.  $694V$

D.  $894V$

**Answer: B**



**Watch Video Solution**

22. A charge  $Q$  is distributed over two concentric hollow spheres of radii  $r$  and  $R$  ( $> r$ ) such that the surface charge densities are equal. Find the potential at the common centre.

A.  $\frac{KQ(r + R)}{r^2 + R^2}$

B.  $\frac{KQ(r + R)}{r^2 - R^2}$

C.  $\frac{KQ(r - R)}{r^2 + R^2}$

D.  $\frac{KQ(r - R)}{r^2 - R^2}$

**Answer: A**



**Watch Video Solution**

23. A bullet of mass  $2gm$  is having a charge of  $2\mu c$ . Through what potential difference must it be accelerated, starting from rest, to acquire a speed of  $10m/s$

 [Watch Video Solution](#)

24. A ball of mass  $m$  having a charge  $q$  is released from rest in a region where a horizontal electric field  $E$  exists.

(a) Find the resultant force acting on the ball.

(b) Find the trajectory followed by the ball.

 [Watch Video Solution](#)

25. A block having mass ' $m$ ' and charge  $q$  is resting on a frictionless plane at distance  $L$  from the wall as shown in fig. Discuss the motion of the block when a uniform electric field  $E$  is applied horizontally towards the wall assuming that collision of the block with the wall is perfectly elastic.

 [Watch Video Solution](#)

**26.** Two point charges each  $50\mu C$  are fixed on  $y$ -axis at  $y = +4m$  and  $y = -4m$ . Another charged particle having charge  $-50\mu C$  and mass  $20g$  is moving along the positive  $x$ -axis. When it is at  $x = -3m$ , its speed is  $20m/sec$ . Find the speed of charged particle when it reaches to origin. Also, find distance of charged particle from origin, when its kinetic energy becomes zero.

 [Watch Video Solution](#)

**27.** A spherical oil drop, radius  $10^{-4}$  cm has on it at a certain a total charge of 40 electrons. Calculate the energy that would be required to place an additional electron on the drop.

 [Watch Video Solution](#)

**28.** A uniform electric field  $E_0$  is directed along positive y-direction.

Find the change in electric potential energy of a positive test charge  $q_0$  when it is displaced in this field from  $y_i = a$  to  $y_f = 2a$  along the y-axis.



[Watch Video Solution](#)

**29.** Find the change in electric potential energy,  $\Delta U$  as a charge of  $2.20 \times 10^{-6}C$ , mass from a point A to point B, given that the change in electric potential between these points is  $\Delta V = V_B - V_A = 24.0V$ .



[Watch Video Solution](#)

**30.** Three charges 0.1 coulomb each are placed on the corners of an equilateral triangle of side  $1m$ . If the energy is supplied to this

system at the rate of  $1\text{kW}$  how much time would be required to move one to the charges on to the midpoint of the line joining the two ?



[Watch Video Solution](#)

31. In a hydrogen atom, the electron and proton are bound together at a distance of about  $0.53 \text{ \AA}$ . Estimate the potential energy of the system in eV, assuming zero potential energy at infinite separation between the electron and the proton.

A. 21.8

B. 17.4

C. 27.2

D. None of these

**Answer: C**

 Watch Video Solution

**32.** A point charge  $q_1 = -5.8\mu\text{C}$  is held stationary at the origin. A second point charge  $q_2 = +4.3\mu\text{C}$  moves from the point  $(0.26\text{m}, 0, 0)$  to  $(0.38\text{m}, 0, 0)$ . How much work is done by the electric force on  $q_2$ ?

 Watch Video Solution

**33.** What minimum work must be done by an external force to bring a charge  $q = 3.00\mu\text{C}$  from a great distance away (take  $t = \infty$ ) to a point  $0.500\text{m}$  from a charge  $Q = 20.0\mu\text{C}$ ?

A.  $1.08\text{J}$

B.  $2.08\text{J}$

C.  $1.98\text{J}$

D.  $2.98J$

**Answer: A**

 [Watch Video Solution](#)

**34.** A point charge  $q_1 = 9.1\mu C$  is held fixe at origin. A second pont charge  $q_2 = -0.42\mu C$  and a mass  $3.2 \times 10^{-4}kg$  is placed on the x-axis,  $0.96m$  from the origin. The second point charge is released at rest. What is its speed when it is  $0.24m$  from the origin?

 [Watch Video Solution](#)

**35.** An alpha particle with kinetic energy  $10MeV$  is heading toward a stationary tin nuclcus of atomic number 50. Calculate the



distance of closest approach (Fig . 3.23).

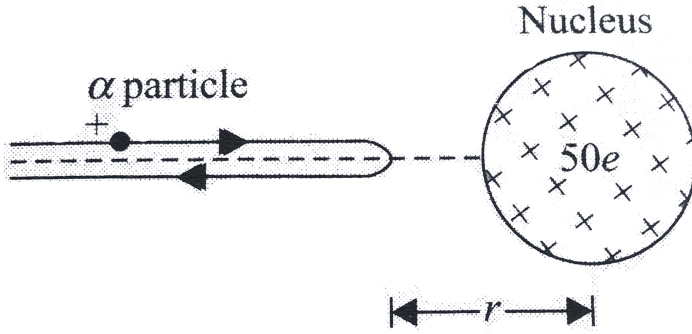

[Watch Video Solution](#)

**36.** A proton is fixed at origin. Another proton is released from rest, from a point at a distance  $r$  from origin. Taking charge of portion as  $e$  and mass as  $m$ , find the speed of the proton (i) at a distance  $2r$  from origin (ii) at large distance from origin.



[Watch Video Solution](#)

**37.** A uniformly charged thin ring has radius  $10.0\text{ cm}$  and total charge  $+12.0\text{ nC}$ . An electron is placed on the ring's axis a distance  $25.0\text{ cm}$  from the centre of the ring and is constrained to stay on the axis of the ring. The electron is then released from rest, then

(i) describe the subsequent motion of the electron

(ii) find the speed of the electron when it reaches the centre of the ring.



**Watch Video Solution**

**38.** Three point charges of  $1\text{ C}$ ,  $2\text{ C}$  and  $3\text{ C}$  are placed at the corners of an equilateral triangle of side  $100\text{ cm}$ . Find the work done to move these charges to the corners of a similar equilateral triangle of side  $50\text{ cm}$ .

A.  $9.9 \times 10^{19}\text{ J}$

B.  $6.9 \times 10^{10}\text{ J}$

C. 0

D.  $9.9 \times 10^{10} J$

**Answer: D**



**Watch Video Solution**

**39.** Four charges  $q_1 = 1\mu C$ ,  $q_2 = 2\mu C$ ,  $q_3 = -3\mu C$  and  $q_4 = 4\mu C$  are kept on the vertices of a square of side  $1m$ . Find the electric potential energy of this system of charges.



**Watch Video Solution**

**40.** Two points charges are located on the x-axis,  $q_1 = -1\mu C$  at  $x = 0$  and  $q_2 = +1\mu c$  at  $x = 1m$ .

- a. Find the work that must be done by an external force to bring a third point charge  $q_3 = +1\mu C$  from infinity to  $x = 2m$ .
- b. Find the total potential energy of the system of three charges.

 [Watch Video Solution](#)

41. Two point charges  $q_1 = q_2 = 2\mu C$  are fixed at  $x_1 = +3m$  and  $x_2 = -3m$  as shown in figure. A third particle of mass 1 g and charge  $q_3 = -4\mu C$  are released from rest at  $y = 4.0m$ . Find the speed of the particle as it reaches the origin.

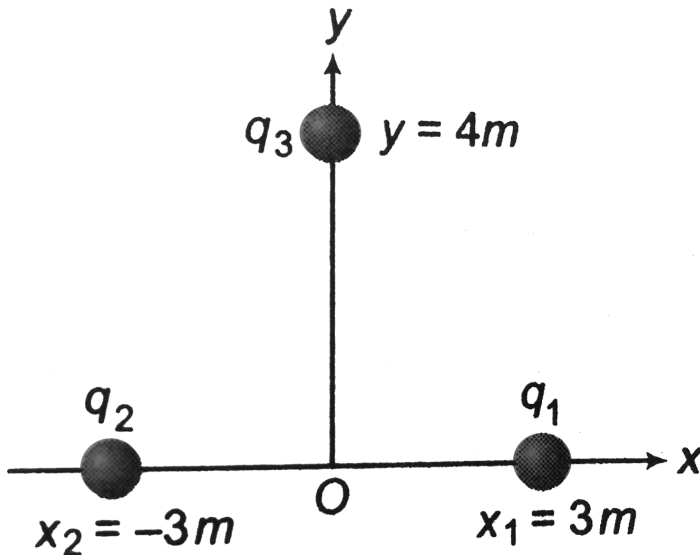

 [Watch Video Solution](#)

42. When an electric dipole is placed in a uniform electric field making angle  $\theta$  with electric field, it experiences a torque  $\tau$ . Calculate the minimum work done in changing the orientation to  $2\theta$ .

 [Watch Video Solution](#)

43. Two point-charges  $+2e$  and  $-2e$  are situated at a distance of  $2.4\text{\AA}$  from each other and constitute an electric dipole. This dipole is placed in a uniform electric field of  $4.0 \times 10^5 \text{Vm}^{-1}$ . Calculate

- electric dipole moment,
- potential energy of the dipole in equilibrium position,
- work done in rotating the dipole through  $180^\circ$  from the equilibrium position.

 [Watch Video Solution](#)

44. Figure shows two conducting thin concentric shells of radii  $r$  and  $3r$ . The outer shell carries a charge  $q$ . Inner shell is neutral. Find the charge that will flow from inner shell to earth the switch  $S$  is closed.

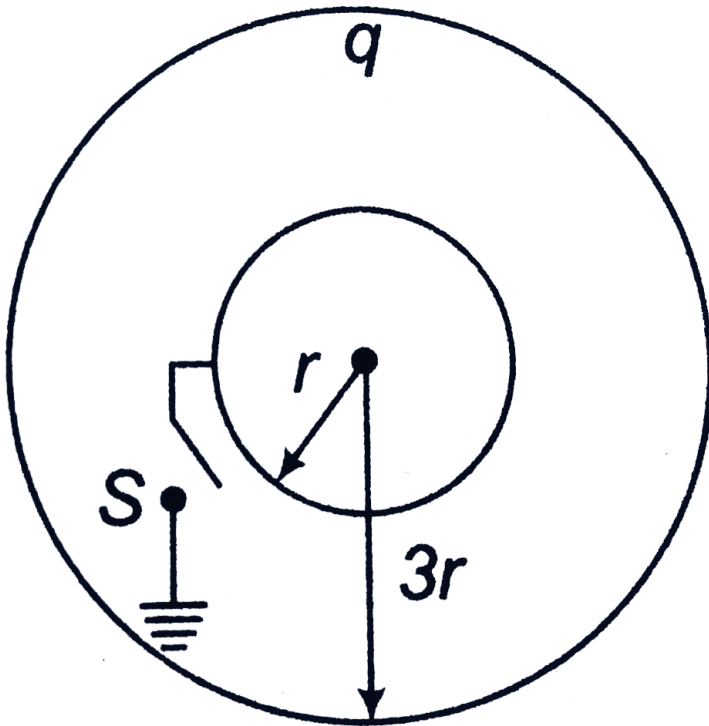

[Watch Video Solution](#)

45. A sphere of  $4\text{cm}$  radius is suspended within a hollow sphere of  $6\text{cm}$  radius. The inner sphere is charged to potential 3 e.s.u. and the outer sphere is earthed. The charge on the inner sphere is



[Watch Video Solution](#)

46. A capacitor of  $0.75\mu\text{F}$  is charged to a voltage of  $16\text{V}$ . What is the magnitude of the charge on each plate of the capacitor ?

A.  $6\mu\text{C}$

B.  $24\mu\text{C}$

C.  $20\mu\text{C}$

D.  $12\mu\text{C}$

**Answer: D**



[Watch Video Solution](#)

47. A sphere of radius  $0.03m$  is suspended within a hollow sphere of radius  $0.05m$ . If the inner sphere is charged to a potential of 1500 volt and outer sphere is earthed. Find the capacitance and the charge of the inner sphere.

 [Watch Video Solution](#)

48. The thickness of air layer between two coating of a spherical capacitor is 2cm. The capacitor has same capacitance as the sphere of 1.2m diameter. Find the radii of its surfaces.

 [Watch Video Solution](#)

49. A parallel plate capacitor is constructed with plates of area  $0.0280m^2$  and separation  $0.550mm$ . Find the magnitude of the charge on each plate of this capacitor when the potential between



the plates is  $20.1V$



A.  $2 \cdot 10^{-9}C$

B.  $9 \cdot 10^{-9}C$

C.  $9 \cdot 10^{-10}C$

D.  $9 \cdot 10^{-19}C$

**Answer: B**



**Watch Video Solution**

**50.** A dielectric slab of thickness  $1.0\text{ cm}$  and dielectric constant  $5$  is placed between the plates of a parallel plate capacitor of plate area  $0.01\text{m}^2$  and separation  $2.0\text{ cm}$ . Calculate the change in capacity on introduction of dielectric. What would be on the change, if the dielectric slab were conducting?

A. 
$$\frac{8.85 \cdot 10^{-12}}{3}$$

B. 
$$\frac{8.85 \cdot 10^{-2}}{3}$$

C. 
$$\frac{1.85 \cdot 10^{-12}}{3}$$

D. 
$$\frac{8.85 \cdot 10^{-12}}{2}$$

**Answer: A**

 [Watch Video Solution](#)

**51.** A parallel plate capacitor has plate  $A$  and separation  $d$  between the plates. The capacitor is connected to a battery of emf  $V$ . (a) find the charge on the capacitor. (b) the plate separation is decreases to  $d/2$ . Find the extra charge given by the battery to the positive plate. (c) work done in reducing separation between plates.

A. 
$$\epsilon_0 A \frac{V}{d}, \epsilon_0 A \frac{V}{d}, \frac{\epsilon_0 AV}{2d}$$

B. 
$$\epsilon_0 A \frac{V}{d}, \epsilon_0 A \frac{V}{d}, \frac{\epsilon_0 AV^2}{d}$$

C.  $\epsilon_0 A \frac{V}{d}$ ,  $\epsilon_0 A \frac{V}{d}$ ,  $\frac{\epsilon_0 A V^2}{2d}$

D.  $\epsilon_0 2A \frac{V}{d}$ ,  $\epsilon_0 A \frac{V}{d}$ ,  $\frac{\epsilon_0 A V^2}{2d}$

**Answer: C**



**Watch Video Solution**

**52.** The distance between the plates of a parallel plate capacitor is  $0.04m$ . A field of  $5000V/m$  is established between the plates and an unchanged metal plate of thickness  $0.01m$  is inserted into the condenser parallel to its plate. Find the  $p. d.$  between the plates (a) before the introducing of the metal plate and (b) after its introduction. what would be the  $p. d.$  if plate of dielectric constant  $K = 2$  is introduced in place of metal plate?

A.  $200V$ ,  $150V$ ,  $175V$

B.  $200V$ ,  $150V$ ,  $275V$

C.  $100V$  ,  $150V$  ,  $175V$

D.  $400V$  ,  $150V$  ,  $175V$

**Answer: A**



**Watch Video Solution**

**53.** An isolated  $16\mu F$  parallel plate air capacitor has a potential difference of  $100 V$ . dielectric slab having relative permittivity (i.e., dielectric constant) =  $5$  is introduced to fill the space between the two plates completely. Calculate.



(i) the new capacitance of the capacitor

(ii) the new potential difference between the two plates of capacitor.

A.  $80 \mu F$

B.  $12 \mu F$

C. 36  $\mu\text{F}$

D. 40  $\mu\text{F}$

**Answer: A**



[Watch Video Solution](#)

**54.** A capacitor ( $C = 50\mu\text{F}$ ) is charged to a potential difference of  $20\text{V}$ . The charging battery is disconnected and the capacitor is connected to another cell of emf  $10\text{V}$  with the positive plate of capacitor joined with the positive terminal of cell.

(a) find charge flown through  $10\text{V}$  cell.

(b) is work done by the cell or is it done on the cell? find its magnitude.

(c) find the heat developed in connecting wires.



[Watch Video Solution](#)

55. A parallel plate capacitor ( $C = 50\mu F$ ,  $d = 4mm$ ) is charged to  $200V$  and then charging battery is removed. Now a dielectric slab ( $K = 4$ ) of thickness  $2mm$  is placed between the plates. Find new potential difference across capacitor.

- A. 62.5 V
- B. 12.5 V
- C. 10 V
- D. 15 V

**Answer: A**



[Watch Video Solution](#)

56. In the circuit shown in figure find

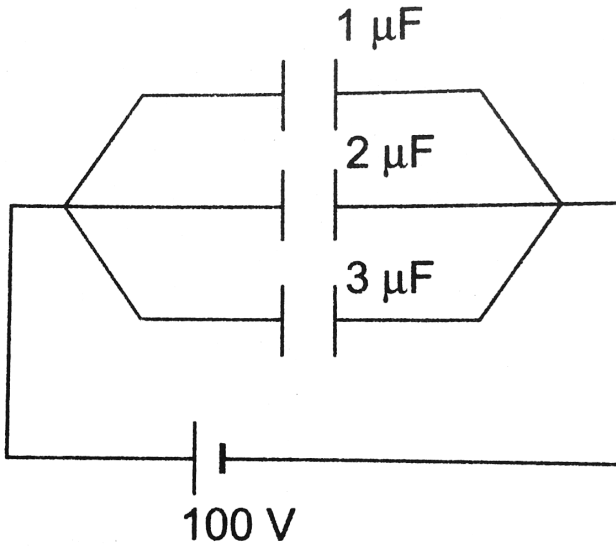

- a. the equivalent capacitance and
- b. the charge stored in each capacitor.

- A. 6
- B. 2
- C. 3
- D. 1

**Answer: A**



Watch Video Solution

57. Find the potential difference and charge on each capacitor.

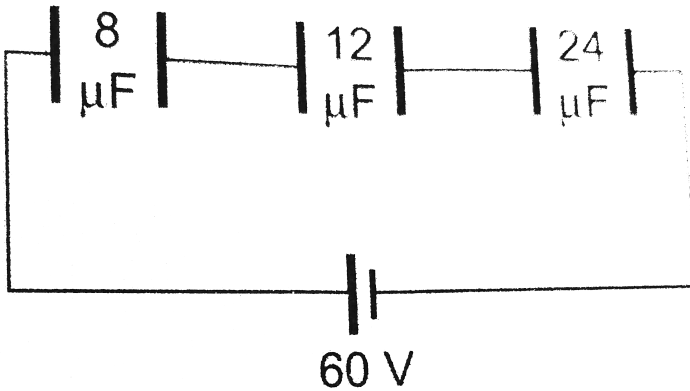

- A. 30 V , 20 V and 10V
- B. 30 V , 10 V and 20V
- C. 20 V , 30 V and 10V
- D. 30 V , 20 V and 20V

Answer: A





58. In the circuit shown in figure find

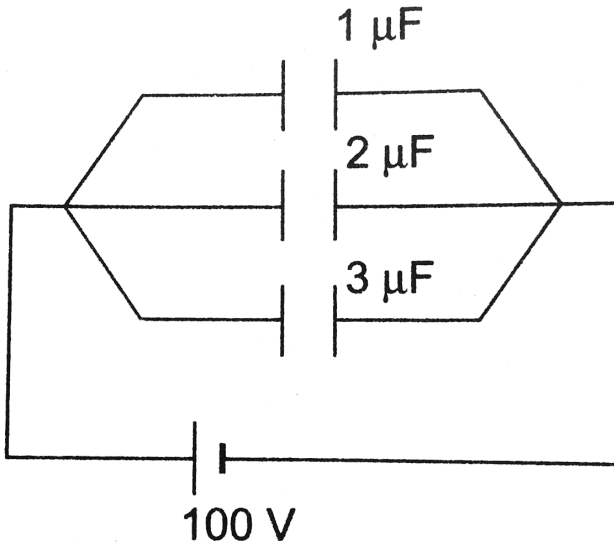

- the equivalent capacitance and
- the charge stored in each capacitor.

- $6 \mu\text{F}$   $100 \mu\text{C}$   $200 \mu\text{C}$   $300 \mu\text{C}$
- $6 \mu\text{F}$   $100 \mu\text{C}$   $200 \mu\text{C}$   $200 \mu\text{C}$
- $1 \mu\text{F}$   $100 \mu\text{C}$   $200 \mu\text{C}$   $300 \mu\text{C}$
- $6 \mu\text{F}$   $200 \mu\text{C}$   $200 \mu\text{C}$   $200 \mu\text{C}$

Answer: A

 Watch Video Solution

59. Find the equivalent capacitance between  $A$  and  $B$ .  $A$ : area of each plate,  $d$ : separation between the plates.

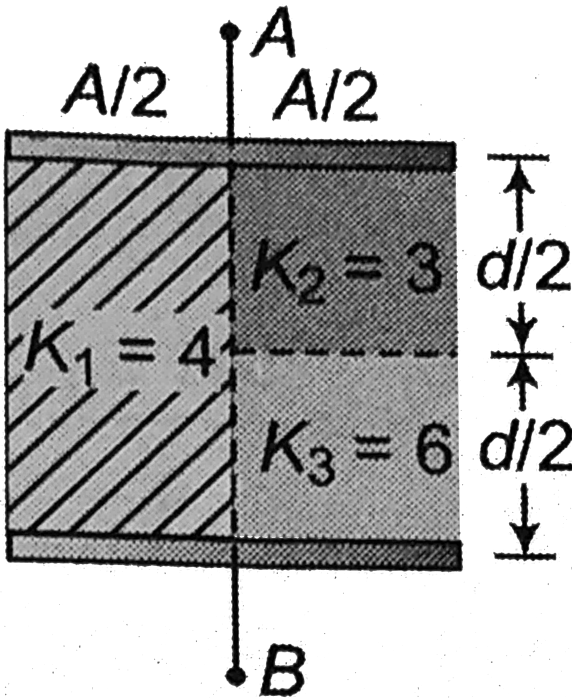

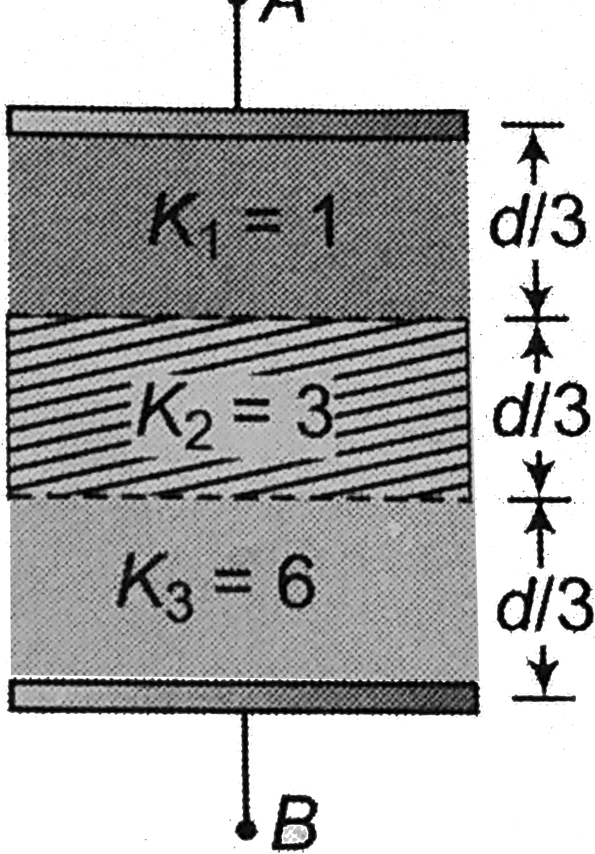

[▶ Watch Video Solution](#)

60. Find the potential difference and charge on each capacitance.

All capacitances are in  $\mu F$ .

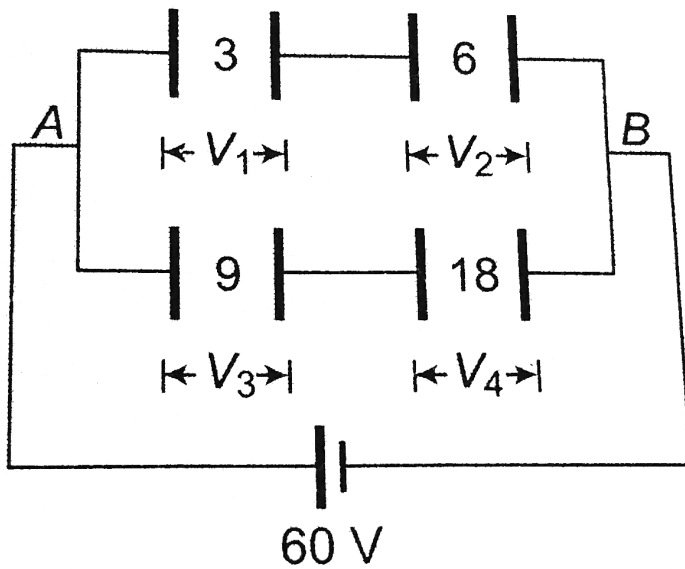

- A.  $V_1 = 40$  ,  $V_2 = 20$  ,  $V_3 = 40$  ,  $V_4 = 20$
- B.  $V_1 = 20$  ,  $V_2 = 20$  ,  $V_3 = 40$  ,  $V_4 = 20$
- C.  $V_1 = 40$  ,  $V_2 = 40$  ,  $V_3 = 40$  ,  $V_4 = 20$
- D.  $V_1 = 40$  ,  $V_2 = 20$  ,  $V_3 = 40$  ,  $V_4 = 10$

**Answer: A**

 [Watch Video Solution](#)

**61.** In the following figures, area of each plate is  $A$  and  $d$  is separation between adjacent plates. Find the capacitance of system

between points *A* and *B*.

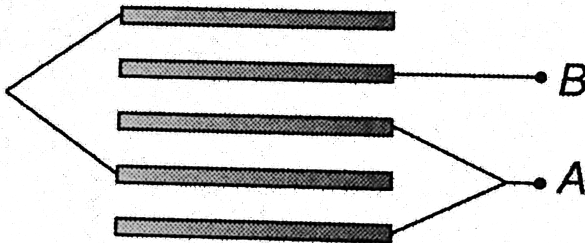
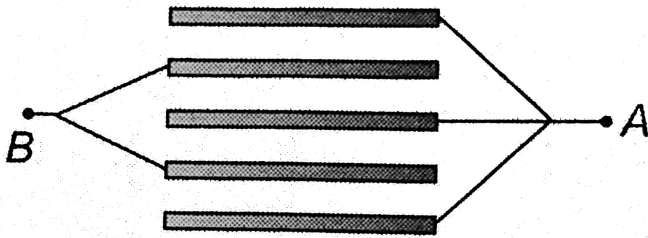
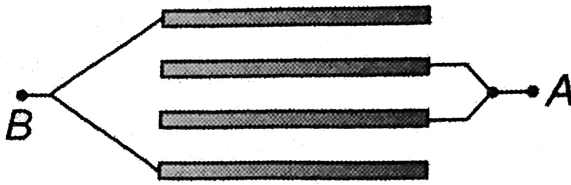
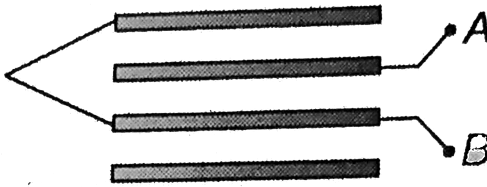

 Watch Video Solution

62. Find the equivalent capacitance between  $A$  and  $B$ .

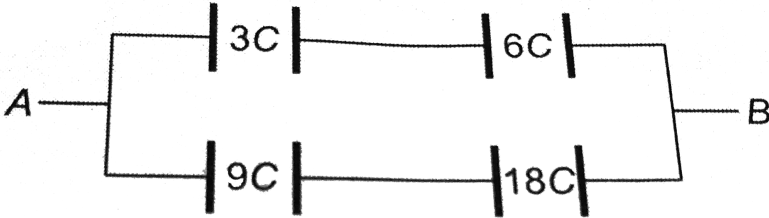

 Watch Video Solution

63. Find the charges on the three capacitors shown in figure

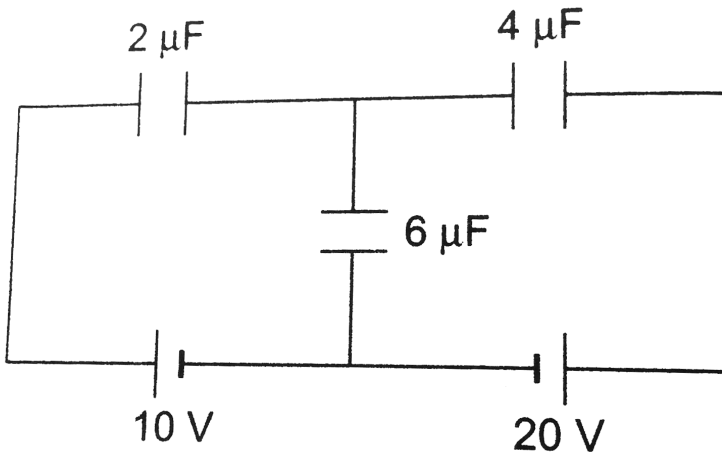

 [Watch Video Solution](#)

64. Calculate energy stored in a capacitor of  $5\mu F$  when it is charged to a potential of 250 volt.

A. 0.156 J

B. 0.25 J

C. 0.5 J

D. 0.3 J

**Answer: A**

 [Watch Video Solution](#)

65. The plates of a parallel plate capacitor have an area of  $90\text{cm}^2$  each and are separated by  $2.5\text{mm}$ . The capacitor is charged to 400 V. How much electrostatic energy is stored in it? How much when it



is filled with a dielectric medium  $K = 3$  and then charged ? If it is first charged as an air capacitor and then filled with th dielectric, then ?

 [Watch Video Solution](#)

66. Two capacitors of capacitances  $C_1 = 2\mu F$  and  $C_2 = 8\mu F$  are connected in series and the resulting combination is connected across a  $300V$  battery. Calculate the charge, potential difference and energy stored in the capacitor separately.

- A.  $4.8 \times 10^{-4}C$  ,  $240V$  ,  $60V$  ,  $0.072J$
- B.  $4.8 \times 10^{-4}C$  ,  $240V$  ,  $60V$  ,  $0.0072J$
- C.  $4.8 \times 10^{-4}C$  ,  $60V$  ,  $60V$  ,  $0.0072J$
- D.  $4.8 \times 10^{-3}C$  ,  $240V$  ,  $60V$  ,  $0.0072J$

**Answer: B**

 [Watch Video Solution](#)

**67.** The capacitance of a variable radio capacitor can be changed from  $50\text{pF}$  to  $200\text{pF}$  by turning the dial from  $0^\circ$  to  $180^\circ$ . With the dial set at  $180^\circ$ , the capacitor is connected to a  $400\text{V}$  battery. After charging, the capacitor is disconnected from the battery and dial is tuned at  $0^\circ$ ?

(a) what is the *p. d.* across the capacitor when dial reads  $0^\circ$ ?

(b) how much work is required to turn the dial, if friction is neglected?

 [Watch Video Solution](#)

**68.** Two isolated spherical conductors have radii  $5\text{cm}$  and  $0\text{cm}$ , respectively. They have charges of  $12\mu\text{C}$  and  $-3\mu\text{C}$ . Find the charges after they are connected by a conducting wire. Also find the common potential after redistribution.



[Watch Video Solution](#)

**69.** Two parallel plates capacitors A and B having capacitance of  $1\mu F$  and  $5\mu F$  are charged separately to the same potential of 100 V. Now, the positive plate of A is connected to the negative plate of B and the negative plate of A to the positive plate of B. Find the final charges on each capacitors.



[Watch Video Solution](#)

**70.** A capacitor of capacitance  $5\mu F$  is charged to potential  $20V$  and isolated. Now, an uncharged capacitor is connected in parallel to it. If the charge distributes equally on these capacitors, find total energy stored in capacitors.



[Watch Video Solution](#)

71. A capacitor  $A$  of capacitance  $4\mu F$  is charged to  $30V$  and another capacitor  $B$  of capacitance  $\mu F$  is charged to  $15V$ . Now, the positive plate of  $A$  is connected to the negative plate of  $B$  and negative plate of  $A$  to the positive plate of  $B$ . find the final charge of each capacitor and loss of electrostatic energy in the process.

 [Watch Video Solution](#)

## Check point 2.1

1. Find the work done by some external force in moving a charge  $q = 4\mu C$  from infinity to a point, where electric potential is  $10^4 V$

A.  $4 \times 10^{-2} J$

B.  $2 \times 10^{-2} J$

C.  $8 \times 10^{-2} J$

D.  $1 \times 10^{-2} J$

**Answer: A**



**Watch Video Solution**

2. Equal charges are given to two spheres of different radii. The potential will

- A. be more on the smaller sphere
- B. be more on the bigger sphere
- C. be equal on both the spheres
- D. depend on the nature of the materials of the spheres

**Answer: A**



**Watch Video Solution**

3. The electric potential at a point in free space due to a charge  $Q$  coulomb is  $Q \times 10^{11}$  volts. The electric field at that point is

A.  $4\pi\epsilon_0 Q \times 10^{20} \text{Vm}^{-1}$

B.  $12\pi\epsilon_0 Q \times 10^{22} \text{Vm}^{-1}$

C.  $4\pi\epsilon_0 Q \times 10^{22} \text{Vm}^{-1}$

D.  $12\pi\epsilon_0 Q \times 10^{20} \text{Vm}^{-1}$

**Answer: C**

 [Watch Video Solution](#)

4. In an hydrogen atom, the electron revolves around the nucleus in an orbit of radius  $0.53 \times 10^{-10} \text{m}$ . Then the electrical potential produced by the nucleus at the position of the electron is

A.  $-13.6 \text{V}$

B.  $-27.2V$

C.  $27.2V$

D.  $13.6V$

**Answer: C**



**Watch Video Solution**

5. Three charges  $2q$ ,  $-q$ , and  $-q$  are located at the vertices of an equilateral triangle. At the center of the triangle,

A. the field is zero but potential is non-zero

B. the field is non-zero but potential is zero

C. Both field and potential are zero

D. Both field and potential are non-zero

**Answer: B**



[Watch Video Solution](#)

6. In a region of constant potential

- A. the electric field is uniform
- B. the electric field is zero
- C. there can be no charge inside the region
- D. the electric field shall necessarily change if a charge is placed outside the region

**Answer: B**



[Watch Video Solution](#)

7. The work done in bringing a 20 coulomb charge from point  $A$  to point  $B$  for distance  $0.2m$  is  $2J$ . The potential difference between



the two points will be (in volt)

A. 0.2

B. 8

C. 0.1

D. 0.4

**Answer: C**



**Watch Video Solution**

8. As shown in the figure, charges  $+q$  and  $-q$  are placed at the vertices  $B$  and  $C$  of an isoscles triangle. The potential at the vertex

A is

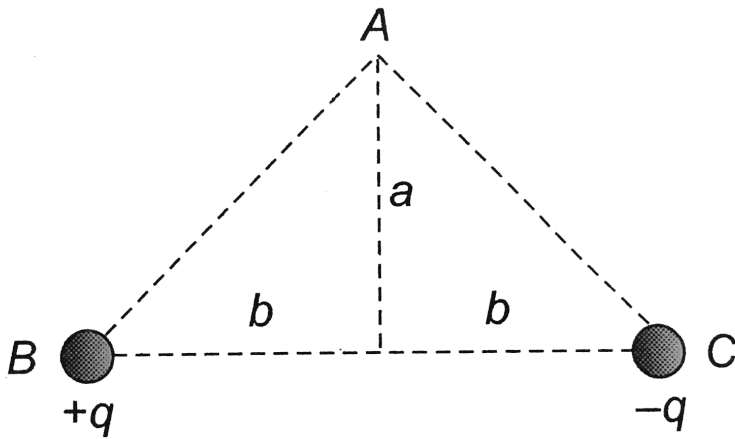

A.  $\frac{1}{4\pi\epsilon_0} \cdot \frac{2q}{\sqrt{a^2 + b^2}}$

B. zero

C.  $\frac{1}{4\pi\epsilon_0} \cdot \frac{q}{\sqrt{a^2 + b^2}}$

D.  $\frac{1}{4\pi\epsilon_0} \cdot \frac{-q}{\sqrt{a^2 + b^2}}$

**Answer: B**



**Watch Video Solution**

9. In the rectangle, shown below, the two corners have charges  $q_1 = -5\mu\text{C}$  and  $q_2 = +2.0\mu\text{C}$ . The work done in moving a charge  $+3.0\mu\text{C}$  from  $B \rightarrow A$  is (take  $1/44\pi\epsilon_0 = 10^{10}\text{N} \cdot \text{m}^2/\text{C}^2$ )

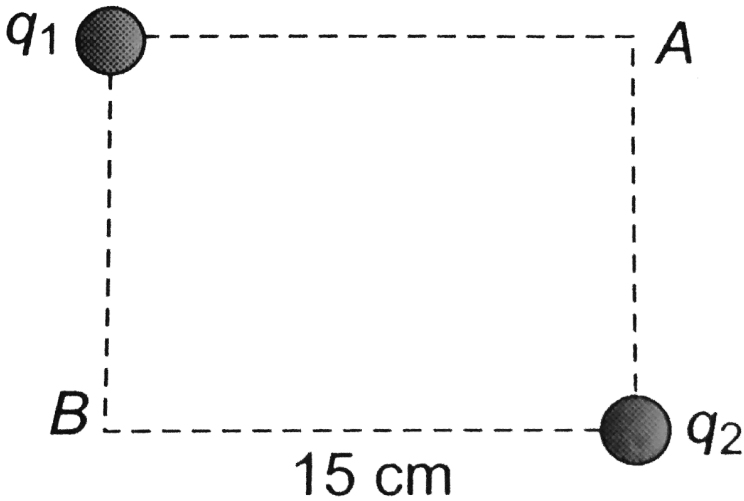

- A. 2.8 J
- B. 3.5 J
- C. 4.5 J
- D. 5.5 J

**Answer: A**

 [Watch Video Solution](#)

10. Two point charges  $-q$  and  $+q$  are located at points  $(0, 0 - a)$  and  $(0, 0, a)$  respectively. The electric potential at point  $(0, 0, z)$  is ( $Z > a$ )

A.  $\frac{qa}{4\pi_0 z^2}$

B.  $\frac{q}{4\pi\epsilon_0 a}$

C.  $\frac{2qa}{4\pi\epsilon_0(z^2 - a^2)}$

D.  $\frac{2qa}{4\pi\epsilon_0(z^2 + z^2)}$

**Answer: C**

 [Watch Video Solution](#)

11. Two plates are  $2\text{cm}$  apart, a potential difference of  $10\text{ volt}$  is applied between them, the electric field between the plates is

A.  $20\text{NC}^{-1}$

B.  $500\text{NC}^{-1}$

C.  $5\text{NC}^{-1}$

D.  $250\text{NC}^{-1}$

**Answer: B**



[Watch Video Solution](#)

12. At a certain distance from a point charge, the field intensity is  $500\text{V}/\text{m}$  and the potential is  $-3000\text{V}$ . The distance to the charge and the magnitude of the charge respectively are

A.  $6\text{ m}$

B. 12 m

C. 36 m

D. 144 m

**Answer: A**



**Watch Video Solution**

**13.** Two charges of  $4\mu C$  each are placed at the corners  $A$  and  $B$  of an equilateral triangle of side length  $0.2m$  in air. The

electric potential at  $C$  is  $\left[ \frac{1}{4\pi\epsilon_0} = 9 \times 10^9 \frac{N - m^2}{C^2} \right]$

A.  $9 \times 10^4 V$

B.  $18 \times 10^4 V$

C.  $36 \times 10^4 V$

D.  $36 \times 10^{-4} V$

**Answer: C**



**Watch Video Solution**

**14.** The electric potential  $V$  at any point  $(x, y, z)$ , all in meters in space is given by  $V = 4x^2$  volt. The electric field at the point  $(1, 0, 2)$  in volt//meter is

- A. 8 along negative X-axis
- B. 8 along positive X-axis
- C. 16 along negative X-axis
- D. 16 along positive Z-axis

**Answer: A**



**Watch Video Solution**

15. The electric potential  $V$  is given as a function of distance  $x$  (metre) by  $V = (5x^2 + 10x - 9)$  volt. Value of electric field at  $x = 1$  is

A.  $-20\text{Vm}^{-1}$

B.  $6\text{Vm}^{-1}$

C.  $11\text{Vm}^{-1}$

D.  $-23\text{Vm}^{-1}$

**Answer: A**



**Watch Video Solution**

## Check point 2.2

1. The work done to move a charge along an equipotential from  $A$  to  $B$



A. cannot be defined as  $-\int_A^B E \cdot dl$

B. must be defined as  $-\int_A^B E \cdot dl$

C. is zero

D. can have a non-zero value

**Answer: C**



[Watch Video Solution](#)

2. There is a uniform electric field of intensity  $E$  which is as shown.

How many labelled points have the same electric potential as the

fully shaded point ?



A. 2

B. 3

C. 8

D. 11

**Answer: B**



[View Text Solution](#)

3. The electric potential at the surface of an atomic nucleus ( $Z = 50$ ) of radius  $9.0 \times 10^{-13} \text{ cm}$  is

A. 80 V

B.  $8 \times 10^6 \text{ V}$

C. 9 V

D.  $9 \times 10 \text{ V}$

**Answer: B**



[Watch Video Solution](#)

4. A hollow metal sphere of radius  $5\text{cm}$  is charged so that the potential on its surface is  $10\text{V}$ . The potential at the centre of the sphere is

A.  $0\text{V}$

B.  $10\text{V}$

C. same as at point  $5\text{cm}$  away from the surface

D. same as at point  $25\text{cm}$  away from the surface

**Answer: B**



[Watch Video Solution](#)

5. Two charged spheres of radii  $R_1$  and  $R_2$  having equal surface charge density. The ratio of their potential is

A.  $R_1 / R_2$

B.  $R_2 / R_1$

C.  $(R_1 / R_2)^2$

D.  $(R_2 / R_1)^2$

**Answer: A**



**Watch Video Solution**

6. The radii of two concentric spherical conducting shells are  $r_1$  and  $r_2$  ( $> r_1$ ). The charge on the outer shell is  $q$ . The charge on the inner shell which is connected to the earth is

A.  $q \left( \frac{r_2}{r_1} \right)$

B.  $q^2 \left( \frac{r_1}{r_2} \right)$

C.  $-q(r_1 / r_2)$

D.  $q^2 \left( \frac{r_2}{r_1} \right)$

**Answer: C**



**Watch Video Solution**

7. If a charged spherical conductor of radius  $10\text{cm}$  has potential  $V$  at a point distant  $5\text{cm}$  from its centre, then the potential at a point distant  $15\text{cm}$  from the centre will be

A.  $\frac{1}{3}V$

B.  $\frac{2}{3}V$

C.  $\frac{3}{2}V$

D.  $3V$

**Answer: B**



**Watch Video Solution**

8. A hollow conducting sphere of radius  $R$  has a charge  $(+Q)$  on its surface. What is the electric potential within the sphere at a distance  $r = \frac{R}{3}$  from its centre ?

A. Zero

B.  $\frac{1}{4\pi\epsilon_0} \frac{Q}{r}$

C.  $\frac{1}{4\pi\epsilon_0} \frac{Q}{R}$

D.  $\frac{1}{4\pi\epsilon_0} \frac{Q}{r^2}$

**Answer: C**



**Watch Video Solution**

9. A spherical conductor of radius  $2m$  is charged to a potential of  $120V$ . It is now placed inside another hollow spherical conductor of radius  $6m$ . Calculate the potential to which the bigger sphere would be raised

A. 20 V

B. 60 V

C. 80 V

D. 40 V

**Answer: D**



[Watch Video Solution](#)

10. Three concentric spherical shells have radii  $a, b$  and  $c$  ( $a < b < c$ ) and have surface charge densities  $\sigma$ ,  $-\sigma$  and  $\sigma$  respectively. If  $V_A, V_B$  and  $V_C$  denote the potentials of the three shells, then for  $c = a + b$ , we have

A.  $V_C = V_A \neq V_B$

B.  $V_C = V_B \neq V_A$

C.  $V_C \neq V_B \neq V_A$

$$D. V_C = V_B = V_A$$

**Answer: A**

 [Watch Video Solution](#)

**11.** The electrostatic potential of a uniformly charged thin spherical shell of charge  $Q$  and radius  $R$  at a distance  $r$  from the centre

A.  $\frac{Q}{4\pi\epsilon_0 r}$  for points outside and  $\frac{Q}{4\pi\epsilon_0 R}$  for points inside the

shell

B.  $\frac{Q}{4\pi\epsilon_0 r}$  for both points inside and outside the shell

C. zero for points outside and  $\frac{Q}{4\pi\epsilon_0 r}$  for points inside the shell

D. zero for both points inside and outside the shell

**Answer: A**

 [Watch Video Solution](#)



12. The diameter of a hollow metallic sphere is 60 cm and the sphere carries a charge of  $500\mu C$ . The potential at a distance of 100cm from the centre of the sphere will be

A.  $6 \times 10^7 V$

B.  $7 \times 10^6 V$

C.  $4.5 \times 10^6 V$

D.  $5 \times 10^6 V$

**Answer: C**



**Watch Video Solution**

13. Obtain the energy in joule acquired by an electron beam when accelerated through a potential difference of 2000 V. How much

speed will the electron gain ?

A.  $\frac{8}{3} \times 10^7 \text{ m/s}$

B.  $\frac{7}{3} \times 10^7 \text{ m/s}$

C.  $\frac{5}{3} \times 10^7 \text{ m/s}$

D.  $\frac{2}{3} \times 10^7 \text{ m/s}$

**Answer: A**



**Watch Video Solution**

**14.** A particle  $A$  has charge  $+q$  and a particle  $B$  has charge  $+4q$  with each of them having the same mass  $m$ . When allowed to fall from rest through the same electric potential difference, the ratio of their speed  $\frac{v_A}{v_B}$  will become

A. 2:1

B. 1:2

C. 1:4

D. 4:1

**Answer: A**



**Watch Video Solution**

15. What potential difference must be applied to produce an electric field that can acceleration an electric to one length the velocity of light ?

A. 1352 V

B. 2511 V

C. 2531 V

D. 3521 V

**Answer: C**



**Watch Video Solution**

### Check point 2.3

1. When a positive  $q$  charge is taken from lower potential to a higher potential point, then its potential energy will

- A. decrease
- B. increase
- C. remains changed
- D. become zero

**Answer: B**



**Watch Video Solution**

2. When one electron is taken towards the other electron, then the electric potential energy of the system

- A. decrease
- B. increase
- C. remains changed
- D. become zero

**Answer: B**

 [Watch Video Solution](#)

3. Two positive point charges of  $12\mu C$  and  $8\mu C$  are  $10cm$  apart. The work done in bringing them  $4cm$  closer is

- A. 5.8 J
- B. 5.8 eV

C. 13 J

D. 13 eV

Answer: C

 Watch Video Solution

4. In the figure, a proton moves a distance  $d$  in a uniform electric  $\vec{E}$  as shown in the figure. Does the electric field do a positive or negative work on the proton? Does the electric potential energy of the proton increase or decrease?

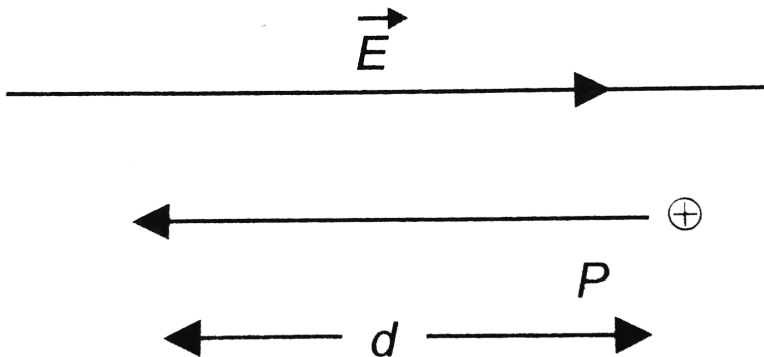

A. Negative, increase

B. Positive, decrease

C. Negative, decrease

D. Positive increase

**Answer: A**



**Watch Video Solution**

5. The electrostatic potential energy between proton and electron separated by a distance  $1 \text{ \AA}$  is

A.  $13.6 \text{ eV}$

B.  $27.2 \text{ eV}$

C.  $-14.4 \text{ eV}$

D.  $1.44 \text{ eV}$

**Answer: C**

 **Watch Video Solution**

**6. Identify the work statement**

- A. The electrical potential energy of a system of two protons shall increase if the separation between the two is decreased
- B. The electrical potential energy of a proton-electron system will increase if the separation between the two is decreased
- C. The electrical potential energy of a proton-electron system will increase if the separation between the two is increased
- D. The electrical potential energy of a system of two electrons shall increase if the separation between the two is decreased.

**Answer: C**





[View Text Solution](#)

7. Two positive point charges of 12 and 5 microcoulombs, are placed 10 cm apart in air. The work needed to bring them 4 cm closer is

A. 2.4 J

B. 3.6 J

C. 4.8 J

D. 6.0 J

**Answer: B**



[Watch Video Solution](#)

8. Three identical charges each of  $2\mu C$  are placed at the vertices of a triangle ABC as shown in the figure

If  $AB + AC = 12\text{cm}$  and  $AB \cdot AC = 32\text{cm}^2$ , the potential energy of the charge at A is



A. 1.53 J

B. 5.31 J

C. 3.15 J

D. 1.35 J

**Answer: D**

 [Watch Video Solution](#)

9. If 3 charges are placed at the vertices of equilateral triangle of charge 'q' each. What is the net potential energy, if the side of equilateral  $\Delta$  is  $l\text{cm}$  ?

A.  $\frac{1}{4\pi\epsilon_0} \frac{q^2}{l}$

B.  $\frac{1}{4\pi\epsilon_0} \frac{2q^2}{l}$

C.  $\frac{1}{4\pi\epsilon_0} \frac{3q^2}{l}$

D.  $\frac{1}{4\pi\epsilon_0} \frac{4q^2}{l}$

**Answer: C**



**Watch Video Solution**

**10.** Three charges  $Q$ ,  $(+q)$  and  $(+q)$  are placed at the vertices of an equilateral triangle of side  $l$  as shown in the figure. It the net

electrostatic energy of the system is zero, then  $Q$  is equal to

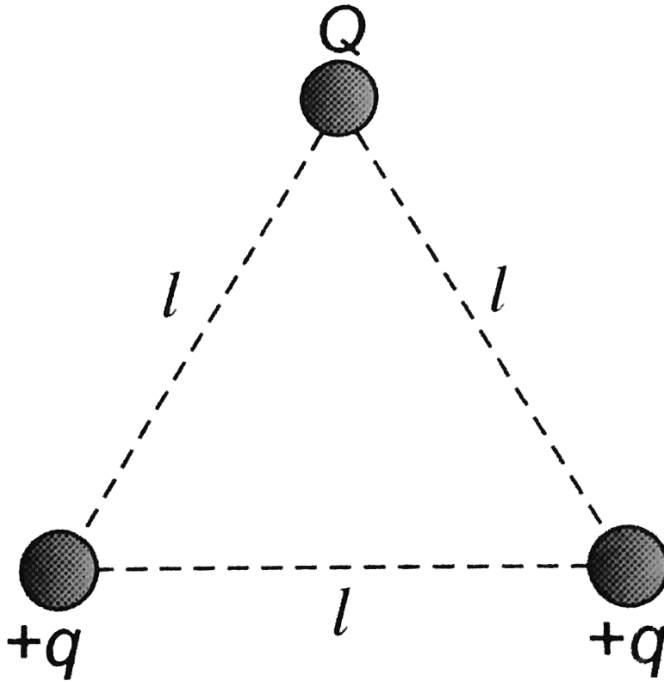

A.  $\left(-\frac{q}{2}\right)$

B.  $(-q)$

C.  $(+q)$

D. zero

**Answer: A**



**Watch Video Solution**

11. If identical charges ( $-q$ ) are placed at each corner of a cube of side  $b$ , then electric potential energy of charge ( $+q$ ) which is placed at centre of the cube will be

A.  $\frac{8\sqrt{2}q^2}{4\pi\epsilon_0 b}$

B.  $\frac{-8\sqrt{2}q^2}{\pi\epsilon_0 b}$

C.  $\frac{-4\sqrt{2}q^2}{\pi\epsilon_0 b}$

D.  $\frac{-4q^2}{\sqrt{3}\pi\epsilon_0 b}$

**Answer: D**



**Watch Video Solution**

12. Two charges  $q_1$  and  $q_2$  are placed  $30\text{cm}$  apart, as shown in the figure. A third charge  $q_3$  is moved along the arc of a circle of radius

40 cm from  $C$  to  $D$ . The change in the potential energy of the

system is  $\frac{q_3}{4\pi\epsilon_0} k$ , where  $k$  is

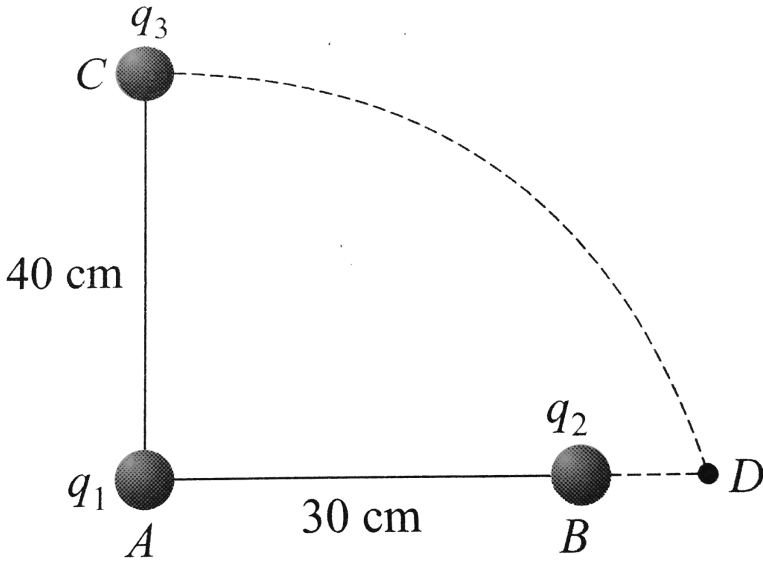

A.  $8q_2$

B.  $8q_1$

C.  $6q_2$

D.  $6q_1$

**Answer: A**

 [Watch Video Solution](#)

13. For a dipole  $q = 2 \times 10^{-6} C$  and  $d = 0.01m$ . Calculate the maximum torque for this dipole if  $E = 5 \times 10^5 N/C$

A.  $1 \times 10^{-3} N/m$

B.  $10 \times 10^{-3} N/m$

C.  $10 \times 10^{-3} N/m$

D.  $1 \times 10^2 N/m$

**Answer: C**



**Watch Video Solution**

14. A molecule with a dipole moment  $p$  is placed in an electric field of strength  $E$ . Initially the dipole is aligned parallel to the field. If the dipole is to be rotated to be anti-parallel to the field, the work required to be done by an external agency is

A.  $-2pE$

B.  $-pE$

C.  $pE$

D.  $2pE$

**Answer: D**



[Watch Video Solution](#)

**15.** Three points charges of  $1C$ ,  $2C$  and  $3C$  are placed at the corners of an equilateral triangle of side  $100$  cm. Find the work done to move these charges to the corners of a similar equilateral triangle of side  $50$  cm.

A.  $9.9 \times 10^{10} J$

B.  $9.9 \times 10^9 J$

C.  $52 \times 10^{10} J$



D.  $5.9 \times 10^9 J$

**Answer: A**



**Watch Video Solution**

## Check point 2.4

1. Identify the false statement

- A. Electric field is zero inside the conductor and just outside, it is normal to the surface
- B. Electric field is zero in the cavity of a hollow charged conductor
- C. A polar dielectric is one in which is having a net dipole moment zero in the absence of electric field

D.  $H_2$ ,  $N_2$ ,  $O_2$ ,  $CO_2$  and  $CH_4$  are examples of polar dielectric

**Answer: D**

 [Watch Video Solution](#)

2. Eight drops of mercury of equal radii possessing equal charges combine to form a big drop. Then the capacitance of bigger drop compared to each individual small drop is

A. 8 times

B. 4 times

C. 2 times

D. 32 times

**Answer: C**

 [Watch Video Solution](#)

3. The capacity of a parallel plate condenser depends upon

- A. the type of metal used the thickne of plates
- B. the potential applied across on the plates
- C. the separation between the plates
- D. all

**Answer: D**

 [Watch Video Solution](#)

4. As shown in the figure, a very thin sheet of aluminium is placed in between the plates of the condenser. Then the capacity

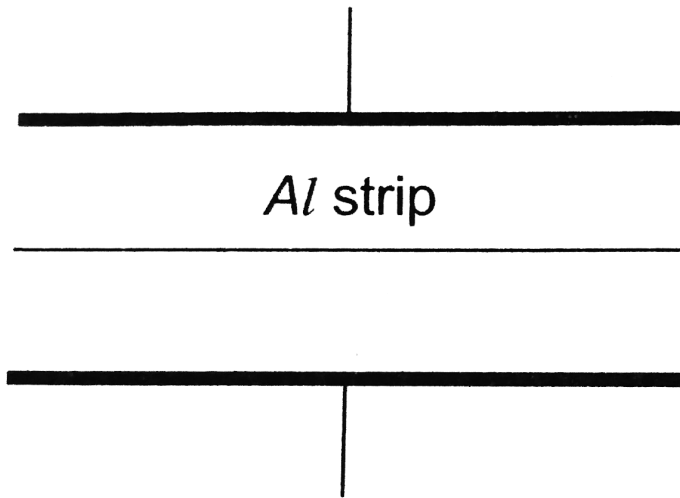

- A. will increase
- B. will decrease
- C. remains unchanged
- D. may increase or decrease

**Answer: C**

 [Watch Video Solution](#)

5. A lamp is connected in series with a capacitor. Predict your observations for dc and ac connections. What happens in each case if capacitance of the capacitor is reduced?

- A. lamp will not glow
- B. lamp will burst out
- C. lamp will glow normally
- D. None of these

**Answer: A**

 [Watch Video Solution](#)

6. The capacity of a spherical conductor is

- A.  $\frac{R}{4\pi\epsilon_0}$
- B.  $\frac{4\pi\epsilon_0}{R}$

C.  $4\pi\epsilon_0 R$

D.  $4\pi\epsilon_0 R^2$

**Answer: C**

 [Watch Video Solution](#)

7. The potentials of the two plates of capacitor are  $+10V$  and  $-10V$ . The charge on one of the plate is  $40C$ . The capacitance of the capacitor is

A. 2 F

B. 4 F

C. 0.5 F

D. 0.25 F

**Answer: A**

 [Watch Video Solution](#)

8. The earth has volume  $V$  and surface area  $A$  then capacitance would be

A.  $4\pi\epsilon_0 \frac{A}{V}$

B.  $2\pi\epsilon_0 \frac{A}{V}$

C.  $12\pi\epsilon_0 \frac{V}{A}$

D.  $12\pi\epsilon_0 \frac{A}{V}$

**Answer: C**

 [Watch Video Solution](#)

9. If the circumference of a sphere is 2 m, then capacitance of sphere in water would be

A. 2700 pF

B. 2760 pF

C. 2780 pF

D. 2800 pF

**Answer: D**



**Watch Video Solution**

**10.** The capacitance of a parallel plate capacitor is  $12\mu F$ . If the distance between the plates is doubled and area is halved, then new capacitance will be

A.  $8\mu F$

B.  $6\mu F$

C.  $4\mu F$



D.  $3\mu F$

**Answer: D**

 [Watch Video Solution](#)

11. A parallel plate condenser has a capacitance  $50\mu F$  in air and  $100\mu F$  when immersed in an oil. The dielectric constant  $k$  of the oil is

A. 0.45

B. 0.55

C. 1.10

D. 2.20

**Answer: D**

 [Watch Video Solution](#)

12. The  $500\mu F$  capacitor is charged at a steady rate of  $100\mu C / s$ . The potential difference across the capacitor will be 10 V after an interval of

- A. 5 s
- B. 25 s
- C. 20 s
- D. 50 s

**Answer: D**

 [Watch Video Solution](#)

13. There is an air filled 1pF parallel plate capacitor. When the plate separation is doubled and the space is filled with wax, the capacitance increases to 2pF. The dielectric constant of wax is

A. 2

B. 4

C. 6

D. 8

**Answer: B**



[Watch Video Solution](#)

14. A parallel plate capacitor with air between the plates has capacitance of  $9\text{pF}$ . The separation between its plates is 'd'. The space between the plates is now filled with two dielectrics. One of the dielectrics has dielectric constant  $k_1 = 3$  and thickness  $\frac{d}{3}$  while the other one has dielectric constant  $k_2 = 6$  and thickness  $\frac{2d}{3}$ . Capacitance of the capacitor is now

A. 45 pF

B. 40.5 pF

C. 20.25 pF

D. 1.8 pF

**Answer: B**



**Watch Video Solution**

15. Two parallel plate of area  $A$  are separated by two different dielectrics as shown in figure. The net capacitance is



A.  $\frac{4\epsilon_0 A}{3d}$

B.  $\frac{3\epsilon_0 A}{R}$

C.  $\frac{2\epsilon_0 A}{d}$

D.  $\frac{\epsilon_0 A}{d}$

Answer: A



View Text Solution

## Check point 2.5

1. Three capacitors each of capacitance  $C$  and of breakdown voltage  $V$  are joined in series. The capacitance and breakdown voltage of the combination will be

A.  $\frac{C}{3}, \frac{V}{3}$

B.  $3C, \frac{V}{3}$

C.  $\frac{C}{3}, 3V$

D.  $3C, 3V$

Answer: C



Watch Video Solution

2. In given circuit when switch S has been closed, then charge on capacitor A and B respectively



A.  $3q, 6q$

B.  $6q, 3q$

C.  $4.5q, 4.5q$

D.  $5q, 4q$

**Answer: B**



[View Text Solution](#)

3. Three condensers each of capacitance  $2F$  are put in series. The resultant capacitance is

A.  $6F$

B.  $\frac{3}{2}F$

C.  $\frac{2}{3}F$

D.  $5F$

**Answer: C**



**Watch Video Solution**

4. Two capacitors of capacitance  $2\mu F$  and  $3\mu F$  are joined in series. Outer plate of first capacitor is at 1000 volt and outer plate of second capacitor is earthed (grounded). Now the potential on inner plate of each capacitor will be

A. 700 V

B. 200 V

C. 600 V

D. 400 V

**Answer: D**

 [Watch Video Solution](#)

5. A series combination of three capacitors of capacities  $1\mu F$ ,  $2\mu F$  and  $8\mu F$  is connected to a battery of e.m.f.  $13\text{vo} < .$  The potential difference across the plates of  $2\mu F$  capacitor will be

A. 1 V

B. 8 V

C. 4 V

D.  $\frac{13}{3} V$

**Answer: C**

 [Watch Video Solution](#)



6. A parallel plate capacitor is made by stacking  $n$  equally spaced plates connected alternatively. If the capacitance between any two adjacent plates is 'C' then the resultant capacitance is

A.  $C$

B.  $nC$

C.  $(n - 1)C$

D.  $(n + 1)C$

**Answer: C**



**Watch Video Solution**

7. Four capacitors of equal capacitance have an equivalent capacitance  $C_1$  when connected in series and an equivalent capacitance  $C_2$  when connected in parallel. The ratio  $\frac{C_1}{C_2}$  is

A.  $\frac{1}{4}$

B.  $\frac{1}{16}$

C.  $\frac{1}{8}$

D.  $\frac{1}{12}$

**Answer: B**



**Watch Video Solution**

8. Three capacitors of capacitance  $3\mu F$  are connected in a circuit.

Then, their maximum and minimum capacitance will be

A.  $9\mu F, 1\mu F$

B.  $8\mu F, 2\mu F$

C.  $9\mu F, 0, \mu C$

D.  $3\mu F, 2\mu F$

**Answer: A**



**Watch Video Solution**

9. Three capacitors each of capacity  $4\mu F$  are to be connected in such a way that the effective capacitance is  $6\mu F$ . This can be done by

- A. connecting them in parallel
- B. connecting two in series and one in parallel
- C. connecting two in parallel and one in series
- D. connecting all of them in series

**Answer: B**



**Watch Video Solution**

10. In the figure shown, the effective capacitance between the points  $A$  and  $B$ , if each has capacitance  $C$ , is

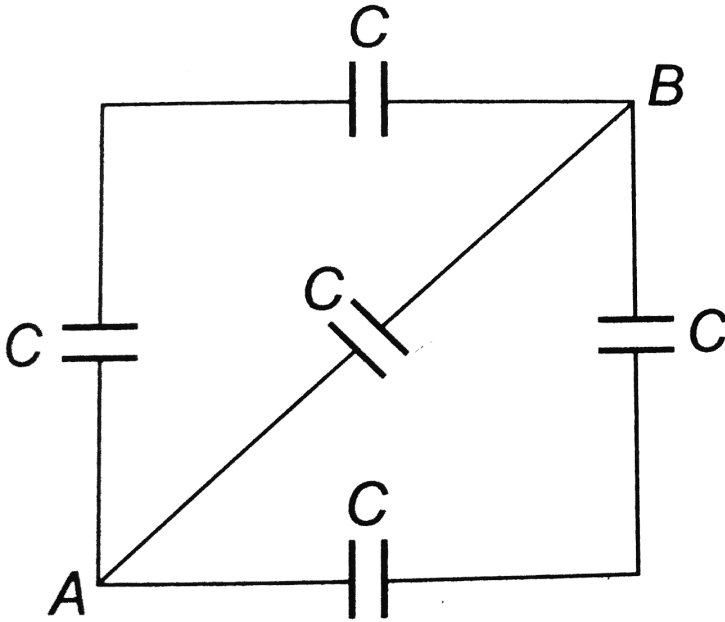

- A.  $2C$
- B.  $C/5$
- C.  $5C$
- D.  $C/2$

**Answer: A**

11. Four equal capacitors, each of capacity  $C$ , are arranged as shown. The effective capacitance between  $A$  and  $B$  is

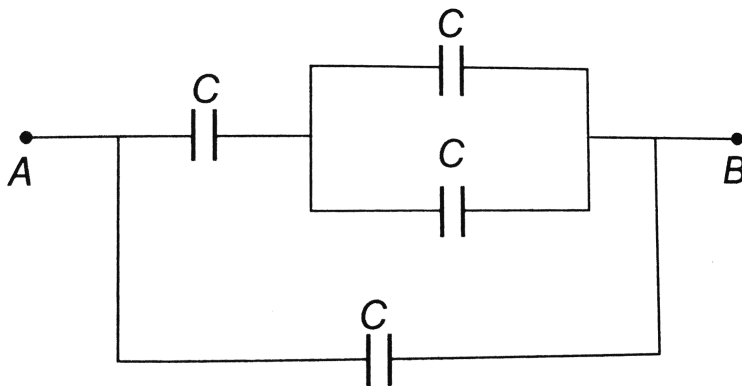

A.  $\frac{5}{8}C$

B.  $\frac{3}{5}C$

C.  $\frac{5}{3}C$

D.  $C$

**Answer: C**

12. In the circuit as shown in the figure the effective capacitance between  $A$  and  $B$  is

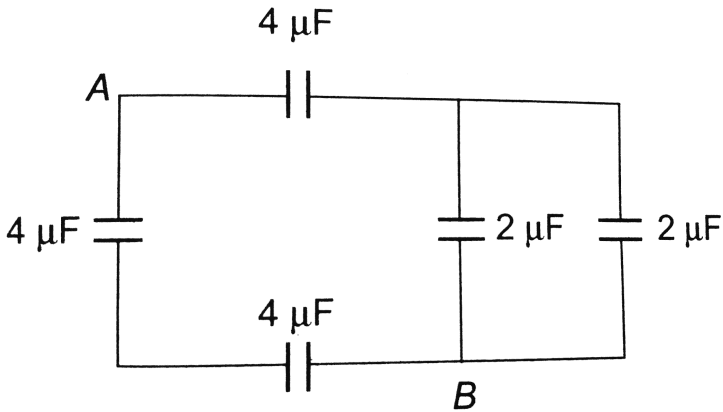

- A.  $3\ \mu\text{F}$
- B.  $2\ \mu\text{F}$
- C.  $4\ \mu\text{F}$
- D.  $8\ \mu\text{F}$

Answer: C

 Watch Video Solution

13. The charge on any of the  $2\mu F$  capacitors and  $1\mu F$  capacitor will be given respectively (in  $\mu C$ ) as

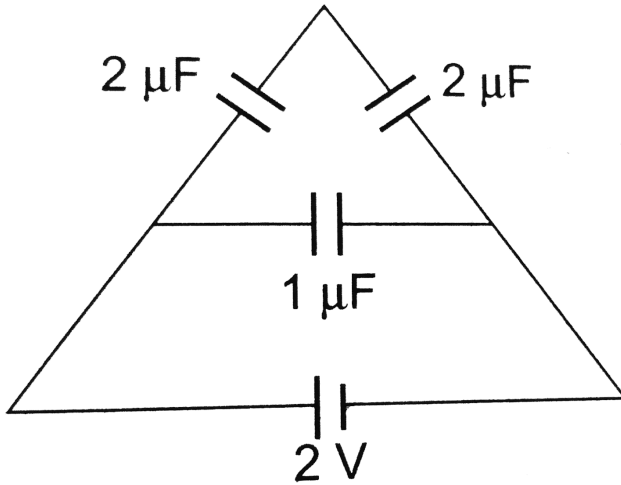

- A. 1, 2
- B. 2, 1
- C. 1, 1
- D. 2, 2

Answer: D



14. Equivalent capacitance between  $A$  and  $B$  is

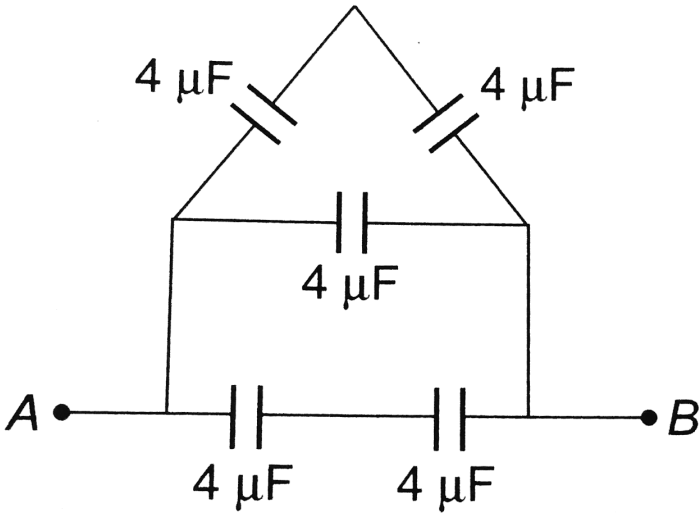

A.  $8\ \mu\text{F}$

B.  $6\ \mu\text{F}$

C.  $26\ \mu\text{F}$

D.  $\frac{10}{3}\ \mu\text{F}$

Answer: A





Watch Video Solution

15. The energy stored in a capacitor of capacitance  $100\mu F$  is 50 J. Its potential difference is

- A. 50 V
- B. 500 v
- C. 1000 V
- D. 1500 V

Answer: C



Watch Video Solution

16. The potential energy of a charged parallel plate capacitor is  $U_0$ . If a slab of dielectric constant  $K$  is inserted between the plates,

then the new potential energy will be

A.  $\frac{U_0}{K}$

B.  $U_0 K^2$

C.  $\frac{U_0}{K^2}$

D.  $U_0^2$

**Answer: A**



[Watch Video Solution](#)

17. A series combination of  $n_1$  capacitors, each of value  $C_1$ , is charged by a source of potential difference  $4V$ . When another parallel combination of  $n_2$  capacitors, each of value  $C_2$ , is charged by a source of potential difference  $V$ , it has same (total) energy stored in it, as the first combination has. the value of  $C_2$ , in terms of  $C_1$ , is then

A.  $\frac{16C_1}{n_1n_2}$

B.  $\frac{2C_1}{n_1n_2}$

C.  $16\frac{n_2}{n_1}C_1$

D.  $2\frac{n_2}{n_1}C_1$

**Answer: A**



**Watch Video Solution**

**18.** If the charge on a capacitor is increased by  $2C$ , then the energy stored in it increases by 21 %. The original charge on the capacitor is

A. 10 C

B. 20 C

C. 30 C

D. 40 C

**Answer: B**

 [Watch Video Solution](#)

**19.** A capacitor of capacitance value  $1\mu F$  is charged to 30 V and the battery is then disconnected. If it is connected across a  $2\mu F$  capacitor, then the energy lost by the system is

A.  $300\mu J$

B.  $450\mu J$

C.  $225\mu J$

D.  $150\mu F$

**Answer: A**

 [Watch Video Solution](#)

20. A parallel plate capacitor is charged to a potential difference of 50 volts. It is then discharged through a resistance for 2 seconds and its potential drops by 10 volts. Calculate the fraction of energy stored in the capacitance.

A. 0.14

B. 0.25

C. 0.50

D. 0.64

**Answer: D**



[Watch Video Solution](#)

**(A) Chapter exercises**

1. Angle between equipotential surface and lines of force is

A. zero

B.  $180^\circ$

C.  $90^\circ$

D.  $45^\circ$

**Answer: C**



[Watch Video Solution](#)

2. At a certain distance from a point charge, the field intensity is  $500V/m$  and the potential is  $-3000V$ . The distance to the charge and the magnitude of the charge respectively are

A. 6 m

B. 12 m

C. 36 m

D. 144 m

**Answer: A**



**Watch Video Solution**

3. A charge of  $5C$  is given a displacement of  $0.5m$ . The work done in the process is  $10J$ . The potential difference between the two points will be

A. 2 V

B. 0.25 V

C. 1 V

D. 25 V

**Answer: A**

 [Watch Video Solution](#)

4. An electron enters in high potential region  $V_2$  from lower potential region  $V_1$  then its velocity

- A. will increase
- B. will change in direction but not in magnitude
- C. will not change in direction of field
- D. will no change in direction perpendicular to field

**Answer: A:D**

 [Watch Video Solution](#)

5. When the separation between two charges is increased, the electric potential energy of the charges



- A. increases
- B. decreases
- C. remains the same
- D. may increase or decrease

**Answer: D**



**Watch Video Solution**

**6.** If a positive charge is shifted from a low - potential region to a high- potential region, the electric potential energy

- A. increases
- B. decreases
- C. remains the same
- D. may increase or decrease

**Answer: A**

 [Watch Video Solution](#)

7. The work done in carrying a charge of  $5\mu\text{C}$  from a point  $A$  to a point  $B$  in an electric field is  $10\text{mJ}$ . The potential difference  $(V_B - V_A)$  is then

A.  $+2\text{kV}$

B.  $-2\text{kV}$

C.  $+200\text{kV}$

D.  $-200\text{kV}$

**Answer: A**

 [Watch Video Solution](#)

8. The unit of electric permittivity is

A. volt/m<sup>2</sup>

B. joule/C

C. farad/m

D. henry/m

**Answer: C**



**Watch Video Solution**

9. The capacitance of a capacitor does not depend upon

A. the medium between the plates

B. the size of the plates

C. the charges on the plates

D. the separation between the plates

**Answer: C**

 [Watch Video Solution](#)

**10.** In a charged capacitor, the energy resides in

- A. the positive charges
- B. Both the positive and negative charges
- C. the field between the plates
- D. around the edge of the capacitor plate

**Answer: C**

 [Watch Video Solution](#)

**11.** Which of the following is not true ?

- A. For a point charge, the electrostatic potential varies as  $1/r$
- B. For a dipole, the potential depends on the position vector and dipole moment vector
- C. The electric dipole potential varies as  $1/r$  at large distance
- D. For a point charge, the electrostatic field varies as  $1/r^2$

**Answer: C**

 [Watch Video Solution](#)

**12.** The energy stored in the condenser is

- A. kinetic energy
- B. potential energy
- C. elastic energy
- D. magnetic energy

**Answer: B**

 [Watch Video Solution](#)

13. The potential energy of a charged parallel plate capacitor is  $U_0$ . If a slab of dielectric constant  $K$  is inserted between the plates, then the new potential energy will be

A.  $\frac{U_0}{k}$

B.  $U_0 k^2$

C.  $\frac{U_0}{k^2}$

D.  $U_0^2$

**Answer: A**

 [Watch Video Solution](#)

14. A charge  $Q$  is placed at the origin. The electric potential due to this charge at a given point in space is  $v$ . The work done by an external force in bringing another charge  $q$  from infinity up to the point is

A.  $\frac{V}{q}$

B.  $Vq$

C.  $V + q$

D.  $V$

**Answer: B**



[Watch Video Solution](#)

15. The force between the plates of a parallel plate capacitor of capacitance  $C$  and distance of separation of the plates  $d$  with a potential difference  $V$  between the plates, is.

A.  $\frac{CV^2}{2d}$

B.  $\frac{C^2V^2}{2d^2}$

C.  $\frac{C^2V^2}{d^2}$

D.  $\frac{V^2d}{C}$

**Answer: A**



**Watch Video Solution**

**16.** An electric dipole of moment  $p$  is placed in a uniform electric field

$E$ . Then,

(i) the torque on the dipole is  $p \times E$

(ii) the potential energy of the system is  $p \cdot E$

(iii) the resultant force on the dipole is zero.

A. (i),(ii) and (iii) are correct

B. (i) and (iii) are correct and (ii) is wrong



C. Only (i) is correct

D. (i) and (ii) are correct and (iii) is wrong

**Answer: B**



[View Text Solution](#)

17. A positively charged particle is released from rest in a uniform electric field. The electric potential energy of the charge.

A. remains a constant because the electric field is uniform

B. increases because the charge moves along the electric field

C. decreases because the charge moves along the electric field

D. decrease because the charge moves opposite to th electric field

**Answer: C**



[Watch Video Solution](#)

18. Identify the false statement

- A. Inside a charged or neutral conductor electrostatic field is zero
- B. The electrostatic field at the surface of the charged conductor must be tangential to the surface at any point
- C. There is no net charge at any point inside the conductor
- D. Electrostatic potential is constant throughout the volume of the conductor

**Answer: D**



[Watch Video Solution](#)

19. Equipotentials at a great distance from a collection of charges whose total sum is not zero are approximately

- A. spheres
- B. planes
- C. paraboloids
- D. ellipsoids

**Answer: A**



[Watch Video Solution](#)

20. An electron enters in high potential region  $V_2$  from lower potential region  $V_1$ , then its velocity

- A. will increase
- B. will change in direction but not in magnitude

C. no change in direction of field

D. no change in direction perpendicular to field

**Answer: A**



[Watch Video Solution](#)

21. The capacitance of a metallic sphere is  $1\mu F$ , if its

A. 9 km

B. 10 m

C. 1.11 m

D. 1.11 cm

**Answer: A**



[Watch Video Solution](#)

22. The unit of electric field is not equivalent to

A. N/C

B. J/C

C. V/m

D. J/C-m

**Answer: B**



[Watch Video Solution](#)

23. The electric potential  $V$  is given as a function of distance  $x$  (metre) by  $V = (5x^2 + 10x - 9)$  volt. Value of electric field at  $x = 1$  is

A.  $-20V/m$

B.  $6V/m$

C.  $11V/m$

D.  $-23V/m$

**Answer: A**

 [Watch Video Solution](#)

24. Potential at a point  $x$ -distance from the centre inside the conducting sphere of radius  $R$  and charged with charge  $Q$  is

A.  $\frac{1}{4\pi\epsilon_0} \frac{Q}{R}$

B.  $\frac{1}{4\pi\epsilon_0} \frac{Q}{x}$

C.  $\frac{1}{4\pi\epsilon_0} xQ$

D. zero

**Answer: A**

 [Watch Video Solution](#)

25. If a charged spherical conductor of radius 5 cm has potential  $V$  at a point distant 5 cm its centre, then the potential at a point distant 30 cm from the centre will be

A.  $\frac{1}{3}V$

B.  $\frac{1}{6}V$

C.  $\frac{3}{2}V$

D.  $3V$

**Answer: B**



**Watch Video Solution**

26. Two plates are at potentials  $-10V$  and  $+30V$ . If the separation between the plates be  $2\text{cm}$ . The electric field between them is

A. 2000 V/m

B. 1000 V/m

C. 500 V/m

D. 3000 V/m

**Answer: A**



**Watch Video Solution**

27. The potential at a point due to an electric dipole will be maximum and minimum when the angles between the axis of the dipole and the line joining the point to the dipole are respectively

A.  $90^\circ$  and  $180^\circ$

B.  $0^\circ$  and  $90^\circ$

C.  $90^\circ$  and  $0^\circ$



D.  $0^\circ$  and  $180^\circ$

**Answer: D**

 [Watch Video Solution](#)

**28.** An electric dipole when placed in a uniform electric field  $E$  will have minimum potential energy, if the positive direction of dipole moment makes the following angle with  $E$

A.  $\pi$

B.  $\pi/2$

C. zero

D.  $3\pi/2$

**Answer: C**

 [Watch Video Solution](#)

29. How much kinetic energy will be gained by an  $\alpha$  – particle in going from a point at  $70V$  to another point at  $50V$

- A. 40 eV
- B. 40 keV
- C. 40 MeV
- D. 0 eV

**Answer: A**

 [Watch Video Solution](#)

30. A charged particle of mass  $m$  and charge  $q$  is released from rest in an electric field of constant magnitude  $E$ . The kinetic energy of the particle after time  $t$  is

A.  $\frac{Eq^2m}{2t^2}$

B.  $\frac{2E^2t^2}{mq}$

C.  $\frac{E^2q^2t^2}{2m}$

D.  $\frac{Eqm}{2t}$

**Answer: C**



**Watch Video Solution**

**31.** Two positive point charges of  $12\mu C$  and  $8\mu C$  are  $10cm$  apart.

The work done in bringing them  $4cm$  closer is

A. 5.8 J

B. 5.8 eV

C. 13 J

D. 13 eV

**Answer: A**

 [Watch Video Solution](#)

**32.** The capacitance of the earth, viewed as a spherical conductor of radius 6408 km is

A.  $980\mu F$

B.  $1424\mu F$

C.  $712\mu F$

D.  $356\mu F$

**Answer: C**

 [Watch Video Solution](#)

33. A thin metal plate  $P$  is inserted between the plates of a parallel-plate capacitor of capacitance  $C$  in such a way that its edges touch the two plates (figure 31-Q2). The capacitance now becomes.

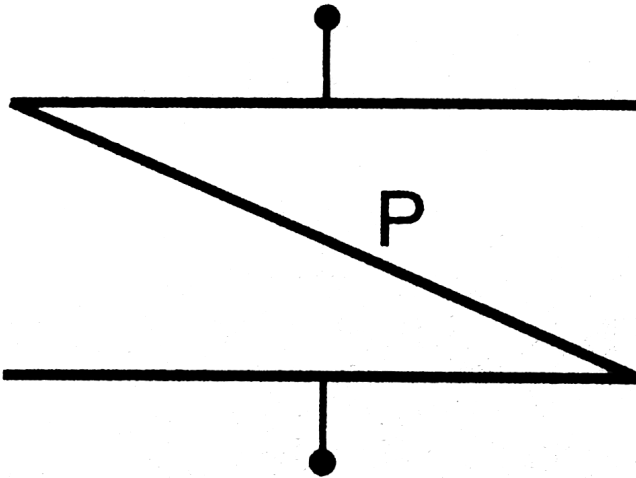

- A.  $C/2$
- B.  $2C$
- C. zero
- D.  $\infty$

Answer: D





[Watch Video Solution](#)

34. A capacitor of capacity  $C$  has charge  $Q$  and stored energy is  $W$ .  
if the charge is increased to  $2Q$ , then the stored energy will be

- A.  $2W$
- B.  $W/2$
- C.  $4W$
- D.  $W/4$

**Answer: C**



[Watch Video Solution](#)

35. A  $2\mu F$  capacitor is charged to  $100V$ , and then its plates are connected by a conducting wire. The heat produced is .

A. 1 J

B. 0.1 J

C. 0.01 J

D. 0.001 J

**Answer: C**



[Watch Video Solution](#)

**36.** If there are  $n$  capacitors in parallel connected to  $V$  volt source, then the energy stored is equal to

A.  $nCV^2$

B.  $\frac{1}{2}nCV^2$

C.  $\frac{CV^2}{n}$

D.  $\frac{1}{2n}CV^2$

**Answer: B**



**Watch Video Solution**

**37.** A variable condenser is permanently connected to a  $100V$  battery. If the capacity is charged from  $2\mu F$  to  $10\mu F$ , then change in energy is equal to

A.  $2 \times 10^{-2} J$

B.  $2.5 \times 10^{-2} J$

C.  $3.5 \times 10^{-2} J$

D.  $4 \times 10^{-2} J$

**Answer: D**



**Watch Video Solution**



38. Two condensers of capacity  $0.3\mu F$  and  $0.6\mu F$  respectively are connected in series. The combination is connected across a potential of 6 volts. The ratio of energies stored by the condensers will be

A.  $\frac{1}{2}$

B. 2

C.  $\frac{1}{4}$

D. 4

**Answer: B**



[Watch Video Solution](#)

39. A capacity of capacity  $C_1$  is charged up to  $V$  volt and then connected to an uncharged capacitor of capacity  $C_2$ . Then final potential difference across each will be

A.  $\frac{C_2}{C_1 + C_2} V$

B.  $\frac{C_1}{C_1 + C_2} V$

C.  $\frac{C_1 + C_2}{C_2}$

D.  $\frac{C_1 + C_2}{C_1} V$

**Answer: B**



**Watch Video Solution**

**40.** A capacitor is charged by using a battery which is then disconnected. A dielectric slab is then slipped between the plates, which results in

A. reduction of charges on the plates and increase of potential difference across the plates

- B. increase in the potential difference across the plates, reduction in stored energy, but no change in the charge on the plates
- C. decrease in the potential difference across that plates, reduction in stored energy, but no change in the charge on the plates.
- D. None of the above

**Answer: C**

 [Watch Video Solution](#)

**41.** A parallel plate air capacitor is charged to a potential difference of  $V$  volts. After disconnecting the charging battery the distance between the plates of the capacitor is increased using an insulating handle. As a result the potential difference between the plates

- A. decrease
- B. increases
- C. becomes zero
- D. does not change

 [Watch Video Solution](#)

**42.** Two concentric metallic spherical shells are given positive charges . Then

- A. the outer sphere is always at a higher potential
- B. the inner sphere is always at a higher potential
- C. Both the spheres are at the same potential
- D. no prediction can be made about their potentials unless the actual value of charges and radii are known

**Answer: B**



**Watch Video Solution**

**43.** Dielectric constant of pure water is 81. Its permittivity will be

A.  $7.16 \times 10^{-10}$  MKS units

B.  $8.86 \times 10^{-12}$  MKS units

C.  $1.02 \times 10^{13}$  MKS units

D. Cannot be calculated

**Answer: A**



**Watch Video Solution**

**44.** Two spherical conductors each of capacity  $C$  are charged to potential  $V$  and  $-V$ . These are then connected by means of a fine

wire. The loss of energy will be

A. zero

B.  $\frac{1}{2}CV^2$

C.  $CV^2$

D.  $2CV^2$

**Answer: C**



**Watch Video Solution**

**45.** Two spheres A and B of radius 4 cm and 6 cm are given charges of  $80\mu C$  and  $40\mu C$ , respectively. If they are connected by a fine wire, then the amount of charge flowing from one to the other is

A.  $20\mu C$  from A to B

B.  $20\mu C$  from B to A

C.  $32\mu C$  from B to A

D.  $32\mu C$  from A to B

**Answer: D**



**Watch Video Solution**

**46.** The electric potential difference between two parallel plates is  $2000V$ . If the plates are separated by  $2\text{ mm}$ , then what is the magnitude of electrostatic force on a charge of  $4 \times 10^{-6}C$  located midway between the plates ?

A.  $4\text{ N}$

B.  $6\text{ N}$

C.  $8\text{ N}$

D.  $1.5 \times 10^{-6}N$

**Answer: A**



**Watch Video Solution**

47. Two conducting spheres A and B of radii 4 cm and 2 cm carry charges of  $18 \times 10^{-8}$  statcoulomb and  $9 \times 10^{-8}$  statcoulomb respectively of positive electricity. When they are put in electrostatic contact, then the charge will

- A. not flow at all
- B. flow from A to B
- C. flow from B to A
- D. disappear

**Answer: A**



**Watch Video Solution**



48. The insulated spheres of radii  $R_1$  and  $R_2$  having charges  $Q_1$  and  $Q_2$  respectively are connected to each other. There is

- A. an increase in the energy of the system
- B. no change in the energy of the system
- C. always decrease in energy
- D. a decrease in energy of the system unless  $Q_1 R_2 = Q_2 R_1$

**Answer: D**

 [Watch Video Solution](#)

49. A small sphere is charged to a potential of 50 V and a big hollow sphere is charged to a potential of 100 V. Electricity will flow from the smaller sphere to the bigger one when

- A. the smaller one is placed inside the bigger one and connected by a wire
- B. bigger one placed by the side of the small one and connected by a wire
- C. Both are correct
- D. Both are wrong

**Answer: A**



**Watch Video Solution**

**50.** Two identical charges are placed at the two corners of an equilateral triangle. The potential energy of the system is  $U$ . The work done in bringing an identical charge from infinity to the third vertex is

A.  $U$

B.  $2U$

C.  $3U$

D.  $4U$

**Answer: B**



**Watch Video Solution**

**51.** Four electric charges  $+q$ ,  $+q$ ,  $-q$  and  $-q$  are placed at the corners of a square of side  $2L$  (see figure). The electric potential at

point  $A$ , mid-way between the two charges  $+q$  and  $+q$ , is

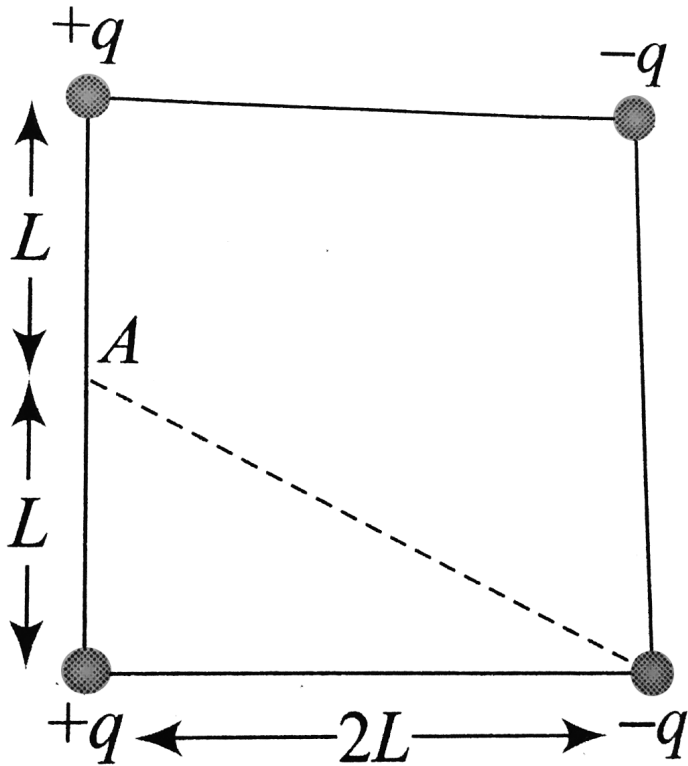

A.  $\frac{1}{4\pi\epsilon_0} \frac{2q}{L} \left( 1 + \frac{1}{\sqrt{5}} \right)$

B.  $\frac{1}{4\pi\epsilon_0} \frac{2q}{L} \left( 1 - \frac{1}{\sqrt{5}} \right)$

C. zero

D.  $\frac{1}{4\pi\epsilon_0} \frac{2q}{L} (1 + \sqrt{5})$

**Answer: B**

 [Watch Video Solution](#)

52. A hollow metal sphere of radius 10cm is charged such that the potential on its surface is 80 V. The potential at the centre of the sphere is

- A. 80 V
- B. 800 V
- C. 8 V
- D. zero

**Answer: A**

 [Watch Video Solution](#)

53. A parallel plate condenser has a uniform electric field  $E(V/m)$  in the space between the plates. If the distance between the plates is  $d(m)$  and area of each plate is  $A(m^2)$  the energy (joule) stored in the condenser is

A.  $\frac{1}{2}\epsilon_0 E^2$

B.  $\epsilon_0 E A d$

C.  $\frac{1}{2}\epsilon_0 E^2 A d$

D.  $E^2 A d / \epsilon_0$

**Answer: C**



**Watch Video Solution**

54. Charges  $5\mu C$  and  $10\mu C$  are placed 1 m apart. Work done to bring these charges at a distance 0.5 m from each other is  
( $k = 9 \times 10^9 SI$ )

A.  $9 \times 10^4 J$

B.  $18 \times 10^4 J$

C.  $45 \times 10^{-2} J$

D.  $9 \times 10^{-1} J$

**Answer: D**



**Watch Video Solution**

**55.** A particle of mass  $2 \times 10^{-3} \text{ kg}$ , charge  $4 \times 10^{-3} \text{ C}$  enters in an electric field of  $5V/m$ , then its kinetic energy after 10 s is

A. 0.1 J

B. 1 J

C. 10 J

D. 100 J

Answer: C

 [Watch Video Solution](#)

56. The ionisation potential of mercury is 10.39 V. How far an electron must travel in an electric field of  $1.5 \times 10^6 \text{ V/m}$  to gain sufficient energy to ionise mercury ?

A.  $\frac{10.39}{1.6 \times 10^{-19}} \text{ m}$

B.  $\frac{10.39}{2 \times 1.6 \times 10^{-19}} \text{ m}$

C.  $10.39 \times 1.6 \times 10^{-19} \text{ m}$

D.  $\frac{10.39}{1.5 \times 10^6} \text{ m}$

Answer: D

 [Watch Video Solution](#)



57.  $0.2F$  capacitor is charged to  $600V$  by a battery. On removing the battery it is connected with another parallel plate capacitor of  $1F$ . The potential decreases to

- A. 100 V
- B. 120 V
- C. 300 V
- D. 600 V

**Answer: A**

 [Watch Video Solution](#)

58. The work done in placing a charge of  $8 \times 10^{-18}$  coulomb on a condenser of capacity 100 micro-farad is

- A.  $16 \times 10^{-32} J$

B.  $31 \times 10^{-26} J$

C.  $4 \times 10^{-10} J$

D.  $32 \times 10^{-32} J$

**Answer: D**



**Watch Video Solution**

**59.** In a parallel plate capacitor, the separation between the plates is 3mm with air between them. Now a 1mm thick layer of a material of dielectric constant 2 is introduced between the plates due to which the capacity increases. In order to bring its capacity of the original value, the separation between the plates must be made-

A. 1.5 mm

B. 2.5 mm

C. 3.5 mm

D. 4.5 mm

**Answer: C**

 [Watch Video Solution](#)

**60.** The electric potential at any point  $x, y, z$  in metres is given by

$V = 3x^2$ . The electric field at a point  $(2, 0, 1)$  is

A.  $12 \text{ Vm}^{-1}$

B.  $-6 \text{ Vm}^{-1}$

C.  $6 \text{ Vm}^{-1}$

D.  $-12 \text{ Vm}^{-1}$

**Answer: D**

 [Watch Video Solution](#)

61. An electron of mass  $m$  and charge  $e$  is accelerated from rest through a potential difference  $V$  in vacuum. The final speed of the electron will be

A.  $V \sqrt{\frac{e}{m}}$

B.  $\sqrt{\frac{eV}{m}}$

C.  $\sqrt{\frac{2eV}{m}}$

D.  $\frac{2eV}{m}$

**Answer: C**



[Watch Video Solution](#)

62. If an electron moves from rest from a point at which potential is 50 volt to another point at which potential is 70 volt, then its kinetic energy in the final state will be

A.  $3.2 \times 10^{-10} J$

B.  $3.2 \times 10^{-18} J$

C. 1 N

D. 1 dyne

**Answer: B**



[Watch Video Solution](#)

**63.** The work done in bringing a 20 coulomb charge from point  $A$  to point  $B$  for distance  $0.2m$  is  $2J$ . The potential difference between the two points will be (in volt)

A. 0.2

B. 8

C. 0.1

D. 0.4

**Answer: C**

 [Watch Video Solution](#)

64. If  $4 \times 10^{20} eV$  energy is required to move a charge of 0.25 coulomb between two points. Then what will be the potential difference between them ?

A. 178 V

B. 256 V

C. 356 V

D. None of these

**Answer: B**

 [Watch Video Solution](#)

65. Kinetic energy of an electron accelerated in a potential difference of  $100V$  is

A.  $1.6 \times 10^{-17} J$

B.  $1.6 \times 10^{21} J$

C.  $1.6 \times 10^{-29} J$

D.  $1.6 \times 10^{-34} J$

**Answer: A**



[Watch Video Solution](#)

66. A hollow conducting sphere is placed in an electric field produced by a point charge placed at  $P$  as shown in figure.

Let  $V_A, V_B, V_C$  be the potentials at points  $A, B$  and  $C$

respectively. Then

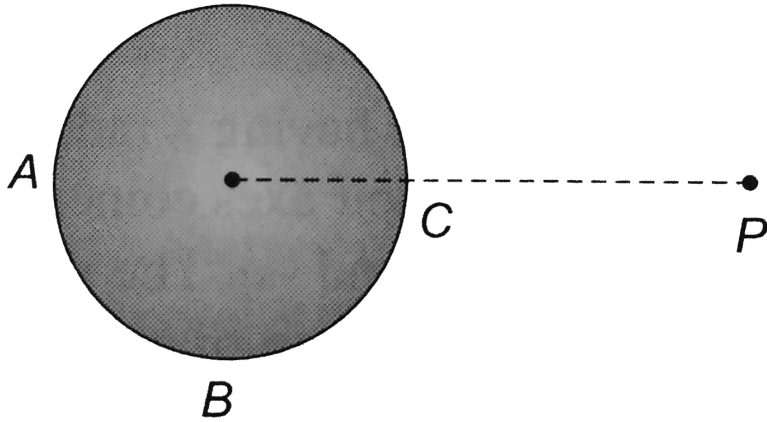

A.  $V_C > V_B$

B.  $V_B > V_C$

C.  $V_A > V_B$

D.  $V_A = V_C$

**Answer: D**



**Watch Video Solution**



67. Two unlike charges of magnitude  $q$  are separated by a distance  $2d$ . The potential at a point midway between them is

A. zero

B.  $\frac{1}{4\pi\epsilon_0}$

C.  $\frac{1}{4\pi\epsilon_0} \cdot \frac{q}{d}$

D.  $\frac{1}{4\pi\epsilon_0} \cdot \frac{2q}{d}$

**Answer: A**



**Watch Video Solution**

68. Two spheres  $A$  and  $B$  of radius ' $a$ ' and ' $b$ ' respectively are at same electric potential. The ratio of the surface charge densities of  $A$  and  $B$  is

A.  $\frac{a}{b}$

B.  $\frac{b}{a}$

C.  $\frac{a^2}{b^2}$

D.  $\frac{b^2}{a^2}$

**Answer: B**



**Watch Video Solution**

**69.** A capacitor of  $2\mu F$  charged to 50 V is connected in parallel with another capacitor of  $1\mu F$  charged to 20 V. The common potential and loss of energy will be

A.  $40V, 300\mu J$

B.  $50V, 400\mu J$

C.  $40V, 600\mu J$

D.  $50V, 700\mu J$

Answer: A

 Watch Video Solution

70. In the electric field of a point charge  $q$ , a certain charge is carried from point  $A$  to  $B$ ,  $C$ ,  $D$  and  $E$ . Then the work done

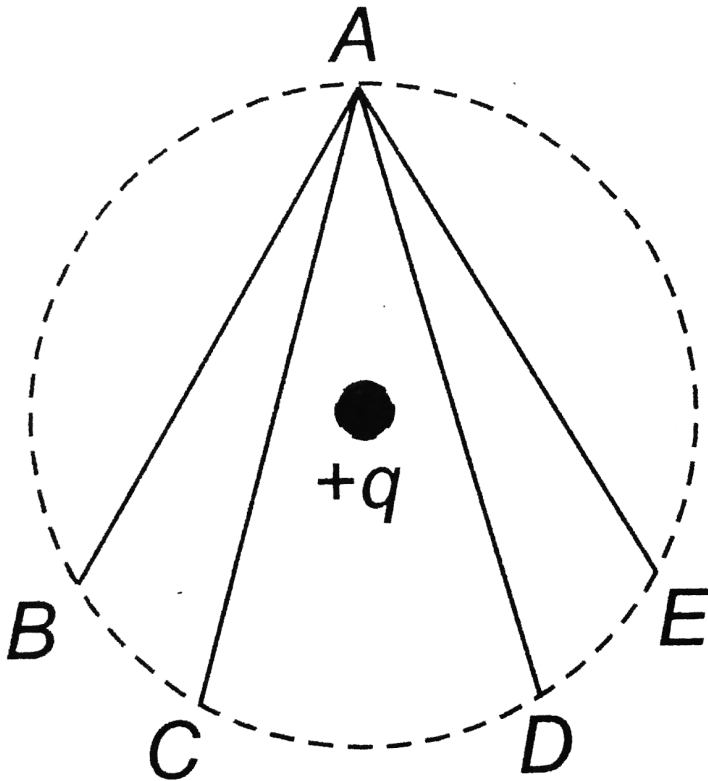

A. is least along the path AB

B. is least along the path AD

C. is zero along all the path AB,AC,AD and AE

D. is least along AE

**Answer: C**



[Watch Video Solution](#)

71. A uniform electric field having a magnitude  $E_0$  and direction along the positive X-axis exists. If the potential  $V$  is zero at  $x = 0$ , then its value at  $X = +x$  will be

A.  $+x E_0$

B.  $-x E_0$

C.  $+x^2 E_0$

D.  $-x^2 E_0$

**Answer: B**

 [Watch Video Solution](#)

72. Two positive point charges of 12 and 5 microcoulombs, are placed 10 cm apart in air. The work needed to bring them 4 cm closer is

A. 3.6 J

B. 2.6 J

C. 4.8 J

D. 6.0 J

**Answer: A**

 [Watch Video Solution](#)

73. When a charge of 3 coulombs is placed in a uniform electric field, it experiences a force of 3000 newton. Within this field, potential difference between two points separated by a distance of 1cm is

- A. 10 V
- B. 100 V
- C. 30 V
- D. 300 V

**Answer: A**

 [Watch Video Solution](#)

74. A particle  $A$  has charge  $+q$  and a particle  $B$  has charge  $+4q$  with each of them having the same mass  $m$ . When allowed to fall

from rest through the same electric potential difference, the ratio of their speed  $\frac{v_A}{v_B}$  will become

A. 2:1

B. 1:2

C. 1:4

D. 4:1

**Answer: B**

 [Watch Video Solution](#)

**75.** Three particles, each having a charge of  $10\mu C$  are placed at the corners of an equilateral triangle of side  $10cm$ . The electrostatic potential energy of the system is (Given

$$\frac{1}{4\pi\epsilon_0} = 9 \times 10^9 N - m^2 / C^2)$$

- A. zero
- B. infinite
- C. 27 J
- D. 100 J

**Answer: C**



[Watch Video Solution](#)

**76.** A mass  $m = 20g$  has a charge  $q = 3.0mC$ . It moves with a velocity of 20 m/s and enters a region of electric field of 80 N/C in the same direction as the velocity of the mass. The velocity of the mass after 3 s in this region is

- A. 80 m/s
- B. 56 m/s
- C. 44 m/s



D. 40 m/s

**Answer: B**

 [Watch Video Solution](#)

77. Four identical charges  $+50\mu\text{C}$  each are placed, one at each corner of a square of side  $2\text{m}$ . How much external energy is required to bring another charge of  $+50\mu\text{C}$  from infinity to the centre of the square

(Given  $\frac{1}{4\pi\epsilon_0} = 9 \times 10^9 \frac{\text{Nm}^2}{\text{C}^2}$ )

A. 64 J

B. 41 J

C. 16 J

D. 10 J

**Answer: A**



**Watch Video Solution**

**78.** Two equal charges  $q$  are placed at a distance of  $2a$  and a third charge  $-2a$  is placed at the midpoint. The potential energy of the system is

A.  $\frac{q^2}{8\pi\epsilon_0 a}$

B.  $\frac{6q^2}{8\pi\epsilon_0 a}$

C.  $-\frac{7q^2}{8\pi\epsilon_0 a}$

D.  $-\frac{9q^2}{8\pi\epsilon_0 a}$

**Answer: C**



**Watch Video Solution**

79. An  $\alpha$ -particle is accelerated through a.p.d of  $10^6$  volt the  $K. E.$

of particle will be

A. 1 MeV

B. 2 MeV

C. 4 MeV

D. 8 MeV

**Answer: B**



[Watch Video Solution](#)

80. The ratio of moment of an electron and an  $\alpha$ -particle which are accelerated from rest by a potential difference of  $100V$  is

A. 1

B.  $\sqrt{\frac{2m_e}{m_\alpha}}$

C.  $\sqrt{\frac{m_e}{m_\alpha}}$

D.  $\sqrt{\frac{m_e}{2m_\alpha}}$

**Answer: D**



**Watch Video Solution**

**81.** Two particles of mass  $m$  and  $2m$  with charges  $2q$  and  $q$  are placed in a uniform electric field  $E$  and allowed to move for same time. Find the ratio of their kinetic energie

A. 8:1

B. 4:1

C. 2:1

D. 16:1

**Answer: D**

 [Watch Video Solution](#)

82. A spherical condenser has inner and outer spheres of radii  $a$  and  $b$  respectively. The space between the two is filled with air. The difference between the capacities of two condensers formed when outer sphere is earthed and when inner sphere is earthed will be

A. zero

B.  $4\pi\epsilon_0 a$

C.  $4\pi\epsilon_0 b$

D.  $4\pi\epsilon_0 a \left( \frac{b}{b-a} \right)$

**Answer: C**

 [View Text Solution](#)

83. Three charges are placed at the vertices of an equilateral triangle of side 10 cm. Assume  $q_1 = 1\mu C$ ,  $q_2 = -2\mu C$  and  $q_3 = 4\mu C$ . Work done in separating the charges to infinity is

- A.  $-4.5J$
- B.  $4.5J$
- C. 45 J
- D. None of these

**Answer: D**

 [Watch Video Solution](#)

84. A particle of mass 2 g and charge  $1\mu C$  is held at rest on a frictionless surface at a distance of 1m from a fixed charge of 1 mC.

If the particle is released it will be repelled. The speed of the particle when it is at distance of 10 m from fixed charge is :

A.  $10\text{ms}^{-1}$

B.  $20\text{ms}^{-1}$

C.  $60\text{ms}^{-1}$

D.  $90\text{ms}^{-1}$

**Answer: D**



[Watch Video Solution](#)

**85.** A point charge is surrounded symmetrically by six identical charges at distance  $r$  as shown in the figure How much work is done by the forces of electrostatic repulsion when the point charge

at the centre is removed to infinity?

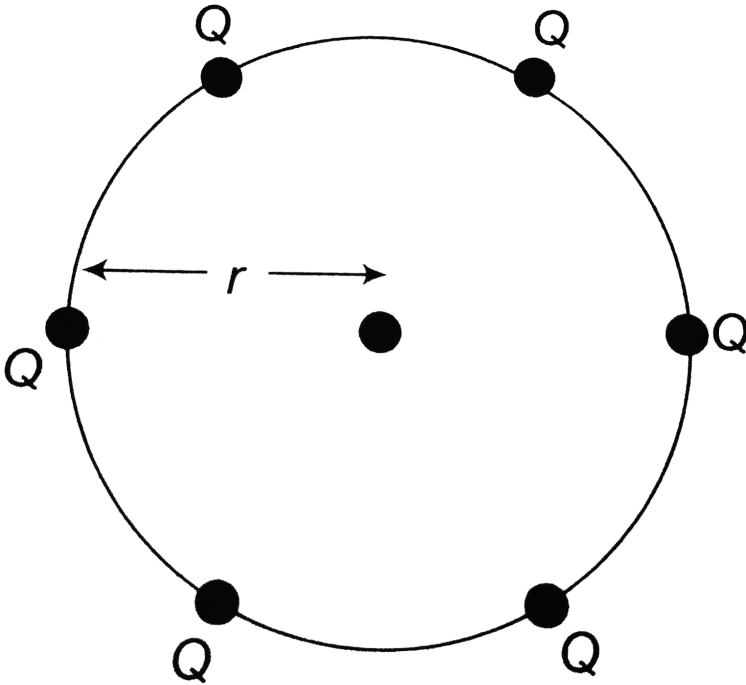

A.  $6q / 4\pi\epsilon_0 r$

B.  $6q^2 / 4\pi\epsilon_0 r$

C.  $36q^2 / 4\pi\epsilon_0 r$

D. zero

**Answer: B**

 [Watch Video Solution](#)



86. Five capacitors of  $10\mu F$  capacity each are connected to a d. c potential of 100 volts as shown in the adjoining figure. The equivalent capacitance between the points  $A$  and  $B$  will be equal to

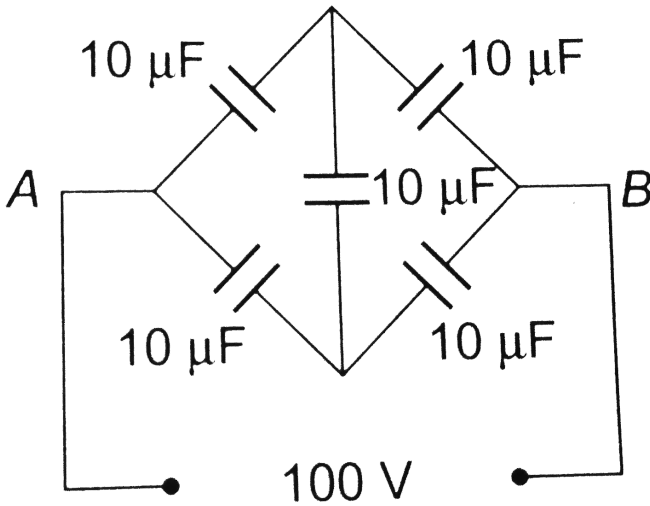

- A.  $40\mu F$
- B.  $20\mu F$
- C.  $30\mu F$
- D.  $10\mu F$

**Answer: D**

 [Watch Video Solution](#)

87. Three capacitors of capacitances  $3\mu F$ ,  $9\mu F$  and  $18\mu F$  are connected one in series and another time in parallel. The ratio of equivalent capacitance in the two cases  $\left(\frac{C_s}{C_p}\right)$  will be

A. 1 : 15

B. 15 : 1

C. 1 : 1

D. 1 : 3

**Answer: A**

 [Watch Video Solution](#)

88. In the circuit diagram shown in the adjoining figure, the resultant capacitance between  $P$  and  $Q$  is

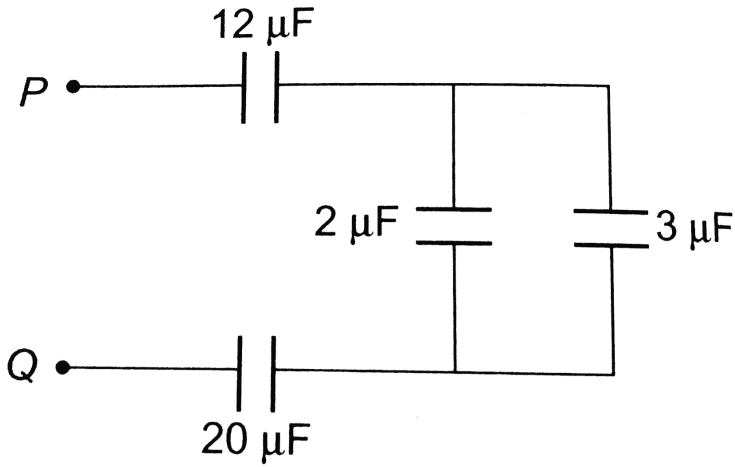

- A.  $47\ \mu\text{F}$
- B.  $3\ \mu\text{F}$
- C.  $60\ \mu\text{F}$
- D.  $10\ \mu\text{F}$

**Answer: B**

 [Watch Video Solution](#)

89. Four capacitors of each of capacity  $3\mu F$  are connected as shown in the adjoining figure. The ratio of equivalent capacitance between  $A$  and  $B$  and between  $A$  and  $C$  will be

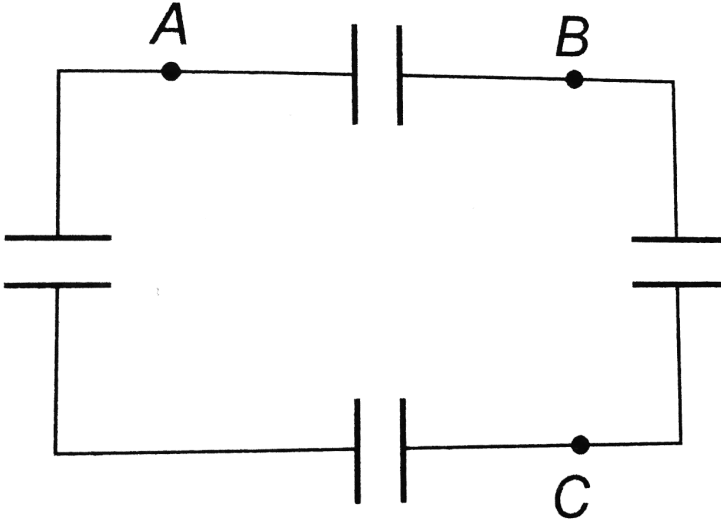

- A. 4 : 3
- B. 3 : 4
- C. 2 : 3
- D. 3 : 2

**Answer: A**

90. What is the equivalent capacitance between A and B in the given figure (all are in farad) ?



A.  $\frac{13}{18} F$

B.  $\frac{48}{13} F$

C.  $\frac{1}{31} F$

D.  $\frac{240}{71} F$

**Answer: D**

[View Text Solution](#)

91. Four capacitors are connected as shown . The equivalent capacitance between the points P and Q is



A.  $4\mu F$

B.  $\frac{1}{4}\mu F$

C.  $\frac{3}{4}\mu F$

D.  $\frac{4}{3}\mu F$

**Answer: D**



**View Text Solution**

**92.** The total capacity of the system of capacitors shown in the adjoining figure between the points  $A$  and  $B$  is

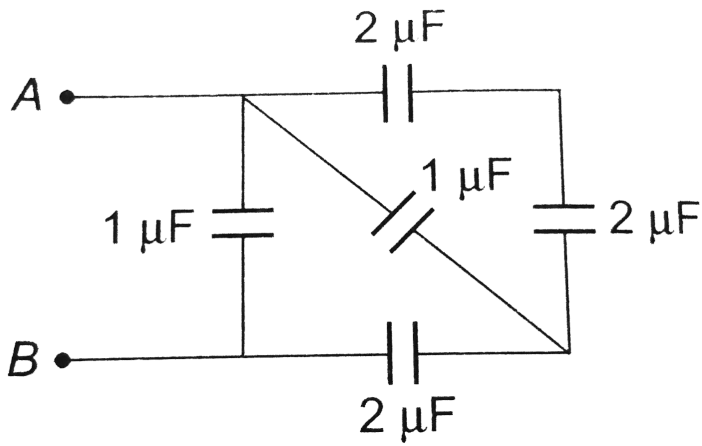

A.  $1\ \mu\text{F}$

B.  $2\ \mu\text{F}$

C.  $3\ \mu\text{F}$

D.  $4\ \mu\text{F}$

**Answer: B**



**Watch Video Solution**

93. Four capacitors are connected in a circuit as shown in the figure. The effective capacitance in  $\mu F$  between points  $A$  and  $B$  will be

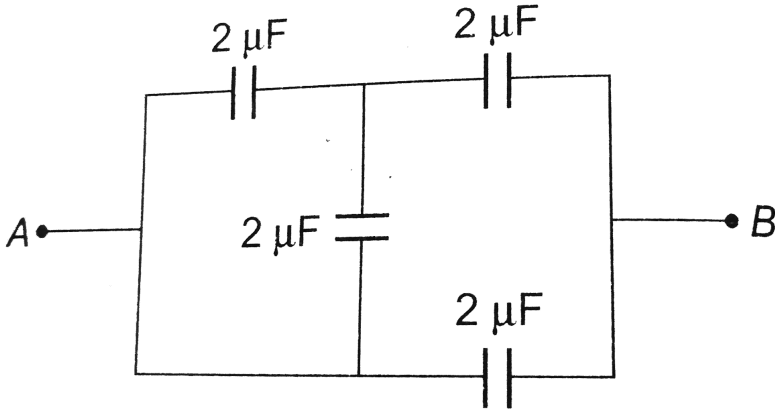

A.  $\frac{28}{9}$

B. 4

C. 5

D. 18

Answer: C



Watch Video Solution



94. In the given network capacitance,  $C_1 = 10\mu F$ ,  $C_2 = 5\mu F$  and  $C_3 = 4\mu F$ . What is the resultant capacitance between  $A$  and  $B$ ?

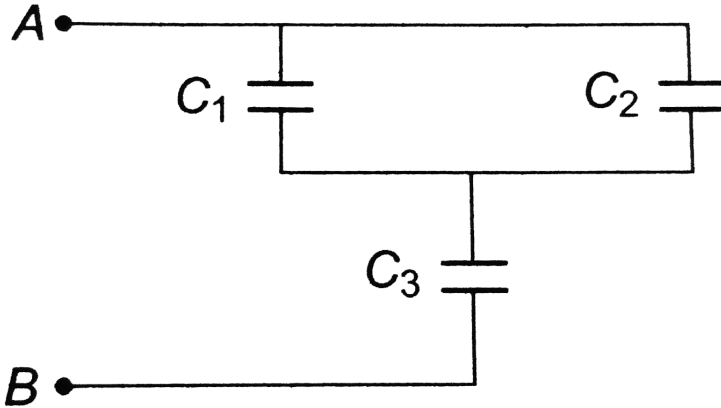

- A.  $2.2\mu F$
- B.  $3.2\mu F$
- C.  $1.2\mu F$
- D.  $4.7\mu F$

Answer: B



Watch Video Solution

95. The equivalent capacitance between points A and B is



A.  $2\mu F$

B.  $3\mu F$

C.  $5\mu F$

D.  $0.5\mu F$

**Answer: D**



**View Text Solution**

96. The capacitance between the points  $A$  and  $B$  in the given circuit will be

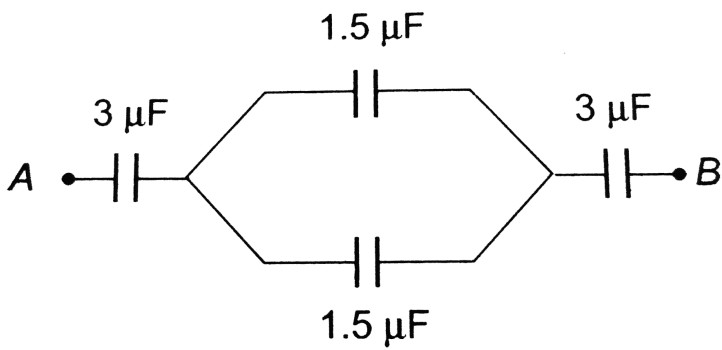

- A.  $1\ \mu\text{F}$
- B.  $2\ \mu\text{F}$
- C.  $3\ \mu\text{F}$
- D.  $4\ \mu\text{F}$

**Answer: A**

[▶ Watch Video Solution](#)

97. Four equal capacitors, each of capacity  $C$ , are arranged as shown. The effective capacitance between  $A$  and  $B$  is

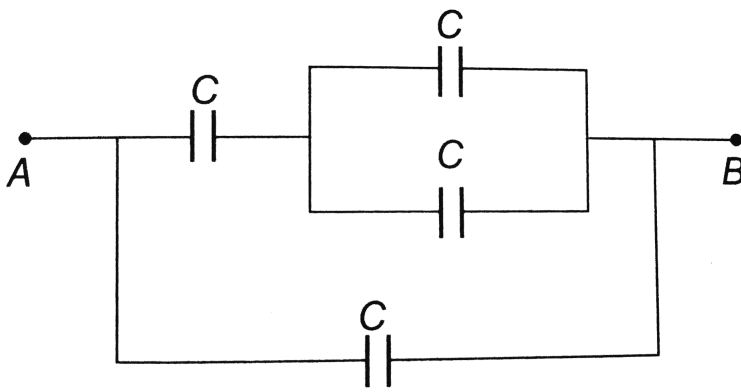

- A.  $\frac{5}{8}C$
- B.  $\frac{3}{5}C$
- C.  $\frac{5}{3}C$
- D.  $C$

**Answer: C**

 [Watch Video Solution](#)

**98.** There are 7 identical capacitors. The equivalent capacitance when they are connected in series is  $C$ . The equivalent capacitance

when they are connected in parallel is

A.  $C/49$

B.  $C/7$

C.  $7C$

D.  $49C$

**Answer: D**



[Watch Video Solution](#)

**99.** The capacitance of a parallel plate capacitor is  $16\mu F$ . When a glass slab is placed between the plates, the potential difference reduces to  $1/8$ th of the original value. What is dielectric constant of glass ?

A. 4

B. 8

C. 16

D. 32

**Answer: B**



**Watch Video Solution**

**100.** A parallel plate condenser with air between the plates possesses the capacity of  $10^{-12} F$ . Now, the plates are removed apart, so that the separation is twice the original value. The space between the plates is filled with a material of dielectric constant 4.0. Then new value of the capacity is (in farad)

A.  $4 \times 10^{-12}$

B.  $3 \times 10^{-12}$

C.  $2 \times 10^{-12}$

D.  $0.5 \times 10^{-12}$

**Answer: C**

 [Watch Video Solution](#)

**101.** Three condensers each of capacity  $C$  microfarad are connected in series. An exactly similar set is connected in parallel to the first one. The effective capacity of the combination is  $4\mu F$ . Then, the value of  $C$  in microfarad is

A. 8

B. 6

C. 4

D. 2

**Answer: B**

102. Three plates of common surface area  $A$  are connected as shown. The effective capacitance will be

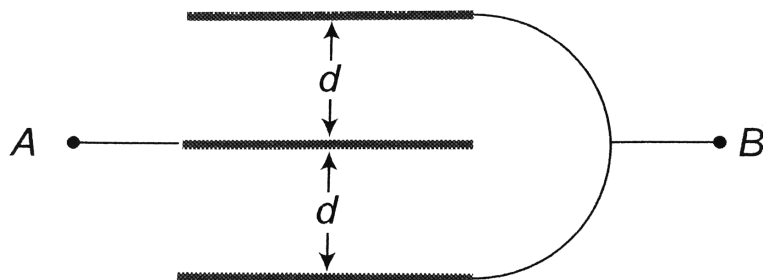

- A.  $\frac{\epsilon_0 A}{d}$
- B.  $\frac{3\epsilon_0 A}{d}$
- C.  $\frac{3}{2} \frac{\epsilon_0 A}{d}$
- D.  $\frac{2\epsilon_0 A}{d}$

Answer: D



**103.** Eight drops of mercury of equal radii possessing equal charges combine to form a big drop. Then the capacitance of bigger drop compared to each individual small drop is

A. 2 times

B. 8 times

C. 4 times

D. 16 times

**Answer: A**

 [Watch Video Solution](#)

**104.** Consider a disconnected. Plate capacitor of capacity  $10\mu F$  with air filled in the gap between the plates. Now one-half of the space between the plates is filled with a dielectric of dielectric constant 4

as shown in .The capacity of the capacitor changes to

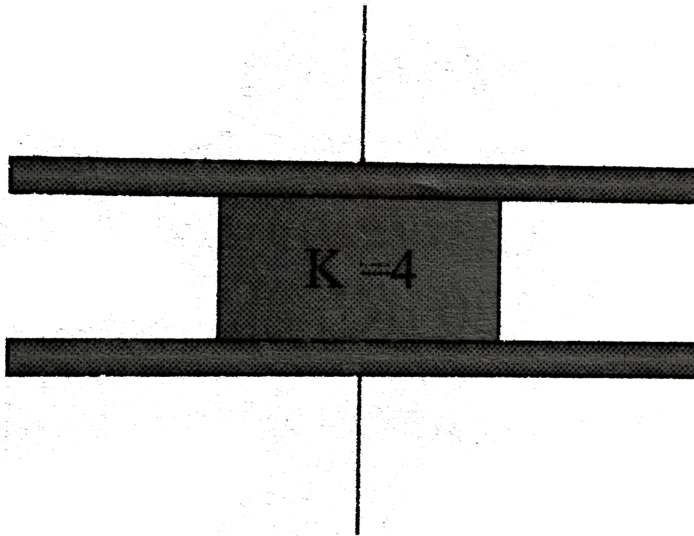

- A.  $25\mu F$
- B.  $20\mu F$
- C.  $40\mu F$
- D.  $5\mu F$

**Answer: A**

 [Watch Video Solution](#)

105. A capacitor of capacity  $C$  is connected with a battery of potential  $V$  in parallel. The distance between its plates is reduced to half at one, assuming that the charge remains the same. Then to charge the capacitance upto the potential  $V$  again, the energy given by the battery will be

A.  $CV^2/4$

B.  $CV^2/2$

C.  $2CV^2/4$

D.  $CV^2$

**Answer: D**



**Watch Video Solution**

106. A parallel plate capacitor has plate separation  $d$  and capacitance  $25\mu F$ . If a metallic foil of thickness  $\frac{2}{7}d$  is introduced

between the plates, the capacitance would become

A.  $25\mu F$

B.  $35\mu F$

C.  $\frac{125}{7}\mu F$

D.  $\frac{175}{2}\mu F$

**Answer: B::C**



[Watch Video Solution](#)

**107.** The capacity and the energy stored in a parallel plate condenser with air between its plates are respectively  $C_0$  and  $W_0$ . If the air is replaced by glass (dielectric constant = 5) between the plates, the capacity of the plates and the energy stored in it will respectively be

A.  $5C_0, 5W_0$

B.  $5C_0, \frac{W_0}{5}$

C.  $\frac{C_0}{5}, 5W_0$

D.  $\frac{C_0}{5}, \frac{W_0}{5}$

**Answer: C**



**Watch Video Solution**

**108.** A slab of copper of thickness  $b$  is inserted in between the plates of parallel plate capacitor as shown in figure. The separation of the plate is  $d$ . If  $b = d/2$ , then the ratio of capacities of the capacitor after and before inserting that slab will be



A.  $\sqrt{2}:1$

B.  $2:1$

C.  $1:1$

D.  $1: \sqrt{2}$

**Answer: D**



[View Text Solution](#)

**109.** A capacitor when filled with a dielectric  $K = 3$  has charge  $Q_0$ , voltage  $V_0$  and field  $E_0$ . If the dielectric is replaced with another one having  $K = 9$  the new values of charge, voltage and field will be respectively

A.  $3Q_0, 3V_0, 3E_0$

B.  $Q_0, 3V_0, 3E_0$

C.  $Q_0, \frac{V_0}{3}, 3E_0$

D.  $Q_0, \frac{V_0}{3}, \frac{E_0}{3}$

**Answer: D**

110. In the adjoining figure, four capacitors are shown with their respective capacities and the *P. D.* applied. The charge and the *P. D.* Across the  $4\mu F$  capacitor will be

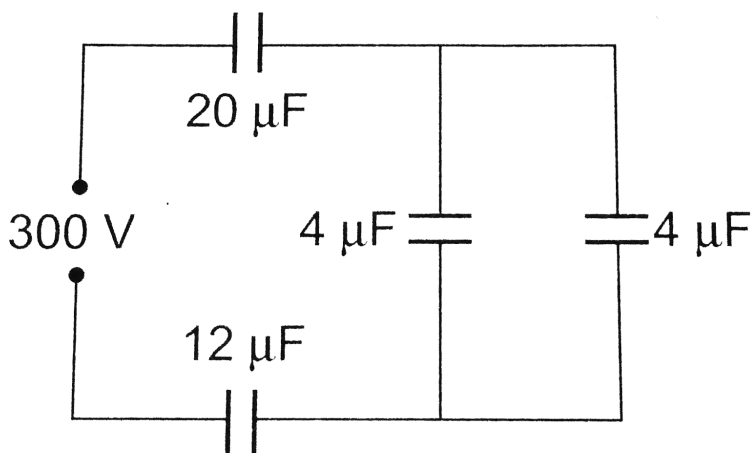

- A.  $600\mu C, 150V$
- B.  $300\mu C, 75V$
- C.  $800\mu C, 200V$
- D.  $580\mu C, 145V$

Answer: D

 Watch Video Solution

111. Two condensers  $C_1$  and  $C_2$  in a circuit are joined as shown in fig. The potential of point  $A$  is  $V_1$  and that of  $B$  is  $V_2$ . The potential of point  $D$  will be `

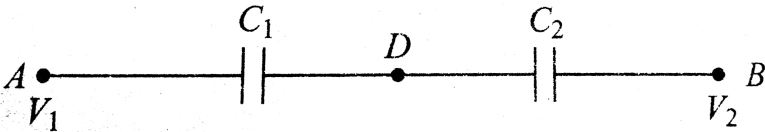

- A.  $\frac{1}{2}(V_1 + V_2)$
- B.  $\frac{C_2 V_1 + C_1 V_2}{C_1 + C_2}$
- C.  $\frac{C_1 V_1 + C_2 V_2}{C_1 + C_2}$
- D.  $\frac{C_2 V_1 - C_1 V_2}{C_1 + C_2}$

Answer: C

 Watch Video Solution



112. Three capacitors of  $2\mu F$ ,  $3\mu F$  and  $6\mu F$  are joined in series and the combination is charged by means of a 24 volt battery. The potential difference between the plates of the  $6\mu F$  capacitor is

- A. 4 V
- B. 6 V
- C. 8 V
- D. 10 V

**Answer: A**

[Watch Video Solution](#)

113. In the figure a potential of  $+1200V$  is given to point  $A$  and point  $B$  is earthed, what is the potential at the point  $P$  ?

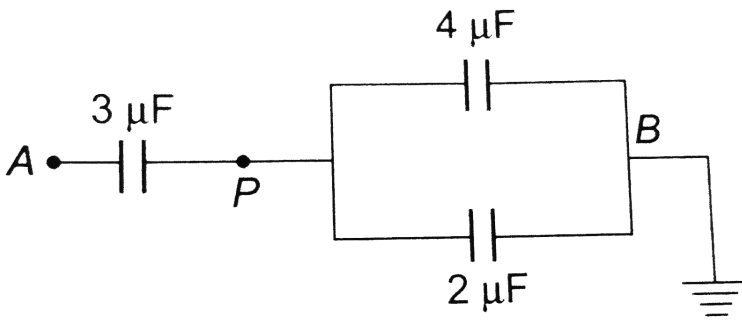

- A. 100 V
- B. 200 V
- C. 400 V
- D. 800 V

Answer: C



Watch Video Solution

114. The charge on  $4\ \mu\text{F}$  capacitor in the given circuit is (in  $\mu\text{C}$ )



A. 12

B. 24

C. 36

D. 32

**Answer: B**



[View Text Solution](#)

**115.** Four identical capacitors are connected as shown in diagram.

When a battery of  $6V$  is connected between  $A$  and  $B$ , the charges

stored is found to be  $1.5\mu C$ . The value of  $C_1$  is

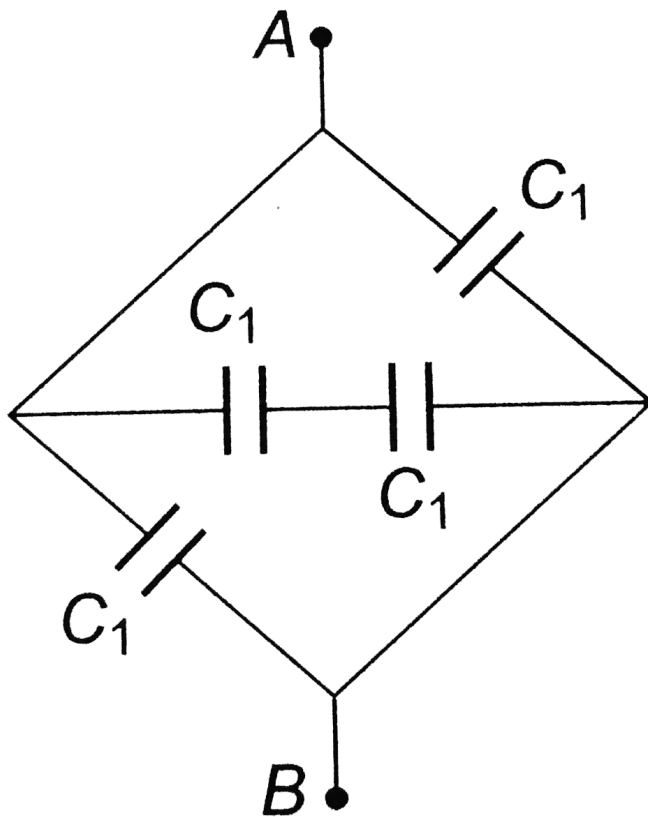

A.  $2.5\mu F$

B.  $15\mu F$

C.  $1.5\mu F$

D.  $0.1\mu F$

**Answer: D**

 [Watch Video Solution](#)

**116.** A dielectric slab of thickness  $d$  is inserted in a parallel plate capacitor whose negative plate is at  $x = 0$  and positive plate is at  $x = 3d$ . The slab is equidistant from the plates. The capacitor is given some charge. As one goes from 0 to  $3d$  (1998).

- A. the magnitude of the electric field remains the same
- B. the direction of the electric remains the same
- C. the electric potential increases continuously
- D. the electric potential increases at first, then decreases and again increases

**Answer: B::C**

 [Watch Video Solution](#)

117. A  $2\mu F$  condenser is charged upto 200 V and then battery is removed. On combining this with another uncharged condenser in parallel, the potential differences between two plates are found to be 40 V. The capacity of second condenser is

- A.  $2\mu F$
- B.  $4\mu F$
- C.  $8\mu F$
- D.  $16\mu F$

**Answer: C**

[Watch Video Solution](#)

**118.** Consider two conductors. One of them has a capacity of 2 units and the capacity of the other is unknown. They are charged until their potential are 4 and 5 units respectively. The two conductors are now connected by a wire when their common potential is found to be 4.6 units. Then the unknown capacity has the value (in the same units as above)

A. 6

B. 5

C. 4

D. 3

**Answer: D**



**Watch Video Solution**

119. Two capacitors  $2\mu F$  and  $4\mu F$  are connected in parallel. A third capacitor of  $6\mu F$  capacity is connected in series. The combination is connected across a 12 V battery. The voltage across a  $2\mu F$  capacitor is



- A. 2 V
- B. 6 V
- C. 8 V
- D. 1 V

**Answer: B**



[View Text Solution](#)



120. In the given circuit, if point  $b$  is connected to earth and a potential of  $1200V$  is given to point  $a$ , the charge on  $4\mu F$  capacitor is



- A.  $800\mu C$
- B.  $1600\mu C$
- C.  $2400\mu C$
- D.  $3000\mu C$

**Answer: B**

 [View Text Solution](#)

121. A circuit is shown in the figure below. Find out the charge of the condenser having capacity  $5\mu F$

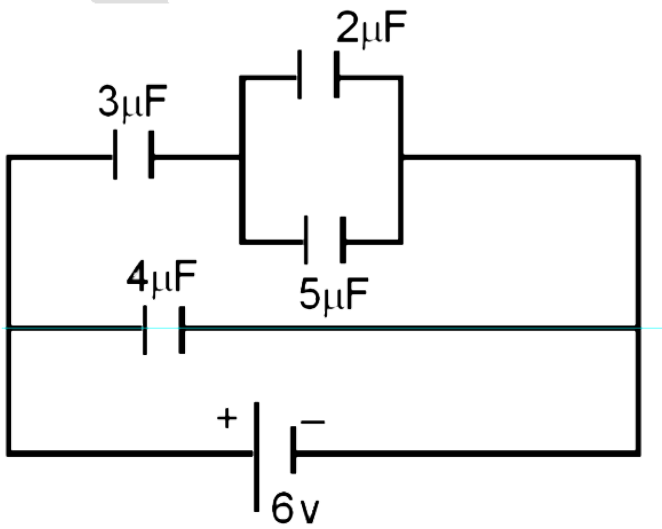

- A.  $4.5\mu C$
- B.  $9\mu C$
- C.  $7\mu C$
- D.  $30\mu C$

**Answer: B**

[Watch Video Solution](#)

122. A potential of  $V = 3000V$  is applied to a combination of four initially uncharged capacitors as shown in the figure. Capacitors A, B, C and D have capacitances  $C_A = 6.0\mu F$ ,  $C_B = 5.2\mu F$ ,  $C_C = 1.5\mu F$  and  $C_D = 3.8\mu F$ , respectively. If the battery is disconnected, then potential difference across capacitor B is (approximately)



- A. 3000 V
- B. zero
- C. 530 V
- D. 350 V

**Answer: D**



**View Text Solution**

123. Four capacitors are arranged as shown. All are initially uncharged. A 30 V battery is palced across terminal  $PQ$  to charge the capacitors and is then removed. The voltage across the terminals RS is then (in volt)



A. 10

B. 20

C. 30

D. 40

**Answer: A**



[View Text Solution](#)

124. If the equivalent capacitance between points P and Q of the combination of the capacitors show in figure below is  $30\mu F$ , the

capacitor C is



A.  $60\mu F$

B.  $30\mu F$

C.  $10\mu F$

D.  $5\mu F$

**Answer: A**

 [View Text Solution](#)

**125.** In the circuit shown in,  $C = 6\mu F$ . The charge stored in the capacitor of capacity C is`

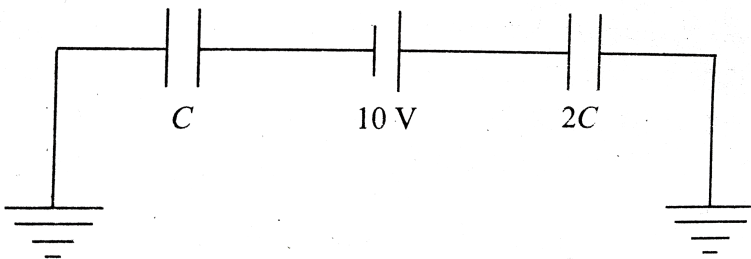

A. zero

B.  $90\mu C$

C.  $40\mu C$

D.  $60\mu C$

**Answer: D**



[Watch Video Solution](#)

**126.** In the circuit shown in figure. Charge stored in  $6\mu F$  capacitor will be



A.  $18\mu C$

B.  $54\mu C$

C.  $36\mu C$

D.  $72\mu C$

**Answer: A**



[View Text Solution](#)

**127.** In the given circuit, if point C is connected to the earth and a potential of  $+2000V$  is given to the point A, the potential at B is



A. 1500 V

B. 1000 V

C. 500 V

D. 400 V

**Answer: C**



[View Text Solution](#)

128. In the given network capacitance,  $C_1 = 10\mu F$ ,  $C_2 = 5\mu F$  and  $C_3 = 4\mu F$ . What is the resultant capacitance between  $A$  and  $B$ ?

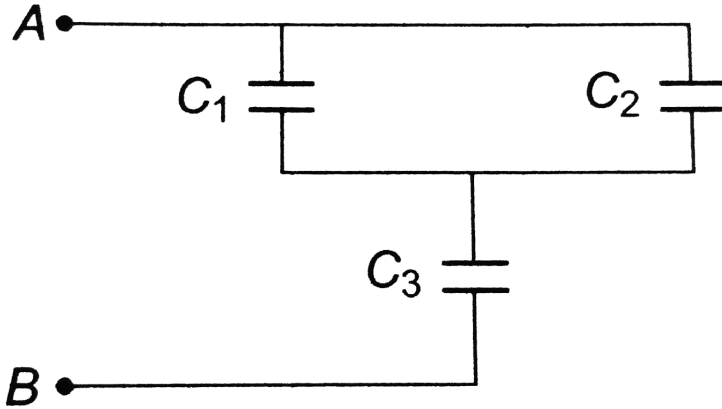

- A.  $2.2\mu F$
- B.  $3.2\mu F$
- C.  $1.2\mu F$
- D.  $4.7\mu F$

**Answer: B**

 [Watch Video Solution](#)



129. Two condensers, one of capacity  $C$  and the other of capacity  $C/2$  are connected to a  $V$  volt battery, as shown.

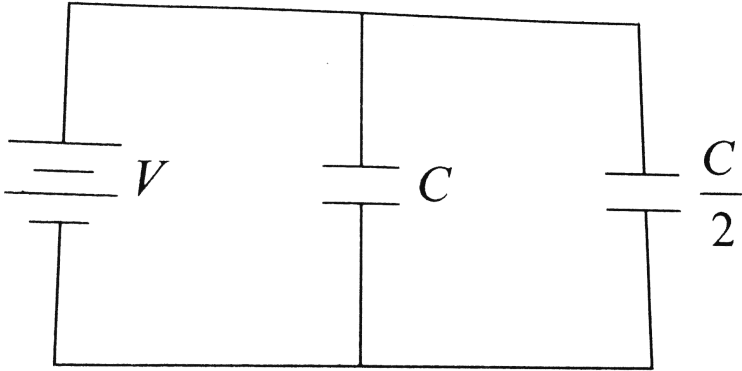

The work done in charging fully both the condensers is

- A.  $2CV^2$
- B.  $1/4CV^2$
- C.  $3/4CV^2$
- D.  $\frac{1}{2}CV^2$

**Answer: C**



130. In the circuit shown here  $C_1 = 6\mu F$ ,  $C_2 = 3\mu F$  and battery  $B = 20V$ . The Switch  $S_1$  is first closed. It is then opened and afterwards  $S_2$  is closed. What is the charge finally on  $C_2$

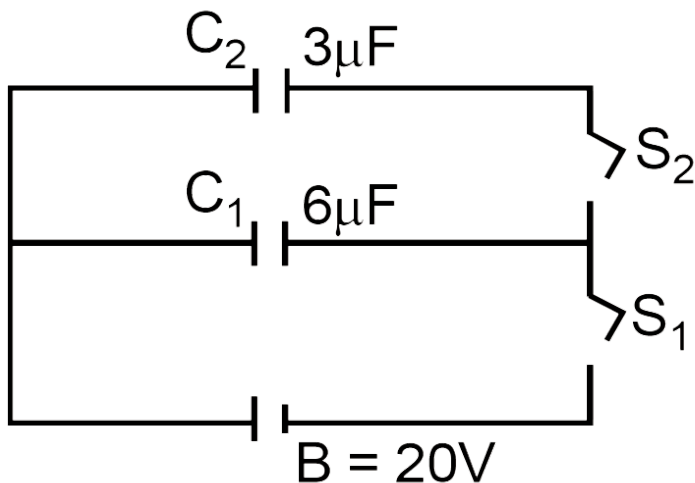

- A.  $120\mu C$
- B.  $80\mu C$
- C.  $40\mu C$
- D.  $20\mu C$

Answer: C

 Watch Video Solution

131. Consider the arrangement of three plates  $X$ ,  $Y$  and  $Z$  each of the area  $A$  and separation is  $d$ . The energy stored when the plates are fully charged is

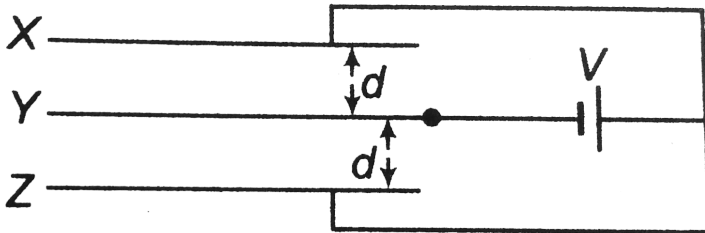

- A.  $\frac{\epsilon_0 AV^2}{2d}$
- B.  $\frac{\epsilon_0 AV^2}{d}$
- C.  $\frac{2\epsilon_0 AV^2}{d}$
- D.  $\frac{3\epsilon_0 AV^2}{2d}$

**Answer: B**

 [Watch Video Solution](#)

**132.** A light bulb, a capacitor and a battery are connected together as shown here, with switch  $S$  initially open. When the switch  $S$  is closed, then which one of the following is true



- A. the bulb will light up for an instant when the capacitor starts charging
- B. the bulb will light up when the capacitor is fully charged
- C. the bulb will not light up at all
- D. the bulb will light up and go off at regular intervals

**Answer: A**



[View Text Solution](#)

**133.** Point charges  $+4q$ ,  $-q$  and  $+4q$  are kept on the x-axis at points  $x = 0$ ,  $x = a$  and  $x = 2a$  respectively, then

- A. Only  $-q$  is in stable equilibrium
- B. None of the charges are in equilibrium
- C. All the charges are in unstable equilibrium
- D. All the charges are in stable equilibrium

**Answer: C**

 [Watch Video Solution](#)

**134.** Two spherical conductors of radii  $4\text{cm}$  and  $5\text{cm}$  are charged to the same potential. If  $\sigma_1$  and  $\sigma_2$  be respective value of surface

density of charge on both the conductors, then the ratio of  $\sigma_1/\sigma_2$

will be

A.  $\frac{16}{25}$

B.  $\frac{15}{10}$

C.  $\frac{4}{5}$

D.  $\frac{5}{4}$

**Answer: D**



**Watch Video Solution**

**135.** A hollow charged metal sphere has radius  $r$ . If the potential difference between its surface and a point at a distance  $3r$  from the centre is  $V$ , then electric field intensity at a distance  $3r$  is

A.  $\frac{V}{2r}$

B.  $\frac{V}{3r}$

C.  $\frac{V}{6r}$

D.  $\frac{V}{4r}$

**Answer: C**



**Watch Video Solution**

**136.** Charge  $Q$  on a capacitor varies with voltage  $V$  as shown in the figure, where  $Q$  is taken along the X-axis and  $V$  along the Y-axis. The area of triangle OAB represents



- A. capacitance
- B. capacitive reactance
- C. electric field between the plates
- D. energy stored in the capacitor

**Answer: D**



**View Text Solution**

**137.** How many  $1\mu F$  capacitors must be connected in parallel to store a charge of 1 C with a potential of 110 V across the capacitors?

- A. 990
- B. 900
- C. 9090
- D. 909

**Answer: C**



**Watch Video Solution**



138. In the figure below, the capacitance of each capacitor is  $3\mu F$ .

The effective capacitance between points A and B is



A.  $\frac{3}{4}\mu F$

B.  $3\mu F$

C.  $6\mu F$

D.  $5\mu F$

**Answer: D**



[View Text Solution](#)

139. The  $500\mu F$  capacitor is charged at a steady rate of  $100\mu C / s$ .

The potential difference across the capacitor will be 10 V after an interval of

A. 5 s

B. 10 s

C. 50 s

D. 100 s

**Answer: C**



**Watch Video Solution**

**140.** A ball of mass  $1g$  and charge  $10^{-8}C$  moves from a point  $A$ . Where potential is  $600$  volt to the point  $B$  where potential is zero. Velocity of the ball at the point  $B$  is  $20cm/s$ . The velocity of the ball at the point  $A$  will be

A.  $22.8 \text{ cms}^{-1}$

B.  $228 \text{ cms}^{-1}$

C.  $16.8 \text{ ms}^{-1}$

D.  $168 \text{ ms}^{-1}$

Answer: A

 Watch Video Solution

141. In the circuit shown in the figure, the potential difference across the  $4.5 \mu\text{F}$  capacitor is

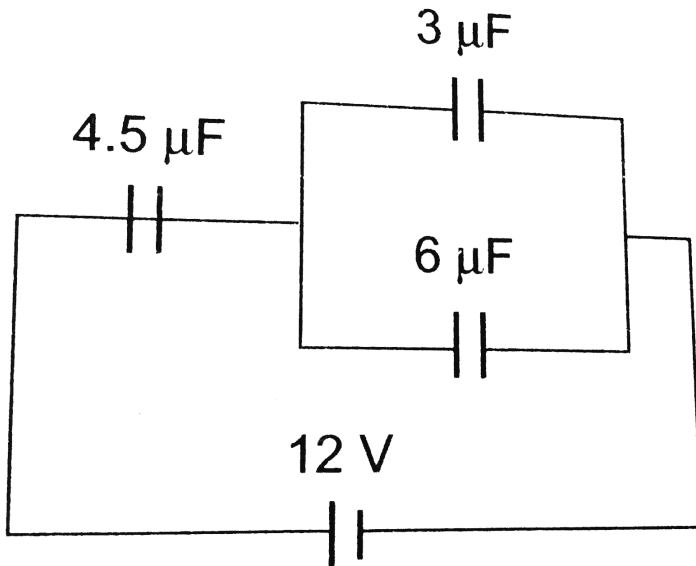

A.  $\frac{8}{3} \text{ V}$

B. 4 V

C. 6 V

D. 8 V

**Answer: D**



**Watch Video Solution**

**142.** Three capacitors of capacitances  $1\mu F$ ,  $2\mu F$  and  $4\mu F$  are connected first in a series combination, and then in parallel combination. The ratio of their equivalent capacitances will be

A. 2: 49

B. 49: 2

C. 4: 49

D. 49: 4

**Answer: C**



**Watch Video Solution**

**143.** An electron moving with the speed  $5 \times 10^6$  per sec is shot parallel to the electric field of intensity  $1 \times 10^3 N/C$ . Field is responsible for the retardation of motion of electron. Now evaluate the distance travelled by the electron before coming to rest for an instant (mass of  $e = 9 \times 10^{-31} Kg$  charge  $= 1.6 \times 10^{-19} C$ )

A. 7 m

B. 0.7 mm

C. 7 cm

D. 0.7 cm

**Answer: C**



**Watch Video Solution**

144. The electric potential at a point  $(x, y, z)$  is given by

$$V = -x^2y - xz^3 + 4$$

The electric field  $\vec{E}$  at that point is

A.  $E = \hat{i}(2xy + z^3) + \hat{j}x^2 + \hat{k}3xz^2$

B.  $E = \hat{i}2xy + \hat{i}(x^2 + y^2) + \hat{k}(3xz - y^2)$

C.  $E = \hat{i}z^3 + \hat{j}xyz + \hat{k}z^2$

D.  $E = \hat{i}(2xy - z^3) + \hat{j}xy^2 + \hat{k}3z^2x$

Answer: A



Watch Video Solution

145. Three charges  $-q$ ,  $+Q$  and  $-q$  are placed in a straight line as shown



If the total potential energy of the system is zero, then the ratio  $\frac{q}{Q}$  is

- A. 2
- B. 5.5
- C. 4
- D. 1.5

**Answer: C**



[View Text Solution](#)

**146.** The mutual electrostatic potential energy between two protons which are at a distance of  $9 \times 10^{-15} m$ , in  ${}_{.92}U^{235}$  nucleus is

- A.  $1.56 \times 10^{-14} J$

B.  $5.5 \times 10^{-14} J$

C.  $2.56 \times 10^{-14} J$

D.  $4.56 \times 10^{-14} J$

**Answer: C**



**Watch Video Solution**

**147.** Three capacitor of capacitance  $C(\mu F)$  are connected in parallel to which a capacitor of capacitance  $C$  is connected in series.

Effective capacitance is  $3.75$ . then capacity off each capacitor is

A.  $4\mu F$

B.  $5\mu F$

C.  $6\mu F$

D.  $8\mu F$



Answer: B

 Watch Video Solution

148. Figure shows some equipotential lines distributed in space. A charged object is moved from point  $A$  to point  $B$ .

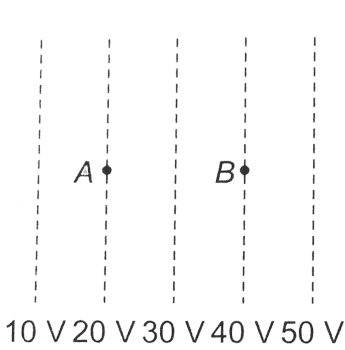

Fig. (i)

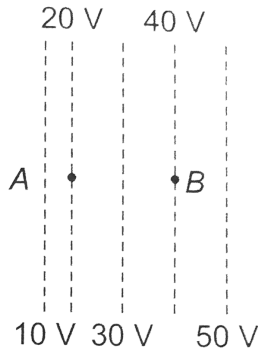

Fig. (ii)

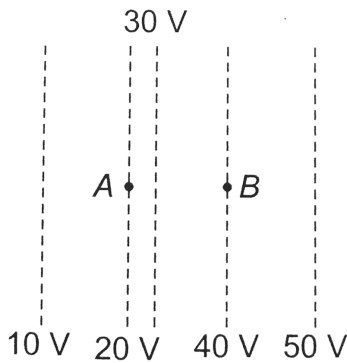

Fig. (iii)

- A. The work done in Fig. (i) is the greatest
- B. The work done in Fig. (ii) is least
- C. The work done is the same Fig. (i), Fig. (ii) and Fig. (iii)
- D. The work done in Fig, (iii) is greater than Fig. (ii) but equal to that in

**Answer: C**

 [Watch Video Solution](#)

**149.** The electrostatic potential on the surface of a charged conducting sphere is  $100V$ . Two statements are made in this regard

$S_1$  : at any inside the sphere, electric intensity is zero.

$S_2$  : at any point inside the sphere, the electrostatic potential is  $100V$ .

A.  $S_1$  is true but  $S_2$  is false

B. Both  $S_1$  and  $S_2$  are false

C.  $S_1$  is true  $S_2$  is also true and  $S_1$  is the cause of  $S_2$

D.  $S_1$  is true,  $S_2$  is also true but the statements are independent

**Answer: C**



**Watch Video Solution**

**150.** Two conducting spheres of radii 3 cm and 1 m are separated by a distance of 10 cm in free space. If the spheres are charged to same potential of 10 V each, then the force of repulsion between them is

A.  $\left(\frac{1}{3}\right) \times 10^{-9} N$

B.  $\left(\frac{2}{9}\right) \times 10^{-9} N$

C.  $\left(\frac{1}{9}\right) \times 10^{-9} N$

D.  $\left(\frac{4}{9}\right) \times 10^{-9} N$

**Answer: A**



**Watch Video Solution**

**151.** Three charges each  $+q$ , are placed at the corners of an isosceles triangle  $ABC$  of sides  $BC$  and  $AC$ ,  $2a$ ,  $D$  and  $E$  are the midpoints of  $BC$  and  $CA$ . The work done in taking a charge  $Q$  from  $D$

to  $E$  is

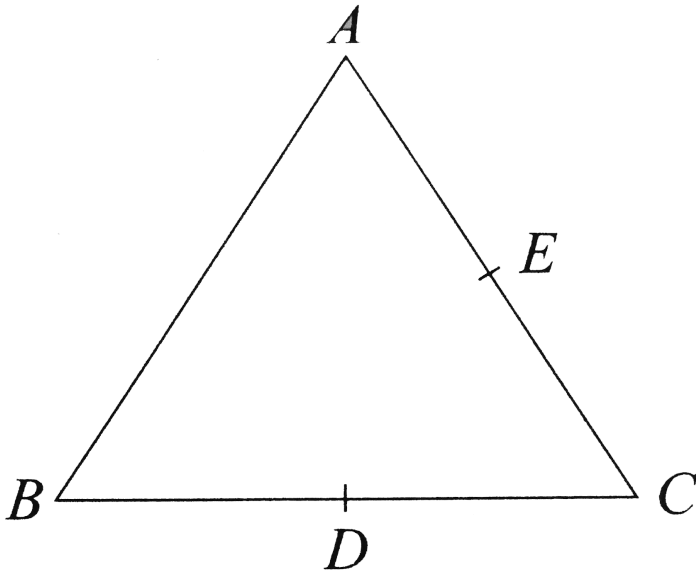

A. zero

B.  $\frac{3qQ}{4\pi\epsilon_0 a}$

C.  $\frac{3qQ}{8\pi\epsilon_0 a}$

D.  $\frac{qQ}{4\pi\epsilon_0 a}$

**Answer: A**



**Watch Video Solution**

**152.** An electric charge  $10^{-3} \mu C$  is placed at the origin  $(0, 0)$  of X-Y co-ordinate system. Two points A and B are situated at  $(\sqrt{2}, \sqrt{2})$  and  $(2, 0)$  respectively. The potential difference between the points A and B will be

A. 9 V

B. zero

C. 2 V

D. 3.5 V

**Answer: B**



[Watch Video Solution](#)

**153.** Two identical thin rings each of radius 10 cm carrying charges 10 C and 5 C are coaxially placed at a distance 10 cm apart. The work

done in moving a charge  $q$  from the centre of the first ring to that of the second is

A.  $\frac{q}{8\pi\epsilon_0} \cdot \left[ \frac{\sqrt{2} + 1}{\sqrt{2}} \right]$

B.  $\frac{q}{8\pi\epsilon_0} \cdot \left[ \frac{-\sqrt{2} + 1}{\sqrt{2}} \right]$

C.  $\frac{q}{4\pi\epsilon_0} \cdot \left[ \frac{\sqrt{2} + 1}{\sqrt{2}} \right]$

D.  $\frac{q}{4\pi\epsilon_0} \cdot \left[ \frac{\sqrt{2} - 1}{\sqrt{2}} \right]$

**Answer: B**



**Watch Video Solution**

**154.** Two equal charges  $q$  of opposite sign separated by a distance  $2a$  constitute an electric dipole of dipole moment  $p$ . If P is a point at a distance  $r$  from the centre of the dipole and the line joining the centre of the dipole to this point makes an angle  $\theta$  with the axis of

the dipole, then the potential at P is given by ( $r \gg 2a$ ) where

( $p = 2qa$ )

A.  $V = \frac{p \cos \theta}{4\pi\epsilon_0 r^2}$

B.  $V = \frac{p \cos \theta}{4\pi\epsilon_0 r}$

C.  $V = \frac{p \sin \theta}{4\pi\epsilon_0 r}$

D.  $V = \frac{p \cos \theta}{4\pi\epsilon_0 r^2}$

**Answer: B**



[View Text Solution](#)

**155.** The electrostatic potential  $\phi_r$ , of a spherical symmetrical system kept at origin, is shown in the adjacent figure, and given as

$$\phi_r = \frac{q}{4\pi\epsilon_0 r} (r \geq R_0)$$

$$\phi_r = \frac{q}{4\pi\epsilon_0 R_0} (r \leq R_0)$$



Which of the following option is incorrect ?



- A. For spherical region  $r \leq R_0$  total electrostatic energy stored is zero
- B. With in  $r = 2R_0$ , total charge is  $q/2$
- C. There will be no charge anywhere except at  $r = R$
- D. Electric field is discontinuous at  $r = R_0$

**Answer: B**



[View Text Solution](#)

**156.** An electric dipole when placed in a uniform electric field  $E$  will have minimum potential energy, if the positive direction of dipole moment makes the following angle with  $E$

A. zero

B.  $\frac{\pi}{2}$

C.  $\pi$

D.  $\frac{3\pi}{2}$

**Answer: A**



[Watch Video Solution](#)

**157.** Electric charges of  $+10\mu C$ ,  $+5\mu C$ ,  $-3\mu C$  and  $+8\mu C$  are placed at the corners of a square of side  $\sqrt{2}$  m, the potential at the centre of the square is

A. 1.8 V

B.  $1.8 \times 10^6 V$

C.  $1.8 \times 10^5 V$

D.  $1.8 \times 10^4 V$

**Answer: C**

 [Watch Video Solution](#)

**158.** The displacement of a charge  $Q$  in the electric field  $\vec{E} = e_1\hat{i} + e_2\hat{j} + e_3\hat{k}$  is  $\vec{r} = a\hat{i} + b\hat{j}$ . The work done is

A.  $Q(ae_1 + be_2)$

B.  $Q\sqrt{(ae_1)^2 + (be_2)^2}$

C.  $Q(e_1 + e_2)\sqrt{a^2 + b^2}$

D.  $Q\left(\sqrt{e_1^2 + e_2^2}\right)(a + b)$

**Answer: A**

 [Watch Video Solution](#)

**159.** Two electric charges  $12\mu C$  and  $-6\mu C$  are placed  $20\text{cm}$  apart in air. There will be a point  $P$  on the line joining these charges and outside the region between them, at which the electric potential is zero. The distance of  $P$  from  $6\mu C$  charge is

- A. 0.10 m
- B. 0.15 m
- C. 0.20 m
- D. 0.25 m

**Answer: C**



[Watch Video Solution](#)

**160.** In the rectangle, shown below, the two corners have charges  $q_1 = -5\mu C$  and  $q_2 = +2.0\mu C$ . The work done in moving a

charge  $+3.0\mu C$  from B to A is (take  $1/4\pi\epsilon_0 = 10^{10}\text{N}\cdot\text{m}^2/\text{C}^2$ )



A. 2.8 J

B. 3.5 J

C. 4.5 J

D. 5.5 J

**Answer: A**



[View Text Solution](#)

**161.** Electric potential at any point is  $V = -5x + 3y + \sqrt{15}z$ , then the magnitude of the electric field is

A.  $3\sqrt{2}$

B.  $4\sqrt{2}$

C.  $5\sqrt{2}$

D. 7

**Answer: D**



**Watch Video Solution**

**162.** A thin spherical conducting shell of radius  $R$  has a charge  $q$ . Another charge  $Q$  is placed at the centre of the shell. The electrostatic potential at a point  $P$  a distance  $\frac{R}{2}$  from the centre of the shell is

A.  $\frac{(q + Q)}{4\pi\epsilon_0} \frac{2}{R}$

B.  $\frac{2Q}{4\pi\epsilon_0 R}$

C.  $\frac{2Q}{4\pi\epsilon_0 R} - \frac{2q}{4\pi\epsilon_0 R}$

D.  $\frac{2Q}{4\pi\epsilon_0 R} + \frac{q}{4\pi\epsilon_0 R}$

Answer: D

 Watch Video Solution

163. In the given circuit, a charge of  $+80\mu C$  is given to the upper plate of the  $4\mu F$  capacitor. Then in the steady state, the charge on the upper plate of the  $3\mu F$  capacitor is

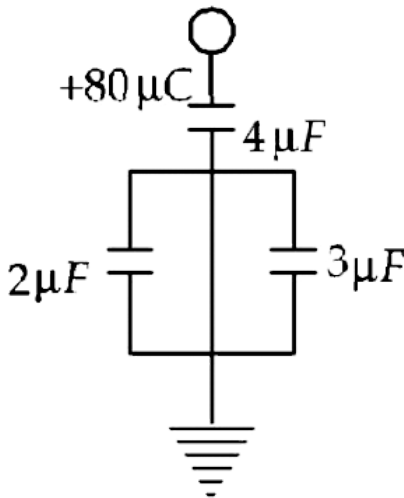

A.  $+32\mu C$

B.  $+40\mu C$

C.  $+48\mu C$

D.  $+80\mu C$

**Answer: C**

 [Watch Video Solution](#)

**164.** The capacitance of a capacitor between  $4/3$  times its original value if a dielectric slab of thickness  $t = d/2$  is inserted between the plates ( $d$  is the separation between the plates). What is the dielectric constant of the slab?

A. 8

B. 4

C. 6

D. 2

**Answer: D**



 [Watch Video Solution](#)

**165.** Point charge  $q_1 = 2\mu C$  and  $q_2 = -1\mu C$  are kept at points  $x = 0$  and  $x = 6$  respectively. Electrical potential will be zero at points

A.  $x = 2$  and  $x = 9$

B.  $x = 1$  and  $x = 5$

C.  $x = 4$  and  $x = 12$

D.  $x = -2$  and  $x = 2$

**Answer: C**

 [Watch Video Solution](#)

**166.** Eight small drops, each of radius  $r$  and having same charge  $q$  are combined to form a big drop. The ratio between the potentials

of the bigger drop and the smaller drop is

A. 8: 1

B. 4: 1

C. 2: 1

D. 1: 8

**Answer: B**



[Watch Video Solution](#)

**167.** Eight oil drops of same size are charged to a potential to 50 V each. These oil drops are merged into one single larged drop. What will be the potential of the large drop ?

A. 50 V

B. 100 V

C. 200 V

D. 400 V

**Answer: C**



**Watch Video Solution**

**168.** Three charges  $Q$ ,  $(+q)$  and  $(+q)$  are placed at the vertices of an equilateral triangle of side  $l$  as shown in the figure. It the net

electrostatic energy of the system is zero, then  $Q$  is equal to

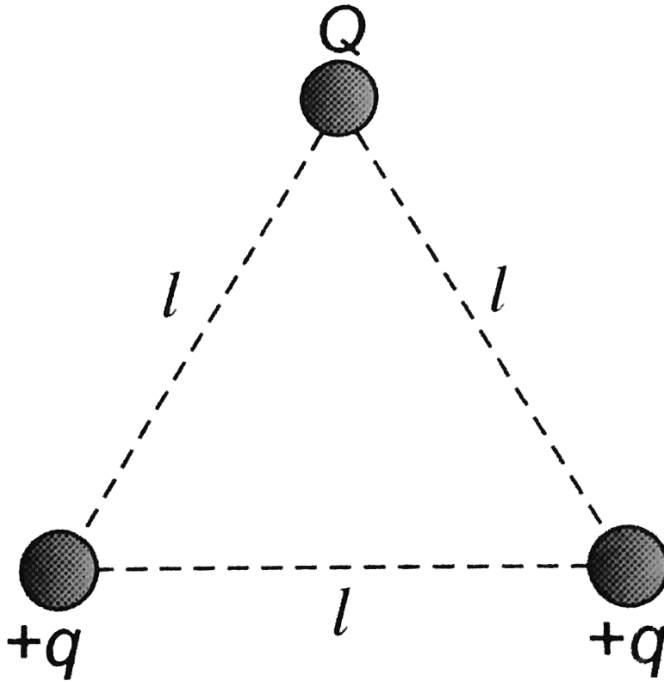

A.  $(-q/2)$

B.  $-q$

C.  $+q$

D. zero

**Answer: A**



**Watch Video Solution**

**169.** Consider a system composed of two metallic spheres of radii  $r_1$  and  $r_2$  connected by a thin wire and switch S as shown in the figure. Initially S is in open position. And the spheres carry charges  $q_1$  and  $q_2$  respectively. If the switch is closed, the potential of the system is



- A.  $\frac{1}{4\pi\epsilon_0} \frac{q_1 q_2}{r_1 r_2}$
- B.  $\frac{1}{4\pi\epsilon_0} \left( \frac{q_1 + q_2}{r_1 + r_2} \right)$
- C.  $\frac{1}{4\pi\epsilon_0} \left( \frac{q_1}{r_1} + \frac{q_2}{r_2} \right)$
- D.  $\frac{1}{4\pi\epsilon_0} \left( \frac{q_1 + q_2}{\sqrt{r_1 r_2}} \right)$

**Answer: B**



**View Text Solution**

170. Separation between the plates of a parallel plate capacitor is  $d$  and the area of each plates is  $A$ . When a slab of material of dielectric constant  $k$  and thickness  $t(t < d)$  is introduced between the plates. Its capacitance becomes

A. 
$$\frac{\epsilon_0 A}{d + t\left(1 - \frac{1}{K}\right)}$$

B. 
$$\frac{\epsilon_0 A}{d + t\left(1 + \frac{1}{K}\right)}$$

C. 
$$\frac{\epsilon_0 A}{d - t\left(1 - \frac{1}{K}\right)}$$

D. 
$$\frac{\epsilon_0 A}{d - t\left(1 + \frac{1}{K}\right)}$$

**Answer: C**



**Watch Video Solution**

171. The distance between the circular plates of a parallel plate condenser 40 mm in diameter, in order to have same capacity as a

sphere of radius 1 m is

A. 0.01 mm

B. 0.1 mm

C. 1.0 mm

D. 10 mm

**Answer: B**



**Watch Video Solution**

**172.** The expression for the capacity of the capacitor formed by compound dielectric placed between the plates of a parallel plate capacitor as shown in figure, will be (area of plate =  $A$ )



A. 
$$\frac{\epsilon_0 A}{\left( \frac{d_1}{K_1} + \frac{d_2}{K_2} + \frac{d_3}{K_3} \right)}$$

$$B. \frac{\epsilon_0 A}{\left( \frac{d_1 + d_2 + d_3}{K_1 + K_2 + K_3} \right)}$$

$$C. \frac{\epsilon_0 A (K_1 K_2 K_3)}{d_1 d_2 d_3}$$

$$D. \epsilon_0 \left( \frac{AK_1}{d_1} + \frac{AK_2}{d_2} + \frac{AK_3}{d_3} \right)$$

**Answer: A**



**View Text Solution**

**173.** The equivalent capacitance between A and B will be

A.  $|C|$  -  $|2C|$  -  $|4C|$  -  $|8C|$  -  $|\infty|$  - .B

A.  $2C$

B.  $\frac{C}{2}$

C.  $3C$

D.  $\frac{2}{C}$



Answer: B

 [View Text Solution](#)

174. Four plates of equal area  $A$  are separated by equal distance  $d$  and are arranged as shown in the figure. The equivalent capacity is

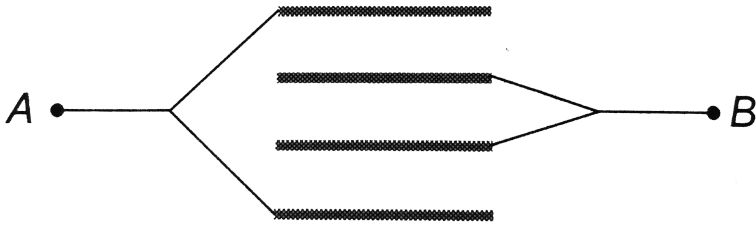

A.  $\frac{2\epsilon_0 A}{d}$

B.  $\frac{3\epsilon_0 A}{d}$

C.  $\frac{4\epsilon_0 A}{d}$

D.  $\frac{\epsilon_0 A}{d}$

Answer: A



175. Four plates of the same area of cross-section are joined as shown in the figure. The distance between each plate is  $d$ . The equivalent capacity across  $A$  and  $B$  will be

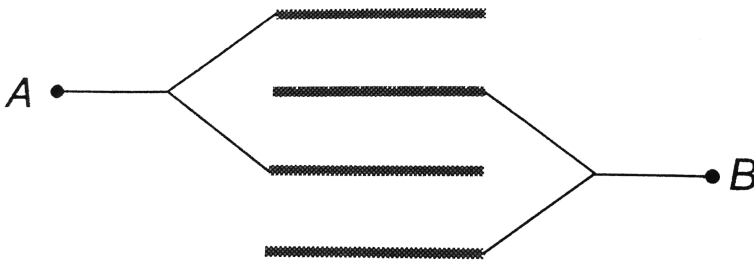

- A.  $\frac{2\varepsilon_0 A}{d}$
- B.  $\frac{3\varepsilon_0 A}{d}$
- C.  $\frac{3\varepsilon_0 A}{2d}$
- D.  $\frac{\varepsilon_0 A}{d}$

**Answer: B**

176. Three equal capacitors, each with capacitance  $C$  are connected as shown in figure. Then the equivalent capacitance between  $A$  and  $B$  is

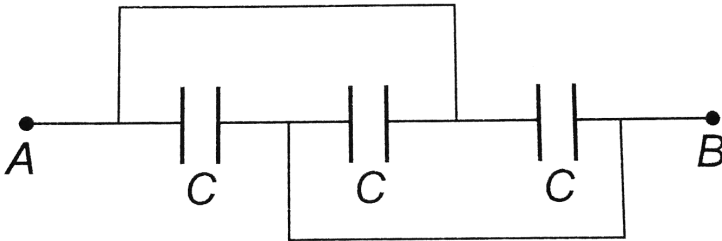

A.  $C$

B.  $3C$

C.  $\frac{C}{3}$

D.  $\frac{3C}{2}$

**Answer: B**



**Watch Video Solution**

177. If a slab of insulating material  $4 \times 10^{-5}$  m thick is introduced between the plates of a parallel plate capacitor, the distance between the plates has to be increased by  $3.5 \times 10^{-5}$  m to restore the capacity to original value. Then the dielectric constant of the material of slab is

- A. 6
- B. 8
- C. 10
- D. 12

**Answer: B**

 [Watch Video Solution](#)

178. In this figure the equivalent capacitance between A and B will be



A.  $\frac{C}{2}$

B.  $\frac{C}{3}$

C.  $3C$

D.  $2C$

**Answer: C**



[View Text Solution](#)

**179.** In the connection shown in the adjoining figure, the equivalent capacity between  $A$  and  $B$  will be

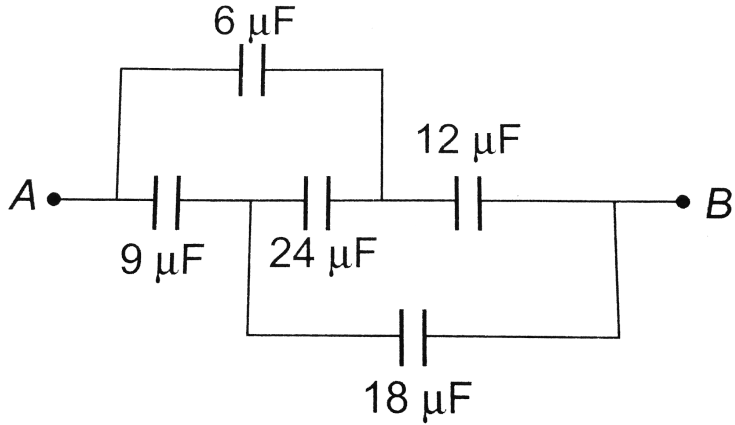

- A.  $10.8\ \mu\text{F}$
- B.  $69\ \mu\text{F}$
- C.  $15\ \mu\text{F}$
- D.  $10\ \mu\text{F}$

Answer: D

 [Watch Video Solution](#)

180. The resultant capacitance of given circuit between point P and Q is



A.  $3C$

B.  $2C$

C.  $C$

D.  $\frac{C}{3}$

**Answer: A**



[View Text Solution](#)

**181.** What is the effective capacitance between point A and B in the given figure?



A.  $1\mu F$

B.  $2\mu F$

C.  $1.5\mu F$

D.  $2.5\mu F$

Answer: B

 View Text Solution

182. In the figure a capacitor is filled with dielectrics  $K_1, K_2$  and  $K_3$ .

The resultant capacitance is:

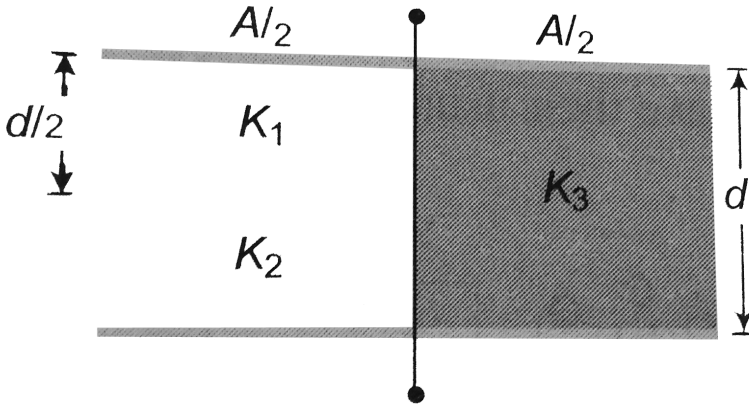

A.  $\frac{2\epsilon_0 A}{d} \left[ \frac{1}{K_1} + \frac{1}{K_2} + \frac{1}{K_3} \right]$

B.  $\frac{\epsilon_0 A}{d} \left[ \frac{1}{K_1} + \frac{1}{K_2} + \frac{1}{K_3} \right]$



C.  $\frac{2\varepsilon_0 A}{d} [K_1 + K_2 + K_3]$

D. None of these

**Answer: D**



**Watch Video Solution**

**183.** Four metallic plates each with a surface area  $A$  of one side and placed at a distance  $d$  from each other. the plates are connected as shown in the fig. Then the capacitance of the system between a and

b is -

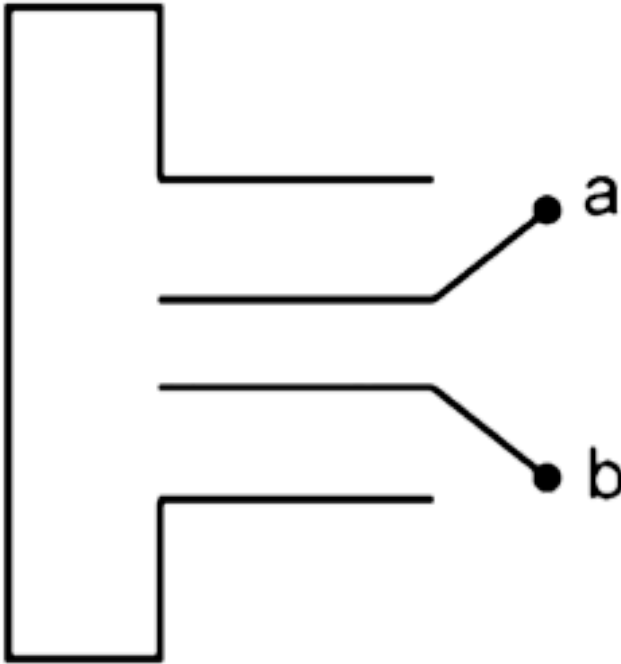

A.  $\frac{3\epsilon_0 A}{d}$

B.  $\frac{2\epsilon_0 A}{d}$

C.  $\frac{2\epsilon_0 A}{3d}$

D.  $\frac{3\epsilon_0 A}{2d}$

Answer: D



Watch Video Solution

**184.** The equivalent capacitance between A and B in the circuit will be



A.  $10/3\mu F$

B.  $4\mu F$

C.  $6\mu F$

D.  $8\mu F$

**Answer: D**



[View Text Solution](#)

**185.** The equivalent capacitance between the point A and C is given by



A.  $\frac{10}{3}C$

B.  $15C$

C.  $\frac{3}{10}C$

D.  $20C$

**Answer: B**



[View Text Solution](#)

**186.** Potential difference between two points  $(V_A - V_B)$  in an electric field  $E = (2\hat{i} - 4\hat{j})N/C$ , where  $A = (0, 0)$  and  $B = (3m, 4m)$  is

A.  $10V$

B.  $-10V$

C.  $16V$

D.  $-16V$

**Answer: B**



**Watch Video Solution**

**187.** A and B are two thin concentric hollow conductors having radii  $a$  and  $2a$  and charge  $2Q$  and  $Q$ , respectively. If potential of outer sphere is  $5V$ , then potential of inner sphere is

A.  $20 V$

B.  $10 V$

C.  $\frac{25}{3} V$

D.  $\frac{50}{3} V$

**Answer: C**

 [Watch Video Solution](#)

**188.** A spherical conductor of radius  $2m$  is charged to a potential of  $120V$ . It is now placed inside another hollow spherical conductor of radius  $6m$ . Calculate the potential to which the bigger sphere would be raised

A.  $120\text{ V}$

B.  $60\text{ V}$

C.  $80\text{ V}$

D.  $40\text{ V}$

**Answer: D**

 [Watch Video Solution](#)

**189.** In Millike's oil drop experiment an oil drop carrying a charge  $Q$  is held stationary by a potential difference  $2400V$  between the plates. To keep a drop of half the radius stationary the potential difference had to be made  $600V$ . What is the charge on the second drop ?

A.  $\frac{Q}{4}$

B.  $\frac{Q}{2}$

C.  $Q$

D.  $\frac{3Q}{2}$

**Answer: B**



**Watch Video Solution**

**190.** There are four concentric shells A, B, C and D of radii  $a$ ,  $2a$ ,  $3a$  and  $4a$  respectively. Shells B and D are given charges  $+q$  and  $-q$  respectively. Shell C is now earthed. The potential difference

$$V_A - V_C \text{ is } k = \left( \frac{1}{4\pi\epsilon_0} \right)$$

A.  $\frac{Kq}{2a}$

B.  $\frac{Kq}{3a}$

C.  $\frac{Kq}{4a}$

D.  $\frac{Kq}{6a}$

**Answer: D**



**Watch Video Solution**

**191.** A solid conducting sphere having a charge  $Q$  is surrounded by an uncharged concentric conducting hollow spherical shell. Let the



potential difference between the surface of the solid sphere and that of the outer surface of the hollow shell be  $V$ . If the shell is now given a charge of  $-3Q$ , the new potential difference between the same two surfaces is :

- A.  $V$
- B.  $2V$
- C.  $4V$
- D.  $-2V$

**Answer: A**



[Watch Video Solution](#)

**192.** A point charge  $q$  is placed at a distance of  $r$  from the centre  $O$  of an uncharged spherical shell of inner radius  $R$  and outer radius

2R. The electric potential at the centre of the shell will be



A.  $\frac{q}{4\pi\epsilon_0} \left( \frac{1}{r} - \frac{1}{2R} \right)$

B.  $\frac{q}{4\pi\epsilon_0 r}$

C.  $\frac{q}{4\pi\epsilon_0} \left( \frac{1}{r} + \frac{1}{2R} \right)$

D.  $\frac{q}{4\pi\epsilon_0} \left( \frac{1}{r} - \frac{1}{R} \right)$

**Answer: A**



**Watch Video Solution**

**193.** A hollow sphere of radius  $r$  is put inside another hollow sphere of radius  $R$ . The charges on the two are  $+Q$  and  $-q$  as shown in the figure. A point  $P$  is located at a distance  $x$  from the common centre such that  $r < x < R$ . The potential at the point  $P$  is

A.  $\frac{1}{4\pi\epsilon_0} \left( \frac{Q - q}{x} \right)$

$$B. \frac{1}{4\pi\epsilon_0} \left( \frac{Q}{R} - \frac{q}{r} \right)$$

$$C. \frac{1}{4\pi\epsilon_0} \left( \frac{Q}{R} - \frac{q}{x} \right)$$

$$D. \frac{1}{4\pi\epsilon_0} \left( \frac{q}{r} - \frac{Q}{x} \right)$$

Answer: C

 Watch Video Solution

**194.** Three plates  $A, B, C$  each of area  $50\text{cm}^2$  have separation  $3\text{mm}$  between  $A$  and  $B$  and  $3\text{mm}$  between  $B$  and  $C$ . The energy stored when the plates area fully charged is

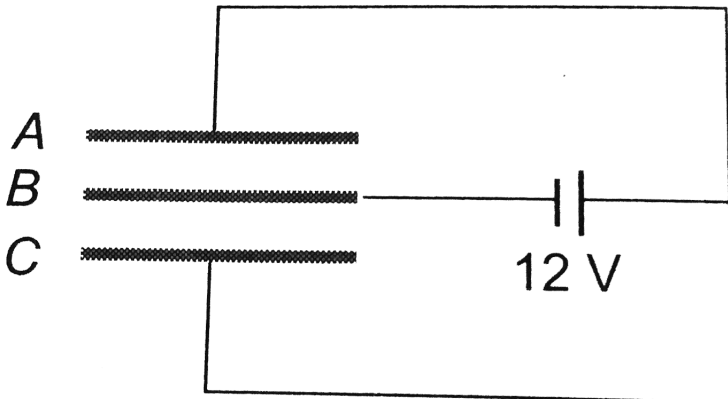

A.  $1.6 \times 10^{-9} J$

B.  $2.1 \times 10^{-9} J$

C.  $5 \times 10^{-9} J$

D.  $7 \times 10^{-9} J$

**Answer: B**



**Watch Video Solution**

**195.** A parallel plate capacitor with air as medium between the plates has a capacitance of  $10\mu F$ . The area of capacitor is divided into two equal halves and filled with two media as shown in the figure having dielectric constnt  $k_1 = 2$  and  $k_2 = 4$ . the capacitance

of the system will now be

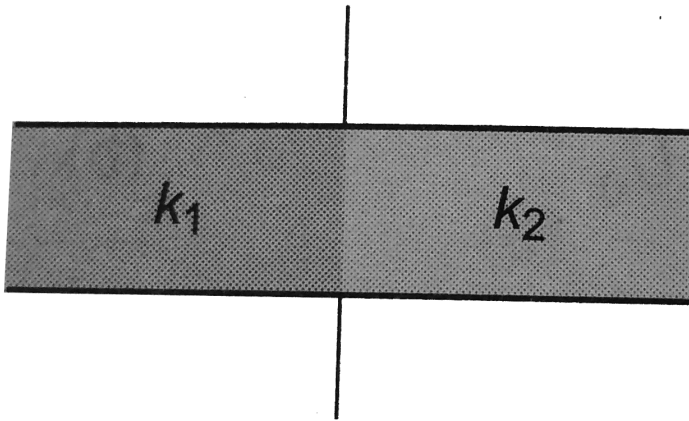

A.  $10\mu F$

B.  $20\mu F$

C.  $30\mu F$

D.  $40\mu F$

**Answer: C**



**Watch Video Solution**

196. The capacities and connection of five capacitors are shown in the adjoining figure. The potential difference between the points  $A$  and  $B$  is 60 volts. Then the equivalent capacity between  $A$  and  $B$  and the charge on  $5\mu F$  capacitance will be respectively

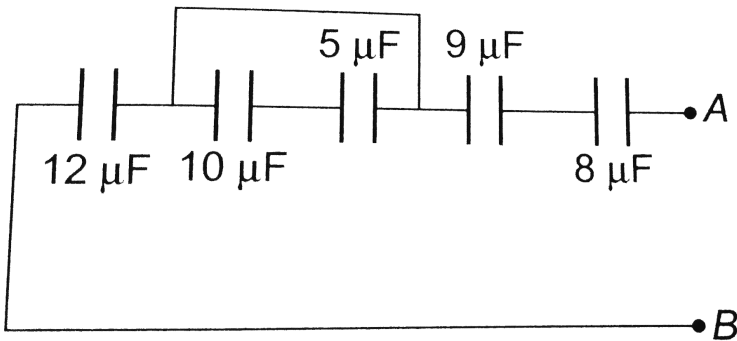

- A.  $44\mu F, 300\mu C$
- B.  $15\mu F, 150\mu C$
- C.  $15\mu F, 200\mu C$
- D.  $4\mu C, 50\mu C$

Answer: D

 Watch Video Solution

197. A charge  $+Q$  is uniformly distributed over a thin ring of the radius  $R$ . The velocity of an electron at the moment when it passes through the centre  $O$  of the ring, if the electron was initially at far away on the axis of the ring is ( $m$ =mass of electron,  $K = \frac{1}{4\pi\epsilon_0}$ )

A.  $\sqrt{\left(\frac{2KQe}{mR}\right)}$

B.  $\sqrt{\left(\frac{Kqe}{m}\right)}$

C.  $\sqrt{\left(\frac{Kme}{QR}\right)}$

D.  $\sqrt{\left(\frac{Kqe}{mR}\right)}$

**Answer: A**

 [Watch Video Solution](#)

**198.** A parallel plate capacitor of capacitance  $C$  is connected to a battery and is charged to a potential difference  $V$ . Another capacitor of capacitance  $2C$  is isimilarly charged to a potential difference  $2V$ . The charging battery is now disconnected and the capacitors are connected in parallel to each other in such a way that the poistive terminal of one is connected to the negative terminal of the other. The final energy of the configuration is

A. zero

B.  $\frac{25CV^2}{6}$

C.  $\frac{3CV^2}{2}$

D.  $\frac{9CV^2}{2}$

**Answer: C**



**Watch Video Solution**



199. Condenser  $A$  has a capacity of  $15\mu F$  when it is filled with a medium of dielectric constant 15. Another condenser  $B$  has a capacity  $1\mu F$  with air between the plates. Both are charged separately by a battery of  $100V$ . After charging, both are connected in parallel without the battery and the dielectric material being removed. The common potential now is

A. 400 V

B. 800 V

C. 1200 V

D. 1600 V

**Answer: B**



**Watch Video Solution**

200. In the given if point C is connected to the earth and a potential of +2000 V is given to the point A, the potential at B is



- A. 1500 V
- B. 1000 V
- C. 500 V
- D. 400 V

**Answer: C**

 [View Text Solution](#)

201. A network of four capacitors of capacity equal to  $C_1 = C$ ,  $C_2 = 2C$ ,  $C_3 = 3C$  and  $C_4 = 4C$  are connected to a battery as shown in the figure. The ratio of the charges on  $C_2$  and

$C_4$  is

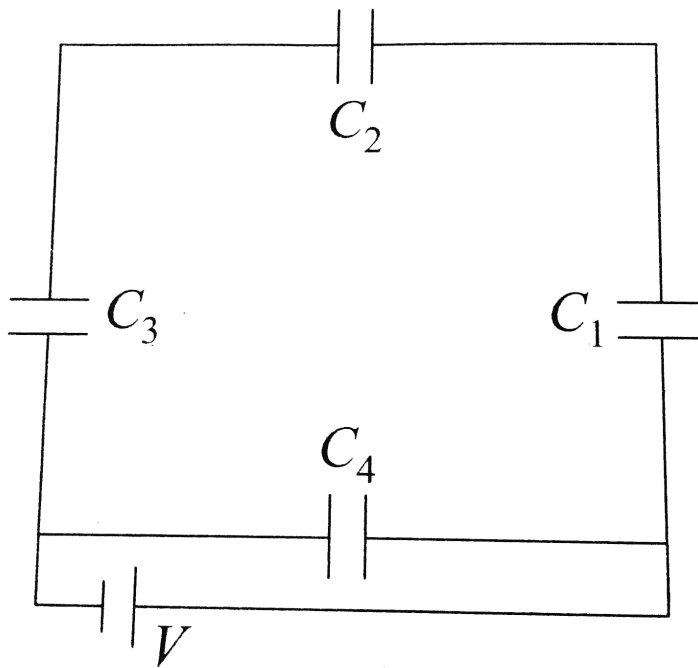

- A.  $\frac{22}{3}$
- B.  $\frac{3}{22}$
- C.  $\frac{7}{4}$
- D.  $\frac{4}{7}$

Answer: B



Watch Video Solution

202. Figures shows three spherical and equipotential surfaces 1, 2 and 3 round a point charge  $q$ . The potential difference  $v_1 - v_2 = V_2 - V_3$  if  $t_1$  and  $t_2$  be the distance between them, then

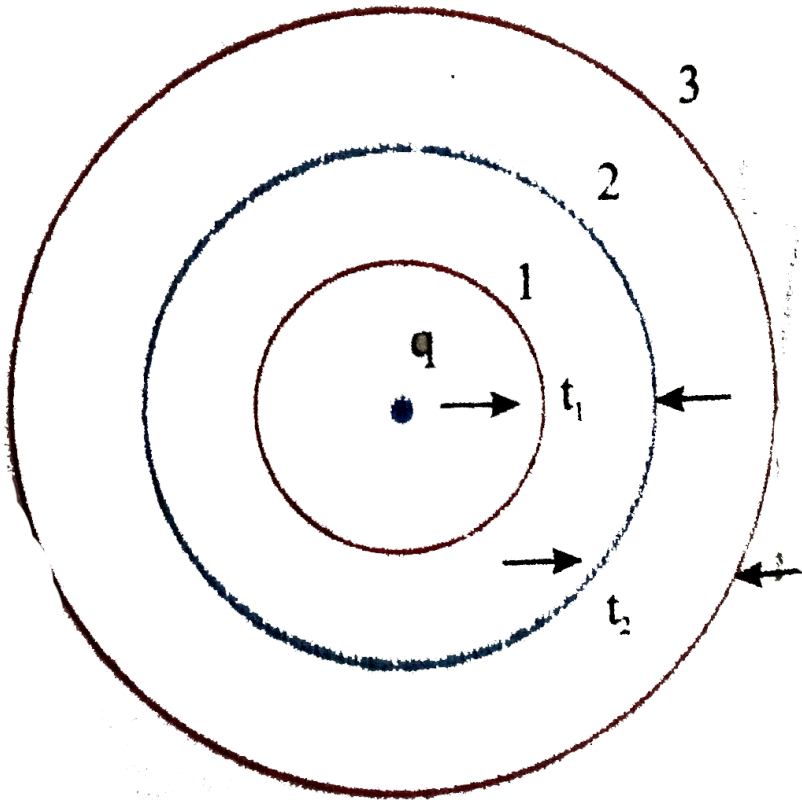

A.  $t_1 = t_2$

B.  $t_1 > t_2$

C.  $t_1 < t_2$

D.  $t_1 \leq t_2$

**Answer: C**

 [Watch Video Solution](#)

**203.** A charged oil drop of mass  $2.5 \times 10^{-7} \text{ kg}$  is in space between the two plates, each of area  $2 \times 10^{-2} \text{ m}^2$  of a parallel plate capacitor. When the upper plate has a charge of  $5 \times 10^{-7} \text{ C}$  and the lower plate has an equal negative charge, then the oil remains stationary. the charge of the oil drop is (take,  $g = 10 \text{ m} / \text{s}^2$ )

A.  $9 \times 10^{-1} \text{ C}$

B.  $9 \times 10^{-6} \text{ C}$

C.  $8.85 \times 10^{-13} \text{ C}$

D.  $1.8 \times 10^{-14} \text{ C}$

Answer: C

 Watch Video Solution

204. A capacitor of  $4\mu F$  is connected as shown in the circuit. The internal resistance of the battery is  $0.5\Omega$ . The amount of charge on the capacitor plates will be

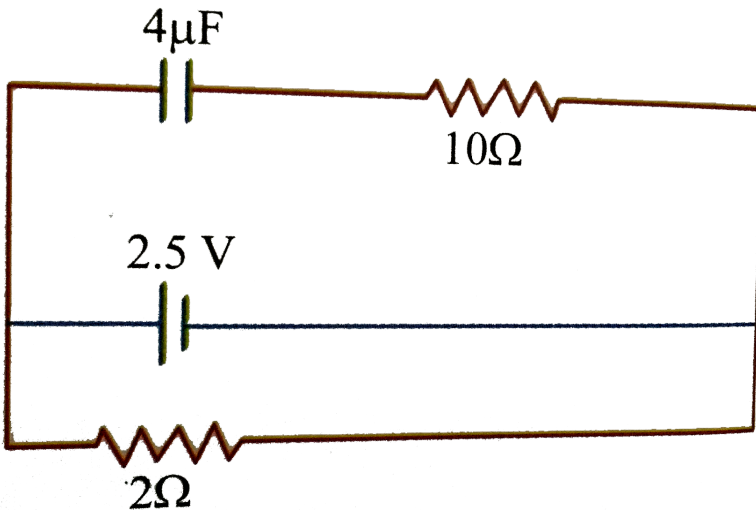

A. 0

B.  $4\mu C$

C.  $16\mu C$

D.  $8\mu\text{C}$

Answer: D

 Watch Video Solution

205. A parallel plate capacitor is made of two dielectric blocks in series. One of the blocks has thickness  $d_1$  and dielectric constant  $K_1$  and the other has thickness  $d_2$  and dielectric constant  $K_2$  as shown in figure. This arrangement can be through as a dielectric slab of thickness  $d( = d_1 + d_2)$  and effective dielectric constant  $K$ .

The  $K$  is.

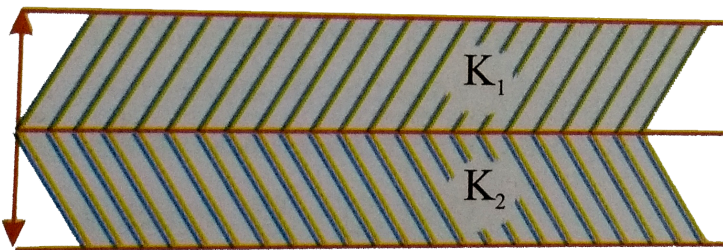

A. 
$$\frac{K_1 d_1 + K_2 d_2}{d_1 + d_2}$$

B.  $\frac{K_1d_1 + K_2d_2}{K_1 + K_2}$

C.  $\frac{K_1K_2(d_1 + d_2)}{(K_1d_2 + K_2d_1)}$

D.  $\frac{2K_1K_2}{K_1 + K_2}$

**Answer: C**



**Watch Video Solution**

**206.** A number of capacitors each of capacitance  $1\mu F$  and each one of which get punctured if a potential difference just exceeding 500 volt is applied, are provided. Then an arrangement suitable for giving a capacitor of  $2\mu F$  across which 3000 volt may be applied requires at least-

A. 6 component capacitors

B. 12 component capacitors

C. 72 component capacitors



## D. 2 component capacitors

Answer: C

 [Watch Video Solution](#)

**207.** A series combination of  $n_1$  capacitors, each of value  $C_1$ , is charged by a source of potential difference  $4V$ . When another parallel combination of  $n_2$  capacitors, each of value  $C_2$ , is charged by a source of potential difference  $V$ , it has same (total) energy stored in it, as the first combination has. the value of  $C_2$ , in terms of  $C_1$ , is then

A.  $\frac{2C_1}{n_1 n_2}$

B.  $16\frac{n_1}{n_2}C_1$

C.  $2\frac{n_2}{n_1}C_1$

D.  $\frac{16C_1}{n_1 n_2}$

**Answer: D**



**Watch Video Solution**

**208.** Two charges  $+6\mu C$  and  $-4\mu C$  are placed 15 cm apart as shown. At what distance from A to its right the electrostatic potential is zero (distances in cm)



- A. 4, 9, 60
- B. 9, 45, infinity
- C. 20, 45, infinity
- D. 9, 15, 45

**Answer: B**



**Watch Video Solution**

**209.** Assume that an electric field  $\vec{E} = 30x^2\hat{i}$  exists in space. Then the potential differences  $V_A - V_0$  where  $V_0$  is the potential at the origin and  $V_A$ , the potential at  $x = 2m$  is

- A. 120 V
- B.  $-120V$
- C.  $-80V$
- D. 80V

**Answer: C**

 [Watch Video Solution](#)

**210.** An electron initially at rest falls a distance of 1.5 cm in a uniform electric field of magnitude  $2 \times 10^4 N/C$ . The time taken by the electron to fall this distance is

A.  $1.3 \times 10^2 s$

B.  $2.1 \times 10^{-2} s$

C.  $1.6 \times 10^{-10} s$

D.  $2.9 \times 10^{-9} s$

**Answer: D**



**Watch Video Solution**

**211.** A long, hollow conducting cylinder is kept coaxially inside another long, hollow conducting cylinder of larger radius. Both the cylinders are initially electrically neutral.

A. A potential difference appears between the two cylinders when a charge density is given to the inner cylinder

- B. A potential difference appears between the two cylinders when a charge density is given to the outer cylinder
- C. No potential difference appears between the two cylinders when a uniform line charge is kept along the axis of the cylinders
- D. No potential difference appears between the two cylinders when same charge density is given to both the cylinders

**Answer: A**

 [Watch Video Solution](#)

**212.** The potential at a point  $x$  ( measured in  $\mu\text{ m}$ ) due to some charges situated on the  $x$ -axis is given by

$$V(x) = 20 / (x^2 - 4) \text{ volt}$$

- A.  $5/3$  volt/ $\mu\text{m}$  and in the negative x-direction
- B.  $5/3$  volt/ $\mu\text{m}$  and in the positive x-direction
- C.  $10/9$  volt/ $\mu\text{m}$  and in the negative x-direction
- D.  $10/9$  volt/ $\mu\text{m}$  and in the positive x-direction

**Answer: D**

 [Watch Video Solution](#)

**213.** Three charges  $Q$ ,  $+q$  and  $+q$  are placed at the vertices of a right-angled isosceles triangle as shown. The net electrostatic

energy of the configuration is zero if  $Q$  is equal to

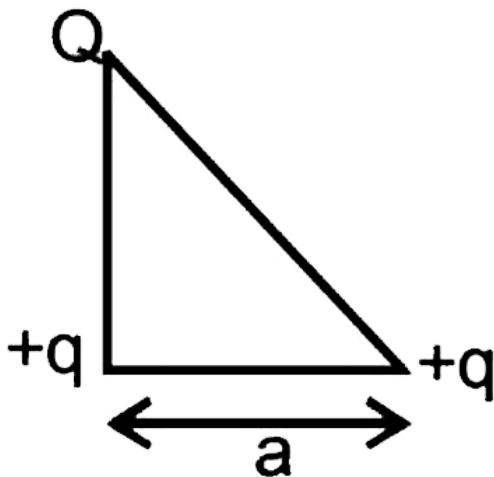

A.  $\frac{-q}{1 + \sqrt{2}}$

B.  $\frac{-2q}{2 + \sqrt{2}}$

C.  $-2q$

D.  $+q$

**Answer: B**



**Watch Video Solution**

214. Four point charges each  $+q$  is placed on the circumference of a circle of diameter  $2d$  in such a way that they form a square. The potential at the centre is

A. 0

B.  $\frac{4kq}{d}$

C.  $\frac{4d}{q}$

D.  $\frac{q}{4d}$

**Answer: B**



**Watch Video Solution**

215. The resultant capacitance between  $A$  and  $B$  in the following figure is equal to



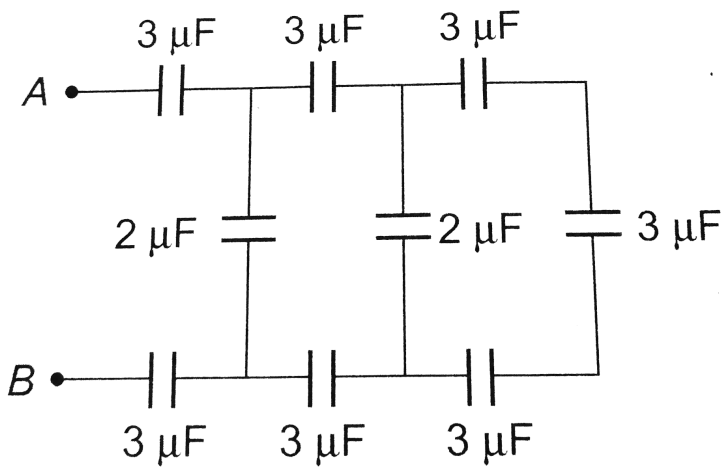

- A.  $1\mu F$
- B.  $3\mu F$
- C.  $2\mu F$
- D.  $1.5\mu F$

**Answer: A**

Watch Video Solution

216. In the following circuit, the resultant capacitance between  $A$  and  $B$  is  $1\mu F$ . Then value of  $C$  is

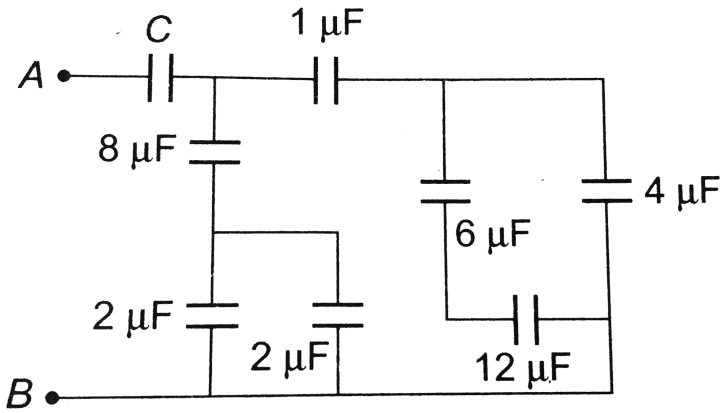

- A.  $\frac{32}{11}\mu F$
- B.  $\frac{11}{32}\mu F$
- C.  $\frac{23}{32}\mu F$
- D.  $\frac{32}{23}\mu F$

Answer: D

 Watch Video Solution

217. A small conducting sphere of radius  $r$  is lying concentrically inside a bigger hollow conducting sphere of radius  $R$ . The bigger and smaller spheres are charged with  $Q$  and  $q(Q > q)$  and are insulated from each other. The potential difference between the spheres will be

A.  $\frac{1}{4\pi\epsilon_0} \left( \frac{q}{r} - \frac{Q}{R} \right)$

B.  $\frac{1}{4\pi\epsilon_0} \left( \frac{Q}{R} + \frac{q}{r} \right)$

C.  $\frac{1}{4\pi\epsilon_0} \left( \frac{q}{r} - \frac{r}{R} \right)$

D.  $\frac{1}{4\pi\epsilon_0} \left( \frac{q}{R} - \frac{Q}{r} \right)$

**Answer: C**



**Watch Video Solution**

218. A parallel plate air capacitor has a capacitance  $C$ . When it is half filled with a dielectric of dielectric constant 5, then the percentage

increase in the capacitance will be



- A. 400 %
- B. 66.6 %
- C. 33.3 %
- D. 200 %

**Answer: A**



[View Text Solution](#)

**219.** Charge  $Q$  is uniformly distributed on a dielectric rod  $AB$  of length  $2l$ . The potential at  $P$  shown in the figure is equal to



A. 
$$\frac{Q}{4\pi\epsilon_0(2l)}$$

B.  $\frac{Q}{4\pi\epsilon_0(l)} \ln 2$

C.  $\frac{Q}{4\pi\epsilon_0(2l)} \ln 3$

D. None of these

**Answer: C**



**View Text Solution**

**220.** The arc AB with the centre C and the infinitely long wire having linear charge density  $\lambda$  are lying in the same plane. The minimum amount of work to be done to move a point charge  $q_0$  from point A to B through a circuit path AB of radius a is equal to



A.  $\frac{q_0\lambda}{4\pi\epsilon_0} \ln\left(\frac{2}{3}\right)$

B.  $\frac{q_0\lambda}{2\pi\epsilon_0} \ln\left(\frac{3}{2}\right)$

C.  $\frac{q_0\lambda}{2\pi\epsilon_0} \ln\left(\frac{2}{3}\right)$

D. None of these

Answer: B

 [View Text Solution](#)

221. Two charges  $q_1$  and  $q_2$  are placed  $30\text{cm}$  apart, as shown in the figure. A third charge  $q_3$  is moved along the arc of a circle of radius  $40\text{cm}$  from  $C$  to  $D$ . The change in the potential energy of the system is  $\frac{q_3}{4\pi\epsilon_0} k$ , where  $k$  is

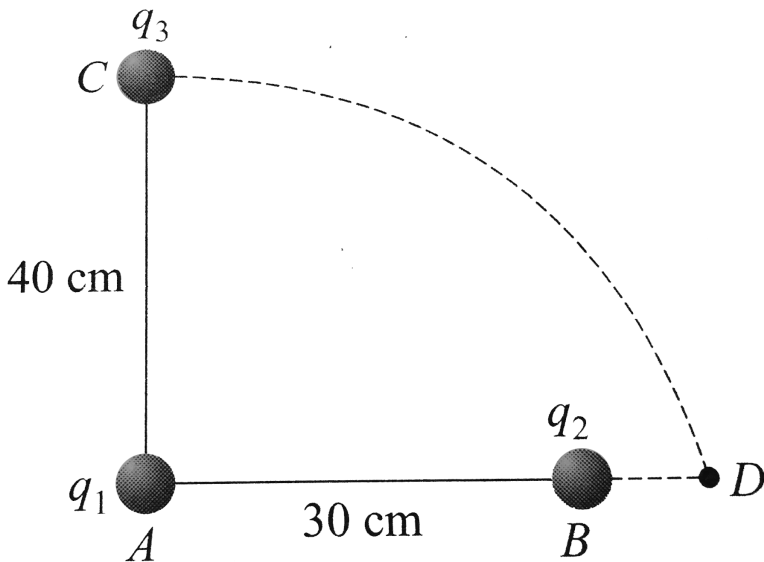

A.  $8q_2$

B.  $8q_1$

C.  $6q_2$

D.  $6q_1$

**Answer: A**

 [Watch Video Solution](#)

**222.** Three identical metallic uncharged spheres A, B and C of radius  $a$  are kept on the corners of an equilateral triangle of side  $d$  ( $d > 2a$ ). A fourth sphere (radius  $a$ ) which has charge  $Q$  touches A and is then removed to a position far away. B is earthed and then the earth connection is removed. C is then earthed. The charge on C is

A.  $\frac{Qa}{2d} \left( \frac{2d - a}{2d} \right)$

B.  $\frac{Qa}{2d} \left( \frac{2d - a}{d} \right)$

C.  $\frac{Qa}{2d} \left( \frac{a - d}{d} \right)$

D.  $\frac{2Qa}{d} \left( \frac{d - a}{2d} \right)$

Answer: C

 Watch Video Solution

223. The curve represents the distribution of potential along the straight line joining the two charges  $Q_1$  and  $Q_2$  (separated by a distance  $r$ ) then which of the following statements are correct?

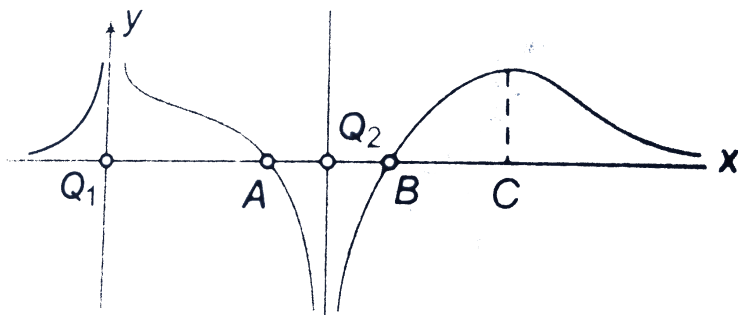

1.  $|Q_1| > |Q_2|$



2.  $Q_1$  is positive in nature
3. A and B are equilibrium points
4. C is a point of unstable equilibrium

- A. 1 and 2
- B. 1, 2 and 3
- C. 1, 2 and 4
- D. 1, 2, 3 and 4

**Answer: C**

 [Watch Video Solution](#)

**224.** Seven capacitors each of capacity  $2\mu F$  are to be so connected to have a total capacity  $(10/1)\mu F$ . Which will be the necessary figure as shown?

A. 

B. 

C. 

D. 

**Answer: A**



[View Text Solution](#)

**225.** A solid conducting sphere of radius  $a$  having a charge  $q$  is surrounded by a concentric conducting spherical shell of inner radius  $2a$  and outer radius  $3a$  as shown in figure. Find the amount

of heat produced when switch is closed  $\left(k = \frac{1}{4\pi\epsilon_0}\right)$

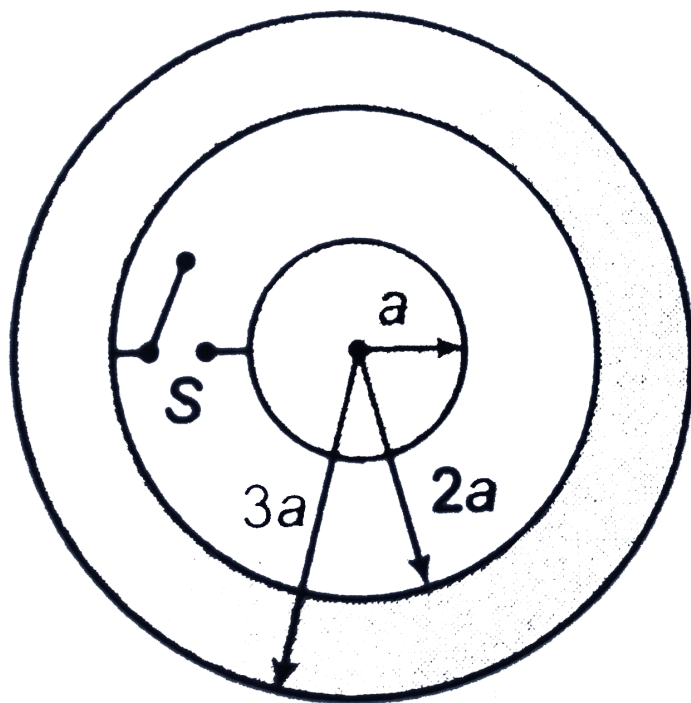

- A.  $\frac{Kq^2}{2a}$
- B.  $\frac{Kq^2}{3a}$
- C.  $\frac{Kq^2}{4a}$
- D.  $\frac{Kq^2}{6a}$

**Answer: C**



**226.** Three identical charges are placed at corners of an equilateral triangle of side  $l$ . If force between any two charges is  $F$ , the work required to double the dimensions of triangle is

A.  $-3Fl$

B.  $3Fl$

C.  $\left(-\frac{3}{2}\right)Fl$

D.  $\left(\frac{3}{2}\right)Fl$

**Answer: C**



**227.** Two capacitors  $C_1$  and  $C_2 = 2C_1$  are connected in a circuit with a switch between them as shown in the figure- 3.302. Initially

the switch is open and  $C_1$  holds charge  $Q$ . The switch is closed. In steady state, the charge on the two capacitors will be given as :

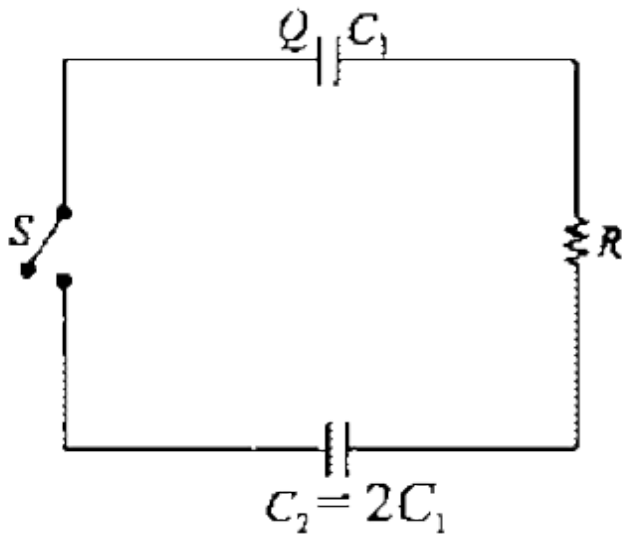

- A.  $Q, 2Q$
- B.  $Q/3, 2Q/3$
- C.  $3Q/2, 3Q$
- D.  $2Q/3, 4Q/3$

**Answer: B**

 [Watch Video Solution](#)

228. Five identical plates each of area  $a$  are joined as shown in the figure. The distance between the plates is  $d$ . The plates are connected to a potential difference of  $V$  volt. The charge on plates 1 and 4 will be



A.  $-\frac{\epsilon_0 AV}{d} \cdot \frac{2\epsilon_0 AV}{d}$

B.  $\frac{\epsilon_0 AV}{d} \cdot \frac{2\epsilon_0 AV}{d}$

C.  $\frac{\epsilon_0 AV}{d} \cdot \frac{-2\epsilon_0 AV}{d}$

D.  $\frac{-\epsilon_0 AV}{d} \cdot \frac{-2\epsilon_0 AV}{d}$

**Answer: C**



[View Text Solution](#)

229. In the figure shown, what is the potential difference between the points A and B between a and C respectively in steady state?



A.  $V_{AB} = V_{BC} = 100V$

B.  $V_{AB} = 75V, V_{BC} = 25V$

C.  $V_{AB} = 25V, V_{BC} = 75V$

D.  $V_{AB} = V_{BC} = 50V$

**Answer: C**



[View Text Solution](#)

**(B) Chapter exercises**

1. Assertion : Due to two point charges electric field and electric potential can't be zero at some point simultaneously.

Reason : Field is a vector quantity and potential a scalar quantity.

A. If both Assertion and Reason are true and Reason is the correct explanation of Assertion.

B. If both Assertion and Reason are true but Reason is not correct explanation of Assertion.

C. If Assertion is true but Reason is false.

D. If Assertion is false but Reason is true.

**Answer: B**



**Watch Video Solution**



2. Assertion: Conductors having equal positive charge and volume, must also have same potential.

Reason: Potential depends only on charge and volume of conductor.

- A. If both Assertion and Reason are true and Reason is the correct explanation of Assertion.
- B. If both Assertion and Reason are true but Reason is not correct explanation of Assertion.
- C. If Assertion is true but Reason is false.
- D. If both Assertion and Reason are false.

**Answer: D**

 [Watch Video Solution](#)

3. Assertion: Circuit containing capacitors should be handled cautiously even when there is no current.

Reason: The capacitors are very delicate and so quickly break down.

- A. If both Assertion and Reason are true and Reason is the correct explanation of Assertion.
- B. If both Assertion and Reason are true but Reason is not correct explanation of Assertion.
- C. If Assertion is true but Reason is false.
- D. If Assertion is false but Reason is true.

**Answer: C**

 [Watch Video Solution](#)

4. Assertion : When two positive point charges move away from each other, then their electrostatic potential energy decreases.

Reason : Change in potential energy between two points is equal to the work done by electrostatic forces.

A. If both Assertion and Reason are true and Reason is the correct explanation of Assertion.

B. If both Assertion and Reason are true but Reason is not correct explanation of Assertion.

C. If Assertion is true but Reason is false.

D. If Assertion is false but Reason is true.

**Answer: B**



[Watch Video Solution](#)

5. Assertion : When two charged spheres are connected to each other by a thin conducting wire, charge flow bigger sphere to smaller sphere, if initial charges on them are same.

Reason : Electrostatic potential energy will be lost in redistribution of charges.

A. If both Assertion and Reason are true and Reason is the correct explanation of Assertion.

B. If both Assertion and Reason are true but Reason is not correct explanation of Assertion.

C. If Assertion is true but Reason is false.

D. If Assertion is false but Reason is true.

**Answer: D**



[View Text Solution](#)

6. Assertion : For a non-uniformly charged thin circular ring with net charge zero, the electric field at any point on axis of the ring is zero.

Reason : For a non-uniformly charged thin circular ring with net charge zero, the electric potential at each point on axis of the ring is zero.

A. If both Assertion and Reason are true and Reason is the correct explanation of Assertion.

B. If both Assertion and Reason are true but Reason is not correct explanation of Assertion.

C. If Assertion is true but Reason is false.

D. If Assertion is false but Reason is true.

**Answer: D**



[View Text Solution](#)

7. Assertion : Five charges  $+q$  each are placed at five vertices of a regular pentagon. A sixth charge  $-Q$  is placed at the centre of pentagon. Then, net electrostatic force on  $-Q$  is zero.

Reason : Net electrostatic potential at the centre is zero.

- A. If both Assertion and Reason are true and Reason is the correct explanation of Assertion.
- B. If both Assertion and Reason are true but Reason is not correct explanation of Assertion.
- C. If Assertion is true but Reason is false.
- D. If Assertion is false but Reason is true.

**Answer: C**



[View Text Solution](#)

8. Assertion : A charged capacitor is disconnected from a battery.

Now, if its plate are separated further, the potential energy will fall.

Reason : Energy stored in a capacitor is equal to the work done in charging it.

A. If both Assertion and Reason are true and Reason is the correct explanation of Assertion.

B. If both Assertion and Reason are true but Reason is not correct explanation of Assertion.

C. If Assertion is true but Reason is false.

D. If Assertion is false but Reason is true.

**Answer: D**



[View Text Solution](#)

9. Assertion : When a capacitor is charged by a battery. Half of the energy supplied by the battery is stored in the capacitor and rest half is lost.

Reason : If resistance in the circuit is zero, then there will be no loss of energy.

- A. If both Assertion and Reason are true and Reason is the correct explanation of Assertion.
- B. If both Assertion and Reason are true but Reason is not correct explanation of Assertion.
- C. If Assertion is true but Reason is false.
- D. If Assertion is false but Reason is true.

**Answer: C**



[View Text Solution](#)



**10. Assertion :** When a metallic plate is partially inserted between the plates of a capacitor its capacity increases.

**Reason :** If conductivity of conducting plate is more, then increase in capacity will be more.

A. If both Assertion and Reason are true and Reason is the correct explanation of Assertion.

B. If both Assertion and Reason are true but Reason is not correct explanation of Assertion.

C. If Assertion is true but Reason is false.

D. If Assertion is false but Reason is true.

**Answer: C**



**View Text Solution**

**11. Assertion :** If the distance between parallel plates of a capacitor is halved and dielectric constant is made three times, then the capacitance becomes 6 times.

**Reason :** Capacity of the capacitor depends upon the nature of the material between the plates.

- A. If both Assertion and Reason are true and Reason is the correct explanation of Assertion.
- B. If both Assertion and Reason are true but Reason is not correct explanation of Assertion.
- C. If Assertion is true but Reason is false.
- D. If Assertion is false but Reason is true.

**Answer: B**



**Watch Video Solution**

12. Assertion : Spherical shell a in the shown figure has a charge  $-q$  and shell B has charge  $+q$ . When these two are connected by a thin conducting wire, then whole of the electrostatic potential energy stored between the shell is lost.

Reason : Whole of the inner charge will transfer to outer shell B.

- A. If both Assertion and Reason are true and Reason is the correct explanation of Assertion.
- B. If both Assertion and Reason are true but Reason is not correct explanation of Assertion.
- C. If Assertion is true but Reason is false.
- D. If Assertion is false but Reason is true.

**Answer: A**



[View Text Solution](#)

**13. Assertion :** When a dielectric is placed in an electric field, the electric field within the dielectric as well as the potential difference across the capacitor plates are reduced by a factor  $K$  (battery is not connected).

**Reason :** The dielectric constant is the ratio of the absolute permittivity of the dielectric to the permittivity of the free space.

- A. If both Assertion and Reason are true and Reason is the correct explanation of Assertion.
- B. If both Assertion and Reason are true but Reason is not correct explanation of Assertion.
- C. If Assertion is true but Reason is false.
- D. If Assertion is false but Reason is true.

**Answer: B**



[View Text Solution](#)

**14.** Assertion : No work is done in moving a charge along equatorial line.

Reason : The electric potential is everywhere zero on the equatorial line of a dipole.

- A. If both Assertion and Reason are true and Reason is the correct explanation of Assertion.
- B. If both Assertion and Reason are true but Reason is not correct explanation of Assertion.
- C. If Assertion is true but Reason is false.
- D. If Assertion is false but Reason is true.

**Answer: C**

 [Watch Video Solution](#)

**15. Assertion :** A and B are two conducting spheres of same radius.

A being solid and B hollow. Both are charged to the same potential.

Then, charge on A= charge on B.

Reason : Potentials on both are same.

A. If both Assertion and Reason are true and Reason is the correct explanation of Assertion.

B. If both Assertion and Reason are true but Reason is not correct explanation of Assertion.

C. If Assertion is true but Reason is false.

D. If Assertion is false but Reason is true.

**Answer: A**



[View Text Solution](#)

16. Assertion : Two concentric spherical shells A and B are charged by charges  $q_A$  and  $q_B$ . If  $q_A$  is negative, then  $V_A - V_B$  is also negative.



$$\text{Reason : } V_A - V_B = \left( \frac{q_A}{4\pi\epsilon_0} \right) \left( \frac{1}{R_A} - \frac{1}{r_B} \right)$$

therefore, if  $q_A$  is negative, then  $V_A - V_B$  is also negative.

- A. If both Assertion and Reason are true and Reason is the correct explanation of Assertion.
- B. If both Assertion and Reason are true but Reason is not correct explanation of Assertion.
- C. If Assertion is true but Reason is false.
- D. If Assertion is false but Reason is true.

**Answer: A**



**View Text Solution**

17. Two charge  $+q$  and  $-q$  are placed at distance  $r$ . Match the following two columns when distance between them is changed to  $r'$ .



[View Text Solution](#)

18. A capacitor is connected with battery. With battery remains connected some charges are done in capacitor/battery, which are given in Column I. corresponding to it match the two columns.



[View Text Solution](#)



19. A parallel plate capacitor is charged by a battery which is then disconnected. A dielectric slab is then inserted to fill the space between the plates. Match the changes that could occur with Column II.



 [View Text Solution](#)

20. The area of parallel plates of an air-filled capacitor is  $0.20m^2$  and the distance between them is  $0.01m$ . The potential difference across the plates is 3000 V. when a 0.01 m thick dielectric sheet is introduced between the plates, then the potential difference decreases to 1000 V. Now, match the two columns (all in SI units).



 [View Text Solution](#)

## (C) Chapter exercises

1. A capacitor of  $2\mu F$  is charged as shown in the figure. When the switch S is turned to position 2, the percentage of its stored energy dissipated is



- A. 20 %
- B. 75 %
- C. 80 %
- D. 0 %

**Answer: C**



[View Text Solution](#)

2. A parallel plate capacitor of area  $A$ , plate separation  $d$  and capacitance  $C$  is filled with four dielectric materials having dielectric constants  $K_1, K_2, K_3$  and  $K_4$  as shown in the figure below. If a single dielectric material is to be used to have the same capacitance  $c$  in this capacitor, then its dielectric constant  $K$  is given by



A.  $K = K_1 + K_2 + K_3 + 3K_4$

B.  $K = \frac{2}{3}(K_1 + K_2 + K_3) + 2K_4$

C.  $\frac{2}{K} = \frac{3}{K_1 + K_2 + K_3} + \frac{1}{K_4}$

D.  $\frac{1}{K} = \frac{1}{K_1} + \frac{1}{K_2} + \frac{1}{K_3} + \frac{3}{2K_4}$

**Answer: C**



**View Text Solution**

3. A parallel plate air capacitor of capacitance  $C$  is connected to a cell of  $emFV$  and then disconnected from it. A dielectric slab of dielectric constant  $K$ , which can just fill the air gap of the capacitor, is now inserted in it. Which of the following is incorrect ?

- A. The potential difference between the plates decreases  $K$  times
- B. The energy stored in the capacitor decreases  $K$  times
- C. The charge in energy stored is  $\frac{1}{2}CV^2\left(\frac{1}{K} - 1\right)$
- D. The charge on the capacitor is not conserved

**Answer: D**

 [Watch Video Solution](#)

4. Calculate the charge on equivalent capacitance of the combination shown in figure between the points P and N.



A.  $450\mu C$

B.  $225\mu C$

C.  $350\mu C$

D.  $900\mu C$

**Answer: A**



[View Text Solution](#)

5. An isolated sphere has a capacitance of 50 pF. (a) Calculate its radius. (b) how much charge should be placed on it to raise its potential to  $10^4 V$ ?

A. 90 cm

B. 45 cm

C. 11.50 cm

D. 5.75 cm

**Answer: B**



**Watch Video Solution**

6. A parallel plate capacitor has 91 plates, all are identical and arranged with same spacing between them. If the capacitance between adjacent plates is 3 pF. What will be the resultant capacitance?

A. 273 pF

B. 30 pF

C. 94 pF

D. 270 pF

**Answer: D**

 [Watch Video Solution](#)

7. A particle of mass  $1.96 \times 10^{-15}$  kg is kept in equilibrium between two horizontal metal plates having potential difference of 400 V separated apart by 0.02 m. then the charge on the particle is ( $e$ = electronic charge)

A.  $3e$

B.  $6e$

C.  $2e$

D.  $5e$

**Answer: B**

 [Watch Video Solution](#)

8. The distance of the closest approach of an alpha particle fired at a nucleus with kinetic energy  $K$  is  $r_0$ . The distance of the closest approach when the  $\alpha$  particle is fired at the same nucleus with kinetic energy  $2K$  will be



A.  $4r_0$

B.  $\frac{r_0}{2}$

C.  $\frac{r_0}{4}$

D.  $2r_0$

**Answer: B**



[View Text Solution](#)



9. A uniform electric field  $E$  is created between two parallel charged plates as shown in figure . An electron enters the field symmetrically between the plates with a speed  $v_0$ . The length of each plate is  $l$ . Find the angle of deviation of the path of the electron as it comes out of the field.

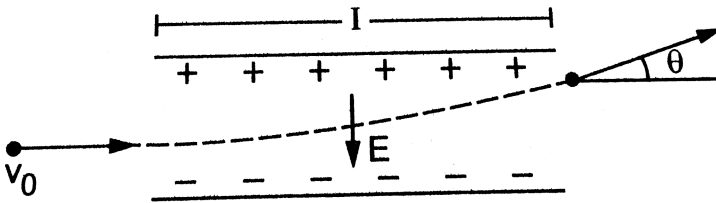

- A.  $\theta = \tan^{-1} \frac{El}{mv_0^2}$
- B.  $\theta = \tan^{-1} \left( \frac{eEl}{mv_0^2} \right)$
- C.  $\theta = \tan^{-1} \left( \frac{eEl}{mv_0} \right)$
- D.  $\theta = \tan^{-1} \left( \frac{eE}{mv_0^2} \right)$

Answer: B

 Watch Video Solution

10. A battery charges a parallel plate capacitor of thickness ( $d$ ) so that an energy [ $U_0$ ] is stored in the system. A slab of dielectric constant ( $K$ ) and thickness ( $d$ ) is then introduced between the plates of the capacitor. The new energy of the system is given by

A.  $KU_0$

B.  $K^2U_0$

C.  $\frac{U_0}{K}$

D.  $\frac{U_0}{K^2}$

**Answer: A**



**Watch Video Solution**

11. A capacitor of capacitance  $100(\mu)F$  is charged by connecting it to a battery of emf 12 V and internal resistance  $2(\Omega)$ . (a) Find the time constant of the circuit. (b) Find the time taken before 99% of maximum charge is stored on the capacitor.

- A. 0.92 ms
- B. 0.72 ms
- C. 0.34 ms
- D. 0.54 ms

**Answer: A**

 [Watch Video Solution](#)

12. An infinite number of identical capacitors each of capacitance  $1mF$  are connected as shown in the figure. Then the equivalent

capacitance between  $A$  and  $B$  is.

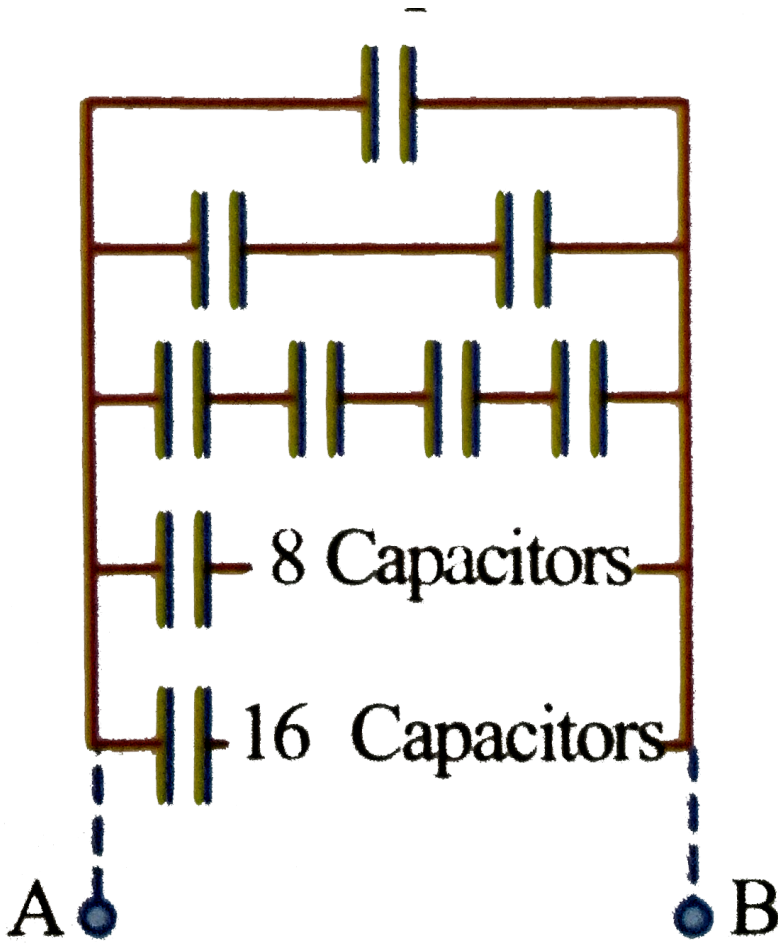

- A.  $1\mu F$
- B.  $2\mu F$
- C.  $\frac{1}{2}\mu F$
- D.  $\infty$

**Answer: B**

 [Watch Video Solution](#)

13. A parallel plate capacitor is charged and then isolated. The effect of increasing the plate separation on charge, potential and capacitance respectively are

- A. constant, decreases, increases
- B. constant, decreases, decreases
- C. constant, increases, decreases
- D. increases, decreases, decreases

**Answer: C**

 [Watch Video Solution](#)

14. A spherical shell of radius 10 cm is carrying a charge  $q$ . If the electric potential at distances 5 cm, 10 cm and 15 cm from the centre of the spherical shell is  $V_1$ ,  $V_2$  and  $V_3$  respectively, then

A.  $V_1 = V_2 > V_3$

B.  $V_1 > V_2 > V_3$

C.  $V_1 = V_2 < V_3$

D.  $V_1 < V_2 < V_3$

**Answer: A**

 [Watch Video Solution](#)

15. An electron of mass  $m_e$  initially at rest moves through a certain distance in a uniform electric field in time  $t_1$ . A proton of mass  $m_p$  also initially at rest takes time  $t_2$  to move through an equal

distance in this uniform electric field. Neglecting the effect of gravity, the ratio of  $t_2/t_1$  is nearly equal to

A. 1

B.  $\sqrt{\frac{M_p}{M_e}}$

C.  $\sqrt{\frac{M_e}{M_p}}$

D.  $\frac{M_e}{M_p}$

**Answer: B**



**Watch Video Solution**

**16.** Consider the diagram,



A parallel plate capacitor has the plate width  $t$  and length  $L$  while the separation between the plates is  $d$ . The capacitor is connected to a battery of voltage rating  $V$ . A dielectric which carefully occupy,

the space between the plates of the capacitor is slowly inserted between the plates. when length  $x$  of the dielectric slab is introduced into the capacitor, then energy stored in the system is

A.  $\frac{\epsilon_0 t V^2}{2d} L$

B.  $\frac{\epsilon_0 t V^2}{2d} L[x + 1]$

C.  $\frac{\epsilon_0 t V^2}{2d} [L + x(K - 1)]$

D.  $\frac{\epsilon_0^2 t^2 V^2}{2d^2} [L^2 + x + 1]$

**Answer: C**



[View Text Solution](#)

17. A conducting sphere of radius  $R$  is given a charge  $Q$ . The electric potential and the electric field at the centre of the sphere respectively are

A. zero and  $\frac{Q}{4\pi\epsilon_0 R^2}$



B.  $\frac{Q}{4\pi\epsilon_0 R}$  and zero

C.  $\frac{Q}{4\pi\epsilon_0 R}$  and  $\frac{Q}{4\pi\epsilon_0 R^2}$

D. Both are zero

**Answer: B**



**Watch Video Solution**

**18.** Two concentric spheres kept in air have radii  $R$  and  $r$ . They have similar charge and equal surface charge density  $\sigma$ . The electrical potential at their common centre is (where,  $\epsilon_0 =$  permittivity of free space)

A.  $\frac{\sigma(R + r)}{\epsilon_0}$

B.  $\frac{\sigma(R - r)}{\epsilon_0}$

C.  $\frac{\sigma(R + r)}{2\epsilon_0}$

D.  $\frac{\sigma(R + r)}{4\epsilon_0}$

**Answer: A**

 [Watch Video Solution](#)

**19.** Two charges of equal magnitude  $q$  are placed in air at a distance  $2a$  apart and third charge  $-2q$  is placed at mid-point . The potential energy of the system is ( $\epsilon_0$  = permittivity of free space)

A.  $-\frac{q^2}{8\pi\epsilon_0 a}$

B.  $-\frac{3q^2}{8\pi\epsilon_0 a}$

C.  $-\frac{5q^2}{8\pi\epsilon_0 a}$

D.  $-\frac{7q^2}{8\pi\epsilon_0 a}$

**Answer: D**

 [Watch Video Solution](#)

20. Consider two concentric spherical metal shells of radii  $r_1$  and  $r_2$  ( $r_2 > r_1$ ). If the outer shell has a charge  $q$  and the inner one is grounded, then the charge on the inner shell is

A.  $\frac{-r_2}{r_1}q$

B. zero

C.  $\frac{-r_1}{r_2}q$

D.  $-q$

Answer: C



Watch Video Solution

21. What is the electric potential at a distance of 9 cm from 3 nC?

A. 270 V

B. 3 V

C. 300 V

D. 30 V

**Answer: C**



**Watch Video Solution**

22. A hollow sphere of radius 0.1 m has a charge of  $5 \times 10^{-8} C$ . The potential at a distance of 5 cm from the centre of the sphere is

$$\left( \frac{1}{4\pi\epsilon_0} = 9 \times 10^9 Nm^2C^{-2} \right)$$

A. 4000 V

B. 4500 V

C. 5000 V

D. 6000 V

**Answer: B**



Watch Video Solution

23. Three capacitors  $3\mu F$ ,  $6\mu F$  and  $6\mu F$  are connected in series to source of 120 V. The potential difference in volt, across the  $3\mu F$  capacitor will be

A. 24 V

B. 30 V

C. 40 V

D. 60 V

**Answer: D**



Watch Video Solution

24. The capacitance of two concentric spherical shells of radii  $R_1$  and  $R_2$  ( $R_2 > R_1$ ) is

A.  $4\pi\epsilon_0 R_2$

B.  $4\pi\epsilon_0 \frac{(R_2 - R_1)}{R_1 R_2}$

C.  $4\pi\epsilon_0 \frac{R_1 R_2}{(R_2 - R_1)}$

D.  $4\pi\epsilon_0 R^1$

**Answer: C**



**Watch Video Solution**

25. Two capacitors of  $10\mu F$  and  $20\mu F$  are connected to 200 V and 100 V sources, respectively. If they are connected by the wire, then what is the common potential of the capacitors?

A. 133.3 V

B. 150 V

C. 300 V

D. 400 V

Answer: A

 Watch Video Solution

26. In the given figure the capacitors  $C_1, C_3, C_4, C_5$  have a capacitance  $4\mu F$  each if the capacitor  $C_2$  has a capacitance  $10\mu F$ , then effective capacitance between  $A$  and  $B$  will be

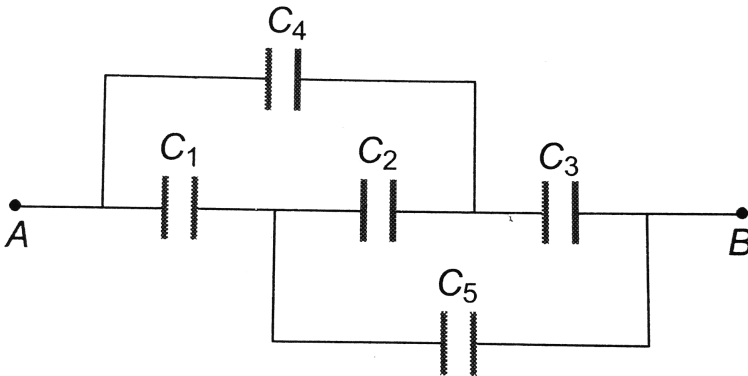

A.  $2\mu F$

B.  $4\mu$

C.  $6\mu F$

D.  $8\mu F$

Answer: B

 Watch Video Solution

27.  $A$ ,  $B$  and  $C$  are three points in a uniform electric field. The electric potential is

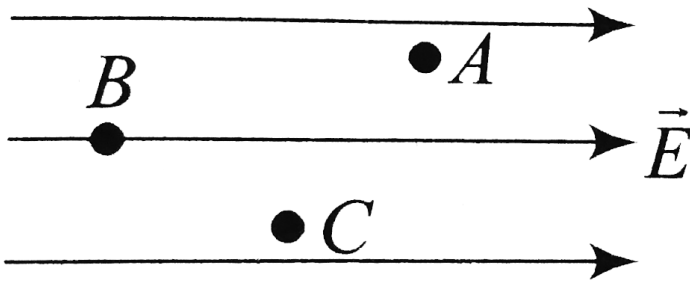



- A. maximum at A
- B. maximum at B
- C. maximum at C
- D. same at all the three points A, B and C

**Answer: B**

 [Watch Video Solution](#)

**28.** Two thin dielectric slabs of dielectric constants  $K_1$  and  $K_2$  ( $K_1 < K_2$ ) are inserted between plates of a parallel plate capacitor, as shown in the figure. The variation of electric field  $E$  between the plates with distance  $d$  as measured from plate  $P$  is

correctly shown by

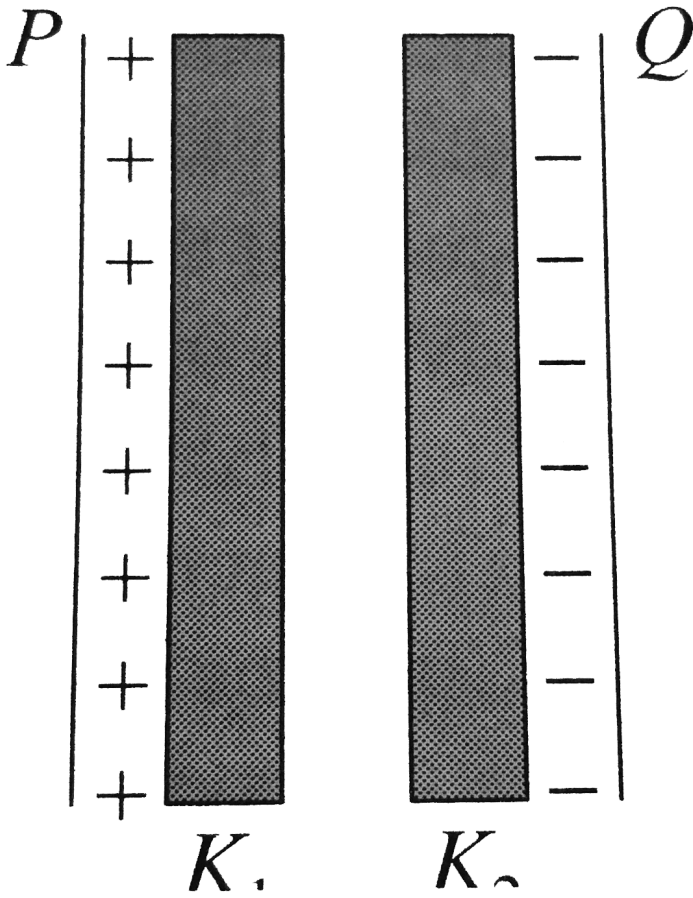

A. 

B. 

C. 

D. 

**Answer: B**



**Watch Video Solution**

**29.** Two identical capacitors are first connected in series and then in parallel. The ratio of equivalent capacitance is

A. 1 : 1

B. 1 : 2

C. 1 : 3

D. 1 : 4

**Answer: D**



**Watch Video Solution**

**30.** Two capacitors having capacitances  $C_1$  and  $C_2$  are charged with 120 V and 200 V batteries respectively. When they are connected in parallel now, it is found that the potential on each one of them is zero. Then,

A.  $5C_1 = 3C_2$

B.  $8C_1 = 5C_2$

C.  $9C_1 = 5C_2$

D.  $3C_1 = 5C_2$

**Answer: D**

 [Watch Video Solution](#)

**31.** A small oil drop of mass  $10^{-6}$  kg is hanging in at rest between two plates separated by 1 mm having in at rest between two plates

separated by 1 mm having a potential difference of 500 V. The charge on the drop is ( $g = 10ms^{-2}$ )

A.  $2 \times 10^{-9}C$

B.  $2 \times 10^{-11}C$

C.  $2 \times 10^{-6}C$

D.  $2 \times 10^{-9}C$

**Answer: D**



**Watch Video Solution**

**32.** Two metal spheres of radii 0.01 m and 0.02 m are given a charge of 15 mC and 45 mC, respectively. They are then connected by a wire. The final charge on the first is  $\dots \times 10^{-3}C$ .

A. 40

B. 30

C. 20

D. 10

**Answer: C**



**Watch Video Solution**

**33.** Two concentric spheres of radii  $R$  and  $r$  have similar charges with equal surface charge densities (*sigam*). The electric potential at their common centre is

A.  $\frac{\sigma}{\epsilon_0}(R + r)$

B.  $\frac{\sigma}{\epsilon_0}(R - r)$

C.  $\frac{\sigma}{\epsilon_0} \left( \frac{1}{R} + \frac{1}{r} \right)$

D.  $\frac{\sigma}{\epsilon_0} \left( \frac{1}{R} \right)$

**Answer: A**

 [Watch Video Solution](#)

34. See the diagram, area of each plate is  $2.0m^2$  and  $d = 2 \times 10^{-3}m$ . A charge of  $8.85 \times 10^{-8}C$  is given to Q. Then, the potential of Q becomes



- A.  $13V$
- B.  $10V$
- C.  $6.67V$
- D.  $8825V$

**Answer: C**

 [View Text Solution](#)

35. A soap bubble is charged to a potential 12 V. If its radius is doubled, then the potential of the bubble becomes

A. 12 V

B. 24 V

C. 3 V

D. 6 V

**Answer: D**



[Watch Video Solution](#)

36. A sphere of  $4\text{cm}$  radius is suspended within a hollow sphere of  $6\text{cm}$  radius. The inner sphere is charged to potential 3 e.s.u. and the outer sphere is earthed. The charge on the inner sphere is

A.  $\frac{1}{4}$  esu



B. 30 esu

C. 36 esu

D. 54 esu

**Answer: C**



**Watch Video Solution**

**37.** In the adjoining figure, the potential difference across the  $4.5\mu F$  capacitor is



A. 4 V

B. 6 V

C. 8 V

D. 4.5 V

Answer: C

 [View Text Solution](#)

38. The equivalent capacity between points A and B in figure will be, while capacitance of each capacitor is  $3\mu F$ .



A.  $2\mu F$

B.  $4\mu F$

C.  $7\mu F$

D.  $9\mu F$

Answer: D

 [View Text Solution](#)

39. In the arrangement of capacitors shown in figure, each capacitor is of  $9\mu F$ , then the equivalent capacitance between the points a and B is



- A.  $9\mu F$
- B.  $18\mu F$
- C.  $4.5\mu F$
- D.  $15\mu F$

**Answer: D**



[View Text Solution](#)

40. The equivalent capacitance between points A and B will be



- A.  $10\mu F$

B.  $15\mu F$

C.  $10.8\mu F$

D.  $69\mu F$

**Answer: A**



**View Text Solution**

**41.** Four metallic plates each with a surface area of one side  $A$  are placed at a distance  $d$  from each other as shown. Then, the capacitance of the system between X and Y is



A.  $\frac{2\varepsilon_0 A}{d}$

B.  $\frac{2\varepsilon_0 A}{3d}$

C.  $\frac{3\varepsilon_0 A}{d}$

D.  $\frac{3\varepsilon_0 A}{2d}$

Answer: D



[View Text Solution](#)

42. Four capacitors each of capacity  $8\mu F$  are connected with each other as shown in figure. The equivalent capacitance between points X and Y will be



- A.  $2\mu F$
- B.  $8\mu F$
- C.  $16\mu F$
- D.  $32\mu F$

Answer: D



[View Text Solution](#)

43. Four point charges  $-Q$ ,  $-q$ ,  $2q$  and  $2Q$  are placed, one at each corner of the square. The relation between  $Q$  and  $q$  for which the potential at the centre of the square is zero is

A.  $Q = -q$

B.  $Q = -\frac{1}{q}$

C.  $Q = q$

D.  $Q = \frac{1}{q}$

**Answer: A**



**Watch Video Solution**

44. A spherical drop of capacitance  $1\mu F$  is broken into eight drop of equal radius. Then, the capacitance of each small drop is

A.  $\frac{1}{2}\mu F$

B.  $\frac{1}{4}\mu F$

C.  $\frac{1}{8}\mu F$

D.  $8\mu F$

**Answer: A**



**Watch Video Solution**

45. A capacitor having capacity of  $2\mu F$  is charged to  $200V$  and then the plates of the capacitor are connected to a resistance wire. The heat produced in joule will be

A.  $2 \times 10^{-2}$

B.  $4 \times 10^{-2}$

C.  $4 \times 10^4$

D.  $4 \times 10^{10}$

**Answer: B**



**Watch Video Solution**

**46.** The potential of a large liquid drop when eight liquid drops are combined is 20 V. Then, the potential of each single drop was

A. 10 V

B. 7.5 V

C. 5 V

D. 2.5 V

**Answer: A**



**Watch Video Solution**



47. The electric field in a certain region is given by  $E = 5\hat{i} - 3\hat{j} \text{ kV/m}$ . The potential difference  $V_B - V_A$  between points a and B having coordinates (4, 0, 3) m and (10, 3, 0) m respectively, is equal to

- A. 21 kV
- B.  $-21 \text{ kV}$
- C.  $39 \text{ kV}$
- D.  $-39 \text{ kV}$

**Answer: C**

 [Watch Video Solution](#)

48. In a parallel plate capacitor with plate area A and charge Q, the force on one plate because of the charge on the other is equal to

A.  $\frac{Q^2}{\epsilon_0 A^2}$

B.  $\frac{Q^2}{2\epsilon_0 A^2}$

C.  $\frac{Q^2}{\epsilon_0 A}$

D.  $\frac{Q^2}{2\epsilon_0 A}$

**Answer: D**

 [Watch Video Solution](#)

**49.** Two capacitors,  $3\mu F$  and  $4\mu F$ , are individually charged across a 6V battery. After being disconnected from the battery, they are connected together with the negative plate of one attached to the positive plate of the other. What is the common potential?

A.  $1.26 \times 10^{-4} J$

B.  $2.57 \times 10^{-4} J$

C.  $1.26 \times 10^{-6} J$

D.  $2.57 \times 10^{-6} J$

**Answer: A**

 [Watch Video Solution](#)

50. The equivalent capacitance between A and B for the combination of capacitors shown in figure, where all capacitances are in microfarad is



A.  $6.0\mu F$

B.  $4.0\mu F$

C.  $2.0\mu F$

D.  $3.0\mu F$

**Answer: A**



[View Text Solution](#)