



## PHYSICS

# BOOKS - NCERT FINGERTIPS PHYSICS (HINGLISH)

## ELECTROMAGNETIC WAVES

### Displacement Current

1. Maxwell in his famous equations of electromagnetism introduced the concept of

A. ac current

B. displacement current

C. impedance

D. reactance

**Answer: B**



**Watch Video Solution**

2. Displacement current goes through the gap between the plates of a capacitor when the charge of the capacitor

A. is changing with time

B. decreases

C. does not change

D. decreases to zero

**Answer: A**



**Watch Video Solution**

3. The charge on a parallel plate capacitor varies as  $q = q_0 \cos 2\pi t$ . The plates are very large and close together (area =  $A$ , separation =  $d$ ). The displacement current through the capacitor is

A.  $q_0 2\pi \nu \sin \pi \nu t$

B.  $-q_0 2\pi \nu \sin 2\pi \nu t$

C.  $q_0 2\pi \sin \pi vt$

D.  $q_0 \pi v \sin 2\pi vt$

**Answer: B**



**Watch Video Solution**

4. A parallel- plate capacitor with plate area  $A$  and separation between the plates  $d$ , is charged by a constant current  $i$ . Consider a plane surface of area  $A/2$  parallel to the plates and drawn symmetrically between the plates. Find the displacement current through this area.

A.  $I$

B.  $\frac{I}{2}$

C.  $\frac{I}{4}$

D.  $\frac{I}{8}$

**Answer: B**



[Watch Video Solution](#)

5. In order to establish an instantaneous displacement current of  $1mA$  in the space between the plates of  $2\mu F$  parallel plate capacitor, the potential difference need to apply is

A.  $100V s^{-1}$

B.  $200V s^{-1}$

C.  $300V s^{-1}$

D.  $500V s^{-1}$

**Answer: D**



**Watch Video Solution**

**6.** The conduction current is the same as displacement current when the source is

A. ac only

B. dc only

C. either ac or dc

D. neither dc nor ac

**Answer: C**

 [Watch Video Solution](#)

7. A capacitor made of two circular plates each of radius 12 cm and separated by 5 mm. The capacitor is being charged by an external source. The charging current is constant and equal to 0.15 A. The capacitance of the parallel plate capacitor is

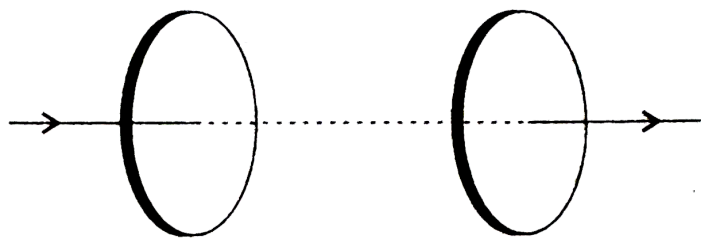

A. 40 pF

B. 45 pF

C. 70 pF

D. 80 pF

**Answer: D**



**Watch Video Solution**

**8.** In the question number 7, the rate of change of potential difference between the plates is

A.  $2.41 \times 10^9 \text{ V s}^{-1}$

B.  $1.87 \times 10^9 \text{ V s}^{-1}$



C.  $3.2 \times 10^{-4} V_s^{-1}$

D.  $4.5 \times 10^{-4} V_s^{-1}$

**Answer: B**



**View Text Solution**

9. If a variable frequency ac source is connected to a capacitor then with decrease in frequency the displacement current will

A. increase

B. decrease

C. remains constant

D. first decrease then increase

**Answer: B**



**Watch Video Solution**

10. Which among the following does not represent Maxwell's equation?

A.  $\oint \vec{E} \cdot d\vec{A} = \frac{q}{\epsilon_0}$

B.  $\oint \vec{B} \cdot d\vec{A} = 0$

C.  $\oint \vec{E} \cdot d\vec{l} = \frac{-dB}{dt}$

D.  $\oint \vec{B} \cdot d\vec{l} = \mu_0 I_C + \mu_0 \epsilon_0 \frac{d\phi_E}{dt}$

**Answer: C**



**Watch Video Solution**

## Electromagnetic Waves

1. An electromagnetic wave can be produced, when charge is

A. moving with a constant velocity

B. moving in a circular orbit

C. falling in an electric field

D. both (b) and (c)

**Answer: D**



**Watch Video Solution**

2. If  $\mu_0$  be the permeability and  $\epsilon_0$  be the permittivity of a medium, then its refractive index is given by

A.  $\frac{1}{\sqrt{\mu_0 \epsilon_0}}$

B.  $\frac{1}{\mu_0 \epsilon_0}$

C.  $\sqrt{\mu_0 \epsilon_0}$

D.  $\mu_0 \epsilon_0$

**Answer: C**



**Watch Video Solution**

3. Electromagnetic wave consists of periodically oscillating electric and magnetic vectors

A. in mutually perpendicular planes but vibrating with a phase difference of  $\pi$

B. in mutually perpendicular planes but vibrating with a phase difference of  $\frac{\pi}{2}$

C. in randomly oriented planes but vibrating in phase

D. in mutually perpendicular planes but vibrating in phase

**Answer: D**



**Watch Video Solution**

4. A plane electromagnetic wave travels in vacuum along z-direction. If the frequency of the wave is 40 MHz then its wavelength is

A. 5 m

B. 7.5 m

C. 8.5 m

D. 10 m

**Answer: B**



Watch Video Solution

5. The electric field associated with an electromagnetic wave in vacuum is given by

$$\vec{E} = 40 \cos(kz - 6 \times 10^8 t) \hat{i},$$

where  $E$ ,  $z$  and  $t$  are in volt per meter, meter and second respectively. The value of wave vector  $k$  is

A.  $2 \text{ m}^{-1}$

B.  $0.5 \text{ m}^{-1}$

C.  $6 \text{ m}^{-1}$

D.  $3 \text{ m}^{-1}$

**Answer: A**



[Watch Video Solution](#)

6. A radio can tune to any station in 7.5 MHz to 12MHz band. The corresponding wavelength band is

A. 40 M to 25 m

B. 30 m to 25 m

C. 25 m to 10 m

D. 10 m to 5 m

**Answer: A**



[Watch Video Solution](#)



7. Which of the following statement is false for the properties of electromagnetic waves?

A. Both electric and magnetic field vectors attain the maxima and minima at the same place and same time.

B. The energy in electromagnetic wave is divided equally between electric and magnetic field vectors.

C. Both electric and magnetic field vectors are parallel to each other and perpendicular to the direction of propagation of wave

D. These waves do not require any material medium for propagation.

**Answer: C**



**Watch Video Solution**

**8.** Which of the following has/have zero average value in a plane electromagnetic wave?

A. Both magnetic and electric fields

B. Electric field only

C. Magnetic field only

D. None of these

**Answer: A**



**Watch Video Solution**

9. A plane electromagnetic wave propagating along x-direction can have the following pairs of  $E$  and  $B$ .

A.  $E_y, B_z$

B.  $E_z, B_y$

C.  $E_x, B_y$

D. both (a) and (b)

**Answer: D**



**Watch Video Solution**

10. A charged particle oscillates about its mean equilibrium position with a frequency of  $10^9$  Hz. The frequency of electromagnetic waves produced by the oscillator is

A.  $10^6 Hz$

B.  $10^7 Hz$

C.  $10^8 Hz$

D.  $10^9 Hz$

**Answer: D**



**Watch Video Solution**

11. In the question number 20, the electromagnetic waves

- A. will have same frequency
- B. will have a wavelength of 0.3 m
- C. fall in the region of radiowaves
- D. all of these

**Answer: D**



**Watch Video Solution**

12. The refractive index and the permeability of a medium are respectively 1.5 and  $5 \times 10^{-7} \text{Hm}^{-1}$ . The relative permittivity of the medium is nearly

A. 25

B. 15

C. 10

D. 6

**Answer: D**



**Watch Video Solution**

13. An electromagnetic wave of frequency  $\nu = 3.0\text{MHz}$  passes from vacuum into a dielectric medium with permittivity  $\epsilon = 4.0$ . Then

A. wavelength and frequency both become half.

B. wavelength is doubled and frequency remains unchanged.

C. wavelength and frequency both remain unchanged.

D. wavelength is halved and frequency remains unchanged.

**Answer: D**

 Watch Video Solution

14. If  $E$  and  $B$  denote electric and magnetic fields respectively, which of the following is dimensionless?

A.  $\sqrt{\mu_0 \epsilon_0} \frac{E}{B}$

B.  $\mu_0 \epsilon_0 \frac{E}{B}$

C.  $\mu_0 \epsilon_0 \left( \frac{B}{E} \right)^2$

D.  $\frac{E}{\epsilon_0} \frac{\mu_0}{B}$

**Answer: A**

 Watch Video Solution



15. The amplitude of em wave in vacuum is doubled with no other changes made to wave. As a result of this doubling of the amplitude, which of the following statement is correct.

- A. The speed of wave propagation changes only
- B. The frequency of the wave change only
- C. The wavelength of the wave changes only
- D. None of these

**Answer: D**



**Watch Video Solution**

16. An electromagnetic wave propagating along north has its electric field vector upwards. Its magnetic field vector point towards

A. north

B. east

C. west

D. downwards

**Answer: B**



**Watch Video Solution**

17. Which one of the following is the property of a monochromatic, plane electromagnetic wave in free space?

A. Electric and magnetic fields have a phase difference of  $\pi/2$

B. The energy contribution of both electric and magnetic fields are equal

C. The direction of propagation is in the direction of  $\vec{B} \times \vec{E}$

D. The pressure exerted by the wave is the product of its speed energy density

**Answer: B**



**Watch Video Solution**

**18.** The ratio of amplitude of magnetic field to the amplitude of electric field for an electromagnetic wave propagating in vacuum is equal to

- A. the speed of light in vacuum
- B. reciprocal of speed of light in vacuum
- C. the ratio of magnetic permeability to the electric susceptibility of vacuum
- D. unity

**Answer: B**



**Watch Video Solution**

**19.** A plane electromagnetic wave travels in free space along X-direction. If the value of  $\vec{B}$  (in tesla) at a particular point in space and time is  $1.2 \times 10^{-8} \hat{k}$ . The value of  $\vec{E}$  (in  $Vm^{-1}$ ) at that point is

A.  $1.2\hat{j}$

B.  $3.6\hat{k}$

C.  $1.2\hat{k}$

D.  $3.6\hat{j}$

**Answer: D**



**Watch Video Solution**

**20.** A plane electromagnetic wave of frequency  $25\text{MHz}$  travels in free space along the  $x$ -direction. At a particular point in space and time,  $E = (6.3j)\text{V}/\text{m}$ .

What is  $B$  at this point?

A.  $1.2 \times 10^{-6}\text{T}$

B.  $1.2 \times 10^{-8}\text{T}$

C.  $2.1 \times 10^{-6}\text{T}$

D.  $2.1 \times 10^{-8}\text{T}$

Answer: D



Watch Video Solution

21. The amplitude of the magnetic field part of a harmonic electromagnetic wave in vacuum is  $B_0 = 510\text{nT}$ . What is the amplitude of the electric field part of the wave?

A.  $120\text{N C}^{-1}$

B.  $134\text{N C}^{-1}$

C.  $510\text{N C}^{-1}$

D.  $153\text{N C}^{-1}$

Answer: D



Watch Video Solution

22. A plane electromagnetic wave of frequency  $25\text{MHz}$  travels in free space along the  $x$ -direction. At a particular point in space and time,  $E = (6.3j)\text{V}/\text{m}$ .

What is  $B$  at this point?

A.  $8.33 \times 10^{-8} \hat{k}\text{T}$

B.  $18.9 \times 10^{-8} \hat{k}\text{T}$

C.  $4.1 \times 10^{-8} \hat{k}\text{T}$

D.  $2.1 \times 10^{-8} \hat{k}\text{T}$



**Answer: D**



**Watch Video Solution**

**23.** An electromagnetic wave is propagating along x-axis. At  $x = 1$  m and  $t = 10$  s, its electric vector  $\left| \vec{E} \right| = 6V/m$  then the magnitude of its magnetic vector is

A.  $2 \times 10^{-8}T$

B.  $3 \times 10^{-7}T$

C.  $6 \times 10^{-8}T$

D.  $5 \times 10^{-7}T$

**Answer: A**



**Watch Video Solution**

24. which of the following is not true for electromagnetic waves ?

A. They transport energy.

B. They have momentum.

C. They travel at different speeds in air depending on their frequency.

D. They travel at different speeds in medium depending on their frequency.

**Answer: C**



**Watch Video Solution**

25. The photon energy in units of eV for electromagnetic waves of wavelength 2 cm is

A.  $2.5 \times 10^{-19}$

B.  $5.2 \times 10^{16}$

C.  $3.2 \times 10^{-16}$

D.  $6.2 \times 10^{-5}$

**Answer: D**



**Watch Video Solution**

26. The electric field of an electromagnetic wave travelling through vacuum is given by the equation  $E = E_0 \sin(kx - \omega t)$ . The quantity that is independent of wavelength is

- A.  $k\omega$
- B.  $\frac{k}{\omega}$
- C.  $k^2\omega$
- D.  $\omega$

**Answer: B**



**Watch Video Solution**

27. The frequency of *e. m* wave which is best suit to observe a particle of radius  $3 \times 10^{-4}$  is of order of:

A.  $10^{15} Hz$

B.  $10^{14} Hz$

C.  $10^{13} Hz$

D.  $10^{12} Hz$

**Answer: A**



**Watch Video Solution**

**28.** The electric field part of an electromagnetic wave in vacuum is

$$E = 3.1 \frac{N}{C} \cos \left[ \left( 1.8 \frac{\text{rad}}{\text{m}} \right) y + \left( 5.4 \times 10^8 \frac{\text{rad}}{\text{s}} \right) t \right] \hat{i}$$

The wavelength of this part of electromagnetic wave is

A. 1.5 m

B. 2 m

C. 2.5 m

D. 3.5 m

**Answer: D**



**Watch Video Solution**

29. In the question number 38, the frequency corresponding to the given part of electromagnetic wave is

A.  $5.4 \times 10^8 \text{ Hz}$

B.  $8.6 \times 10^7 \text{ Hz}$

C.  $3.2 \times 10^8 \text{ Hz}$

D.  $4.8 \times 10^7 \text{ Hz}$ .

**Answer: B**



**Watch Video Solution**

30. In the question 38, the amplitude of magnetic field part of the given wave is

A.  $2 \times 10^{-8}T$

B.  $1.03 \times 10^{-8}T$

C.  $4.22 \times 10^{-8}T$

D.  $5 \times 10^{-8}T$

**Answer: B**



**Watch Video Solution**



31. The electric field part of an electromagnetic wave in a medium is represented by

$$E_x = 0,$$

$$E_y = 2.5 \frac{N}{C} \cos \left[ \left( 2\pi \times 10^6 \frac{rad}{m} \right) t - \left( \pi \times 10^{-2} \frac{rad}{s} \right) x \right]$$

$$E_z = 0.$$

The wave is

A. moving along  $x$  direction with frequency  $10^6$  Hz

and wavelength 100m

B. moving along  $x$  direction with frequency  $10^6$  Hz

and wavelength 200 m

C. moving along  $-x$  direction with frequency  $10^6$  Hz

and wavelength 200 m

D. moving along  $y$  direction with frequency

$2\pi \times 10^6$  Hz and wavelength 200 m

**Answer: B**



**Watch Video Solution**

**32.** An electromagnetic wave of intensity  $I$  falls on a surface kept in vacuum and exerts radiation pressure  $p$  on it. Which of the following are true ?

A. Radiation pressure is  $I/c$  if the wave is totally absorbed.

B. Radiation pressure is  $I/c$  if the wave is totally reflected.

C. Radiation pressure is  $2 I/c$  if the wave is totally reflected.

D. Radiation pressure is in the range  $I/c < p < 2I/c$  for real surfaces.

**Answer: B**



**Watch Video Solution**

33. A plane electromagnetic wave is incident on a material surface. The wave delivers momentum  $p$  and

energy  $E$ .

A.  $p \neq 0, E \neq 0$

B.  $p = 0, E = 0$

C.  $p = 0, E \neq 0$

D.  $p \neq 0, E = 0$

**Answer: A**



**Watch Video Solution**

**34.** Radiations of intensity  $0.5W/m^2$  are striking a metal plate. The pressure on the plate is

A.  $0.166 \times 10^{-8} N m^{-2}$

B.  $0.332 \times 10^{-8} \text{N m}^{-2}$

C.  $0.111 \times 10^{-8} \text{N m}^{-2}$

D.  $0.083 \times 10^{-8} \text{N m}^{-2}$

**Answer: A**



**Watch Video Solution**

**35.** Light with an energy flux of  $18 \text{W} / \text{cm}^2$  falls on a non-reflecting surface at normal incidence. If the surface has an area of  $20 \text{cm}^2$ , find the average force exerted on the surface during a 30 minute time span.

A.  $2.1 \times 10^{-6} \text{N}$

B.  $1.2 \times 10^{-6} N$

C.  $1.2 \times 10^6 N$

D.  $2.1 \times 10^6 N$

**Answer: B**



**Watch Video Solution**

**36.** The rms value of the electric field of the light from the sun is  $720 N/C$  The total energy density of the electromagnetic wave is

A.  $3.3 \times 10^{-3} J m^{-3}$

B.  $4.58 \times 10^{-6} J m^{-3}$

C.  $6.37 \times 10^{-9} \text{ J m}^{-3}$

D.  $81.35 \times 10^{-12} \text{ J m}^{-3}$ .

**Answer: B**



**Watch Video Solution**

**37.** The electric field of a plane electromagnetic wave varies with time of amplitude  $2 \text{ V m}^{-1}$  propagating along z-axis. The average energy density of the magnetic field is (in  $\text{J m}^{-3}$ )

A.  $13.29 \times 10^{-12}$

B.  $8.86 \times 10^{-12}$

C.  $17.72 \times 10^{-12}$

D.  $4.43 \times 10^{-12}$

**Answer: B**



**Watch Video Solution**

**38.** The magnetic field of a beam emerging from a filter facing a floodlight is given by

$$B = 12 \times 10^{-8} \sin(1.20 \times 10^7 z - 3.60 \times 10^{14} t) T.$$

What is the average intensity of the beam?

A.  $1.71 \text{ W m}^{-2}$

B.  $2.1 \text{ W m}^{-2}$



C.  $3.2\text{W m}^{-2}$

D.  $2.9\text{W m}^{-2}$

**Answer: A**



**Watch Video Solution**

**39.** Assume a bulb of efficiency  $2.5\%$  as a point source.

The peak values of electric and magnetic fields produced by the radiation coming from a  $100\text{ W}$  bulb at a distance of  $3\text{ m}$  is respectively

A.  $2.5\text{V m}^{-1}, 3.6 \times 10^{-8}\text{T}$

B.  $4.2\text{V m}^{-1}, 2.8 \times 10^{-8}\text{T}$

C.  $4.08\text{V m}^{-1}, 1.36 \times 10^{-8}\text{T}$

D.  $3.6\text{V m}^{-1}, 4.2 \times 10^{-8}\text{T}$

**Answer: C**



**Watch Video Solution**

**40.** About 6% of the power of a 100 W light bulb is converted to visible radiation. The average intensity of visible radiation at a distance of 8 m is (Assume that the radiation is emitted isotropically and neglect reflection.)

A.  $3.5 \times 10^{-3}\text{W m}^{-2}$

B.  $5.1 \times 10^{-3} \text{W m}^{-2}$

C.  $7.2 \times 10^{-3} \text{W m}^{-2}$

D.  $2.3 \times 10^{-3} \text{W m}^{-2}$

**Answer: C**



**Watch Video Solution**

## Electromagnetic Spectrum

1. Which of the following is not an electromagnetic wave?

A. X-rays

B.  $\gamma$ -rays

C.  $\beta$ -rays

D. Heat rays

**Answer: C**



**Watch Video Solution**

2. We consider the radiation emitted by the human body which of the following statements is true?

A. The radiation emitted is in the infrared region.

B. The radiation is emitted only during the day.

C. The radiation is emitted during the summers and absorbed during winters.

D. The radiation emitted lies in the ultraviolet region and hence is not visible.

**Answer: A**



**Watch Video Solution**

3. Radio wave diffract around building although light waves do not. The reason is that radio waves

A. travel with speed larger than  $c$

B. have much larger wavelength than light

C. are not electromagnetic waves

D. None of these.

**Answer: B**



**Watch Video Solution**

4. The ultra high frequency band of radio waves in electromagnetic wave is used as in

A. television waves

B. cellular phone communication

C. commercial FM radio

D. both (a) and (c)

**Answer: B**



**Watch Video Solution**

5. The part of the spectrum of the electromagnetic radiation used to cook food is

A. ultraviolet rays

B. cosmic rays

C. X rays

D. microwaves

**Answer: D**



**Watch Video Solution**

6. The frequency  $1057\text{MHz}$  of radiation arising from two close energy levels in hydrogen belong to:

A. Infrared rays

B. X-rays

C.  $\gamma$ -rays

D. Radio waves

**Answer: D**



**Watch Video Solution**



7. A micro-wave and an ultrasonic sound wave have the same wavelength. Their frequencies are in the ratio (approximately)

A.  $10^2$

B.  $10^4$

C.  $10^6$

D.  $10^8$

**Answer: C**



**Watch Video Solution**

8. The waves used by artificial satellites for communication is

- A. microwaves
- B. infrared waves
- C. radio waves
- D. X-rays

**Answer: A**



**Watch Video Solution**

9. The produced rays in sonography are

A. Microwaves

B. Infrared rays

C. Radio waves

D. Ultrasonic waves

**Answer: D**



**Watch Video Solution**

**10.** Which of the following electromagnetic wave play an important role in maintaining the earth's warmth or average temperature through the greenhouse effect?

A. Visible rays

B. Infrared waves

C. Gamma rays

D. Ultraviolet rays

**Answer: B**



**Watch Video Solution**

**11.** Which of the following electromagnetic wave is used in high precision application like LASIK eye surgery?

A. Microwave

B. Ultraviolet rays

C. Gamma rays

D. X-rays

**Answer: B**



**Watch Video Solution**

**12.** The crystal structure can be studied by using

A. UV rays

B. X-rays

C. IR radiation

D. Microwaves

**Answer: B**



[Watch Video Solution](#)

**13.** An electromagnetic radiation has an energy of 13.2 keV. Then the radiation belongs to region of

A. visible light

B. ultraviolet

C. infrared

D. X-ray

**Answer: D**



[Watch Video Solution](#)

14. Which of the following electromagnetic waves has smaller wavelength ?

A. X-rays

B. Microwaves

C.  $\gamma$ -rays

D. Radiowaves.

**Answer: C**



**Watch Video Solution**

15. Which of the following electromagnetic waves is used in medicine of destroy cancer cells?

A. IR-rays

B. Visible rays

C. Gamma rays

D. Ultraviolet rays

**Answer: C**



**Watch Video Solution**



16. The decreasing order of wavelength of infrared, microwave, ultraviolet and gamma rays is

A. microwave, infrared, ultraviolet, gamma rays

B. infrared, microwave, ultraviolet, gamma rays

C. gamma rays, ultraviolet, infrared, microwaves

D. microwaves, gamma rays, infrared, ultraviolet

**Answer: A**



**Watch Video Solution**

17. A. Wavelength of microwaves is greater than that of ultraviolet rays.

B. The wavelength of infrared rays is lesser than that of ultraviolet rays.

C. The wavelength of microwaves is lesser than that of infrared rays

D. Gamma ray has shortest wavelength in the electromagnetic spectrum

Choose the correct option.

A. A and B are true

B. B and C are true

C. C and D are true

D. A and D are true

**Answer: D**



**Watch Video Solution**

**18.** X-rays and  $\gamma$ -rays of same energies are distinguished by their

- A. frequency
- B. charges
- C. ionising power
- D. method of production

**Answer: D**



**Watch Video Solution**

19. choose the correct option. If speed of gamma rays, X-rays and microwaves are  $V_g$ ,  $V_x$  and  $V_m$ .

A.  $v_g < v_X < v_m$

B.  $v_g > v_X > v_m$

C.  $v_g > v_X < v_m$

D.  $v_g = v_X = v_m$

**Answer: D**



**Watch Video Solution**

20. X-rays, gamma rays and microwaves travelling in vacuum have

- A. same wavelength but different velocities
- B. same frequency but different velocities
- C. same velocity but different wavelentghs
- D. same velocity and same frequency

**Answer: C**



**Watch Video Solution**

**Higher Order Thinking Skills**

1. Sea water at frequency  $\nu = 4 \times 10^8$  Hz has permittivity  $\epsilon \approx 80\epsilon_0$  permeability  $\mu = \mu_0$  and resistivity  $\rho = 0.25\text{M}$ . Imagine a parallel plate capacitor immersed in sea water and driven by an alternating voltage source  $V(t) = V_0 \sin(2\pi\nu t)$ . What fraction of the conduction current density is the displacement current density?

A.  $2/3$

B.  $4/9$

C.  $9/4$

D. 2

**Answer: C**



2. An electromagnetic wave travelling along z-axis is given as  $E = E_0 \cos(kz - \omega t)$ . Choose the correct options from the following

A. The associated magnetic field is given as

$$\vec{B} = \frac{1}{c} \hat{k} \times \vec{E} = \frac{1}{\omega} \left( \vec{k} \times \vec{E} \right)$$

B. The electromagnetic field can be written in terms of the associated magnetic field as

$$\vec{E} = c \left( \vec{B} \times \hat{j} \right)$$

C.  $\hat{k} \cdot \vec{E} = 0, \hat{k} \cdot \vec{B} \neq 0$

D.  $\hat{k} \cdot \vec{E} = 0, \hat{k} \times \vec{B} = 0$

**Answer: A**



**Watch Video Solution**

3. A long straight cable of length  $l$  is placed symmetrically along z-axis and has radius  $a$  ( $a \ll l$ ).

The cable consists of a thin wire and a co-axial conducting tube. An alternating current

$I(t) = I_0 \sin(2\pi vt)$ . Flows down the central thin wire and returns along the co-axial conducting tube.

the induced electric at a distance  $s$  from the wire inside the cable is

$$E(s, t) = \mu_0 I_0 v \cos(2\pi vt) \ln\left(\frac{s}{a}\right) \hat{k}.$$

(i) Calculate the displacement current density inside



the cable.

(ii) Integrate the displacement current density across the cross-section of the cable to find the total displacement current  $I^d$ .

(iii) compare the conduction current  $I_0$  with the displacement current  $I_0^d$ .

A.  $\frac{2\pi}{\lambda^2} I_0 \ln\left(\frac{a}{s}\right) \sin(2\pi vt) \hat{k}$

B.  $\frac{1}{\lambda^2} I_0 \ln\left(\frac{a}{s}\right) \sin(2\pi vt) \hat{k}$

C.  $\frac{\pi}{\lambda^2} I_0 \ln\left(\frac{a}{s}\right) \sin(2\pi vt) \hat{k}$

D. Zero

**Answer: A**



**Watch Video Solution**

4. In the question 3, the ratio of conduction current and the displacement current is

A.  $\left(\frac{a\pi}{\lambda}\right)^2$

B.  $\left(\frac{a\pi}{\lambda}\right)$

C.  $\left(\frac{\lambda}{a\pi}\right)^2$

D.  $\left(\frac{\lambda}{2\pi}\right)$

**Answer: A**



**View Text Solution**

5. Poynting vectors  $\vec{S}$  is defined as  $\vec{S} = \frac{1}{\mu_0} \vec{E} \times \vec{B}$ .

The average value of ' $\vec{S}$ ', over a single period 'T' is given by

A.  $E_0^2 / 2c\mu_0$

B.  $E_0^2 / c\mu_0$

C.  $2E_0^2 / c\mu_0$

D.  $E_0^2 / c\mu_0^2$

**Answer: A**



**Watch Video Solution**

6. An infinitely long thin wire carrying a uniform linear static charge density  $\lambda$  is placed along the z-axis Fig. The wire is set into motion along its length with a uniform velocity  $\vec{v} = v\hat{k}$ . Calculate the Poynting

$$\text{vector } \vec{S} = \frac{1}{\mu_0} (\vec{E} \times \vec{B}).$$

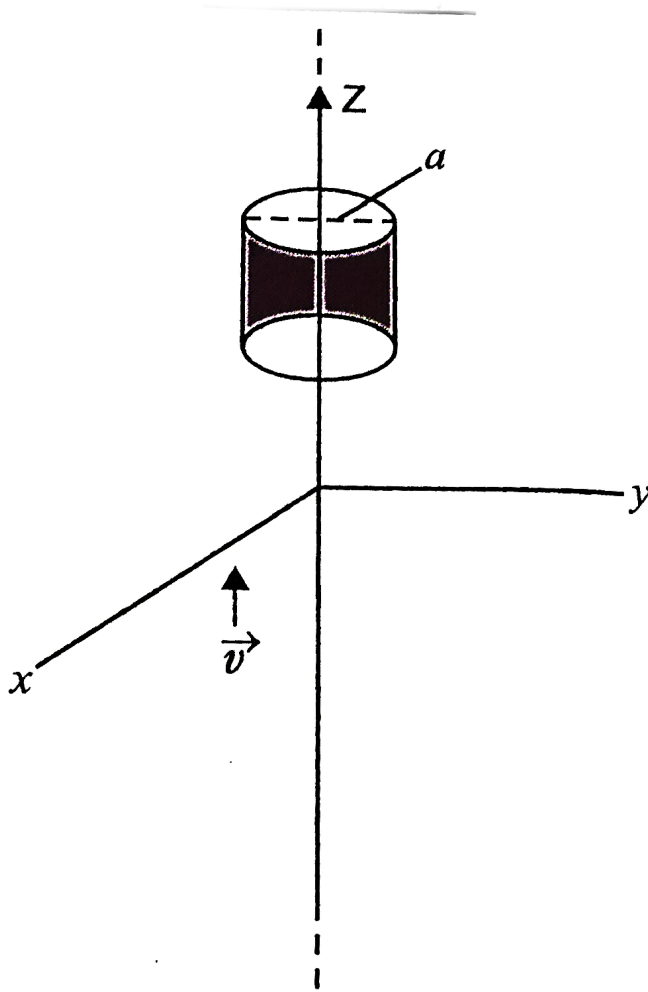

$$\text{A. } \frac{-\lambda^2 v}{4\pi^2 \epsilon_0 a^2} \hat{k}$$

B.  $\frac{\lambda^2 v}{4\pi^2 \epsilon_0 a^2} \hat{i}$

C.  $\frac{\lambda^2 v}{4\pi^2 \epsilon_0 a^2} \hat{k}$

D.  $\frac{-\lambda^2 v}{4\pi^2 \epsilon_0 a^2} \hat{i}$

**Answer: A**



**Watch Video Solution**

7. A plane EM wave travelling along z direction is described by

$$E = E_0 \sin(kz - \omega t) \hat{i} \quad \text{and} \quad B = B_0 \sin(kz - \omega t) \hat{j}.$$

show that

A. The average energy density of the wave is given

$$\text{by } u_{av} = \frac{1}{4}\epsilon_0 E_0^2 + \frac{1}{4} \frac{B_0^2}{\mu_0}$$

B. The time averaged intensity of the wave is given

$$\text{by } I_{av} = \frac{1}{2}c\epsilon_0 E_0^2$$

C. Both (a) and (b)

D. None of these

**Answer: C**



**Watch Video Solution**

8. Suppose that the electric field amplitude of an electromagnetic wave is  $E_0 = 120\text{N/C}$  and that its

frequency is  $50.0\text{MHz}$ .

(a) Determine  $B_0$ ,  $\omega$ ,  $k$  and  $\lambda$ ,

(b) find expressions for  $E$  and  $B$ .

A. The expression of electric field is

$$\vec{E} = 12 \sin\left(\frac{\pi}{3}x - 100\pi \times 10^6 t\right) \hat{j}$$

B. The expression of electric field is

$$\vec{E} = 60 \sin\left(\frac{\pi}{3}x - 100\pi \times 10^6 t\right) \hat{j}$$

C. The expression of magnetic field is

$$\vec{B} = 40 \times 10^{-8} \sin\left(\frac{\pi}{3}x - \pi \times 10^8 t\right) \hat{k}$$

D. Both (a) and (c)

**Answer: D**



**Watch Video Solution**



## Ncert Exemplar

1. One requires  $11eV$  of energy to dissociate a carbon monoxide molecule into carbon and oxygen atoms. The minimum frequency of the appropriate electromagnetic radiation to achieve the dissociation lies in.

- A. visible region
- B. infrared region
- C. ultraviolet region
- D. microwave region

Answer: C



Watch Video Solution

2. A linearly polarised electromagnetic wave given as  $E = E_0 \hat{i} \cos(kz - \omega t)$  is incident normally on a perfectly reflecting wall  $z = a$ . Assuming that the material of the optically inactive, the reflected wave will be give as

A.  $\vec{E}_r = -E_0 \hat{i} \cos(kx - \omega t)$

B.  $\vec{E}_r = E_0 \hat{i} \cos(kz + \omega t)$

C.  $\vec{E}_r = -E_0 \hat{i} \cos(kz + \omega t)$

D.  $\vec{E}_r = E_0 \hat{i} \sin(kz - \omega t)$

**Answer: B**



**Watch Video Solution**

3. Light with an energy flux  $20W/cm^2$  falls on a non-reflecting surface at normal incidence. If the surface has an area of  $30cm^2$ . the total momentum delivered (for complete absorption) during 30 minutes is

A.  $36 \times 10^{-5} \text{kg m/s}$

B.  $36 \times 10^{-4} \text{kg m/s}$

C.  $108 \times 10^4 \text{kg m/s}$

D.  $1.08 \times 10^7 \text{kg m/s}$

**Answer: B**



**Watch Video Solution**

4. The electric field intensity produced by the radiations coming from 100W bulbs at a 3m distance is  $E$ . The electric field intensity produced by the radiations coming from 50W bulb at the same distance is

A.  $\frac{E}{2}$

B.  $2E$

C.  $\frac{E}{\sqrt{2}}$

D.  $\sqrt{2}E$

**Answer: A**



**Watch Video Solution**

5. If  $E$  and  $B$  represent electric and magnetic field vectors of the electromagnetic wave, the direction of propagation of electromagnetic wave is along.

A.  $\vec{E}$

B.  $\vec{B}$

C.  $\vec{B} \times \vec{E}$

D.  $\vec{E} \times \vec{B}$

**Answer: D**



Watch Video Solution

6. The ratio of contributions made by the electric field and magnetic field components to the intensity of an *EM* wave is.

A.  $c : 1$

B.  $c^2 : 1$

C.  $1 : 1$

D.  $\sqrt{c} : 1$

**Answer: C**



Watch Video Solution

7. An  $EM$  wave radiates outwards from a dipole antenna with  $E_0$  as the amplitude of its electric field vector. The electric field  $E_0$  which transports significant energy from the source falls off as

A.  $\frac{1}{r^3}$

B.  $\frac{1}{r^2}$

C.  $\frac{1}{r}$

D. remains constant

**Answer: C**



**Watch Video Solution**

## Assertion And Reason

1. Assertion : Displacement current goes through the gap between the plates of a capacitor when the charge of the capacitor does not change

Reason : The displacement current arises in the region in which the electric field is constant with time.

A. If both assertion and reason are true and reason is the correct explanation of assertion

B. If both assertion and reason are true but reason is not the correct explanation of assertion

C. If assertion is true but reason is false



D. If both assertion and reason are false

**Answer: D**



**Watch Video Solution**

2. Assertion : Electromagnetic waves are transverse in nature

Reason : The electric and magnetic fields in electromagnetic waves are perpendicular to each other and to the direction of propagation.

A. If both assertion and reason are true and reason

is the correct explanation of assertion

- B. If both assertion and reason are true but reason is not the correct explanation of assertion
- C. If assertion is true but reason is false
- D. If both assertion and reason are false

**Answer: A**



**Watch Video Solution**

**3. Assertion :** The electromagnetic wave is transverse in nature

**Reason :** Electromagnetic wave propagates parallel to the direction of electric and magnetic fields.

- A. If both assertion and reason are true and reason is the correct explanation of assertion
- B. If both assertion and reason are true but reason is not the correct explanation of assertion
- C. If assertion is true but reason is false
- D. If both assertion and reason are false

**Answer: C**

 [Watch Video Solution](#)

4. Assertion : The velocity of electromagnetic waves depends on electric and magnetic properties of the

medium

Reason : Velocity of electromagnetic waves in free space is constant.

- A. If both assertion and reason are true and reason is the correct explanation of assertion
- B. If both assertion and reason are true but reason is not the correct explanation of assertion
- C. If assertion is true but reason is false
- D. If both assertion and reason are false

**Answer: B**



[Watch Video Solution](#)

5. Assertion : Electromagnetic waves interact with matter and set up oscillations

Reason : Interaction is independent of the wavelength of the electromagnetic wave.

A. If both assertion and reason are true and reason is the correct explanation of assertion

B. If both assertion and reason are true but reason is not the correct explanation of assertion

C. If assertion is true but reason is false

D. If both assertion and reason are false

**Answer: C**



6. Assertion : Electromagnetic waves carry energy and momentum

Reason : Electromagnetic waves can be polarised.

- A. If both assertion and reason are true and reason is the correct explanation of assertion
- B. If both assertion and reason are true but reason is not the correct explanation of assertion
- C. If assertion is true but reason is false
- D. If both assertion and reason are false

**Answer: B**



Watch Video Solution

7. Assertion : Electromagnetic waves exert radiation pressure

Reason : Electromagnetic waves carry energy.

- A. If both assertion and reason are true and reason is the correct explanation of assertion
- B. If both assertion and reason are true but reason is not the correct explanation of assertion
- C. If assertion is true but reason is false
- D. If both assertion and reason are false

**Answer: A**



**Watch Video Solution**

**8. Assertion :** If earth did not have atmosphere, its average surface temperature would be lower than what it is now

**Reason :** Green house effect of the atmosphere would be absent, if earth did not have atmosphere.

A. If both assertion and reason are true and reason is the correct explanation of assertion

B. If both assertion and reason are true but reason is not the correct explanation of assertion



C. If assertion is true but reason is false

D. If both assertion and reason are false

**Answer: A**



**Watch Video Solution**

**9.** Assertion : The radio and TV signals from broadcasting stations carry energy.

Reason : Electromagnetic waves are capable to carry energy from one place to another.

A. If both assertion and reason are true and reason is the correct explanation of assertion

- B. If both assertion and reason are true but reason is not the correct explanation of assertion
- C. If assertion is true but reason is false
- D. If both assertion and reason are false

**Answer: A**



**Watch Video Solution**

**10. Assertion :** One should not use metal containers in a microwave oven

**Reason :** Only because metal may melt form heating.

- A. If both assertion and reason are true and reason is the correct explanation of assertion
- B. If both assertion and reason are true but reason is not the correct explanation of assertion
- C. If assertion is true but reason is false
- D. If both assertion and reason are false

**Answer: C**

 [Watch Video Solution](#)

11. Assertion : Microwaves are heat waves which is used to heat up food in ovens.

Reason : In ovens, microwaves heat up the vessel first and food inside gets heated up by the transfer of energy from the vessel.

- A. If both assertion and reason are true and reason is the correct explanation of assertion
- B. If both assertion and reason are true but reason is not the correct explanation of assertion
- C. If assertion is true but reason is false
- D. If both assertion and reason are false

**Answer: D**



**Watch Video Solution**

**12. Assertion :** infrared radiation plays an important role in maintaining the average temperature of earth

**Reason :** Infrared radiations are sometimes referred to as heat waves.

A. If both assertion and reason are true and reason is the correct explanation of assertion

B. If both assertion and reason are true but reason is not the correct explanation of assertion

C. If assertion is true but reason is false

D. If both assertion and reason are false

**Answer: B**



**13.** Assertion : Radio waves are diffracted by buildings

Reason : Radio waves are high energy waves.

- A. If both assertion and reason are true and reason is the correct explanation of assertion
- B. If both assertion and reason are true but reason is not the correct explanation of assertion
- C. If assertion is true but reason is false
- D. If both assertion and reason are false

**Answer: C**

**14.** Assertion : Microwaves are better carrier of signals than optical waves

Reason : Microwaves move faster than optical waves.

- A. If both assertion and reason are true and reason is the correct explanation of assertion
- B. If both assertion and reason are true but reason is not the correct explanation of assertion
- C. If assertion is true but reason is false
- D. If both assertion and reason are false

**Answer: D**



**15. Assertion :** The basic difference between various types of electromagnetic waves lies in their wavelength or frequencies

**Reason :** Electromagnetic waves travel through vacuum with the same speed.

- A. If both assertion and reason are true and reason is the correct explanation of assertion
- B. If both assertion and reason are true but reason is not the correct explanation of assertion
- C. If assertion is true but reason is false



D. If both assertion and reason are false

**Answer: A**



**Watch Video Solution**