



PHYSICS

BOOKS - NCERT FINGERTIPS PHYSICS (HINGLISH)

ELECTROSTATIC POTENTIAL AND CAPACITANCE

Electric Potential

1. Which of the following statement is true?

A. Electrostatic force is a conservative force.

B. Potential at a point is the work done per unit charge in bringing a charge from any point to infinity.

C. Electrostatic force is non-conservative.

D. Potential is the product of charge and work.

Answer: A



Watch Video Solution

2. 1 volt is equivalent to

A. $\frac{\text{newton}}{\text{second}}$

B. $\frac{\text{newton}}{\text{coulomb}}$

C. $\frac{\text{joule}}{\text{coulomb}}$

D. $\frac{\text{joule}}{\text{second}}$

Answer: C



Watch Video Solution

3. The work done in bringing a unit positive charge from infinite distance to a point at distance x from a positive charge Q is W . Then the potential ϕ at that point is

A. $\frac{WQ}{x}$

B. W

C. $\frac{W}{x}$

D. WQ

Answer: B



Watch Video Solution

Potential Due To A Point Charge

1. The potential at a point due to charge of $5 \times 10^{-7} C$ located 10 cm away is

A. $3.5 \times 10^5 V$

B. $3.5 \times 10^4 V$

C. $4.5 \times 10^4 V$

D. $4.5 \times 10^5 V$

Answer: C



Watch Video Solution

2. In the question number 4, work done in bringing a charge of 4×10^{-9} C from infinity to that point is

A. $2.4 \times 10^{-4} J$

B. $1.8 \times 10^{-4} J$

C. $3.2 \times 10^{-5} J$

D. $4.1 \times 10^{-5} J$

Answer: B



[View Text Solution](#)

3. Electric field intensity at a point B due to a point charge Q kept at point A is $24NC^{-1}$, and electric potential at B due to the same charge is $12JC^{-1}$. Calculate the distance AB and magnitude of charge.

A. $10^{-6}C$

B. $10^{-7}C$

C. $10^{-10}C$

D. $10^{-9}C$

Answer: D



Watch Video Solution

4. The electric potential at a point in free space due to a charge Q coulomb is $Q \times 10^{11}$ volts. The electric field at that point is

A. $12\pi\epsilon_0 Q \times 10^{22}Vm^{-1}$

B. $4\pi\epsilon_0 Q \times 10^{22}Vm^{-1}$

C. $12\pi\epsilon_0 Q \times 10^{20} Vm^{-1}$

D. $4\pi\epsilon_0 Q \times 10^{20} Vm^{-1}$

Answer: B



Watch Video Solution

5. Two points A and B located in diametrically opposite directions of a point charge of $+2\mu C$ at distances 2.0 m and 1.0 m respectively from it. Determine the potential difference $V_A - V_B$.

A. $3 \times 10^3 V$

B. $6 \times 10^4 V$

C. $-9 \times 10^3 V$

D. $-3 \times 10^3 V$

Answer: C



Watch Video Solution

6. As per this diagram a point charge $+q$ is placed at the origin O . Work done in taking another point charge $-Q$ from the point

$A(0, a)$ to another point $B(a, 0)$ along the straight path AB is:

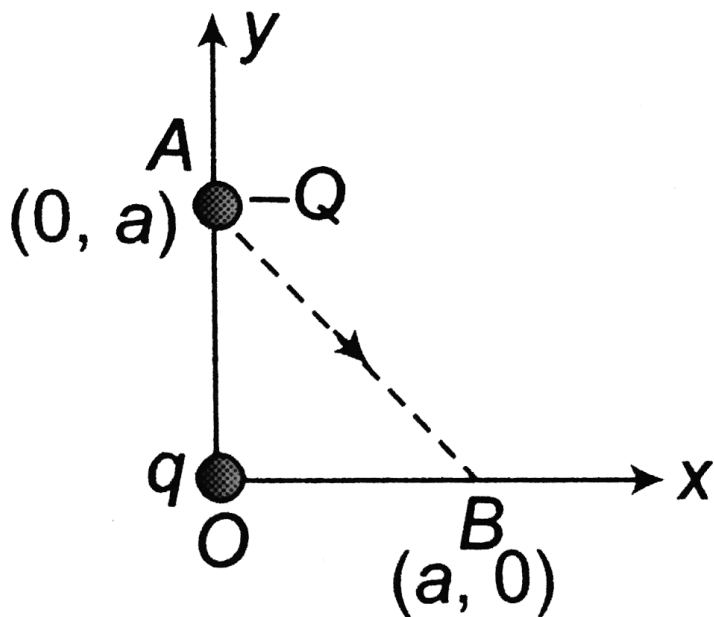

- A. $\frac{qQ}{4\pi\epsilon_0} \left(\frac{a-b}{ab} \right)$
- B. $\frac{qQ}{4\pi\epsilon_0} \left(\frac{b-a}{ab} \right)$
- C. $\frac{qQ}{4\pi\epsilon_0} \left(\frac{b}{a^2} - \frac{1}{b} \right)$

$$D. \frac{qQ}{4\pi\epsilon_0} \left(\frac{a}{b^2} - \frac{1}{b} \right)$$

Answer: A



Watch Video Solution

7. As per this diagram a point charge $+q$ is placed at the origin O . Work done in taking another point charge $-Q$ from the point $A(0, a)$ to another point $B(a, 0)$ along the

straight path AB is:

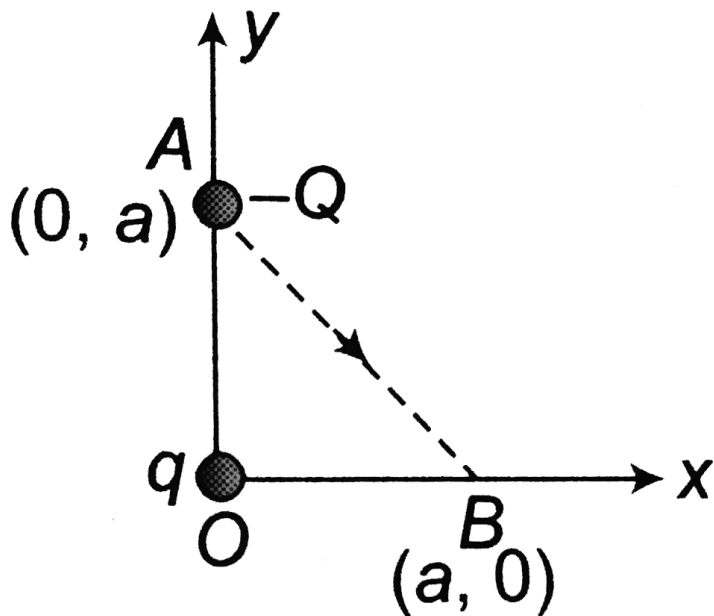

A. zero

B. $\left(\frac{qQ}{4\pi\epsilon_0} \frac{1}{a^2} \right) \sqrt{2a}$

C. $\left(\frac{-qQ}{4\pi\epsilon_0} \frac{1}{a^2} \right) \frac{a}{\sqrt{2}}$

D. $\left(\frac{-qQ}{4\pi\epsilon_0} \frac{1}{a^2} \right) \frac{a}{\sqrt{2}}$

Answer: A



Watch Video Solution

Potential Due To An Electric Dipole

1. Electric field intensity (E) due to an electric dipole varies with distance (r) from the point of the center of dipole as :

A. $\frac{1}{r}$ and $\frac{1}{r^2}$

B. $\frac{1}{r^2}$ and $\frac{1}{r}$

C. $\frac{1}{r^2}$ and $\frac{1}{r^3}$

D. $\frac{1}{r^3}$ and $\frac{1}{r^2}$

Answer: D



Watch Video Solution

2. An electric dipole is placed at the centre of a sphere. Mark the correct options:

A. Electric field is zero at every point of the sphere

B. Electric field is zero anywhere on the sphere

C. The flux of electric field is not zero through the sphere

D. All of these

Answer: B



Watch Video Solution

3. Which of the following is not true ?

A. For a point charge, electrostatic potential varies as $1/r$.

B. For a dipole, the potential depends on the magnitude of position vector and dipole moment vector.

C. The electric dipole potential varies as $1/r$ at large distance.

D. For a point charge, the electrostatic field varies as $1/r^2$.

Answer: C



Watch Video Solution

4. The distance between H^+ and Cl^- ions in HCl molecules is 1.38\AA . The potential due to this dipole at a distance of 10\AA on the axis of dipole is

A. 2.1 V

B. 1.8 V

C. 0.2 V

D. 1.2 V

Answer: C



Watch Video Solution

5. Four points a, b, c and d are set at equal distance from the centre of a dipole as shown in the figure. The magnitudes of electrostatic potential V_a , V_b , V_c and V_d would satisfy

which of the following relation?

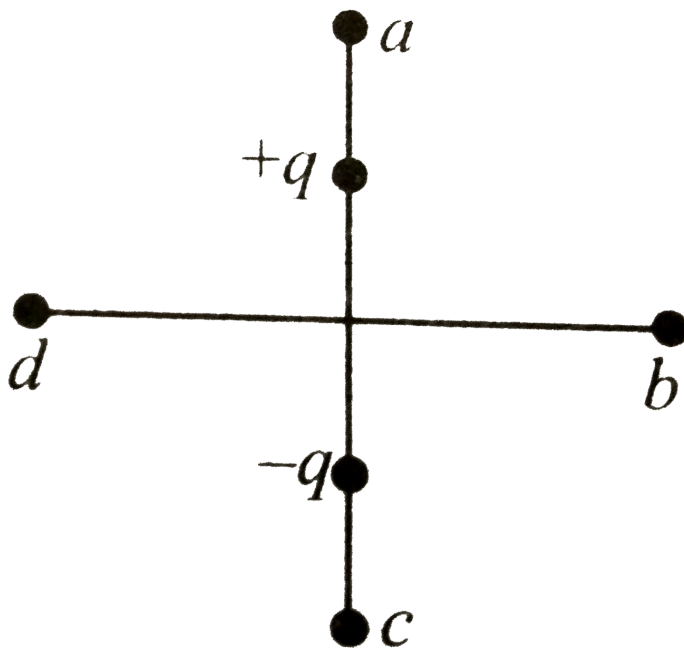

A. $V_a > V_b > V_c > V_d$

B. $V_a > V_b > = V_d > V_c$

C. $V_a = V_c > V_b = V_d$

$$D. V_b = V_d > V_a > V_c$$

Answer: C



Watch Video Solution

Potential Due To A System Of Charges

1. Work done by an electrostatic field in moving a given charge from one point to another upon the chosen.

A. zero

B. positive

C. negative

D. data insufficient

Answer: C



Watch Video Solution

2. Figure shows the field lines of a point negative charge. In going from B to A, the

kinetic energy of a small negative charge will

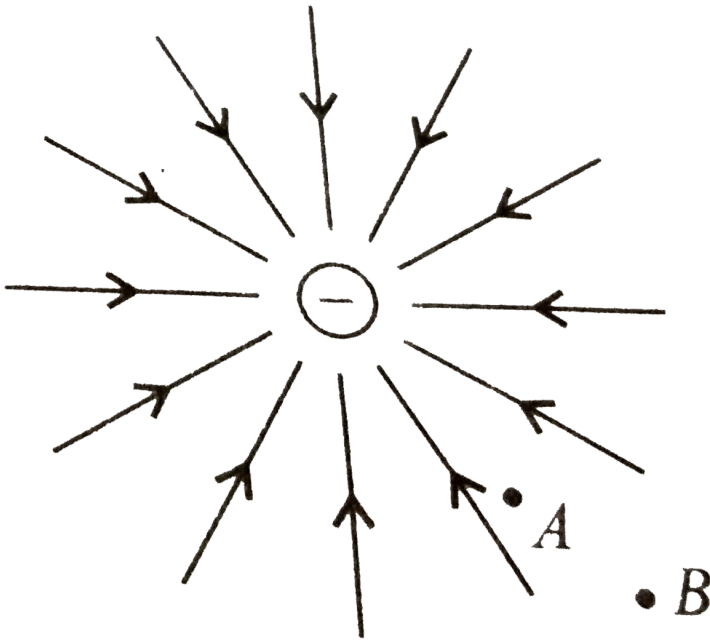

A. increase

B. decrease

C. remain constant

D. data insufficient

Answer: B



Watch Video Solution

3. Two tiny spheres carrying charges $1.8\mu C$ and $2.8\mu C$ are located at 40 cm apart. The potential at the mid-point of the line joining the two charges is

A. $3.8 \times 10^4 V$

B. $2.1 \times 10^5 V$

C. $4.3 \times 10^4 V$

D. $6.3 \times 10^5 V$

Answer: B



Watch Video Solution

4. In the question number 18, the potential at a point 20 cm from the mid-point of the line joining the two charges in a plane normal to the line and passing through the mid-point is

A. $1.4 \times 10^5 V$

B. $4.2 \times 10^3 V$

C. $2.9 \times 10^4 V$

D. $3.7 \times 10^5 V$

Answer: A



View Text Solution

5. Four equal charges Q are placed at the four corners of a square of each side is 'a'. Work

done in removing a charge $-Q$ from its centre
to infinity is

A. zero

B. $\frac{\sqrt{2}Q^2}{\pi\epsilon_0 a}$

C. $\frac{\sqrt{2}Q}{\pi\epsilon_0 a}$

D. $\frac{Q^2}{\pi\epsilon_0 a}$

Answer: B



Watch Video Solution

6. A cube of side b has a charge q at each of its vertices. Determine the potential and electric field due to this charge array at the center of the cube.

A. $\frac{4q}{3\pi\epsilon_0 x}$

B. $\frac{4q}{\sqrt{3}\pi\epsilon_0 x}$

C. $\frac{3q}{4\pi\epsilon_0 x}$

D. $\frac{2q}{\sqrt{3}\pi\epsilon_0 x}$

Answer: B



Watch Video Solution

7. A hexagon of side 8 cm has a charge $4\mu\text{C}$ at each of its vertices. The potential at the centre of the hexagon is

A. $2.7 \times 10^6 \text{ V}$

B. $7.2 \times 10^{11} \text{ V}$

C. $2.5 \times 10^{12} \text{ V}$

D. $3.4 \times 10^4 \text{ V}$

Answer: A





Watch Video Solution

Equipotential Surfaces

1. Consider a uniform electric field in the \hat{z} direction. The potential is a constant.

- A. for any x for a given z
- B. for any y for a given z
- C. on the x - y plane for a given z
- D. All of these

Answer: D



Watch Video Solution

2. Equipotential surfaces

A. are closer in regions of large electric fields compared to regions of lower electric fields

B. will be more crowded near sharp edges of a conductor

C. will always be equally spaced

D. both (a) and (b) are correct

Answer: D



Watch Video Solution

3. In a region of constant potential

A. the electric field is uniform.

B. the electric field is zero.

C. there can be no charge inside the region.

D. both (b) and (c) are correct.

Answer: D



Watch Video Solution

4. What do you understand by potential gradient ?

Establish a relation between electric field and potential gradient.

- A. Electric field is in the direction in which the potential decreases steepest
- B. Magnitude of electric field is given by the change in the magnitude of potential per unit displacement normal to the equipotential surface at the point.
- C. In the region of strong electric field, equipotential surfaces are far apart.
- D. Both the statements (a) and (b) are correct.

Answer: D



Watch Video Solution

5. The angle between the equipotential surface and the electric field (or line of force) at any point on the equipotential surface is

A. 90° always

B. 0° always

C. 0° to 90°

D. 0° to 180°

Answer: A



Watch Video Solution

6. The work done to move a charge along an equipotential from A to B

A. must be defined as $-\int_P^Q \vec{E} \cdot \vec{dl}$

B. is zero

C. can have a non-zero value

D. both (a) and (b) are correct

Answer: D



Watch Video Solution

7. The top of the atmosphere is about 400 kV with respect to the surface of earth, corresponding to an electric field that decreases with altitude. Near the surface of earth the field is about 100 V m^{-1} , but still don't get an electric shock, as we set out of our houses in to open because (assume the house is free from electric field)

A. our body is a perfect insulator

B. our body and ground form an equipotential surface

C. the original equipotential surfaces of open air remain same

D. none of these

Answer: B



Watch Video Solution

8. A hollow conducting sphere is placed in an electric field produced by a point charge placed at P as shown in figure.

Let V_A, V_B, V_C be the potentials at points A, B and C respectively. Then

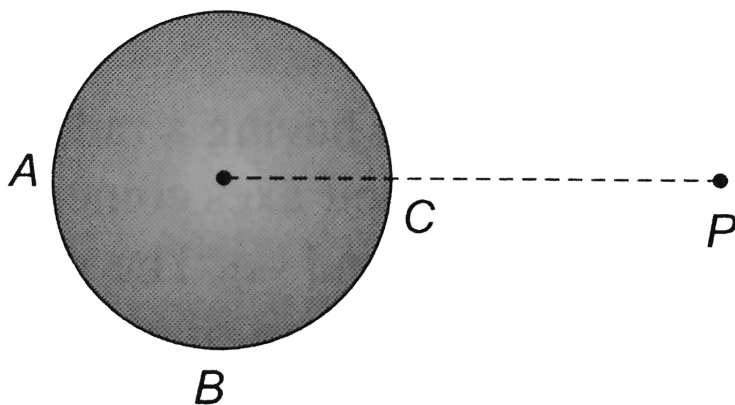

A. $V_C > V_B$

B. $V_A > V_B$

C. $V_B > V_C$

D. $V_A = V_C$

Answer: D



Watch Video Solution

9. The work done in carrying a charge q once round a circle of radius r with a charge Q at the centre is

A. $\frac{qQ}{4\pi\epsilon_0 a}$

B. $\frac{qQ}{4\pi\epsilon_0 a^2}$

C. $\frac{q}{4\pi\epsilon_0 a}$

D. zero

Answer: D



Watch Video Solution

Potential Energy As A System Of Charges

1. When a positive q charge is taken from lower potential to a higher potential point, then its

potential energy will

A. remain the same

B. increase

C. decrease

D. become zero

Answer: C



Watch Video Solution

2. A system consists of two charges $4\mu C$ and $-3\mu C$ with no external field placed at $(-5cm, 0, 0)$ and $(0cm, 0, 0)$ respectively. The amount of work required to separated the two charges infinitely away from each other is

A. $-1.1J$

B. $2J$

C. $2.5J$

D. $3J$

Answer: A



Watch Video Solution

3. Two charges of magnitude $5nC$ and $-2nC$ are placed at points $(2cm,0,0)$ and $(x\text{ cm},0,0)$ in a region of space. Where there is no other external field. If the electrostatic potential energy of the system is $-0.5\mu J$. What is the value of x ?

A. 20 cm

B. 80 cm

C. 4 cm

D. 16 cm

Answer: A



Watch Video Solution

4. (a) In a quark model of elementary particles, a neutron is made of one up quarks [charge $(2/3)e$] and two down quarks [charges $-(1/3)e$]. Assume that they have a triangle

configuration with side length of the order of $10^{-15}m$. Calculate electrostatic potential energy of neutron and compare it with its mass 939 MeV.

(b) Repeat above exercise for a proton which is made of two up and one down quark.

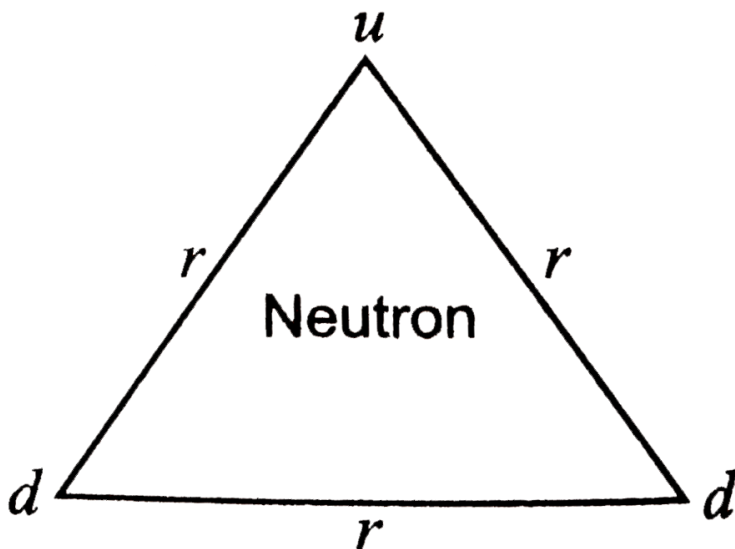

A. 7.68

B. -5.21

C. -0.48

D. 9.34

Answer: C



Watch Video Solution

Potential Energy In An External Field

1. Which among the following statements is true about the work done in bringing a unit

positive charge from point P to Q in an electrostatic field ?

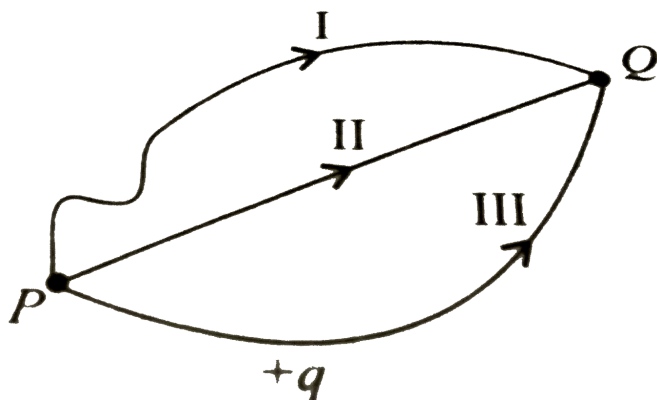

- A. Minimum work is done in case of path II.
- B. Maximum work is done in case of path I.
- C. Work done is same in all the three paths.
- D. Work done is zero in case of path II.

Answer: C



Watch Video Solution

2. A dipole of moment \vec{p} is placed in a uniform electric field \vec{E} . The force on the dipole is \vec{F} and the torque is $\vec{\tau}$

A. (i), (ii) and (iii) are correct

B. (i) and (ii) are correct and (iii) is wrong

C. only (i) is correct

D. (i) and (ii) are correct and (iii) is wrong

Answer: B



Watch Video Solution

3. A molecule of a substance has a permanent electric dipole moment of magnitude 10^{-29}C m . A mole of this substance is polarized at low temperature by applying a strong electrostatic field of magnitude 10^6Vm^{-1} . The direction of the field is suddenly changed by an angle of 60° . Estimate the heat released by the substance in aligning its dipole along the new

direction of the field. For simplicity, assume 100 % polarisation of sample.

A. $-6J$

B. $-3J$

C. $3J$

D. $6J$

Answer: B



Watch Video Solution

4. An electric dipole of length 20 cm having $\pm 3 \times 10^{-3}$ C charge placed at 60° with respect to a uniform electric field experiences a torque of magnitude 6 Nm. The potential energy of the dipole is

A. $-2\sqrt{3}J$

B. $5\sqrt{3}J$

C. $-3\sqrt{2}J$

D. $3\sqrt{5}J$

Answer: A



Watch Video Solution

Electrostatics Of Conductors

1. If a conductor has a potential $V \neq 0$ and there are no charges anywhere else outside, then

A. there must be charges on the surface or inside itself.

B. there cannot be any charge in the body of the conductor.

C. there must be charges only on the surface.

D. both (a) and (b) are correct.

Answer: D



Watch Video Solution

2. Which of the following statements is false for a perfect conductor ?

A. The surface of the conductor is an equipotential surface.

B. The electric field just outside the surface of a conductor is perpendicular to the surface.

C. The charge carried by a conductor is always uniformly distributed over the

surface of the conductor.

D. none of these

Answer: D



Watch Video Solution

3. Consider two conducting spheres of radii R_1 and R_2 with $R_1 > R_2$. If the two are at the same potential, and the larger sphere has more charge than the smaller sphere, then

- A. the charge density of smaller sphere is less than that of larger sphere,
- B. the charge density of smaller sphere is more than that of larger sphere.
- C. both spheres may have same charge density.
- D. none of these

Answer: B



Watch Video Solution

4. Two metal spheres, one of radius R and the other of radius $2R$, both have same surface charge density σ . They are brought in contact and separated. What will be new surface charge densities on them ?

A. $\frac{5}{2}\sigma, \frac{5}{4}\sigma$

B. $\frac{5}{3}\sigma, \frac{5}{6}\sigma$

C. $\frac{3}{5}\sigma, \frac{6}{5}\sigma$

D. $\frac{2}{3}\sigma, \frac{1}{2}\sigma$

Answer: B



Watch Video Solution

5. Two spheres of radius a and b respectively are charged and joined by a wire. The ratio of electric field of the spheres is

A. $\frac{a}{b}$

B. $\frac{b}{a}$

C. $\frac{a^2}{b^2}$

D. $\frac{b^2}{a^2}$

Answer: B



Watch Video Solution

Dielectrics And Polarisation

1. Which among the following is an example of polar molecule ?



Answer: D



Watch Video Solution

2. Choose the correct statement.

A. Polar molecules have permanent electric dipole moment.

B. CO_2 molecule is a polar molecule.

C. H_2O is non-polar molecule.

D. The dipole field at large distances falls of

$$\text{as } \frac{1}{r^2}.$$

Answer: A



Watch Video Solution

3. For metals the value of dielectric constant

(K) is

A. zero

B. infinite

C. 1

D. 10

Answer: B



Watch Video Solution

4. When air is replaced by a dielectric medium of constant K , the maximum force separated by a distance

A. increases K times

B. remains unchanged

C. decreases K times

D. increases K^{-1} times

Answer: C



Watch Video Solution

Capacitors And Capacitance

1. Metallic sphere of radius R is charged to potential V . Then charge q is proportional to

A. V

B. R

C. both V and R

D. none of these

Answer: C



Watch Video Solution

2. A spherical capacitor consists of two concentric spherical conductors, held in position by suitable insulating supports. Show

that the capacitance of this spherical capacitor is given by $C = \frac{4\pi \epsilon_0 r_1 r_2}{r_1 - r_2}$,

Where r_1 and r_2 are radii of outer and inner spheres respectively.

A. $\frac{4\pi\epsilon_0 r_1 r_2}{r_1 - r_2}$

B. $\frac{4\pi\epsilon_0 - (r_2 - r_1)}{r_1 r_2}$

C. $\frac{r_1 r_2}{4\pi\epsilon_0 (r_2 - r_1)}$

D. $\frac{(r_1 - r_2)}{4\pi\epsilon_0 r_1 r_2}$

Answer: A



Watch Video Solution

3. The magnitude of electric field \vec{E} in the annular region of a charged cylindrical capacitor.

A. is the same throughout

B. is higher near the outer cylinder than near the inner cylinder

C. varies as $\frac{1}{r^2}$ where r is the distance from the axis

D. varies as $\frac{1}{r^3}$ where r is the distance from the axis.

Answer: C



Watch Video Solution

4. A cylindrical capacitor has two co-axial cylinders of length 20 cm and radii 1.5 cm and 1.6 cm. The outer cylinder is earthed and inner cylinder is given a charge $4\mu C$. The

capacitance of the system is (neglect end effect)

A. $2.8 \times 10^{-8} F$

B. $4.2 \times 10^{-14} F$

C. $1.7 \times 10^{-10} F$

D. $3.4 \times 10^{-12} F$

Answer: C



Watch Video Solution

1. In a parallel plate capacitor , the capacity increases if

A. area of the plate is decreased

B. distance between the plates increases

C. area of the plate is increased

D. dielectric constant decreases.

Answer: C



Watch Video Solution

2. Two large parallel conducting plates are placed close to each other, the inner surface of the two plates have surface charge densities $+\sigma$ and $-\sigma$. The outer surfaces are without charge. The electric field has a magnitude of

A. $\frac{\sigma}{2\epsilon_0}$

B. $\frac{\sigma}{\epsilon_0}$

C. 0

D. none of these

Answer: B



Watch Video Solution

3. A parallel plate air capacitor is charged to a potential difference of V volts. After disconnecting the charging battery the distance between the plates of the capacitor is increased using an insulating handle. As a result the potential difference between the plates

A. increases

B. decrease

C. does not charge

D. becomes zero

Answer: A



Watch Video Solution

4. A parallel plate capacitor is charged and then isolated. The effect of increasing the

plate separation on charge, potential and capacitance respectively are

A. constant, decrease, decrease

B. increase, decreases, decreases

C. constant, decreases, increases

D. constant, increases, decreases.

Answer: D



Watch Video Solution

5. A parallel plate capacitor is connected to a battery as shown in figure. Consider two situations :

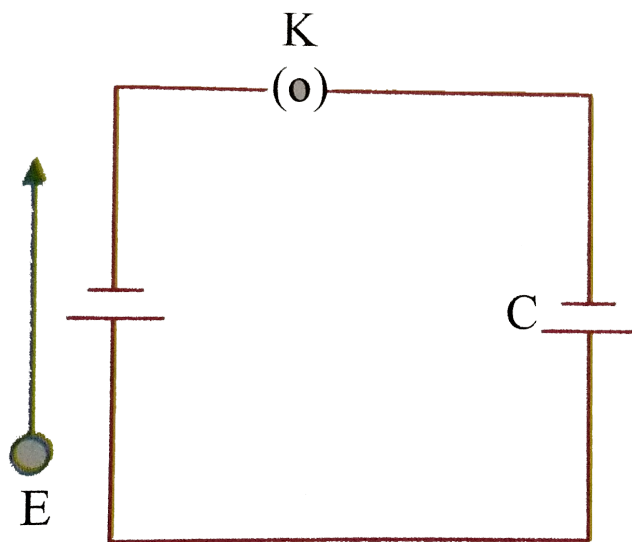

A : Key K is kept closed and plates of capacitors are moved apart using insulating handle.

B : Key K is opened and plates of capacitors are moved apart using insulating handle.

Choose the correct options (s).

A. In (i), Q remains same but C charges.

B. In (ii) V remains same but C charges.

C. In (i) V remains same and hence Q changes.

D. In (ii) both Q and V changes.

Answer: C



Watch Video Solution

Effect Of Dielectric On Capacitance

1. If the dielectric constant and dielectric strength be denoted by K and x respectively, then a material suitable for use as a dielectric in a capacitor must have

- A. high K and high X
- B. high K and low K
- C. low K and high K
- D. low K and low X

Answer: A



Watch Video Solution

2. A parallel plate capacitor with air between the plates has a capacitance of 10 pF. The capacitance, if the distance between the plates is reduced by half and the space between them is filled with a substance of dielectric constant 4 is

A. 80pF

B. 96pF

C. 100pF

D. 120pF

Answer: A



Watch Video Solution

3. The capacitance of a parallel plate capacitor with air as medium is $3\mu\text{F}$. with the introduction of a dielectric medium between

the plates, the capacitance becomes $15\mu F$.

The permittivity of the medium is

A. $5C^2 N^{-1} M^{-2}$

B. $15C^2 N^{-1} m^{-2}$

C. $0.44 \times 10^{-10} C^2 N^{-1} m^{-2}$

D. $8.854 \times 10^{-11} C^2 N^{-1} m^{-2}$

Answer: C



Watch Video Solution

4. A copper plate of thickness b is placed inside a parallel plate capacitor of plate distance d and area A as shown in figure. The

capacitance of capacitor is

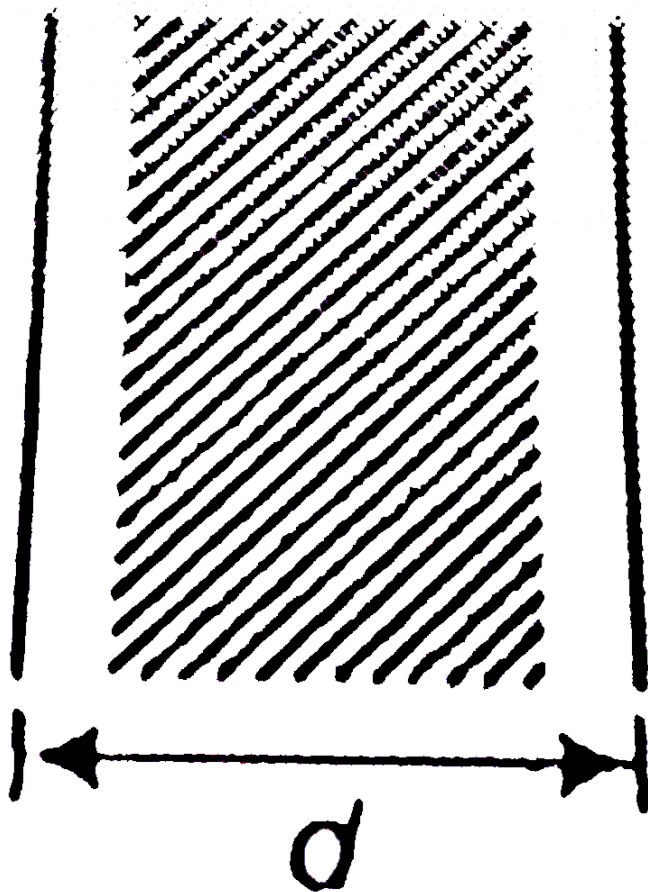

A. $\frac{\epsilon_0 A}{d + \frac{b}{2}}$

B. $\frac{\epsilon_0 A}{2d}$

C. $\frac{\epsilon_0 A}{d - b}$

D. $\frac{2\epsilon_0 A}{d + \frac{b}{2}}$

Answer: C



Watch Video Solution

5. A parallel plate capacitor of capacity $5\mu F$ and plate separation $6cm$ is connected to a $1V$ battery and is charged. A dielectric of dielectric constant 4 and thickness $4cm$ is introduced into the capacitor. The additional

charge that flows into the capacitor from the battery is.

A. $2\mu C$

B. $3\mu C$

C. $5\mu C$

D. $10\mu C$

Answer: C



Watch Video Solution

6. A slab of material of dielectric constant K has the same area as the plates of a parallel capacitor, but has a thickness $\left(\frac{3}{4}d\right)$, where d is the separation of the plates. How is the capacitance changed when the slab is inserted between the plates

A. $C = \frac{\epsilon_0 A}{d} \left(\frac{K + 3}{4K} \right)$

B. $C = \frac{\epsilon_0 A}{d} \left(\frac{2K}{K + 3} \right)$

C. $C = \frac{\epsilon_0 A}{d} \left(\frac{K}{K + 3} \right)$

D. $C = \frac{\epsilon_0 A}{d} \left(\frac{4K}{K + 3} \right)$

Answer: D



Watch Video Solution

Combination Of Capacitors

1. Three capacitors each of capacity $4\mu F$ are to be connected in such a way that the effective capacitance is $6\mu F$. This can be done by

A. connecting them in series

B. connecting them in parallel

C. connecting two in series and one in parallel

D. connecting two in parallel and one in series

Answer: C



Watch Video Solution

2. The equivalent capacitance for the network shown in the figure is

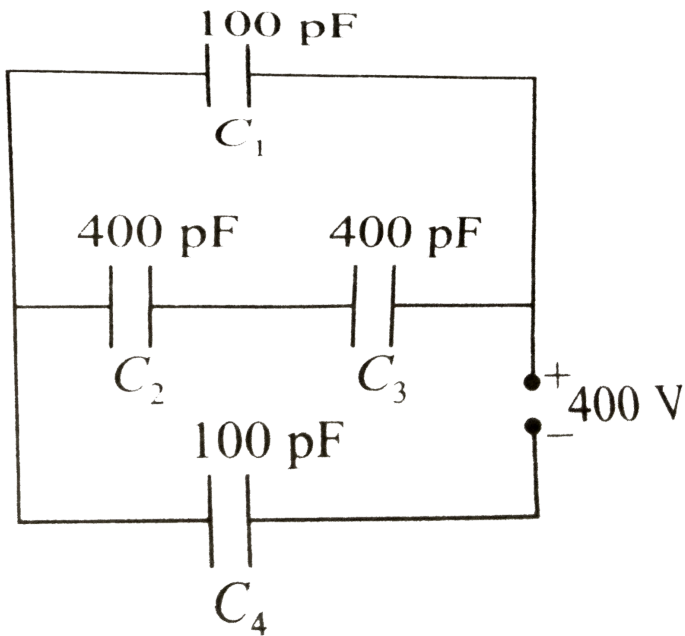

A. $\frac{1200}{7} pF$

B. $\frac{1000}{4} pF$

C. $\frac{1800}{7} pF$

D. $\frac{1300}{3} pF$

Answer: A



Watch Video Solution

3. A network of four $20 \mu F$ capacitors is connected to a 600 V supply as shown in the figure.

The equivalent capacitance of the network is

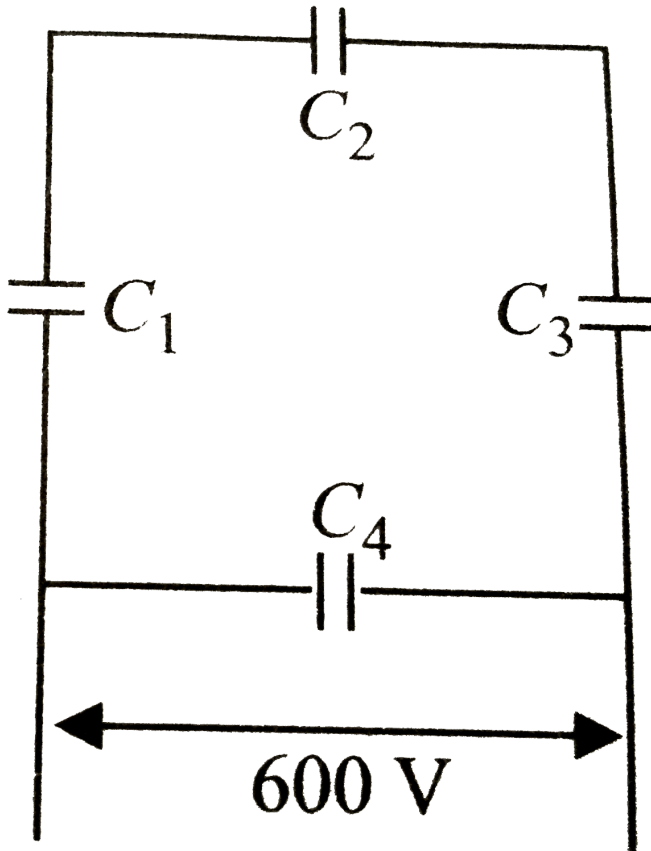

A. $30.26\mu F$

B. $20\mu F$

C. $26.67\mu F$

D. $10\mu F$

Answer: C



Watch Video Solution

4. In the question number 66, the charge on capacitors C_1 and C_4 are

A. $4 \times 10^{-3} C, 12 \times 10^{-3} C$

B. $6 \times 10^{-3} C, 12 \times 10^{-3} C$

C. $2 \times 10^{-3} C, 4 \times 10^{-3} C$

D. $3 \times 10^{-3} C, 2 \times 10^{-3} C$

Answer: A



View Text Solution

5. The charge on $3\mu F$ capacitor shown in the figure is

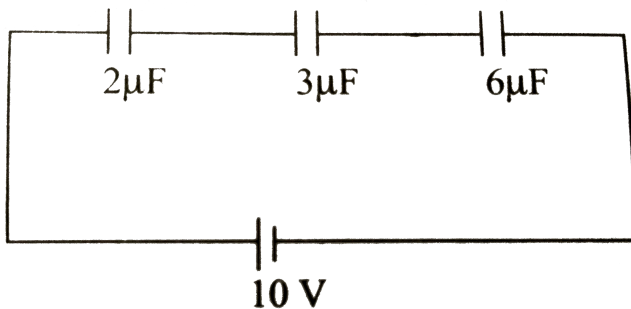

A. $2\mu C$

B. $10\mu C$

C. $6\mu C$

D. $8\mu C$

Answer: B



Watch Video Solution

6. Minimum number of capacitors each of $8\mu F$ and 250 V used to make a composite capacitor of $16\mu F$ and 1000 V are

A. 8

B. 32

C. 16

D. 24

Answer: B



Watch Video Solution

7. A capacitor of capacitance C_1 is charged to a potential V and then connected in parallel to an uncharged capacitor of capacitance C_2 . The

final potential difference across each capacitor

will be

A. $\frac{C_1 V}{C_1 + C_2}$

B. $\frac{C_2 V}{C_1 + C_2}$

C. $1 + \frac{C_2}{C_1}$

D. $1 - \frac{C_2}{C_1}$

Answer: A



Watch Video Solution

8. Two capacitors of $2\mu F$ and $4\mu F$ are connected in parallel. A third capacitor of $6\mu F$ is connected in series. The combination is connected across a 12 V battery. The voltage across $2\mu F$ capacitor is

A. 2 V

B. 8 V

C. 6 V

D. 1 V

Answer: C



Watch Video Solution

9. Two identical capacitors are joined in parallel, charged to a potential V and then separated and then connected in series i.e. the positive plate of one is connected to negative of the other

A. The charges on the free plates connected together are destroyed.

B. The energy stored in the system increases.

C. The potential difference between the free plates is 2V.

D. The potential difference remains constant.

Answer: C



Watch Video Solution

10. In the circuit shown in figure , initially key K_1 is closed and key K_2 is open. Then K_1 is opened and K_2 is closed (order is important). [Take Q'_1 and Q'_2 as charges on C_1 and C_2 and V_1 and V_2 as voltage respectively].

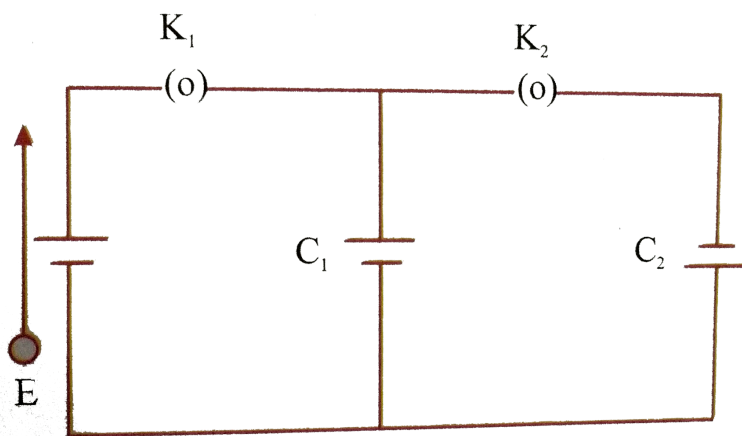

Then

A. charge on C_1 get redistributed such

$$\text{that } V_1 = V_2$$

B. charge on C_1 gas redistributed such

$$\text{that } q_1' = q_2'$$

C. charge on C_1 gets redistributed such

$$\text{that } C_1 V_1 = C_2 V_2 = C_1 V$$

D. charge on C_1 gets redistributed such

$$\text{that } q_1' + q_2' = 2q$$

Answer: A



Watch Video Solution

11. A parallel plate capacitor is made by stacking n equally spaced plates connected alternatively. If the capacitance between any two adjacent plates is ' C ' then the resultant capacitance is

A. nC

B. $\frac{C}{n}$

C. $(n + 1)C$

D. $(n - 1)C$

Answer: D



Watch Video Solution

12. Two parallel conducting plates of area $A = 2.5m^2$ each are placed 6 mm apart and are both earthed. A third plate, identical with the first two, is placed at a distance of 2 mm from one of the earthed plates and is given a charge of 1 C. The potential of the central

plate is

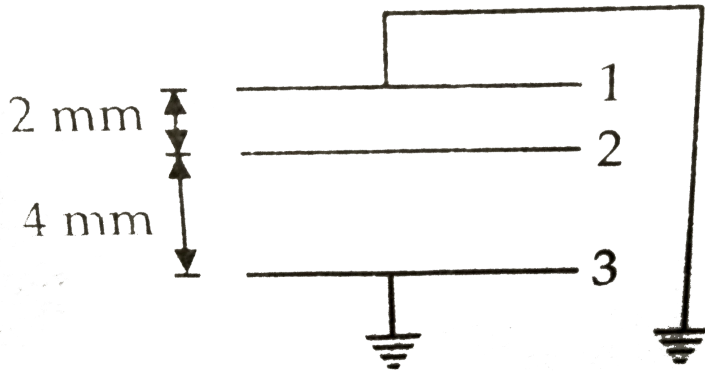

A. $6 \times 10^7 V$

B. $3 \times 10^7 V$

C. $4 \times 10^7 V$

D. $2 \times 10^7 V$

Answer: A



13. A parallel plate air capacitor has a capacitance C . When it is half filled with a dielectric of dielectric constant 5, the percentage increase in the capacitance will be

A. 400 %

B. 66.6 %

C. 33.3 %

D. 200 %

Answer: B



Watch Video Solution

14. A capacitor is made of two circular plates of radius R each, separated by a distance $d \ll R$. The capacitor is connected to a constant voltage. A thin conducting disc of radius $r \ll R$ and thickness $t \ll r$ is placed at a center of the bottom plate. Find the minimum voltage required to lift the disc if the mass of the disc is m .

A. $\frac{\sqrt{mgd}}{\pi\epsilon_0 r^2}$

B. $\sqrt{\frac{mgd}{\pi\epsilon_0 r}}$

C. $\sqrt{\frac{mgd^2}{\pi\epsilon_0 r^2}}$

D. $\sqrt{\frac{mgd}{\pi\epsilon_0 r^2}}$

Answer: C



Watch Video Solution

Energy Stored In Capacitor

1. A parallel plate condenser is charged by connected it to a battery. The battery is disconnected and a glass slab is introduced between the plates. Then

- A. Charge and potential difference.
- B. Potential difference and energy stored.
- C. Energy stored and capacitance.
- D. Capacitance and charge.

Answer: B



Watch Video Solution

2. A capacitor has some dielectric between its plates, and the capacitor is connected to a DC source. The battery is now disconnected and then the dielectric is removed. State whether the capacitance, the energy stored in it, electric field, charge stored and the voltage will increase or remain constant.

A. capacitance will increase.

B. energy stored will decrease.

C. electric field will increase.

D. voltage will decrease.

Answer: C



Watch Video Solution

3. A capacitor of capacitance 700 pF is charged by 100 V battery. The electrostatic energy stored by the capacitor is

A. $2.5 \times 10^{-8} J$

B. $3.5 \times 10^{-6} J$

C. $2.5 \times 10^{-4} J$

D. $3.5 \times 10^{-4} J$

Answer: B



Watch Video Solution

4. A 16 pF capacitor is connected to 70 V supply. The amount of electric energy stored in the capacitor is

A. $4.5 \times 10^{-12} J$

B. $5.1 \times 10^{-8} J$

C. $2.5 \times 10^{-12} J$

D. $3.92 \times 10^{-8} J$

Answer: D



Watch Video Solution

5. A capacitor is charged through a potential difference of 200 V, when 0.1 charge is stored

in it. The amount of energy released by it,
when it is discharged is

A. 5 J

B. 10 J

C. 20 J

D. 2.5 J

Answer: B



Watch Video Solution

6. A parallel plate capacitor has a uniform electric field E in the space between the the plates. If the distance between the plates is d and area of each plate is A , the energy stored in the capacitor is

A. $\frac{1}{2}\epsilon_0 E^2$

B. $\frac{E^2 Ad}{\epsilon_0}$

C. $\frac{1}{2}\epsilon_0 E^2 Ad$

D. $\epsilon_0 E^2 Ad$

Answer: C



Watch Video Solution

7. A metallic sphere of radius 18 cm has been given a charge of $5 \times 10^{-6} C$. The energy of the charged conductor is

A. $0.2J$

B. $0.6J$

C. $1.2J$

D. $2.4J$

Answer: B



Watch Video Solution

8. Two spherical conductors each of capacity C are charged to potential V and $-V$. These are then connected by means of a fine wire. The loss of energy will be

A. zero

B. $\frac{1}{2}CV^2$

C. CV^2

D. $2CV^2$

Answer: C



Watch Video Solution

9. Two condensers, one of capacity C and the other of capacity $C/2$ are connected to a V volt battery, as shown.

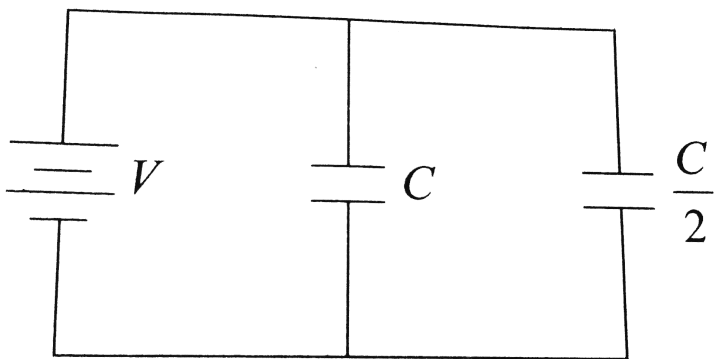

The work done in charging fully both the condensers is

A. $\frac{1}{4}CV^2$

B. $\frac{3}{4}CV^2$

C. $\frac{1}{2}CV^2$

D. $2CV^2$

Answer: B



Watch Video Solution

10. A parallel plate condenser with a dielectric of dielectric constant K between the plates has a capacity C and is charged to a potential V volt. The dielectric slab is slowly removed from between the plates and then reinserted. The net work done by the system in this process is

A. zero

B. $\frac{1}{2}(K - 1)CV^2$

C. $\frac{CV^2(K - 1)}{K}$

$$D. (K - 1)CV^2$$

Answer: A



Watch Video Solution

11. Two identical capacitors, have the same capacitance C . One of them is charged to potential V_1 and the other V_2 . The negative ends of the capacitors are connected together. When the positive ends are also connected,

the decrease in energy of the combined system is

A. $\frac{C}{4} (V_1^2 - V_2^2)$

B. $\frac{C}{4} (V_1^2 + V_2^2)$

C. $\frac{C}{4} (V_1 - V_2)^2$

D. $\frac{C}{4} (V_1 + V_2)^2$

Answer: C



Watch Video Solution

12. Energies stored in capacitor and dissipated during charging a capacitor bear a ratio

A. 1 : 1

B. 1 : 2

C. 2 : 1

D. 1 : 3

Answer: C



Watch Video Solution

13. Two capacitors, $3 \mu F$ and $4 \mu F$, are individually charged across a 6 V battery. After being disconnected from the battery, they are connected together with the negative plate of one attached to the positive plate of the other. What is the final total energy stored ?

A. $1.26 \times 10^{-4} J$

B. $2.57 \times 10^{-4} J$

C. $1.25 \times 10^{-6} J$

D. $2.57 \times 10^{-6} J$

Answer: D



Watch Video Solution

14. A parallel plate capacitor without any dielectric within its plates, has a capacitance C , and is connected to a battery of emf V . The battery is disconnected and the plates of the capacitor are pulled apart until the separation between the plates is doubled. What is the work done by the agent pulling the plates apart, in this process ?

A. $\frac{1}{2}CV^2$

B. $\frac{3}{2}CV^2$

C. $-\frac{3}{2}CV^2$

D. CV^2

Answer: A



View Text Solution

15. A series combination of n_1 capacitors, each of value C_1 , is charged by a source of potential difference $4V$. When another parallel

combination of n_2 capacitors, each of value C_2 , is charged by a source of potential difference V , it has same (total) energy stored in it, as the first combination has. the value of C_2 , in terms of C_1 , is then

A. $\frac{2C_1}{n_1 n_2}$

B. $16 \frac{n_2}{n_1} C_1$

C. $2 \frac{n_2}{n_1} C_1$

D. $\frac{16C_1}{n_1 n_2}$

Answer: D



16. What is the energy stored in the capacitor between terminals a and b of the network shown in the figure? (Capacitance of each capacitor $C = 1\mu F$)

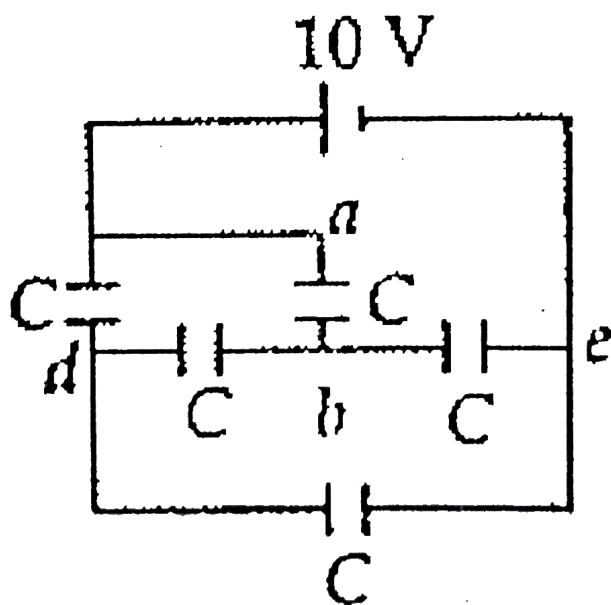

A. $12.5\mu J$

B. Zero

C. $25\mu J$

D. $52\mu J$

Answer: A



Watch Video Solution

17. Consider a parallel plate capacitor with plates 20 cm by 20 cm and separated by 2 mm. The dielectric constant of the material

between the plates is 5. The plates are connected to a voltage source of 500 V. The energy density of the field between the plates will be close to

A. $2.65 J / m^3$

B. $1.95 J / m^3$

C. $1.38 J / m^3$

D. $0.69 J / m^3$

Answer: C



Watch Video Solution

18. The total energy stored in the condensery system shown in the figure will be

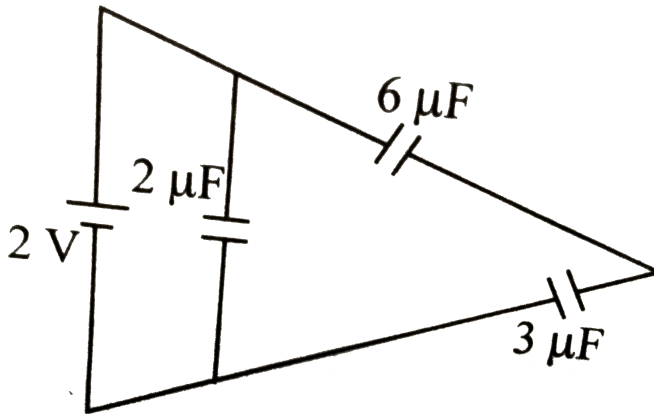

- A. $8\ \mu\text{J}$
- B. $16\ \mu\text{J}$
- C. $2\ \mu\text{J}$
- D. $4\ \mu\text{J}$

Answer: A



Watch Video Solution

Van De Graaff Generator

1. Van de Graaff generator is used for

A. store electrical energy

B. build up high voltages of few million
volts

C. decelerate charged particle like

electrons

D. both (a) and (b) are correct

Answer: B



Watch Video Solution

2. Which of the following statements is/are true about the principle of Van de Graaff generator ?

A. The action of sharp points.

B. The charge given to a hollow conductor is transferred to outer surface and it distributed uniformly over it.

C. It is used for accelerating uncharged particle.

D. Both (a) and (b) are true.

Answer: D



Watch Video Solution

3. Who established the fact of animal electricity ?

A. Van de Graaff

B. Count Alessandro Volta

C. Gustav Robert Kirchhoff

D. Hans Christing Oersted

Answer: B



View Text Solution

4. In case of a Van Graaff generator, the breakdown field of air is

A. $2 \times 10^8 Vm^{-1}$

B. $3 \times 10^6 Vm^{-1}$

C. $2 \times 10^{-8} Vm^{-1}$

D. $3 \times 10^4 Vm^{-1}$

Answer: B



Watch Video Solution

5. In a Van de Graaff type generator, a spherical metal shell is to be $15 \times 10^6 V$ electrode. The dielectric strength of the gas surrounding the electrode is $5 \times 10^7 Vm^{-1}$.

The minimum radius of the spherical shell required is

A. 1 m

B. 2 m

C. 1.5 m

D. 3 m

Answer: D



Watch Video Solution

Higher Order Thinking Skills

1. In a regular polygon of n sides, each corner is at a distance r from the centre. Identical charges are placed at $(n - 1)$ corners. At the centre, the intensity is E and the potential is V . The ratio V / E has magnitude

A. rn

B. $r(n - 1)$

C. $(n - 1) / r$

D. $r(n - 1) / n$

Answer: B



Watch Video Solution

2. The potential at a point distant x (measured in μm) due to some charges situated on the

x-axis is given by $V(x) = \frac{20}{x^2 - 4}$ V. The

electric field at $x = 4\mu\text{m}$ is given by

- A. $\frac{5}{3}V\mu\text{m}^{-1}$ and in positive x direction
- B. $\frac{10}{9}V\mu\text{m}^{-1}$ and in negative x direction
- C. $\frac{10}{9}V\mu\text{m}^{-1}$ and in positive x direction
- D. $\frac{5}{3}V\mu\text{m}^{-1}$ and in negative x direction.

Answer: C



Watch Video Solution

3. An infinite cylinder of radius r_0 , carrying linear charge density λ . The equation of the equipotential surface for the cylinder is

A. $r = r_0 e^{\pi\epsilon_0 [V(r) + V(r_0)] \lambda}$

B. $r = r_0 e^{2\pi\epsilon_0 [V(r) - V(r_0)] \lambda^2}$

C. $r = r_0 e^{-2\pi\epsilon_0 [V(r) - V(r_0)] \lambda}$

D. $r = r_0 e^{-2\pi\epsilon_0 [V(r) - V(r_0)] \lambda}$

Answer: C



Watch Video Solution

4. Three charges Q , $+q$ and $+q$ are placed at the vertices of a right-angled isosceles triangle as shown. The net electrostatic energy of the configuration is zero if Q is equal to

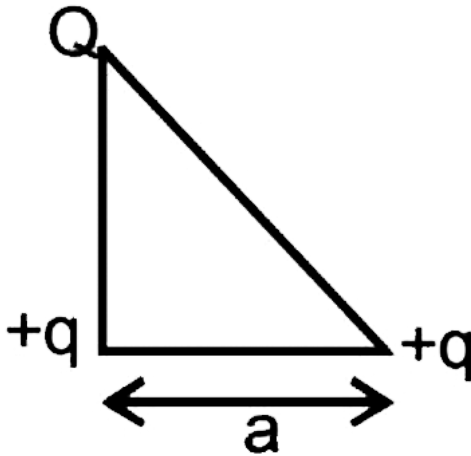

A. $\frac{-q}{1 + \sqrt{2}}$

B. $\frac{-2q}{2 + \sqrt{2}}$

C. $-2q$

D. $+q$

Answer: B



Watch Video Solution

5. Three charges each $+q$, are placed at the corners of an isosceles triangle ABC of sides BC and AC , $2a$, D and E are the mid-points of BC and CA . The work done in taking a

charge Q from D to E is

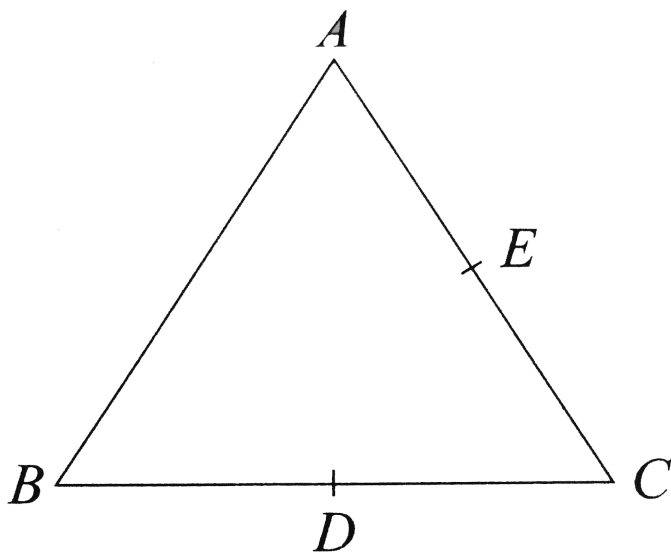

A. $\frac{qQ}{8\pi\epsilon_0 a}$

B. $\frac{qQ}{4\pi\epsilon_0 a}$

C. zero

D. $\frac{3qQ}{4\pi\epsilon_0 a}$

Answer: C



Watch Video Solution

6. Three concentric spherical shells have radii a, b and c ($a < b < c$) and have surface charge densities $\sigma, -\sigma$ and σ respectively. If V_A, V_B and V_C denote the potentials of the three shells, then for $c = 2a + b$, we have

A. $V_C = V_B = V_A$

B. $V_C = V_A \neq V_B$

C. $V_C = V_B \neq V_A$

D. $V_C \neq V_B \neq V_A$

Answer: B



Watch Video Solution

7. A parallel plate capacitor is filled by a dielectric whose relative permittivity varies with the applied voltage (U) as $\epsilon = \alpha U$ where $\alpha = 2V^{-1}$. A similar capacitor with no

dielectric is charged to $U_0 = 78V$. It is then is connected to the uncharged capacitor with the dielectric. Find the final voltage on the capacitors.

A. 2 V

B. 3 V

C. 5 V

D. 6 V

Answer: D



Watch Video Solution

8. For the circuit shown in figure, which of the following statements is true ?

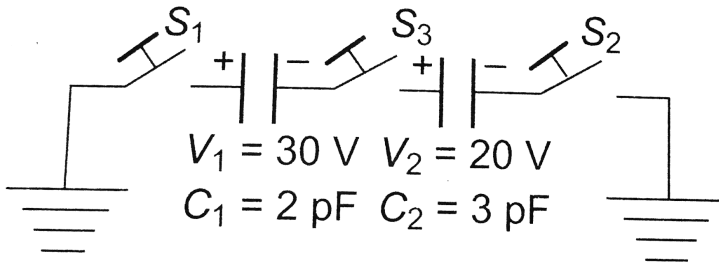

A. With S_1 closed, $V_1 = 15\text{V}$, $V_2 = 20\text{V}$

B. With S_3 closed, $V_1 = V_2 = 25\text{V}$

C. With S_1 and S_2 closed, $V_1 = V_2 = 0$

D. With S_1 and S_3 closed,

$$V_1 = 30\text{V}, V_2 = 20\text{V}.$$

Answer: D



Watch Video Solution

Ncert Exemplar

1. A capacitor of $4\mu F$ is connected as shown in the circuit. The internal resistance of the battery is 0.5Ω . The amount of charge on the

capacitor plates will be

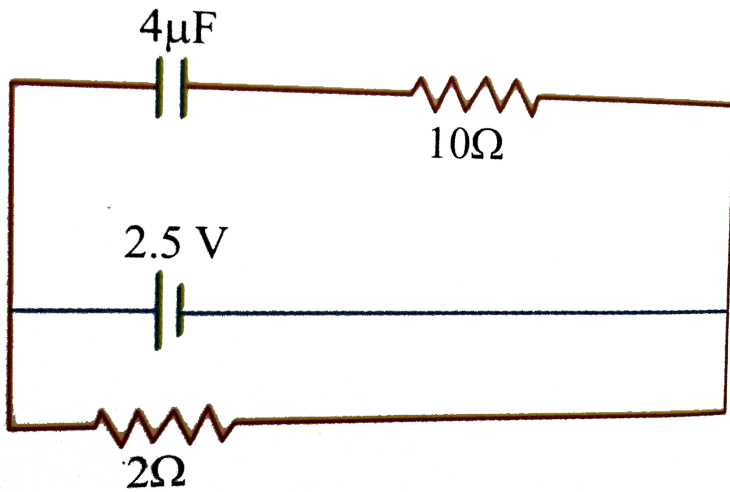

A. 0

B. $4\mu C$

C. $16\mu C$

D. $8\mu C$

Answer: D



Watch Video Solution

2. A positively charged particle is released from rest in a uniform electric field. The electric potential energy of the charge.

A. remains a constant because the electric field is uniform.

B. increases because the charge moves along the electric field.

C. decreases because the charge moves along the electric field.

D. decreases because the charge moves opposite to the electric field.

Answer: C



Watch Video Solution

3. Figure shows some equipotential lines distributed in space. A charged object is

moved from point A to point B .

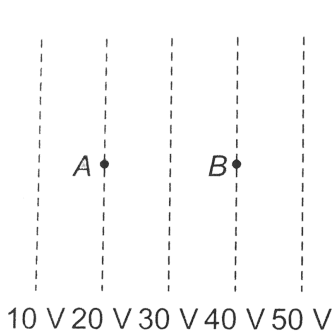

Fig. (i)

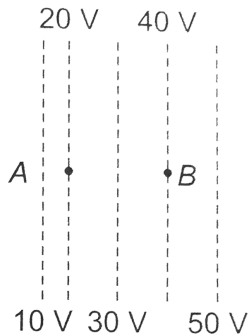

Fig. (ii)

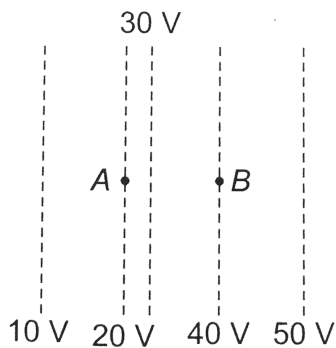

Fig. (iii)

A. The work done in figure (i) is the greatest.

B. The work done in figure (ii) is the least.

C. The work done is the same in figure (i),
(ii) and (iii).

D. The work done in figure (iii) is greater
than figure (ii) but equal to that in figure
(i).

Answer: C



Watch Video Solution

4. The electrostatic potential on the surface of a charged conducting sphere is $100V$. Two statements are made in this regard

S_1 : at any inside the sphere, electric intensity is zero.

S_2 : at any point inside the sphere, the electrostatic potential is $100V$.

A. S_1 is true but S_2 is false

B. Both S_1 and S_2 are false

C. S_1 is true, S_2 is also true and S_1 is the cause of S_2

D. S_1 is true, S_2 is also true but the statements are independent.

Answer: C



Watch Video Solution

5. Equipotentials at a great distance from a collection of charges whose total sum is not zero are approximately

A. spheres

B. planes

C. paraboloids

D. ellipsoids.

Answer: A



Watch Video Solution

6. A parallel plate capacitor is made of two dielectric blocks in series. One of the blocks has thickness d_1 and dielectric constant K_1

and the other has thickness d_2 and dielectric constant K_2 as shown in figure. This arrangement can be through as a dielectric slab of thickness $d(= d_1 + d_2)$ and effective dielectric constant K . The K is.

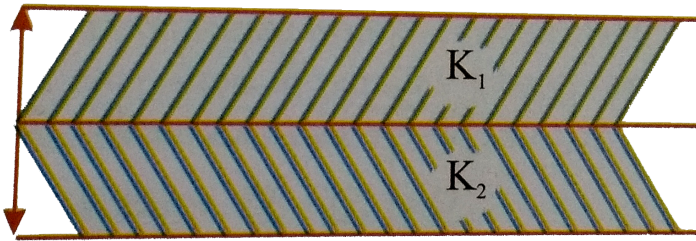

- A. $\frac{K_1 d_1 + K_2 d_2}{d_1 + d_2}$
- B. $\frac{K_1 d_1 + K_2 d_2}{K_1 + K_2}$
- C. $\frac{K_1 K_2 (d_1 + d_2)}{K_2 d_1 + K_1 d_2}$
- D. $\frac{2K_1 K_2}{K_1 + K_2}$

Answer: C



Watch Video Solution

Assertion And Reason

1. Assertion: Work done in moving a charge between any two points in a uniform electric field is independent of the path followed by the charge, between these points.

Reason: Electrostatic forces are non-conservative.

A. If both assertion and reason are true and reason is the correct explanation of assertion.

B. If both assertion and reason are true but reason is not the correct explanation of assertion .

C. If assertion is true but reason is false.

D. If both assertion and reason are false.

Answer: C



Watch Video Solution

2. Electric field inside a conductor can be zero only, if potential inside the conductor is

A. If both assertion and reason are true and reason is the correct explanation of assertion.

B. If both assertion and reason are true but reason is not the correct explanation of assertion .

C. If assertion is true but reason is false.

D. If both assertion and reason are false.

Answer: A



Watch Video Solution

3. Assertion: In case of charged spherical shells, E - r graph is discontinuous while V - r graph is continuous

Reason: According to Gauss's theorem only the charge inside a closed surface can produce electric field at some point.

A. If both assertion and reason are true and reason is the correct explanation of assertion.

B. If both assertion and reason are true but reason is not the correct explanation of assertion .

C. If assertion is true but reason is false.

D. If both assertion and reason are false.

Answer: B



Watch Video Solution

4. Assertion: For a point charge concentric spheres centered at a location of the charge are equipotential surfaces.

Reason : An equipotential surface is a surface over which potential has zero value.

A. If both assertion and reason are true and reason is the correct explanation of assertion.

B. If both assertion and reason are true but reason is not the correct explanation of assertion .

C. If assertion is true but reason is false.

D. If both assertion and reason are false.

Answer: C



Watch Video Solution

5. Assertion: Polar molecules have permanent dipole moment.

Reason : In polar molecule, the centres of positive and negative charges coincide even when there is no external field.

A. If both assertion and reason are true and reason is the correct explanation of assertion.

B. If both assertion and reason are true but reason is not the correct explanation of

assertion .

C. If assertion is true but reason is false.

D. If both assertion and reason are false.

Answer: C



Watch Video Solution

6. Assertion. Dielectric polarization means formation of positive and negative charges inside the dielectric.

Reason. Free electrons are formed in this process.

A. If both assertion and reason are true and reason is the correct explanation of assertion.

B. If both assertion and reason are true but reason is not the correct explanation of assertion .

C. If assertion is true but reason is false.

D. If both assertion and reason are false.

Answer: C



Watch Video Solution

7. Assertion: In the absence of an external electric field, the dipole moment per unit volume of a polar dielectric is zero.

Reason : The dipoles of a polar dielectric are randomly oriented.

A. If both assertion and reason are true and reason is the correct explanation of

assertion.

B. If both assertion and reason are true but reason is not the correct explanation of assertion .

C. If assertion is true but reason is false.

D. If both assertion and reason are false.

Answer: A



Watch Video Solution

8. Can there be a potential difference between two adjacent conductors that carry same amount of positive charge ?

A. If both assertion and reason are true and reason is the correct explanation of assertion.

B. If both assertion and reason are true but reason is not the correct explanation of assertion .

C. If assertion is true but reason is false.

D. If both assertion and reason are false.

Answer: B



Watch Video Solution

9. Assertion: The potential difference between the two conductors of a capacitor is small.

Reason : A capacitor is so configured that it confines the electric field lines within a small region of space.

A. If both assertion and reason are true and reason is the correct explanation of assertion.

B. If both assertion and reason are true but reason is not the correct explanation of assertion .

C. If assertion is true but reason is false.

D. If both assertion and reason are false.

Answer: A



Watch Video Solution

10. Assertion: Increasing the charge on the plates of a capacitor means increasing the capacitance.

Reason : Capacitance is directly proportional to charge.

A. If both assertion and reason are true and reason is the correct explanation of assertion.

B. If both assertion and reason are true but reason is not the correct explanation of assertion .

C. If assertion is true but reason is false.

D. If both assertion and reason are false.

Answer: D



Watch Video Solution

11. As the distance between the plates of a parallel plate capacitor decreased

A. If both assertion and reason are true and reason is the correct explanation of assertion.

B. If both assertion and reason are true but reason is not the correct explanation of assertion .

C. If assertion is true but reason is false.

D. If both assertion and reason are false.

Answer: A



Watch Video Solution

12. Assertion: If distance between the parallel plates of a capacitor is halved, then its capacitance is doubled.

Reason: The capacitance depends on the introduced dielectric.

A. If both assertion and reason are true and reason is the correct explanation of assertion.

B. If both assertion and reason are true but reason is not the correct explanation of assertion .

C. If assertion is true but reason is false.

D. If both assertion and reason are false.

Answer: B



Watch Video Solution

13. Assertion. Capacity of a parallel plate condenser remains unaffected on introduced a conducting or insulating slab between the plates.

Reason. In both the cases, electric field intensity between the plates increases.

A. If both assertion and reason are true and reason is the correct explanation of assertion.

B. If both assertion and reason are true but reason is not the correct explanation of assertion .

C. If assertion is true but reason is false.

D. If both assertion and reason are false.

Answer: D



Watch Video Solution

14. Assertion: Charge on all the condensers connected in series is the same.

Reason : Capacitance of capacitor is directly proportional to charge on it.

A. If both assertion and reason are true and reason is the correct explanation of assertion.

B. If both assertion and reason are true but reason is not the correct explanation of assertion .

C. If assertion is true but reason is false.

D. If both assertion and reason are false.

Answer: C



Watch Video Solution

15. Statement-1. In a series combination of capacitors, charge on each capacitor is same.

Statement-2. In such a combination, charge cannot move only along one route.

A. If both assertion and reason are true and reason is the correct explanation of assertion.

B. If both assertion and reason are true but reason is not the correct explanation of assertion .

C. If assertion is true but reason is false.

D. If both assertion and reason are false.

Answer: C



Watch Video Solution

