



# PHYSICS

## BOOKS - MTG PHYSICS (ENGLISH)

### MECHANICAL PROPERTIES OF FLUIDS

#### Mcqs Corner

1. Pressure applied to an enclosed fluid is transmitted undiminished to every portion of

the fluid and the walls of the containing vessel. This law was first formulated by

A. Reynolds

B. Bernoulli

C. Pascal

D. Torricelli

**Answer: C**



**Watch Video Solution**

2. Which of the following conversions is correct ?

A.  $1 \text{ atm} = 1.01 \times 10^4 \text{ Pa}$

B.  $1 \text{ mm of Hg} = 133 \text{ Pa}$

C.  $1 \text{ bar} = 10^7 \text{ Pa}$

D.  $1 \text{ torr} = 10^2 \text{ Pa}$

**Answer: B**



**Watch Video Solution**

3. Pressure is a scalar quantity, because

A. it is the ratio of force to area and both force and area are vectors.

B. it is the ratio of the magnitude of the force to area

C. it is the ratio of the component of the force normal to the area

D. it depends on the size of the area chosen.



**Answer: C**



**Watch Video Solution**

**4.** Pressure at a point inside a liquid does not depend on

A. the nature of the liquid

B. shape of the container

C. the depth of point below the surface of  
the liquid

D. acceleration due to gravity at that point

**Answer: B**



**Watch Video Solution**

5. The two femurs each of cross-sectional area  $10\text{cm}^2$  support the upper part of a human body of mass 40 kg. the average pressure sustained by the femurs is (take  $g = 10\text{ms}^{-2}$ )

A.  $2 \times 10^2 \text{Nm}^{-2}$

B.  $2 \times 10^4 Nm^{-2}$

C.  $2 \times 10^5 Nm^{-2}$

D.  $2 \times 10^6 Nm^{-2}$

**Answer: C**



**Watch Video Solution**

**6.** A 50 kg girl wearing heel shoes balances on a single heel. The heel is circular with a diameter 1 cm. The pressure exerted by the

heel on the horizontal floor is

$$(Take\ g = 10\text{ms}^{-2})$$

A.  $6.4 \times 10^4$  Pa

B.  $6.4 \times 10^5$  Pa

C.  $6.4 \times 10^6$  Pa

D.  $6.4 \times 10^7$  Pa

**Answer: C**



**Watch Video Solution**

7. Two syringes of different cross-section (without needle filled with water are connected with a tightly fitted rubber tube filled with water. Diameters of the smaller piston and larger piston are  $1\text{cm}$  and  $3\text{cm}$  respectively. If a force of  $10\text{N}$  is applied to the smaller piston then the force exerted on the larger piston is

A.  $30\text{N}$

B.  $60\text{N}$

C.  $90\text{N}$

D. 100 N

**Answer: C**



**Watch Video Solution**

8. In the previous question if the smaller piston is pushed in through  $6\text{cm}$ , how much does the longer piston move out?

A.  $\frac{2}{3}$  cm

B.  $\frac{3}{2}$  cm

C.  $\frac{1}{3}$  cm

D.  $\frac{1}{2}$  cm

**Answer: A**



**View Text Solution**

9. To what height should a cylindrical vessel be filled with a homogeneous liquid to make the force with which the liquid pressure on the sides of the vessel equal to the force

exerted by the liquid on the bottom of the vessel ?

A. equal to the radius

B. less than radius

C. more than radius

D. four times of radius

**Answer: A**



**Watch Video Solution**



10. A U tube contains water and methylated spirit separated by mercury. The mercury columns in the two arms are at the same level with 10 cm of water in one arm and 12.5 cm of spirit in the other as shown in figure. The relative density of the spirit is

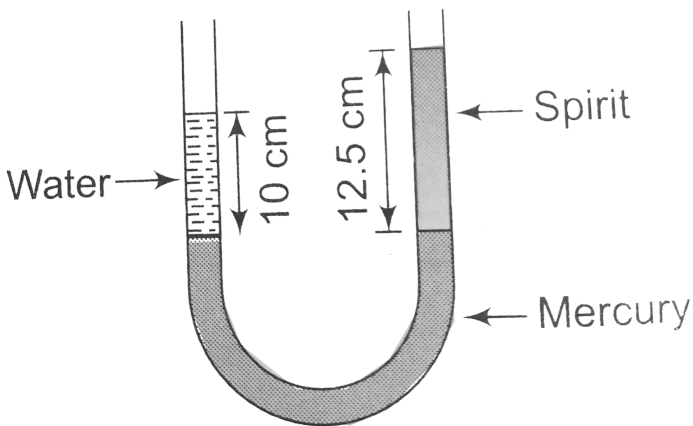

A. 0.6

B. 0.8

C. 1

D. 1.25

**Answer: B**



**Watch Video Solution**

**11.** in previous question, if 15 cm of water and spirit each are further poured into the respective arms of the tube. Difference in the

level of mercury in the two arms is (Take, relative density of mercury = 13.6)

A. 0.20 cm

B. 0.22 cm

C. 0.27 cm

D. 0.26 cm

**Answer: B**



**View Text Solution**

12. In a wind tunnel experiment the pressure on the upper and lower surfaces of the wings are  $0.90 \times 10^5$  Pa and  $0.91 \times 10^5$  Pa respectively. If the area of the wings is  $40\text{m}^2$  the net lifting force on the wing is

A.  $2 \times 10^4\text{N}$

B.  $4 \times 10^4\text{N}$

C.  $6 \times 10^4\text{N}$

D.  $8 \times 10^4\text{N}$

**Answer: B**



Watch Video Solution

13. Three vessels A,B,and C of different shapes contain a water upto the same height as shown in the figure . $P_A$ ,  $P_B$  ,and  $P_C$  be the pressure exerted by the water at the bottom of the vessels A ,B and C respectively . Then

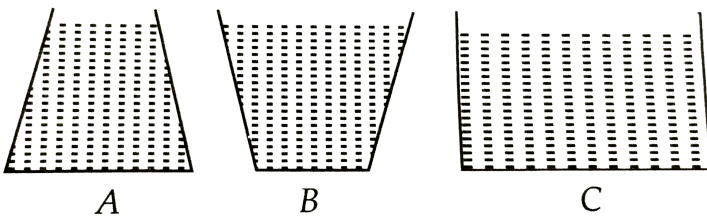

A.  $P_A > P_B > P_C$

B.  $P_B > P_C > P_A$

C.  $P_C > P_B > P_A$

D.  $P_A = P_B = P_C$

**Answer: D**



**Watch Video Solution**

**14.** Which of the following instrument is used to measure gauge pressure ?

A. Thermometer

B. Barometer

C. Manometer

D. Hydrometer

**Answer: C**



**Watch Video Solution**

**15.** A manometer reads the pressure of a gas in an enclosure as shown in the figure. The absolute and gauge pressure of the gas in cm

of mercury is (take atmospheric pressure =76  
cm of mercury)

A. 76,20

B. 20,76

C. 96,20

D. 20,96

**Answer: C**



**View Text Solution**



**16.** The pressure at depth  $h$  below the surface of a liquid of density  $\rho$  open to the atmosphere is

A. greater than the atmospheric pressure

by  $\rho gh$

B. less than the atmospheric pressure by

$\rho gh$

C. equal to the atmospheric pressure

D. increases exponentially with depth

**Answer: A**



**Watch Video Solution**

**17.** The force acting on a window of area  $50 \times 50$  cm of a submarine at a depth of 2000 m in an ocean, the interior of which is maintained at sea level atmospheric pressure is (density of sea water =  $10^3 \text{ kg m}^{-3}$ ,  $g = 10 \text{ m s}^{-2}$ )

A.  $5 \times 10^5 \text{ N}$

B.  $25 \times 10^5 \text{ N}$

C.  $5 \times 10^6 \text{N}$

D.  $25 \times 10^6 \text{N}$

**Answer: C**



**Watch Video Solution**

**18.** A tank with a square base of area  $2m^2$  is divided into two compartments by a vertical partition in the middle. There is a small hinged door of face area  $20cm^2$  at the bottom of the partition. Water is filled in one compartment

and an acid of relative density 1.5 in the other, both to a height of 4m. The force necessary to keep the door closed is ( $Takeg = 10ms^{-2}$ )

A. 10N

B. 20 N

C. 40 N

D. 80 N

**Answer: C**



**View Text Solution**

19. Some iron beads are embedded in wax ball which is just floating in water. The volume of ball is  $18 \text{ cm}^3$  and relative density of wax is 0.9. Then mass of the iron trapped in the ball is

A. 1.8 g

B. 2.7 g

C. 16.8 g

D. 8.1 g

**Answer: A**



**View Text Solution**

20. Hydraulic brakes are based on

- A. Pascal's law
- B. Torricelli's law
- C. Newton's law
- D. Boyle's law

**Answer: A**



**Watch Video Solution**

21. A piece of solid weighs 120 g in air ,80 g in water and 60 kg in a liquid . The relative density of the solid and that of the liquid are respectively

A. 2,  $\frac{1}{2}$

B. 2,  $\frac{3}{2}$

C. 3,  $\frac{1}{2}$

D. 3,  $\frac{3}{2}$

**Answer: D**



**Watch Video Solution**

22. A block of wood floats in water with  $(4/5)th$  of its volume submerged. If the same block just floats in a liquid, the density of liquid in  $(kgm^{-3})$  is

A. 1250

B. 600

C. 400

D. 800

**Answer: D**





Watch Video Solution

23. Iceberg floats in sea water with a part of it submerged. The percentage fraction of the ice berg not submerged is (density of ice =  $0.9gcm^{-3}$ , density of sea water =  $1.1gcm^{-3}$ )

A. 18 %

B. 12 %

C. 10 %

D. 8 %

**Answer: A**



**Watch Video Solution**

**24.** A body of mass 100 kg and density  $500 \text{ kg m}^{-3}$  floats in water. The additional mass should be added to the body so that the body will sink is

A. 80 kg

B. 100 kg

C. 150 kg

D. 200 kg

**Answer: B**



**Watch Video Solution**

**25.** A man is sitting in a boat which is floating in a pond. If the man drinks some water from the pond, the level of water in the pond

A. increases

B. decreases

C. remain unchanged

D. increases or decreases depends upon  
the weight of man

**Answer: C**



**Watch Video Solution**

**26.** An ice block having two similar metallic pieces is floating in water in a vessel as shown in figure. After sometimes the ice melts

completely then

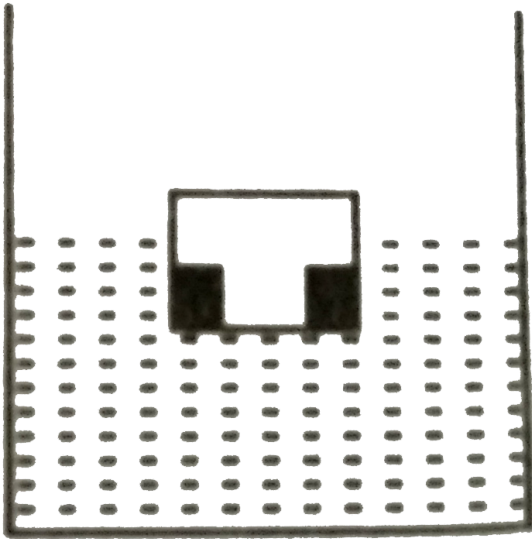

- A. the water level rises in water
- B. the water level falls in the vessel
- C. the water level does not change in vessel

D. the water level may rise or fall depending upon the ratio of masses of ice and metallic pieces

**Answer: B**



**Watch Video Solution**

27. An adulterated sample of milk has a density  $1032\text{kgm}^{-3}$ , while pure milk has a density of  $1080\text{kgm}^{-3}$ . Then the volume of pure milk in a sample of 10 litres of adulterated milk is

A. 1 litre

B. 2 litre

C. 3 litre

D. 4 litre

**Answer: D**



**Watch Video Solution**

**28.** A body is just floating on the surface of a liquid. The density of the body is the same as

that of the liquid. The body is slightly pushed down. What will happen to the body?

- A. come back slowly to its earlier position
- B. remain submerged where it is left
- C. sink in liquid
- D. come out vigoursly

**Answer: C**



**Watch Video Solution**



29. Streamline flow is more likely for liquid with

A. 1. high density and high viscosity

B. 2. low density and low viscosity

C. 3. high density and low viscosity

D. 4. low density and high viscosity

**Answer: D**



**Watch Video Solution**

**30.** When the flow parameters of any given instant remain same at every point, then flow is said to be

- A. 1. laminar
- B. 2. steady state
- C. 3. turbulent
- D. 4. quasistatic

**Answer: B**



**Watch Video Solution**

**31.** An ideal flow of any fluid must satisfy

- A. 1. Pascal law
- B. 2. Stokes' law
- C. 3. Continuity equation
- D. 4. Bernoulli's theorem

**Answer: C**



**Watch Video Solution**

**32.** Water is flowing continuously from a tap having an internal diameter  $8 \times 10^{-3} \text{m}$ . The water velocity as it leaves the tap is  $0.4 \text{ms}^{-1}$ . The diameter of the water stream at a distance  $2 \times 10^{-1} \text{m}$  below the tap is close to ( $g = 10 \text{m} / \text{s}^2$ )

A.  $5.0 \times 10^{-3} \text{ m}$

B.  $7.5 \times 10^{-3} \text{ m}$

C.  $9.6 \times 10^{-3} \text{ m}$

D.  $3.6 \times 10^{-3} \text{ m}$

**Answer: D**



**Watch Video Solution**

**33.** In the figure, an ideal liquid flows through the tube, which is of uniform cross section. The liquid has velocities  $v_A$  and  $v_B$ , and pressures  $P_A$  and  $P_B$  at the points  $A$  and  $B$ , respectively. Then

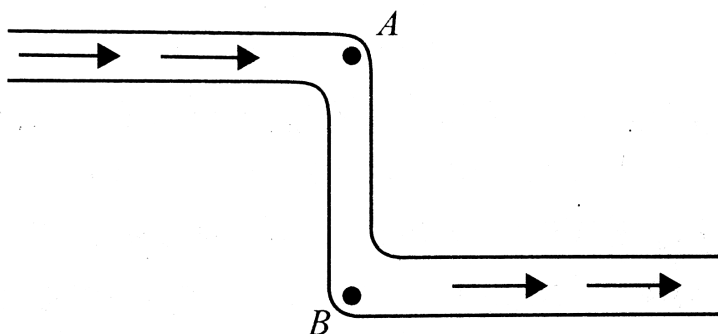

A.  $v_B > v_A$

B.  $v_B = v_A$

C.  $P_B < P_A$

D.  $P_B = P_A$

**Answer: B**



**Watch Video Solution**

**34.** An ideal fluid flows through a pipe of circular cross-section made of two sections

with diameters  $2.5\text{cm}$  and  $3.75\text{cm}$ . The ratio of the velocities in the two pipes is

A.  $9:4$

B.  $3:2$

C.  $\sqrt{3}:\sqrt{2}$

D.  $\sqrt{2}:\sqrt{3}$

**Answer: A**



**Watch Video Solution**

**35.** The cylindrical tube of a spray pump has a cross-section of  $6\text{cm}^2$  one of which has 50 holes each of diameter 1 mm. If the liquid flow inside the tube is 1.2 m per minutes, then the speed of ejection of the liquid through the holes is

A.  $1.21\text{ms}^{-1}$

B.  $0.31\text{ms}^{-1}$

C.  $0.96\text{ms}^{-1}$

D.  $3.4\text{ms}^{-1}$



**Answer: B**



**View Text Solution**

**36.** Bernoulli's equation for steady, non-viscous, incompressible flow expresses the

- A. 1. conservation of linear momentum
- B. 2. conservation of angular momentum
- C. 3. conservation of energy
- D. 4. conservation of mass

**Answer: C**



**Watch Video Solution**

**37.** In old age arteries carrying blood in the human body become narrow resulting in an increase in the blood pressure, this follows from

- A. 1. Pascal's law
- B. 2. Stokes' law
- C. 3. Bernoulli's principle

## D. 4. Archimede's principle

**Answer: C**



**Watch Video Solution**

**38.** Applications of Bernoulli's theorem can be seen in

A. 1. dynamic lift of aeroplane

B. 2. hydraulic press

C. 3. helicopter

D. 4. none of these

**Answer: A**



**Watch Video Solution**

**39.** A liquid flows through a horizontal tube as shown in figure. The velocities of the liquid in the two sections, which have areas of cross-section  $A_1$  and  $A_2$  and  $v_1$  and  $v_2$  respectively. The difference in the levels of the liquid in the

two vertical tubes is  $h$ . then

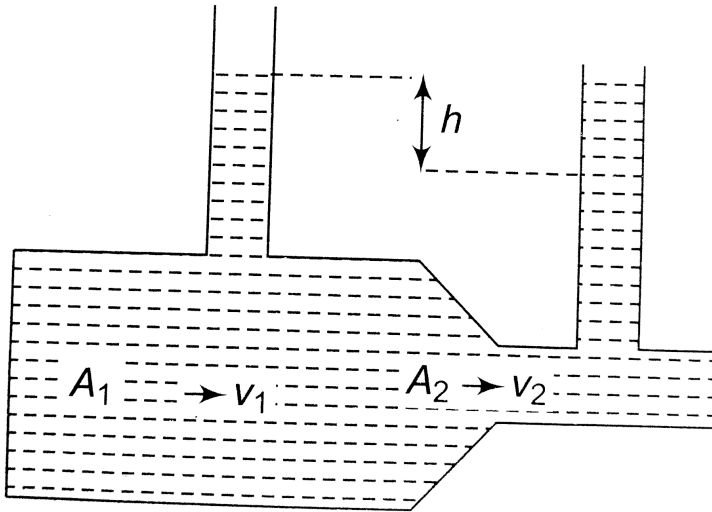

A.  $v_2^2 - v_1^2 = 2gh$

B.  $v_2^2 + v_1^2 = 2gh$

C.  $v_2^2 - v_1^2 = gh$

D.  $v_2^2 + v_1^2 = gh$

**Answer: A**



**Watch Video Solution**

**40.** Which of the following figures shown below is correct regarding the steady flow of a non viscous liquid ?

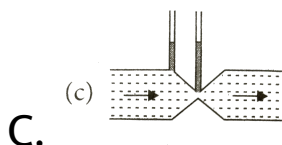
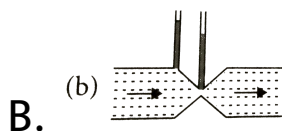
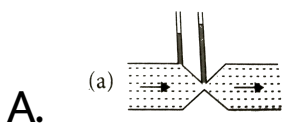

D.

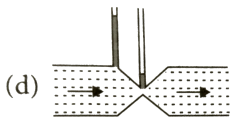

**Answer: A**



**Watch Video Solution**

**41.** An aircraft of mass  $4 \times 10^5 \text{ kg}$  with total wing area  $500 \text{ m}^2$  in level flight at a speed of  $720 \text{ kmh}^{-1}$ . The density of air at its height is  $1.2 \text{ kgm}^{-3}$ . The fractional increase in the speed of the air on the upper surface of its

wings relative to the lower surface is (take

$$g = 10ms^{-2})$$

A. 0.04

B. 0.08

C. 0.17

D. 0.34

**Answer: C**



**Watch Video Solution**



42. A plane is in level flight at constant speed and each of its two wings has an area of  $25m^2$ . If the speed of the air on the upper and lower surfaces of the wing are  $270kmh^{-1}$  and ' $234 km h^{(-1)}$ ' respectively, then the mass of the plane is (Take the density of the air  $= 1kgm^{-3}$ )

A. 1550 kg

B. 1750 kg

C. 3500 kg

D. 3200 kg

**Answer: C**



**Watch Video Solution**

**43.** A tank filled with fresh water has a hole in its bottom and water is flowing out of it. If the size of the hole is increased, then

A. the volume of water flowing out per second will decrease

B. the velocity of outflow of water remains unchanged

C. the volume of water volume out per second remains zero

D. Both (b) and (c)

**Answer: B**



**Watch Video Solution**

**44.** A water barrel stands on a table of height  $h$ . If a small hole is punched in the side of the barrel at its base, it is found that the resultant stream of water strikes the ground at a horizontal distance  $R$  from the table. What is the depth of water in the barrel?

A.  $\frac{R^2}{h}$

B.  $\frac{R^2}{2h}$

C.  $\frac{R^2}{4h}$

D.  $\frac{4R^2}{h}$

**Answer: C**



**Watch Video Solution**

**45.** Torricelli's barometer used mercury but pascal duplicated it using French wine of density  $984\text{kgm}^{-3}$ . In that case, the height of the wine column for normal atmospheric pressure is

(Take the density of mercury  
 $= 1.36 \times 10^3\text{kgm}^{-3}$ )

A. 5.5 m

B. 10.5 m

C. 9.8 m

D. 15 m

**Answer: B**



**Watch Video Solution**

**46.** A cylinder of height 20 m is completely filled with water. The velocity of efflux of water

through a hole on the side wall of the cylinder near its bottom is (Take  $g = 10\text{ms}^{-2}$ )

A.  $10\text{ms}^{-1}$

B.  $20\text{ms}^{-1}$

C.  $25.5\text{ m s}^{-1}$

D.  $5\text{ms}^{-1}$

**Answer: B**



**Watch Video Solution**

47. At What velocity does water emerge from an orifice in a tank in which gauge pressure is  $3 \times 10^5 \text{ Nm}^{-2}$  before the flow starts ? (Take the density of water =  $1000 \text{ kgm}^{-3}$ .)

A.  $24.5 \text{ ms}^{-1}$

B.  $14.5 \text{ ms}^{-1}$

C.  $34.5 \text{ ms}^{-1}$

D.  $44.5 \text{ ms}^{-1}$

**Answer: A**



Watch Video Solution



**48.** Which of the following device is used to measure the rate of liquid through a pipe ?

A. Thermometer

B. Barometer

C. Manometer

D. Venturimeter

**Answer: D**



**Watch Video Solution**

**49.** The flow of blood in a large artery of an anesthetized dog is diverted through a venturimeter. The wider part of the meter has a cross-sectional area equal to that of the artery. i.e.,  $10\text{mm}^2$ . The narrower part has an area  $5\text{mm}^2$ . The pressure drop in the artery is  $22\text{Pa}$ . Density of the blood is  $1.06 \times 10^3 \text{kg m}^{-3}$ . The speed of the blood in the artery is

A.  $0.12\text{ms}^{-1}$

B.  $0.62\text{ms}^{-1}$

C.  $0.24ms^{-1}$

D.  $0.42ms^{-1}$

**Answer: A**



**Watch Video Solution**

50. Dynamic lift due to spinning is a) Magnus effect b) Doppler effect c) Pascal effect d) Torricelli's effect

A. Magnus effect

B. Doppler effect

C. Pascal effect

D. Torricelli's effect

**Answer: A**



**Watch Video Solution**

**51.** With increase in temperature the viscosity of

A. liquids increases and of gases decreases

B. liquids decreases and gases increases

C. both liquids and gases increases

D. both liquids and gases decreases

**Answer: B**



**Watch Video Solution**

**52.** Spherical balls of radius  $R$  are falling in a viscous fluid of velocity  $v$ . The retarding viscous force acting on the spherical ball is

A. directly proportional to  $R$  but inversely proportional  $v$ .

B. directly proportional to both radius  $R$  and velocity  $v$ .

C. inversely proportional to both radius  $R$  and velocity  $v$ .

D. inversely proportional to  $R$  but directly proportional to velocity  $v$ .

**Answer: B**



**Watch Video Solution**

53. When cooking oil is heated in a frying pan, the oil moves around in the pan more easily when it is hot. The main reason for this is that with rise in temperature ,there is a decrease in

A. density

B. surface tension

C. viscosity

D. angle of contact

**Answer: C**



Watch Video Solution

54. The velocity of water in river is  $180 \text{ km h}^{-1}$  near the surface .If the river is 5 m deep, then the shearing stress between the surface layer and the bottom layer is ( coefficient of viscosity of water  $\eta = 10^{-3} \text{ Pa s}$ )

A.  $10^{-2} \text{ Nm}^{-2}$

B.  $10^{-3} \text{ Nm}^{-2}$

C.  $10^{-4} \text{ Nm}^{-2}$



D.  $10^{-5} Nm^{-2}$

**Answer: B**



**Watch Video Solution**

**55.** A metal block of area  $0.10m^2$  is connected to a  $0.01$  kg mass via a string that passes over a massless and frictionless pulley as shown in figure. A liquid with a film thickness of  $0.3$  mm is placed between the block and the table. When released the block moves to the right

with a constant of  $0.085\text{ms}^{-1}$ . The coefficient of viscosity of the liquid is

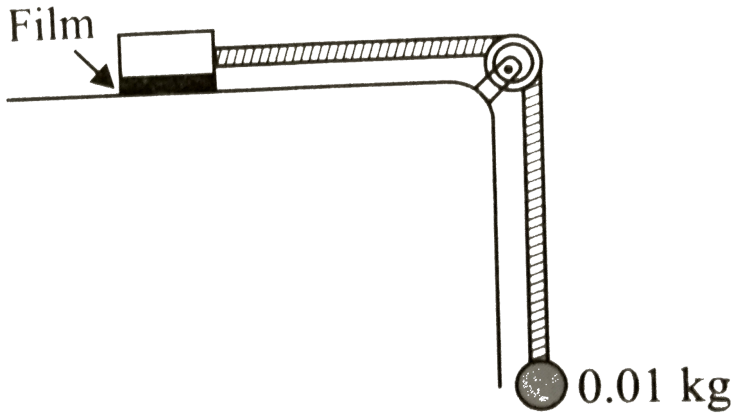

- A.  $2.5 \times 10^{-3}\text{Pa s}$
- B.  $3.5 \times 10^{-3}\text{Pa s}$
- C.  $4.5 \times 10^{-3}\text{Pa s}$
- D.  $6.5 \times 10^{-3}\text{Pa s}$

**Answer: B**



**Watch Video Solution**

**56.** A square plate 0.1 m side moves parallel to second plate with a velocity of  $0.1\text{ms}^{-1}$ , both plate being immersed in water. If the viscous force is 0.002 N and the coefficient of viscosity 0.001 poise, distance between the plate is

A. 0.1 m

B. 0.05 m

C. 0.005 m

D. 0.0005 m

**Answer: D**



**Watch Video Solution**

57. A gas bubble of 2 cm diameter rises through a liquid  $1.75\text{gcm}^{-3}$  with a fixed speed of  $0.35\text{cm s}^{-1}$ . Neglect the density of the gas. The coefficient of viscosity of the liquid is

A. 870 poise

B. 1120 poise

C. 982 poise

D. 1089 poise

**Answer: D**



**Watch Video Solution**

**58.** A rain drop of radius 0.3 mm falls through air with a terminal viscosity of  $1ms^{-1}$ . The

viscosity of air is  $18 \times 10^{-5}$  poise. The viscous force on the rain drop is

A.  $1.018 \times 10^{-2}$  dyne

B.  $2.018 \times 10^{-2}$  dyne

C.  $3.018 \times 10^{-2}$  dyne

D.  $4.018 \times 10^{-2}$  dyne

**Answer: A**



**Watch Video Solution**

59. A solid sphere falls with a terminal velocity  $v$  in air. If it is allowed to fall in vacuum,

A. terminal velocity of sphere =  $v$

B. terminal velocity of sphere  $< v$

C. terminal velocity of sphere  $> v$

D. sphere never attains terminal velocity

**Answer: D**



**Watch Video Solution**

60. After terminal velocity is reached the acceleration of a body falling through a viscous fluid is:

A. zero

B. equal to  $g$

C. less than  $g$

D. more than  $g$

**Answer: A**



**Watch Video Solution**



61. A metallic sphere of mass  $M$  falls through glycerine with a terminal velocity  $v$ . If we drop a ball of mass  $8M$  of same metal into a column of glycerine, the terminal velocity of ball will be

A.  $2v$

B.  $4v$

C.  $8v$

D.  $16v$

**Answer: B**

62. A metal ball  $B_1$  (density  $3.2g/cc$ ) is dropped in water, while another metal ball  $B_2$  (density  $6.0g/cc$ ) is dropped in a liquid of density  $1.6g/cc$ . If both the balls have the same diameter and attain the same terminal velocity, the ratio of viscosity of water to that of the liquid is

A. 2

B. 0.5

C. 4

D. indeterminate due to insufficient data

**Answer: B**



**Watch Video Solution**

**63.** Eight drops of water, each of radius  $2\text{mm}$  are falling through air at a terminal velocity of  $8\text{cm s}^{-1}$ . If they coalesce to form a single drop, then the terminal velocity of combined drop will be

A. 1.  $32\text{cm s}^{-1}$

B. 2.  $30\text{cm s}^{-1}$

C. 3.  $28\text{cm s}^{-1}$

D. 4.  $24\text{cm s}^{-1}$

**Answer: A**



**Watch Video Solution**

**64.** A drop of water of radius  $0.0015\text{ mm}$  is falling in air .If the coefficient of viscosity of air is  $2.0 \times 10^{-5}\text{ kg m}^{-1}\text{ s}^{-1}$  ,the terminal velocity

of the drop will be

(The density of water =  $10^3 \text{kgm}^{-3}$  and  $g = 10 \text{ms}^{-2}$  )

A.  $1.0 \times 10^{-4} \text{ms}^{-1}$

B.  $2.0 \times 10^{-4} \text{ms}^{-1}$

C.  $2.5 \times 10^{-4} \text{ms}^{-1}$

D.  $5.0 \times 10^{-4} \text{ms}^{-1}$

**Answer: C**



**Watch Video Solution**

65. Water is conveyed through a uniform tube of 8 cm in diameter and 3140 m in length at the rate  $2 \times 10^{-3} m^3$  per second. The pressure required to maintain the flow is ( viscosity of water  $= 10^{-3}$  )

A.  $1.625 \times 10^3 Nm^{-2}$

B.  $0.625 Nm^{-2}$

C.  $0.0625 Nm^{-2}$

D.  $0.00625 Nm^{-2}$

**Answer: A**



Watch Video Solution

66. The onset of turbulence in a liquid is determined by

- A. 1. Pascal's law
- B. 2. Reynold's law
- C. 3. Torricell's law
- D. 4. Bernoulli's principle

**Answer: B**



Watch Video Solution

**67.** The ratio of inertial force to viscous force represents

A. Magnus effect

B. Reynolds number

C. Torricell's law

D. Relative density

**Answer: B**



**Watch Video Solution**



68. For turbulent flow, the value of Reynolds number is

A. 1.  $R_e > 2000$

B. 2.  $R_e < 2000$

C. 3.  $1000 < R_e < 2000$

D. 4.  $R_e = 1000$

**Answer: B**



**Watch Video Solution**

69. The flow rate from a tap of diameter  $1.25\text{cm}$  is  $3\text{ L//min}$ . The coefficient of viscosity of water is  $10^{-3}\text{ pa}\cdot\text{s}$ . Characterize the flow.

- A. 1. Unsteady
- B. 2. Turbulent
- C. 3. Laminar
- D. 4. None of above

**Answer: B**



**Watch Video Solution**

70. Which of the following is associated with liquid only and not for gas ?

A. 1. Pressure

B. 2. Volume

C. 3. Density

D. 4. Surface tension

**Answer: D**



**Watch Video Solution**

71. The rain are in spherical shape due to

A. 1. Viscosity

B. 2. surface tension

C. 3. Thrust on drop

D. 4. Both (a) and (b)

**Answer: B**



**Watch Video Solution**

72. Which of the following statements is not true about surface tension ?

A. A small liquid drop takes spherical shape due to surface tension.

B. Surface tension is a vector quantity

C. Surface tension of liquid is a molecular phenomenon

D. Surface tension of liquid depends on length but not on the area

**Answer: B**



**Watch Video Solution**

**73.** For a surface molecule,

A. the net force on it is non zero

B. the net force on it zero

C. there is net downward force

D. there is net upward force

**Answer: C**



Watch Video Solution

74. Mercury does not wet glass. This is the property of liquid known as

- A. Adhesion
- B. Surface tension
- C. Viscosity
- D. Compressibility

**Answer: A**



**75.** A thin liquid film formed between a  $U$  – shaped wire and a light slider supports a weight of  $1.5 \times 10^{-2} N$  (see figure). The length of the slider is  $30\text{cm}$  and its weight negligible.



The surfaces tension of the liquid film is :

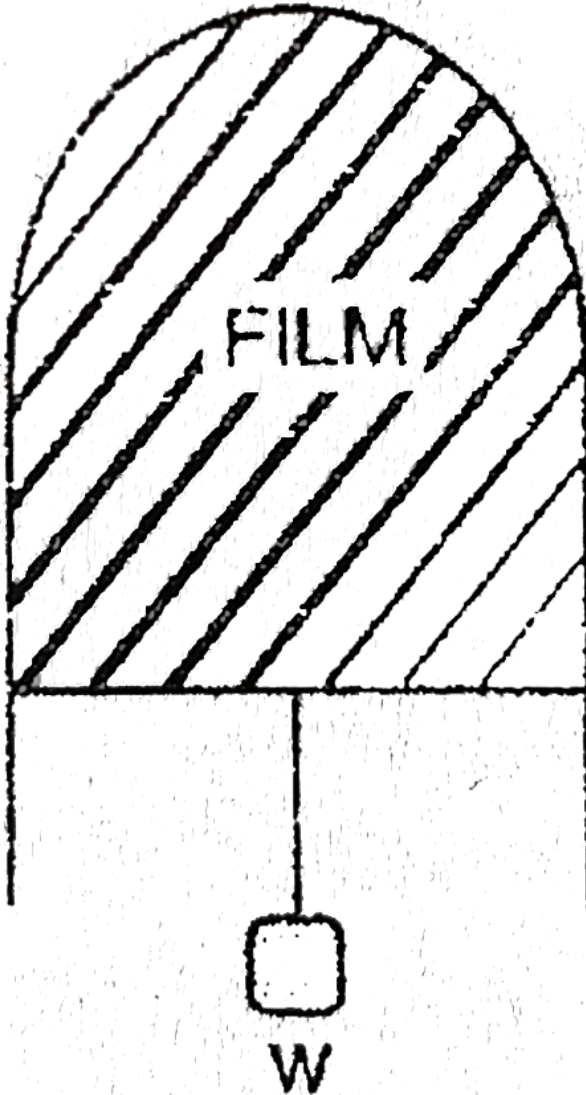

A.  $0.0125Nm^{-1}$

B.  $0.1Nm^{-1}$

C.  $0.05Nm^{-1}$

D.  $0.025Nm^{-1}$

**Answer: D**



**Watch Video Solution**

**76.** Which graph represents the variation of surface tension with temperature over small temperature ranges for water?

A.

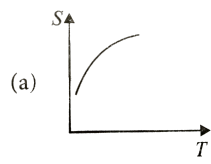

B.

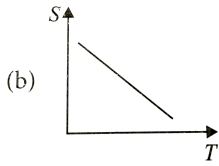

C.

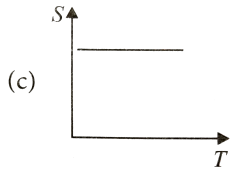

D.

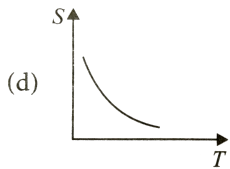

**Answer: B**



**Watch Video Solution**

77. Angle of contact of a liquid with a solid depends on

A. solid only

B. liquid only

C. both on solid and liquid

D. orientation of the solid surface in liquid

**Answer: C**



**Watch Video Solution**

78. Which of the following statements is not true about angle of contact ?

A. The value of contact for pure water and glass is zero

B. Angle of contact increases with increase in temperature of liquid

C. If the angle of contact of a liquid and a solid surface is less than  $90^0$  , then the liquid spreads on the surface of solid

D. Angle of contact doesnot depend upon the inclination of the solid surface to the liquid surface.

**Answer: D**



**Watch Video Solution**

**79.** Which of the following statements is correct ?

A. Viscosity is a vector quantity

B. Surface tension is a vector quantity

C. Reynolds number is a dimensionless quantity

D. Angle of contact is a vector quantity

**Answer: D**



**Watch Video Solution**

**80.** A liquid will not wet the surface of a solid if the angle of contact is

A. zero

B. equal to  $45^\circ$

C. equal to  $90^\circ$

D. greater than  $90^\circ$

**Answer: D**



**Watch Video Solution**

**81.** The soap bubble formed at the end of the tube is blown very slowly. Draw the graph



between excess of pressure inside the bubble  
with time.

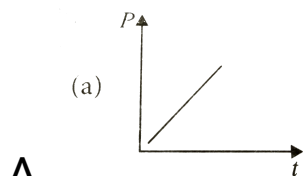

A.

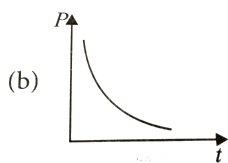

B.

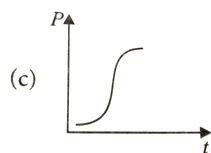

C.

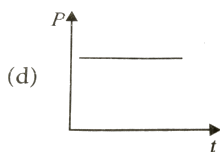

D.

**Answer: B**



**Watch Video Solution**

82. When a drop splits up into number of drops

- A. area increases
- B. volume increases
- C. energy is absorbed
- D. Both (a) and (b)

**Answer: D**



**Watch Video Solution**

**83.** The excess pressure inside a soap bubble is thrice the excess pressure inside a second soap bubble. What is the ratio between the volume of the first and the second bubble?

A. 9 : 1

B. 1 : 3

C. 1 : 9

D. 3 : 1

**Answer: C**



Watch Video Solution

**84.** Work  $W$  is required to form a bubble of volume  $V$  from a given solution. What amount of work is required to be done to form a bubble of volume  $2V$  ?

A.  $4^{2/3}W_1$

B.  $4^{1/3}W_1$

C.  $2^{1/2}W_1$

D.  $2^{3/2}W_1$

**Answer: B**



**Watch Video Solution**

**85.** Find the work done in blowing a soap bubble of surface tension  $0.06Nm^{-1}$  from 2 cm radius to 5 cm radius.

A. 3.1mj

B. 1.25 mj

C. 2.51 mj

D. 4.55 mj

**Answer: A**



**Watch Video Solution**

**86.** The surface tension of soap solution is  $0.03N/m$ . The work done in blowing to from a soap bubble of surface area  $40cm^2$ , (in J), is

A.  $2.4 \times 10^{-4} \text{ J}$

B.  $1.2 \times 10^{-2} \text{ J}$

C.  $3.6 \times 10^{-4} \text{ J}$

D.  $4.2 \times 10^{-2} \text{ J}$

**Answer: A**



**Watch Video Solution**

**87.** Surface tension of mercury is  $0.465Nm^{-1}$ .

The excess pressure inside a mercury drop of diameter 6mm is

A. 310 pa

B. 410 pa

C. 510 pa

D. 610 pa

**Answer: A**



**Watch Video Solution**

**88.** The surface tension of soap solution at a temperature  $20^{\circ}\text{C}$  is  $2.5 \times 10^{-2}\text{Nm}^{-1}$ . The excess pressure inside a bubble of soap solution of radius 6mm is

A. 12.5 pa

B. 14.2 pa

C. 15.5 pa



D. 16.7 pa

**Answer: D**



**Watch Video Solution**

**89.** In question number 88, if an air bubble of the same dimensions were formed at a depth of 30 cm inside a container containing the soap solution of relative density 1.20, then the pressure inside the bubble is ( Take 1 atm =  $1.01 \times 10^5$  Pa)

A.  $1.01 \times 10^4$  Pa

B.  $1.05 \times 10^5$  Pa

C.  $2.01 \times 10^4$  Pa

D.  $3.01 \times 10^4$  Pa

**Answer: B**



**Watch Video Solution**

**90.** The surface tension and vapour pressure of water at  $20^\circ\text{C}$  is  $7.28 \times 10^{-2} \text{Nm}^{-1}$  and  $2.33 \times 10^3$  Pa respectively. The radius of the

smallest spherical water droplet which can form without evaporating at  $25^{\circ}\text{C}$  is

A.  $1.25 \times 10^{-5} \text{ m}$

B.  $6.25 \times 10^{-5} \text{ m}$

C.  $4.3 \times 10^8 \text{ m}$

D.  $3.4 \times 10^3 \text{ m}$

**Answer: B**



**Watch Video Solution**

91. When a capillary tube is dipped in a liquid, the liquid rises to a height  $H$  in the tube. The free liquid surface inside the tube is hemispherical in shape. The tube is now pushed down so that the height of the tube outside the liquid is less than  $H$ . Then the

- A. liquid will come out of the tube like in a small fountain
- B. liquid will ooze out of the tube slowly

C. free liquid surface inside the tube is hemispherical

D. the liquid will fill the tube but not come out its upper end.

**Answer: D**



**Watch Video Solution**

**92.** A capillary tube is taken from the Earth to the surface of the moon. The rise of the liquid column on the Moon (acceleration due to

gravity on the Earth is 6 times that of the Moon) is

- A. six times that on the earth's surface
- B.  $\frac{1}{6}$  that on the earth surface
- C. equal on that of the earth surface
- D. zero

**Answer: A**



**Watch Video Solution**

93. A capillary tube (A) is dipped in water. Another identical tube (B) is dipped in a soap-water solution. Which of the following shows the relative nature of the liquid columns in the two tubes?

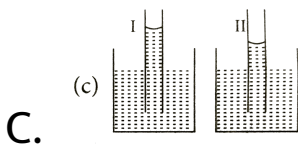
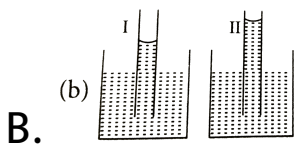
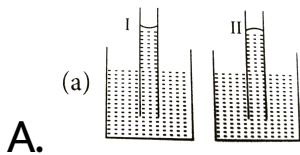

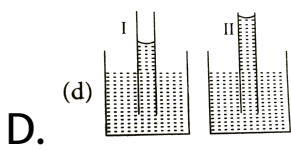

**Answer: C**



**Watch Video Solution**

**94.** The radii of the two columns in U-tube are  $r_1$  and  $r_2$  ( $> r_1$ ). When a liquid of density  $\rho$  (angle of contact is  $0^\circ$ ) is filled in it, the level difference of liquid in two arms is  $h$ . The surface tension of liquid is

( $g =$  acceleration due to gravity)



A.  $\frac{\rho g h r_1 r_2}{2(r_2 - r_1)}$

B.  $\frac{\rho g h (r_1 - r_2)}{2r_1 r_2}$

C.  $\frac{2(r_2 - r_1)}{\rho g h r_1 r_2}$

D.  $\frac{\rho g h}{2(r_2 - r_1)}$

**Answer: A**



**Watch Video Solution**

**95.** The sap in tree rises in a system of capillaries of radius  $2.5 \times 10^{-2}m$ . The surface tension of the sap is  $7.28 \times 10^{-2}Nm^{-1}$  and

the angle of contact is  $0^\circ$ . The maximum height to which sap can rise in tree through capillarity action is ( $\rho_{\text{sap}} = 10^3 \text{kgm}^{-3}$ )

A. 0.21 m

B. 0.59 m

C. 0.87 m

D. 0.91 m

**Answer: B**



**Watch Video Solution**

**96.** Mercury has an angle of contact equal to  $140^\circ$  with soda lime glass. A narrow tube of radius  $1.00\text{mm}$  made of this glass is dipped in a trough containing mercury. By what amount does the mercury dip down in the tube relative to the mercury surface outside? Surface tension of mercury at the temperature of the experiment is  $0.465\text{Nm}^{-1}$ . Density of mercury =  $13.6 \times 10^3\text{kgm}^{-3}$ .

A. 5.34 mm

B. 2.35 mm

C. 6.25 mm

D. 1.44 mm

**Answer: A**



**Watch Video Solution**

**97.** Two capillaries of same length and radii in the ratio 1 : 2 are connected in series. A liquid flows through them in streamlined condition. If the pressure across the two extreme ends of

the combination is 1 m of water, the pressure difference across first capillary is

A. 9.4 m

B. 4.9 m

C. 0.49 m

D. 0.94 m

**Answer: D**



**Watch Video Solution**

98. If the surface tension of water is  $0.06 \text{ N/m}$ , then the capillary rise in a tube of diameter  $1 \text{ mm}$  is ( $\theta = 0^\circ$ )

A.  $1.22 \text{ cm}$

B.  $2.44 \text{ cm}$

C.  $3.12 \text{ cm}$

D.  $3.86 \text{ cm}$

**Answer: B**



**Watch Video Solution**

99. The rise in the water level in a capillary tube of radius 0.07 cm when dipped vertically in a beaker containing water of surface tension  $0.07 \text{ Nm}^{-1}$  is ( $g = 10 \text{ ms}^{-2}$ )

A. 2 cm

B. 4 cm

C. 1.5 cm

D. 3 cm

**Answer: A**



**Watch Video Solution**

**100.** A capillary tube of radius  $r$  is immersed in water and water rises in to a height  $h$ . The mass of water in the capillary tube is 5g. Another capillary tube of radius  $2r$  is immersed in water. The mass of water that will rise in this tube is

A. 2.5 g

B. 5.0 g

C. 10 g



D. 20 g

**Answer: C**



**Watch Video Solution**

## Higher Order Thinking Skills

1. A glass capillary tube is of the shape of a truncated cone with an apex angle  $\alpha$  so that its two ends have cross sections of different radii. When dipped in water vertically, water

rises in it to a high  $h$ , where the radius of its cross section is  $b$ . If the surface tension of water is  $S$ , its density is  $\rho$ , and its contact angle with glass is  $\theta$ , the value of  $h$  will be ( $g$  is the acceleration due to gravity)

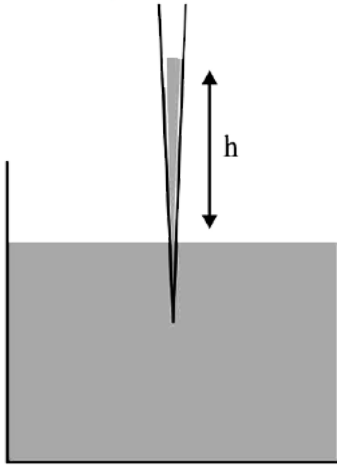

- A.  $\frac{2S}{b\rho g} \cos(\theta - \alpha)$   
 B.  $\frac{2S}{b\rho g} \cos(\theta + \alpha)$

C.  $\frac{2S}{b\rho g} \cos(\theta - \alpha/2)$

D.  $\frac{2S}{b\rho g} \cos(\theta + \alpha)$

**Answer: D**



**Watch Video Solution**

2. A uniform cylinder of length  $L$  and mass  $M$  having cross-sectional area  $A$  is suspended, with its length vertical, from a fixed point by a massless spring such that it is half submerged in a liquid of density  $\sigma$  at equilibrium position.

The extension  $x_0$  of the spring when it is in equilibrium is:

A.  $\frac{Mg}{k} \left( 1 + \frac{La\sigma}{M} \right)$

B.  $\frac{Mg}{k}$

C.  $\frac{Mg}{k} \left( 1 + \frac{La\sigma}{M} \right)$

D.  $\frac{Mg}{k} \left( 1 - \frac{La\sigma}{2M} \right)$

**Answer: D**



**Watch Video Solution**

3. A tiny spherical oil drop carrying a net charge  $q$  is balanced in still air with a vertical uniform electric field of strength  $\frac{81\pi}{7} \times 10^5 \text{Vm}^{-1}$ . When the field is switched off, the drop is observed to fall with terminal velocity  $2 \times 10^{-3} \text{ms}^{-1}$ . Given  $g = 9.8 \text{ms}^{-2}$ , viscoisty of the air  $= 1.8 \times 10^{-5} \text{Nsm}^{-2}$  and the denisty of oil  $= 900 \text{kgm}^{-3}$ , the magnitude of  $q$  is

A.  $1.6 \times 10^{-19} \text{ C}$

B.  $3.2 \times 10^{-19} \text{ C}$

C.  $4.8 \times 10^{-19} \text{ C}$

D.  $8.0 \times 10^{-19} \text{ C}$

**Answer: D**



**Watch Video Solution**

4. A bubble having surface tension  $T$  and radius  $R$  is formed on a ring of radius  $b$  ( $b < R$ ). Air is blown inside the tube with velocity  $v$  as shown. The air molecule collides perpendicularly with the wall of the bubble

and stops. Calculate the radius at which the bubble separates from the ring.

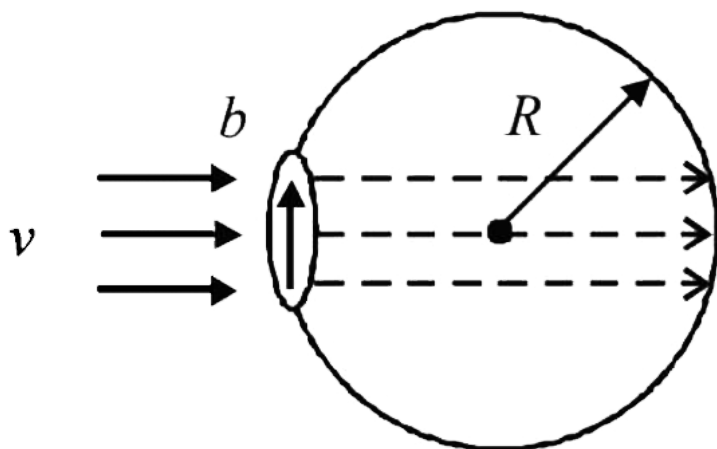

A. 1.  $\frac{2T}{\rho v^2}$

B. 2.  $\frac{2T}{\rho v}$

C. 3.  $\frac{4T}{\rho v^2}$

D. 4.  $\frac{4T}{\rho v}$

**Answer: C**



**Watch Video Solution**

5. A vessel contains two immiscible liquids of density  $\rho_1 = 1000\text{kg}/\text{m}^3$  and  $\rho_2 = 1500\text{kg}/\text{m}^3$ . A solid block of volume  $V = 10^3\text{m}^3$  and density  $d = 800\text{kg}/\text{m}^3$  is tied to one end of a string and the other end is tied to the bottom of the vessel as shown in figure.

The block is immersed with two fifths of its



volume in the liquid of lower density. The entire system is kept in an elevator which is moving upwards with an acceleration of  $a = \frac{g}{2}$ . Find the tension in the string.

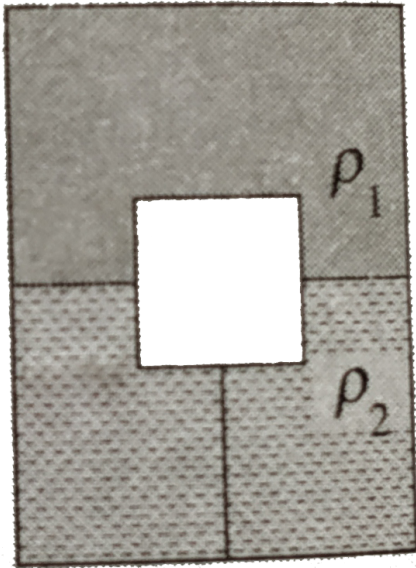

A. 1.8N

B. 2.6N

C. 3. 10N

D. 4. 12N

**Answer: B**



**Watch Video Solution**

6. A glass tube in the form of an equilateral triangle of uniform cross-section is as shown in figure. It lies in the vertical plane, with base horizontal. The tube is filled with equal volumes of three immiscible liquids whose

densities are in arithmetic progression.

Determine the length  $x$  as shown in figure

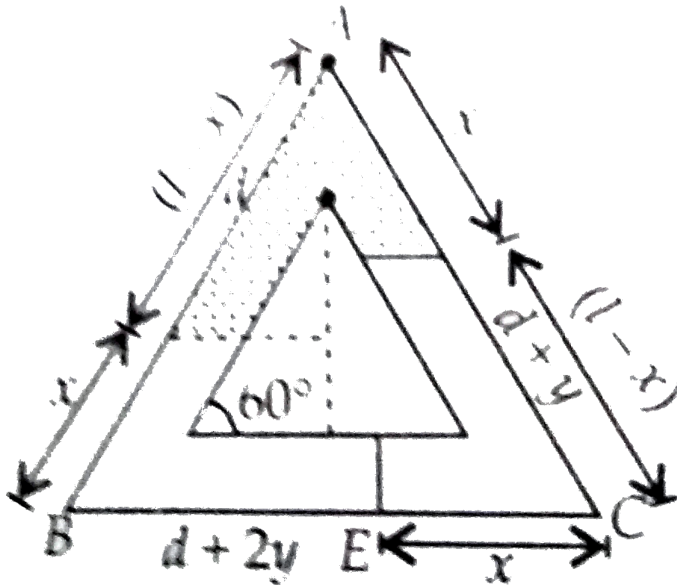

A.  $3l$

B.  $2l$

C.  $l/3$

D.  $l/2$

**Answer: C**



**Watch Video Solution**

7. Two soap bubbles  $A$  and  $B$  are kept in a closed chamber where the air is maintained at pressure  $8N/m^2$ . The radii of bubbles  $A$  and  $B$  are  $2cm$  and  $4cm$ , respectively. Surface tension of the soap. Water used to make bubbles is  $0.04N/m$ . Find the ratio  $n_B/n_A$ , where  $n_A$  and  $n_B$  are the number of moles of

air in bubbles  $A$  and  $B$  respectively. [Neglect the effect of gravity.]

A. 2

B. 4

C. 6

D. 8

**Answer: C**



**Watch Video Solution**

8. A cylindrical vessel of height 500mm has an orifice (small hole) at its bottom. The orifice is initially closed and water is filled in it up to height H. Now the top is completely sealed with a cap and the orifice at the bottom is opened. Some water comes out from the orifice and the water level in the vessel becomes steady with height of water column being 200mm. Find the fall in height(in mm) of water level due to opening of the orifice.

[Take atmospheric pressure

$= 1.0 \times 10^5 N/m^2$ , density of

water= $1000\text{kg}/\text{m}^3$  and  $g=10\text{m}/\text{s}^2$ . Neglect any effect of surface tension.]

A. 6

B. 4

C. 2

D. 8

**Answer: A**



**Watch Video Solution**

1. A tall cylinder is filled with viscous oil. A round pebble is dropped from the top with zero initial velocity. From the plot shown in figure, indicate the one that represents the velocity ( $v$ ) of the pebble as a function of time ( $t$ )

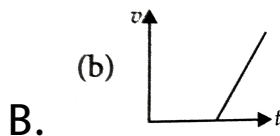
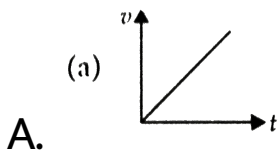



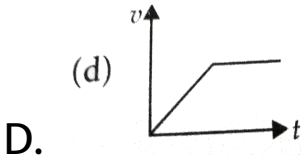
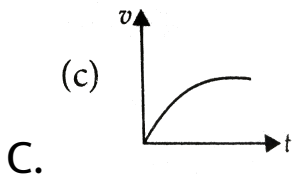

**Answer: C**



**Watch Video Solution**

2. Which of the following diagrams does not represent a streamline flow?

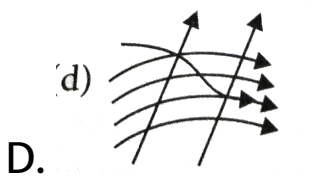
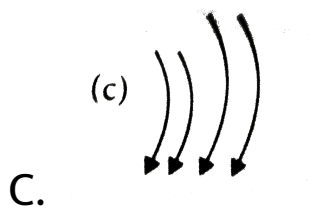
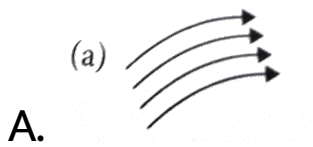

**Answer: D**



**View Text Solution**

3. Along a streamline,

A. the velocity of a fluid particle remains constant

B. the velocity of all fluid particles crossing a given position is constant

C. the velocity of all fluid particles at a given instant is constant

D. the speed of a fluid particle remains constant

**Answer: B**



**View Text Solution**

4. An ideal fluid flows through a pipe of circular cross-section made of two sections with diameters  $2.5\text{cm}$  and  $3.75\text{cm}$ . The ratio of the velocities in the two pipes is

A.  $9:4$

B.  $3:2$

C.  $\sqrt{3}:\sqrt{2}$

D.  $\sqrt{2} : \sqrt{3}$

**Answer: A**



**Watch Video Solution**

5. The angle of contact at the interface of water glass is  $0^\circ$  ethylalcohol-glass is  $0^\circ$  mercury glass is  $140^\circ$  and methyliodide-glass is  $30^\circ$  A glass capillary is put in a trough containing one of these four liquids. It is

observed that the meniscus is convex. The liquid in the through is

A. water

B. ethylalcohol

C. mercury

D. methyl iodide

**Answer: C**



**Watch Video Solution**

1. Assertion: If an object is submerged in fluid at rest, the fluid exerts a force on its surface.

Reason: The force exerted by the fluid at rest has to be parallel to the surface in contact with it.

A. Both assertion and reason are true and reason is the correct explanation of assertion.

B. Both assertion and reason are true but reason is not the correct explanation of

assertion.

C. Assertion is true and reason is false.

D. Both assertion and reason are false.

**Answer: C**



**Watch Video Solution**

2. Assertion: Liquids and gases are largely incompressible and densities are therefore, nearly constant at all pressure.



Reason: Liquids exhibit a large variation in densities with pressure by gases do not.

A. If both assertion and reason are true and reason is the correct explanation of assertion.

B. If both assertion and reason are true but reason is not the correct explanation of assertion.

C. If assertion is true and reason is false.

D. If both assertion and reason are false.

**Answer: D**



**Watch Video Solution**

**3. Assertion:** Pascal law is the working principle of hydraulic lift.

**Reason:** Pressure =  $\frac{\textit{thrust}}{\textit{area}}$

A. Both assertion and reason are true and reason is the correct explanation of assertion.

B. Both assertion and reason are true but reason is not the correct explanation of assertion.

C. Assertion is true and reason is false.

D. Both assertion and reason are false.

**Answer: B**



**Watch Video Solution**

4. Assertion: An open-tube manometer is a useful instrument for measuring pressure differences.

Reason:  $1 \text{ bar} = 10^5 \text{ Pa}$ .

A. Both assertion and reason are true and reason is the correct explanation of assertion.

B. Both assertion and reason are true but reason is not the correct explanation of assertion.

C. Assertion is true and reason is false.

D. Both assertion and reason are false.

**Answer: B**



**Watch Video Solution**

5. Statement I: A needle placed carefully on the surface of water may float, whereas the ball of the same material will always sink.

Statement II: The buoyancy of an object

depends both on the material and shape of the object.

A. If both assertion and reason are true and reason is the correct explanation of assertion.

B. If both assertion and reason are true but reason is not the correct explanation of assertion.

C. If assertion is true and reason is false.

D. If both assertion and reason are false.

**Answer: C**



**Watch Video Solution**

**6. Assertion:** The flow of fluid is said to be steady if at any given point, the velocity of each passing fluid particle remains constant.

**Reason:** The path taken by a fluid particle under a steady flow is a streamline.

A. If both assertion and reason are true and reason is the correct explanation of

assertion.

B. If both assertion and reason are true but reason is not the correct explanation of assertion.

C. If assertion is true and reason is false.

D. If both assertion and reason are false.

**Answer: B**



**Watch Video Solution**



7. Assertion: Aeroplanes are made to run on the runway before take off, so that they acquire the necessary lift.

Reason: This is as per Bernoulli's theorem.

A. If both assertion and reason are true and reason is the correct explanation of assertion.

B. If both assertion and reason are true but reason is not the correct explanation of assertion.

C. If assertion is true and reason is false.

D. If both assertion and reason are false.

**Answer: A**



**Watch Video Solution**

**8.** Assertion: Bernoulli's equation hold for non-steady or turbulent flows.

Reason: In these situations, velocity and pressure are constant with time.

A. If both assertion and reason are true and reason is the correct explanation of assertion.

B. If both assertion and reason are true but reason is not the correct explanation of assertion.

C. If assertion is true and reason is false.

D. If both assertion and reason are false.

**Answer: D**



**Watch Video Solution**

**9. Assertion:** The viscosity of water is less than blood.

**Reason :** The viscosity of liquids decreases with increases in temperature.

A. If both assertion and reason are true and reason is the correct explanation of assertion.

B. If both assertion and reason are true but reason is not the correct explanation of

assertion.

C. If assertion is true and reason is false.

D. If both assertion and reason are false.

**Answer: B**



**Watch Video Solution**

**10.** Assertion :when fluid flows, there is some loss of energy due to friction.

Reason : Different layers of the fluid exert forces on each other .

A. If both assertion and reason are true and reason is the correct explanation of assertion.

B. If both assertion and reason are true but reason is not the correct explanation of assertion.

C. If assertion is true and reason is false.

D. If both assertion and reason are false.

**Answer: A**



**Watch Video Solution**

**11.** Assertion: The flow is turbulent for Reynolds number greater than 2000

Reason: Turbulence dissipates kinetic energy in the form of heat.

A. If both assertion and reason are true and reason is the correct explanation of assertion.

B. If both assertion and reason are true but reason is not the correct explanation of

assertion.

C. If assertion is true and reason is false.

D. If both assertion and reason are false.

**Answer: B**



**Watch Video Solution**

**12. Assertion :** The angle of contact of a liquid with a solid decreases with increase in temperature.



Reason : With increase in temperature, the surface tension of the liquid increases.

A. If both assertion and reason are true and reason is the correct explanation of assertion.

B. If both assertion and reason are true but reason is not the correct explanation of assertion.

C. If assertion is true and reason is false.

D. If both assertion and reason are false.

**Answer: C**



**Watch Video Solution**

**13. Assertion :**The contact angle between water and glass is acute.

**Reason :**The surface of water in the capillary is convex .

A. If both assertion and reason are true and reason is the correct explanation of assertion.

B. If both assertion and reason are true but reason is not the correct explanation of assertion.

C. If assertion is true and reason is false.

D. If both assertion and reason are false.

**Answer: C**



**Watch Video Solution**

**14.** Assertion. A bubble comes from the bottom of a lake to the top.

Reason. Its radius increases.

A. If both assertion and reason are true and reason is the correct explanation of assertion.

B. If both assertion and reason are true but reason is not the correct explanation of assertion.

C. If assertion is true and reason is false.

D. If both assertion and reason are false.

**Answer: B**



**Watch Video Solution**

**15. Assertion :**When height of a tube is less than liquid rise in the capillary tube, the liquid does not overflow.

**Reason :** Product of radius of meniscus and height of liquid in the capillary tube always remains constant.

A. If both assertion and reason are true and reason is the correct explanation of assertion.

B. If both assertion and reason are true but reason is not the correct explanation of assertion.

C. If assertion is true and reason is false.

D. If both assertion and reason are false.

**Answer: A**



**Watch Video Solution**

## Pressure

1. Pressure applied to an enclosed fluid is transmitted undiminished to every portion of the fluid and the walls of the containing vessel. This law was first formulated by

A. Reynolds

B. Bernoulli

C. Pascal

D. Torricelli

**Answer: C**



**Watch Video Solution**

2. Which of the following conversions is correct ?

A.  $1 \text{ atm} = 1.01 \times 10^4 \text{ Pa}$

B.  $1 \text{ mm of Hg} = 133 \text{ Pa}$

C.  $1 \text{ bar} = 10^7 \text{ Pa}$



D.  $1 \text{ torr} = 10^2 \text{ Pa}$

**Answer: B**



**Watch Video Solution**

**3. Pressure is a scalar quantity, because**

A. it is the ratio of force to area and both

force and area are vectors.

B. it is the ratio of the magnitude of the

force to area

C. it is the ratio of the component of the force normal to the area

D. it depends on the size of the area chosen.

**Answer: C**



**Watch Video Solution**

**4. Pressure at a point inside a liquid does not depend on**

A. the nature of the liquid

B. shape of the container

C. the depth of point below the surface of  
the liquid

D. acceleration due to gravity at that point

**Answer: B**



**Watch Video Solution**

5. The two femurs each of cross-sectional area  $10\text{cm}^2$  support the upper part of a human body of mass 40 kg. the average pressure sustained by the femurs is (take  $g = 10\text{ms}^{-2}$ )

A.  $2 \times 10^2 \text{Nm}^{-2}$

B.  $2 \times 10^4 \text{Nm}^{-2}$

C.  $2 \times 10^5 \text{Nm}^{-2}$

D.  $2 \times 10^6 \text{Nm}^{-2}$

**Answer: C**



Watch Video Solution

6. A 50 kg girl wearing heel shoes balances on a single heel. The heel is circular with a diameter 1 cm. The pressure exerted by the heel on the horizontal floor is  
(Take  $g = 10 \text{ ms}^{-2}$ )

A.  $6.4 \times 10^4 \text{ Pa}$

B.  $6.4 \times 10^5 \text{ Pa}$

C.  $6.4 \times 10^6 \text{ Pa}$

D.  $6.4 \times 10^7 \text{ Pa}$

**Answer: C**



**Watch Video Solution**

7. Two syringes of different cross-section (without needle filled with water are connected with a tightly fitted rubber tube filled with water. Diameters of the smaller piston and larger piston are  $1\text{cm}$  and  $3\text{cm}$  respectively. If a force of  $10\text{N}$  is applied to the smaller piston then the force exerted on the larger piston is

A. 30N

B. 60 N

C. 90 N

D. 100 N

**Answer: C**



**Watch Video Solution**

**8.** In the previous question if the smaller piston is pushed in through  $6\text{cm}$ , how much does the longer piston move out?

A.  $\frac{2}{3}$  cm

B.  $\frac{3}{2}$  cm

C.  $\frac{1}{3}$  cm

D.  $\frac{1}{2}$  cm

**Answer: A**



**View Text Solution**

9. To what height should a cylindrical vessel be filled with a homogeneous liquid to make the force with which the liquid pressure on



the sides of the vessel equal to the force exerted by the liquid on the bottom of the vessel ?

A. equal to the radius

B. less than radius

C. more than radius

D. four times of radius

**Answer: A**



**Watch Video Solution**

10. A U tube contains water and methylated spirit separated by mercury. The mercury columns in the two arms are at the same level with 10 cm of water in one arm and 12.5 cm of spirit in the other as shown in figure. The relative density of the spirit is

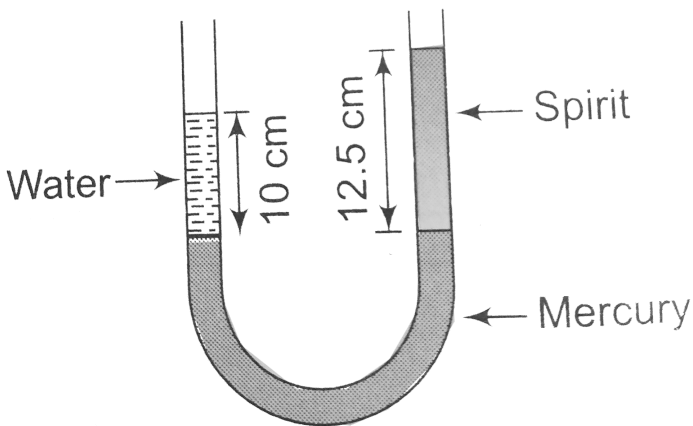

A. 0.6

B. 0.8

C. 1

D. 1.25

**Answer: B**



**Watch Video Solution**

**11.** in previous question, if 15 cm of water and spirit each are further poured into the respective arms of the tube. Difference in the

level of mercury in the two arms is (Take, relative density of mercury = 13.6)

A. 0.20 cm

B. 0.22 cm

C. 0.27 cm

D. 0.26 cm

**Answer: B**



**View Text Solution**

12. In a wind tunnel experiment the pressure on the upper and lower surfaces of the wings are  $0.90 \times 10^5$  Pa and  $0.91 \times 10^5$  Pa respectively .If the area of the wings is  $40m^2$  the net liftng forcw on the wing is

A.  $2 \times 10^4$  N

B.  $4 \times 10^4$  N

C.  $6 \times 10^4$  N

D.  $8 \times 10^4$  N

**Answer: B**



Watch Video Solution

13. Three vessels A,B,and C of different shapes contain a water upto the same height as shown in the figure . $P_A$ ,  $P_B$  ,and  $P_C$  be the pressure exerted by the water at the bottom of the vessels A ,B and C respectively . Then

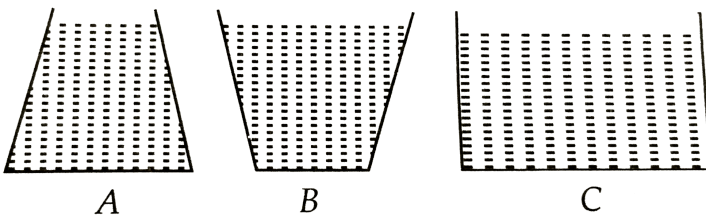

A.  $P_A > P_B > P_C$

B.  $P_B > P_C > P_A$

C.  $P_C > P_B > P_A$

D.  $P_A = P_B = P_C$

**Answer: D**



**Watch Video Solution**

**14.** Which of the following instrument is used to measure gauge pressure ?

A. Thermometer

B. Barometer

C. Manometer

D. Hydrometer

**Answer: C**



**Watch Video Solution**

**15.** A manometer reads the pressure of a gas in an enclosure as shown in the figure. The absolute and gauge pressure of the gas in cm



of mercury is (take atmospheric pressure =76  
cm of mercury)

A. 76,20

B. 20,76

C. 96,20

D. 20,96

**Answer: C**



**View Text Solution**

**16.** The pressure at depth  $h$  below the surface of a liquid of density  $\rho$  open to the atmosphere is

A. greater than the atmospheric pressure

by  $\rho gh$

B. less than the atmospheric pressure by

$\rho gh$

C. equal to the atmospheric pressure

D. increases exponentially with depth

**Answer: A**



**Watch Video Solution**

**17.** The force acting on a window of area  $50 \times 50$  cm<sup>2</sup> of a submarine at a depth of 2000 m in an ocean, the interior of which is maintained at sea level atmospheric pressure is (density of sea water =  $10^3 \text{ kg m}^{-3}$ ,  $g = 10 \text{ m s}^{-2}$ )

A.  $5 \times 10^5 \text{ N}$

B.  $25 \times 10^5 \text{ N}$

C.  $5 \times 10^6 \text{N}$

D.  $25 \times 10^6 \text{N}$

**Answer: C**



**Watch Video Solution**

**18.** A tank with a square base of area  $2\text{m}^2$  is divided into two compartments by a vertical partition in the middle. There is a small hinged door of face area  $20\text{cm}^2$  at the bottom of the partition. Water is filled in one compartment

and an acid of relative density 1.5 in the other, both to a height of 4m. The force necessary to keep the door closed is ( $Takeg = 10ms^{-2}$ )

A. 10N

B. 20 N

C. 40 N

D. 80 N

**Answer: C**



**View Text Solution**

19. Some iron beads are embedded in wax ball which is just floating in water. The volume of ball is  $18 \text{ cm}^3$  and relative density of wax is 0.9. Then mass of the iron trapped in the ball is

A. 1.8 g

B. 2.7 g

C. 16.8 g

D. 8.1 g

**Answer: A**



**View Text Solution**

20. Hydraulic brakes are based on

- A. Pascal's law
- B. Torricelli's law
- C. Newton's law
- D. Boyle's law

**Answer: A**



**Watch Video Solution**

21. A piece of solid weighs 120 g in air ,80 g in water and 60 kg in a liquid . The relative density of the solid and that of the liquid are respectively

A. 2,  $\frac{1}{2}$

B. 2,  $\frac{3}{2}$

C. 3,  $\frac{1}{2}$

D. 3,  $\frac{3}{2}$

**Answer: D**



**Watch Video Solution**



22. A block of wood floats in water with  $(4/5)th$  of its volume submerged. If the same block just floats in a liquid, the density of liquid in  $(kgm^{-3})$  is

A. 1250

B. 600

C. 400

D. 800

**Answer: D**



Watch Video Solution

23. Iceberg floats in sea water with a part of it submerged. The percentage fraction of the ice berg not submerged is (density of ice =  $0.9gcm^{-3}$ , density of sea water =  $1.1gcm^{-3}$ )

A. 18 %

B. 12 %

C. 10 %

D. 8 %

**Answer: A**



**Watch Video Solution**

**24.** A body of mass 100 kg and density  $500 \text{ kg m}^{-3}$  floats in water. The additional mass should be added to the body so that the body will sink is

A. 80 kg

B. 100 kg

C. 150 kg

D. 200 kg

**Answer: B**



**Watch Video Solution**

**25.** A man is sitting in a boat which is floating in a pond. If the man drinks some water from the pond, the level of water in the pond

A. increases

B. decreases

C. remain unchanged

D. increases or decreases depends upon  
the weight of man

**Answer: C**



**Watch Video Solution**

**26.** An ice block having two similar metallic pieces is floating in water in a vessel as shown in figure. After sometimes the ice melts

completely then

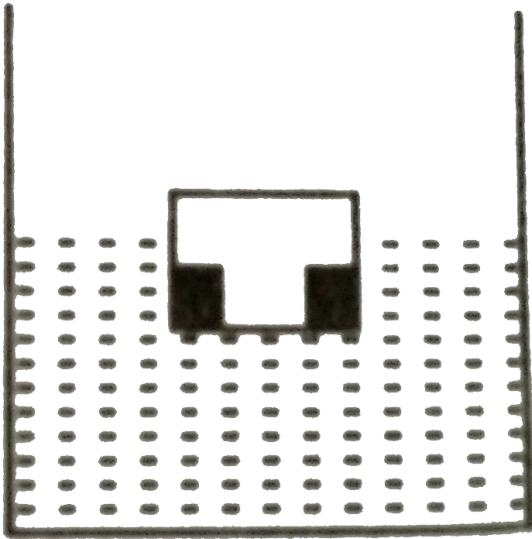

- A. the water level rises in water
- B. the water level falls in the vessel
- C. the water level does not change in vessel

D. the water level may rise or fall

depending upon the ratio of masses of

ice and metallic pieces

**Answer: B**



**Watch Video Solution**

27. An adulterated sample of milk has a density

$1032 \text{kgm}^{-3}$ , while pure milk has a density of

$1080 \text{kgm}^{-3}$ . Then the volume of pure milk in

a sample of 10 litres of adulterated milk is

A. 1 litre

B. 2 litre

C. 3 litre

D. 4 litre

**Answer: D**



**Watch Video Solution**

**28.** A body is just floating on the surface of a liquid. The density of the body is the same as



that of the liquid. The body is slightly pushed down. What will happen to the body?

- A. come back slowly to its earlier position
- B. remain submerged where it is left
- C. sink in liquid
- D. come out vigoursly

**Answer: C**



**Watch Video Solution**

1. Streamline flow is more likely for liquid with

A. 1. high density and high viscosity

B. 2. low density and low viscosity

C. 3. high density and low viscosity

D. 4. low density and high viscosity

**Answer: D**



**Watch Video Solution**

2. When the flow parameters of any given instant remain same at every point, then flow is said to be

- A. 1. laminar
- B. 2. steady state
- C. 3. turbulent
- D. 4. quasistatic

**Answer: B**



**Watch Video Solution**

3. An ideal flow of any fluid must satisfy

A. 1. Pascal law

B. 2. Stokes' law

C. 3. Continuity equation

D. 4. Bernoulli's theorem

**Answer: C**



**Watch Video Solution**

4. Water is flowing continuously from a tap having an internal diameter  $8 \times 10^{-3} \text{m}$ . The water velocity as it leaves the tap is  $0.4 \text{ms}^{-1}$ . The diameter of the water stream at a distance  $2 \times 10^{-1} \text{m}$  below the tap is close to ( $g = 10 \text{m} / \text{s}^2$ )

A.  $5.0 \times 10^{-3} \text{m}$

B.  $7.5 \times 10^{-3} \text{m}$

C.  $9.6 \times 10^{-3} \text{m}$

D.  $3.6 \times 10^{-3} \text{m}$

Answer: D



Watch Video Solution

5. In the figure, an ideal liquid flows through the tube, which is of uniform cross section. The liquid has velocities  $v_A$  and  $v_B$ , and pressures  $P_A$  and  $P_B$  at the points  $A$  and  $B$ , respectively. Then

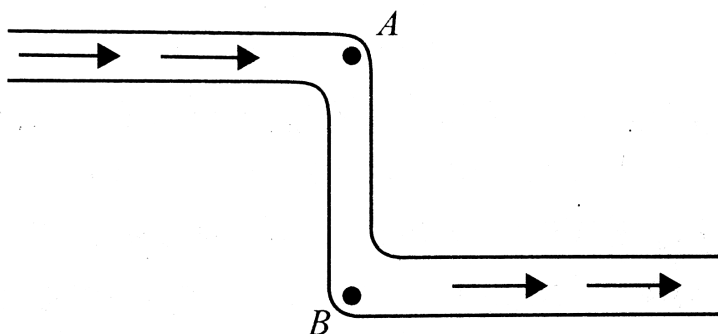

A.  $v_B > v_A$

B.  $v_B = v_A$

C.  $P_B < P_A$

D.  $P_B = P_A$

**Answer: B**



**Watch Video Solution**

6. An ideal fluid flows through a pipe of circular cross-section made of two sections

with diameters  $2.5\text{cm}$  and  $3.75\text{cm}$ . The ratio of the velocities in the two pipes is

A.  $9:4$

B.  $3:2$

C.  $\sqrt{3}:\sqrt{2}$

D.  $\sqrt{2}:\sqrt{3}$

**Answer: A**



**Watch Video Solution**



7. The cylindrical tube of a spray pump has a cross-section of  $6\text{cm}^2$  one of which has 50 holes each of diameter 1 mm. If the liquid flow inside the tube is 1.2 m per minutes, then the speed of ejection of the liquid through the holes is

A.  $1.21\text{ms}^{-1}$

B.  $0.31\text{ms}^{-1}$

C.  $0.96\text{ms}^{-1}$

D.  $3.4\text{ms}^{-1}$

**Answer: B**



**View Text Solution**

## Viscosity

1. With increase in temperature the viscosity of
- A. liquids increases and of gases decreases
  - B. liquids decreases and gases increases
  - C. both liquids and gases increases

D. both liquids and gases decreases

**Answer: B**



**Watch Video Solution**

2. Spherical balls of radius  $R$  are falling in a viscous fluid of velocity  $v$ . The retarding viscous force acting on the spherical ball is

A. directly proportional to  $R$  but inversely proportional  $v$ .

B. directly proportional to both radius  $R$   
and velocity  $v$ .

C. inversely proportional to both radius  $R$   
and velocity  $v$ .

D. inversely proportional to  $R$  but directly  
proportional to velocity  $v$ .

**Answer: B**



**Watch Video Solution**

3. When cooking oil is heated in a frying pan, the oil moves around in the pan more easily when it is hot. The main reason for this is that with rise in temperature ,there is a decrease in

A. density

B. surface tension

C. viscosity

D. angle of contact

**Answer: C**



Watch Video Solution

4. The velocity of water in river is  $180 \text{ km h}^{-1}$  near the surface .If the river is 5 m deep,then the shearing stress between the surface layer and the bottom layer is ( coefficient of viscosity of water  $\eta = 10^{-3} \text{ Pa s}$ )

A.  $10^{-2} \text{ Nm}^{-2}$

B.  $10^{-3} \text{ Nm}^{-2}$

C.  $10^{-4} \text{ Nm}^{-2}$

D.  $10^{-5} \text{ Nm}^{-2}$

**Answer: B**



**Watch Video Solution**

5. A metal block of area  $0.10\text{m}^2$  is connected to a  $0.01\text{ kg}$  mass via a string that passes over a massless and frictionless pulley as shown in figure. A liquid with a film thickness of  $0.3\text{ mm}$  is placed between the block and the table. When released the block moves to the right with a constant of  $0.085\text{m.s}^{-1}$ . The coefficient

of viscosity of the liquid is

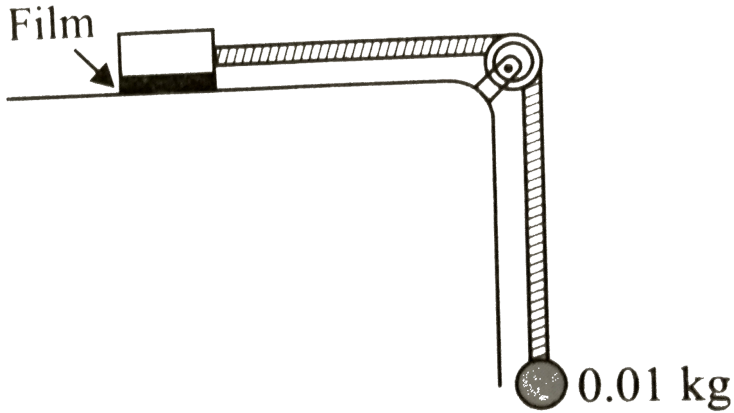

A.  $2.5 \times 10^{-3} \text{ Pa s}$

B.  $3.5 \times 10^{-3} \text{ Pa s}$

C.  $4.5 \times 10^{-3} \text{ Pa s}$

D.  $6.5 \times 10^{-3} \text{ Pa s}$

**Answer: B**





Watch Video Solution

6. A square plate 0.1 m side moves parallel to second plate with a velocity of  $0.1\text{ms}^{-1}$ , both plate being immersed in water. If the viscous force is 0.002 N and the coefficient of viscosity 0.001 poise, distance between the plate is

A. 0.1 m

B. 0.05 m

C. 0.005 m

D. 0.0005 m

**Answer: D**



**Watch Video Solution**

7. A gas bubble of 2 cm diameter rises through a liquid  $1.75 \text{ gm cm}^{-3}$  with a fixed speed of  $0.35 \text{ cm s}^{-1}$ . Neglect the density of the gas. The coefficient of viscosity of the liquid is

A. 870 poise

B. 1120 poise

C. 982 poise

D. 1089 poise

**Answer: D**



**Watch Video Solution**

8. A rain drop of radius 0.3 mm falls through air with a terminal velocity of  $1\text{ms}^{-1}$ . The viscosity of air is  $18 \times 10^{-5}$  poise. The viscous force on the rain drop is

A.  $1.018 \times 10^{-2}$  dyne

B.  $2.018 \times 10^{-2}$  dyne

C.  $3.018 \times 10^{-2}$  dyne

D.  $4.018 \times 10^{-2}$  dyne

**Answer: A**



**Watch Video Solution**

**9.** A solid sphere falls with a terminal velocity  $v$  in air .If it is allowed to fall in vaccum,

A. terminal velocity of sphere =  $v$

B. terminal velocity of sphere  $< v$

C. terminal velocity of sphere  $> v$

D. sphere never attains terminal velocity

**Answer: D**



**Watch Video Solution**

**10.** After terminal velocity is reached the acceleration of a body falling through a viscous fluid is:

A. zero

B. equal to  $g$

C. less than  $g$

D. more than  $g$

**Answer: A**



**Watch Video Solution**

**11.** A metallic sphere of mass  $M$  falls through glycerine with a terminal velocity  $v$ . If we drop a ball of mass  $8M$  of same metal into a column

of glycerine, the terminal velocity of ball will be

A.  $2v$

B.  $4v$

C.  $8v$

D.  $16v$

**Answer: B**



**View Text Solution**

12. A metal ball  $B_1$  (density  $3.2g/cc$ ) is dropped in water, while another metal ball  $B_2$  (density  $6.0g/cc$ ) is dropped in a liquid of density  $1.6g/cc$ . If both the balls have the same diameter and attain the same terminal velocity, the ratio of viscosity of water to that of the liquid is

A. 2

B. 0.5

C. 4



D. indeterminate due to insufficient data

**Answer: B**



**Watch Video Solution**

**13.** Eight drops of water, each of radius  $2\text{mm}$  are falling through air at a terminal velocity of  $8\text{cm s}^{-1}$ . If they coalesce to form a single drop, then the terminal velocity of combined drop will be

A.  $1.32\text{cm s}^{-1}$

B. 2.  $30\text{cm s}^{-1}$

C. 3.  $28\text{cm s}^{-1}$

D. 4.  $24\text{cm s}^{-1}$

**Answer: A**



**Watch Video Solution**

**14.** A drop of water of radius 0.0015 mm is falling in air .If the coefficient of viscosity of air is  $2.0 \times 10^{-5} \text{kg m}^{-1} \text{s}^{-1}$  ,the terminal velocity of the drop will be

(The density of water =  $10^3 \text{kgm}^{-3}$  and  $g = 10 \text{ms}^{-2}$  )

A.  $1.0 \times 10^{-4} \text{ms}^{-1}$

B.  $2.0 \times 10^{-4} \text{ms}^{-1}$

C.  $2.5 \times 10^{-4} \text{ms}^{-1}$

D.  $5.0 \times 10^{-4} \text{ms}^{-1}$

**Answer: C**



**Watch Video Solution**

15. Water is conveyed through a uniform tube of 8 cm in diameter and 3140 m in length at the rate  $2 \times 10^{-3} m^3$  per second. The pressure required to maintain the flow is ( viscosity of water  $=10^{-3}$  )

A.  $1.625 \times 10^3 Nm^{-2}$

B.  $0.625 Nm^{-2}$

C.  $0.0625 Nm^{-2}$

D.  $0.00625 Nm^{-2}$

**Answer: A**



Watch Video Solution

## Reynolds Number

1. The onset of turbulence in a liquid is determined by

- A. 1. Pascal's law
- B. 2. Reynold's law
- C. 3. Torricell's law
- D. 4. Bernoulli's principle

**Answer: B**



**Watch Video Solution**

2. The ratio of inertial force to viscous force represents

- A. Magnus effect
- B. Reynolds number
- C. Torricell's law
- D. Relative density

**Answer: B**



**Watch Video Solution**

**3.** For turbulent flow, the value of Reynolds number is

A. 1.  $R_e > 2000$

B. 2.  $R_e < 2000$

C. 3.  $1000 < R_e < 2000$

D. 4.  $R_e = 1000$

**Answer: B**



**Watch Video Solution**

4. The flow rate from a tap of diameter  $1.25\text{cm}$  is  $3\text{ L//min}$ . The coefficient of viscosity of water is  $10^{-3}\text{ pa}\cdot\text{s}$ . Characterize the flow.

- A. 1. Unsteady
- B. 2. Turbulent
- C. 3. Laminar
- D. 4. None of above



**Answer: B**



**Watch Video Solution**

## Surface Tension

1. Which of the following is associated with liquid only and not for gas ?

A. 1. Pressure

B. 2. Volume

C. 3. Density

D. 4. Surface tension

**Answer: D**



**Watch Video Solution**

2. The rain are in spherical shape due to

A. 1. Viscosity

B. 2. surface tension

C. 3. Thrust on drop

D. 4. Both (a) and (b)

**Answer: B**



**Watch Video Solution**

**3. Which of the following statements is not true about surface tension ?**

A. A small liquid drop takes spherical shape

due to surface tension.

B. Surface tension is a vector quantity

C. Surface tension of liquid is a molecular phenomenon

D. Surface tension of liquid depends on length but not on the area

**Answer: B**



**Watch Video Solution**

**4. For a surface molecule,**

A. the net force on it is non zero

B. the net force on it zero

C. there is net downward force

D. there is net upward force

**Answer: C**



**Watch Video Solution**

5. Mercury does not wet glass. This is the property of liquid known as

A. Adhesion

B. Surface tension

C. Viscosity

D. Compressibility

**Answer: A**



**Watch Video Solution**

6. A thin liquid film formed between a  $U$  – shaped wire and a light slider supports a weight of  $1.5 \times 10^{-2} N$  (see figure). The length of the slider is  $30\text{cm}$  and its weight negligible.

The surfaces tension of the liquid film is :

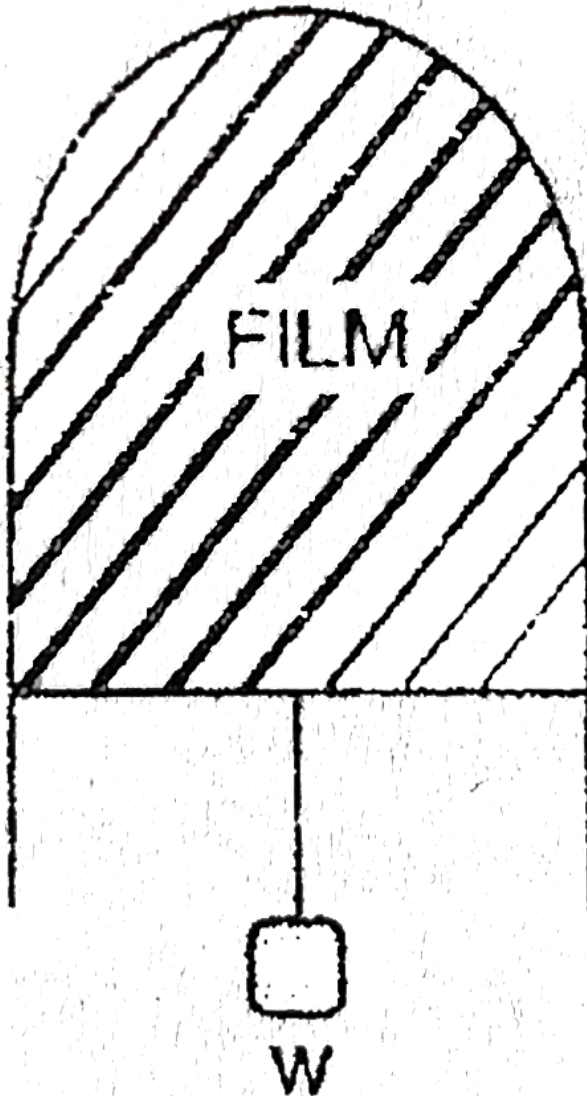

A.  $0.0125 \text{Nm}^{-1}$

B.  $0.1Nm^{-1}$

C.  $0.05Nm^{-1}$

D.  $0.025Nm^{-1}$

**Answer: D**



**Watch Video Solution**

7. Which graph represents the variation of surface tension with temperature over small temperature ranges for water?



A.

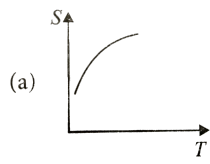

B.

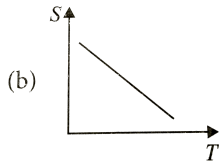

C.

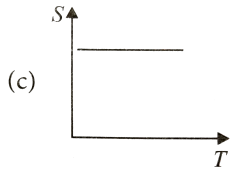

D.

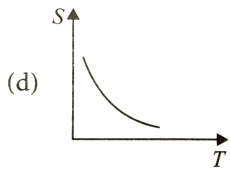

**Answer: B**



**Watch Video Solution**

8. Angle of contact of a liquid with a solid depends on

A. solid only

B. liquid only

C. both on solid and liquid

D. orientation of the solid surface in liquid

**Answer: C**



**Watch Video Solution**

9. Which of the following statements is not true about angle of contact ?

A. The value of contact for pure water and glass is zero

B. Angle of contact increases with increase in temperature of liquid

C. If the angle of contact of a liquid and a solid surface is less than  $90^0$  , then the liquid spreads on the surface of solid

D. Angle of contact doesnot depend upon the inclination of the solid surface to the liquid surface.

**Answer: D**



**Watch Video Solution**

**10.** Which of the following statements is correct ?

A. Viscosity is a vector quantity

B. Surface tension is a vector quantity

C. Reynolds number is a dimensionless quantity

D. Angle of contact is a vector quantity

**Answer: D**



**Watch Video Solution**

**11.** A liquid will not wet the surface of a solid if the angle of contact is

A. zero

B. equal to  $45^\circ$

C. equal to  $90^\circ$

D. greater than  $90^\circ$

**Answer: D**



**Watch Video Solution**

**12.** The soap bubble formed at the end of the tube is blown very slowly. Draw the graph

between excess of pressure inside the bubble  
with time.

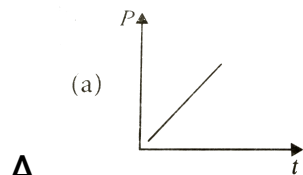

A.

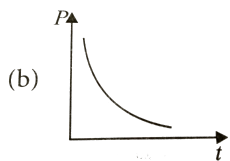

B.

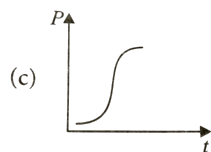

C.

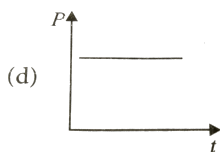

D.

**Answer: B**



**Watch Video Solution**

13. When a drop splits up into number of drops

- A. area increases
- B. volume increases
- C. energy is absorbed
- D. Both (a) and (b)

**Answer: D**



**Watch Video Solution**



14. The excess pressure inside a soap bubble is thrice the excess pressure inside a second soap bubble. What is the ratio between the volume of the first and the second bubble?

A. 9 : 1

B. 1 : 3

C. 1 : 9

D. 3 : 1

**Answer: C**



Watch Video Solution

15. Work  $W$  is required to form a bubble of volume  $V$  from a given solution. What amount of work is required to be done to form a bubble of volume  $2V$  ?

A.  $4^{2/3}W_1$

B.  $4^{1/3}W_1$

C.  $2^{1/2}W_1$

D.  $2^{3/2}W_1$

**Answer: B**



**Watch Video Solution**

**16.** Find the work done in blowing a soap bubble of surface tension  $0.06Nm^{-1}$  from 2 cm radius to 5 cm radius.

A. 3.1mj

B. 1.25 mj

C. 2.51 mj

D. 4.55 mj

**Answer: A**



**Watch Video Solution**

17. The surface tension of soap solution is  $0.03N/m$ . The work done in blowing to from a soap bubble of surface area  $40cm^2$ , (in J), is

A.  $2.4 \times 10^{-4} \text{ J}$

B.  $1.2 \times 10^{-2} \text{ J}$

C.  $3.6 \times 10^{-4} \text{ J}$

D.  $4.2 \times 10^{-2} \text{ J}$

**Answer: A**



**Watch Video Solution**

**18.** Surface tension of mercury is  $0.465Nm^{-1}$ .

The excess pressure inside a mercury drop of diameter 6mm is

A. 310 pa

B. 410 pa

C. 510 pa

D. 610 pa

**Answer: A**



**Watch Video Solution**

**19.** The surface tension of soap solution at a temperature  $20^{\circ}\text{C}$  is  $2.5 \times 10^{-2}\text{Nm}^{-1}$ . The excess pressure inside a bubble of soap solution of radius 6mm is

A. 12.5 pa

B. 14.2 pa

C. 15.5 pa

D. 16.7 pa

**Answer: D**



**Watch Video Solution**

**20.** In question number 88, if an air bubble of the same dimensions were formed at a depth of 30 cm inside a container containing the soap solution of relative density 1.20, then the pressure inside the bubble is ( Take 1 atm =  $1.01 \times 10^5$  Pa)

A.  $1.01 \times 10^4$  Pa

B.  $1.05 \times 10^5$  Pa

C.  $2.01 \times 10^4$  Pa

D.  $3.01 \times 10^4$  Pa

**Answer: B**



**Watch Video Solution**

**21.** The surface tension and vapour pressure of water at  $20^\circ\text{C}$  is  $7.28 \times 10^{-2} \text{Nm}^{-1}$  and  $2.33 \times 10^3$  Pa respectively. The radius of the



smallest spherical water droplet which can form without evaporating at  $25^{\circ}\text{C}$  is

A.  $1.25 \times 10^{-5} \text{ m}$

B.  $6.25 \times 10^{-5} \text{ m}$

C.  $4.3 \times 10^8 \text{ m}$

D.  $3.4 \times 10^3 \text{ m}$

**Answer: B**



**Watch Video Solution**

22. When a capillary tube is dipped in a liquid, the liquid rises to a height  $H$  in the tube. The free liquid surface inside the tube is hemispherical in shape. The tube is now pushed down so that the height of the tube outside the liquid is less than  $H$ . Then the

A. liquid will come out of the tube like in a small fountain

B. liquid will ooze out of the tube slowly

C. free liquid surface inside the tube is hemispherical

D. the liquid will fill the tube but not come out its upper end.

**Answer: D**



**Watch Video Solution**

**23.** A capillary tube is taken from the Earth to the surface of the moon. The rise of the liquid column on the Moon (acceleration due to

gravity on the Earth is 6 times that of the Moon) is

- A. six times that on the earth's surface
- B.  $\frac{1}{6}$  that on the earth surface
- C. equal on that of the earth surface
- D. zero

**Answer: A**



**Watch Video Solution**

24. A capillary tube (A) is dipped in water. Another identical tube (B) is dipped in a soap-water solution. Which of the following shows the relative nature of the liquid columns in the two tubes?

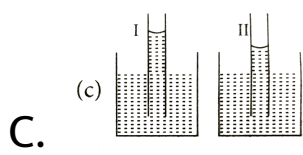
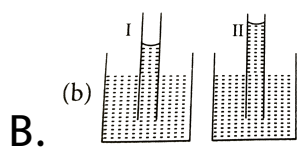
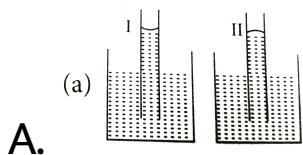

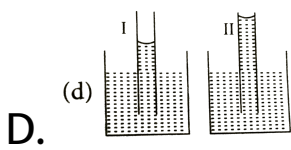

**Answer: C**



**Watch Video Solution**

**25.** The radii of the two columns in U-tube are  $r_1$  and  $r_2$  ( $r_2 > r_1$ ). When a liquid of density  $\rho$  (angle of contact is  $0^\circ$ ) is filled in it, the level difference of liquid in two arms is  $h$ . The surface tension of liquid is

( $g =$  acceleration due to gravity)

A.  $\frac{\rho g h r_1 r_2}{2(r_2 - r_1)}$

B.  $\frac{\rho g h (r_1 - r_2)}{2r_1 r_2}$

C.  $\frac{2(r_2 - r_1)}{\rho g h r_1 r_2}$

D.  $\frac{\rho g h}{2(r_2 - r_1)}$

**Answer: A**



**Watch Video Solution**

**26.** The sap in tree rises in a system of capillaries of radius  $2.5 \times 10^{-2} m$ . The surface tension of the sap is  $7.28 \times 10^{-2} N m^{-1}$  and

the angle of contact is  $0^\circ$ . The maximum height to which sap can rise in tree through capillarity action is ( $\rho_{\text{sap}} = 10^3 \text{kgm}^{-3}$ )

A. 0.21 m

B. 0.59 m

C. 0.87 m

D. 0.91 m

**Answer: B**



**Watch Video Solution**



27. Mercury has an angle of contact equal to  $140^\circ$  with soda lime glass. A narrow tube of radius  $1.00\text{mm}$  made of this glass is dipped in a trough containing mercury. By what amount does the mercury dip down in the tube relative to the mercury surface outside? Surface tension of mercury at the temperature of the experiment is  $0.465\text{Nm}^{-1}$ . Density of mercury =  $13.6 \times 10^3\text{kgm}^{-3}$ .

A. 5.34 mm

B. 2.35 mm

C. 6.25 mm

D. 1.44 mm

**Answer: A**



**Watch Video Solution**

**28.** Two capillaries of same length and radii in the ratio 1 : 2 are connected in series. A liquid flows through them in streamlined condition. If the pressure across the two extreme ends of

the combination is 1 m of water, the pressure difference across first capillary is

A. 9.4 m

B. 4.9 m

C. 0.49 m

D. 0.94 m

**Answer: D**



**Watch Video Solution**

29. If the surface tension of water is  $0.06 \text{ N/m}$ , then the capillary rise in a tube of diameter  $1 \text{ mm}$  is ( $\theta = 0^\circ$ )

A.  $1.22 \text{ cm}$

B.  $2.44 \text{ cm}$

C.  $3.12 \text{ cm}$

D.  $3.86 \text{ cm}$

**Answer: B**



**Watch Video Solution**

30. The rise in the water level in a capillary tube of radius 0.07 cm when dipped vertically in a beaker containing water of surface tension  $0.07 \text{ Nm}^{-1}$  is ( $g = 10 \text{ ms}^{-2}$ )

A. 2 cm

B. 4 cm

C. 1.5 cm

D. 3 cm

**Answer: A**



**Watch Video Solution**

31. A capillary tube of radius  $r$  is immersed in water and water rises in to a height  $h$ . The mass of water in the capillary tube is 5g. Another capillary tube of radius  $2r$  is immersed in water. The mass of water that will rise in this tube is

A. 2.5 g

B. 5.0 g

C. 10 g

D. 20 g

**Answer: C**



**Watch Video Solution**

## **Ncert Exemplar**

1. A tall cylinder is filled with viscous oil. A round pebble is dropped from the top with zero initial velocity. From the plot shown in figure, indicate the one that represents the

velocity ( $v$ ) of the pebble as a function of time ( $t$ )

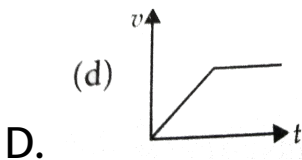
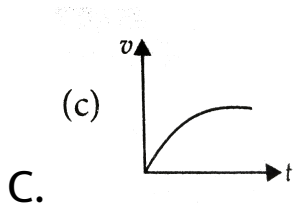
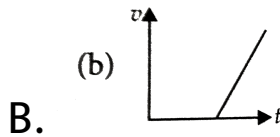
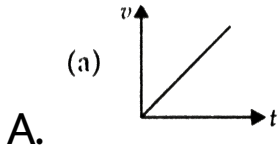

**Answer: C**



**Watch Video Solution**



2. Which of the following diagrams does not represent a streamline flow?

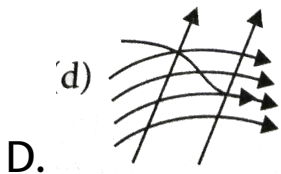
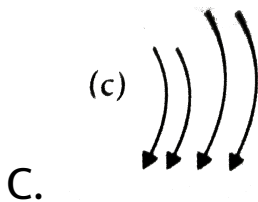
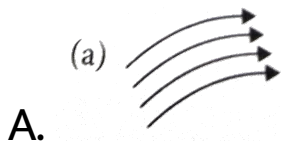

**Answer: D**



**View Text Solution**

**3. Along a streamline,**

A. the velocity of a fluid particle remains  
constant

B. the velocity of all fluid particles crossing  
a given position is constant

C. the velocity of all fluid particles at a given instant is constant

D. the speed of a fluid particle remains constant

**Answer: B**



**View Text Solution**

4. An ideal fluid flows through a pipe of circular cross-section made of two sections

with diameters  $2.5\text{cm}$  and  $3.75\text{cm}$ . The ratio of the velocities in the two pipes is

A.  $9:4$

B.  $3:2$

C.  $\sqrt{3}:\sqrt{2}$

D.  $\sqrt{2}:\sqrt{3}$

**Answer: A**



**Watch Video Solution**

5. The angle of contact at the interface of water glass is  $0^\circ$  ethylalcohol-glass is  $0^\circ$  mercury glass is  $140^\circ$  and methyl iodide-glass is  $30^\circ$  A glass capillary is put in a trough containing one of these four liquids. It is observed that the meniscus is convex. The liquid in the through is

A. water

B. ethylalcohol

C. mercury

D. methyl iodide

**Answer: C**



**Watch Video Solution**

**Others**

1. Bernoulli's equation for steady, non-viscous, incompressible flow expresses the

A. 1. conservation of linear momentum

B. 2. conservation of angular momentum

C. 3. conservation of energy

D. 4. conservation of mass

**Answer: C**



**Watch Video Solution**

2. In old age arteries carrying blood in the human body become narrow resulting in an increase in the blood pressure, this follows from

A. 1. Pascal's law

B. 2. Stokes' law

C. 3. Bernoulli's principle

D. 4. Archimede's principle

**Answer: C**



**Watch Video Solution**

**3. Applications of Bernoulli's theorem can be seen in**



A. 1. dynamic lift of aeroplane

B. 2. hydraulic press

C. 3. helicopter

D. 4. none of these

**Answer: A**



**Watch Video Solution**

4. A liquid flows through a horizontal tube as shown in figure. The velocities of the liquid in the two sections, which have areas of cross-

section  $A_1$  and  $A_2$  and  $v_1$  and  $v_2$  respectively.

The difference in the levels of the liquid in the two vertical tubes is  $h$ . then

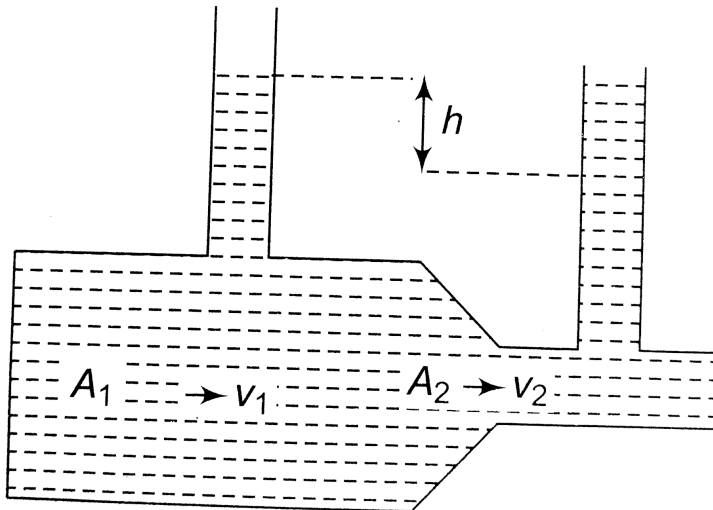

A.  $v_2^2 - v_1^2 = 2gh$

B.  $v_2^2 + v_1^2 = 2gh$

C.  $v_2^2 - v_1^2 = gh$

$$D. v_2^2 + v_1^2 = gh$$

**Answer: A**



**Watch Video Solution**

5. Which of the following figures shown below is correct regarding the steady flow of a non viscous liquid ?

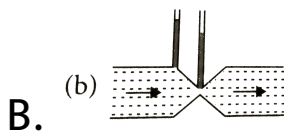
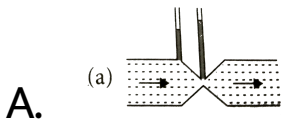

C.

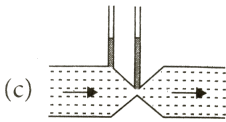

D.

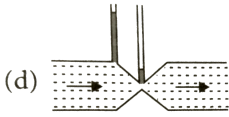

**Answer: A**



**Watch Video Solution**

6. An aircraft of mass  $4 \times 10^5 \text{ kg}$  with total wing area  $500 \text{ m}^2$  in level flight at a speed of  $720 \text{ kmh}^{-1}$ . The density of air at its height is  $1.2 \text{ kgm}^{-3}$ . The fractional increase in the

speed of the air on the upper surface of its wings relative to the lower surface is (take  $g = 10ms^{-2}$ )

A. 0.04

B. 0.08

C. 0.17

D. 0.34

**Answer: C**



**Watch Video Solution**

7. A plane is in level flight at constant speed and each of its two wings has an area of  $25m^2$ . If the speed of the air on the upper and lower surfaces of the wing are  $270kmh^{-1}$  and ' $234 km h^{(-1)}$ ' respectively, then the mass of the plane is (Take the density of the air  $= 1kgm^{-3}$ )

A. 1550 kg

B. 1750 kg

C. 3500 kg

D. 3200 kg

**Answer: C**



**Watch Video Solution**

**8.** A tank filled with fresh water has a hole in its bottom and water is flowing out of it. If the size of the hole is increased, then

A. the volume of water flowing out per second will decrease

B. the velocity of outflow of water remains unchanged

C. the volume of water volume out per second remains zero

D. Both (b) and (c)

**Answer: B**



**Watch Video Solution**

9. A water barrel stands on a table of height  $h$ . If a small hole is punched in the side of the barrel at its base, it is found that the resultant stream of water strikes the ground at a



horizontal distance  $R$  from the table. What is the depth of water in the barrel?

A.  $\frac{R^2}{h}$

B.  $\frac{R^2}{2h}$

C.  $\frac{R^2}{4h}$

D.  $\frac{4R^2}{h}$

**Answer: C**



**Watch Video Solution**

10. Torricelli's barometer used mercury but pascal duplicated it using French wine of density  $984\text{kgm}^{-3}$ . In that case, the height of the wine column for normal atmospheric pressure is

(Take the density of mercury =  $1.36 \times 10^3\text{kgm}^{-3}$ )

A. 5.5 m

B. 10.5 m

C. 9.8 m

D. 15 m

**Answer: B**



**Watch Video Solution**

**11.** A cylinder of height 20 m is completely filled with water. The velocity of efflux of water through a hole on the side wall of the cylinder near its bottom is (Take  $g = 10ms^{-2}$ )

A.  $10ms^{-1}$

B.  $20ms^{-1}$

C.  $25.5\text{ m s}^{-1}$

D.  $5ms^{-1}$

**Answer: B**



**Watch Video Solution**

**12.** At What velocity does water emerge from an orifice in a tank in which gauge pressure is  $3 \times 10^5 Nm^{-2}$  before the flow starts ? (Take the density of water =  $1000kgm^{-3}$ .)

A.  $24.5ms^{-1}$

B.  $14.5ms^{-1}$

C.  $34.5ms^{-1}$

D.  $44.5ms^{-1}$

**Answer: A**



**Watch Video Solution**

**13.** Which of the following device is used to measure the rate of liquid through a pipe ?

A. Thermometer

B. Barometer

C. Manometer

D. Venturimeter

**Answer: D**



**Watch Video Solution**

**14.** The flow of blood in a large artery of a anesthetized dog is diverted through a venturimeter. The wider part of the meter has

a cross-sectional area equal to that of the artery. i.e.,  $10\text{mm}^2$ . The narrower part has an area  $5\text{mm}^2$ . The pressure drop in the artery is  $22\text{Pa}$ . Density of the blood is  $1.06 \times 10^3 \text{kg m}^{-3}$ . The speed of the blood in the artery is

A.  $0.12\text{ms}^{-1}$

B.  $0.62\text{ms}^{-1}$

C.  $0.24\text{ms}^{-1}$

D.  $0.42\text{ms}^{-1}$

**Answer: A**



15. Dynamic lift due to spinning is a) Magnus effect b) Doppler effect c) Pascal effect d) Torricelli's effect

A. Magnus effect

B. Doppler effect

C. Pascal effect

D. Torricelli's effect

**Answer: A**





**Watch Video Solution**