



MATHS

BOOKS - MHTCET PREVIOUS YEAR PAPERS AND PRACTICE PAPERS

Linear Programming

Exercise 1 Topical Problems Linear Programming Problem And Its General Form

1. In case of a linear programming problem, feasible region is always

A. a convex set

B. a concave set

C. a bounded convex set

D. a bounded concave set

Answer: A



Watch Video Solution

2. In linear programming problem, the linear function Z subject to certain conditions determined by a set of linear inequalities with variables as non-negative, is

A. maximised only

B. minimised only

C. Both (a) and (b)

D. None of these

Answer: C



[Watch Video Solution](#)

3. A problem which seeks to maximise or minimise a linear function (say, of two variables x and y) subject to certain constraints as determined by a set of linear inequalities is called a/an

- A. optimisation problem
- B. functional problem
- C. numerical problem
- D. computer problem

Answer: A



[Watch Video Solution](#)

4. The linear inequalities or equations or restrictions on the variables of a linear programming problem are called A) linear relations B) constraints C) functions D) objective functions

A. linear relations

B. constraints

C. functions

D. objective functions

Answer: B



Watch Video Solution

5. Consider the following statements

The term linear implies that all mathematical relations used in the problem are linear relations. II. The term programming refers to the method of determining a particular programme.

Choose the correct option.

- A. Only I is true
- B. Only II is true-
- C. Both I and II are true
- D. Neither I nor II is true

Answer: C



Watch Video Solution

6. A furniture dealer deals in only two items - tables and chairs, He has 50000 to invest and has storage space of at most 60 pieces. A table costs ₹ 2500 and a chair ₹ 500. Then, the constraints of the above problem are (where, x is number of tables and y is number of chairs)

A. $x \geq 0, y \geq 0$

B. $5x + y \leq 100$

C. $x + y \leq 60$

D. All of these

Answer: D



Watch Video Solution

7. If a furniture dealer estimate that from the sale of one table he can make a profit of ₹ 250 and from the sale of one chair of a profit of ₹ 75 and if x is the sale of chairs and y us the number of tables , then its linear objectives function is

A. $Z = 75x + 250y$

B. $Z = 75x + 25Y$

C. $Z = 250 + 75y$

D. $Z = 25x + 75y$

Answer: A



Watch Video Solution

8. A linear programming problem is one that is concerned with finding theA.... Of a linear function calledB... function of several variables (say x and Y), subject to the conditions that the variables areC.... And satisfy set of linear inequalities called linear constraints .

Here, A,B C are respectively

- A. objective ,optimal value, negative
- B. optimal value, objective ,negative
- C. optimal value , objective ,non- negative
- D. objective ,optimal value, non- negative

Answer: C



Watch Video Solution

9. The conditions $x \geq 0, y \geq 0$ are called

- A. restrictions only
- B. negative restrictions
- C. non-negative restrictions
- D. None of these

Answer: C



Watch Video Solution

10. Which of the following is a linear objective ? A)

$z = ax + by$ B) $z \leq ax + by$ C) $z > ax + by$ D) $z \neq ax + by$

A. $Z = ax + by$

B. $Z \leq ax + by$

C. $Z > ax + by$

D. $Z \neq ax + by$

Answer: A



Watch Video Solution

11. The variables x and y in a linear programming problem are called A) decision variables B) linear variables C) optimal variables D) None of these

A. decision variables

B. linear variables

C. optimal variables

D. None of these

Answer: A



Watch Video Solution

12. Which of the following statements is false? A) The feasible region is always a concave region B) The maximum (or minimum) solution of the objective function occurs at the vertex of the feasible region C) If two corner points produce the same maximum (or minimum) value of the objective function, then every point on the line segment joining these points will also give the same maximum (or minimum) two. values D) All of the above

A. The feasible region is always a concave region

B. The maximum (or minimum) solution of the objective function occurs at the vertex of the feasible region

- C. If two corner points produce the same maximum (or minimum) value of the objective function, then every point on the line segment joining these points will also give the same maximum (or minimum) two. values
- D. All of the above

Answer: A

 [Watch Video Solution](#)

13. The optimal value of the objective function is attained at the points A) given by intersection of inequations with axes only B) given by intersection of inequations with X-axis only C) given by corner points of the feasible region D) none of teh above

- A. given by intersection of inequations with axes only
- B. given by intersection of inequations with X-axis only
- C. given by corner points of the feasible region
- D. None of the above

Answer: C



Watch Video Solution

14. Variables of the objective function of the linear programming problem are A) zero B) zero or positive C) negative D) zero or negative

A. zero

B. zero or positive

C. negative

D. zero or negative

Answer: B



Watch Video Solution

15. A furniture dealer deals in only two items - tables and chairs, He has 50000 to invest and has storage space of at most 60 pieces. A table costs ₹ 2500 and a chair ₹ 500. Then, the constraints of the above problem are (where, x is number of tables and y is number of chairs)

A. 2

B. 3

C. 4

D.1

Answer: C



Watch Video Solution

16. A furniture dealer deals in only two items - tables and chairs. He has 'Rs. 50000 invest and has storage place of at most 60 pieces. A table costs Rs. 2500 and chair Rs. 500. He estimates that from the sale of one table, he can make a profit of Rs. 250 and that from the sale of one chair a profit of Rs. 75. How many table and chair he should buy from the available money so as to maximise his total profit assuming that he can sell all the items which he buys.

A. maximise $Z=250x + 75Y$

Subject to the constraints

$$5x + y \leq 100$$

$$x + Y \leq 60$$

$$x, y \geq 0$$

B. minimise $Z= 250x + 75y$

Subject to the constraints

$$5xY \leq 100$$

$$x + y \leq 100$$

$$x, y \geq 0$$

C. minimise $Z = 250x + 75y$

Subject to the constraints

$$5x + y \geq 100$$

$$x + y \geq 60$$

$$x, y \geq 60$$

$$x, y \geq 0$$

D. maximise $Z = 250x + 75y$

Subject to the constraints

$$5x + y \leq 100$$

$$x + y \geq 60$$

$$x, y \geq 0$$

Answer: A



Watch Video Solution

17. The objective function of an LPP is A) a constraint B) a function to be optimised C) a relation between the variables D) none of these

A. a constraint

B. a function to be optimised

C. a relation between the variables

D. None of the above

Answer: B



[Watch Video Solution](#)

18. Which of the following sets are not convex? A)

$\{(x, y) : 8x^2 + 6y^2 \leq 24\}$ B) $\{(x, y) : 6 \leq x^2 + y^2 \leq 36\}$ C)

$$\{(x, y) : y \geq 3, y \geq 30\} \text{ D) } \{(x, y) : x^2 \leq y\}$$

A. $\{(x, y) : 8x^2 + 6y^2 \leq 24\}$

B. $\{(x, y) : 6 \leq x^2 + y^2 \leq 36\}$

C. $\{(x, y) : y \geq 3, y \geq 30\}$

D. $\{(x, y) : x^2 \leq y\}$

Answer: B



Watch Video Solution

19. One of the important class of optimisation problem is A) functional programming problem B) linear programming problem C) numerical programming problem D) none of these

A. functional programming problem

B. linear programming problem

C. numerical programming problem

D. None of the above

Answer: B



Watch Video Solution

20. The problems which seek to maximise (or minimise) profit (or cost) from a general class of problems called A) optimization problems B) customization problems C) Both A and B D) none of these

A. optimisation problems

B. customisation problems

C. Both (a) and (b)

D. None of these

Answer: A



Watch Video Solution

21. The wide applicability of linear programming problem is in
a A) industry B) commerce C) management science D) all of
these

A. industry

B. commerce

C. management science

D. All of these

Answer: A



[Watch Video Solution](#)

22. An optimisation problem may involve finding A) maximizing profit B) minimum cost C) minimum use of resources D) All of the above

- A. maximum profit
- B. minimum cost
- C. minimum use of resources
- D. All of the above

Answer: A



[Watch Video Solution](#)

23. If a young man rides his motorcycle at 25 km/hr, he has to spend 2 per kilometer on petrol if per he rides it at a faster speed of 40 km/hr the petrol cost increases to 5 per kilometer. He has 100 to spend on petrol and wishes to find the maximum distance he can travel within one hours. Express this as a linear programming problem and then solve it.

A. $2x + 5y \leq 100, \frac{x}{25} + \frac{y}{40} \geq 1, x \geq 0, y \geq 0$

B. $2x + 5y \geq 100, \frac{x}{25} + \frac{y}{40} \geq 1, x \geq 0, y \geq 0$

C. $2x + 5y \leq 100, \frac{x}{25} + \frac{y}{40} \leq 1, x \geq 0, y \leq 0$

D. $2x + 5y \leq 100, 25x + 40y \leq 1, x \geq 0, y \geq 0$

Answer: C



Watch Video Solution

24. Priya has to stitch table clothes and curtains for a living. She has to put in 1 hour of work for a table cloth and 3 hours for a curtain. She gets ₹ 50 for every table cloths and ₹ 250 for every curtain. She has to earn a least ₹ 500 per day. Minimize the no of hours of work she has to put in every day.

A. Miniimize $z = x + 3y$ subject to

$$250x + 50y \leq 500, x \geq 0, y \geq 0$$

B. Minimize $z = x + 3y$ subject to

$$50x + 250y \geq 500, x \geq 0, y \geq 0$$

C. Minimize $z = x + 3y$ subject to

$$250x + 250 \leq 500, x \geq , 0y \geq 0$$

D. Minimize $z = x + 3y$ subject to $250x + 250 \leq 500x \geq 0$

Answer: B



25. A factory owner purchases two types of machines, A and B for his factory. The requirements and the limitations for the machines are as follows:

Machine	Area occupied	Labour force
A	1000 m^2	12 men
B	1200 m^2	8 men

He has maximum area of 9000 m^2 available, and 72 skilled labourers who can operate both the machines. How many machines of each type should he buy to maximise the daily output?

A. Maximize $z = 50x + 40y$ subject to constraints:

$$x \geq 0, y \geq 0, 1000x + 1200y \leq 9000, 12x + 8y \leq 72$$

B. Maximize $z = 50x + 40y$ subject to constraints:

$$x \geq 0, y \geq 0, 1000x + 1200y \leq 7600, 12x + 8y \leq 72$$

C. Maximize $z = 50x + 40y$ subject to constraints

$$x \geq 0, y \geq 0, 1000x + 1200y \leq 7600, 12x + 8y \geq 72$$

D. Maximize $z = 50x + 40y$ subject to constraints:

$$x^2 \geq 0, y^2 \geq 0, 1000x + 1200y^2 \geq 7600, 12x + 8y^2 \geq 72.$$

Answer: A



Watch Video Solution

26. Let p and q be the statements

$$p: 4x + 5y \geq 20, q: 3x^2 + 2y^2 \leq 6$$

Can p and q both be constraints for an LPP?

A. both p and q can be constraints of LPP

B. p but not q is a constraint of LPP

C. q but not p is a constraint of LPP

D. neither p nor q is a constraint of LPP

Answer: B



Watch Video Solution

27. Which of the following cannot be considered as the objective function of a linear programming problem?

A) Maximize $z = 3x + 2y$ B) Minimize $z = 6x + 7y + 92$ C)

Maximize $z = 2x$ D) Minimize $z = x^2xy + y^2$

A. Maximize $z = 3x + 2y$

B. Minimize $z = 6x + 7y + 92$

C. Maximize $z = 2x$

D. Minimize $z = x^2 + 2xy + y^2$

Answer: D

 Watch Video Solution

28. The solution set of the linear inequalities $2x + y \geq 8$ and $x + 2y \geq 10$ is

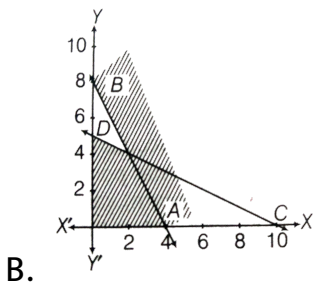
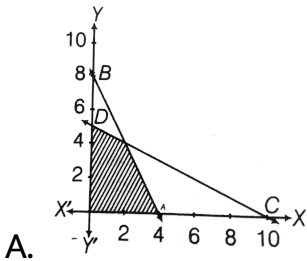

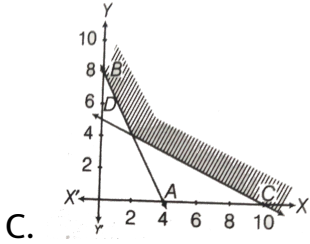

D. None of these

Answer: C

 [Watch Video Solution](#)

29. A printing company prints two types of magazines A and B . The company earns '10 and '15 on each magazine A and B respectively. These are processed on three machines I, II and III and total time in hours available per week on each machine is as follows.

Magazine →	$A (x)$	$B (y)$	Time available
↓ Machine			
I	2	3	36
II	5	2	50
III	2	6	60

The number of constraints is

A. 3

B. 4

C. 5

D. 6

Answer: C



[Watch Video Solution](#)

30. The region shaded horizontally is represented by the inequations

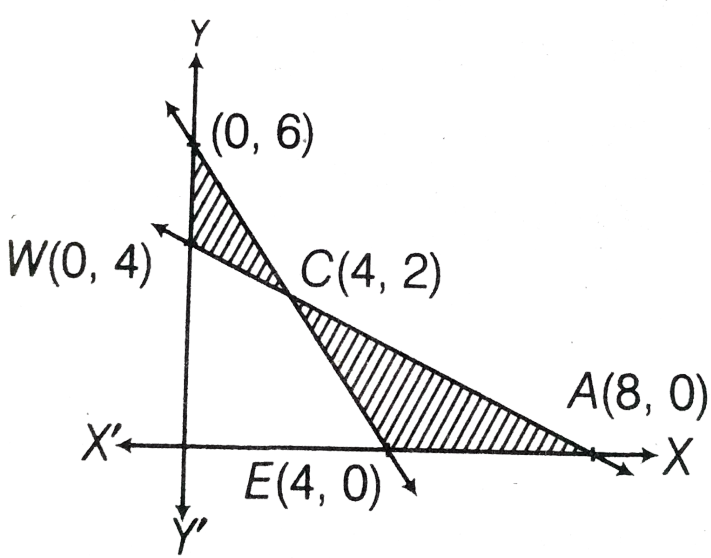

A. $y \geq 0, 3x + 2y \geq 12, x + 2y \leq 8$

B. $y \leq 0, 3x + 2y \leq 12, x + 2y \leq 8$

C. $y \geq 0, 3x + 2y \geq 12, x + 2y \geq 8$

D. $y \geq 0, 3x + 2y \leq 12, x + 2y \geq 8$

Answer: A



Watch Video Solution

31. Find the linear inequations for which the shaded area in following figure is the solution set:

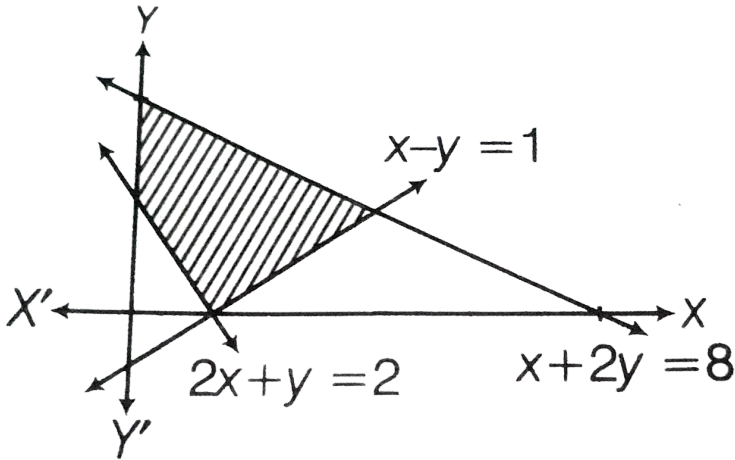

- A. $x + y \leq 1, 2x + y \geq 2, x - 2 \geq 8, x \leq 0, y \geq 0$
- B. $x - y \geq 1, 2x + y \geq 2, x \geq 0, y \geq 0$
- C. $x - y \geq 1, 2x + y \leq 2, x + 2y \geq 8, x \geq 0, y \geq 0$
- D. $x + y \geq 1, 2x + y \leq 2, x + 2y \geq 8, x \geq 0, y \geq 0$

Answer: C

 [Watch Video Solution](#)

32. The minimum value of $Z = 4x + 5y$ subject to the constraints $x \leq 30$, $y \leq 40$ and $x \geq 0$, $y \geq 0$ is

A. 320

B. 200

C. 120

D. 0

Answer: D



[Watch Video Solution](#)

33. Shaded region is represented by

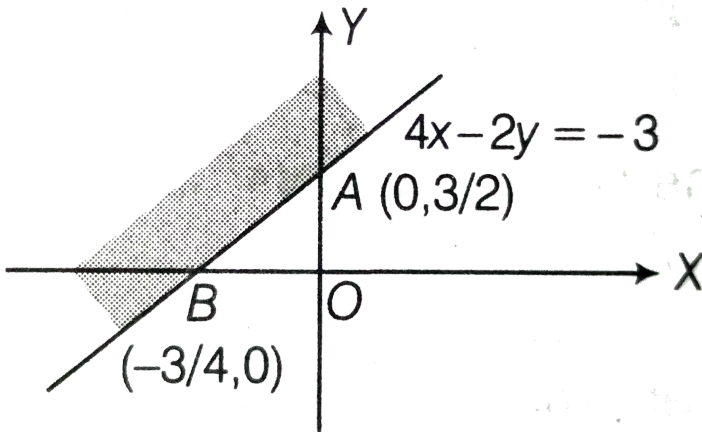

- A. $4x - 2y \leq 3$
- B. $4x - 2y \leq -3$
- C. $4x - 2y \geq 3$
- D. $4x - 2y \geq -3$

Answer: B

 [Watch Video Solution](#)

34. The shaded region for the inequality $x + 5y \leq 6$ is

A. to the non-origin side of $x + 5y = 6$

B. to the either side of $x + 5y = 6$

C. to the origin side of $x + 5y = 6$

D. to the neither side of $x + 5y = 6$

Answer: C



Watch Video Solution

35. The feasible region for the following constraints

$L_1 \leq 0, L_2 \geq 0, L_3 = 0, x \geq 0, y \geq 0$ in the diagram shown

is



A. area DHF

B. area AHC

C. line segment EG

D. line segment GI

Answer: C



[View Text Solution](#)

36. $3x + 4y \leq 18$, $2x + 3y \geq 3$ and $x, y \geq 0$ is

A. (0,2)

B. (4,8,0)

C. (0,3)

D. None of these

Answer: D



Watch Video Solution

37. The corner point method for bounded feasible region comprises of the following steps I.

When the feasible region is bounded, M and m are the maximum and minimum values of Z .

II. Find the feasible region of the linear programming problem and determine its corner points.

III. Evaluate the objective function $Z = ax + by$ at each corner point. Let M and m respectively be the largest and smallest values of these points. The correct order of these above steps is

A. III,I,II

B. II,III,I

C. II,I,III

D. I,III,II

Answer: B



[Watch Video Solution](#)

Exercise 1 Topical Problems Solution Of Lpp Graphical Method

1. Maximum value of $Z = 12x + 3y$ subject to constraints

$x \geq 0, y \geq 0, x + y \leq 5$ and $3x + y \leq 9$ is

A. 15

B. 36

C. 60

D. 40

Answer: B



Watch Video Solution

2. The coordinate of the point at which minimum value of $Z = 7x - 8y$, subject to the conditions constraints $x + y - 20 \leq 0, y \geq 5, \leq -5$ is

A. (20,0)

B. (15,5)

C. (0,5)

D. (0,20)

Answer: D



Watch Video Solution

3. The minimum value of the objective function $Z=2x+10y$ for linear constraints $x \geq 0, y \geq 0, x - y \geq 0, x - 5y \leq -5$ is

A. 10

B. 15

C. 12

D. 8

Answer: B



Watch Video Solution

4. The minimum value of $Z = 5x - 4y$ subject to constraints

$x + y \leq 10, y \leq 4, x, y > 0$ will be at the point

A. (10,4)

B. (-10,4)

C. (6,4)

D. (0,4)

Answer: D



[Watch Video Solution](#)

5. The maximum value of $z = 10x + 6y$ subject to constraints

$x \geq 0, y \geq 0, x + y \leq 12, 2x + y \leq 20$ is

A. 72

B. 80

C. 104

D. 110

Answer: C



Watch Video Solution

6. The feasible solution for a LPP is shown as below,

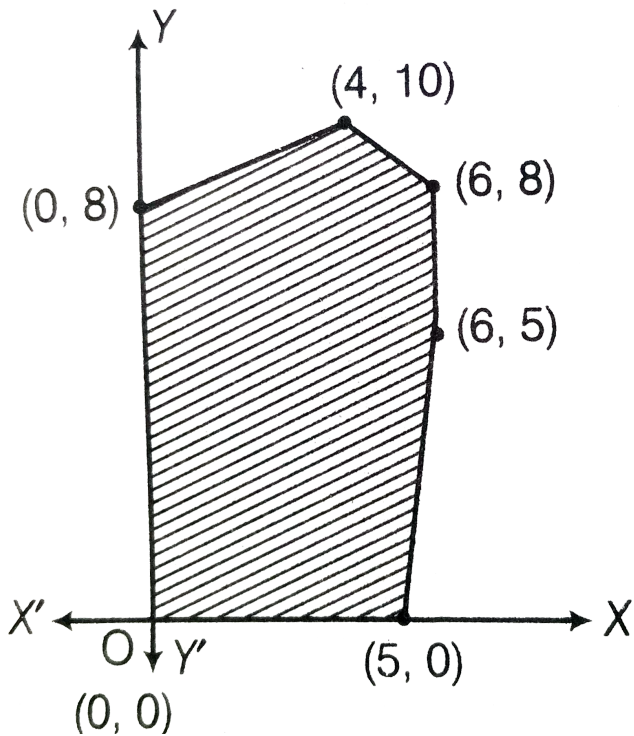

Let $Z = 3x - 4y$ be the objective function. Then,

Maximum of Z occurs at

A. (5,0)

B. (6,5)

C. (6,8)

D. (4,10)

Answer: A

 [Watch Video Solution](#)

7. The feasible solution for a LPP is shown as below,

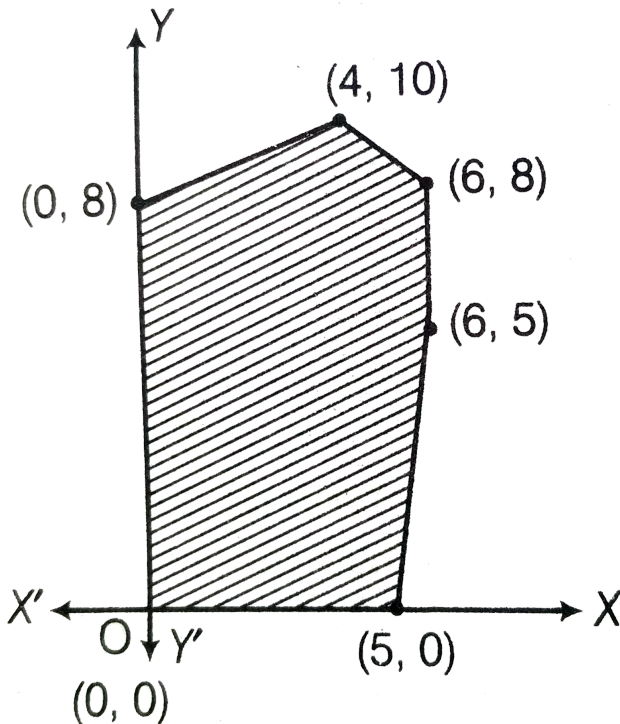

Let $Z = 3x - 4y$ be the objective function . Then, Minimum of Z

occurs at

A. (0,0)

B. (0,8)

C. (5,0)

D. (4,10)

Answer: B



[Watch Video Solution](#)

8. The feasible solution for a LPP is shown as below,



Let $Z = 3x - 4y$ be the objective function . Then, (Maximum value of Z + Minimum value of Z) is equal to

A. 13

B. 1

C. -13

D. -17

Answer: D



[View Text Solution](#)

9. The maximum value of $Z = 4x + 3y$, if the feasible region for an LPP is shown in following figure, is

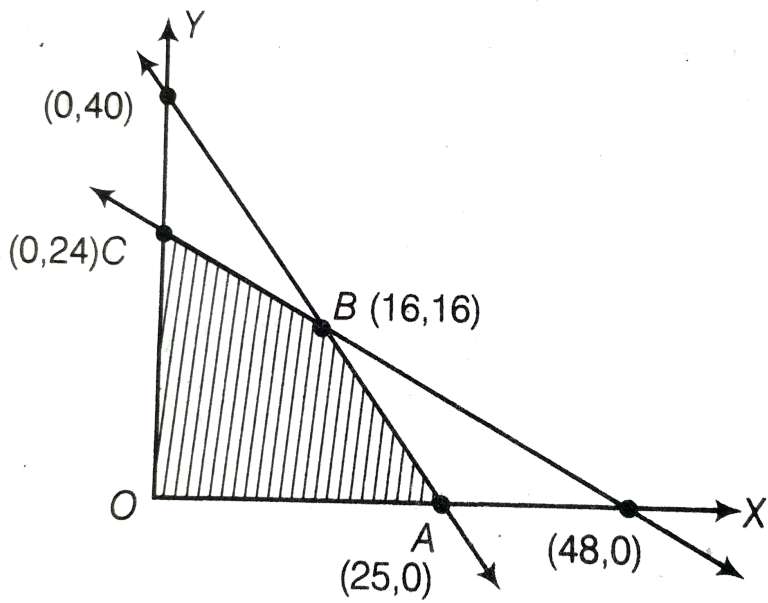

- A. 112
- B. 100
- C. 72
- D. 110

Answer: A



Watch Video Solution

10. The maximum value of $Z = x + 3y$ such that $2x + y \leq 20$, $x + 2y \leq 20$, $x \geq 0$, $y \geq 0$ is

A. 10

B. 60

C. 30

D. None of these

Answer: C



[Watch Video Solution](#)

11. The area of the feasible region for the following constraints

$3y + x \geq 3$, $x \geq 0$, $y \geq 0$ will be

A. bounded

B. unbounded

C. convex

D. concave

Answer: B



[Watch Video Solution](#)

12. The linear programming problem Maximise $Z = x_1 + x_2$

Subject to constraints

$$x_1 + 2x_2 \leq 2000$$

$$x_1 + x_2 \leq 15000$$

$$x_2 \leq 600$$

$$x_1 \geq \text{has}$$

A. no feasible solution

B. unique optimal solution

C. a finite number of optimal solutions

D. infinite number of optimal solutions

Answer: D



[Watch Video Solution](#)

13. Consider the linear programming problem Maximise $Z = 4x + y$.

Subject to constraints $x + y \leq 50$, $x + y \geq 100$ and $x, y \geq 0$

Then, maximum value of Z is

A. 0

B. 50

C. 100

D. does not exist

Answer: D



Watch Video Solution

14. The maximum and minimum values of the objective function $Z = 3x - 4y$ subject to the constraints

$$x - 2y \leq 0, \quad -3x + y \leq 4$$

$$x - y \leq 6, \quad x, y \geq 0$$

are respectively

A. 12,10

B. 10,12

C. 12,-16

D. 5,12

Answer: C



Watch Video Solution

15. The maximum value of $Z = 4x + 2y$ subject to the constraints

$$2x + 3y \leq 18, x + y \geq 10, x, y \geq 0 \text{ is}$$

A. 20

B. 36

C. 40

D. None of these

Answer: D



Watch Video Solution

Exercise 2 Miscellaneous Problems

1. The point which provides the solution of the linear programming problem, maximise $Z = 45x + 55y$. Subject to constraints Subject to constraints $x, y \geq 0, 6x + 4y \leq 120$ and $3x + 10y \leq 180$ is

A. (15, 10)

B. (10, 15)

C. (0,18)

D. (20,0)

Answer: B



[Watch Video Solution](#)

2. Determine the system of linear equation for which the solution set is the shaded region in the following figure

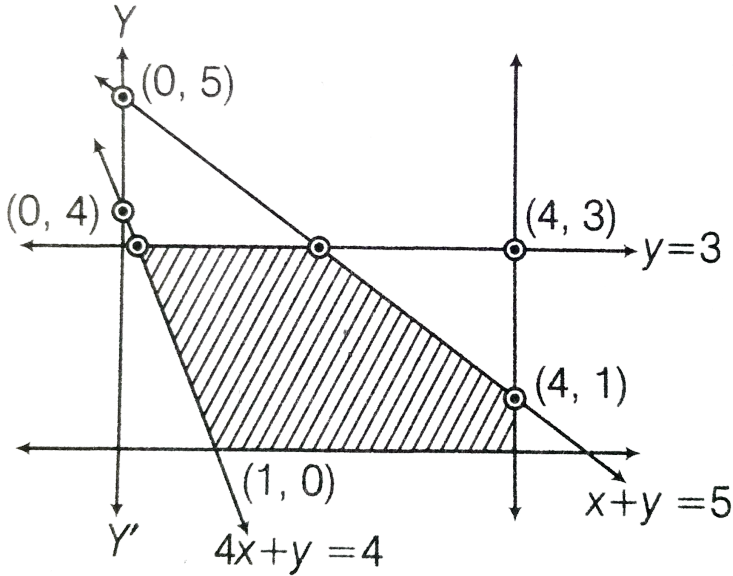

- A. If $x + y, 4 \leq 3, x + y \leq 5, 4x + y \geq 4, y \geq 0, x \geq 0$
- B. $x \leq 4, y \leq 3, x + y \geq 5, 4x + y \leq 4, y \geq 0, x \geq 0$
- C. $x \geq 4, y \geq 3, x + y \leq 5, 4x + y \geq 4, y \geq 0, x \geq 0$
- D. $x \geq 4, y \geq 3, x + y \geq 5, 4x + y \leq 4, y \geq 0,$

Answer: A



Watch Video Solution

3. if $x + y \leq 2$, $x \geq 0$ then point at which maximum value of $3x + 2y$ attained will be

A. (0,2)

B. (0,0)

C. (2,0)

D. $\left(\frac{1}{2}, \frac{1}{2}\right)$

Answer: C



Watch Video Solution

4. The solution set of the linear inequalities $2x + 2y \geq 10$ and $x + 2y \geq 10$

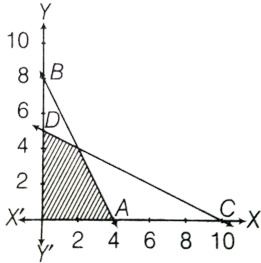

A.

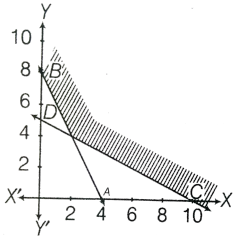

B.

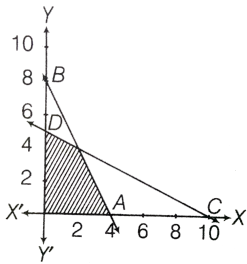

C.

D. None of these

Answer: B

 [Watch Video Solution](#)

5. Solve the linear programming problem. Maximise $Z = x + 2y$

Subject to constraints $x - y \leq 10$, $2x + 3y \leq 20$ and

$x \geq 0$, $y \geq 0$

A. $Z=10$

B. $Z=30$

C. $Z=40$

D. None of these

Answer: D

 [Watch Video Solution](#)

6. For an LPP, minimise $Z = 2x + y$ subject to constraint $5x + 10y \leq 50$, $x + y \geq 1$, $y \leq 4$ and $x, y \geq 0$ then Z is equal to

A. 0

B. 1

C. 2

D. 12

Answer: B



[Watch Video Solution](#)

7. Consider the inequalities

$x_1 + x_2 \leq 3$, $2x_1 + 5x_2 \geq 10$, $x_1, x_2 \geq 0$ then feasible region

is

A. (2,2)

B. (1,2)

C. (2,1)

D. (4,2)

Answer: B



Watch Video Solution

8. $Z = 4x + 2y$, $4x + 2y \geq 46$, $x + 3y \leq 24$ and x and y are greater than or equal to Zero, then the maximum value of Z is

A. 46

B. 96

C. 52

D. None of these

Answer: B



Watch Video Solution

9. The minimum value $Z = 2x_1 + 3x_2$ subject to the conditions $2x_1 + 7x_2 \geq 22$, $x_1 + x_2 \geq 6$, $5x_1 + x_2 \geq 10$ and $x_1, x_2 \geq 0$ is

A. 14

B. 20

C. 10

D. 16

Answer: A



[Watch Video Solution](#)

10. The maximum value $P = 3x + 4y$ subjected to the constraints $x + y \leq 40$, $x + 2y \leq 60$, $x \geq 0$ and $y \geq 0$ is

A. 130

B. 140

C. 40

D. 120

Answer: B



[Watch Video Solution](#)

11. Consider the inequalities

$$5x_1 + 4x_2 \geq 9, x_1 + x_2 \leq 3, x_1 \geq 0, x_2 \geq 0$$

Which of the following point lies inside the solution set ?

A. (1,3)

B. (1,2)

C. (1,4)

D. (2,2)

Answer: B



[Watch Video Solution](#)

12. The minimum and maximum values problem, of Z for the
minimise and maximise $Z = 3x + 9y$ subject to the constraints

$$x + 3y \leq 60, x + y \geq 10, x \leq y,$$

are respectively

A. 60 and 180

B. 180 and 60

C. 50 and 190

D. 190 and 50

Answer: A



[Watch Video Solution](#)

13. The linear programming problem minimise $Z=3x+2y$ subject to the constraints

$$x + y \geq 8$$

$$3x + 5y \leq 15$$

$x \geq 0, y \geq 0$ has

- A. one solution
- B. no feasible solution
- C. two solutions
- D. infinitely many solution

Answer: B



Watch Video Solution

14. The maximum and minimum values of the objective function $Z = x + 2y$ subject to the constraints

$x + 2y \geq 100, 2x - y \leq 0, 2x + y \leq 200$ occurs respectively

at

- A. one point and three points
- B. two points and one point
- C. one point and infinitely points
- D. one point and one point

Answer: C



Watch Video Solution

15. The maximum value of the objective function

$$Z=3x+4y$$

subject to the constraints $x + y \leq 4, x \geq 0, y \leq 0$ is

- A. 16
- B. 18

C. 20

D. 25

Answer: A



Watch Video Solution

16. Let x and y are the number of tables and chairs respectively, on which a furniture dealer wants to make profit for the constraints Maximise $Z = 250x + 75y$

$$5x + y \leq 100, x + y \leq 60, x \geq 0, y \geq 0$$

consider the following graph

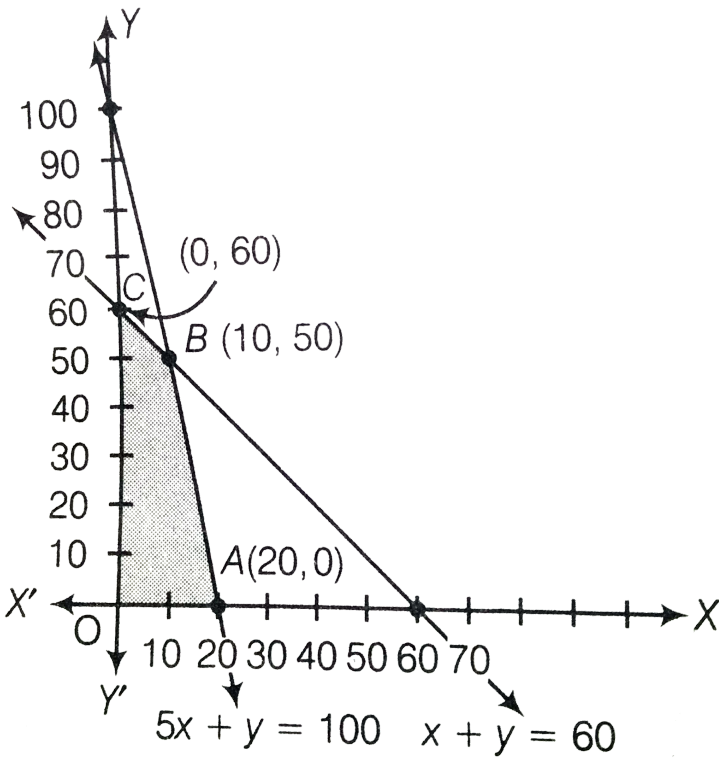

Then, the maximum profit to the dealer results from buying

- A. 10 tables and 50 chairs
- B. 50 tables and 10 chairs
- C. 0 table and 60 chairs
- D. 20 tables and 40 chairs

Answer: A



17. The graphical solution of linear inequalities

$$x + y \geq 5 \text{ and } x - y \leq 3,$$

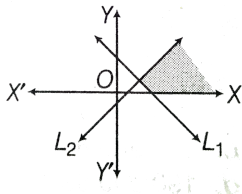

A.

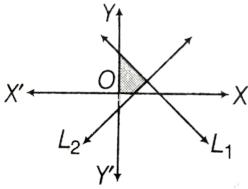

B.

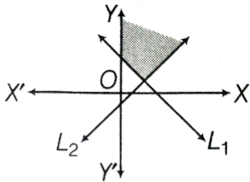

C.

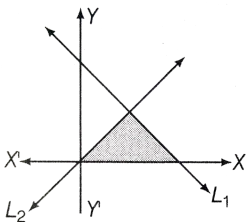

D.

Answer: C



Watch Video Solution

18. By graphical method, the solutions of linear programming problem maximum $Z = 3x_1 + 5x_2$ subject to constraints

$$3x_1 + 2x_2 \leq 18$$

$$x_1 \leq 4, x_2 \leq 6, x_1 \geq 0, x_2 \geq 0$$

A. $x_1 = 2, x_2 = 6, Z = 36$

B. $x_1 = 2, x_2 = 6, Z = 36$

C. $x_1 = 4, x_2 = 3, Z = 27$

D. $x_1 = 4, x_2 = 6, Z = 42$

Answer: B



Watch Video Solution

19. A toy company manufactures two types of doll; a basic version doll; a basic version doll A and a deluxe version doll B. Each doll of type B takes twice as long to produce as one of type A and the company would have time to ,make a maximum of 2, 000 per day if it produces only the basic version. The supply of plastic is sufficient to produce 1500 dolls per day (both A and B combined). The deluxe version requires a fancy dress of which there are only 600 per day available. If the company makes profit Rs. 3 and Rs. 5 per doll respectively o doll A and doll B; how many of each should be produced per day in order to maximize profit?

A. 800500

B. 500600

C. 450450

D. 1000, 500

Answer: D



Watch Video Solution

20. The minimum value of $Z = 10x + 4y$ subject to $4x + y \geq 4$, $x + 3y \geq 6$, $x + y \geq 3$, $x \geq 0$, $y \geq 0$ is

A. 60

B. 27

C. $\frac{74}{3}$

D. 32

Answer: C



Watch Video Solution

21. The point which provides the solution of the solution to the linear programming problem . Maximum $(2x+3y)$ subject to constraints .

$$4x + y \geq 4, x + 3y \geq 6, x + y \geq 3, x \geq 0, y \geq 0 \text{ is}$$

A. (3,2.5)

B. (2.3.5)

C. (2,3.5)

D. -1.35

Answer: D



Watch Video Solution

22. Shaded region is represented by , the constraints

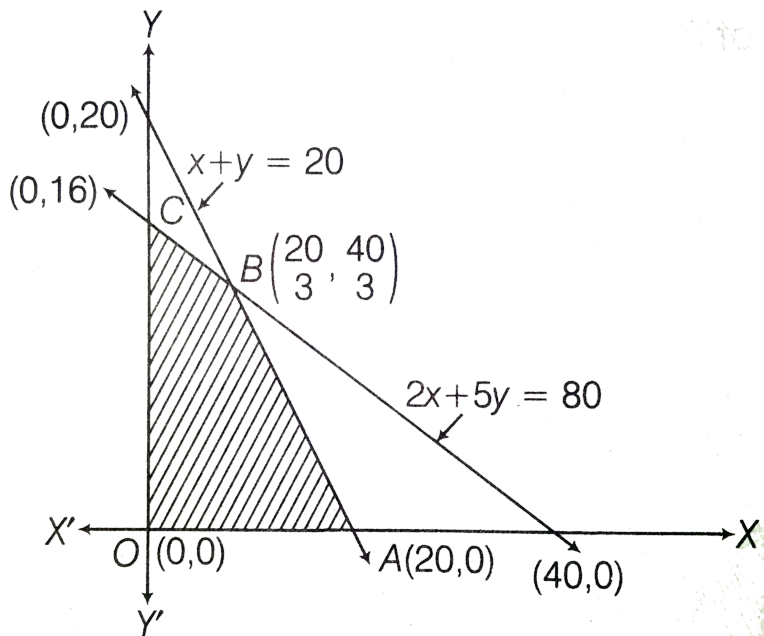

- A. $2x + 5y \geq 80, x + y \leq 20, x \geq 0, y \leq 0$
- B. $2x + 5y \geq 80, x + y \geq 20, x \geq 0, y \geq 0$
- C. $2x + 5y \geq 80, x + y \geq 20, x \geq 0, y \geq 0$
- D. $2x + 5y \leq 80, x + y \leq 20, x \leq 0$

Answer: C



23. Let R be the feasible region (convex polygon) for a linear programming problem and $Z = ax + by$ be the objective function. Then, which of the following statements is false? A) When Z has an optimal value, where the variables x and y are subject to constraints described by linear inequalities, this optimal value must occur at a corner point (vertex) of the feasible region. B) If R is bounded, then the objective function Z has both a maximum and a minimum value on R and each of these occurs at a corner point of R . C) If R is unbounded, then a maximum or a minimum value of the objective function may not exist. D) If R is unbounded and a maximum or a minimum value of the objective function z exists, it must occur at corner point of R .

- A. When Z has an optimal value, where the variables x and y are subject to constraints described by linear inequalities, this optimal value must occur at a corner point (vertex) of the feasible region .
- B. If R is bounded, then the objective function Z has both a maximum and a minimum value on R and each of these occurs at a corner point of R .
- C. If R is unbounded, then a maximum or a minimum value of the objective function may not exist
- D. If R is unbounded and a maximum or a minimum value of the objective function z exists, it must occur at corner point of R

Answer: D



Watch Video Solution

24. The minimum value of the objective function $Z=x+2y$

Subject to the constraints,

$$2x + y \geq 3, x + 2y \geq 6, x, y \geq 0 \text{ occurs}$$

- A. at every point on the line $x + 2y = 6$
- B. at every point on the line $2x + y = 3$
- C. at every point on the line $x + 2y = 3$ d
- D. at every point on the line $2x + y = 6$

Answer: A



Watch Video Solution

25. Let the feasible region of the linear programming problem with the objective function $Z = ax + by$ is unbounded and let M and m be the maximum and minimum value of Z , respectively.

Now, consider the following statements

I. M is the maximum value of Z , if the open half plane determined by $ax + by > M$ has no point in common with the feasible region. Otherwise, Z has no maximum value.

II. m is the minimum value of Z , if the open half plane determined by $ax + by < m$ has no point in common with the feasible region. Otherwise, Z has no minimum value. Choose the correct option.

A. Only I is true .

B. Only II is true

C. Both I and II are true

D. Neither I nor II is true

Answer: C

 [Watch Video Solution](#)

26. The minimum and maximum values of the objective function, $Z = 5x + 10y$ subject to the constraints $x + 2y \leq 120, x + y \geq 60, x - 2y \geq 0, x, y \leq 0$ are respectively

A. 300 and 500

B. 600 and 700

C. 600 and 700

D. 300 and 400

Answer: B



Watch Video Solution

27. Consider the following statements

I. If the feasible region of an LPP is unbounded then maximum or minimum value of the objective function $Z = ax + by$ may or may not exist .

II. Maximum value of the objective function $Z = ax + by$ in an LPP always occurs at only one corner point of the feasible region.

III. In an LPP, the minimum value of the objective function $Z = ax + by$ is always 0, if origin is one of the corner point of the feasible region.

IV. In an LPP, the maximum value of the objective function $Z =$

$ax + by$ is always finite.

Which of the following statements are true?

A. I and IV

B. II and III

C. I and III

D. II and IV

Answer: A



[Watch Video Solution](#)

28. The corner points of the feasible region determined by the system of linear constraints are $(0, 10)$, $(5, 5)$, $(15, 15)$, $(0, 20)$. Let $Z = px + qy$, where $p, q > 0$. Then, the condition on p and q so

that the maximum of Z occurs at both the points $(15, 15)$ and $(0, 20)$, is

- A. $p=q$
- B. $p=2q$
- C. $q=2p$
- D. $q=3p$

Answer: D



[Watch Video Solution](#)

29. (Allocation problem) A cooperative society of farmers has 50 hectare of land to grow two crops X and Y. The profit from crops X and Y per hectare are estimated as Rs 10,500 and Rs

9,000 respectively. To control weeds, a liquid herbicide has to be

- A. 20 hec for crop X and 30 hec for crop Y
- B. 20 hec each for both crop X and crop Y
- C. 30 hec for crop X and 20 hec for crop Y
- D. 30 hec each for both crop X and crop Y 30

Answer: C



Watch Video Solution

30. Anil wants to invest at the most Rs.12000 in bonds. A and B. According to rules, he has to invest at least Rs.2000 in Bond A is 8 % per annum and on Bond B, it is 10 % per annum, how

should he invest his money for maximum interest ? Solve the problem graphically.

A. ₹ 10000 and ₹ 2000

B. ₹ 2000 and ₹ 10000

C. ₹ 6000 and ₹ 6000

D. None of these

Answer: B



Watch Video Solution

Mht Cet Corner

1. The shaded part of given figure indicates infeasible region

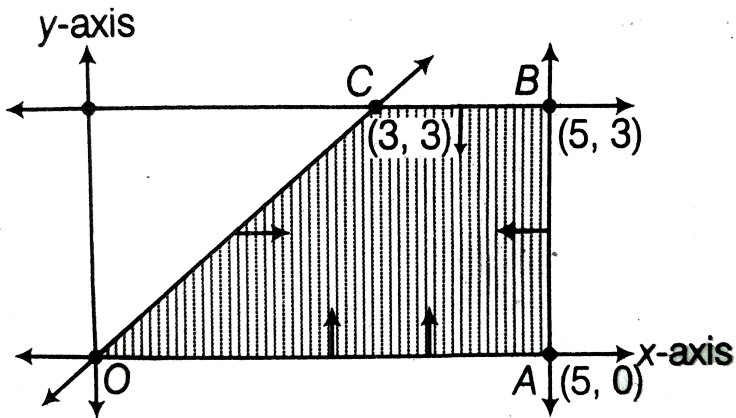

then the constraints are

A. $x, y \geq 0, x + y \geq 0, x \geq 5, y \leq 3$

B. $x, y \geq 0, x - y \geq 0, x \leq 5, y \leq 3$

C. $x, y \geq 0, x - y \geq 0, x \leq 5, y \geq 3$

D. $x, y \geq 0, x - y \leq 0, x \leq 5, y \leq 3$

Answer: B



Watch Video Solution

2. The objective function $Z = x_1 + x_2$ subject to the constraints:

$x_1 + x_2 \leq 10$, $-2x_1 + 3x_2 \leq 15$, $x_1 \leq 6$, $x_1, x_2 \geq 0$ has maximum value _____ of the feasible region .

- A. at only two points
- B. at only two points
- C. at every point of the segment joining two points
- D. at every point of the line joining two points

Answer: C



Watch Video Solution

3. The constraints

$-x_1 + x_2 \leq 1$, $-x_1 + 3x_2 \leq 9$, $x_1, x_2 > 0$ defines

- A. bounded feasible space
- B. unbounded feasible space
- C. both bounded and unbounded feasible space
- D. None of the above

Answer: B



[Watch Video Solution](#)

4. The maximum value of $Z = 3x + 2y$ for linear
 $x + y \leq 7$, $2x + 3y \leq 16$, $x \geq 0$, $y \geq 0$ is the objective
function constraints

A. 16

B. 21

C. 25

D. 28

Answer: B



Watch Video Solution

5. The maximum value of $Z = 9x + 13y$ subject to constraints

$$2x + 3y \leq 18, 2x + y \leq 10, x \geq 0, y \geq 0$$

A. 130

B. 81

C. 79

D. 28

Answer: C

 [Watch Video Solution](#)

6. For the LPP, Min $Z = x_1 + x_2$ such that inequalities $5x_1 + 10x_2 \geq 0$, $x_1 + x_2 \leq 1$, $x_2 \leq 4$ and $x_1, x_2 \geq 0$

- A. There is a bounded solution
- B. There is no solution
- C. There are infinite solutions
- D. None of the above

Answer: A

 [Watch Video Solution](#)

7. The region represented by the inequation system $x, y \geq 0, y \leq 6, x + y \leq 3$, is

- A. unbounded in first quadrant
- B. unbounded in first and second quadrants
- C. bounded in first quadrant
- D. None of the above

Answer: C



[Watch Video Solution](#)

8. A wholesale merchant wants to start the business of cereal with ₹ 24000. Wheat is ₹ 400 per quintal and rice is ₹ 600 per

quintal. He has capacity to store 200 quintal cereal. He earns the profit ₹ 25 per quintal on wheat and 40 per quintal on rice. If he stores x quintal rice and y quintal wheat, then for maximum profit the objective function is

A. $25x + 40y$

B. $40x = 25y$

C. $400x + 600y$

D. $\frac{400}{40}x + \frac{600}{25}y$

Answer: B



Watch Video Solution

9. Which of the term is not used in a linear programming problem? A) optimal solution B) Feasible solution C) concave

region D) objective functions

- A. Optimal solution
- B. Feasible solution
- C. Concave region
- D. objective functions

Answer: C



Watch Video Solution

10. If given constraints are $5x + 4y \geq 2$, $x \leq 6$, $y \leq 7$, then the maximum value of the function $z = x + 2y$ is

- A. 13
- B. 14

C. 15

D. 20

Answer: D



Watch Video Solution

11. $Z = 30x + 20y$,

$$x + y \leq 8, x + 2y \geq 4, 6x + 4 \geq 12, x \geq 0, y \geq 0$$

A. unique solution

B. infinitely many solution

C. minimum at (4, 0)

D. minimum 60 at point (0, 3)

Answer: B



[Watch Video Solution](#)

12. Minimize $Z = 3x + y$, subject to constraints

$2x + 3y \leq 6$, $x + y \geq 1$, $x \geq 0$, $y \geq 0$ Then

A. $x = 1, y = 1$

B. $x = 0, y = 1$

C. $x = 1, y = 0$

D. $x = -1, y = -1$

Answer: B



[Watch Video Solution](#)

13. The shaded region for the inequality $x + 5y \leq 6$ is

A. to the non-origin side of $x + 5y = 6$

B. to the either side of $x + 5y = 6$

C. to the origin side of $x + 5y = 6$

D. to the neither side of $x + 5y = 6$

Answer: C



Watch Video Solution