



BIOLOGY

BOOKS - TRUEMAN'S BIOLOGY (ENGLISH)

Genetics

Section A

1. Which Mendel's law of inheritance is universally acceptable and without any exception? State the law



[Watch Video Solution](#)

2. Name the parts 'A' and 'B' of the transcription unit given below.

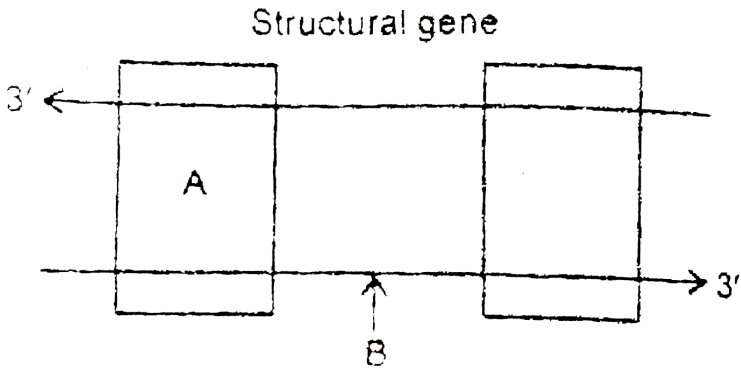

[▶ Watch Video Solution](#)

3. Name the components 'a' and 'b' in the nucleotide with a purine, given in the figure:

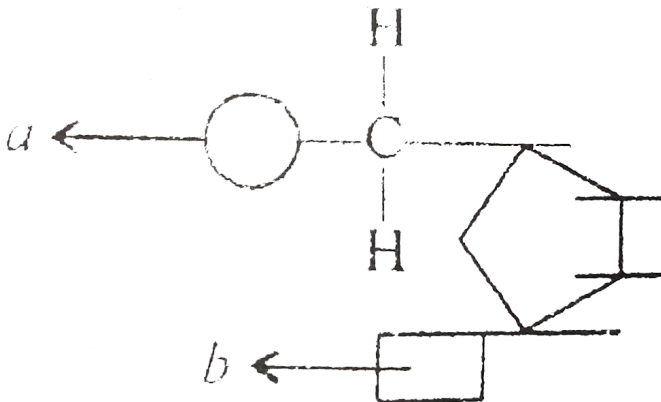



[Watch Video Solution](#)

4. Why hnRNA is required to undergo splicing?



[Watch Video Solution](#)

5. State any one reason to explain why RNA viruses mutate and evolve faster than other viruses



[Watch Video Solution](#)

6. How is the length of DNA usually calculated?



[Watch Video Solution](#)

7. How does HIV differ from bacteriophage?



[Watch Video Solution](#)

8. The gene I that controls the ABO blood grouping in human beings has three alleles I^A , I^B and i

(a) How many different genotypes are likely to be present in human population?

(b) Also, how many phenotypes are possibly present?

 [Watch Video Solution](#)

9. Provide one word or one sentence information about 'plasmid' with respect to its (i) chemical nature and (ii) its duplication.

 [Watch Video Solution](#)

10. Name the event during cell division that results in the gain or loss of chromosome.

 [Watch Video Solution](#)

11. Mention the contribution of genetic maps in human genome project.

 [Watch Video Solution](#)

12. Name one autosomal dominant and one autosomal recessive. Mendelian disorder in human.

 [Watch Video Solution](#)

13. A human being suffering from Down's Syndrome shows trisomy of 21st chromosome. Mention the cause of this chromosomal abnormality.

 [Watch Video Solution](#)

14. A pedigree chart given here, presents a particular generation which shows a trait irrespective of sexes (ie.. present in both male and female). Neither of the parents of the particular generation shows that trait. Draw

your conclusion on the basis of the pedigree.

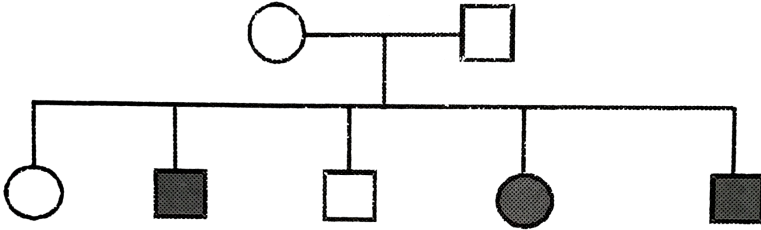

[Watch Video Solution](#)

15. In order to obtain the F_1 -generation Mendel pollinated a pure-breeding tall plant with a pure-breeding dwarf plant. But for getting the F_2 -generation, he simply self-pollinated the tall F_1 plants. Why?

[Watch Video Solution](#)

16. "Genes contain the information that is required to express a particular trait. Explain

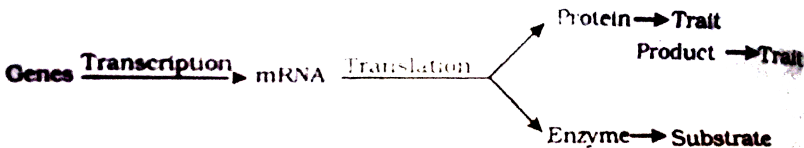

 [Watch Video Solution](#)

17. How are alleles of particular gene differ from each other? Explain its significance.

 [Watch Video Solution](#)

18. For the experssion of traits genes provide only the potentiality and the enivornment provides the opportunity. Comment on the veracity of the statement.

 [Watch Video Solution](#)

19. A, B, D are three independently assorting genes with their recessive aleles a,b,d respectively. A cross was made between individuals of Aa bb DD genotype with aa bb dd. Find out the type of genotypes of the offspring produced.

 [Watch Video Solution](#)

20. Sometimes cattle or even human beings give birth to their young ones that are having extremely different sets of organs like limb/position of eye(s) etc. Comment .

 [Watch Video Solution](#)

21. In a nucleus, the number of RNA nucleoside triphosphates is 10 times more than the number of DNA nucleoside triphosphates, still only DNA nucleotides are added during the DNA replication, and not the RNA nucleotides. Why?

 [Watch Video Solution](#)

22. Name the enzyme and state its property that is responsible for continuous and discontinuous replication of the two strands of a DNA molecule.

 [Watch Video Solution](#)

 Watch Video Solution

23. Pick out the ancestral line of Cycads from the list given below-Ferns, herbaceous lycopods, seed ferns, and horsetails

 Watch Video Solution

24. Mention the type of evolution that has brought the similarity as seen in potato tuber and sweet potato.

 Watch Video Solution

25.

| | | |
|---------|---|---|
| 1.5 mya | ↓ | Java man |
| 2 mya | ↓ | Homo habilis – more man like |
| | | Australopithecus – hunted with stones. |

Study the ladder of human evolution given above and answer the following questions.

- (i) Where did Australopithecus evolve?
- (ii) Write the scientific name of Java man?





[Watch Video Solution](#)

26. Coelacanth was caught in 1938 in South Africa. Why is it very significant in the evolutionary history of vertebrates?



[Watch Video Solution](#)

27. Name the common ancestor of the great apes and man.



[Watch Video Solution](#)

28. How do we compute the age of a fossils ?



[Watch Video Solution](#)

29. In a certain population, the frequency of three genotypes is as follows:



What is the likely frequency of B and b alleles?



[Watch Video Solution](#)

30. By what Latin name, the first Hominid was known?



[Watch Video Solution](#)

31. Among Ramapithecus, Australopithecines and Homo habilis who probably did not eat meat ?



[Watch Video Solution](#)

32. Write the formula to calculate allele frequency in future generations according to Hardy-Weinberg genetic equilibrium.



[Watch Video Solution](#)

33. Identify the examples of convergent evolution from the following :

- (i) Flippers of penguins and dolphins
- (ii) Eyes of octopus and mammals
- (iii) Vertebrate brains

 [Watch Video Solution](#)

34. Identify the examples of homologous structures from the following-

- (i) Vertebrate hearts
- (ii) Thorns in Bougainvillea and tendrils of Cucurbita.
- (iii) Food storage-organs in sweet potato and potato.

 [Watch Video Solution](#)

Section B

1. Given below is a sequence of steps of transcription in a eukaryotic cell. Fill up the blanks (1,2,3,4) left in the sequence .

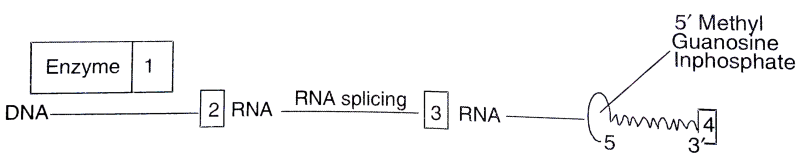

[▶ Watch Video Solution](#)

2. Study the figure given below and answer the questions:

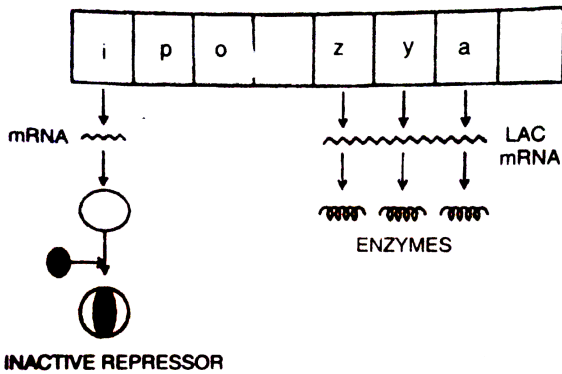

- (i) How does the repressor molecule get inactivated?
- (ii) When does the transcription of lac mRNA stop?
- (iii) Name the enzyme transcribed by the gene Z'.

[▶ Watch Video Solution](#)

3. Study the given portion of double stranded polynucleotide chain carefully. Identify a,b , c , and the 3' and 5' end of the chain

[▶ Watch Video Solution](#)

4. Answer the questions based on the dinucleotide shown below :

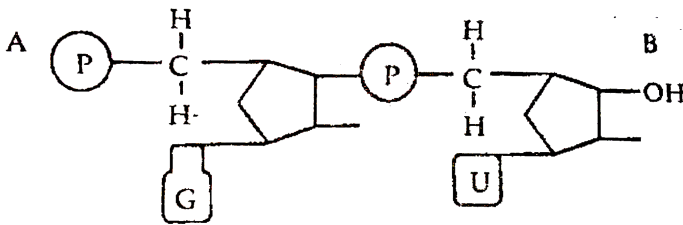

(i) Name the type of sugar guanine base is attached to ?

(ii) Name the linkage connecting the two nucleotides

(iii) Identify the 3' end of the dinucleotide. Given a reason for your answer.

[▶ Watch Video Solution](#)

5. How do histones acquire positive charge?

[▶ Watch Video Solution](#)

6. State the dual role of deoxyribonucleoside triphosphates during DNA replication.

 [Watch Video Solution](#)

7. Mention the role of ribosomes in peptide-bond formation. How does ATP facilitate it?

 [Watch Video Solution](#)

8. In a Mendelian monohybrid cross, the F_2 -generation shows identical genotypic and phenotypic ratios. What does it tell us about the nature of alleles involved? Justify your answer.

 [Watch Video Solution](#)

9. What is Down's syndrome? Give its symptoms and cause. Why is it that the chances of having a child with Down's syndrome increases if the age of the mother exceeds forty years ?



[Watch Video Solution](#)

10. What are the characteristic features of a true-breeding line?



[Watch Video Solution](#)

11. If a father and son are both defective in red-green colour vision, is it likely that the son inherited the trait from his father? Comment.



[Watch Video Solution](#)

12. What would happen if histones were to be mutated and made rich in acidic amino acids such as aspartic acid and glutamic acid in place of

basic amino acids such as lysine and arginine?

 [Watch Video Solution](#)

13. Recall the experiment done by Frederick Griffith. If RNA, instead of DNA was the genetic material, would the heat killed strain of strep have transformed the R-strain into virulent strain? Explain your answer.

 [Watch Video Solution](#)

14. You are repeating the Hershey-Chase experiment and are provided with two isotopes ^{32}P and ^{15}N (in place of ^{35}S in the original experiment). How do you expect your results to be different?

 [Watch Video Solution](#)

15. There is only one possible sequence of amino acids when deduced from a given nucleotides. But multiple nucleotides sequence can be

deduced from a single amino acid sequence. Explain this phenomena.



[Watch Video Solution](#)

16. A low level of expression of lac operon occurs at all the time. Can you explain the logic behind this phenomena.



[Watch Video Solution](#)

17. Would it be appropriate to use DNA probes such as VNTR in DNA fingerprinting of a bacteriophage?



[Watch Video Solution](#)

18. During in vitro synthesis of DNA, a researcher used 2. 3' dideoxy cytidine triphosphate as raw nucleotide in place of 2 deoxy cytidine triphosphate, other conditions remaining as standard. will further polymerisation of DNA continue upto the end or not? Explain.



[Watch Video Solution](#)

19. What background information did Watson and Crick have made available for developing a model of DNA ? What was their contribution ?



[Watch Video Solution](#)

20. What are the functions of

(i) methylated guanine cap?

(ii) poly-A 'tail' in a mature on RNA ?



[Watch Video Solution](#)

21. Do you think that the alternate splicing of exons may enable a structural gene to code for several isoproteins from one and the same gene? If yes, how? If not, why so ?



[Watch Video Solution](#)

22. Comment on the utility of variability in number of tansem repeats during DNA fingerprinting .



Watch Video Solution

23. Write the full of VNTR. How is VNTR different from 'Probe' ?



Watch Video Solution

24. A non-haemophilic couple was infomed by their doctor that there is possibility of a haemophilic child being born to them .Draw a checker board and find out the percentage of possibility of such a child among the progeny.



Watch Video Solution

25. In a particular plant species majority of the plants bear purple flowers. Very few plants bear white flowers. No intermediate colours are observed. If you are given a plant bearing purple flowers, how would you ascertain that it is a pure breed for that trait? Explain.

 [Watch Video Solution](#)

26. A cross between a red flower bearing plant and a white flower bearing plant of *Antirrhinum* produced all plants having pink flowers. Work out a cross to explain how this is possible.

 [Watch Video Solution](#)

27. In a typical monohybrid cross the F_2 -population ratio is written as 3 : 1 for phenotype but expressed as 1 : 2 : 1 for genotype. Explain with the help of an example.

 [Watch Video Solution](#)

28. Work out a cross to find the genotype of a tall pea plant. Name the type of cross.



Watch Video Solution

29. (a) Write the specific features of the genetic code AUG

(b) Explain aminoacylation of the tRNA



Watch Video Solution

30. Arrange the following groups of plants in an ascending evolutionary scale: Cycads: Rhynia-like plants: Chlorophyta ancestors: Dicotyledons, and Seed ferns. (in proper sequence)



Watch Video Solution

31. While creation and presence of variation is directionless, natural selection is directional as it is in the context of adaptation. Comment.

 [Watch Video Solution](#)

32. Gene flow occurs through generations. Gene flow can occur across language barriers in humans. If we have a technique of measuring specific allele frequencies in different population of the world, can we not predict human migratory patterns in pre-history and history ? Do you agree or disagree ? Provide explanation to your answer.

 [Watch Video Solution](#)

33. When we say ' survival of the fittest ' , does it mean that

(a) those which are fit only survive

(b) those that survive are called fit? Comment.

 [Watch Video Solution](#)

34. Enumerate three most characteristic criteria for designating a Mendelian population.

 [Watch Video Solution](#)

35. Migration may enhance or blurr the effects of selection' comment.

 [Watch Video Solution](#)

36. How do darwin' s finches illustrate adaptive radiation ?

 [Watch Video Solution](#)

37. List the two main propositions of Oparin and Haldane.

 [Watch Video Solution](#)

38. Write the Oparin and Haldane hypothesis about the origin of life on Earth. How does meteorite analysis favour this hypothesis?



Watch Video Solution

Section C

1. (i) What does this diagrammatic sketch depict?

(ii) Identify 'a' and 'b'

(iii) Name the widely used diagnostic test when a person gets this

disease.

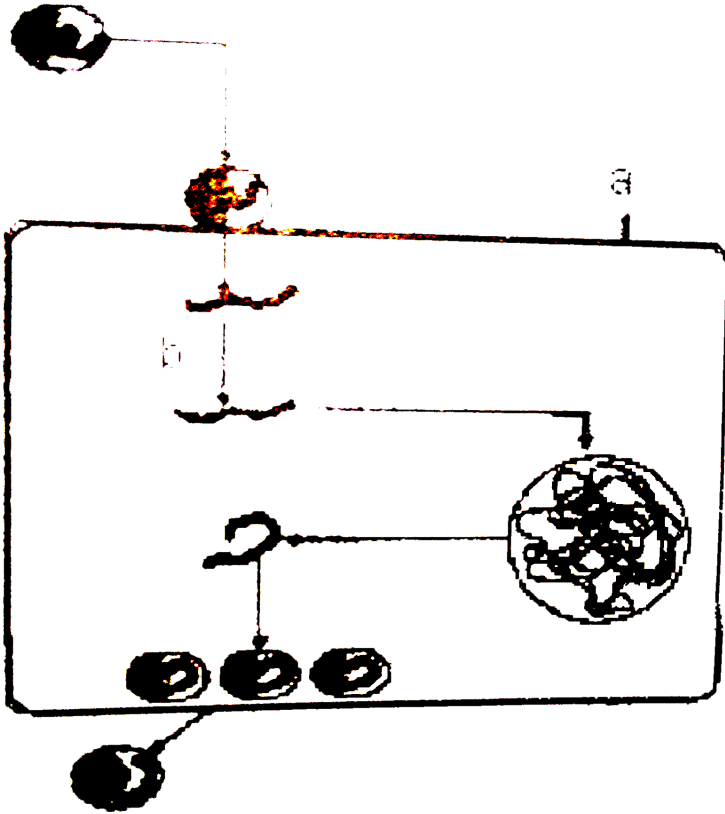

[▶ Watch Video Solution](#)

2. A 3' _____ 5' B

C 5' _____ 3' D

AB and CD represent two strands of a DNA molecule. When this molecule undergoes replication, forming a replication fork between A and C in the

above.

- (i) Name the template strands for replication.
- (ii) Using which strand as the template, will there be continuous synthesis of a complementary DNA strand?
- (iii) Complementary to which strand will Okazaki segments get synthesised and discontinuous synthesis will occur?
- (iv) What are template strands and Okazaki pieces?
- (v) In which direction is a new strand synthesized?



[Watch Video Solution](#)

3. In the following diagram the two DNA strands represented are ready for transcription

- (i) Label the parts marked 1 to 4
- (ii) Which one of the two strands of DNA has nucleotide sequence similar

to the mRNA that will be transcribed and why ?

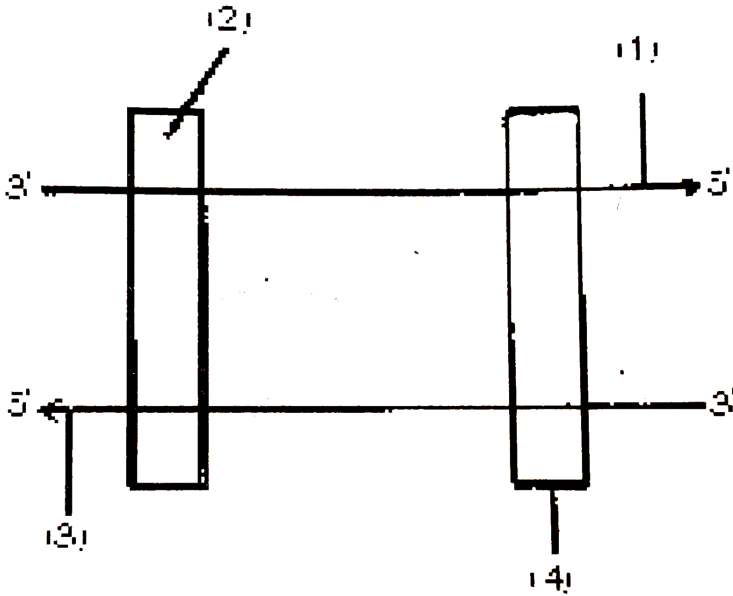

[Watch Video Solution](#)

4. What are types of sex-linkage?



[Watch Video Solution](#)

5. A non-haemophilic couple was informed by their doctor that there is possibility of a haemophilic child be born to them. Explain the basis on

which the doctor conveyed this information. Give the genotypes and the phenotypes of all the possible children who could be born to them.

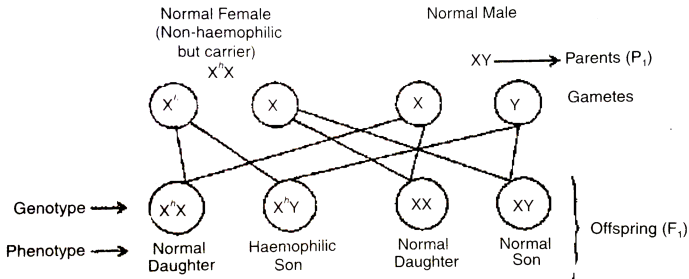

When the female human is non-haemophilic but carrier and male is non-haemophilic; they may have a haemophilic child.

[▶ Watch Video Solution](#)

6. What is 'semi- conservative' DNA replication ? How was it experimentally proved and by whom ?

[▶ Watch Video Solution](#)

7. A homozygous tall pea plant with green seeds is crossed with a dwarf pea plant with yellow seeds.

(i) What would be the phenotype and genotype of f_1 ?

(ii) Work out the phenotypic ratio of F_2 generation with the help of a punnet square.

 **Watch Video Solution**

8. Haemophilia is a sex linked recessive disorder of humans. The pedigree chart given below shows the inheritance of Haemophilia in one family. Study the pattern of inheritance and answer the questions given.

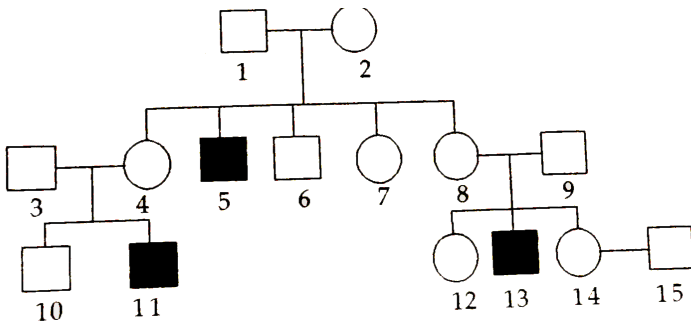

(a) Give all the possible genotypes of the members 4, 5 and 6 in the pedigree chart.

(b) A blood test shows that the individual 14 is a carrier of gaemophilia. The member numbered 15 has recently married the member numbered 14. What is the probability that their first child will be a haemophilic male ? Show with the help of Punnett square.



[Watch Video Solution](#)

9. Inheritance pattern of ABO blood groups in humans shows dominance, codominance and multiple allelism. Explain each concept with help of blood group genotypes.



[Watch Video Solution](#)

10. (a) What is this diagram representing?

(b) Name the parts a, b and c.

(c) In the eukaryotes the DNA molecules are organized within the nucleus.

How is the DNA molecule organized in a bacterial cell in absence of a

nucleus?

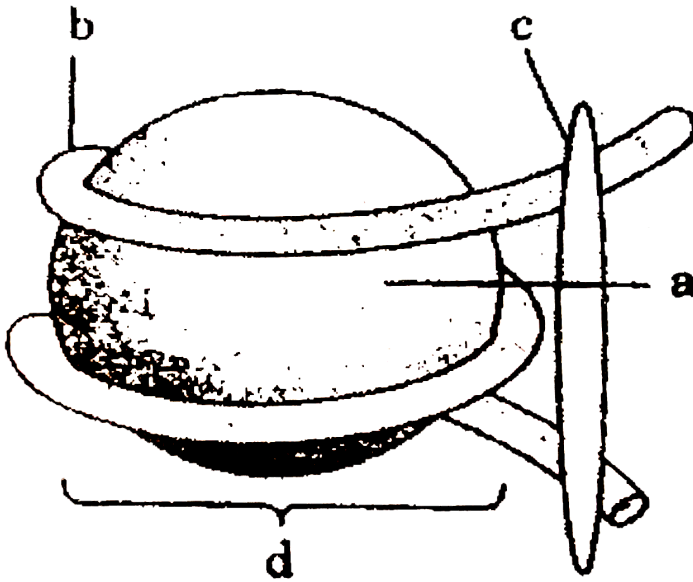

[Watch Video Solution](#)

11. (a) In human genome which one of the chromosomes has the most genes and which one has the fewest?

(b) Scientists have identified about 1.4 million single nucleotide polymorphs in human genome. How is the information of their existence going to help the scientists?

[Watch Video Solution](#)

12. Study the pedigree chart given, showing the Inheritance pattern of blood groups in a family and answer the following questions

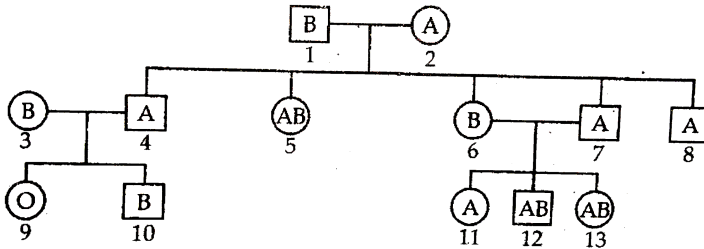

- Give the possible genotypes of the individuals 1 and 2.
- Which antigen or antigens will be present on the plasma membranes of the RBC's of individuals 5 and 9.
- Give the genotypes of the individuals 3 and 4.

[▶ Watch Video Solution](#)

13. Why are F_2 phenotypic and genotypic ratios same in a cross between red- flowered snapdragon and white-flowered snapdragon plants. Explain with the help of a cross.

[▶ Watch Video Solution](#)

14. (i) Why are grasshopper and *Drosophila* said to show male heterogamy? Explain.

(ii) Explain female heterogamy with the help of an example.

 [Watch Video Solution](#)

15. Why is tRNA called an adapter molecule?

 [Watch Video Solution](#)

16. (i) List the chromosomal disorders a human may suffer from if karyotype analysis of the individual shows 47 chromosomes instead of normal 46

(ii) Explain the cause that results in the gain of chromosome number.

(iii) Mention the symptoms of any one the disorders an individual can suffer from

 [Watch Video Solution](#)

17. How are dominance, codominance and incomplete dominance patterns of inheritance different from each other?



[Watch Video Solution](#)

18. A pea plant with purple flowers was crossed with white flowers producing all 50 plants with only purple flowers. On selfing, these plants produced 482 plants with purple flowers and 162 with white flowers. What genetic mechanism accounts for these results? Explain.



[Watch Video Solution](#)

19. (i) Name the enzyme that catalysis the transcription of hnRNA.

(ii) Why does the hnRNA need to undergo changes?

(iii) List the changes hnRNA undergoes and where in the cell such changes take place?





[Watch Video Solution](#)

20. Unambiguous, universal and degenerate are some of the terms used for the genetic code. Explain the salient features of each one of them.



[Watch Video Solution](#)

21. (a) Name the scientist who called t-RNA an adapter molecule.

(b) Draw a clover leaf structure of t-RNA showing the following:

(i) tyrosine attached to its amino acid site

(ii) anticodon for this amino acid in its correct site (codon for tyrosine is UAC)

(c) What does the actual structure of t-RNA look like?



[Watch Video Solution](#)

22. During the studies on genes in *Drosophila* that were sex-linked T.H. Morgan found F₂-population phenotypic ratios deviated from expected 9

: 3 : 3 : 1. Explain the conclusion he arrived at.



[Watch Video Solution](#)

23. Explain the mechanism of sex determination in insects like *Drosophila* and grasshopper.



[Watch Video Solution](#)

24. Who determines the sex of an unborn child? Mention whether temperature has a role in sex determination.



[Watch Video Solution](#)

25. The following is the flow chart highlighting the steps in DNA fingerprinting technique. Identify a, b, c, d, e and f.

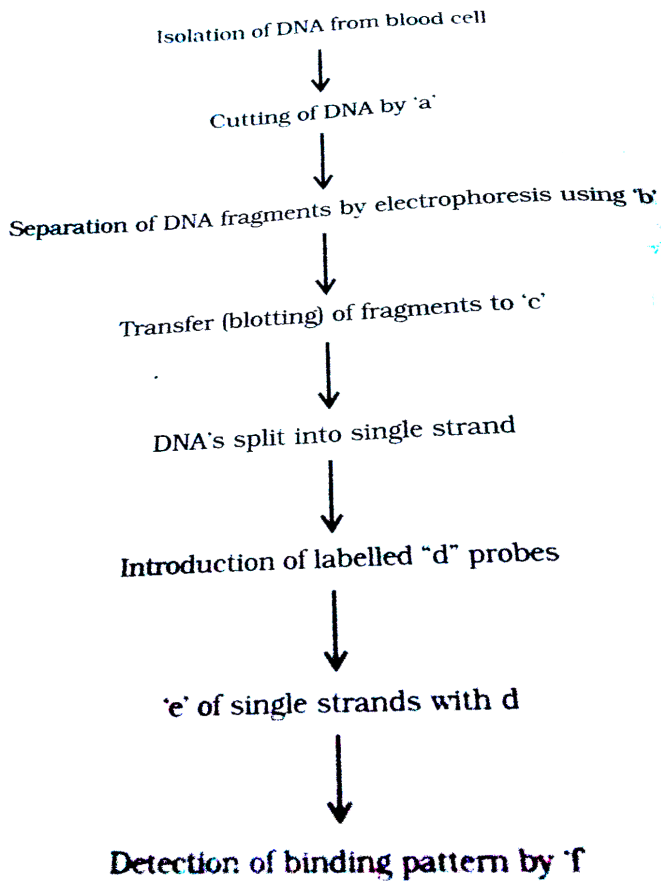

[Watch Video Solution](#)

26. Study the given pedigree chart showing the pattern of blood group inheritance in a family

(a) Given the genotype of the following:

(i) Parents

(ii) The individual 'X' in second generation

(b) State the possible blood groups of the individual 'Y' in third generation

(c) How does the inheritance of this blood group explain codominance?

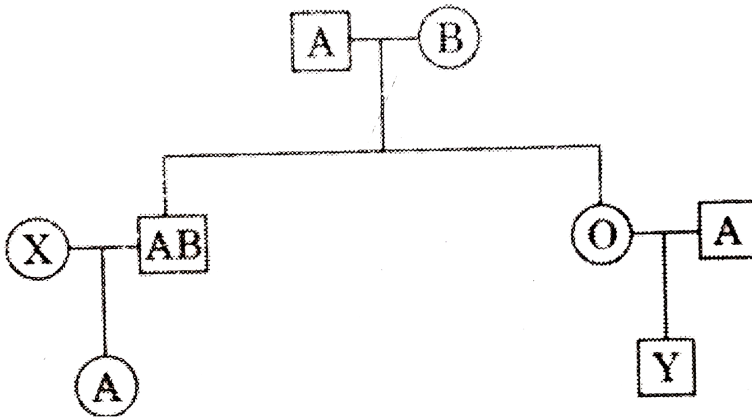

[Watch Video Solution](#)

27. a) Construct a complete transcription unit with promoter and terminator on the basis of hypothetical template strand given below



(b) Write the RNA strand transcribed from the above transcription unit along with its polarity



[Watch Video Solution](#)

28. What is the genetic basis for proof that codon is a triplet?



[Watch Video Solution](#)

29. What are Satellite DNA in a genome? Explain their role in DNA fingerprinting.



[Watch Video Solution](#)

30. Describe the structure of an RNA polynucleotide chain having four different types of nucleotides.

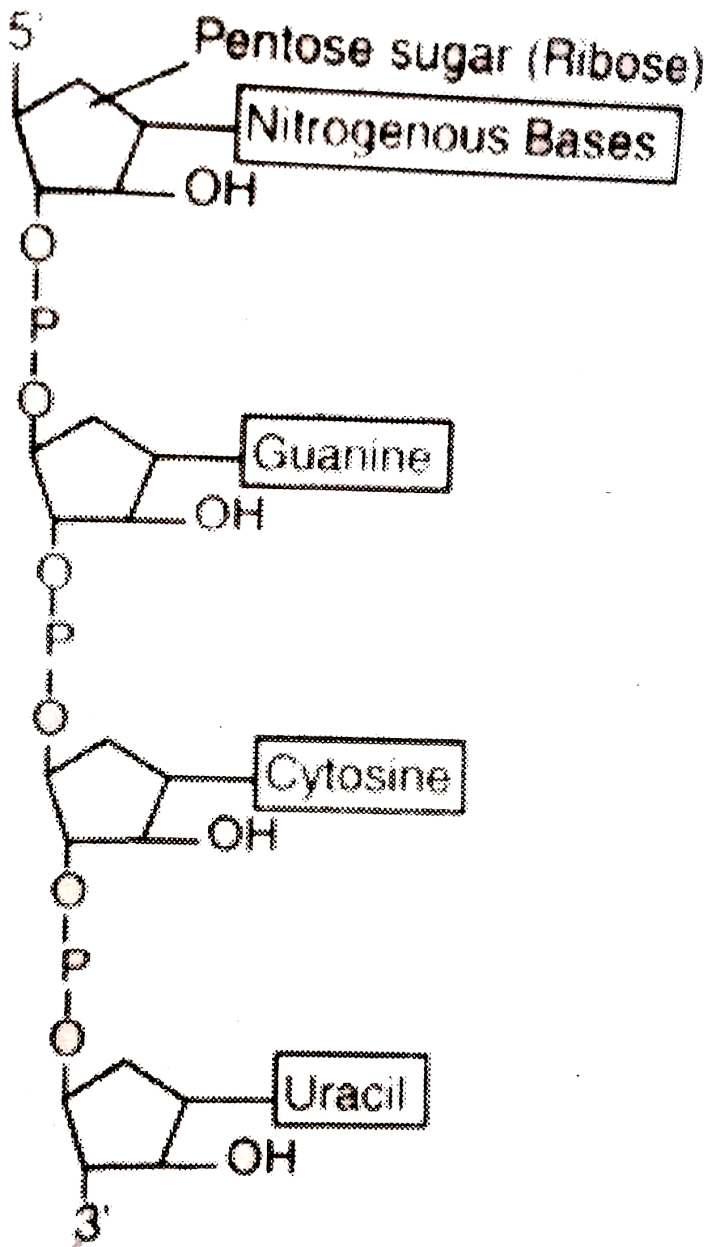

Watch Video Solution

31. Why are human females rarely haemophilic? Explain. How do haemophilic patients suffer?



Watch Video Solution

32. In a maternity clinic, for some reasons the authorities are not able to hand over the two new-borns to their respective real parents. Name and describe the technique that you would suggest to sort out the matter.



Watch Video Solution

33. a) Explain DNA polymorphism as the basis of genetic mapping of human genome.

b) State the role of VNTR in DNA fingerprinting.



Watch Video Solution

34. Explain codominance taking an example of human blood groups in the population.



Watch Video Solution

35. (a) State Hardy Weinberg principle. Name any two factors which affect it.

(b) Draw a graph to show that natural selection leads to directional change.



Watch Video Solution

36. "A population has been exhibiting genetic equilibrium". Answer the following with regard to the above statement.

(i) Explain the above statement.

(ii) Name the underlying principle.

(iii) List any two factors which would upset the genetic equilibrium of the population.

(iv) Take up any one such factor and explain how the gene pool will change due to that factor

 [Watch Video Solution](#)

37. In the 1950s, there were hardly any mosquitoes in Delhi. The use of the pesticide DDT on standing water killed their larvae. It is believed that now there are mosquitoes because they evolved DDT resistance through the interaction of mutation and Natural Selection. Pointwise, state in a sequence how that could have happened.

 [Watch Video Solution](#)

38. Discovery of Lobe-fins is considered very significant by evolutionary biologists. Explain.

 [Watch Video Solution](#)

39. Study the figure and answer the following



(a) Write your observations on the variations seen in the Darwin's finches shown above .

(b) How did Darwin explain the existence of different varieties of finches on Galapagos Islands ?

[▶ Watch Video Solution](#)

40. (a) Rearrange the following in an ascending order of evolutionary tree: Reptiles, salamander, lobe fins and frogs (b) Name two reproductive characters that probably make reptiles more successful than amphibians.

[▶ Watch Video Solution](#)

41. (a) What is adaptive radiation.

(b) Explain with the help of suitable example where adaptive radiation has occurred to represent convergent evolution.



Watch Video Solution

42. Study the figures below and answer the following :

(a) Mention the specific geographical region where these organisms are found.

(b) Name and explain the phenomenon that has resulted in the evolution of such diverse species in the region.

(c) Explain giving reasons the existence of placental wolf and Tasmanian

wolf sharing the same habitat.

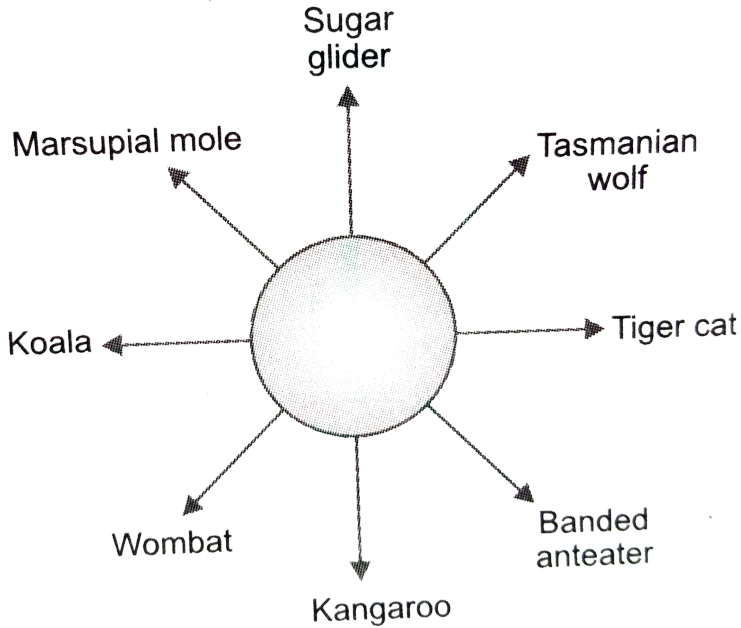

[Watch Video Solution](#)

43. Branching descent and natural selection are the two key concepts of Darwinian Theory of Evolution. Explain each concept with the help of a suitable example.



[Watch Video Solution](#)

44. With the help of any two suitable examples explain the effect of anthropogenic actions on organic evolution.



[Watch Video Solution](#)

45. Explain the increases in the numbers of melanic (dark winged) moths in the urban areas of post-industrialisation period in England.



[Watch Video Solution](#)

Section D

1. (a) Give reason for -

(i) Both strands of DNA are not copied during transcription.

(ii) Transcription and translation in bacteria can be coupled.

(b) Differentiate between the process of transcription in prokaryotes and eukaryotes



[Watch Video Solution](#)

2. Study the following carefully and explain why mutation (A) did not cause any sickle cell anemia in spite of change in the molecular structure of the gene which codes for Haemoglobin, when as a similar mutation (B) did. (The question is based on properties of the genetic code. c = codon, a = amino acid, Hb = Haemoglobin)

Codons for Hb: $C_1 - C_2 - C_3 - C_4 - C_5 - GAA - GAA - C_8 \dots$

Amino acids in Hb : $a_1 - a_2 - a_3 - a_4 - a_5$ - Glutamic acid- Glutamic acid
 $-a_8 \dots$ (Normal Haemoglobin)

Mutation (A) :

$C_1 - C_2 - C_3 - C_4 - C_5 - GAG - GAA - C_8 \dots a_1 - a_2 - a_3 - a_4 - a_5$
 $-a_8 \dots$ (Normal Haemoglobin)

Mutation (B) :

$C_1 - C_2 - C_3 - C_4 - C_5 - GAG - GAA - C_8 \dots a_1 - a_2 - a_3 - a_4 - a_5$
 $-a_8 \dots$ (Sickle cell Haemoglobin)

 View Text Solution

3. One chromosome contains one molecule of DNA. In eukaryotes the length of the DNA molecule is enormously large. Explain how such a long molecule fits into the tiny chromosomes seen at Metaphase.



[Watch Video Solution](#)

4. With the advent of DNA technology tool is available to identify a criminal or to the real parents. (a) Name this technique. (b) Write the missing steps in the procedure given below. Three of these steps are mentioned in the flow chart. (i) Extraction of DNA from the cells (ii)(iii) DNA is cut into fragments by restriction enzyme (iv) (v)..... (vi).(vii) Autoradiography



[Watch Video Solution](#)

5. (a) Explain Griffith's series of experiments where he witnessed transformation in bacteria he worked with.

(b) Name the scientists responsible for determining the biochemical

nature of "transforming principle" in Griffith's experiments. What did they prove?

 [Watch Video Solution](#)

6. Draw a labelled schematic structure of a transcription unit. Explain the function of each component of the unit in the process of transcription unit.

 [Watch Video Solution](#)

7. A snapdragon plant homozygous for red flower when crossed with a white flowered plant of the same species produced pink flowers in F_1 generation.

(a) What is the phenotypic expression called ?

(b) Work out the cross to show the F_2 generation when F_1 was self-pollinated. Give the phenotypic and genotypic ratios of f_2 generation.

(c) How do you compare the f_2 phenotypic and genotypic ratios with those of Mendelian monohybrid f_2 ?



[Watch Video Solution](#)

8. Two blood samples A and B picked up from the crime scene were handed over to the forensic department for genetic finger printing. Describe how the technique of genetic finger printing is carried out.



[Watch Video Solution](#)

9. How did Hershey and Chase proved that DNA is the hereditary material? Explain their experiment with suitable diagram.



[Watch Video Solution](#)

10. With the help of one example each provide genetic explanation for the following observations: brgt (i) F_1 -generation resembles both the parents.

F_1 -generation does not resemble either of the parents



[Watch Video Solution](#)

 Watch Video Solution

11. (i) How does a chromosomal disorder differ from a Mendelian disorder?
- (ii) Name any two chromosomal disorders.
- (iii) List the characteristics of the disorders mentioned above that help in their diagnosis.

 Watch Video Solution

12. Explain the causes, inheritance pattern and symptoms of any two Mendelian genetic disorders.

 Watch Video Solution

13. (a) Why is haemophilia generally observed in human males? Explain the conditions under which a human female can be haemophilic.
- (b) A pregnant human female was advised to undergo MTP. It was diagnosed by her doctor that the foetus she is carrying has developed

from a zygote formed by an XX-egg fertilized by Y-carrying sperm. Why was she advised to undergo MTP?

 [Watch Video Solution](#)

14. (a) State the central dogma in molecular biology. Who proposed it? Is it universally applicable? Explain.

(b) List any four properties of a molecule to be able to act as a genetic material

 [Watch Video Solution](#)

15. (a) Write what DNA replication refers to.

(b) State the properties of DNA replication model.

(c) List any three enzymes involved in the process along with their functions.

 [Watch Video Solution](#)

16. Inheritance patterns of flower colour in garden pea plant and snap dragon differ. Why is the difference observed? Explain the difference with the help of crosses in their inheritance patterns.

 [Watch Video Solution](#)

17. A child suffering from Thalassemia is born to a normal couple. But the mother is being blamed by the family for delivering a sick baby.

(a) What is Thalassemia ?

(b) How would you counsel the family not to blame the mother for delivering a child suffering from this disease ? Explain...

(c) List the values your counselling can propagate in the families.

 [Watch Video Solution](#)

18. a) Explain the mechanism of sex-determination in humans.

b) Differentiate between male heterogamety and female heterogamety with the help of an example of each.



[Watch Video Solution](#)

19. (a) Explain Mendel's law of independent assortment by taking a suitable example.

(b) How did Morgan show the deviation in inheritance pattern in *Drosophila* with respect to this law?



[Watch Video Solution](#)

20. Stanley Miller performed an experiment by recreating in the lab the probable conditions of the atmosphere of the primitive earth.

(i) What was the purpose of the experiment?

(ii) In what form was the energy supplied for the chemical reaction to occur?

(iii) Give a diagrammatic representation of Miller's experiment



[Watch Video Solution](#)

21. Explain the salient features of Hugo de Vries theory of mutation. How is Darwin's theory of natural selection different from it?

 [Watch Video Solution](#)

22. Fitness is the end result of the ability to adapt and get selected by Nature. Explain with suitable example.

 [Watch Video Solution](#)

23. The rate of appearance of new forms is linked to the life span of an organism. Explain with the help of a suitable example.

 [Watch Video Solution](#)

24. (a) Write the Hardy-Weinberg principle.

(b) Explain the three different ways in which natural selection can affect

the frequency of a heritable trait in a population shown in the graph given below.

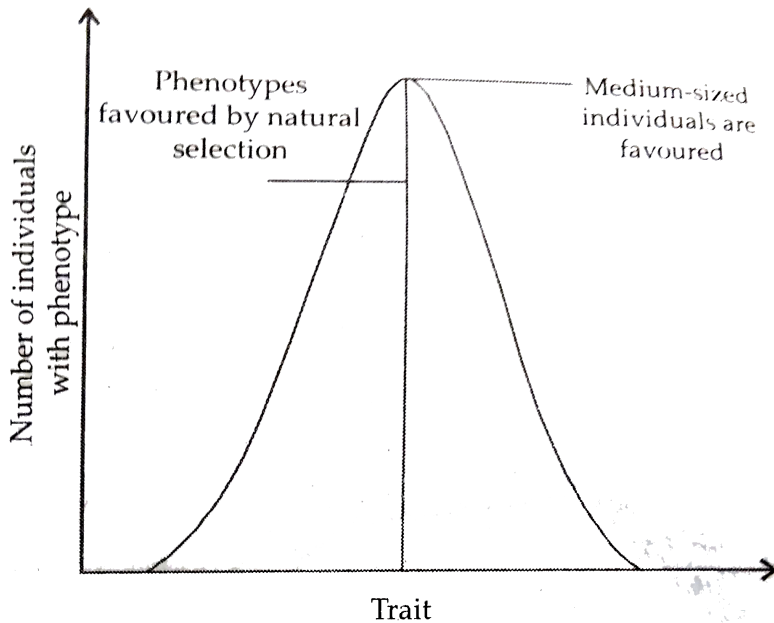

[Watch Video Solution](#)

25. How does the process of natural selection affect Hardy-Weinberg equilibrium? Explain List the other four factors that disturb the equilibrium.



[View Text Solution](#)

Assertion And Reason

1. [A]: The two members of a gene pair segregate from each other into the gametes.

[R]: During gametogenesis, the segregation of one gene pair is independent of other gene pair.

- A. If both A and R are true and R is the correct explanation of A
- B. If both A and R are true but R is not the correct explanation of A
- C. If A is true and R is false
- D. If both A and R are false

Answer: B



[Watch Video Solution](#)

2. [A]: Domestication is a type of plant breeding.

[R]: Selection is the basis for the improvement of crops through plant

breeding.

- A. If both A and R are true and R is the correct explanation of A
- B. If both A and R are true but R is not the correct explanation of A
- C. If A is true and R is false
- D. If both A and R are false

Answer: A

 [Watch Video Solution](#)

3. [A]: Erythroblastosis foetalis is a disease related with Rh factor and may cause death of foetus in the mother.

[R]: It causes massive destruction of foetal RBCs that leads to anaemia and tissue damage of foetus.

- A. If both A and R are true and R is the correct explanation of A
- B. If both A and R are true but R is not the correct explanation of A
- C. If A is true and R is false

D. If both A and R are false

Answer: A



[Watch Video Solution](#)

4. [A]: Genetic disorder, sickle cell anaemia is common in new born babies.

[R]: It is caused by heterozygosity for allele Hb^A , producing a single amino acid substitution in the α -chain of the Haemoglobin determined by allele Hb^A

A. If both A and R are true and R is the correct explanation of A

B. If both A and R are true but R is not the correct explanation of A

C. If A is true and R is false

D. If both A and R are false

Answer: C



[Watch Video Solution](#)

5. [A]: PKU is a autosomal recessive hereditary metabolic disease caused by the body's failure to oxidise an amino acid (Phenylalanine) to tyrosine because of a defective enzyme.

[R]: It result inthe presence of phenylpyruvic acid in the urine.

- A. If both A and R are true and R is the correct explanation of A
- B. If both A and R are true but R is not the correct explanation of A
- C. If A is true and R is false
- D. If both A and R are false

Answer: A



Watch Video Solution

6. [A]: Each gemete has only one allele for each trait.

[R]: It is true of single trait crosses only.

- A. If both A and R are true and R is the correct explanation of A

B. If both A and R are true but R is not the correct explanation of A

C. If A is true and R is false

D. If both A and R are false

Answer: C



Watch Video Solution

7. [A]: When doing genetics problems, first decide the appropriate key and then determine the genotype and gametes for both parents.

[R]: It is necessary to keep in mind that although an individual has two alleles for each trait, each gamete has only one allele for each trait

A. If both A and R are true and R is the correct explanation of A

B. If both A and R are true but R is not the correct explanation of A

C. If A is true and R is false

D. If both A and R are false

Answer: A



[Watch Video Solution](#)

8. [A]: Chromosomes are divided into hetero- chromatin and euchromatin part.

[R]: Heterochromatin are those regions of chromosome that remain condensed during interphase and early prophase, and rest of the non-condensed form of chromosome is called euchromatin

- A. If both A and R are true and R is the correct explanation of A
- B. If both A and R are true but R is not the correct explanation of A
- C. If A is true and R is false
- D. If both A and R are false

Answer: A



[Watch Video Solution](#)

9. [A]: Metacentric chromosomes are V-shaped.

[R]: In these chromosomes the centromere occurs in the centre and forming two equal arms.

- A. If both A and R are true and R is the correct explanation of A
- B. If both A and R are true but R is not the correct explanation of A
- C. If A is true and R is false
- D. If both A and R are false

Answer: A



[Watch Video Solution](#)

10. Assertion : Plasmids are double-stranded extra chromosomal DNA.

Reason : Plasmids are possessed by eukaryotic cells.

- A. If both A and R are true and R is the correct explanation of A
- B. If both A and R are true but R is not the correct explanation of A

C. If A is true and R is false

D. If both A and R are false

Answer: D



[Watch Video Solution](#)

11. [A]: Exchange of genetic material occurs during meiosis.

[R]: There is chiasma formation in meiosis.

A. If both A and R are true and R is the correct explanation of A

B. If both A and R are true but R is not the correct explanation of A

C. If A is true and R is false

D. If both A and R are false

Answer: A



[Watch Video Solution](#)

12. Assertion:XXX females are called super females

Reason : They often give birth to triplets and quadruplets

- A. If both A and R are true and R is the correct explanation of A
- B. If both A and R are true but R is not the correct explanation of A
- C. If A is true and R is false
- D. If both A and R are false

Answer: C



Watch Video Solution

13. [A]: A gene affecting the expression of an- other nonallelic gene is called epistatic gene.

[R]: Epistatic gene hides the expression of an allele at a different locus

- A. If both A and R are true and R is the correct explanation of A
- B. If both A and R are true but R is not the correct explanation of A

C. If A is true and R is false

D. If both A and R are false

Answer: A



[Watch Video Solution](#)

14. [A]: The sex linked genes are passed on to the grandson through the daughter.

[R]: The Y chromosome of the grandson is received from the maternal grandfather

A. If both A and R are true and R is the correct explanation of A

B. If both A and R are true but R is not the correct explanation of A

C. If A is true and R is false

D. If both A and R are false

Answer: C



[Watch Video Solution](#)

15. Assertion : Mutations are necessary for the survival of the species.

Reason : Lack of mutation gives a temporary advantage to a species in an unchanged environment.

- A. If both A and R are true and R is the correct explanation of A
- B. If both A and R are true but R is not the correct explanation of A
- C. If A is true and R is false
- D. If both A and R are false

Answer: A



Watch Video Solution

16. [A]: It is not possible to take photograph and count chromosomes when they are highly coiled and condensed.

[R]: Each species has a variable number of chromosomes.

- A. If both A and R are true and R is the correct explanation of A
- B. If both A and R are true but R is not the correct explanation of A
- C. If A is true and R is false
- D. If both A and R are false

Answer: D

 [Watch Video Solution](#)

17. [A]: Neurospora is an ideal genetic material for research.

[R]: Because of its suitability in the studies of genetics contained within it.

- A. If both A and R are true and R is the correct explanation of A
- B. If both A and R are true but R is not the correct explanation of A
- C. If A is true and R is false
- D. If both A and R are false

Answer: A



[Watch Video Solution](#)

18. [A]: Heterosis is superiority of F_1 hybrid over its two genetically dissimilar parents.

[R]: Heterosis can be measured in terms of size, yield and growth rate

- A. If both A and R are true and R is the correct explanation of A
- B. If both A and R are true but R is not the correct explanation of A
- C. If A is true and R is false
- D. If both A and R are false

Answer: B



[Watch Video Solution](#)

19. [A]: Mendelian recombinations are due to crossing over.

[R]: Crossing over brings about exchange of genes through chiasma formation.

- A. If both A and R are true and R is the correct explanation of A
- B. If both A and R are true but R is not the correct explanation of A
- C. If A is true and R is false
- D. If both A and R are false

Answer: A



[Watch Video Solution](#)

20. [A]: Genes confined to differential region of homologous chromosomes are called holandric genes.

[R]: Genes confined to homologous region of Y chromosomes only are called Holandric genes.

- A. If both A and R are true and R is the correct explanation of A
- B. If both A and R are true but R is not the correct explanation of A
- C. If A is true and R is false
- D. If both A and R are false

Answer: D

 [Watch Video Solution](#)

21. [A]: Chromosomes appear longer during te-lophase.

[R]: The term chromosome was coined by Waldeyer.

- A. If both A and R are true and R is the correct explanation of A
- B. If both A and R are true but R is not the correct explanation of A
- C. If A is true and R is false
- D. If both A and R are false

Answer: B

 [Watch Video Solution](#)

22. [A]: Copy choice theory for crossing over was proposed by Belling.

[R]: According to this theory, paired chromosomes in Meiosis I, duplicate their genes before the development of fibres that join them in tandem.

- A. If both A and R are true and R is the correct explanation of A
- B. If both A and R are true but R is not the correct explanation of A
- C. If A is true and R is false
- D. If both A and R are false

Answer: B

 [Watch Video Solution](#)

23. [A]: Kornberg and Ochoa got Nobel Prize in the field of genetics.

[R]: Because they proposed mutation Theory

- A. If both A and R are true and R is the correct explanation of A
- B. If both A and R are true but R is not the correct explanation of A
- C. If A is true and R is false
- D. If both A and R are false

Answer: C

 [Watch Video Solution](#)

24. Consider the following statements :

Assertion (A) : Amber codon is a termination codon .

Reason (R) : If in a m-RNA, a termination codon is present, the protein synthesis stops abruptly whether the protein synthesis is complete or not.

Now select you answer from code given below :

- A. If both A and R are true and R is the correct explanation of A
- B. If both A and R are true but R is not the correct explanation of A

C. If A is true and R is false

D. If both A and R are false

Answer: C



Watch Video Solution

25. [A]: DNA replicates after mitosis.

[R]: In mitosis, the chromosomal number does not stay constant

A. If both A and R are true and R is the correct explanation of A

B. If both A and R are true but R is not the correct explanation of A

C. If A is true and R is false

D. If both A and R are false

Answer: D



Watch Video Solution

26. [A]: DNA code is copied in the synthesis of m-RNA.

[R]: tRNA moves out of the nucleus and after attaching on ribosomes form the template

- A. If both A and R are true and R is the correct explanation of A
- B. If both A and R are true but R is not the correct explanation of A
- C. If A is true and R is false
- D. If both A and R are false

Answer: D



[Watch Video Solution](#)

27. [A]: DNA is associated with proteins.

[R]: DNA wound around histone proteins that form a pool and the entire structure is called nucleosome

- A. If both A and R are true and R is the correct explanation of A

B. If both A and R are true but R is not the correct explanation of A

C. If A is true and R is false

D. If both A and R are false

Answer: A



Watch Video Solution

28. [A]: Translocation involves transfer of genetic material between homologous chromosome.

[R]: Translocation involves duplication of genetic material causing chromosomal aberration during gametes formation.

A. If both A and R are true and R is the correct explanation of A

B. If both A and R are true but R is not the correct explanation of A

C. If A is true and R is false

D. If both A and R are false

Answer: D

 [Watch Video Solution](#)

29. Assertion : Left-handed DNA is known as B-DNA.

Reason : Right - handed DNA is known as Z-DNA .

- A. If both A and R are true and R is the correct explanation of A
- B. If both A and R are true but R is not the correct explanation of A
- C. If A is true and R is false
- D. If both A and R are false

Answer: D

 [Watch Video Solution](#)

30. [A]: Meselson and Stahl tested the Watson and Crick Theory of DNA replication.

[R]: They confirmed the mechanism of DNA replication by using the isotopic and Centrifugation technique

- A. If both A and R are true and R is the correct explanation of A
- B. If both A and R are true but R is not the correct explanation of A
- C. If A is true and R is false
- D. If both A and R are false

Answer: A



[Watch Video Solution](#)

31. Assertion (A) : Adenine cannot pair with cytosine.

Reason [®] : Because there would be two hydrogen atoms in one of the bonding and none at the other.

- A. If both A and R are true and R is the correct explanation of A
- B. If both A and R are true but R is not the correct explanation of A
- C. If A is true and R is false

D. If both A and R are false

Answer: A



[Watch Video Solution](#)

32. Assertion : DNA is associated with proteins.

Reason : DNA binds around histone proteins that form a pool and the entire structure is called a nucleosome.

A. If both A and R are true and R is the correct explanation of A

B. If both A and R are true but R is not the correct explanation of A

C. If A is true and R is false

D. If both A and R are false

Answer: A



[Watch Video Solution](#)

33. Assertion. The genetic code is degenerate.

Reason. Most amino acids are coded by more than one codon.

- A. If both A and R are true and R is the correct explanation of A
- B. If both A and R are true but R is not the correct explanation of A
- C. If A is true and R is false
- D. If both A and R are false

Answer: A



[Watch Video Solution](#)

34. Assertion A non-overlapping code means that a base in mRNA is not used for different codons

Reason In translating mRNA molecules, the codons do not overlap but are read sequentially

- A. If both A and R are true and R is the correct explanation of A
- B. If both A and R are true but R is not the correct explanation of A

C. If A is true and R is false

D. If both A and R are false

Answer: A



[Watch Video Solution](#)

35. [A]: Recombinant DNA contains DNA from two or more sources.

[R]: Plasmids are small extra rings of DNA in bacteria that carry genes not present in the bacterial chromosome

A. If both A and R are true and R is the correct explanation of A

B. If both A and R are true but R is not the correct explanation of A

C. If A is true and R is false

D. If both A and R are false

Answer: B



[Watch Video Solution](#)

36. [A]: Genetic engineering is the use of technology to alter the genome of a cell for the benefit of we people.

[R]: Here foreign gene is inserted into the cell to get desirable product.

- a) If both A and R are true and R is the correct explanation of A
- b) If both A and R are true but R is not the correct explanation of A
- c) If A is true and R is false
- d) If both A and R are false

A. If both A and R are true and R is the correct explanation of A

B. If both A and R are true but R is not the correct explanation of A

C. If A is true and R is false

D. If both A and R are false

Answer: A



Watch Video Solution

37. [A]: The Lac operon is an example of inducible system.

[R]: When Lactose, the inducer is present in the medium, it binds to the repressor making it ineffective.

- A. If both A and R are true and R is the correct explanation of A
- B. If both A and R are true but R is not the correct explanation of A
- C. If A is true and R is false
- D. If both A and R are false

Answer: A



[Watch Video Solution](#)

38. [A]: Vectors carry the foreign DNA/gene into the host cell.

[R]: Plasmids can carry recombinant DNA but viruses can not.

- A. If both A and R are true and R is the correct explanation of A
- B. If both A and R are true but R is not the correct explanation of A

C. If A is true and R is false

D. If both A and R are false

Answer: D



[Watch Video Solution](#)

39. [A]: The series of enzyme controlled reactions determine traits in an organism.

[R]: Since the structure of specific proteins (enzymes) is controlled by the genes and follows determination of traits

A. (a) If both A and R are true and R is the correct explanation of A

B. (b) If both A and R are true but R is not the correct explanation of A

C. (c) If A is true and R is false

D. (d) If both A and R are false

Answer: A



[Watch Video Solution](#)

40. [A]: Raphanobrassica is an excellent example of allotetraploidy.

[R]: It involves intergeneric cross between radish genus- Raphanus and cabbage genus- Brassica, each of which has a diploid chromosome number of 18.

- A. If both A and R are true and R is the correct explanation of A
- B. If both A and R are true but R is not the correct explanation of A
- C. If A is true and R is false
- D. If both A and R are false

Answer: A

41. [A]: Plasmids are double stranded extra chromosomal DNA.

[R]: Plasmids are found in Prokaryotic cells.

- A. If both A and R are true and R is the correct explanation of A
- B. If both A and R are true but R is not the correct explanation of A
- C. If A is true and R is false
- D. If both A and R are false

Answer: B

 [Watch Video Solution](#)

42. Assertion (A) : Adenine cannot pair with cytosine.

Reason [®] : Because there would be two hydrogen atoms in one of the bonding and none at the other.

- A. If both A and R are true and R is the correct explanation of A
- B. If both A and R are true but R is not the correct explanation of A
- C. If A is true and R is false
- D. If both A and R are false

Answer: B



[Watch Video Solution](#)

43. [A]: The base ratio $(A+T)/(G+C)$ is constant in a particular organism.

[R]: The ratio is, however, different in the different DNA molecules

- A. If both A and R are true and R is the correct explanation of A
- B. If both A and R are true but R is not the correct explanation of A
- C. If A is true and R is false
- D. If both A and R are false

Answer: A



[Watch Video Solution](#)

44. [A]: *Drosophila* is commonly used in the study of genetics.

[R]: Because it is very small and its life cycle is short.

- A. If both A and R are true and R is the correct explanation of A
- B. If both A and R are true but R is not the correct explanation of A
- C. If A is true and R is false
- D. If both A and R are false

Answer: A

 [Watch Video Solution](#)

45. [A]: When RH positive male marries RH negative woman the situation can be serious.

[R]: Genes linked to homologous part of X and Y chromosome behaves as autosomal genes.

- A. If both A and R are true and R is the correct explanation of A
- B. If both A and R are true but R is not the correct explanation of A
- C. If A is true and R is false
- D. If both A and R are false

Answer: B



[Watch Video Solution](#)

46. [A]: Hershey and Chase experiment showed that protein is the genetic material of T_2 bacteriophage.

[R]: According to Hershey and Chase, RNA is the genetic material in T_2 bacteriophage.

- A. If both A and R are true and R is the correct explanation of A
- B. If both A and R are true but R is not the correct explanation of A
- C. If A is true and R is false
- D. If both A and R are false

Answer: D



[Watch Video Solution](#)

47. [A]: The DNA fingerprinting relies on recombinant DNA technology and can prove the identification of a suspect.

[R]: It is based on the pattern, length, and number of DNA repeats and are unique for each individual's genetic blueprint-DNA

- a) If both A and R are true and R is the correct explanation of A
- b) If both A and R are true but R is not the correct explanation of A
- c) If A is true and R is false
- d) If both A and R are false

A. If both A and R are true and R is the correct explanation of A

B. If both A and R are true but R is not the correct explanation of A

C. If A is true and R is false

D. If both A and R are false

Answer: A



Watch Video Solution

48. [A]: Chromatid is one of a pair of replicated chromosomes found during the prophase and metaphase stages of mitosis and meiosis.

[R]: Chromatin is classified as euchromatin or heterochromatin on the basis of staining properties. Euchromatin is thought to be actively involved in transcription and, therefore, protein synthesis, while heterochromatin is inactive.

- A. If both A and R are true and R is the correct explanation of A
- B. If both A and R are true but R is not the correct explanation of A
- C. If A is true and R is false
- D. If both A and R are false

Answer: B



[Watch Video Solution](#)

49. [A]: For a recipient to receive blood from a donor, the recipient's plasma must not have an antibody that causes the donor's cell to

agglutinate.

[R]: The possibility of blood clumping does not depend on anti-A or anti-B antibody and blood type

- A. If both A and R are true and R is the correct explanation of A
- B. If both A and R are true but R is not the correct explanation of A
- C. If A is true and R is false
- D. If both A and R are false

Answer: C



[Watch Video Solution](#)

50. [A]: Lampbrush chromosomes are found in the oocytes of certain animals during the prophase of meiosis. Such chromosomes consist of two central strands along which fine loops extend laterally.

[R]: The loops are thought to be active regions of RNA synthesis

- A. If both A and R are true and R is the correct explanation of A

B. If both A and R are true but R is not the correct explanation of A

C. If A is true and R is false

D. If both A and R are false

Answer: B



Watch Video Solution

51. Assertion (a) : Supernumerary chromosomes do not usually have any effect on the phenotype and Hence ,are genetically unnecessary.

Reason(R) : In some plants supernumerary chromosomes result in decreased vigour.

A. If both A and R are true and R is the correct explanation of A

B. If both A and R are true but R is not the correct explanation of A

C. If A is true and R is false

D. If both A and R are false

Answer: B



[Watch Video Solution](#)

52. [A]: The chromosomes of plants are larger than animals.

[R]: The chromosomes of monocots are larger than dicots

- A. If both A and R are true and R is the correct explanation of A
- B. If both A and R are true but R is not the correct explanation of A
- C. If A is true and R is false
- D. If both A and R are false

Answer: B



[Watch Video Solution](#)

53. [A]: Metacentric chromosomes are V- shaped.

[R]: In these chromosomes the centromere occurs in the centre and

forming two equal arms.

- A. If both A and R are true and R is the correct explanation of A
- B. If both A and R are true but R is not the correct explanation of A
- C. If A is true and R is false
- D. If both A and R are false

Answer: A



[Watch Video Solution](#)

54. [A]: Chromosomes are divided into heterochromatin and euchromatin part.

[R]: Heterochromatin are those regions of chromosome that remain condensed during interphase and early prophase, and rest of the non-condensed form of chromosome is called euchromatin

- a. If both A and R are true and R is the correct explanation of A
- b. If both A and R are true but R is not the correct explanation of A

c. If A is true and R is false

d. If both A and R are false

A. a. If both A and R are true and R is the correct explanation of A

B. If both A and R are true but R is not the correct explanation of A

C. If A is true and R is false

D. If both A and R are false

Answer: A



Watch Video Solution

55. [A]: Triplet code is a degenerate one.

[R]: Explanation for degeneracy is provided by Wobble hypothesis

A. (a) If both A and R are true and R is the correct explanation of A

B. (b) If both A and R are true but R is not the correct explanation of A

C. (c) If A is true and R is false

D. (d) If both A and R are false

Answer: A



[Watch Video Solution](#)

56. Assertion : Identical twins are produced during two births , resulting from the division of a single fertilized egg .

Reason : They are of the different sex and otherwise genetically identical.

A. If both A and R are true and R is the correct explanation of A

B. If both A and R are true but R is not the correct explanation of A

C. If A is true and R is false

D. If both A and R are false

Answer: D



[Watch Video Solution](#)

57. [A]: Genetic engineering is the use of technology to alter the genome of living cell for medical or industrial use.

[R]: Biotechnology gave rise to an industry that provides products made by genetic engineering of bacteria.

- A. If both A and R are true and R is the correct explanation of A
- B. If both A and R are true but R is not the correct explanation of A
- C. If A is true and R is false
- D. If both A and R are false

Answer: A

 [Watch Video Solution](#)

58. [A]: Polymerase chain reaction (PCR) followed by DNA probe is used during DNA finger printing.

[R]: A DNA finger print is inherited and, therefore, resembles that of parent

- A. If both A and R are true and R is the correct explanation of A
- B. If both A and R are true but R is not the correct explanation of A
- C. If A is true and R is false
- D. If both A and R are false

Answer: B

 [Watch Video Solution](#)

59. [A]: The preparation of recombinant DNA requires restriction enzymes.

[R]: Because these are not used to cleave plasmid DNA

- A. If both A and R are true and R is the correct explanation of A
- B. If both A and R are true but R is not the correct explanation of A
- C. If A is true and R is false
- D. If both A and R are false

Answer: C



Watch Video Solution

60. [A]: Plasmids are small accessory rings of DNA found in some bacteria that carry genes.

[R]: Plasmids that are used as a vector have been removed from bacteria and have had a foreign gene inserted into them

- A. If both A and R are true and R is the correct explanation of A
- B. If both A and R are true but R is not the correct explanation of A
- C. If A is true and R is false
- D. If both A and R are false

Answer: A



Watch Video Solution

61. [A]: Proteins are polymers of amino acids.

[R]: Nucleic acids are polymers of units known as nucleotides

- A. If both A and R are true and R is the correct explanation of A
- B. If both A and R are true but R is not the correct explanation of A
- C. If A is true and R is false
- D. If both A and R are false

Answer: B



[Watch Video Solution](#)

62. [A]: Prokaryotic cells do not contain repressor protein

[R]: They do not function as genetic valves by combining with specific genes to turn on their activity.

- A. If both A and R are true and R is the correct explanation of A
- B. If both A and R are true but R is not the correct explanation of A

C. If A is true and R is false

D. If both A and R are false

Answer: D



[Watch Video Solution](#)

63. [A]: If a population is of dominant genotype AA, then the frequency of dominant alleles in the gene pool will be relatively higher.

[R]: The percentage of gametes bearing recessive (aa) allele will be correspondingly low

A. If both A and R are true and R is the correct explanation of A

B. If both A and R are true but R is not the correct explanation of A

C. If A is true and R is false

D. If both A and R are false

Answer: A



[Watch Video Solution](#)

64. [A]: In paracentric inversions the centromere is outside the inverted segment.

[R]: In pericentric inversion, the inverted segment includes the centromere

- A. If both A and R are true and R is the correct explanation of A
- B. If both A and R are true but R is not the correct explanation of A
- C. If A is true and R is false
- D. If both A and R are false

Answer: B



Watch Video Solution

65. [A]: Polyploidy increases the tolerance of plants towards extreme climates.

[R]: Autopolyploids produce seed less fruits.

- A. If both A and R are true and R is the correct explanation of A
- B. If both A and R are true but R is not the correct explanation of A
- C. If A is true and R is false
- D. If both A and R are false

Answer: B



[Watch Video Solution](#)

66. [A]: Haemophilia is a genetically linked disease.

[R]: The carrier gene is present on X chromosome of female

- A. If both A and R are true and R is the correct explanation of A
- B. If both A and R are true but R is not the correct explanation of A
- C. If A is true and R is false
- D. If both A and R are false

Answer: A



[Watch Video Solution](#)

67. [A]: Cytoplasmic male sterility is observed in maize.

[R]: The cytoplasmic male sterility in maize is due to interaction of cytoplasmic factors and male sterile gene

- A. If both A and R are true and R is the correct explanation of A
- B. If both A and R are true but R is not the correct explanation of A
- C. If A is true and R is false
- D. If both A and R are false

Answer: A



[Watch Video Solution](#)

68. Assertion: DNA synthesis occurs in G_1 and G_2 periods of cell cycle.

Reason: During G_1 and G_2 phase the DNA contents become double.

- A. If both A and R are true and R is the correct explanation of A
- B. If both A and R are true but R is not the correct explanation of A
- C. If A is true and R is false
- D. If both A and R are false

Answer: D



[Watch Video Solution](#)

69. [A]: Sickle-cell anaemia is a genetically determined disorder affecting many new born babies.

[R]: It is caused by heterozygosity for allele Hb^c , producing a single amino acid substitution in the α -chain of the normal haemoglobin molecule determined by allele Hb^A .

- A. If both A and R are true and R is the correct explanation of A
- B. If both A and R are true but R is not the correct explanation of A
- C. If A is true and R is false
- D. If both A and R are false

Answer: C

 [Watch Video Solution](#)

70. [A]: The deleted region of long arm of chromosome 7 contains the elastin gene.

[R]: Deletion of long arm of chromosome 7 results in Cri du Chat syndrome

- A. If both A and R are true and R is the correct explanation of A
- B. If both A and R are true but R is not the correct explanation of A
- C. If A is true and R is false
- D. If both A and R are false

Answer: C



Watch Video Solution

71. [A]: Centromere is the primary constriction on the metaphase chromosome.

[R]: It helps to separate sister chromatids

- A. (a) If both A and R are true and R is the correct explanation of A
- B. (b) If both A and R are true but R is not the correct explanation of A
- C. (c) If A is true and R is false
- D. (d) If both A and R are false

Answer: B



Watch Video Solution

72. [A]: Dolly, a sheep is an example of cloning.

[R]: Cloning in another sense is sexual reproduction.

- A. If both A and R are true and R is the correct explanation of A
- B. If both A and R are true but R is not the correct explanation of A
- C. If A is true and R is false
- D. If both A and R are false

Answer: B



[Watch Video Solution](#)

73. Assertion (A) : Replication and transcription occur in the nucleus but translation occurs in the cytoplasm.

Reason (R) : m-RNA is transferred from the nucleus into the cytoplasm where ribosomes and amino acids are available for protein synthesis.

- A. If both A and R are true and R is the correct explanation of A

B. If both A and R are true but R is not the correct explanation of A

C. If A is true and R is false

D. If both A and R are false

Answer: A



[Watch Video Solution](#)

74. [A]: Cycads were prevalent during Jurassic period.

[R]: Jurassic period is considered as Age of cycads

A. If both A and R are true and R is the correct explanation of A

B. If both A and R are true but R is not the correct explanation of A

C. If A is true and R is false

D. If both A and R are false

Answer: A



[Watch Video Solution](#)

75. [A]: Evolution is descent with modification.

[R]: Evolution is derivation of new species of plants and animals from those existed in past.

- A. If both A and R are true and R is the correct explanation of A
- B. If both A and R are true but R is not the correct explanation of A
- C. If A is true and R is false
- D. If both A and R are false

Answer: D



[Watch Video Solution](#)

76. [A]: Isolation is a mechanism which prevents interbreeding among other wise potential mates.

[R]: It is the key factor without which all other factors of evolution will merge into jumble of no significance

- A. If both A and R are true and R is the correct explanation of A
- B. If both A and R are true but R is not the correct explanation of A
- C. If A is true and R is false
- D. If both A and R are false

Answer: B

 [Watch Video Solution](#)

77. [A]: Mesozoic era is known as the 'Age of Reptiles'.

[R]: It was the era of origin, differentiation and final extinction of dinosaurs which thrived in sea, in air and on land.

- A. If both A and R are true and R is the correct explanation of A
- B. If both A and R are true but R is not the correct explanation of A
- C. If A is true and R is false
- D. If both A and R are false

Answer: A



[Watch Video Solution](#)

78. [A]: Radioactive carbon ^{14}C method is quite accurate for relatively recent fossils, not older than 40,000 years.

[R]: It was discovered by Libby.

- A. If both A and R are true and R is the correct explanation of A
- B. If both A and R are true but R is not the correct explanation of A
- C. If A is true and R is false
- D. If both A and R are false

Answer: B



[Watch Video Solution](#)

79. [A]: According to Hardy-Weinberg law both gene frequencies and genotype frequencies will remain constant from generation to generation in an infinitely large interbreeding population.

[R]: Alleles segregating in a population tend to establish an equilibrium with reference to each other, thus maintain both frequencies constant.

- A. If both A and R are true and R is the correct explanation of A
- B. If both A and R are true but R is not the correct explanation of A
- C. If A is true and R is false
- D. If both A and R are false

Answer: A



[Watch Video Solution](#)

80. [A]: 'Ontogeny recapitulates phylogeny' was the concept put forward by Haeckel.

[R]: The embryonic stages show the course of evolution which an adult has gone through during development

- A. (a) If both A and R are true and R is the correct explanation of A
- B. (b) If both A and R are true but R is not the correct explanation of A
- C. (c) If A is true and R is false
- D. (d) If both A and R are false

Answer: A



Watch Video Solution

81. [A]: Vestigial organs are those parts of the body which are greatly reduced and are use- less.

[R]: These are the ruminants of once fully de- veloped organs which are gradually lost as these were no longer necessary

- A. If both A and R are true and R is the correct explanation of A
- B. If both A and R are true but R is not the correct explanation of A

C. If A is true and R is false

D. If both A and R are false

Answer: A



[Watch Video Solution](#)

82. [A]: Homology is the similarity between organs of same animal based on common ancestry.

[R]: Analogy is seen in every organ system from fish to man

A. (a) If both A and R are true and R is the correct explanation of A

B. (b) If both A and R are true but R is not the correct explanation of A

C. (c) If A is true and R is false

D. (d) If both A and R are false

Answer: D



[Watch Video Solution](#)

83. [A]: Ear muscles of external ear in man are well developed.

[R]: These muscles do not move external ear freely to detect sound

- A. If both A and R are true and R is the correct explanation of A
- B. If both A and R are true but R is not the correct explanation of A
- C. If A is true and R is false
- D. If both A and R are false

Answer: D



[Watch Video Solution](#)

84. [A]: Convergent evolution leads to production of analogous similarities among different groups of organisms.

[R]: Animals of the same group or closely related groups exhibit great divergences in their morphology

- A. If both A and R are true and R is the correct explanation of A

B. If both A and R are true but R is not the correct explanation of A

C. If A is true and R is false

D. If both A and R are false

Answer: B



Watch Video Solution

85. [A]: Heritable changes are also called mutations.

[R]: Mutations are sudden change in chromosomal DNA.

i) If both A and R are true and R is the correct explanation of A

ii) If both A and R are true but R is not the correct explanation of A

iii) If A is true and R is false

iv) If both A and R are false

A. If both A and R are true and R is the correct explanation of A

B. If both A and R are true but R is not the correct explanation of A

C. If A is true and R is false

D. If both A and R are false

Answer: A



[Watch Video Solution](#)

86. [A]: In some organisms the end stages of the ancestral development pattern are dropped, as in case of neoteny.

[R]: In some animals, some middle stages are dropped in the descendents.

a. If both A and R are true and R is the correct explanation of A

b. If both A and R are true but R is not the correct explanation of A

c. If A is true and R is false

d. If both A and R are false

A. If both A and R are true and R is the correct explanation of A

B. If both A and R are true but R is not the correct explanation of A

C. If A is true and R is false

D. If both A and R are false

Answer: B



Watch Video Solution

87. [A]: Homologous organs have similar structure but different functions.

[R]: It is believed that homologous structures were created for different purposes and their present function is secondarily achieved out of necessity

A. If both A and R are true and R is the correct explanation of A

B. If both A and R are true but R is not the correct explanation of A

C. If A is true and R is false

D. If both A and R are false

Answer: A



[Watch Video Solution](#)

88. [A]: In large groups of animals and plants, there are identical enzymes and hormones available.

[R]: This suggests organic evolution

- A. If both A and R are true and R is the correct explanation of A
- B. If both A and R are true but R is not the correct explanation of A
- C. If A is true and R is false
- D. If both A and R are false

Answer: A



[Watch Video Solution](#)

89. [A]: During evolution of Primates, various groups diverged in a particular sequence from the main line of descent.

[R]: Prosimians (Tarsiers, lemurs) which diverged first, are most distantly related to humans and most closely related to original primates.

- A. If both A and R are true and R is the correct explanation of A
- B. If both A and R are true but R is not the correct explanation of A
- C. If A is true and R is false
- D. If both A and R are false

Answer: B



Watch Video Solution

90. [A]: Macro evolution produces groups of parallel special adaptations among convergent but related species.

[R]: Adaptive radiation/macroevolution don't produce evolutionary lines that converge in special adaptation with other related groups differing in general adaptation

- A. If both A and R are true and R is the correct explanation of A

B. If both A and R are true but R is not the correct explanation of A

C. If A is true and R is false

D. If both A and R are false

Answer: D



Watch Video Solution

91. [A] : Organisms that bear large number of common amino acid sequence may be considered to be more closely related than to those with greatly different amino acid sequence.

[R]: The proteins are chemical finger prints of evolutionary history because they bear amino acid sequences that have changed as a result of genetic change

A. If both A and R are true and R is the correct explanation of A

B. If both A and R are true but R is not the correct explanation of A

C. If A is true and R is false

D. If both A and R are false

Answer: A

 [Watch Video Solution](#)

92. [A]: Homologous organs are similar in basic structure and embryonic origin, but serve different functions.

[R]: Similarity in basic structure points to common ancestry whereas diversity in function reflects adaptation to different modes of life.

A. If both A and R are true and R is the correct explanation of A

B. If both A and R are true but R is not the correct explanation of A

C. If A is true and R is false

D. If both A and R are false

Answer: A

 [Watch Video Solution](#)

93. Assertion: Analogous organs serve the same function and look alike, but have different structure and embryonic origin.

Reason: Analogous organs have no specific significance

- A. If both A and R are true and R is the correct explanation of A
- B. If both A and R are true but R is not the correct explanation of A
- C. If A is true and R is false
- D. If both A and R are false

Answer: C



Watch Video Solution

94. Assertion: Frog's tadpole has fish-like form, tail and gills

Reason: Tadpole stage is the recapitulation of the fish-like ancestor of frog in the latter's life history

- A. If both A and R are true and R is the correct explanation of A

B. If both A and R are true but R is not the correct explanation of A

C. If A is true and R is false

D. If both A and R are false

Answer: A



Watch Video Solution

95. Assertion:Jurassic period is considered as the age of reptiles.

Reason:Reptiles dominated in all habitats during Jurassic period

A. If both A and R are true and R is the correct explanation of A

B. If both A and R are true but R is not the correct explanation of A

C. If A is true and R is false

D. If both A and R are false

Answer: A



Watch Video Solution

96. [A]: Some babies have a small tail.

[R]: This is just a freak of nature and has no explanation

- A. If both A and R are true and R is the correct explanation of A
- B. If both A and R are true but R is not the correct explanation of A
- C. If A is true and R is false
- D. If both A and R are false

Answer: C



[Watch Video Solution](#)

97. [A]: The first life originated was chemoheterotrophic.

[R]: The first life originated in sea water.

- A. If both A and R are true and R is the correct explanation of A
- B. If both A and R are true but R is not the correct explanation of A

C. If A is true and R is false

D. If both A and R are false

Answer: B



[Watch Video Solution](#)

98. [A]: Evolution is a theory.

[R]: As it is based on causes and evidences.

A. If both A and R are true and R is the correct explanation of A

B. If both A and R are true but R is not the correct explanation of A

C. If A is true and R is false

D. If both A and R are false

Answer: A



[Watch Video Solution](#)

99. [A]: Cabbage, cauliflower, Kohlrabi, Broccoli and Brussels have descended from a common ancestor Colewort (Brassica oleracea).

[R]: These varieties were produced through selective breeding (artificial selection) of domesticated wild species

- A. If both A and R are true and R is the correct explanation of A
- B. If both A and R are true but R is not the correct explanation of A
- C. If A is true and R is false
- D. If both A and R are false

Answer: A



[Watch Video Solution](#)

100. [A]: Evolution is not occurring at present.

[R]: Evolution is a very lengthy process

- A. If both A and R are true and R is the correct explanation of A

B. If both A and R are true but R is not the correct explanation of A

C. If A is true and R is false

D. If both A and R are false

Answer: D



Watch Video Solution

101. [A]: According to the theory of Lamarck use and disuse caused the increase and decrease in size of organs and environment caused the changes which can be transferred to next generation.

[R]: Modern synthetic theory is also known as Neo-Lamarckism.

A. (a) If both A and R are true and R is the correct explanation of A

B. (b) If both A and R are true but R is not the correct explanation of A

C. (c) If A is true and R is false

D. (d) If both A and R are false

Answer: C



[Watch Video Solution](#)

102. [A]: Fossils of Peking man were discovered from caves near Peking in 1920 by Davidson Black.

[R]: It was quite intelligent to use and construct flint tools and is supposed to perform ceremonies

- A. (a) If both A and R are true and R is the correct explanation of A
- B. (b) If both A and R are true but R is not the correct explanation of A
- C. (c) If A is true and R is false
- D. (d) If both A and R are false

Answer: C



[Watch Video Solution](#)

103. [A]: Man's most characteristic feature in which it differs from all its primate relatives is his large brain and high intelligence.

[R]: A lumbar curve is absent in man which is present in apes

- A. If both A and R are true and R is the correct explanation of A
- B. If both A and R are true but R is not the correct explanation of A
- C. If A is true and R is false
- D. If both A and R are false

Answer: C



[Watch Video Solution](#)

104. [A]: Darwin held that small favourable variations formed the raw material for evolution.

[R]: Darwin did not go into the factors which produce variations

- A. If both A and R are true and R is the correct explanation of A

B. If both A and R are true but R is not the correct explanation of A

C. If A is true and R is false

D. If both A and R are false

Answer: B



Watch Video Solution

105. Assertion : A single mutation may produce a new species .

Reason : Mutation may cause major variation in genetic material and these are inheritable .

A. If both A and R are true and R is the correct explanation of A

B. If both A and R are true but R is not the correct explanation of A

C. If A is true and R is false

D. If both A and R are false

Answer: A



[Watch Video Solution](#)

106. [A]: Isolation prevents inbreeding among the otherwise potential mates.

[R]: It preserves variations which can lead to speciation.

- A. (a) If both A and R are true and R is the correct explanation of A
- B. (b) If both A and R are true but R is not the correct explanation of A
- C. (c) If A is true and R is false
- D. (d) If both A and R are false

Answer: A



[Watch Video Solution](#)

107. [A]: Interspecific mating often produces a more vigorous but sterile F_1 hybrids.

[R]: Reproductive isolation does not let evolution to occur.

- A. If both A and R are true and R is the correct explanation of A
- B. If both A and R are true but R is not the correct explanation of A
- C. If A is true and R is false
- D. If both A and R are false

Answer: C

 [Watch Video Solution](#)

108. [A]: Basis of adaptation is the preexisting gene mutation.

[R]: In changed environment, a hidden gene mutation may express and result in survival of the organisms and finally lead to adaptation to new conditions.

- A. If both A and R are true and R is the correct explanation of A
- B. If both A and R are true but R is not the correct explanation of A
- C. If A is true and R is false
- D. If both A and R are false

Answer: A



[Watch Video Solution](#)

109. [A]: Artificial selection is done only in animal breeding.

[R]: Artificial selection is done in animal breeding only.

- A. If both A and R are true and R is the correct explanation of A
- B. If both A and R are true but R is not the correct explanation of A
- C. If A is true and R is false
- D. If both A and R are false

Answer: D



[Watch Video Solution](#)

110. [A]: Presence of tail in children is a vestigial character.

[R]: This is due to the phenomenon called atavism

- A. If both A and R are true and R is the correct explanation of A
- B. If both A and R are true but R is not the correct explanation of A
- C. If A is true and R is false
- D. If both A and R are false

Answer: A

 [Watch Video Solution](#)

111. [A]: Mimics are always or more often defenceless.

[R]: Mimics are always less in number than the model individuals

- A. If both A and R are true and R is the correct explanation of A
- B. If both A and R are true but R is not the correct explanation of A
- C. If A is true and R is false
- D. If both A and R are false

Answer: B

 [Watch Video Solution](#)

112. [A]: The process of speciation occurs only in allopatric populations.

[R]: The sympatric species can arise either due to changes in the chromosome number or due to introgressive hybridization and polyploidy.

- A. If both A and R are true and R is the correct explanation of A
- B. If both A and R are true but R is not the correct explanation of A
- C. If A is true and R is false
- D. If both A and R are false

Answer: B

 [Watch Video Solution](#)

113. [A]: The establishment of reproductive isolation is an event of biological significance.

[R]: Because in absence of reproductive isolation they can merge back into single population

- A. If both A and R are true and R is the correct explanation of A
- B. If both A and R are true but R is not the correct explanation of A
- C. If A is true and R is false
- D. If both A and R are false

Answer: A



Watch Video Solution

114. [A]: Varied groups of plants and animals either related or unrelated provide an example of divergent evolution.

[R]: The changes occur in a cumulative direction and result in the origin of new populations from the old ones

- A. If both A and R are true and R is the correct explanation of A
- B. If both A and R are true but R is not the correct explanation of A

C. If A is true and R is false

D. If both A and R are false

Answer: A



[Watch Video Solution](#)

115. [A]: The natural hybrids of the species are either totally absent or are very rare.

[R]: Because members of separate species do not interbreed usually

A. If both A and R are true and R is the correct explanation of A

B. If both A and R are true but R is not the correct explanation of A

C. If A is true and R is false

D. If both A and R are false

Answer: A



[Watch Video Solution](#)

116. [A]: The earliest living organisms were structurally simple.

[R]: The earliest living organisms were more complex than present one.

A. If both A and R are true and R is the correct explanation of A

B. If both A and R are true but R is not the correct explanation of A

C. If A is true and R is false

D. If both A and R are false

Answer: C



Watch Video Solution

117. [A]: There is no phenomenon like organic evolution.

[R]: Evolution, is a discontinuous period

A. If both A and R are true and R is the correct explanation of A

B. If both A and R are true but R is not the correct explanation of A

C. If A is true and R is false

D. If both A and R are false

Answer: D



[Watch Video Solution](#)

118. Assertion : Human ancestors never used their tails and so the tails expressing gene has disappeared in them.

Reason : Lamarck's theory of evolution is popularly called theory of continuity of germ plasm.

A. (a) If both A and R are true and R is the correct explanation of A

B. (b) If both A and R are true but R is not the correct explanation of A

C. (c) If A is true and R is false

D. (d) If both A and R are false

Answer: D



119. Assertion : Comparative biochemistry provides a strong evidence in favour of common ancestry of living beings.

Reason : Genetic code is universal.

- A. (a) If both A and R are true and R is the correct explanation of A
- B. (b) If both A and R are true but R is not the correct explanation of A
- C. (c) If A is true and R is false
- D. (d) If both A and R are false

Answer: A



120. Assertion : Darwin's finches show a variety of beaks suited for eating large seeds, flying insects and cactus seeds.

Reason : Ancestral seed-eating stock of Darwin's finches radiated out from

South American mainland to different geographical areas of the Galapagos Island, where they found competitor-free new habitats.

- A. If both A and R are true and R is the correct explanation of A
- B. If both A and R are true but R is not the correct explanation of A
- C. If A is true and R is false
- D. If both A and R are false

Answer: A



Watch Video Solution

121. Assertion: Human and great apes have a common ancestry.

Reason: Man and chimpanzee have similar banding pattern of chromosomes number 3 and 6

- A. If both A and R are true and R is the correct explanation of A
- B. If both A and R are true but R is not the correct explanation of A
- C. If A is true and R is false

D. If both A and R are false

Answer: A



[Watch Video Solution](#)

122. Assertion: Man has descended from monkeys.

Reason: Monkeys resemble humans more than apes do

- A. (a) If both A and R are true and R is the correct explanation of A
- B. (b) If both A and R are true but R is not the correct explanation of A
- C. (c) If A is true and R is false
- D. (d) If both A and R are false

Answer: D



[Watch Video Solution](#)