



PHYSICS

BOOKS - SUNSTAR PHYSICS

(KANNADA ENGLISH)

K-CET-PHYSICS-2019

Multiple Choice Questions

1. Two particles which are initially at rest move towards each other under the action of their

mutual attraction. If their speeds are v and $2v$ at any instant, then the speed of center of mass of the system is,

A. $1.5V$

B. $2V$

C. V

D. Zero

Answer: D



Watch Video Solution

2. A particle is moving uniformly along a straight line as shown in the figure. During the motion of the particle from A to B, the angular momentum of the particle about .O.



- A. remains constant
- B. increase
- C. first increase then decreases
- D. decrease

Answer: A



3. A satellite is orbiting close to the earth and has a kinetic energy K . The minimum extra kinetic energy required by it to just overcome the gravitation pull of the earth is

A. $\sqrt{3}K$

B. k

C. $2\sqrt{2}k$

D. $2K$

Answer: B



Watch Video Solution

4. A wire is stretched such that its volume remains constant. The Poisson's ratio of the material of the wire is

A. 0.25

B. 0.50

C. -0.25

D. -0.50

Answer: D



Watch Video Solution

5. A cylindrical container containing water has a small hole at height of $H = 8$ cm from the bottom and at a depth of 2cm from the top surface of the liquid. The maximum horizontal distance travelled by the water before it hits the ground (x) is $\lambda/3$ is.



A. 4 cm

B. 8 cm

C. 6 cm

D. $4\sqrt{2}$ cm

Answer: B



View Text Solution

6. A transparent medium shows relation between i and r as shown. If the speed of light in vacuum is c , the Brewster's angle for the

medium

is

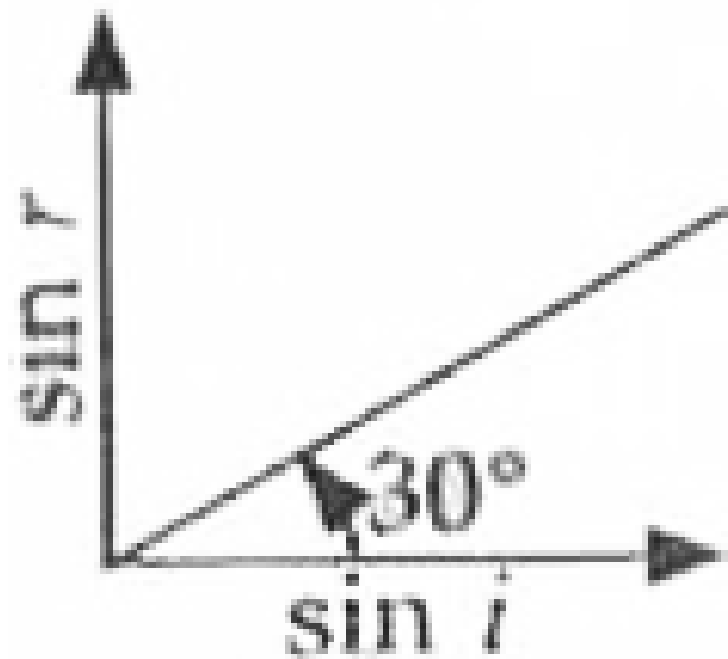

A. 60°

B. 30°

C. 90°

D. 45°

Answer: A



Watch Video Solution

7. In Young's double slit experiment, using monochromatic light of wavelength λ , the intensity of light at a point on the screen where path difference is λ is K units. The intensity of light at a point where path difference is $\lambda/3$ is.

A. $4K$

B. K

C. $2K$

D. $K/4$

Answer: D



Watch Video Solution

8. Due to Doppler's effect, the shift in wavelength observed is 0.1 \AA for a star

producing wavelength 6000 \AA . Velocity of recession of the star will be

- A. 5 km/s
- B. 25 km/s .
- C. 20 km/s
- D. 10 km/s

Answer: A



Watch Video Solution

9. An electron is moving with an initial velocity

$\vec{v} = v_0 \hat{i}$ and is in a uniform magnetic field

$\vec{B} = B_0 \hat{j}$.

Then its de Broglie wavelength

- A. decrease with time
- B. remains constant
- C. increase and decrease periodically
- D. increases with time

Answer: B



Watch Video Solution

10. Light of certain frequency and intensity incident on a photosensitive material causes photoelectric effect. If both the frequency and intensity are doubled, the photoelectric saturation current becomes

- A. halved
- B. quadruple
- C. unchanged
- D. doubled

Answer: D



Watch Video Solution

11. In a cyclotron a charged particle

A. speeds up in dee

B. undergoes acceleration all the time

C. slows down within a dee and speeds up

between dees

D. speeds up between the dees because of
the magnetic field

Answer: B



Watch Video Solution

12. The number of turns in a coil of
Galvanometer is tripled, then

A. Both voltage and current sensitivity
remains constant

B. Voltage sensitivity increases 3 times and current sensitivity remains constant

C. Both voltage and current sensitivity decreases by 33%

D. Voltage sensitivity remains constant and current sensitivity increases 3 times

Answer: D



Watch Video Solution

13. A circular current loop of magnetic moment M is in an arbitrary orientation in an external uniform magnetic field \vec{B} . The work done to rotate the loop by 30° about an axis perpendicular to its plane is

A. $\frac{MB}{2}$

B. MB

C. Zero

D. $\sqrt{3}\frac{MB}{2}$

Answer: C



Watch Video Solution

14. In a permanent magnet at room temperature

A. domains are partially aligned

B. magnetic moment of each molecule is zero

C. domains are all perfectly aligned

D. the individual molecules have non zero magnetic moment which are all perfectly

aligned

Answer: C



Watch Video Solution

15. Coercivity of a magnet where the ferromagnet gets completely demagnetized is $3 \times 10^3 \text{ A m}^{-1}$, The minimum current required to be passed in a solenoid having 1000 turns per metre, so that the magnet gets

completely demagnetized when placed inside
the solenoid is

A. 3A

B. 30mA

C. 6A

D. 60mA

Answer: A



Watch Video Solution

16. Which one of the following nuclei has shorter mean life?



A. C

B. A

C. same for all

D. B

Answer: B



View Text Solution

17. The conductivity of semiconductor increases with increase in temperature because

A. both number density of charge carriers and relaxation time increase

B. number density of charge carriers increases

C. number density of current carriers increases, relaxation time decreases but effect of decrease in relaxation time is

much less than increase in number
density

D. relaxation time increases

Answer: C



Watch Video Solution

18. For a transistor amplifier, the voltage gain

A. is low at high and low frequencies and
constant at mid frequencies

B. remains constant for all frequencies

C. constant at high frequencies and low at
low frequencies

D. is high at high and low frequencies and
constant in the middle frequency range

Answer: A



Watch Video Solution

19. An antenna uses electromagnetic waves of frequency 5 MHz. For proper working, the size of the antenna should be

A. 15 km

B. 15 m

C. 3km

D. 300 m

Answer: A



Watch Video Solution

20. A magnetic needle has a magnetic moment of $5 \times 10^{-2} \text{ Am}^2$ and moment of inertia $8 \times 10^{-6} \text{ kg m}^2$. It has a period of oscillation of 2 s in a magnetic field \vec{B} . The magnitude of magnetic field is approximately

A. $3.2 \times 10^{-4} \text{ T}$

B. $1.6 \times 10^{-4} \text{ T}$

C. $0.8 \times 10^{-4} \text{ T}$

D. $0.4 \times 10^{-4} \text{ T}$

Answer:



Watch Video Solution

21. A toroid has 500 turns per metre length. If it carries a current of 2 A, the magnetic energy density inside the toroid is

A. $6.28J / m^3$

B. $0.628J / m^3$

C. $3.14J / m^3$

D. $0.314J / m^3$

Answer: B



Watch Video Solution

22. Consider the situation given in figure. The wire AB is slide on the fixed rails with a constant velocity. If the wire AB is replaced by a semicircular wire, the magnitude of the induced current will

A. decrease

B. increase

C. increase or decrease depending on whether the semicircle bulges towards the resistance or away from it

D. remain same

Answer: D



Watch Video Solution

23. The frequency of an alternating current is 50 Hz. What is the minimum time taken by

current to reach its peak value from rms value

?

A. $0.02s$

B. $5 \times 10^{-3}S$

C. $10 \times 10^{-3}S$

D. $2.5 \times 10^{-3}S$

Answer: D



Watch Video Solution

24. The readings of ammeter and voltmeter in the following circuit are respectively



A. $2.7A$, $220V$

B. $1.2A$, $120V$

C. $2.2A$, $220V$

D. $1.5A$, $100V$

Answer: C



View Text Solution

25. A certain charge $2Q$ is divided at first into two parts q_1 and q_2 . Later the charges are placed at a certain distance. If the force of interaction between two charges is maximum

then $\frac{Q}{q_1} = \text{-----}$.

A. 1

B. 4

C. 0.5

D. 2

Answer: A



Watch Video Solution

26. A particle of mass m and charge q is placed at rest in uniform electric field E and then released. The kinetic energy attained by the particle after moving a distance y is

A. qEy

B. $qEye^2$

C. q^2Ey

D. qE^2y

Answer: A



Watch Video Solution

27. An electric dipole is kept in non-uniform electric field. It generally experiences

- A. A torque but not a force
- B. A force and torque
- C. Neither a force nor a torque
- D. A force but not a torque

Answer: B



Watch Video Solution

28. The figure gives the electric potential V as a function of distance through four regions , on x -axis. Which of the following is true for the

magnitude of the electric field E in these

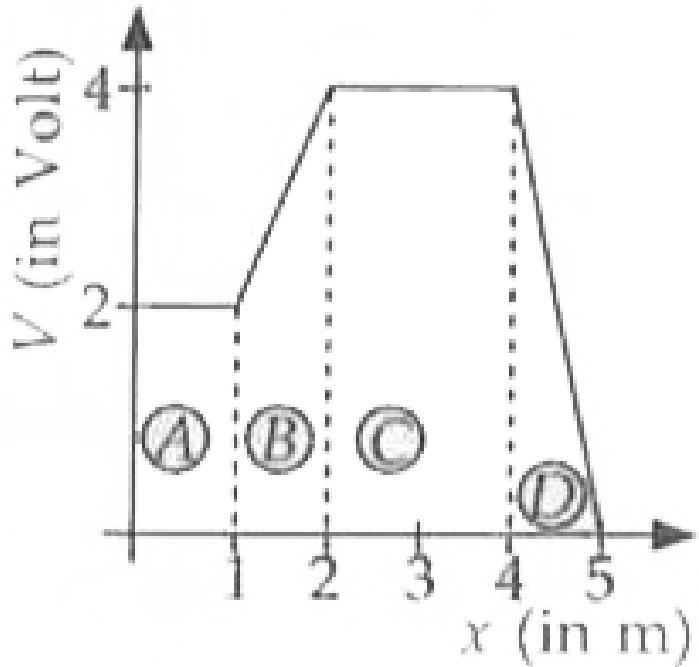

regions?

A. $E_n = E_D$ and $E_A < E_C$

B. $E_A > E_C > E_D$

C. $E_A < E_a < E_C < E_D$

D. $E_A = E_C$ and $E_n < E_D$

Answer: D



Watch Video Solution

29. A system of two charges separated by a certain distance apart stores electrical potential energy. If the distance between them is increased, the potential energy of the system,

A. may increase or decrease

B. increases in any case

C. remains the same

D. decreases in any case

Answer: A



Watch Video Solution

30. If P , Q and R are physical quantities having different dimensions, which of the following combinations can never be a meaningful quantity?

A. $\frac{PQ}{R}$

B. $\frac{P - Q}{R}$

C. $\frac{PR - Q^2}{R}$

D. $PQ - R$

Answer: C



Watch Video Solution

31. The given graph shows the variation of velocity (v) with position (x) for a particle moving along a straight line. Which of the

following graph shows the variation of acceleration (a) with position (x)?

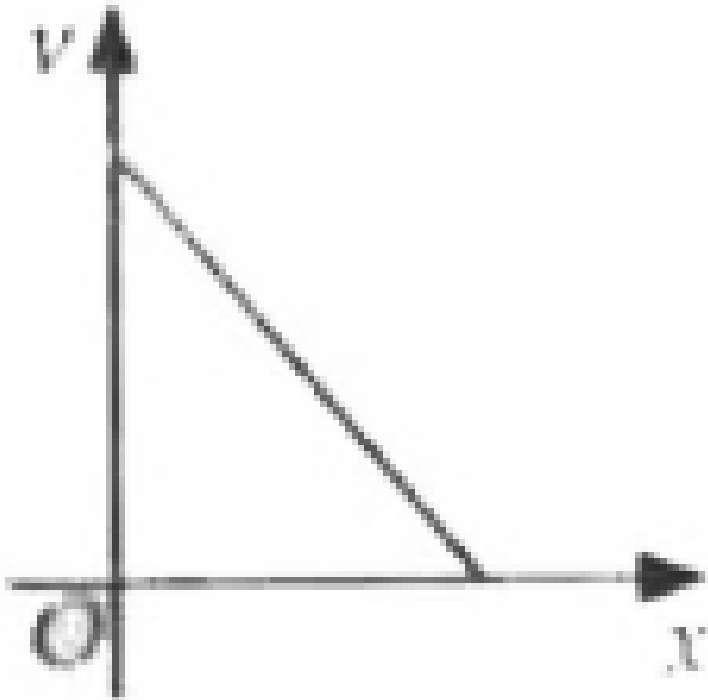

A. 

B. 

C. 

D. 

Answer: A



Watch Video Solution

32. The trajectory of a projectile projected from origin is given by the equation $y = x - \frac{2x^2}{5}$. The initial velocity of the projectile is

A. $25ms^{-1}$

B. $2/5ms^{-1}$

C. $5/2ms^{-1}$

D. $5ms^{-1}$

Answer: D



Watch Video Solution

33. An object with mass 5 kg is acted upon by a force, $\vec{F} = (-3\hat{i} + 4\hat{j})$ N. If its initial velocity at $t = 0$ is $\vec{v} = (6\hat{i} - 12\hat{j})$ m s⁻¹, the

time at which it will just have a velocity along y-axis is

A. 2s

B. 5s

C. 15s

D. 10s

Answer: D



Watch Video Solution

34. During inelastic collision between two objects, which of the following quantity always remains conserved?

- A. Total linear momentum
- B. Total kinetic energy
- C. Speed of each body
- D. Total mechanical energy

Answer: A



Watch Video Solution

35. In Rutherford experiment, for head-on collision of α particles with a gold nucleus, the impact parameter is

A. of the order 10^{-10} m

B. zero

C. of the order of 10^{-6} m

D. of the order of 10^{-14} m

Answer: D



Watch Video Solution

36. Frequency of revolution of an electron revolving in n^{th} orbit of H-atom is proportional to

A. n independent of n

B. $1/n^2$

C. $1/n^2$

D. n

Answer: C



Watch Video Solution

37. A hydrogen atom in ground state absorbs 10.2 eV of energy. The orbital angular momentum of the electron is increased by

A. $3.16 \times 10^{-34} \text{ Js}$

B. $1.05 \times 10^{-14} \text{ Js}$

C. $4.22 \times 10^{-34} \text{ Js}$

D. $2.11 \times 10^{-34} \text{ Js}$

Answer: B



Watch Video Solution

38. The end product of decay of ${}_{90}\text{Th}^{232}$ is ${}_{82}\text{Pb}^{208}$. The number of α and β particles emitted are respectively

A. 6,0

B. 3,3

C. 4,6

D. 6,4

Answer: D



Watch Video Solution

39. Two protons are kept at a separation of 10 nm. Let F_n and F_e be the nuclear force and the electromagnetic force between them .

A. $F_e < F_n$

B. $F_e = F_n$

C. F_e and F_n differ only slightly

D. $F_e > F_n$

Answer: D



Watch Video Solution

40. Two metal plates are separated by 2 cm. The potentials of the plates are -10 V and $+30$ V. The electric field between the two plates is

A. 2000 V/m

B. 500 V/m

C. 3000 V/m

D. 1000 V/m

Answer: A



Watch Video Solution

41. The equivalent capacitance between A and B is

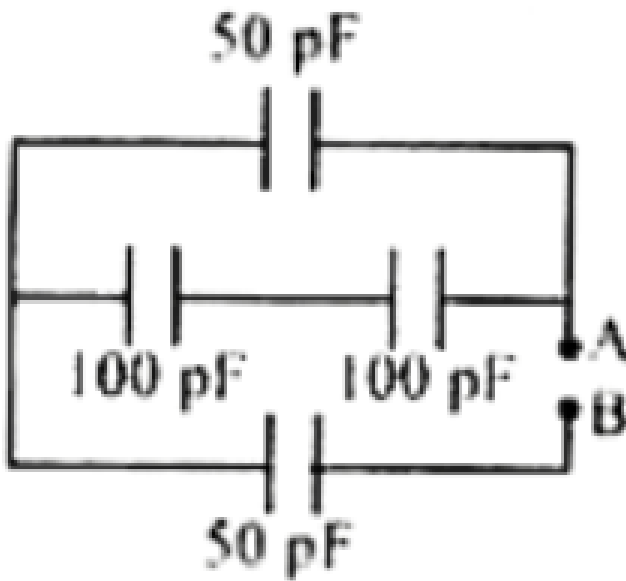

A. 150 pF

B. 50 pF

C. 300 pF

D. $100/3 \text{ pF}$

Answer: D



Watch Video Solution

42. A capacitor of capacitance C charged by an amount Q is connected in parallel with an uncharged capacitor of capacitance $2C$. The final charges on the capacitors are

A. $\frac{Q}{3}, \frac{2Q}{3}$

B. $\frac{Q}{2}, \frac{Q}{2}$

C. $\frac{Q}{5}, \frac{4Q}{5}$

D. $\frac{Q}{4}, \frac{3Q}{4}$

Answer: A



Watch Video Solution

43. Though the electron drift velocity is small and electron charge is very small, a conductor can carry an appreciably large current because

A. electron number density depends on temperature

B. electron number density is very large

C. relaxation time is small

D. drift velocity of electron is very large

Answer: B



Watch Video Solution

44. Masses of three wires of copper are in the ratio $1 : 3 : 5$ and their lengths are in the ratio $5 : 3 : 1$. The ratio of their electrical resistance are

A. $1 : 15 : 125$

B. $1 : 3 : 5$

C. $125 : 15 : 1$

D. $5 : 3 : 1$

Answer: C



Watch Video Solution

45. An aluminium sphere is dipped into water.

Which of the following is true?

A. Buoyancy in water at 0°C will be same as

that in water at 4°C

B. Buoyancy will be less in water at 0°C

than that in water at 4°C

C. Buoyancy may be more or less in water

at 4°C depending on the radius of the

sphere

D. Buoyancy will be more in water at 0°C than that in water at 4°C

Answer: B



Watch Video Solution

46. A thermodynamic system undergoes a cyclic process ABC as shown in the diagram.

The work done by the system, per cycle is

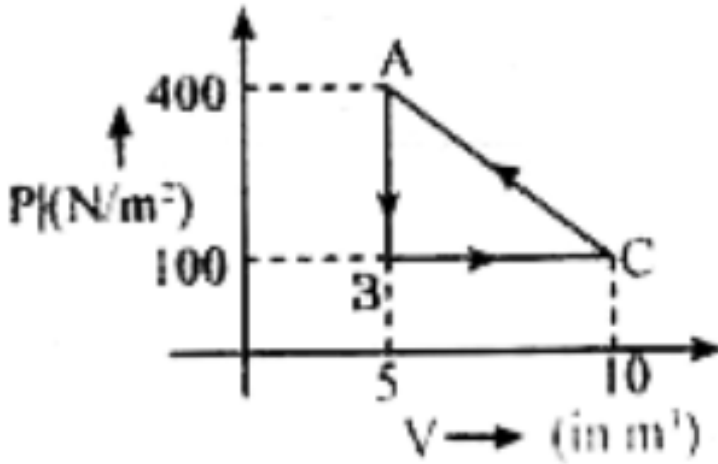

A. $-750J$

B. $750J$

C. $1250J$

D. $-1250J$

Answer: A



Watch Video Solution

47. One mole of O_2 gas is heated at constant pressure starting at 27°C . How much energy must be added to the gas as heat to double its volume?

A. $750R$

B. Zero

C. $1050R$

D. $450R$

Answer: C



Watch Video Solution

48. A piston is performing S.H.M. in the vertical direction with a frequency of 0.5 Hz. A block of 10 kg is placed on the piston. The maximum amplitude of the system such that the block remains in contact with the piston is.

A. 1.5m

B. 1m

C. 0.1m

D. 0.5m

Answer: B



Watch Video Solution

49. The equation of a stationary wave is $y = 2 \sin \left(\frac{\pi x}{15} \right) \cos(48\pi t)$. The distance between a node and its next antinode is.

A. 22.5 units

B. 7.5 units

C. 30 units

D. 1.5 units

Answer: B



Watch Video Solution

50. An inductor of inductance L and resistor R are joined together in series and connected by a source of frequency ω . The power dissipated in the circuit is

- A. $\frac{V}{R^2 + \omega^2 L^2}$
- B. $\frac{R^2 + \omega^2 L^2}{V}$
- C. $\frac{V^2 R}{\sqrt{R^2 + \omega^2 L^2}}$
- D. $\frac{V^2 R}{R^2 + \omega^2 L^2}$

Answer: C



Watch Video Solution

51. An electromagnetic wave is travelling in x-direction with electric field vector given by,

$\vec{E}_y = E_A \sin(kx - \omega t) \hat{j}$. The correct expression for magnetic field vector is .

A. $\vec{B} = \frac{E_a}{C} \sin(kx - \omega t) \hat{j}$

B. $\vec{E} = E_0 C \sin(kx - \omega t) \hat{j}$

C. $\vec{B}_x = \frac{E_n}{C} \sin(kx - \omega t) \hat{k}$

D. $\vec{E}_a = E_0 \sin(kx - \omega t) \hat{k}$

Answer: C



Watch Video Solution

52. The phenomenon involved in the reflection of radio-waves by ionosphere is similar to

A. dispersion of light by water molecules

during the formation

B. reflection of light by plane mirror

C. scattering of light by air particles

D. total internal reflection of light in air

during a mirage

Answer: D

53. A point object is moving uniformly towards the pole of a concave mirror of focal length 25cm along its axis as shown below. The speed of the object is 1 ms. At $t = 0$, the distance of the object from the mirror is 50cm. the average velocity of the image formed by the mirror between time $t = 0$ and $t = 0.25$ s is:

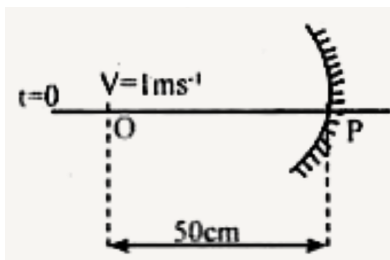

A. zero

B. 40cm s^{-1}

C. Infinity

D. 20cm s^{-1}

Answer: C



Watch Video Solution

54. A certain prism is found to produce a minimum deviation of 38° . It produces a deviation of 44° when the angle of incidence

is either 42° or 62° . What is the angle of incidence when it is undergoing minimum deviation?

A. 49°

B. 30°

C. 60°

D. 40°

Answer: A



Watch Video Solution

55. In the given circuit, the current through 2Ω resistor is

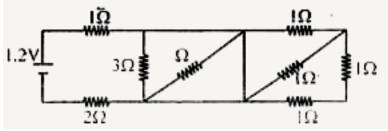

A. $0.4A$

B. $0.2A$

C. $0.1A$

D. $0.3A$

Answer: D



View Text Solution

56. Kirchhoff's junction rule is a reflection of

- A. Conservation of momentum
- B. Conservation of current density vector
- C. Conservation of charges
- D. Conservation of energy

Answer: D



Watch Video Solution

57. The variation of terminal potential difference (V) with current flowing through a cell is as shown

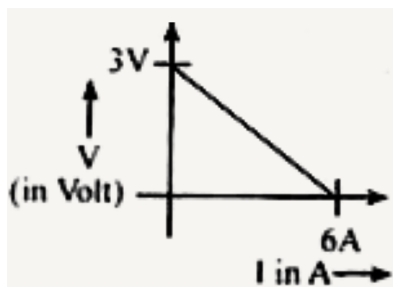

The emf and internal resistance of the cell are

- A. $6V, 2\Omega$
- B. $3V, 2\Omega$
- C. $6V, 0.5\Omega$
- D. $3V, 0.5\Omega$

Answer: D



Watch Video Solution

58. In a potentiometer experiment, the balancing point with a cell is at a length 240 cm. on shunting the cell with a resistance of 2Ω the balancing length becomes 120 cm. The internal resistance of the cell is

A. 1Ω

B. 4Ω

C. 0.5Ω

D. 2Ω

Answer: D



Watch Video Solution

59. The magnetic fields at the centre .O' in the given figure is

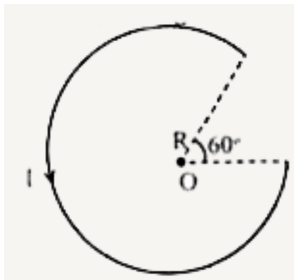

A. $\frac{3}{10} \frac{\mu_0 I}{R}$

B. $\frac{7}{14} \frac{\mu_0 l}{R}$

C. $\frac{\mu_0 l}{12R}$

D. $\frac{5}{12} \frac{\mu_0 l}{R}$

Answer: D



View Text Solution