



PHYSICS

BOOKS - AIIMS PREVIOUS YEAR PAPERS

AIIMS 2015

Physics

1. A particle is projected with an angle of projection θ to the horizontal line passing

through the points (P,Q) and (Q,P) referred to horizontal and vertical axes (can be treated as X-axis and Y-axis respectively). The angle of projection can be given by

A. $\tan^2 \left[\frac{P^2 + PQ + Q^2}{PQ} \right]$

B. $\tan^{-1} \left[\frac{P^2 + Q^2 - PQ}{PQ} \right]$

C. $\tan^{-1} \left[\frac{P^2 + Q^2}{2PQ} \right]$

D. $\sin^{-1} \left[\frac{P^2 + Q^2 + PQ}{2PQ} \right]$

Answer: A



Watch Video Solution

2. Determine the height above the dashed line XX' attained by the water stream coming out through the hole is situated at point B in the diagram given below. Given that $h = 10m$, $L = 2m$ and $\alpha = 30^\circ$.

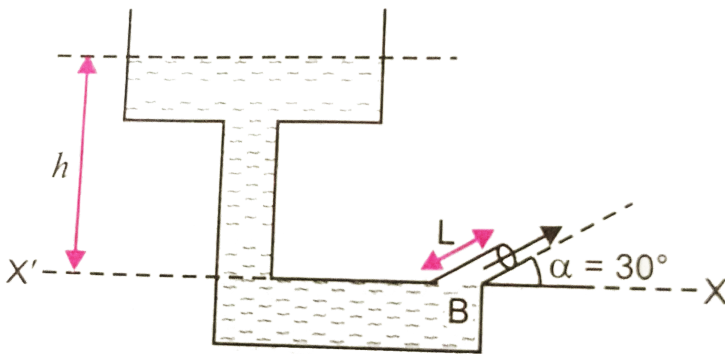

A. 10 m

B. 7.1 m

C. 5 m

D. 3.2 m

Answer: D



Watch Video Solution

3. If the magnetising field on a ferromagnetic material is increased, its permeability is

A. decreased

B. increased

C. is unaffected

D. may be increased or decreased

Answer: A



Watch Video Solution

4. The ball is dropped from a bridge $122.5m$ above a river, After the ball has been falling for 2 s , a second ball is thrown straight down after it. What must its initial velocity be so that both hit the water at the same time ?

A. 40 m/s

B. 55.5 m/s

C. 26.1 m/s

D. 9.6 m/s

Answer: C



Watch Video Solution

5. A body of mass 40kg resting on a rough horizontal surface is subjected to a force P which is just enough to start the motion of

the body. If $\mu_s = 0.5\mu_k = 0.4$, $g = 10\text{ms}^{-2}$
and the force P is continuously applied on the
body, then the acceleration of the body is.

A. zero

B. $1\text{m} / \text{s}^2$

C. $2\text{m} / \text{s}^2$

D. $2.4\text{m} / \text{s}^2$

Answer: B



Watch Video Solution

6. The self-inductance of a coil having 500 turns is 50 mH. The magnetic flux through the cross-sectional area of the coil while current through it is 8 mA is found to be

A. $4 \times 10^{-4} \text{Wb}$

B. 0.04Wb

C. $4 \mu \text{Wb}$

D. 40mWb

Answer: A



Watch Video Solution

7. A uniform metallic rod rotates about its perpendicular bisector with constant angular speed. If it is heated uniformly to raise its temperature slightly, then

A. its speed of rotation increases

B. its speed of rotation decreases

C. its speed of rotation remains same

D. its speed increases because its moment of inertia increase

Answer: B



Watch Video Solution

8. A uniform disc is acted by two equal forces of magnitude F . One of them, acts tangentially to the disc, while other one is acting at the central point of the disc. The friction between disc surface and ground surface is nF . If r be the radius of the disc, then the value of n would be (in N)

A. 0

B. 1.2

C. 2.0

D. 3.2

Answer: A



Watch Video Solution

9. In a given solenoid if the number of turns and the length of the solenoid are doubled

keeping the area of cross-section same, then
it's inductance:

A. halved

B. doubled

C. $1/4$ times the original value

D. unaffected

Answer: B



Watch Video Solution

10. Consider the circular loop having current I and with central point O . The magnetic field at the central point O is

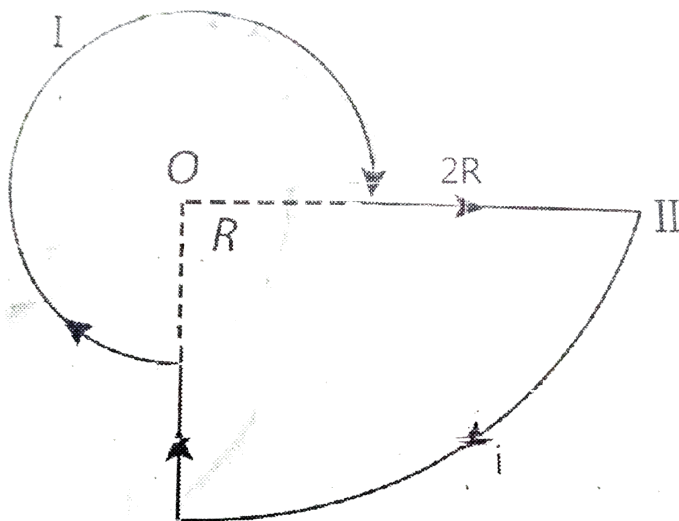

- A. $\frac{2\mu_0 i}{3\pi R}$ acting downward
- B. $\frac{5\mu_0 i}{12R}$ acting downward
- C. $\frac{6\mu_0 i}{11R}$ acting downward

D. $\frac{3\mu_0 i}{7R}$ acting upward

Answer: B



View Text Solution

11. The Boolean expression $P + \bar{P}Q$, where P and Q are the inputs of the logic circuit, represents

A. AND gate

B. NAND gate

C. NOT gate

D. OR gate

Answer: D



Watch Video Solution

12. Consider the diagram shown below.

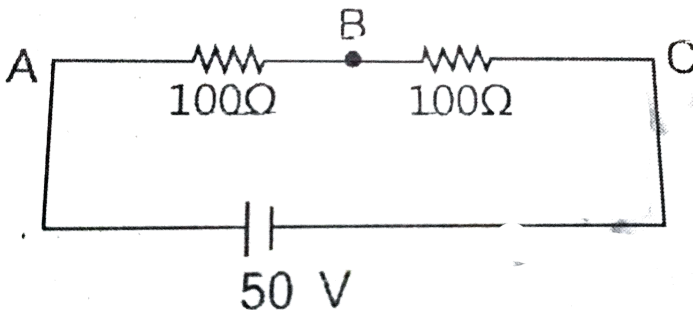

A voltmeter of resistance 150Ω is connected

across A and B. The potential drop across B and C measured by voltmeter is

A. 29 V

B. 27 V

C. 31 V

D. 30 V

Answer: C



View Text Solution

13. Two spherical nuclei have mass number 216 and 64 with their radii R_1 and R_2 respectively. The ratio, $\frac{R_1}{R_2}$ is equal to

A. 3 : 2

B. 1 : 3

C. 1 : 2

D. 2 : 3

Answer: A



Watch Video Solution

14. A massless rod S having length $2l$ has equal point masses attached to its two ends as shown in figure. The rod is rotating about an axis passing through its centre and making angle α with the axis. The magnitude of

change of momentum of rod i.e., $\left| \frac{dL}{dt} \right|$ equals

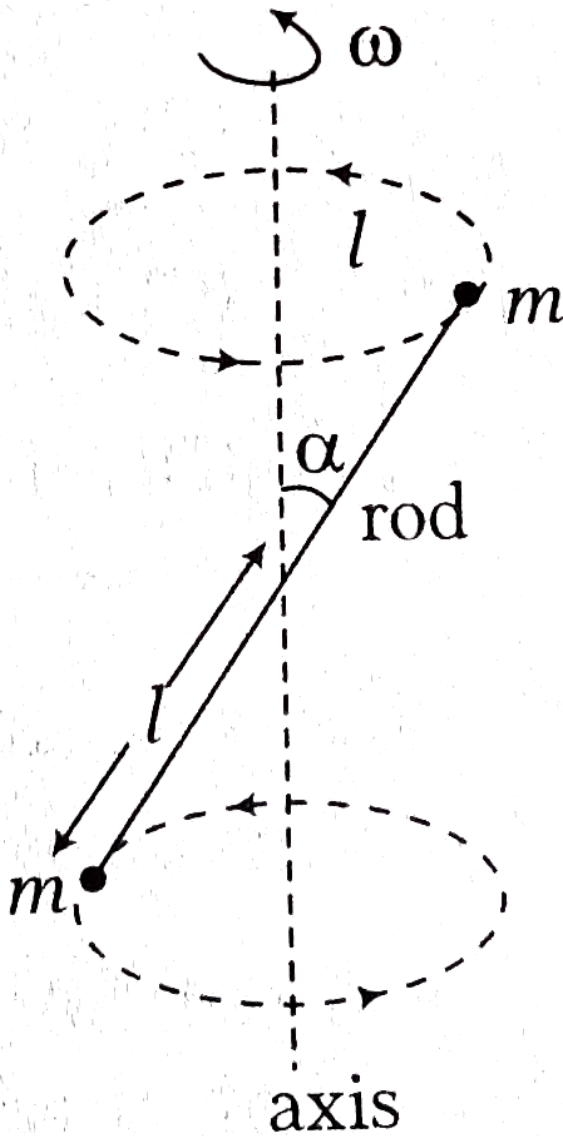

A. $2mI^3\omega^2 \sin \theta. \cos \theta$

B. $mI^2\omega^2 \sin 2\theta$

C. $mI^2 \sin 2\theta$

D. $m^{1/2}I^{1/2}\omega \sin \theta. \cos \theta$

Answer: B



Watch Video Solution

15. A semiconductor having electron and linear mobilities μ_n and μ_p respectively.

If its intrinsic carrier density is n_i , then what

will be the value of hole concentration P for which the conductivity will be maximum at a given temperature?

A. $n_i \sqrt{\frac{\mu_n}{\mu_p}}$

B. $n_h \sqrt{\frac{\mu_n}{\mu_p}}$

C. $n_i \sqrt{\frac{\mu_p}{\mu_n}}$

D. $n_h \sqrt{\frac{\mu_p}{\mu_n}}$

Answer: A



Watch Video Solution

16. In terms of basic units of mass (M), length (L), time (T), and charge (Q), the dimensions of magnetic permeability of vacuum (μ_0) would be

A. $[MLQ^{-2}]$

B. $[LT^{-1}Q^{-1}]$

C. $[ML^2T^{-1}Q^{-2}]$

D. $[LTQ^{-1}]$

Answer: A



Watch Video Solution

17. The black body spectrum of an object O_1 is such that its radiant intensity (i.e. intensity per unit wavelength interval) is maximum at a wavelength of 200 nm. Another object O_2 has the maximum radiant intensity at 600 nm. The ratio of power emitted per unit area by source O_1 to that of source O_2 is

A. 1:81

B. 1:9

C. 9:1

D. 81 : 1

Answer: D



Watch Video Solution

18. A beam of light of wavelength 400nm and power 1.55 mW is directed at the cathode of a photoelectric cell. If only 10% of the incident photons effectively produce photoelectrons, then find current due to these electrons.

(given

$$hc = 1240eV - nm, e = 1.6 \times 10^{-19} C)$$

A. $5\mu A$

B. $40\mu A$

C. $50\mu A$

D. $114\mu A$

Answer: C



Watch Video Solution

19. The molar specific heat of a gas as given from the kinetic theory is $\frac{5}{2}R$. If it is not specified whether it is C_p or C_v one could conclude that the molecules of the gas

- A. are definitely monoatomic
- B. are definitely rigid diatomic
- C. are defined non - rigid diatomic
- D. can be monoatomic or rigid diatomic

Answer: D



Watch Video Solution

20. When the tension in a metal wire is T_1 , its length is I_1 . When the tension is T_2 , its length is I_2 . The natural length of wire is

A. $\frac{I_1 + I_2}{2}$

B. $\sqrt{I_1 I_2}$

C. $\frac{I_2 T_2 - I_1 T_1}{T_2 - T_1}$

D. $\frac{I_1 T_2 + I_2 T_1}{T_1 + T_2}$

Answer: C





21. The velocity v and displacement x of a particle executing simple harmonic motion are related as

$$v \frac{dv}{dx} = -\omega^2 x.$$

At $x = 0$, $v = v_0$. Find the velocity v when the displacement becomes x .

A. $v = \sqrt{v_0^2 + \omega^2 x^2}$

B. $v = \sqrt{v_0^2 - \omega^2 x^2}$

C. $v = 3\sqrt{v_0^3 + \omega^3 x^3}$

$$D. v = v_0 - \left(\omega^3 x^3 e^{x^3} \right)^{1/3}$$

Answer: B



Watch Video Solution

22. Block A of mass m and block B of mass $2m$ are placed on a fixed triangular wedge by means of a massless inextensible string and a frictionless pulley as shown in figure. The wedge is inclined at 45° to the horizontal on both sides. The coefficient of friction between

blocks A and the wedge is $\frac{2}{3}$ and that between block B and is released from rest find the following

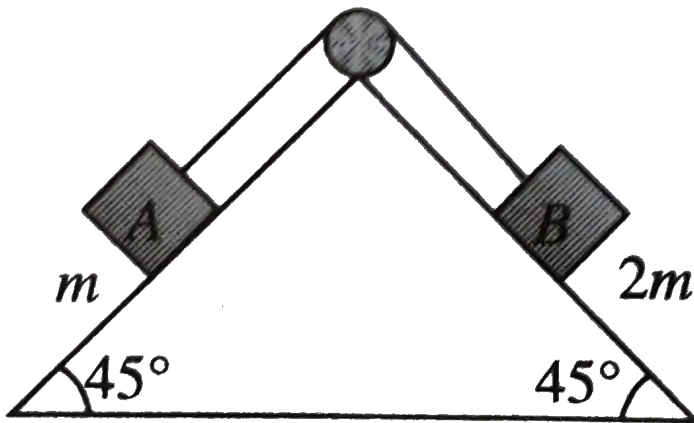

The tension in the string is

A. zero

B. $\frac{2m^2}{3}g$

C. $\frac{4m^2}{3}g$

D. $\frac{m^2}{\sqrt{2}}g$

Answer: A

 **Watch Video Solution**

23. In the arrangement shown in figure , the current through 5Ω resistor is

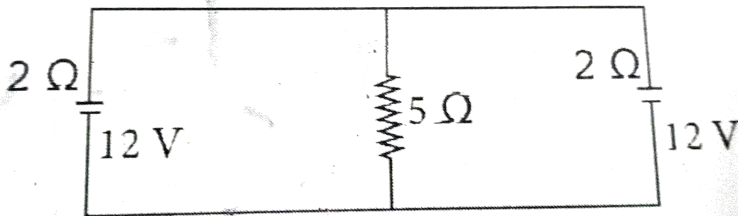

A. 2A

B. zero

C. $\frac{12}{7}A$

D. $1A$

Answer: A



View Text Solution

24. A hemispherical bowl of radius R is set rotating about its axis of symmetry which is kept vertical. A small block kept in the bowl rotates with the bowl without slipping on its

surface. If the surfaces of the bowl is smooth, and the angle made by the radius through the block with the vertical is θ , find the angular speed at which the bowl is rotating.

A. $\omega = \sqrt{rg \sin \theta}$

B. $\omega = \sqrt{g / r \cos \theta}$

C. $\omega = \sqrt{\frac{gr}{\cos \theta}}$

D. $\omega = \sqrt{\frac{gr}{\tan \theta}}$

Answer: B



Watch Video Solution

25. The phase difference between the flux linkage and the induced e.m.f. in a rotating coil in a uniform magnetic field

A. $\pi / 2$

B. $\pi / 3$

C. $-\pi / 6$

D. π

Answer: A



Watch Video Solution

26. A condenser of $250\mu F$ is connected in parallel to a coil of inductance $0.16mH$ while its effective resistance is 20Ω . Determine the resonant frequency

A. $9 \times 10^4 Hz$

B. $16 \times 10^7 Hz$

C. $8 \times 10^5 Hz$

D. $9 \times 10^3 Hz$

Answer: C



Watch Video Solution

27. The variation of magnetic susceptibility χ with the temperature T of a ferromagnetic material can be plotted as

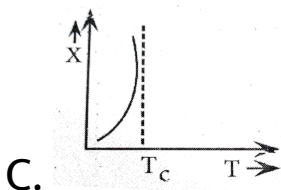
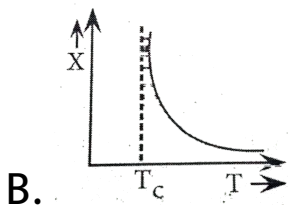
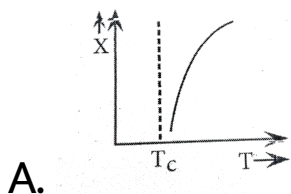

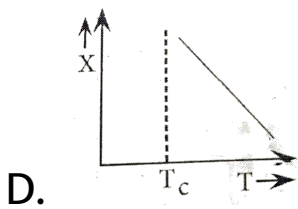

Answer: B



Watch Video Solution

28. For Bragg's diffraction by a crystal to occur, then the X-ray of wavelength λ and interatomic distance d must be

A. λ is greater than $2d$

B. λ equals $2d$

C. λ is smaller than or equal to $2d$

D. λ is smaller than $2d$

Answer: C



Watch Video Solution

29. A wire having mass m and length l can freely slide on a pair of parallel smooth horizontal rails placed in vertical magnetic field B . The rails are connected by a capacitor

of capacitance C . The electric resistance of the rails and the wire is zero. If a constant force F acts on the Wire as shown in the figure. Then the acceleration of the wire can be given as

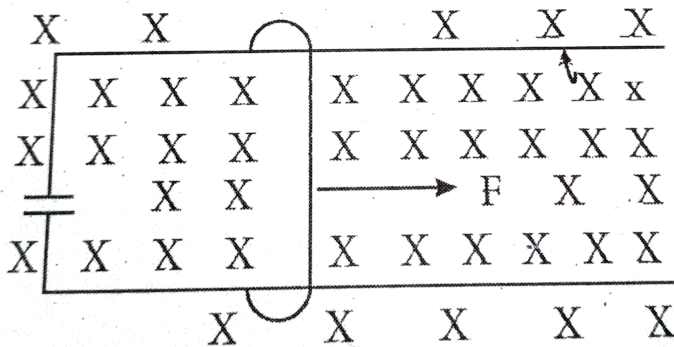

A. $a = \frac{C^2 B^2 l - F}{m}$

B. $a = \frac{F}{m + CBl}$

C. $a = \frac{FC^2 B^2 l}{m}$

D. $a = \frac{F}{m + C^2 B^2 l}$

Answer: D



View Text Solution

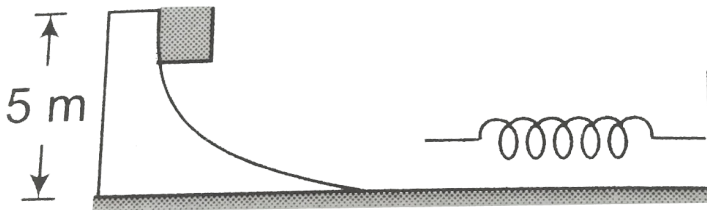

30.

The figure shows a smooth curved track terminating in a smooth horizontal part. A spring of spring constant $400(N)/(m)$ is attached at one end to a wedge fixed rigidly with the horizontal part . A 40 g mass is

released from rest at a height of 5 m on the curved track. The maximum compression of the spring will be

A. 9.8 m

B. 9.8 cm

C. .98 km

D. .009 km

Answer: B



Watch Video Solution

31. A block having mass m collides with another stationary block having mass $2m$. The lighter block comes to rest after collision. If the velocity of first block is v , then the value of coefficient of restitution will be

A. 0.5

B. 0.4

C. 0.6

D. 0.8

Answer: A



32. A uniform sphere of mass $500g$ rolls without slipping on a plane surface so that its centre moves at a speed of $0.02m/s$.

The total kinetic energy of rolling sphere would be (in J)

A. $1.4 \times 10^{-4} J$

B. $0.75 \times 10^{-3} J$

C. $5.75 \times 10^{-3} J$

D. $4.9 \times 10^{-5} J$

Answer: A



Watch Video Solution

33. A force $F = (10 + 0.5x)$ acts on a particle in the x -direction. What would be the work done by this force during a displacement from $x = 0$ to $x = 2m$ (F is in newton and x in metre)

A. 25 J

B. 29 J

C. 21 J

D. 18 J

Answer: C



Watch Video Solution

34. The reading of a spring balance corresponds to 100 N while situated at the north pole and a body is kept on it. The weight record on the same scale if it is shifted to the

equator, is (take, $g = 9.8 \text{ ms}^{-2}$ and radius of the earth, $R = 6.4 \times 10^6 \text{ m}$)

A. 99.66 N

B. 110 N

C. 97.66 N

D. 106 N

Answer: A



Watch Video Solution

35. If the intensity is increased by a factor of 20, by how many decibels is the intensity level increased.

A. 18

B. 13

C. 9

D. 7

Answer: B



Watch Video Solution

36. On the same path, the source and observer are moving such a way that the distance between these two increases with the time. The speeds of source and observer are same and equal to 10ms^{-1} with respect to the ground while no wind is blowing. The apparent frequency received by observer is 1950Hz then the original frequency must be (the speed of sound in present medium is 340m/s)

A. 2068 Hz

B. 2100 Hz

C. 1903 Hz

D. 602 Hz

Answer: A



Watch Video Solution

37. Consider the ray diagram for the refraction given Fig. The maximum value of angle θ for which the light suffers total internal reflection

at the vertical surface, is.

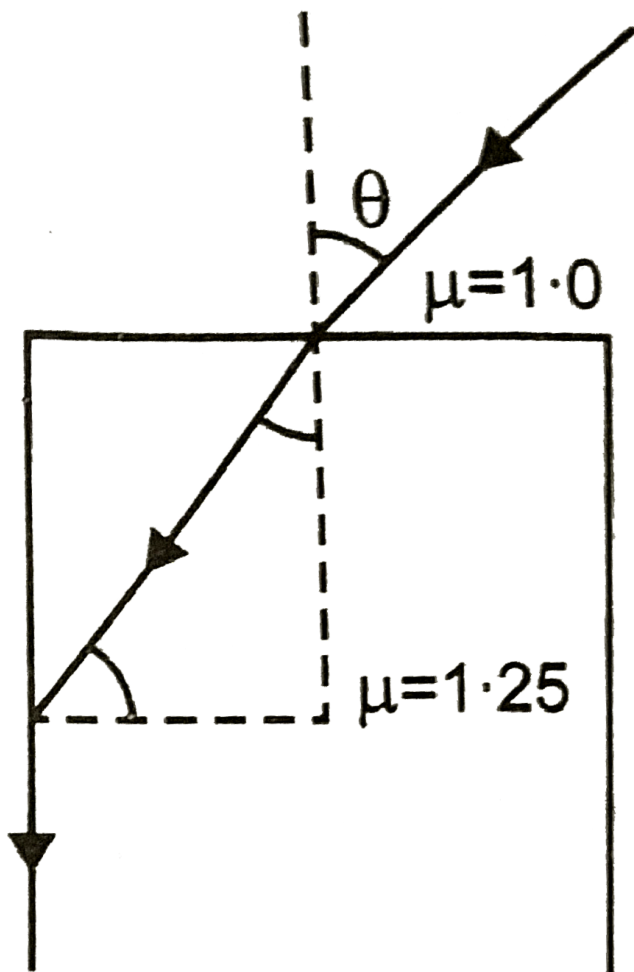

A. $\cos^{-1}\left(\frac{3}{4}\right)$

B. $\sin^{-1}\left(\frac{3}{4}\right)$

C. $\tan^{-1}\left(\frac{4}{3}\right)$

D. $\cos^{-1}\left(\frac{4}{3}\right)$

Answer: B



Watch Video Solution

38. The near point and far point of a person are 40cm and 250cm, respectively. Determine the power of lens he/she should use while reading a book kept at distance 25cm away from it,

A. 2.5 D

B. 5.0 D

C. 1.5 D

D. 3.5 d

Answer: C



Watch Video Solution

39. The dimensional formula of electric flux is

A. $[ML^3I^{-1}T^{-3}]$

B. $[M^2 L^2 I^{-1} T^{-2}]$

C. $[ML^3 I^1 T^{-3}]$

D. $[ML^{-3} I^{-1} T^{-3}]$

Answer: A



Watch Video Solution

40. An electron of mass m_e initially at rest moves through a certain distance in a uniform electric field in time t_1 . A proton of mass m_p also initially at rest takes time t_2 to move

through an equal distance in this uniform electric field. Neglecting the effect of gravity, the ratio of t_2 / t_1 is nearly equal to

A. 1

B. $\sqrt{\frac{M_p}{M_e}}$

C. $\sqrt{\frac{M_e}{M_p}}$

D. 1836

Answer: B



Watch Video Solution

41. STATEMENT-1 : In an elastic collision between two bodies, the relative speed of the bodies after collision is equal to the relative speed before the collision.

STATEMENT-2 : In an elastic collision, the linear momentum of the system is conserved.

A. If both Assertion and Reason are true and Reason is correct explanation of Assertion.

B. If both Assertion and Reason are true but Reason is not the correct explanation of Assertion.

C. If Assertion is true but Reason is false.

D. If both Assertion and Reason are false.

Answer: D



Watch Video Solution

42. Assertion : If there is no external torque on a body about its centre of mass, then the velocity of the centre of mass remains constant.

Reason : The linear momentum of an isolated system remains constant.

A. If both Assertion and Reason are true and Reason is correct explanation of Assertion.

B. If both Assertion and Reason are true but Reason is not the correct explanation of Assertion.

C. If Assertion is true but Reason is false.

D. If both Assertion and Reason are false.

Answer: D



Watch Video Solution

43. Assertion : An astronaut in an orbiting space station above the earth experience weightlessness.

Reason : An object moving around the earth under the influence of earth's gravitational force is in a state of 'free fall'

A. If both Assertion and Reason are true and Reason is correct explanation of Assertion.

B. If both Assertion and Reason are true but Reason is not the correct explanation of Assertion.

C. If Assertion is true but Reason is false.

D. If both Assertion and Reason are false.

Answer: A



Watch Video Solution

44. STATEMENT-1: The stream of water flowing at high speed from a garden hose pipe tends to spread like a fountain when held vertically up, but tends to narrow down when held vertically down.

STATEMENT-2: In any steady flow of an incompressible fluid, the volume flow rate of the fluid remains constant.

A. If both Assertion and Reason are true and Reason is correct explanation of Assertion.

B. If both Assertion and Reason are true but Reason is not the correct explanation of Assertion.

C. If Assertion is true but Reason is false.

D. If both Assertion and Reason are false.

Answer: A



Watch Video Solution

45. Assertion : The total translational kinetic energy of all the molecules of a given mass of an ideal gas is 1.5 times the product of its pressure and volume.

Reason : The molecules of gas collide with each other and the velocities of the molecules change due to the collision.

A. If both Assertion and Reason are true and Reason is correct explanation of Assertion.

B. If both Assertion and Reason are true but Reason is not the correct explanation of Assertion.

C. If Assertion is true but Reason is false.

D. If both Assertion and Reason are false.

Answer: B



Watch Video Solution

46. Statement-1 The formula connecting u, v and f for a spherical mirror is valid only for mirrors whose sizes are very small compared to their radii of curvature. Because

Statement-2

Laws of reflection are strictly valid for plane surfaces, but not for large spherical surfaces.

A. If both Assertion and Reason are true and Reason is correct explanation of Assertion.

B. If both Assertion and Reason are true but Reason is not the correct explanation of Assertion.

C. If Assertion is true but Reason is false.

D. If both Assertion and Reason are false.

Answer: A



Watch Video Solution

47. Statement-1 : In a Meter Bridge experiment, null point for an unknown resistance is measured. Now, the unknown resistance is put inside an enclosure maintained at a higher temperature. The null point can be obtained at the same point as before by decreasing the value of the standard resistance.

Statement-2 : Resistance of metal increases with increase in temperature.

A. If both Assertion and Reason are true
and Reason is correct explanation of

Assertion.

B. If both Assertion and Reason are true but Reason is not the correct explanation of Assertion.

C. If Assertion is true but Reason is false.

D. If both Assertion and Reason are false.

Answer: D



Watch Video Solution

48. Assertion: Forces acting between proton-proton (f_{pp}), proton -neutron (f_{pn}) and neutron -neutron (f_{nn}) are such that $f_{pp} < f_{pn} = f_{nn}$.

Reason: Electrostatic force of repulsion between two proton reduces net nuclear forces between them.

A. If both Assertion and Reason are true and Reason is correct explanation of Assertion.

B. If both Assertion and Reason are true but Reason is not the correct explanation of Assertion.

C. If Assertion is true but Reason is false.

D. If both Assertion and Reason are false.

Answer: A



Watch Video Solution

49. Assertion (A) The magnetic moment (μ) of an electron revolving around the nucleus decreases with increasing principle quantum number (n).

Reason (R) Magnetic moment of the revolving electron , $\mu \propto n$.

A. If both Assertion and Reason are true and Reason is correct explanation of Assertion.

B. If both Assertion and Reason are true but Reason is not the correct explanation of Assertion.

C. If Assertion is true but Reason is false.

D. If both Assertion and Reason are false.

Answer: D



View Text Solution

50. Assertion: A particle of mass M at rest decays into two particles of masses m_1 and m_2 , having non-zero velocities will have ratio of the de-broglie wavelength unity.

Reason: Here we cannot apply conservation of linear momentum.

A. If both Assertion and Reason are true and Reason is correct explanation of Assertion.

B. If both Assertion and Reason are true but Reason is not the correct explanation of Assertion.

C. If Assertion is true but Reason is false.

D. If both Assertion and Reason are false.

Answer: C



Watch Video Solution

51. Assertion (A) To increase resolving power of a telescope, the aperture (a) of the object should be large.

Reason (R) Resolving power of the telescope is given by $\frac{2a}{1.22\lambda}$.

A. If both Assertion and Reason are true and Reason is correct explanation of Assertion.

B. If both Assertion and Reason are true but Reason is not the correct

explanation of Assertion.

C. If Assertion is true but Reason is false.

D. If both Assertion and Reason are false.

Answer: C



Watch Video Solution

52. Assertion (A) If the frequency of the applied AC is doubled , then the power factor of a series R-L circuit decreases.

Reason (R) Power factor of series R-L circuit is

given by $\cos \theta = \frac{2R}{\sqrt{R^2 + \omega^2 L^2}}$

A. If both Assertion and Reason are true and Reason is correct explanation of Assertion.

B. If both Assertion and Reason are true but Reason is not the correct explanation of Assertion.

C. If Assertion is true but Reason is false.

D. If both Assertion and Reason are false.

Answer: C



Watch Video Solution

53. Assertion: Above Curie temperature, a ferromagnetic material becomes paramagnetic.

Reason: When a magnetic material is heated to very high temperature, it loses its magnetic properties.

A. If both Assertion and Reason are true and Reason is correct explanation of Assertion.

B. If both Assertion and Reason are true but Reason is not the correct explanation of Assertion.

C. If Assertion is true but Reason is false.

D. If both Assertion and Reason are false.

Answer: A



Watch Video Solution

54. Assertion: A charge moving in a circular orbit can produce em wave.

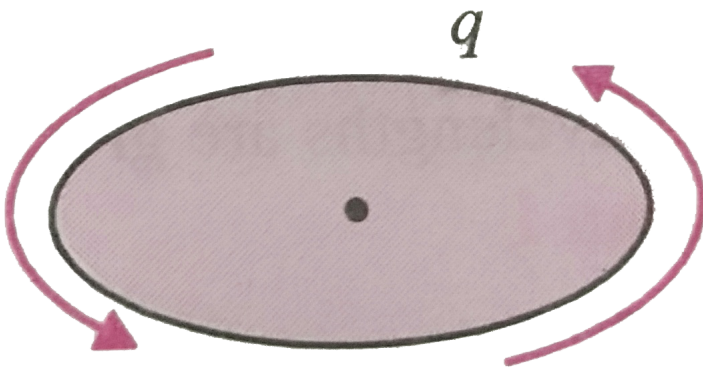

Reason: The source of em wave should be in accelerated motion.

A. If both Assertion and Reason are true and Reason is correct explanation of

Assertion.

B. If both Assertion and Reason are true but Reason is not the correct explanation of Assertion.

C. If Assertion is true but Reason is false.

D. If both Assertion and Reason are false.

Answer: A



Watch Video Solution

55. Assertion. The bar magnet falling vertically along the axis of the horizontal coil will be having acceleration less than g .

Reason. Clockwise current induced in the coil.

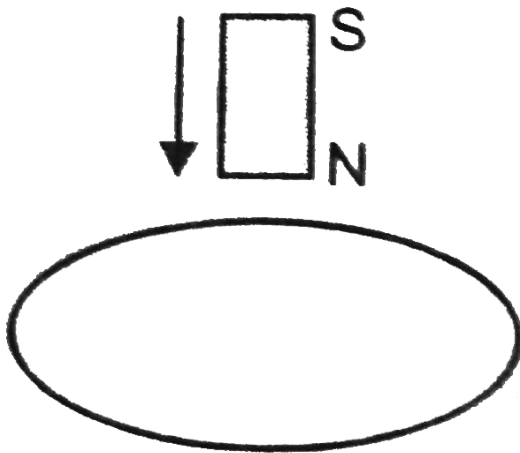

A. If both Assertion and Reason are true and Reason is correct explanation of Assertion.

B. If both Assertion and Reason are true but Reason is not the correct explanation of Assertion.

C. If Assertion is true but Reason is false.

D. If both Assertion and Reason are false.

Answer: C



Watch Video Solution

56. Assertion (A) The effective resistance of the network between P and Q is $\frac{4}{5}r$.

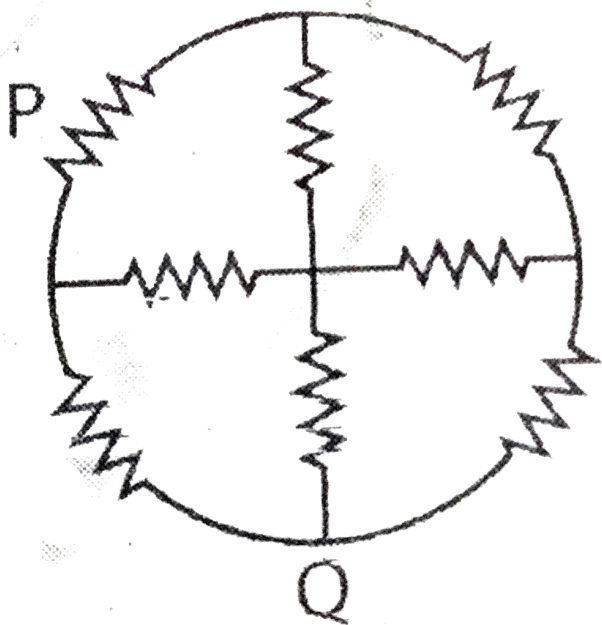

Reason (R) Symmetry can be applied to be network with respect to centre.

A. If both Assertion and Reason are true and Reason is correct explanation of Assertion.

B. If both Assertion and Reason are true but Reason is not the correct explanation of Assertion.

C. If Assertion is true but Reason is false.

D. If both Assertion and Reason are false.

Answer: D



View Text Solution

57. Assertion (A) A spherical equipotential surface is not possible for a point charge.

Reason (R) A spherical equipotential surface is possible inside a spherical capacitor.

A. If both Assertion and Reason are true and Reason is correct explanation of Assertion.

B. If both Assertion and Reason are true but Reason is not the correct

explanation of Assertion.

C. If Assertion is true but Reason is false.

D. If both Assertion and Reason are false.

Answer: D



View Text Solution

58. Assertion (A) A wire bent into an irregular shape with the point P and Q fixed . If a current I passed through the Wire, then the area enclosed by the irregular portion of the

Wire increases.

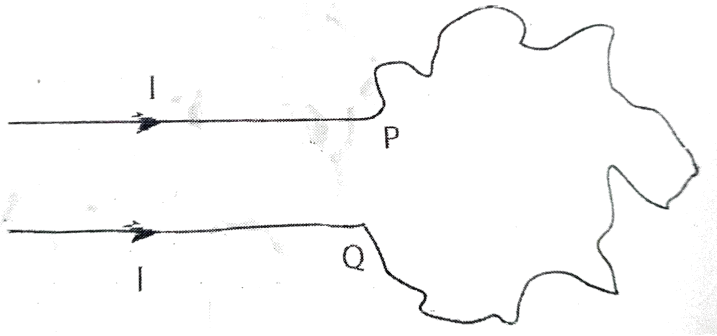

Reason (R) Opposite currents carrying Wires
repel each other.

A. If both Assertion and Reason are true
and Reason is correct explanation of
Assertion.

B. If both Assertion and Reason are true
but Reason is not the correct

explanation of Assertion.

C. If Assertion is true but Reason is false.

D. If both Assertion and Reason are false.

Answer: A



View Text Solution

59. Assertion (A) A charge q is placed on a height $h/4$ above the centre of a square of side b . The flux associated with the square is independent of side length.

Reason (R) Gauss 's law is independent of size of the Gaussian surface.

A. If both Assertion and Reason are true and Reason is correct explanation of Assertion.

B. If both Assertion and Reason are true but Reason is not the correct explanation of Assertion.

C. If Assertion is true but Reason is false.

D. If both Assertion and Reason are false.

Answer: A



Watch Video Solution

60. Assertion. Audio signal of frequency 10 KHz cannot be transmitted over long distance without modulation.

Reason. Length of the antenna required $\lambda/4$.

Should have practical value.

A. If both Assertion and Reason are true

and Reason is correct explanation of

Assertion.

B. If both Assertion and Reason are true but Reason is not the correct explanation of Assertion.

C. If Assertion is true but Reason is false.

D. If both Assertion and Reason are false.

Answer: A



Watch Video Solution