



PHYSICS

BOOKS - AIIMS PREVIOUS YEAR PAPERS

AIIMS 2018 PAPER 1

Physics

1. In the diagram 100kg block is moving up with constant velocity, then find out the

tension at point P :

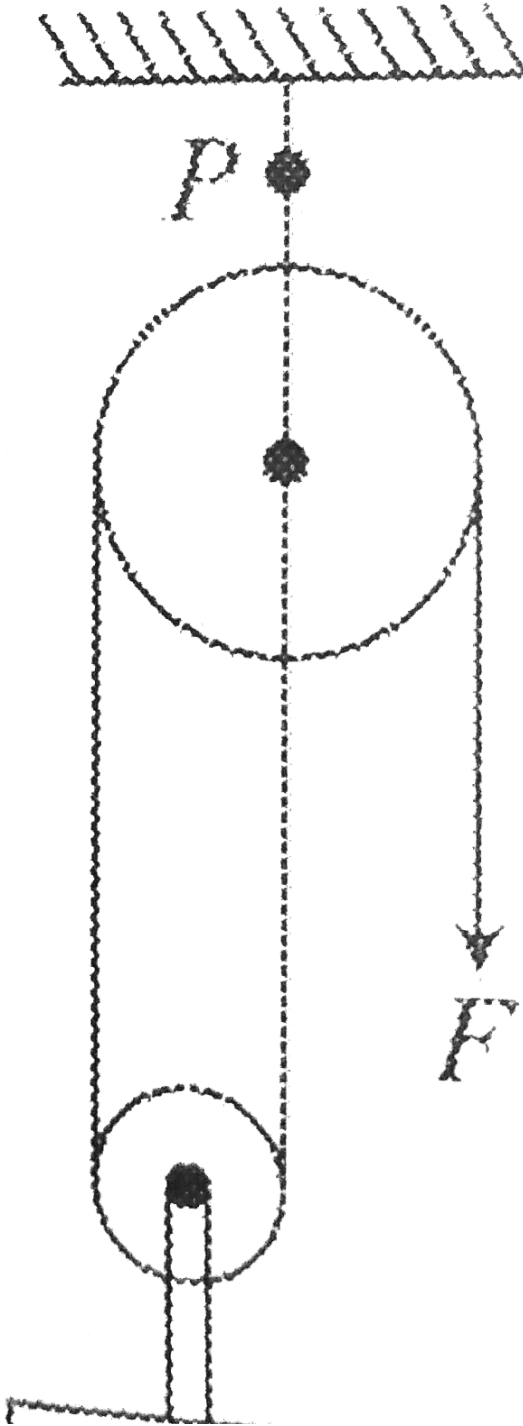

100 kg



Watch Video Solution

2. In a simple microscope of focal length 5cm final image is formed at D , then its magnification will be

A. 6

B. 5

C. 2

D. 1

Answer: A



Watch Video Solution

3. Centre of mass of a ring will be at a position:



View Text Solution

4. In a full wave rectifiers in which input voltage is represented by $V = V_M \sin \omega t$, then peak inversion voltage of non-conducting diode will be

A. $-V_M$

B. $V_M / 2$

C. $2V_M$

D. 0

Answer: C



Watch Video Solution

5. A long cylindrical wire carrying current of $10A$ has radius of $5mm$ find its its magnetic field induction at a point $2mm$ from the centre of the wire

A. $16 \times 10^{-4}T$

B. $2.4 \times 10^{-4}T$

C. $3.2 \times 10^{-4}T$

D. $0.8 \times 10^{-4}T$

Answer: A



Watch Video Solution

6. A parallel plate capacitor of $1\mu F$ capacity is discharging through a resistor. If its energy reduces to half in one second. The value of resistance will be

A. $\frac{2}{\ln(2)} M\Omega$

B. $\frac{4}{\ln(2)} M\Omega$

C. $\frac{0}{\ln(2)} M\Omega$

D. $\frac{16}{\ln(2)} M\Omega$

Answer: A



Watch Video Solution

7. Water is flowing in a non viscous tube as shown in the diagram. The diameter at a point A and B are 0.5m and 0.1m respectively. The pressure difference between points A & B are

$\Delta P = 0.8$ then find out the rate of flow:

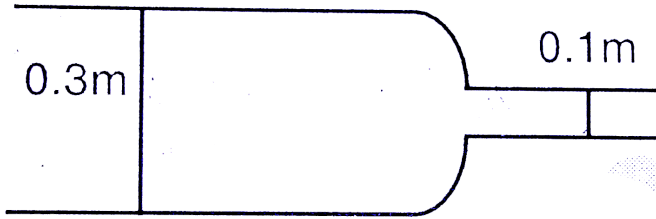

[View Text Solution](#)

8. Biot Savart law of magnetism is analogous to:



[Watch Video Solution](#)

9. In an electromagnetic wave the expression for electric field is given by $E = 50 \sin(\omega t - kx)$ the permeability is given $\mu = 4\mu_0$ & permittivity $\epsilon_0 = \epsilon_r$, then find the average intensity delivered.

A. 1

B. 2

C. 3

D. 4

Answer:



Watch Video Solution

10. In the diagram find out the current through 2Ω (R_3) :

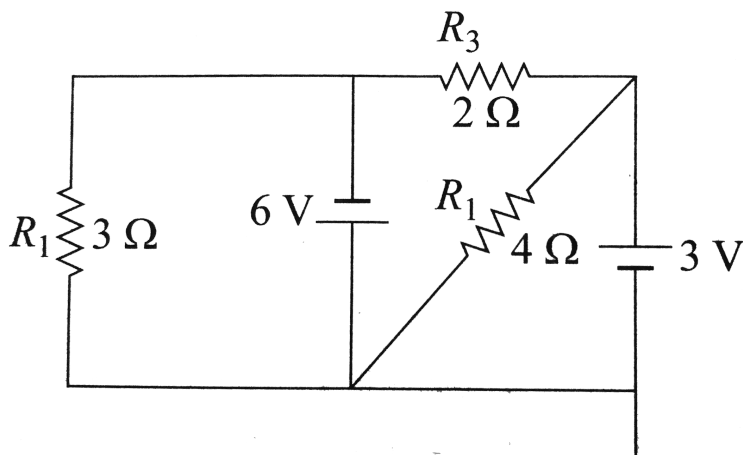

Watch Video Solution

11. An N-P-N transistor is connected in common emitter configuration in which collector supply is 9V and the voltage drop across the load resistance of 1000Ω connected in the collector circuit is 1V. If current amplification factor is $(25/26)$, If the internal following options is incorrect.

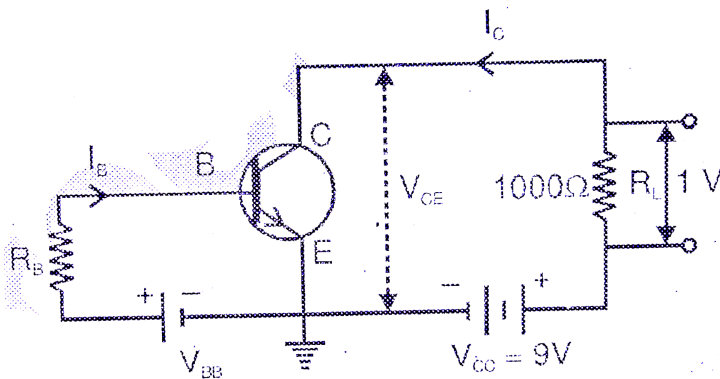

Watch Video Solution

12. In a hydrogen spectrum third line of Balmer's series having wavelength λ . Find the binding energy of the ground state.



[Watch Video Solution](#)

13. A wire of some length is bent in the form of a ring of diameter $2a$ having self inductance L , then L will depend upon a as:



[Watch Video Solution](#)

14. What will be the position of centre of mass of a half disc shown ?

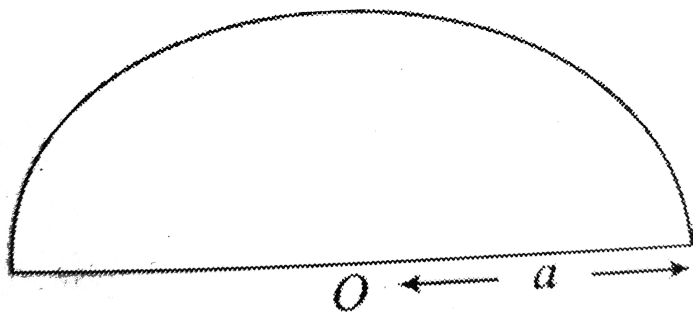

A. $\frac{2a}{\pi}$

B. $\frac{4a}{3\pi}$

C. $\frac{a}{\pi}$

D. $\frac{2a}{3\pi}$

Answer:



Watch Video Solution

15. In a LCR series resonating circuit. Give the value of average power loss.



Watch Video Solution

16. Find the minimum wavelength of X - ray emitted by X - ray tube , which is operating at $15kV$ accelerating voltage.



[Watch Video Solution](#)

17. A galvanometer gives full scale deflection of 1 volt when acting like a voltmeter when connected in series with $2k\Omega$ resistance. The same galvanometer gives $500mA$, full scale deflection when acting like a ammeter when connected with shunt resistance of value 0.2Ω in parallel. Find out the resistance of galvanometer.



[Watch Video Solution](#)

18. A uniformly charged non conducting disc with surface charge density $10nC/m^2$ having radius $R = 3cm$. Then find the value of electric field intensity at a point on the perpendicular bisector at a distance of

$$r = 2\text{cm}$$

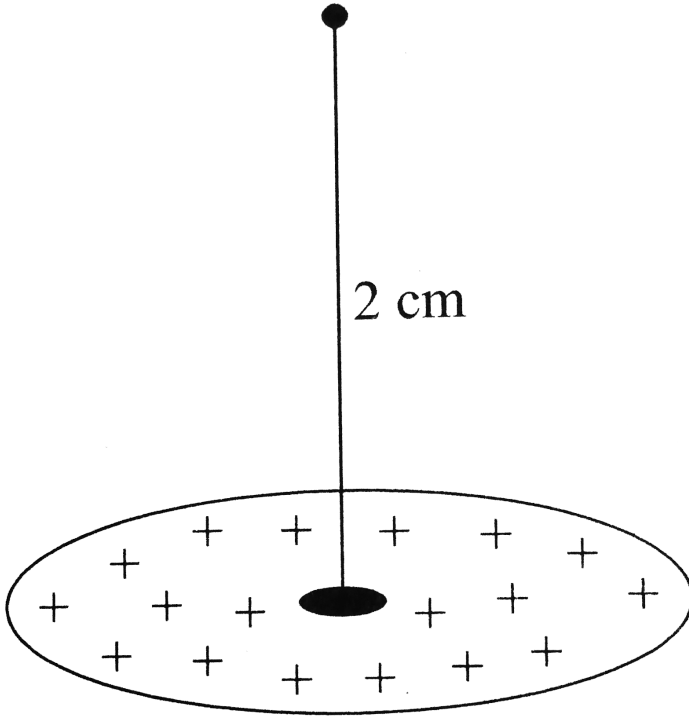

[Watch Video Solution](#)

19. Two small balls, each having equal positive charge Q are suspended by two insulating

strings of equal length l from a hook fixed to a stand. The mass of each ball = m and the total angle between the two strings is 60° , then find the charge on each ball.

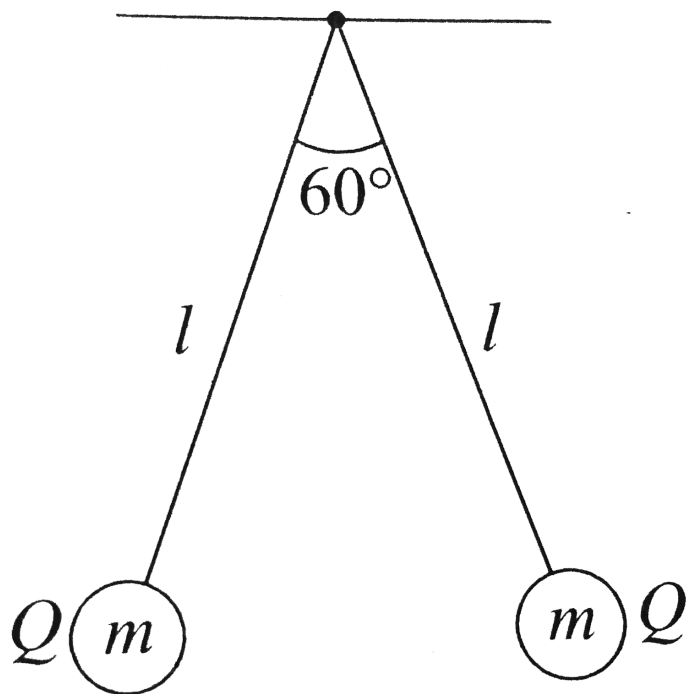

[Watch Video Solution](#)

20. A magnetic material is placed in a non-uniform magnetic field which is orienteiong z-axis having then force gradient $= \frac{dH}{dz}$, experienced by the material will be equal to



[Watch Video Solution](#)

21. A Rocket having initial mass $5 \times 10^6 kg$, which include mass of fuel of mass $4 \times 10^6 kg$ is ejecting gas with velocity $4000m / s$ relative

to Rocket. Then what will be the velocity of rocket when entire fuel finishes?



[Watch Video Solution](#)

22. In a single slit diffraction method, the distance between slit and screen is $1m$. The size of the slit is $0.7mm$ and second maximum is formed at the distance of $2mm$ from the centre of the screen, then find out the wavelength of light.



[Watch Video Solution](#)

23. In a solar cell, current is generated due to bond breakage in which region?

A. depletion region

B. n-region

C. p-region

D. None of these

Answer:



Watch Video Solution

24. In a modulated signal the maximum amplitude is 15 Volt and minimum amplitude is 5 Volt, then amplitude of signal wave will be:



[Watch Video Solution](#)

25. In a series LR circuit ($L = 3H$, $R = 1.5\Omega$) and DC voltage = $1V$. Find current at $T = 2$ seconds.



[Watch Video Solution](#)

26. One gram of water (1cm^3) becomes 1671cm^3 of steam when boiled at a constant pressure of 1 atm ($1.013 \times 10^5 \text{Pa}$). The heat of vaporization at this pressure is $L_v = 2.256 \times 10^6 \text{J/kg}$. Compute (a) the work done by the water when it vaporizes and (b) its increase in internal energy.



Watch Video Solution

27. In the figure shown S is the source of white light kept at a distance x_0 from the plane of

the slits. The source moves with a constant speed u towards the slits on the line perpendicular to the plane of the slits and passing through the slit S_1 . Find the instantaneous velocity (magnitude and direction) of the central maxima at time t having range $0 \leq t < \frac{x_0 - d}{u}$. Assume

that $D > > d$.

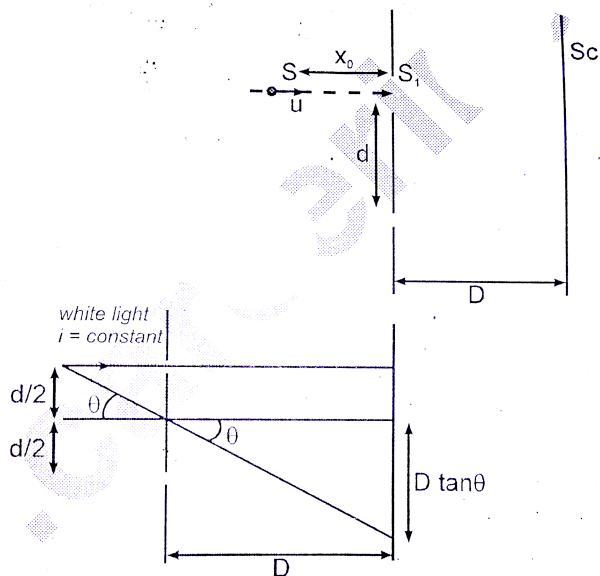

 [View Text Solution](#)

28. Light is incident on a polarizer with intensity I_0 . A second prism called analyzer is kept at a angle of 15° , from the first polarizer

then the intensity of final emergent light will be

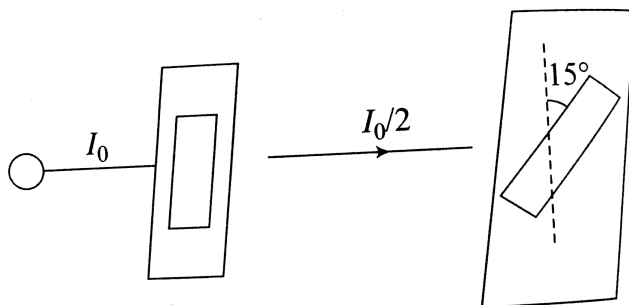

[Watch Video Solution](#)

29. A satellite orbiting certain planet has apogee R_1 and perigee equal to R_2 , then find the minimum kinetic energy that should be

given to the satellite to enable it to escape the
plane.



[View Text Solution](#)

30. Assertion : Rainy clouds appear dark from
below.

Reason : There is not sufficient light which
can be scattered by these clouds.

A. If both assertion and reason are true
and reason is the correct explanation of

assertion.

B. If both assertion and reason are true but reason is not the correct explanation of assertion.

C. If assertion is true but reason is false.

D. If both assertion and reason are false.

Answer: A



Watch Video Solution

31. Assertion: Magnetic field can not change the kinetic energy of moving charges.

Reason: Magnetic field can not change velocity vector.

A. If both assertion and reason are true and reason is the correct explanation of assertion.

B. If both assertion and reason are true but reason is not the correct explanation of assertion.

C. If assertion is true but reason is false.

D. If both assertion and reason are false,

Answer: C



Watch Video Solution

32. Assertion: Net electric field inside conductor is zero

Reason: Total positive charge equals to total negative charge in a conductor

A. If both assertion and reason are true and reason is the correct explanation of assertion.

B. If both assertion and reason are true but reason is not the correct explanation of assertion.

C. If assertion is true but reason is false.

D. If both assertion and reason are false.

Answer: C



Watch Video Solution

33. Assertion: All the charge in a conductor gets distributed on whole of its outer surface.

Reason: In a dynamic system, charges try to keep their potential energy minimum.

A. If both assertion and reason are true and reason is the correct explanation of assertion.

B. If both assertion and reason are true but reason is not the correct explanation of

assertion.

C. If assertion is true but reason is false.

D. If both assertion and reason are false.

Answer: A



Watch Video Solution

34. Assertion: Water waves in a river are not polarized.

Reason: Water waves are longitudinal in nature.

A. If both assertion and reason are true and reason is the correct explanation of assertion.

B. If both assertion and reason are true but reason is not the correct explanation of assertion.

C. If assertion is true but reason is false.

D. If both assertion and reason are false.

Answer: A



Watch Video Solution

35. Assertion: In a string wave, during reflection from fix boundary, the reflected wave is inverted.

Reason: The force on string by clamp is in downward direction while string is pulling the clamp is upward direction.

A. If both assertion and reason are true and reason is the correct explanation of assertion.

B. If both assertion and reason are true but reason is not the correct explanation of assertion.

C. If assertion is true but reason is false.

D. If both assertion and reason are false.

Answer: A



Watch Video Solution

36. Assertion : Surface tension decreases with increase in temperature.

Reason : On increasing temperature kinetic energy increases and intermolecular forces decrease.

A. If both assertion and reason are true and reason is the correct explanation of assertion.

B. If both assertion and reason are true but reason is not the correct explanation of

assertion.

C. If assertion is true but reason is false.

D. If both assertion and reason are false.

Answer: A



Watch Video Solution

37. Torque on a body can be zero even if there is a net force on it.

Torque and force on a body are always perpendicular.

A. If both assertion and reason are true and reason is the correct explanation of assertion.

B. If both assertion and reason are true but reason is not the correct explanation of assertion.

C. If assertion is true but reason is false.

D. If both assertion and reason are false.

Answer: B



Watch Video Solution

