



CHEMISTRY

BOOKS - MTG CHEMISTRY (ENGLISH)

SURFACE CHEMISTRY

Mcqs

1. After the reaction is over between adsorbed reactants, it is important to create space for the other reactant molecules to approach the surface and react. The process responsible for this is known as

- A. sorption
- B. desorption
- C. physisorption
- D. chemisorption

Answer: B



[Watch Video Solution](#)

2. Which of the following statements does not show correct difference between adsorption and absorption ?

- A. In adsorption , the substance is concentrated only at the surface while in absorption it is uniformly distributed in the bulk.
- B. Adsorption is instantaneous while absorption is a slow process.
- C. A substance can be adsorbed as well as absorbed simultaneously and the process is called sorption.
- D. Only gases are adsorbed while solids and liquids are absorbed.

Answer: D



[Watch Video Solution](#)

3. Why are powdered substance more effective as adsorbents than their crystalline forms ?

- A. adsorption is an exothermic process
- B. they become inert and do not react with the adsorbate
- C. the extent of adsorption increases with increases in surface area of the adsorbent
- D. adsorption is more if the size of adsorbent is small.

Answer: C



Watch Video Solution

4. अधिशोषक के सक्रियण से आप क्या समझते हैं? यह कैसे प्राप्त किया जाता है?

- A. adsorption power is increased by increasing surface area by making the surface rough.

- B. adsorption power is increased by dipping the surface in acid to make it smooth
- C. adsorption power is increased by dissolving it in water
- D. adsorption power is decreased to reduce the extent of adsorption

Answer: A

 [Watch Video Solution](#)

5. Fill in the blanks by putting appropriate choices. During adsorption there is _____ in enthalpy and _____ in the entropy of a system by adsorption is a spontaneous process and thus ΔG must be _____. Rate of physisorption _____ with increase in pressure.

- A. decrease, decrease, negative, increase
- B. increase, increase, positive, decrease
- C. decrease, increase, negative, decrease
- D. increase, decrease, positive, increase

Answer: A



[Watch Video Solution](#)

6. Which of the following is less than zero during adsorption?

A. ΔG

B. ΔS

C. ΔH

D. All of these.

Answer: D



[Watch Video Solution](#)

7. Physisorption

A. High specificity

- B. Irreversibility
- C. Non-specificity
- D. None of these

Answer: C

 [Watch Video Solution](#)

8. Which of the following statements is incorret about physisorption?

- A. It is a reversible process.
- B. It requires less heat of adsorption .
- C. It requires activation energy.
- D. It takes place at low temperature

Answer: C

 [Watch Video Solution](#)

9. The incorrect statement about physical adsorption is

- A. it lacks specificity
- B. it is generally reversible
- C. porous surfaces are good adsorbent
- D. heat of adsorption is quite high.

Answer: D



[Watch Video Solution](#)

10. Which is correct in case of van der Waals adsorption?

- A. High temperature, low pressure
- B. High temperature ,high pressure
- C. Low temperature , low pressure
- D. Low temperature , high pressure

Answer: D



Watch Video Solution

11. Adsorption is accompanied by the evolution of heat. Thus, according to Le Chatelier's principle the amount of surface adsorbed should

- (i) decrease with increase in temperature
- (ii) decrease with decrease in temperature
- (iii) increase with increase in temperature
- (iv) increase with decrease in temperature

A. increase with decrease in temperature

B. increase with increase in temperature

C. decrease with decrease in temperature

D. be equal at all temperature

Answer: A



Watch Video Solution

12. Which of the following gases is adsorbed most by activated charcoal?

A. HCl

B. NH_3

C. O_2

D. CO_2

Answer: C



Watch Video Solution

13. Which of the following is not a characteristic of chemisorption?

A. Adsorption is specific

B. Heat of adsorption is of the order of 200 KJ mol^{-1}

C. Adsorption is irreversible.

D. Adsorption may be multimolecular layers.

Answer: D



[Watch Video Solution](#)

14. Chemisorption involves formation of bond between gaseous molecules or atoms and the solid surface for which high energy is required. Thus it is also referred as

- A. Chemical adsorption
- B. positive adsorption
- C. activated adsorption
- D. passive adsorption

Answer: C



[Watch Video Solution](#)

15. Which of the following is not correct regarding the adsorption of a gas on the surface of solid ?

- A. 1. On increasing pressure, adsorption keeps on increasing
- B. 2. Enthalpy and entropy changes are negative
- C. 3. Chemisorption is more specific than physisorption
- D. 4. It is a reversible reaction.

Answer: A

 [Watch Video Solution](#)

16. Which plot is the adsorption isobar for chemisorption?

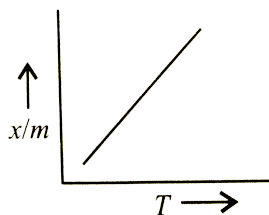

A.

B.

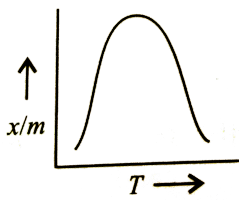

C.

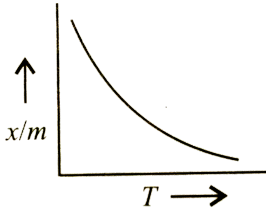

D.

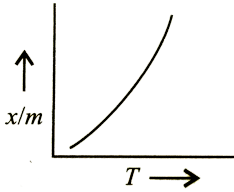

Answer: B



[Watch Video Solution](#)

17. Which of the following statements is not correct for chemisorption and physisorption ?

A.1. Physical adsorption occurs at a low temperature and chemisorption occurs at all temperature

- B. 2. Magnitude of chemisorption decreases with rise in temperature while physisorption increases with rise in temperature .
- C. 3. Chemisorption is irreversible and physisorption is reversible .
- D. 4. In physisorption, activation energy is low while in chemisorption, it is high.

Answer: B

 [Watch Video Solution](#)

18. In the adsorption of a gas on soil, Freundlich isotherm is obeyed .

The slope of the plot is zero. Thus, the extent of adsorption is

- A. directly proportional to the pressure of gas
- B. inversely proportional to the pressure of the gas.
- C. independent of the pressure of the gas.
- D. proportional to the square of the pressure of the gas.

Answer: C



Watch Video Solution

19. For Freundlich adsorption isotherm, $\frac{x}{m} = kp^1/n$, the value of n is

- A. 1. always greater than one
- B. 2. always smaller than one
- C. 3. always equal to one
- D. 4. greater than one at low temperature and smaller than one at high temperature.

Answer: A



Watch Video Solution

20. Which of the following graph yield a straight line?

A. x/m vs p

B. $\log x/m$ vs p

C. x/m vs $\log p$

D. $\log x/m$ vs $\log p$

Answer: D



Watch Video Solution

21. Observe the given adsorption isotherm carefully and choose the correct option

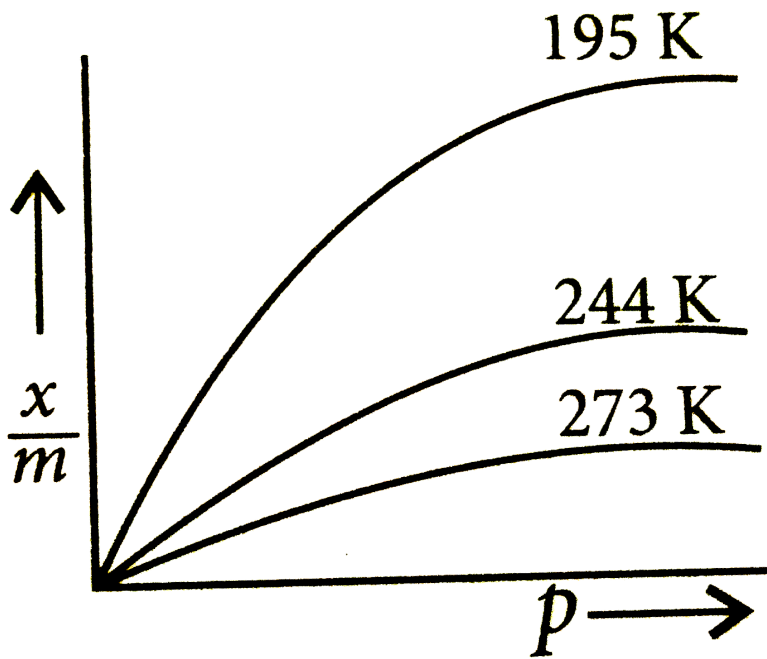

(i) These curves indicate that at a fixed temperature, there is a decrease in physical adsorption with increase in pressure.

(ii) These curves always seem to approach saturation at high pressure.

$\frac{x}{m} = k \cdot p^{1/n} (n > 1)$ is generally represented by this isotherm.

(iv) These curves indicate that at a fixed pressure, there is a decrease in physical adsorption with increase in temperature.

A. (i) and (iii) only

B. (ii) and (iv) only

C. (ii), (iii) and (iv) only

D. All of these.

Answer: C

 Watch Video Solution

22. A graph is plotted between $\log (x/m)$ and $\log p$ according to the equation $\frac{x}{m} = kp^{1/n}$

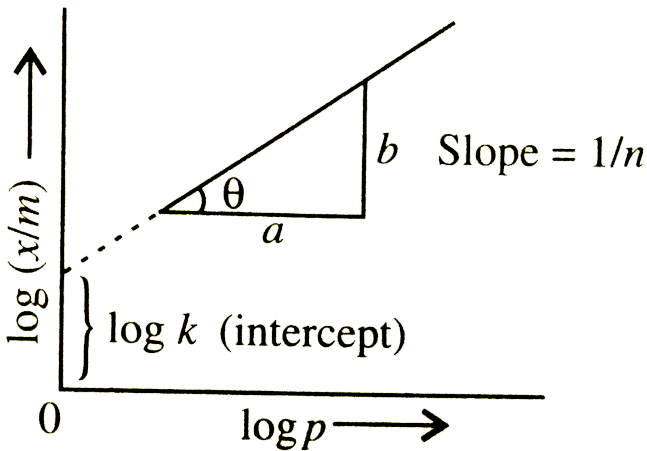

Which of the following statements about this graph is not correct ?

- A. The figure shows Freundlich adsorption isotherm
- B. The figure shows Langmuir adsorption isotherm

C. The adsorption varies directly with pressure

D. The factor $1/n$ can have values between 0 and 1.

Answer: B

 [Watch Video Solution](#)

23. At low pressure, the fraction of the surface covered follows.

A. zero-order kinetics

B. first order kinetics

C. second order kinetics

D. fractional order kinetics

Answer: B

 [Watch Video Solution](#)

24. What is the role of activated charcoal in gas mask used in coal mines?

- A. It acts as an adsorbent for poisonous gases
- B. It acts as an adsorbent for coal particles present in coal mines.
- C. It acts as a mask through which exhaled gases and diffused out.
- D. It acts as a base for scattering the light.

Answer: A



[Watch Video Solution](#)

25. Which of the following gases present in a polluted area will be absorbed most easily on the charcoal gas mask ?

- A. H_2
- B. O_2
- C. N_2
- D. SO_2

Answer: D



[Watch Video Solution](#)

26. Which of the following is/are application(s) of adsorption?

- A. Adsorption indicators
- B. Thin layer chromatography
- C. Qualitative analysis
- D. All of these.

Answer: D



[Watch Video Solution](#)

27. Why is froth floatation process selected for the concentration of the sulphide ore ?

- A. Shape selective catalysts
- B. Adsorption of pine oil on sulphide ore particles
- C. Adsorption of pine oil on impurities
- D. Production of heat in the process of exothermic reaction.

Answer: B

 [Watch Video Solution](#)

28. Which of the following statements are correct about solid catalyst?

- A. Catalyst is required in equal amount as the reactants present in the reaction.
- B. Catalytic activity of a solid catalyst does not depend upon the extent of chemisorption.
- C. Desorption is not important for a solid to act as good catalyst

D. Same reactant may give different products by using different catalysts.

Answer: D

 [Watch Video Solution](#)

29. Which can adsorb large volume of hydrogen gas ?

- A. Finely divided platinum
- B. Colloidal solution of palladium
- C. Small pieces of palladium
- D. A single metal surface of platinum

Answer: B

 [Watch Video Solution](#)

30. Traces of molybdenum are used with finely divided iron which acts as a catalyst during Haber's process for synthesis of ammonia . The Mo

- A. acts as a promoter to increase the activity of the catalyst
- B. acts as a poison to decrease the activity of the catalyst
- C. provides a new pathway to the reaction
- D. forms another intermediate compound with lesser activation energy .

Answer: A



[Watch Video Solution](#)

31. Which of the following kinds of catalysis can be explained by the adsorption theory?

- A. Homogeneous catalysis
- B. Heterogeneous catalysis

C. Negative catalysis

D. Autocatalysis

Answer: B



Watch Video Solution

32. According to the adsorption theory of catalysis the speed of the reaction increases because

A. the heat liberated during adsorption increases the rate of reaction

B. the kinetic energy of reactants increases which increases the rate of reaction

C. the activation energy of reaction increases which increase the rate of reaction

D. The concentration of reactants at the active centres becomes high due to adsorption resulting in increase in the rate of reaction.

Answer: D

 [Watch Video Solution](#)

33. Which oxide of nitrogen is used as a catalyst in lead chamber process for the manufacture of H_2SO_4 ?

A. NO

B. NO_2

C. N_2O_4

D. N_2O_5

Answer: A

 [Watch Video Solution](#)

34. Which of the following is an example of heterogeneous catalysis ?

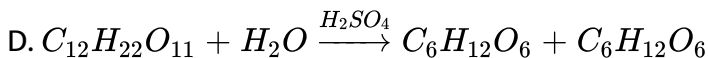
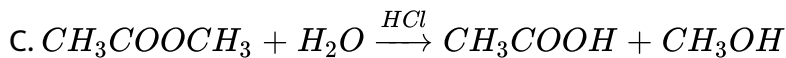
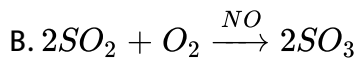
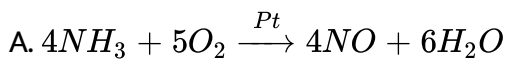

Answer: A

 [Watch Video Solution](#)

35. Shape selective catalysis is a reaction catalysed by

A. zeolites

B. enzymes

C. platinum

D. Ziegler-Natta catalyst.

Answer: A

 [Watch Video Solution](#)

36. Which of the following statements about zeolites is not correct ?

- A. Zeolites are open structures of silica in which trivalent aluminium is substituted by a fraction of silicon atoms.
- B. Shape selectivity of zeolites depends upon porous structure of the catalyst
- C. Zeolites are synthetic microporous aluminosilicates which do not exist naturally.
- D. Zeolites are aluminosilicates having three dimensional network.

Answer: C



[Watch Video Solution](#)

37. The activity of an enzyme becomes ineffective

- A. at low temperature
- B. at atmospheric pressure
- C. at high temperature
- D. in aqueous medium

Answer: C

 [Watch Video Solution](#)

38. Which of the following is not correct for enzyme catalysis?

- A. The enzyme activity is maximum at optimum pH which is between 5-7
- B. Each enzyme is specific for a given reaction.
- C. The favourable temperature range of enzyme activity is between $50 - 60^{\circ}C$.

D. The enzymatic activity is increased in presence of certain substances called co-enzymes.

Answer: C

 [Watch Video Solution](#)

39. Few reactions of industrial importance are listed below. Which of the following catalysts is not correctly matched with the reaction ?

A. Haber's process: Finely divided Fe+Mo as promoter

B. Contact process : V_2O_5

C. Ostwald's process : Fe_2O_3

D. None of these

Answer: C

 [Watch Video Solution](#)

40. Platinised asbestos helps in the formation of SO_3 from SO_2 and O_2 . But, if even a small amount of As_2O_3 is present the platinised asbestos does not help in the formation of SO_3 , As_2O_3 acts here as *a/an*.

- A. catalytic promoter
- B. catalytic poison
- C. dehydrating agent
- D. drying agent .

Answer: B



[View Text Solution](#)

41. Match the column I with Column II and mark the appropriate choice.

Column I		Column II
(A) V_2O_5	(i)	Haber's process
(B) Ni	(ii)	Preparation of O_2 from $KClO_3$
(C) MnO_2	(iii)	Conversion of SO_2 to SO_3
(D) Fe	(iv)	Hydrogenation of oils

A. $(A) \rightarrow (i), (B) \rightarrow (iii), (C) \rightarrow (ii), (D) \rightarrow (iv)$

B. $(A) \rightarrow (ii), (B) \rightarrow (i), (C) \rightarrow (iii), (D) \rightarrow (iv)$

C. $(A) \rightarrow (iii), (B) \rightarrow (iv), (C) \rightarrow (ii), (D) \rightarrow (i)$

D. $(A) \rightarrow (iv), (B) \rightarrow (ii), (C) \rightarrow (i), (D) \rightarrow (iii)$

Answer: C

 [Watch Video Solution](#)

42. The size of colloidal particle is

A. $10^{-7} - 10^{-9}$ cm

B. $10^{-9} \rightarrow 10^{-11}$ cm

C. $10^{-5} \rightarrow 10^{-7}$ cm

D. $10^{-2} \rightarrow 10^{-3}$ cm

Answer: C

 [Watch Video Solution](#)

43. Which of the following will not form a colloidal system ?

A. Solid-gas

B. Liquid-gas

C. Gas-gas

D. Gas-liquid

Answer: C



[Watch Video Solution](#)

44. Fog is a colloidal system of :-

A. liquid in gas

B. gas in liquid

C. solid in gas

D. gas in solid

Answer: A



Watch Video Solution

45. The colloidal system consisting of a liquid dispersed in a solid dispersion medium is termed as :

A. gel

B. sol

C. emulsion

D. aerosol

Answer: A



Watch Video Solution

46. Which of the following examples is correctly matched ?

A. Butter-gel

B. Smoke-emulsion

C. Paint-foam

D. Milk-aerosol

Answer: A



[Watch Video Solution](#)

47. Mark the incorrect combination out of the following examples of colloidal solutions .

- | | | | |
|----|----------|-------------------|-----------------|
| A. | Colloid | Dispersion medium | Dispersed phase |
| | Smoke | Gas | Solid |
| B. | Colloid | Dispersion medium | Dispersed phase |
| | Mist | Gas | Liquid |
| C. | Colloid | Dispersion medium | Dispersed phase |
| | Gel | Liquid | Liquid |
| D. | Colloid | Dispersion medium | Dispersed phase |
| | Emulsion | Liquid | Liquid |

Answer: C

 [Watch Video Solution](#)

48. Lyophilic sols are also called reversible colloids because

- A. they can be reformed by mixing residue (dispersed phase) in dispersion medium even after drying
- B. they can be easily precipitated from the colloidal system
- C. once formed, the dispersion medium and dispersed phase cannot be separated
- D. special reversible reactions are used to prepare them.

Answer: A

 [Watch Video Solution](#)

49. Which of the following is contributed towards the extra stability of lyophilic colloids?

- A. Charge on their particles
- B. Attractive forces between particles
- C. Small size of their particles
- D. high solvation due to a layer of dispersion medium

Answer: D



[Watch Video Solution](#)

50. A lyophobic colloid cannot be formed by

- A. mixing dispersed phase and dispersion medium
- B. chemical reactions like hydrolysis
- C. exchange of solvent
- D. peptisation

Answer: A



Watch Video Solution

51. Which of the following is not the correct difference between lyophobic and lyophilic sols ?

- A. Lyophobic sols Lyophilic sols methods for preparation
Require special Can be prepared by shaking with the solvent
- B. Lyophobic sols Lyophilic sols methods for preparation
Are reversible Are irreversible

C.

Lyophobic sols Lyophilic sols methods for preparation
Easily coagulated by electrolytes Cannot be easily

- D. Lyophobic sols Lyophilic sols methods for preparation
Are less stable Are more stable

Answer: B



Watch Video Solution

52. Which of the following is not correctly matched ?

- A. Gelatin -Lyophilic colloid
- B. Gold sol-Lyophilic colloid
- C. Arsenious sulphide-Lyophobic colloid
- D. Ferric hydroxide-Lyophobic colloid

Answer: B

 [Watch Video Solution](#)

53. Substances which behave as normal electrolytes in solution at low concentration and exhibit colloidal properties at higher concentration are called

- A. lyophilic colloids
- B. lyophobic colloids
- C. macromolecular colloids
- D. associated colloids.

Answer: D

 [Watch Video Solution](#)

54. In these colloids , a large number of small atoms or smaller molecules of a substance aggregate to form colloidal particles having size in colloidal range. These colloids are known as

- A. multimolecular colloids
- B. macromolecular colloids
- C. associated colloids
- D. lyophilic colloids

Answer: A

 [Watch Video Solution](#)

55. The substances which behave as colloidal solutions at higher concentration are called

- A. associated colloids
- B. multimolecular colloids
- C. macromolecular colloids
- D. protective colloids.

Answer: A



[Watch Video Solution](#)

56. The formation of micelles takes place only above

- A. critical temperature
- B. kraft temperature
- C. inversion temperature
- D. absolute temperature

Answer: B

 [Watch Video Solution](#)

57. CMC (Critical Micelle Concentration) is

- A. the concentration at which micellization starts
- B. the concentration at which micelle starts behaving like an electrolyte
- C. the concentration at which dispersed phase is separated from dispersion medium
- D. the concentration at which a colloid is converted to suspension

Answer: A

 [Watch Video Solution](#)

58. At the critical micelle concentration, the surfactant molecules :

A. dissociate

B. associate

C. become bigger in size due to adsorption

D. become smaller in size due to decomposition.

Answer: B

 [Watch Video Solution](#)

59. Soap mixed with water below critical micelle concentration behaves as

A. associated colloids

B. macromolecular colloids

C. normal electrolytic solution

D. multimolecular colloids

Answer: C

 [Watch Video Solution](#)

60. White of an egg whipped with water acts as

- A. macromolecular colloid
- B. associate colloids
- C. molecular colloids
- D. normal electrolytic solution.

Answer: A



[Watch Video Solution](#)

61. Colloidal solutions of metals like gold can be prepared when their salt solutions react with certain substances like $SnCl_2$, formaldehyde, phenylhydrazine, etc.

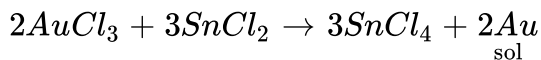

The above method is an example of

A. reduction method

B. oxidation method

C. hydrolysis method

D. double decomposition method

Answer: A

 [Watch Video Solution](#)

62. In Bredig's arc method an electric arc is struck between the metal electrodes under the surface of water containing some stabilizing agent .

The process involves

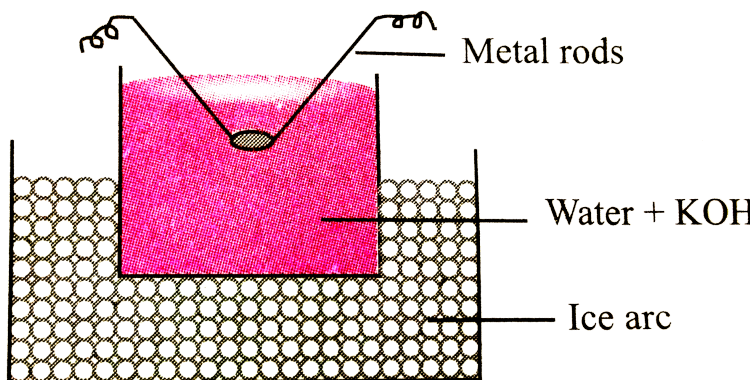

- A. mechanical dispersion
- B. condensation
- C. both dispersion and condensation
- D. ultrasonic dispersion

Answer: C

 [Watch Video Solution](#)

63. When a small quantity of $FeCl_3$ solution is added to the fresh precipitate of $Fe(OH)_3$, a colloidal sol is obtained. The process through which this sol is formed is known as

- A. exchange of solvent
- B. chemical double decomposition
- C. peptization
- D. electrophoresis

Answer: C

 [Watch Video Solution](#)

64. Which of the following is not a method of removing impurities from a colloidal sol ?

- A. Electrodialysis
- B. Ultrafiltration
- C. Ultra centrifugation
- D. Distillation

Answer: D

 [Watch Video Solution](#)

65. Tyndall effect is observed only when

(i) the diameter of the dispersed particles is not much smaller than the

wavelength of the light used.

(ii) the refractive indices of dispersed phase and dispersion medium differ greatly in magnitude .

(iii) the size of the particles is generally between 10^{-11} and 10^{-9} m in diameter.

(iv) the dispersed phase and dispersion medium can be seen separately in the system .

A. (i) and (iii)

B. (i) and (iv)

C. (ii) and (iii)

D. (i) and (ii)

Answer: D



Watch Video Solution

66. Tyndall effect is not observed in

- A. smoke
- B. emulsions
- C. sugar solution
- D. gold sol.

Answer: C

 [Watch Video Solution](#)

67. Which of the following systems will show Tyndall effect ?

- A. Aqueous solution of sodium chloride
- B. Aqueous solution of aluminium hydroxide
- C. Aqueous solution of glucose
- D. Aqueous solution of urea

Answer: B

 [Watch Video Solution](#)

68. The cause of Brownian movement which is not shown by true solutions or suspensions is due to

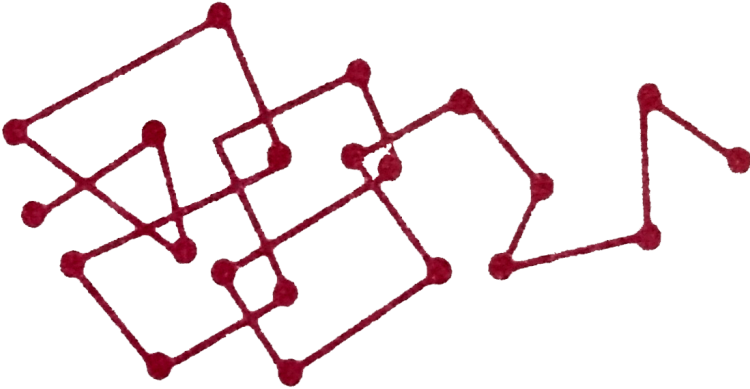

- A. unbalanced bombardment of particles by molecules of the dispersion medium
- B. attractive forces between dispersed phase and dispersion medium
- C. larger size of the particles due to which they keep colliding and settling down
- D. convection currents formed in the sol.

Answer: A



Watch Video Solution

69. Why is ferric hydroxide colloid positively charged when prepared by adding ferric chloride to hot water ?

- A. Due to precipitation of ferric hydroxide there is an excess of Fe^{3+} ions.
- B. Due to preferential adsorption of Fe^{3+} ions by the sol of $Fe(OH)_3$.
- C. Due to absence of any negatively charged ion.
- D. Due to adsorption of OH^- and Cl^- ions, the remaining sol has only Fe^{4+} ions.

Answer: B



Watch Video Solution

70. When an excess of a very dilute aqueous solution of KI is added to a very dilute aqueous solution of silver nitrate, the colloidal particles of silver iodide are associated with which of the following Helmholtz double layer ?

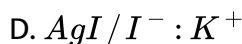
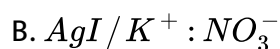
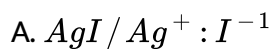

Answer: D



Watch Video Solution

71. The ratio of the number of moles of $AgNO_3$, $Pb(NO_3)_2$ and $Fe(NO_3)_3$ required for coagulation of a definite amount of a colloidal sol of silver iodide prepared by mixing $AgNO_3$ with excess of KI will be

A. 1:2:3

B. 3:2:1

C. 6:3:2

D. 2:3:6

Answer: C



[View Text Solution](#)

72. The combination of two layers of opposite charges around the colloidal particle is called Helmholtz electrical double layer. The potential difference between the fixed layer and the diffused layer of opposite charge is called

A. electrode potential

B. zeta potential

C. adsorption potential

D. diffused potential

Answer: B

 [Watch Video Solution](#)

73. Which of the following is not an explanation for the origin of charge on the colloidal particles ?

- A. Due to frictional electrification
- B. Due to dissociation of surface molecules
- C. Due to electrophoresis
- D. Due to selective adsorption of ions

Answer: C

 [Watch Video Solution](#)

74. Movement of dispersion medium under the influence of electric field is known as

- A. electro dialysis
- B. electrophoresis
- C. Electroosmosis
- D. cataphoresis

Answer: C

 [Watch Video Solution](#)

75. Why is alum added to water containing suspended impurities ?

- A. To make a colloidal solution
- B. To coagulate the suspended impurities
- C. To remove impurities of calcium and magnesium
- D. To protect the colloidal solution from getting precipitated

Answer: B

 [Watch Video Solution](#)

76. Mixing of positively charged colloidal solution with negatively charged colloidal solution brings _____. The decreasing order of coagulating power of Na^+ , Ba^{2+} and Al^{3+} for negatively charged colloidal solution is _____.

A. mutual coagulation, $Na^+ > Ba^{2+} > Al^{3+}$

B. mutual coagulation, $Al^{3+} > Ba^{2+} > Na^+$

C. coagulation, $Na^+ > Ba^{2+} > Al^{3+}$

D. Peptization, $Al^{3+} > Ba^{2+} > Na^+$

Answer: B

 [Watch Video Solution](#)

77. Which one of the following acts as the best coagulating agent for ferric hydroxide sol?

A. Potassium ferrocyanide

B. Potassium chloride

C. Potassium oxalate

D. Aluminium chloride

Answer: A

 [Watch Video Solution](#)

78. Ferric hydroxide sol is more readily conagulated by Na_3PO_4 in comparison to KCl. Why?

A. mass of Na_3PO_4 is more than KCl hence it is more effective than KCl

B. phosphate ion (PO_4^{3-}) has higher negative charge than Cl^- ion hence are more effective for coagulation

C. KCl is more soluble than Na_3PO_4 hence has effective for coagulation

D. Na^+ ions are more effective than K^+ ions for coagulation.

Answer: B

 [Watch Video Solution](#)

79. Which of the following solutions having same concentration will have lowest pH value?

A. KCl

B. $MgCl_2$

C. $AlCl_3$

D. Na_3PO_4

Answer: C

 [View Text Solution](#)

80. Among the electrolytes Na_2SO_4 , $CaCl_2$, $Al_2(SO_4)_3$ and NH_4Cl , the most effective coagulating agent for Sb_2S_3 sol is

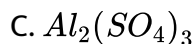
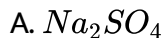

Answer: C



Watch Video Solution

81. When iron hydroxide colloidal sol which is positively charged, and colloidal gold which is negatively charged are mixed, which of the following observations is not correct ?

A. There is no effect of mixing the sols.

B. Mutual coagulation in both can be takes place.

C. Ferric hydroxide is coagulated

D. Gold sol is coagulated

Answer: A

 [View Text Solution](#)

82. Why is gelatin mixed with gold sol ?

A. Gold sol is lyophobic sol, gelatin acts as stabilising agent .

B. Gold sol is lyophilic sol, gelatin acts as stabilising agent .

C. Gelatin produces negative charge on gold particles in gold sol.

D. Gelatin helps gold sol to get its critical micelle concentration.

Answer: A

 [Watch Video Solution](#)

83. Which of the following is not a method for coagulation of lyophobic sols ?

- A. By electrophoresis
- B. By mixing oppositely charged sols
- C. By adding electrolyte
- D. By adding a protective colloid

Answer: D



[Watch Video Solution](#)

84. What happens when lyophilic sol is added to a lyophobic sol?

- A. Lyophilic sol is protected
- B. Lyophobic sol is protected
- C. Both the sols are coagulated
- D. Electrophoresis takes place

Answer: B



Watch Video Solution

85. Which of the following is not a correct match ?

- A. Butter -O/W type emulsion
- B. Vanishing cream -O/W type emulsion
- C. Milk -O/W type emulsion
- D. Cream-W/O type emulsion

Answer: A



Watch Video Solution

86. Which of the following is not an example of an emulsifying agent ?

- A. Proteins

B. Gums

C. Soaps

D. Electrolytes

Answer: D



Watch Video Solution

87. The separation of an emulsion into its constituent liquids is known as

A. emulsification

B. protective of colloid

C. coagulation

D. demulsification

Answer: D



Watch Video Solution

88. Which of the following statements given about emulsions is incorrect ?

A. The droplets in emulsions are often negatively charged and can be precipitated by electrolytes .

B. Emulsion can be diluted with any amount of the dispersed liquid.

On the other hand, the dispersion medium when mixed, forms a separate layer.

C. Emulsions can be broken into constituent liquids by heating , freezing , centrifuging ,etc.

D. Emulsions also show Brownian movement and Tyndall effect.

Answer: B



Watch Video Solution

89. Match the column I with column II respect to applications of properties of colloids in different fields and mark the appropriate choice.

Column I		Column II	
(A)	Coagulation	(i)	Colloidal medicines
(B)	Adsorption	(ii)	Photographic films
(C)	Electrophoresis	(iii)	Sewage disposal
(D)	Emulsions	(iv)	Smoke precipitator

A. (A) \rightarrow (iii), (B) \rightarrow (i), (C) \rightarrow (ii), (D) \rightarrow (iv)

B. (A) \rightarrow (iii), (B) \rightarrow (iii), (C) \rightarrow (i), (D) \rightarrow (iv)

C. (A) \rightarrow (iii), (B) \rightarrow (i), (C) \rightarrow (iv), (D) \rightarrow (ii)

D. (A) \rightarrow (i), (B) \rightarrow (iv), (C) \rightarrow (iii), (D) \rightarrow (ii)

Answer: C



Watch Video Solution

90. Match the column I with Column II and mark the appropriate choice.

Column I		Column II	
(A)	Water loving colloids	(i)	Irreversible
(B)	Liquid dispersed in gas	(ii)	Emulsifying agent
(C)	Hydrophobic sol	(iii)	Hydrophilic
(D)	Soap	(iv)	Aerosol
(E)	Micelles	(v)	Coagulation
(F)	Hardy-Schulze rule	(vi)	Associated colloids

A.

(A) \rightarrow (iii), (B) \rightarrow (iv), (C) \rightarrow (i), (D) \rightarrow (ii), (E) \rightarrow (vi), (F) \rightarrow (v)

B.

(A) \rightarrow (i), (B) \rightarrow (vi), (C) \rightarrow (v), (D) \rightarrow (iii), (E) \rightarrow (iv), (F) \rightarrow (ii)

C.

(A) \rightarrow (vi), (B) \rightarrow (iv), (C) \rightarrow (v), (D) \rightarrow (ii), (E) \rightarrow (iii), (F) \rightarrow (i)

D.

(A) \rightarrow (ii), (B) \rightarrow (iii), (C) \rightarrow (iv), (D) \rightarrow (v), (E) \rightarrow (vi), (F) \rightarrow (i)

Answer: A



Watch Video Solution

91. Fill in the blanks by putting appropriate choices. Blood is a colloidal solution of an (i) substance. The stypic action of (ii) and (iii) solution is due to (iv) of blood forming a clot which stops further bleeding .

- A. (i) albumoid (ii) aluminium (iii) ferrous chloride (iv) peptization
- B. (i) albumoid (ii) alum (iii) ferric chloride (iv) ferric coagulation
- C. (i) electrolytic (ii) alum (iii) ferric chloride (iv) circulation
- D. (i) negatively charged (ii) chrome alum (iii) sodium chloride (iv) coagulation

Answer: B



Watch Video Solution

92. Why are some medicines more effective in the colloidal form ?

- A. the charged colloidal particles present in it
- B. the large surface area and easy assimilation
- C. precipitation of medicine in the blood
- D. the stabilisation of medicine in colloidal form.

Answer: B



[Watch Video Solution](#)

93. Which of the following statements are correct ?

- (i) When an animal hide, which has negatively charged particles , is soaked in tannin, which contains positively charged colloidal particles, mutual coagulation does not take place.
- (ii) Photographic films are prepared by coating an emulsion of the light sensitive silver bromide in gelatin over glass plates or celluloid films.
- (iii) Latex is a colloidal solution of rubber particles which are negatively

charged.

(iv) In Cottrell precipitator , the smoke , before it comes out from the chimney, is led through a chamber containing plates having a charge opposite to that carried by smoke particles. The particles on coming in contact with these plates acquire some charge and do not get precipitated .

A. (i) and (iv) only

B. (ii) and (iii) only

C. (ii), (iii) and (iv) only

D. All of these.

Answer: B



Watch Video Solution

Hots

1. Select the correct statements .

(i) Physical adsorption is weak, multilayer, non-directional and non-specific.

(ii) Chemical adsorption is strong, unilayer, directional and strong

(iii) Chemical adsorption decreases with temperature

(iv) Chemical adsorption is more stronger than physical adsorption

A. (i) and (iii) only

B. (i), (ii) and (iv) only

C. (iii) only

D. All of these.

Answer: B



Watch Video Solution

2. The correct statement(s) pertaining to the adsorption of a gas on a solid surface is(are)

- (i) adsorption is always exothermic
- (ii) physisorption may transform into chemisorption transform into chemisorption at high temperature
- (iii) physisorption increases with increasing temperature but chemisorption decreases with increasing temperature .
- (iv) chemisorption is more exothermic than physisorption , however it is very slow due to higher energy of activation.

- A. (i) and (iv) only
- B. (ii) and (iii) only
- C. (i),(ii) and (iv) only
- D. All of these.

Answer: C



Watch Video Solution

3. Plot of \log against $\log P$ is a straight line inclined at an angle of 45° .
When the pressure is 0.5 atm and Freundlich parameter ,K is 10, the

amount of solute adsorbed per gram of adsorbent will be : ($\log 5=0.6990$)

A. 5 g

B. 3 g

C. 6 g

D. 12 g

Answer: A



[Watch Video Solution](#)

4. Identify the correct statement regarding enzymes

A. Enzymes are specific biological catalysts that possess well defined active sites.

B. Enzymes are normally heterogeneous catalysts that are very specific in their action.

C. Enzymes are specific biological catalysts that cannot be poisoned.

D. Enzymes are specific biological catalysts that can normally function at very high temperature ($T=1000\text{ K}$)

Answer: B

 [Watch Video Solution](#)

5. The dispersed phase in colloidal iron (III) hydroxide and colloidal gold is positively and negatively charged respectively with of the following statement is not correct ?

- A. Magnesium chloride solution coagulates gold sol readily than iron (III) hydroxide sol.
- B. Sodium sulphate solution causes coagulation in both sols.
- C. Mixing of the two sols has no effect.
- D. Coagulation in both sols can be brought about by electrophoresis.

Answer: C



Watch Video Solution

6. Which of the following statement is/are correct regarding stability of sol ?

Lyophilic sols are stabilised due to a layer of solvent around sol particles.

(ii) Lyophobic sols are stabilised due to presence of charge.

(iii) Addition of lyophilic brings in more stability to lyophobic

(iv) Addition of lyophobic brings in more stability to lyophobic.

A. (ii) only

B. (i) and (iv) only

C. (i), (ii) and (iii) only

D. All of these.

Answer: C



Watch Video Solution

7. On adding $AgNO_3$ solution to KI solution, a negatively charged colloidal sol will be formed in which of the following conditions ?

- A. 100 mL of 0.1 M $AgNO_3$ + 100 mL of 0.1 M KI
- B. 100 mL of 0.1 M $AgNO_3$ + 50 mL of 0.2 M KI
- C. 100 mL of 0.2 M $AgNO_3$ + 100 mL of 0.1 M KI
- D. 100 mL of 0.1 M $AgNO_3$ + 100 mL of 0.15 M KI

Answer: D



[Watch Video Solution](#)

Ncert Exemplar Problems

1. Which of the following process does not occur at the interface of phases?

- A. Crystallisation

B. Heterogeneous catalysis

C. homogeneous catalysis

D. Corrosion

Answer: C

 [Watch Video Solution](#)

2. At the equilibrium position in the process of adsorption

A. $\Delta H > 0$

B. $\Delta H = T\Delta S$

C. $\Delta H > T\Delta S$

D. $\Delta > T\Delta S$

Answer: B

 [Watch Video Solution](#)

3. Which of the following interface cannot be obtained?

A. Liquid-Liquid

B. Solid-Liquid

C. Liquid-Gas

D. Gas-Gas

Answer: D



[Watch Video Solution](#)

4. The term 'sorption' stands for

A. absorption

B. adsorption

C. both absorption and adsorption

D. desorption

Answer: C



Watch Video Solution

5. Extent of physisorption of a gas increases with

- A. increase in temperature
- B. decrease in temperature
- C. decrease in surface area of adsorption
- D. decrease in strength of van der Waals forces.

Answer: B



Watch Video Solution

6. Extent of adsorption of adsorbate from solution phase increases with

..... .

- A. increase in amount of adsorbate in solution
- B. decrease in surface area of adsorbent
- C. increase in temperature of solution
- D. decrease in amount of adsorbate in solution.

Answer: A

 [Watch Video Solution](#)

7. Which one of the following is not applicable to the phenomenon of adsorption?

- A. $\Delta H > 0$
- B. $\Delta G > 0$
- C. $\Delta S < 0$
- D. $\Delta H < 0$

Answer: A

 [Watch Video Solution](#)

8. Which of the following is not favourable condition for physical adsorption ?

A. High pressure

B. negative ΔH

C. higher critical temperature of adsorbate

D. high temperature

Answer: D

 [Watch Video Solution](#)

9. Physical adsorption of a gaseous species may change to chemical adsorption with

A. decrease in temperature

- B. increase in temperature
- C. increase in surface area of adsorbent
- D. decrease in surface area of adsorbent

Answer: B

 [Watch Video Solution](#)

10. In physisorption adsorbent does not show specificity for any particular gas because

- A. involved van der Waals forces are universal
- B. gases involved behave like ideal gases
- C. enthalpy of adsorption is low
- D. it is reversible process

Answer: A

 [Watch Video Solution](#)

11. Which of the following is an example of absorption?

- A. Water on silica gel
- B. Water on calcium chloride
- C. Hydrogen on finely divided nickel
- D. Oxygen on metal surface

Answer: B

 [Watch Video Solution](#)

12. On the basis of data below predict which of the following gases shows least adsorption on a definite amount of charcoal ?

Gas	CO_2	SO_2	CH_4	H_2
Critical temp./K	304	630	190	33

A. CO_2

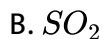

Answer: D



Watch Video Solution

13. In which of the following reactions heterogeneous catalysis is involved?

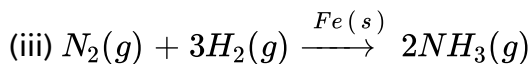
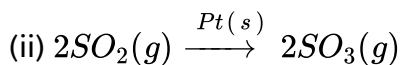
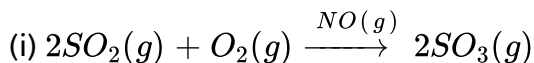

(iv)

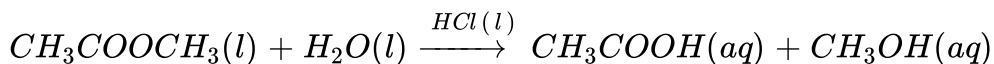

A. (II), (III)

B. (II), (III), (IV)

C. (I), (II), (III)

D. (IV)

Answer: A



[View Text Solution](#)

14. At high concentration of soap in water, soap behaves as

A. molecular colloid

B. associated colloid

C. macromolecular colloid

D. lyophilic colloid

Answer: B



[Watch Video Solution](#)

15. Which of the following will show Tyndall effect?

- A. Aqueous solution of soap below critical micelle concentration
- B. Aqueous solution of soap above critical micelle concentration
- C. Aqueous solution of sodium chloride
- D. Aqueous solution of sugar

Answer: B



[Watch Video Solution](#)

16. Method by which lyophobic sol can be protected

- A. by addition of oppositely charged sol.
- B. by addition of an electrolyte
- C. by addition of lyophilic sol
- D. by boiling

Answer: C

 [Watch Video Solution](#)

17. Freshly prepared precipitate sometimes gets converted to colloidal solution by _____ .

A. coagulation

B. electrolysis

C. diffusion

D. peptisation

Answer: D

 [Watch Video Solution](#)

18. Which of the following electrolytes will have maximum coagulating value for Ag/Ag^+ sol?

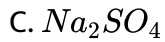
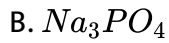
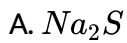

Answer: B



Watch Video Solution

19. A colloidal system having a solid substance as a dispersed phase and a liquid as a dispersion medium is classified as

A. solid sol

B. gel

C. emulsion

D. sol

Answer: D

 [Watch Video Solution](#)

20. The values of colligative properties of colloidal solution are of small order in comparison to those shown by true solutions of same concentration because of colloidal particles

- A. (A) exhibit enormous surface area
- B. (B) remain suspended in the dispersion
- C. (C) form lyophilic colloids
- D. (D) are comparatively less in number

Answer: D

 [Watch Video Solution](#)

21. Arrange the following diagrams in correct sequence of steps involved in the mechanism of catalysis, in accordance with modern adsorption theory.

(i)

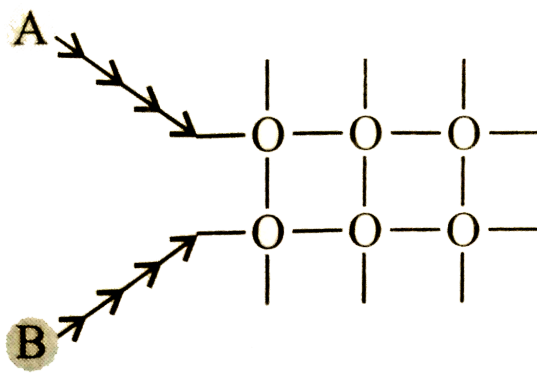

(ii)

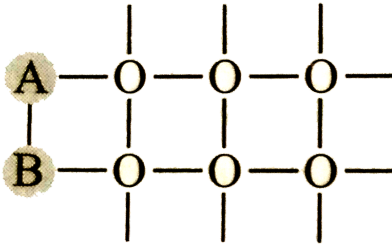

(iii)

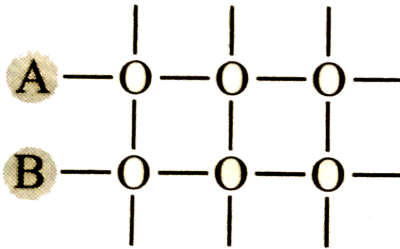

(iv)

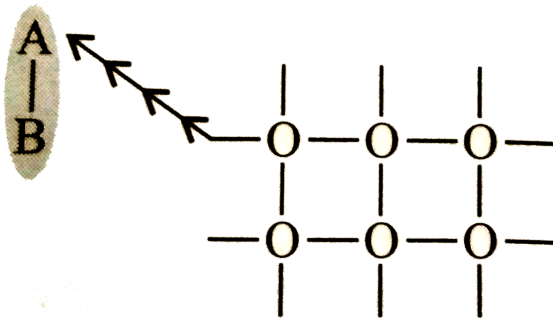



+

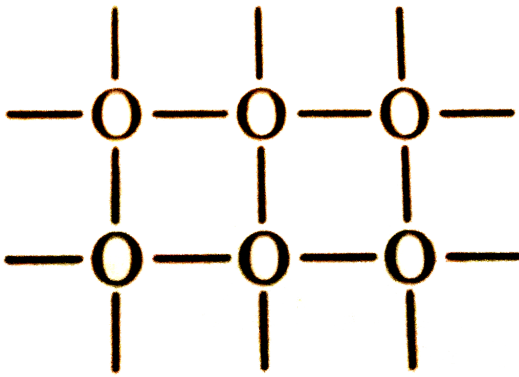

- A. $(i) \rightarrow (ii) \rightarrow (iii) \rightarrow (iv) \rightarrow (v)$
- B. $(i) \rightarrow (iii) \rightarrow (ii) \rightarrow (iv) \rightarrow (v)$
- C. $(i) \rightarrow (iii) \rightarrow (ii) \rightarrow (v) \rightarrow (iv)$
- D. $(i) \rightarrow (ii) \rightarrow (iii) \rightarrow (v) \rightarrow (iv)$

Answer: B

 [Watch Video Solution](#)

22. Which of the following process is responsible for the formation of delta at a place where rivers meet the sea?

A. Emulsification

B. Colloid formation

C. Coagulation

D. peptisation

Answer: C

 Watch Video Solution

23. Which of the following curves is in accordance with Freundlich adsorption isotherm ?

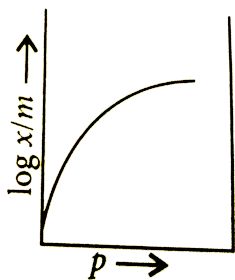

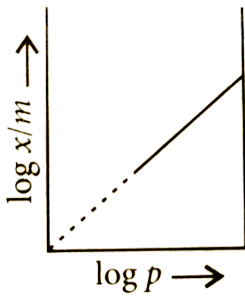
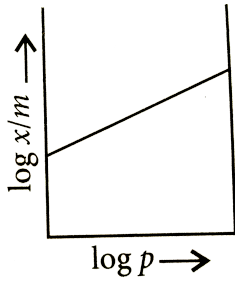
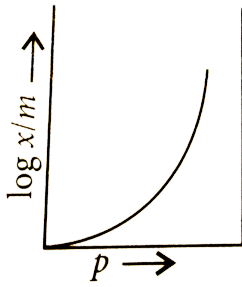

Answer: C



Watch Video Solution

24. Which of the following process is not responsible for the presence of electric charge on the sol particles?

- A. Electron capture by sol particles
- B. Adsorption of ionic species from solution
- C. Formation of Helmholtz electrical double layer
- D. Absorption of ionic species from solution.

Answer: D

 [Watch Video Solution](#)

25. Which of the following phenomenon is applicable to the process shown in the figure ?

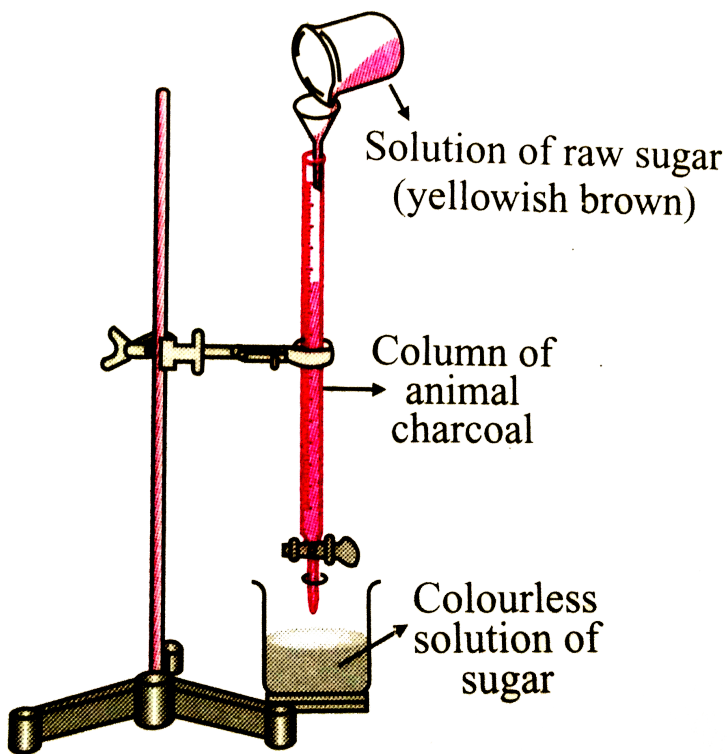

- A. absorption
- B. Adsorption
- C. Coagulation
- D. Emulsification

Answer: B



Watch Video Solution

1. Assertion : Solids in finely divided state act as good adsorbents.

Reason : Adsorption is a surface phenomenon .

- A. If both assertion and reason are true and reason is the correct explanation of assertion.
- B. If both assertion and reason are true but reason is not the correct explanation of assertion
- C. If assertion is true but reason is false
- D. if both assertion and reason are false

Answer: B



[Watch Video Solution](#)

2. Assertion : Silica gel is used to dry air.

Reason : Silica gel absorbs moisture from air.

- A. If both assertion and reason are true and reason is the correct explanation of assertion.
- B. If both assertion and reason are true but reason is not the correct explanation of assertion
- C. If assertion is true but reason is false
- D. if both assertion and reason are false

Answer: C



Watch Video Solution

3. Assertion : In physical adsorption , enthalpy of adsorption is very low.

Reason : In physical adsorption , enthalpy of adsorption is very low.

Reason : In physical adsorption , attraction between gas molecules and solid surface is due to weak van der Waals forces.

- A. If both assertion and reason are true and reason is the correct explanation of assertion.

- B. If both assertion and reason are true but reason is not the correct explanation of assertion
- C. If assertion is true but reason is false
- D. if both assertion and reason are false

Answer: A

 [Watch Video Solution](#)

4. Assertion : Physical adsorption increases with increase in temperature.

Reason : Physical adsorption is an endothermic process.

- A. If both assertion and reason are true and reason is the correct explanation of assertion.
- B. If both assertion and reason are true but reason is not the correct explanation of assertion
- C. If assertion is true but reason is false

D. if both assertion and reason are false

Answer: D

 [Watch Video Solution](#)

5. Assertion : Physisorption of a gas adsorbed at low temperature may change into chemisorption at a high temperature.

Reason : Usually low pressure is also favourable for chemisorption

- A. If both assertion and reason are true and reason is the correct explanation of assertion.
- B. If both assertion and reason are true but reason is not the correct explanation of assertion
- C. If assertion is true but reason is false
- D. if both assertion and reason are false

Answer: C



[Watch Video Solution](#)

6. Assertion : Hydrolysis of ester is an example of auto-catalytic reaction.

Reason : A catalyst speeds up the process without participating in the mechanism.

- A. If both assertion and reason are true and reason is the correct explanation of assertion.
- B. If both assertion and reason are true but reason is not the correct explanation of assertion
- C. If assertion is true but reason is false
- D. if both assertion and reason are false

Answer: C



[Watch Video Solution](#)

7. Assertion : Zeolites are good shape-selective catalyst.

Reason : Zeolotes have honeycomb like structures.

- A. If both assertion and reason are true and reason is the correct explanation of assertion.
- B. If both assertion and reason are true but reason is not the correct explanation of assertion
- C. If assertion is true but reason is false
- D. if both assertion and reason are false

Answer: A



[Watch Video Solution](#)

8. Assertion : Amylase in the presence of sodium choride i.e., Na^+ ions catalytically very active.

Reason : Metal ions such as Na^+ , Mn^{2+} , Co^{2+} , Cu^{2+} , etc. act as activators.

- A. If both assertion and reason are true and reason is the correct explanation of assertion.
- B. If both assertion and reason are true but reason is not the correct explanation of assertion
- C. If assertion is true but reason is false
- D. if both assertion and reason are false

Answer: A



[View Text Solution](#)

9. Assertion : Lyophilic sols are reversible sols.

Reason : Lyophilic sols can be reconstituted by simply remixing the dispersed phase and dispersion medium.

- A. If both assertion and reason are true and reason is the correct explanation of assertion.
- B. If both assertion and reason are true but reason is not the correct explanation of assertion
- C. If assertion is true but reason is false
- D. if both assertion and reason are false

Answer: A



Watch Video Solution

10. Assertion : Colloidal sol scatters light while true solution does not.

Reason : The particles in a colloidal sol move slowly than in a true solution.

- A. If both assertion and reason are true and reason is the correct explanation of assertion.

- B. If both assertion and reason are true but reason is not the correct explanation of assertion
- C. If assertion is true but reason is false
- D. if both assertion and reason are false

Answer: B

 [Watch Video Solution](#)

11. Assertion : The values of colligative properties are of smaller order as compared to values shown by true solutions at same concentrations.

Reason : Colloidal particles show Brownian movement .

- A. If both assertion and reason are true and reason is the correct explanation of assertion.
- B. If both assertion and reason are true but reason is not the correct explanation of assertion
- C. If assertion is true but reason is false

D. if both assertion and reason are false

Answer: B

 [Watch Video Solution](#)

12. Assertion : When KI solution is added to $AgNO_3$ solution, negatively charged sol results .

Reason : Negative charge of sol is due to preferential adsorption of iodide ions from the dispersion medium.

A. If both assertion and reason are true and reason is the correct explanation of assertion.

B. If both assertion and reason are true but reason is not the correct explanation of assertion

C. If assertion is true but reason is false

D. if both assertion and reason are false

Answer: D



Watch Video Solution

13. Assertion : In the coagulation of a negative sol the flocculating power is in the order :

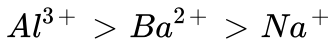

Reason : Greater the valence of the flocculating ion added, greater is its power to cause precipitation.

- A. If both assertion and reason are true and reason is the correct explanation of assertion.
- B. If both assertion and reason are true but reason is not the correct explanation of assertion
- C. If assertion is true but reason is false
- D. if both assertion and reason are false

Answer: A



[Watch Video Solution](#)

14. Assertion : Lyophilic colloids have a unique property of protecting lyophobic colloids.

Reason : Lyophilic colloids are extensively solvated.

- A. If both assertion and reason are true and reason is the correct explanation of assertion.
- B. If both assertion and reason are true but reason is not the correct explanation of assertion
- C. If assertion is true but reason is false
- D. if both assertion and reason are false

Answer: B



[Watch Video Solution](#)

15. Assertion : For stabilisation of an emulsion a third component called emulsifying agent is usually added.

Reason : Emulsions of oil in water are unstable and sometimes they separate into two layers on standing.

A. If both assertion and reason are true and reason is the correct explanation of assertion.

B. If both assertion and reason are true but reason is not the correct explanation of assertion

C. If assertion is true but reason is false

D. if both assertion and reason are false

Answer: B



[Watch Video Solution](#)

Adsorption

1. After the reaction is over between adsorbed reactants, it is important to create space for the other reactant molecules to approach the surface and react. The process responsible for this is known as

- A. sorption
- B. desorption
- C. physisorption
- D. chemisorption

Answer: B



[Watch Video Solution](#)

2. Which of the following statements does not show correct difference between adsorption and absorption ?

- A. In adsorption , the substance is concentrated only at the surface while in absorption it is uniformly distributed in the bulk.

- B. Adsorption is instantaneous while absorption is a slow process.
- C. A substance can be adsorbed as well as absorbed simultaneously and the process is called sorption.
- D. Only gases are adsorbed while solids and liquids are absorbed.

Answer: D

 [Watch Video Solution](#)

3. Why are powdered substance more effective as adsorbents than their crystalline forms ?

- A. adsorption is an exothermic process
- B. they become inert and do not react with the adsorbate
- C. the extent of adsorption increases with increases in surface area of the adsorbent
- D. adsorption is more if the size of adsorbent is small.

Answer: C



Watch Video Solution

4. अधिशोषक के सक्रियण से आप क्या समझते हैं? यह कैसे प्राप्त किया जाता है?

- A. adsorption power is increased by increasing surface area by making the surface rough.
- B. adsorption power is increased by dipping the surface in acid to make it smooth
- C. adsorbing power is increased by dissolving it in water
- D. adsorption power is decreased to reduce the extent of adsorption

Answer: A



Watch Video Solution

5. Fill in the blanks by putting appropriate choices. During adsorption there is _____ in enthalpy and _____ in the entropy of a system by adsorption is a spontaneous process and thus ΔG must be _____. Rate of physisorption _____ with increase in pressure.

A. decrease, decrease, negative , increase

B. increase, increase , positive , decrease

C. decrease, increase, negative , decrease

D. increase, decrease, positive , increase

Answer: A

 [Watch Video Solution](#)

6. Which of the following is less than zero during adsorption?

A. ΔG

B. ΔS

C. ΔH

D. All of these.

Answer: D



Watch Video Solution

7. Physisorption

A. High specificity

B. Irreversibility

C. Non-specificity

D. None of these

Answer: C



Watch Video Solution

8. Which of the following statements is incorrect about physisorption?

- A. It is a reversible process.
- B. It requires less heat of adsorption .
- C. It requires activation energy.
- D. It takes place at low temperature

Answer: C



[Watch Video Solution](#)

9. The incorrect statement about physical adsorption is

- A. it lacks specificity
- B. it is generally reversible
- C. porous surfaces are good adsorbent
- D. heat of adsorption is quite high.

Answer: D

 [Watch Video Solution](#)

10. Which is correct in case of van der Waals adsorption?

- A. High temperature, low pressure
- B. High temperature ,high pressure
- C. Low temperature , low pressure
- D. Low temperature , high pressure

Answer: D

 [Watch Video Solution](#)

11. Adsorption is accompanied by the evolution of heat. Thus, according to Le Chatelier's principle the amount of surface adsorbed should

(i) decrease with increase in temperature

(ii) decrease with decrease in temperature

(iii) increase with increase in temperature

(iv) increase with decrease in temperature

A. increase with decrease in temperature

B. increase with increase in temperature

C. decrease with decrease in temperature

D. be equal at all temperature

Answer: A



Watch Video Solution

12. Which of the following gases is adsorbed most by activated charcoal?

A. HCl

B. NH_3

C. O_2

D. CO_2

Answer: C

 [Watch Video Solution](#)

13. Which of the following is not a characteristic of chemisorption?

A. Adsorption is specific

B. Heat of adsorption is of the order of 200 KJ mol^{-1}

C. Adsorption is irreversible.

D. Adsorption may be multimolecular layers.

Answer: D

 [Watch Video Solution](#)

14. Chemisorption involves formation of bond between gaseous molecules or atoms and the solid surface for which high energy is required. Thus it is also referred as

- A. Chemical adsorption
- B. positive adsorption
- C. activated adsorption
- D. passive adsorption

Answer: C



[Watch Video Solution](#)

15. Which of the following is not correct regarding the adsorption of a gas on the surface of solid ?

- A. 1. On increasing pressure, adsorption keeps on increasing
- B. 2. Enthalpy and entropy changes are negative

C. 3. Chemisorption is more specific than physisorption

D. 4. It is a reversible reaction.

Answer: A

 [Watch Video Solution](#)

16. Which plot is the adsorption isobar for chemisorption?

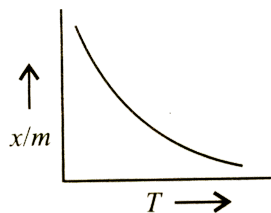
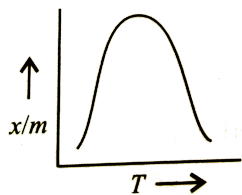
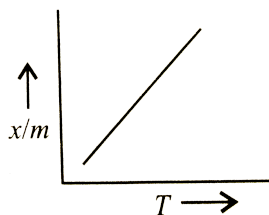

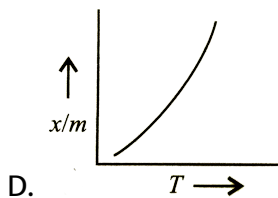

Answer: B

[Watch Video Solution](#)

17. Which of the following statements is not correct for chemisorption and physisorption ?

- A. 1. Physical adsorption occurs at a low temperature and chemisorption occurs at all temperature
- B. 2. Magnitude of chemisorption decreases with rise in temperature while physisorption increases with rise in temperature .
- C. 3. Chemisorption is irreversible and physisorption is reversible .
- D. 4. In physisorption, activation energy is low while in chemisorption, it is high.

Answer: B

 [Watch Video Solution](#)

18. In the adsorption of a gas on solid, Freundlich isotherm is obeyed .

The slope of the plot is zero. Thus, the extent of adsorption is

- A. directly proportional to the pressure of gas
- B. inversely proportional to the pressure of the gas.
- C. independent of the pressure of the gas.
- D. proportional to the square of the pressure of the gas.

Answer: C

 [Watch Video Solution](#)

19. For Freundlich adsorption isotherm, $\frac{x}{m} = kp^1/n$, the value of n is

A. 1. always greater than one

B. 2. always smaller than one

C. 3. always equal to one

D. 4. greater than one at low temperature and smaller than one at high temperature.

Answer: A



[Watch Video Solution](#)

20. Which of the following graph yield a straight line?

A. x/m vs p

B. $\log x/m$ vs p

C. x/m vs $\log p$

D. $\log x/m$ vs $\log p$

Answer: D



[Watch Video Solution](#)

21. At low pressure, the fraction of the surface covered follows.

- A. zero-order kinetics
- B. first order kinetics
- C. second order kinetics
- D. fractional order kinetics

Answer: B



[Watch Video Solution](#)

22. What is the role of activated charcoal in gas mask used in coal mines?

- A. It acts as an adsorbent for poisonous gases
- B. It acts as an adsorbent for coal particles present in coal mines.
- C. It acts as a mask through which exhaled gases and diffused out.

D. It acts as a base for scattering the light.

Answer: A

 [Watch Video Solution](#)

23. Which of the following gases present in a polluted area will be absorbed most easily on the charcoal gas mask ?

A. H_2

B. O_2

C. N_2

D. SO_2

Answer: D

 [Watch Video Solution](#)

24. Match the column I with Column II and mark the appropriate choice.

Column I		Column II	
(A)	Friedel Crafts reaction	(i)	Silica gel
(B)	Humidity control	(ii)	$x/m = kp^{1/n}$
(C)	Gas masks	(iii)	Anhydrous aluminium chloride
(D)	Freundlich adsorption isotherm	(iv)	Adsorb poisonous gas

A. (A) \rightarrow (i), (B) \rightarrow (iii), (C) \rightarrow (ii), (D) \rightarrow (iv)

B. (A) \rightarrow (ii), (B) \rightarrow (iii), (C) \rightarrow (i), (D) \rightarrow (iv)

C. (A) \rightarrow (iii), (B) \rightarrow (i), (C) \rightarrow (iv), (D) \rightarrow (ii)

D. (A) \rightarrow (iv), (B) \rightarrow (i), (C) \rightarrow (iii), (D) \rightarrow (ii)

Answer: C



Watch Video Solution

25. Which of the following is/are application(s) of adsorption?

- A. Adsorption indicators
- B. Thin layer chromatography
- C. Qualitative analysis
- D. All of these.

Answer: D



[Watch Video Solution](#)

26. Why is froth floatation process selected for the concentration of the sulphide ore ?

- A. Shape selective catalysts
- B. Adsorption of pine oil on sulphide ore particles
- C. Adsorption of pine oil on impurities
- D. Production of heat in the process of exothermic reaction.

Answer: B

 [Watch Video Solution](#)

Catalysis

1. Which of the following statements are correct about solid catalyst?

- A. Catalyst is required in equal amount as the reactants present in the reaction.
- B. Catalytic activity of a solid catalyst does not depend upon the extent of chemisorption.
- C. Desorption is not important for a solid to act as good catalyst
- D. Same reactant may give different products by using different catalysts.

Answer: D

 [Watch Video Solution](#)



Watch Video Solution

2. Which can adsorb large volume of hydrogen gas ?

- A. Finely divided platinum
- B. Colloidal solution of palladium
- C. Small pieces of palladium
- D. A single metal surface of platinum

Answer: B



Watch Video Solution

3. Traces of molybdenum are used with finely divided iron which acts as a catalyst during Haber's process for synthesis of ammonia. The Mo

- A. acts as a promoter to increase the activity of the catalyst
- B. acts as a poison to decrease the activity of the catalyst

C. provides a new pathway to the reaction

D. forms another intermediate compound with lesser activation energy .

Answer: A



[Watch Video Solution](#)

4. Which of the following kinds of catalysis can be explained by the adsorption theory?

A. Homogeneous catalysis

B. Heterogeneous catalysis

C. Negative catalysis

D. Autocatalysis

Answer: B



[Watch Video Solution](#)

5. According to the adsorption theory of catalysis the speed of the reaction increases because

- A. the heat liberated during adsorption increases the rate of reaction
- B. the kinetic energy of reactants increases which increases the rate of reaction
- C. the activation energy of reaction increases which increase the rate of reaction
- D. The concentration of reactants at the active centres becomes high due to adsorption resulting in increase in the rate of reaction.

Answer: D



[Watch Video Solution](#)

6. Which oxide of nitrogen is used as a catalyst in lead chamber process for the manufacture of H_2SO_4 ?

A. NO

B. NO_2

C. N_2O_4

D. N_2O_5

Answer: A



Watch Video Solution

7. Which of the following is an example of heterogeneous catalysis ?

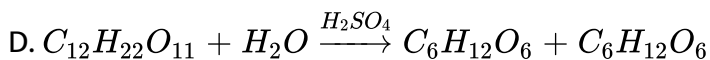
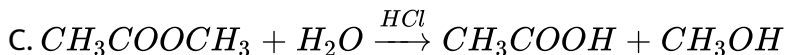
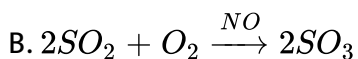
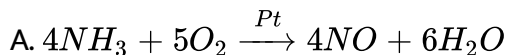

Answer: A



Watch Video Solution

8. Shape selective catalysis is a reaction catalysed by

A. zeolites

B. enzymes

C. platinum

D. Ziegler-Natta catalyst.

Answer: A



Watch Video Solution

9. Which of the following statements about zeolites is not correct ?

- A. Zeolites are open structures of silica in which trivalent aluminium is substituted by a fraction of silicon atoms.
- B. Shape selectivity of zeolites depends upon porous structure of the catalyst
- C. Zeolites are synthetic microporous aluminosilicates which do not exist naturally.
- D. Zeolites are aluminosilicates having three dimensional network.

Answer: C

 [Watch Video Solution](#)

10. Match the column I with Column II and mark the appropriate choice.

Column I		Column II	
(A)	Diastase	(i)	Proteins → peptones
(B)	Pepsin	(ii)	Glucose → ethyl alcohol
(C)	Ptyalin	(iii)	Starch → maltose
(D)	Zymase	(iv)	Starch → sugar

A. $(A) \rightarrow (iv), (B) \rightarrow (ii), (C) \rightarrow (i), (D) \rightarrow (iii)$

B. $(A) \rightarrow (ii), (B) \rightarrow (i), (C) \rightarrow (iv), (D) \rightarrow (iii)$

C. $(A) \rightarrow (i), (B) \rightarrow (ii), (C) \rightarrow (iii), (D) \rightarrow (iv)$

D. $(A) \rightarrow (iii), (B) \rightarrow (i), (C) \rightarrow (iv), (D) \rightarrow (ii)$

Answer: D

 [Watch Video Solution](#)

11. The activity of an enzyme becomes ineffective

A. at low temperature

B. at atmospheric pressure

C. at high temperature

D. in aqueous medium

Answer: C

 [Watch Video Solution](#)

12. Which of the following is not correct for enzyme catalysis?

A. The enzyme activity is maximum at optimum pH which is between 5-

7

B. Each enzyme is specific for a given reaction.

C. The favourable temperature range of enzyme activity is between

$50 - 60^{\circ}C$.

D. The enzymatic activity is increased in presence of certain substances called co-enzymes.

Answer: C



Watch Video Solution

13. Few reactions of industrial importance are listed below. Which of the following catalysts is not correctly matched with the reaction ?

A. Haber's process: Finely divided Fe+Mo as promoter

B. Contact process : V_2O_5

C. Ostwald's process : Fe_2O_3

D. None of these

Answer: C

 [Watch Video Solution](#)

14. Platinised asbestos helps in the formation of SO_3 from SO_2 and O_2 .

But, if even a small amount of As_2O_3 is present the platinised asbestos does not help in the formation of SO_3 , As_2O_3 acts here as *a/an*.

A. catalytic promoter

B. catalytic poison

C. dehydrating agent

D. drying agent .

Answer: B



[View Text Solution](#)

Colloids And Classification Of Colloids

1. The size of colloidal particle is

A. $10^{-7} - 10^{-9}$ cm

B. $10^{-9} \rightarrow 10^{-11}$ cm

C. $10^{-5} \rightarrow 10^{-7}$ cm

D. $10^{-2} \rightarrow 10^{-3}$ cm

Answer: C



[Watch Video Solution](#)

2. Which of the following will not form a colloidal system ?

A. Solid-gas

B. Liquid-gas

C. Gas-gas

D. Gas-liquid

Answer: C

 [Watch Video Solution](#)

3. Fog is a colloidal system of :-

A. liquid in gas

B. gas in liquid

C. solid in gas

D. gas in solid

Answer: A

 [Watch Video Solution](#)

4. The colloidal system consisting of a liquid dispersed in a solid dispersion medium is termed as :

- A. gel
- B. sol
- C. emulsion
- D. aerosol

Answer: A



Watch Video Solution

5. Which of the following examples is correctly matched ?

- A. Butter-gel
- B. Smoke-emulsion
- C. Paint-foam

D. Milk-aerosol

Answer: A

 [Watch Video Solution](#)

6. Mark the incorrect combination out of the following examples of colloidal solutions .

- | | Colloid | Dispersion medium | Dispersed phase |
|----|----------|-------------------|-----------------|
| A. | Smoke | Gas | Solid |
| B. | Mist | Gas | Liquid |
| C. | Gel | Liquid | Liquid |
| D. | Emulsion | Liquid | Liquid |

Answer: C

 [Watch Video Solution](#)

7. Match the column I with Column II and mark the appropriate choice.

Column I		Column II	
(A)	Cheese	(i)	Liquid in gas
(B)	Dust	(ii)	Liquid in solid
(C)	Milk	(iii)	Solid in gas
(D)	Fog	(iv)	Liquid in liquid

A. (A) \rightarrow (iii), (B) \rightarrow (iv), (C) \rightarrow (ii), (D) \rightarrow (i)

B. (A) \rightarrow (iv), (B) \rightarrow (iii), (C) \rightarrow (ii), (D) \rightarrow (i)

C. (A) \rightarrow (i), (B) \rightarrow (ii), (C) \rightarrow (iii), (D) \rightarrow (iv)

D. (A) \rightarrow (ii), (B) \rightarrow (iii), (C) \rightarrow (iv), (D) \rightarrow (i)

Answer: D



Watch Video Solution

8. Lyophilic sols are also called reversible colloids because

- A. they can be reformed by mixing residue (dispersed phase) in dispersion medium even after drying
- B. they can be easily precipitated from the colloidal system
- C. once formed, the dispersion medium and dispersed phase cannot be separated
- D. special reversible reactions are used to prepare them.

Answer: A



Watch Video Solution

9. Which of the following is contributed towards the extra stability of lyophilic colloids?

- A. Charge on their particles
- B. Attractive forces between particles
- C. Small size of their particles

D. high solvation due to a layer of dispersion medium

Answer: D



[Watch Video Solution](#)

10. A lyophobic colloid cannot be formed by

A. mixing dispersed phase and dispersion medium

B. chemical reactions like hydrolysis

C. exchange of solvent

D. peptisation

Answer: A



[Watch Video Solution](#)

11. Which of the following is not the correct difference between lyophobic and lyophilic sols ?

- A. Lyophobic sols Lyophilic sols methods for preparation
Require special Can be prepared by shaking with the solvent
- B. Lyophobic sols Lyophilic sols methods for preparation
Are reversible Are irreversible
- C. Lyophobic sols Lyophilic sols methods for preparation
Easily coagulated by electrolytes Cannot be easily
- D. Lyophobic sols Lyophilic sols methods for preparation
Are less stable Are more stable

Answer: B



[Watch Video Solution](#)

12. Which of the following is not correctly matched ?

- A. Gelatin -Lyophilic colloid
- B. Gold sol-Lyophilic colloid
- C. Arsenious sulphide-Lyophobic colloid

D. Ferric hydroxide-Lyophobic colloid

Answer: B



[Watch Video Solution](#)

13. Substances which behave as normal electrolytes in solution at low concentration and exhibit colloidal properties at higher concentration are called

- A. lyophilic colloids
- B. lyophobic colloids
- C. macromolecular colloids
- D. associated colloids.

Answer: D



[Watch Video Solution](#)

14. In these colloids , a large number of small atoms or smaller molecules of a substance aggregate to form colloidal particles having size in colloidal range. These colloids are known as

- A. multimolecular colloids
- B. macromolecular colloids
- C. associated colloids
- D. lyophilic colloids

Answer: A

 [Watch Video Solution](#)

15. The substances which behave as colloidal solutions at higher concentration are called

- A. associated colloids
- B. multimolecular colloids

C. macromolecular colloids

D. protective colloids.

Answer: A

 [Watch Video Solution](#)

16. The formation of micelles takes place only above

A. critical temperature

B. kraft temperature

C. inversion temperature

D. absolute temperature

Answer: B

 [Watch Video Solution](#)

17. CMC (Critical Micelle Concentration) is

- A. the concentration at which micellization starts
- B. the concentration at which micelle starts behaving like an electrolyte
- C. the concentration at which dispersed phase is separated from dispersion medium
- D. the concentration at which a colloid is converted to suspension

Answer: A



[Watch Video Solution](#)

18. At the critical micelle concentration, the surfactant molecules :

- A. dissociate
- B. associate

C. become bigger in size due to adsorption

D. become smaller in size due to decomposition.

Answer: B



Watch Video Solution

19. In the given figure label the parts

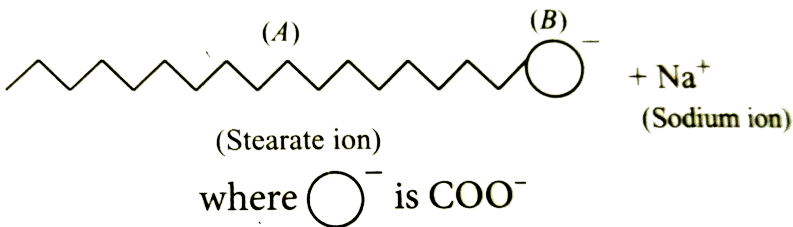

A. A-Hydrophilic tail, B-hydrophobic head

B. A-Hydrophobic tail, B-hydrophobic head

C. A-Hydrophobic tail, B-hydrophilic head

D. A-Hydrophilic tail, B-hydrophilic head

Answer: C

 [Watch Video Solution](#)

20. Soap mixed with water below critical micelle concentration behaves as

- A. associated colloids
- B. macromolecular colloids
- C. normal electrolytic solution
- D. multimolecular colloids

Answer: C

 [Watch Video Solution](#)

21. White of an egg whipped with water acts as

- A. macromolecular colloid
- B. associate colloids
- C. molecular colloids

D. normal electrolytic solution.

Answer: A

 [Watch Video Solution](#)

22. Colloidal solutions of metals like gold can be prepared when their salt solutions react with certain substances like $SnCl_2$, formaldehyde, phenylhydrazine, etc.

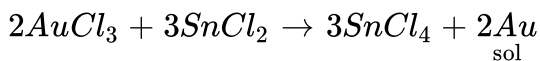

The above method is an example of

- A. reduction method
- B. oxidation method
- C. hydrolysis method
- D. double decomposition method

Answer: A

 [Watch Video Solution](#)

23. When a small quantity of $FeCl_3$ solution is added to the fresh precipitate of $Fe(OH)_3$, a colloidal sol is obtained. The process through which this sol is formed is known as

- A. exchange of solvent
- B. chemical double decomposition
- C. peptization
- D. electrophoresis

Answer: C



Watch Video Solution

24. Which of the processes is being shown in the figure ?

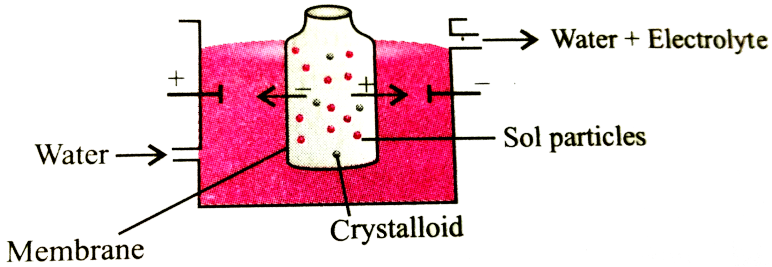

- A. Electrodialysis
- B. Dialysis
- C. Electroosmosis
- D. electrophoresis

Answer: A



[Watch Video Solution](#)

25. Which of the following is not a method of removing impurities from a colloidal sol ?

- A. Electrodialysis
- B. Ultrafiltration
- C. Ultra centrifugation
- D. Distillation

Answer: D

 [Watch Video Solution](#)

26. Tyndall effect is observed only when

- (i) the diameter of the dispersed particles is not much smaller than the wavelength of the light used.
- (ii) the refractive indices of dispersed phase and dispersion medium differ greatly in magnitude .
- (iii) the size of the particles is generally between 10^{-11} and 10^{-9} m in diameter.
- (iv) the dispersed phase and dispersion medium can be seen separately in the system .

A. (i) and (iii)

B. (i) and (iv)

C. (ii) and (iii)

D. (i) and (ii)

Answer: D

[Watch Video Solution](#)

27. When a colloidal solution is viewed from the direction at right angles of light beam, the path of the beam is illuminated due to scattering of light. In the figure (A) and (B) are

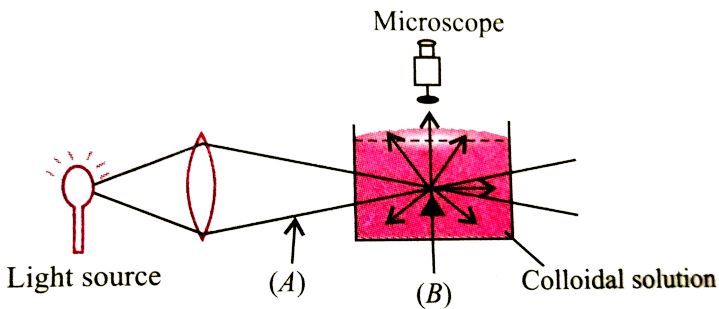

A. A-Tyndall cone, B-Scattered light

B. A-Scattered light, B-Tyndall cone

C. A-Tyndall cone, B-Blind spot

D. A-Tyndall effect, B-Tyndall cone

Answer: A



[Watch Video Solution](#)

28. Tyndall effect is not observed in

A. smoke

B. emulsions

C. sugar solution

D. gold sol.

Answer: C



[Watch Video Solution](#)

29. Which of the following systems will show Tyndall effect ?

- A. Aqueous solution of sodium chloride
- B. Aqueous solution of aluminium hydroxide
- C. Aqueous solution of glucose
- D. Aqueous solution of urea

Answer: B

 [Watch Video Solution](#)

30. Why is ferric hydroxide colloid positively charged when prepared by adding ferric chloride to hot water ?

- A. Due to precipitation of ferric hydroxide there is an excess of Fe^{3+} ions.
- B. Due to preferential adsorption of Fe^{3+} ions by the sol of $Fe(OH)_3$.

C. Due to absence of any negatively charged ion.

D. Due to adsorption of OH^- and Cl^- ions, the remaining sol has only Fe^{4+} ions.

Answer: B

 [Watch Video Solution](#)

31. When an excess of a very dilute aqueous solution of KI is added to a very dilute aqueous solution of silver nitrate, the colloidal particles of silver iodide are associated with which of the following Helmholtz double layer ?

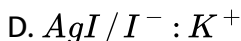
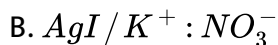
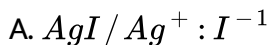

Answer: D

 [Watch Video Solution](#)

32. The ratio of the number of moles of $AgNO_3$, $Pb(NO_3)_2$ and $Fe(NO_3)_3$ required for coagulation of a definite amount of a colloidal sol of silver iodide prepared by mixing $AgNO_3$ with excess of KI will be

A. 1 : 2 : 3

B. 3 : 2 : 1

C. 6 : 3 : 2

D. 2 : 3 : 6

Answer: C

 [View Text Solution](#)

33. The combination of two layers of opposite charges around the colloidal particle is called Helmholtz electrical double layer. The potential difference between the fixed layer and the diffused layer of opposite charge is called

- A. electrode potential
- B. zeta potential
- C. adsorption potential
- D. diffused potential

Answer: B

 [Watch Video Solution](#)

34. Which of the following is not an explanation for the origin of charge on the colloidal particles ?

- A. Due to frictional electrification

- B. Due to dissociation of surface molecules
- C. Due to electrophoresis
- D. Due to selective adsorption of ions

Answer: C

 [Watch Video Solution](#)

35. Movement of dispersion medium under the influence of electric field is known as

- A. electrodialysis
- B. electrophoresis
- C. Electroosmosis
- D. cataphoresis

Answer: C

 [Watch Video Solution](#)

36. Why is alum added to water containing suspended impurities ?

- A. To make a colloidal solution
- B. To coagulate the suspended impurities
- C. To remove impurities of calcium and magnesium
- D. To protect the colloidal solution from getting precipitated

Answer: B



[Watch Video Solution](#)

37. Mixing of positively charged colloidal solution with negatively charged colloidal solution brings _____. The decreasing order of coagulating power of Na^+ , Ba^{2+} and Al^{3+} for negatively charged colloidal solution is _____.

A. mutual coagulation, $Na^+ > Ba^{2+} > Al^{3+}$

B. mutual coagulation , $Al^{3+} > Ba^{2+} > Na^{+}$

C. coagulation , $Na^{+} > Ba^{2+} > Al^{3+}$

D. Peptization , $Al^{3+} > Ba^{2+} > Na^{+}$

Answer: B



[Watch Video Solution](#)

38. Which one of the following acts as the best coagulating agent for ferric hydroxide sol?

A. Potassium ferrocyanide

B. Potassium chloride

C. Potassium oxalate

D. Aluminium chloride

Answer: A



[Watch Video Solution](#)

39. Ferric hydroxide sol is more readily conagulated by Na_3PO_4 in comparison to KCl. Why?

A. mass of Na_3PO_4 is more than KCl hence it is more effective than KCl

B. phosphate ion (PO_4^{3-}) has higher negative charge than Cl^- ion hence are more effective for coagulation

C. KCl is more soluble than Na_3PO_4 hence has effective for coagulation

D. Na^+ ions are more effective than K^+ ions for coagulation.

Answer: B



Watch Video Solution

40. Which of the following solutions having same concentration will have lowest pH value?

A. KCl

B. $MgCl_2$

C. $AlCl_3$

D. Na_3PO_4

Answer: C



[View Text Solution](#)

41. Among the electrolytes Na_2SO_4 , $CaCl_2$, $Al_2(SO_4)_3$ and NH_4Cl , the most effective coagulating agent for Sb_2S_3 sol is

A. Na_2SO_4

B. $CaCl_2$

C. $Al_2(SO_4)_3$

D. NH_4Cl

Answer: C

 [Watch Video Solution](#)

42. When iron hydroxide colloidal sol which is positively charged, and colloidal gold which is negatively charged are mixed, which of the following observations is not correct ?

- A. There is no effect of mixing the sols.
- B. Mutual coagulation in both can be takes place.
- C. Ferric hydroxide is coagulated
- D. Gold sol is coagulated

Answer: A

 [View Text Solution](#)

43. Why is gelatin mixed with gold sol ?

- A. Gold sol is lyophobic sol, gelatin acts as stabilising agent .
- B. Gold sol is lyophilic sol, gelatin acts as stabilising agent .
- C. Gelatin produces negative charge on gold particles in gold sol.
- D. Gelatin helps gold sol to get its critical micelle concentration.

Answer: A



[Watch Video Solution](#)

44. Which of the following is not a method for coagulation of lyophobic sols ?

- A. By electrophoresis
- B. By mixing oppositely charged sols
- C. By adding electrolyte
- D. By adding a protective colloid

Answer: D

 [Watch Video Solution](#)

45. What happens when lyophilic sol is added to a lyophobic sol?

- A. Lyophilic sol is protected
- B. Lyophobic sol is protected
- C. Both the sols are coagulated
- D. Electrophoresis takes place

Answer: B

 [Watch Video Solution](#)

Emulsions

1. Which of the following is not a correct match ?

- A. Butter -O/W type emulsion
- B. Vanishing cream -O/W type emulsion
- C. Milk -O/W type emulsion
- D. Cream-W/O type emulsion

Answer: A

 [Watch Video Solution](#)

2. Which of the following is not an example of an emulsifying agent ?

- A. Proteins
- B. Gums
- C. Soaps
- D. Electrolytes

Answer: D

 [Watch Video Solution](#)

3. The separation of an emulsion into its constituent liquids is known as

- A. emulsification
- B. protective of colloid
- C. coagulation
- D. demulsification

Answer: D



Watch Video Solution

4. Which of the following statements given about emulsions is incorrect ?

- A. The droplets in emulsions are often negatively charged and can be precipitated by electrolytes .

B. Emulsion can be diluted with any amount of the dispersed liquid.

On the other hand, the dispersion medium when mixed, forms a separate layer.

C. Emulsions can be broken into constituent liquids by heating , freezing , centrifuging ,etc.

D. Emulsions also show Browian movement and Tyndall effect.

Answer: B



Watch Video Solution

5. Fill in the blanks by putting appropriate choices. Blood is a colloidal solution of an __ (i) __ substance. The stypic action of __ (ii) __ and __ (iii) __ solution is due to __ (iv) __ of blood forming a clot which stops further bleeding .

A. (i) albumoid (ii) aluminium (iii) ferrous chloride (iv) peptization

B. (i) albumoid (ii) alum (iii) ferric chloride (iv) coagulation

C. (i) electrolytic (ii) alum (iii) ferric chloride (iv) circulation

D.

(i) negatively charged (ii) chrome alum (iii) sodium chloride (iv) coagulation

Answer: B

 [Watch Video Solution](#)

6. Why are some medicines more effective in the colloidal form ?

- A. the charged colloidal particles present in it
- B. the large surface area and easy assimilation
- C. precipitation of medicine in the blood
- D. the stabilisation of medicine in colloidal form.

Answer: B

 [Watch Video Solution](#)

7. Which of the following statements are correct ?

(i) When an animal hide, which has negatively charged particles, is soaked in tannin, which contains positively charged colloidal particles, mutual coagulation does not take place.

(ii) Photographic films are prepared by coating an emulsion of the light sensitive silver bromide in gelatin over glass plates or celluloid films.

(iii) Latex is a colloidal solution of rubber particles which are negatively charged.

(iv) In Cottrell precipitator, the smoke, before it comes out from the chimney, is led through a chamber containing plates having a charge opposite to that carried by smoke particles. The particles on coming in contact with these plates acquire some charge and do not get precipitated.

A. (i) and (iv) only

B. (ii) and (iii) only

C. (ii), (iii) and (iv) only

D. All of these.

Answer: B



Watch Video Solution

Higher Order Thinking Skills

1. Select the correct statements .

(i) Physical adsorption is weak, multilayer, non-directional and non-specific.

(ii) Chemical adsorption is strong, unilayer, directional and strong

(iii) Chemical adsorption decreases with temperature

(iv) Chemical adsorption is more stronger than physical adsorption

A. (i) and (iii) only

B. (i), (ii) and (iv) only

C. (iii) only

D. All of these.

Answer: B



Watch Video Solution

2. The correct statement(s) pertaining to the adsorption of a gas on a solid surface is(are)

(i) adsorption is always exothermic

(ii) physisorption may transform into chemisorption transform into chemisorption at high temperature

(iii) physisorption increases with increasing temperature but chemisorption decreases with increasing temperature .

(iv) chemisorption is more exothermic than physisorption , however it is very slow due to higher energy of activation.

A. (i) and (iv) only

B. (ii) and (iii) only

C. (i),(ii) and (iv) only

D. All of these.

Answer: C



Watch Video Solution

3. Plot of $\log x$ against $\log P$ is a straight line inclined at an angle of 45° . When the pressure is 0.5 atm and Freundlich parameter K is 10, the amount of solute adsorbed per gram of adsorbent will be : ($\log 5 = 0.6990$)

A. 5 g

B. 3 g

C. 6 g

D. 12 g

Answer: A



Watch Video Solution

4. Identify the correct statement regarding enzymes

- A. Enzymes are specific biological catalysts that possess well defined active sites.
- B. Enzymes are normally heterogeneous catalysts that are very specific in their action.
- C. Enzymes are specific biological catalysts that cannot be poisoned.
- D. Enzymes are specific biological catalysts that can normally function at very high temperature ($T=1000\text{ K}$)

Answer: B



[Watch Video Solution](#)

5. The dispersed phase in colloidal iron (III) hydroxide and colloidal gold is positively and negatively charged respectively with of the following statement is not correct ?

- A. Magnesium chloride solution coagulates gold sol readily than iron (III) hydroxide sol.

- B. Sodium sulphate solution causes coagulation in both sols.
- C. Mixing of the two sols has no effect.
- D. Coagulation in both sols can be brought about by electrophoresis.

Answer: C

 [Watch Video Solution](#)

6. Which of the following statement is/are correct regarding stability of sol ?

Lyophilic sols are stabilised due to a layer of solvent around sol particles.

(ii) Lyophobic sols are stabilised due to presence of charge.

(iii) Addition of lyophilic brings in more stability to lyophobic

(iv) Addition of lyophobic brings in more stability to lyophobic.

A. (ii) only

B. (i) and (iv) only

C. (i), (ii) and (iii) only

D. All of these.

Answer: C

 [Watch Video Solution](#)

7. On adding $AgNO_3$ solution to KI solution, a negatively charged colloidal sol will be formed in which of the following conditions ?

A. 100 mL of 0.1 M $AgNO_3$ + 100 mL of 0.1 M KI

B. 100 mL of 0.1 M $AgNO_3$ + 50 mL of 0.2 M KI

C. 100 mL of 0.2 M $AgNO_3$ + 100 mL of 0.1 M KI

D. 100 mL of 0.1 M $AgNO_3$ + 100 mL of 0.15 M KI

Answer: D

 [Watch Video Solution](#)

1. Which of the following process does not occur at the interface of phases?

- A. Crystallisation
- B. Heterogeneous catalysis
- C. homogeneous catalysis
- D. Corrosion

Answer: C



[Watch Video Solution](#)

2. At the equilibrium position in the process of adsorption

- A. $\Delta H > 0$
- B. $\Delta H = T\Delta S$
- C. $\Delta H > T\Delta S$
- D. $\Delta > T\Delta S$

Answer: B



Watch Video Solution

3. Which of the following interface cannot be obtained?

A. Liquid-Liquid

B. Solid-Liquid

C. Liquid-Gas

D. Gas-Gas

Answer: D



Watch Video Solution

4. The term 'sorption' stands for

A. absorption

- B. adsorption
- C. both absorption and adsorption
- D. desorption

Answer: C

 [Watch Video Solution](#)

5. Extent of physisorption of a gas increases with

- A. increase in temperature
- B. decrease in temperature
- C. decrease in surface area of adsorption
- D. decrease in strength of van der Waals forces.

Answer: B

 [Watch Video Solution](#)

6. Extent of adsorption of adsorbate from solution phase increases with

- A. increase in amount of adsorbate in solution
- B. decrease in surface area of adsorbent
- C. increase in temperature of solution
- D. decrease in amount of adsorbate in solution.

Answer: A



[Watch Video Solution](#)

7. Which one of the following is not applicable to the phenomenon of adsorption?

- A. $\Delta H > 0$
- B. $\Delta G > 0$
- C. $\Delta S < 0$

D. $\Delta H < 0$

Answer: A



[Watch Video Solution](#)

8. Which of the following is not favourable condition for physical adsorption ?

A. High pressure

B. negative ΔH

C. higher critical temperature of adsorbate

D. high temperature

Answer: D



[Watch Video Solution](#)

9. Physical adsorption of a gaseous species may change to chemical adsorption with

- A. decrease in temperature
- B. increase in temperature
- C. increase in surface area of adsorbent
- D. decrease in surface area of adsorbent

Answer: B



[Watch Video Solution](#)

10. In physisorption adsorbent does not show specificity for any particular gas because

- A. involved van der Waals forces are universal
- B. gases involved behave like ideal gases
- C. enthalpy of adsorption is low

D. it is reversible process

Answer: A



[Watch Video Solution](#)

11. Which of the following is an example of absorption?

A. Water on silica gel

B. Water on calcium chloride

C. Hydrogen on finely divided nickel

D. Oxygen on metal surface

Answer: B



[Watch Video Solution](#)

12. In which of the following reactions heterogeneous catalysis is involved?

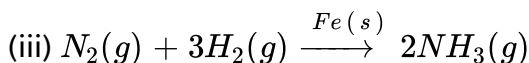
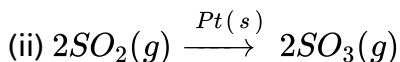
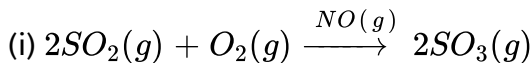

(iv)

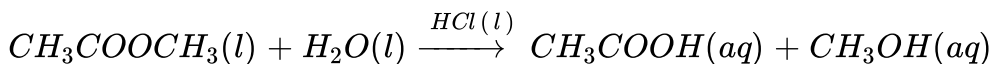

A. (II), (III)

B. (II), (III), (IV)

C. (I), (II), (III)

D. (IV)

Answer: A



[View Text Solution](#)

13. At high concentration of soap in water, soap behaves as

- A. molecular colloid
- B. associated colloid
- C. macromolecular colloid
- D. lyophilic colloid

Answer: B

 [Watch Video Solution](#)

14. Which of the following will show Tyndall effect?

- A. Aqueous solution of soap below critical micelle concentration
- B. Aqueous solution of soap above critical micelle concentration
- C. Aqueous solution of sodium chloride
- D. Aqueous solution of sugar

Answer: B

 [Watch Video Solution](#)

15. Method by which lyophobic sol can be protected

- A. by addition of oppositely charged sol.
- B. by addition of an electrolyte
- C. by addition of lyophilic sol
- D. by boiling

Answer: C



Watch Video Solution

16. Freshly prepared precipitate sometimes gets converted to colloidal solution by _____ .

- A. coagulation
- B. electrolysis
- C. diffusion

D. peptisation

Answer: D



[Watch Video Solution](#)

17. Which of the following electrolytes will have maximum coagulating value for Ag/Ag^+ sol?

A. Na_2S

B. Na_3PO_4

C. Na_2SO_4

D. $NaCl$

Answer: B



[Watch Video Solution](#)

18. A colloidal system having a solid substance as a dispersed phase and a liquid as a dispersion medium is classified as

- A. solid sol
- B. gel
- C. emulsion
- D. sol

Answer: D



[Watch Video Solution](#)

19. The values of colligative properties of colloidal solution are of small order in comparison to those shown by true solutions of same concentration because of colloidal particles

- A. (A) exhibit enormous surface area
- B. (B) remain suspended in the dispersion

C. (C) form lyophilic colloids

D. (D) are comparatively less in number

Answer: D

 [Watch Video Solution](#)

20. Which of the following process is responsible for the formation of delta at a place where rivers meet the sea?

A. Emulsification

B. Colloid formation

C. Coagulation

D. peptisation

Answer: C

 [Watch Video Solution](#)

21. Which of the following curves is in accordance with Freundlich adsorption isotherm ?

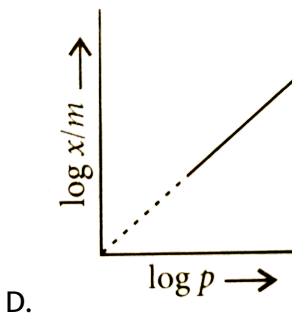
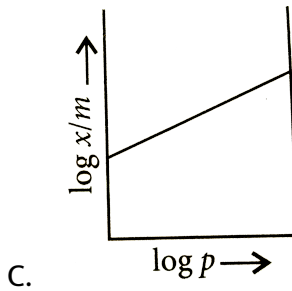
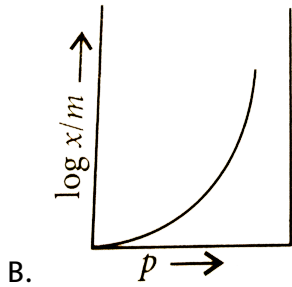
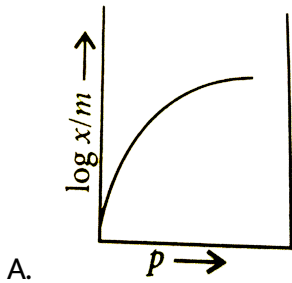

Answer: C

 [Watch Video Solution](#)

22. Which of the following process is not responsible for the presence of electric charge on the sol particles?

- A. Electron capture by sol particles
- B. Adsorption of ionic species from solution
- C. Formation of Helmholtz electrical double layer
- D. Absorption of ionic species from solution.

Answer: D

 [Watch Video Solution](#)

Assertion And Reason

1. Assertion : Solids in finely divided state act as good adsorbents.

Reason : Adsorption is a surface phenomenon .

A. If both assertion and reason are true and reason is the correct explanation of assertion.

B. If both assertion and reason are true but reason is not the correct explanation of assertion

C. If assertion is true but reason is false

D. if both assertion and reason are false

Answer: B



[Watch Video Solution](#)

2. Assertion : Silica gel is used to dry air.

Reason : Silica gel absorbs moisture from air.

- A. If both assertion and reason are true and reason is the correct explanation of assertion.
- B. If both assertion and reason are true but reason is not the correct explanation of assertion
- C. If assertion is true but reason is false
- D. if both assertion and reason are false

Answer: C

 [Watch Video Solution](#)

3. Assertion : In physical adsorption , enthalpy of adsorption is very low.

Reason : In physical adsorption , enthalpy of adsorption is very low.

Reason : In physical adsorption , attraction between gas molecules and solid surface is due to weak van der Waals forces.

- A. If both assertion and reason are true and reason is the correct explanation of assertion.

B. If both assertion and reason are true but reason is not the correct explanation of assertion

C. If assertion is true but reason is false

D. if both assertion and reason are false

Answer: A

 [Watch Video Solution](#)

4. Assertion : Physical adsorption increases with increase in temperature.

Reason : Physical adsorption is an endothermic process.

A. If both assertion and reason are true and reason is the correct explanation of assertion.

B. If both assertion and reason are true but reason is not the correct explanation of assertion

C. If assertion is true but reason is false

D. if both assertion and reason are false

Answer: D

 [Watch Video Solution](#)

5. Assertion : Physisorption of a gas adsorbed at low temperature may change into chemisorption at a high temperature.

Reason : Usually low pressure is also favourable for chemisorption

- A. If both assertion and reason are true and reason is the correct explanation of assertion.
- B. If both assertion and reason are true but reason is not the correct explanation of assertion
- C. If assertion is true but reason is false
- D. if both assertion and reason are false

Answer: C



[Watch Video Solution](#)

6. Assertion : Hydrolysis of ester is an example of auto-catalytic reaction.

Reason : A catalyst speeds up the process without participating in the mechanism.

- A. If both assertion and reason are true and reason is the correct explanation of assertion.
- B. If both assertion and reason are true but reason is not the correct explanation of assertion
- C. If assertion is true but reason is false
- D. if both assertion and reason are false

Answer: C



[Watch Video Solution](#)

7. Assertion : Zeolites are good shape-selective catalyst.

Reason : Zeolotes have honeycomb like structures.

- A. If both assertion and reason are true and reason is the correct explanation of assertion.
- B. If both assertion and reason are true but reason is not the correct explanation of assertion
- C. If assertion is true but reason is false
- D. if both assertion and reason are false

Answer: A



[Watch Video Solution](#)

8. Assertion : Amylase in the presence of sodium choride i.e., Na^+ ions catalytically very active.

Reason : Metal ions such as Na^+ , Mn^{2+} , Co^{2+} , Cu^{2+} , etc. act as activators.

- A. If both assertion and reason are true and reason is the correct explanation of assertion.
- B. If both assertion and reason are true but reason is not the correct explanation of assertion
- C. If assertion is true but reason is false
- D. if both assertion and reason are false

Answer: A



[View Text Solution](#)

9. Assertion : Lyophilic sols are reversible sols.

Reason : Lyophilic sols can be reconstituted by simply remixing the dispersed phase and dispersion medium.

- A. If both assertion and reason are true and reason is the correct explanation of assertion.
- B. If both assertion and reason are true but reason is not the correct explanation of assertion
- C. If assertion is true but reason is false
- D. if both assertion and reason are false

Answer: A



Watch Video Solution

10. Assertion : Colloidal sol scatters light while true solution does not.

Reason : The particles in a colloidal sol move slowly than in a true solution.

- A. If both assertion and reason are true and reason is the correct explanation of assertion.

B. If both assertion and reason are true but reason is not the correct explanation of assertion

C. If assertion is true but reason is false

D. if both assertion and reason are false

Answer: B

 [Watch Video Solution](#)

11. Assertion : The values of colligative properties are of smaller order as compared to values shown by true solutions at same concentrations.

Reason : Colloidal particles show Brownian movement .

A. If both assertion and reason are true and reason is the correct explanation of assertion.

B. If both assertion and reason are true but reason is not the correct explanation of assertion

C. If assertion is true but reason is false

D. if both assertion and reason are false

Answer: B

 [Watch Video Solution](#)

12. Assertion : When KI solution is added to $AgNO_3$ solution, negatively charged sol results .

Reason : Negative charge of sol is due to preferential adsorption of iodide ions from the dispersion medium.

A. If both assertion and reason are true and reason is the correct explanation of assertion.

B. If both assertion and reason are true but reason is not the correct explanation of assertion

C. If assertion is true but reason is false

D. if both assertion and reason are false

Answer: D



Watch Video Solution

13. Assertion : In the coagulation of a negative sol the flocculating power is in the order :

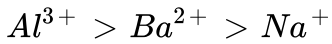

Reason : Greater the valence of the flocculating ion added, greater is its power to cause precipitation.

- A. If both assertion and reason are true and reason is the correct explanation of assertion.
- B. If both assertion and reason are true but reason is not the correct explanation of assertion
- C. If assertion is true but reason is false
- D. if both assertion and reason are false

Answer: A



[Watch Video Solution](#)

14. Assertion : Lyophilic colloids have a unique property of protecting lyophobic colloids.

Reason : Lyophilic colloids are extensively solvated.

- A. If both assertion and reason are true and reason is the correct explanation of assertion.
- B. If both assertion and reason are true but reason is not the correct explanation of assertion
- C. If assertion is true but reason is false
- D. if both assertion and reason are false

Answer: B



[Watch Video Solution](#)

15. Assertion : For stabilisation of an emulsion a third component called emulsifying agent is usually added.

Reason : Emulsions of oil in water are unstable and sometimes they separate into two layers on standing.

A. If both assertion and reason are true and reason is the correct explanation of assertion.

B. If both assertion and reason are true but reason is not the correct explanation of assertion

C. If assertion is true but reason is false

D. if both assertion and reason are false

Answer: B



Watch Video Solution