



PHYSICS

BOOKS - MTG PHYSICS (ENGLISH)

RAY OPTICS AND OPTICAL INSTRUMENTS

Higher Order Thinking

1. A point object O is placed at a distance of 20 cm in front of a equiconvex lens ($\mu_g = 1.5$)

of focal length 10 cm. The lens is placed on a liquid of refractive index 2 as shown in figure. Image will be formed at a distance h from lens the value of h is



- A. 5 cm
- B. 10 cm
- C. 20 cm
- D. 40 cm

Answer: D



2. A ray of light travelling in a medium of refractive index μ is incident at an angle θ on a composite transparent plate consisting of 50 plates of R.I. $1.0\mu, 1.02\mu, 1.03\mu, \dots, 1.50\mu$. The ray emerges from the composite plate into a medium of refractive index 1.6μ at angle ' x '. Then



$$\text{A. } \sin x \left(\frac{1.01}{1.5} \right)^{50} \sin \theta$$

$$\text{B. } \sin x = \frac{5}{8} \sin \theta$$

$$\text{C. } \sin x = \frac{8}{5} \sin \theta$$

$$\text{D. } \sin x = \left(\frac{1.5}{1.01} \right)^{50} \sin \theta$$

Answer: B



Watch Video Solution

3. A linear object of size 1.5cm is placed at 10 cm from a lens of focal length 20 cm . The optic centre of lens and the object are displaced are displaced a distance Δ . The magnification of

the image formed is m . (Take optic centre of origin). The coordinates of image of A and B are (x_1, y_1) and (x_2, y_2) respectively then



A. $(x_1, y_1) = (-20\text{cm}, -2\text{cm})$

B. $(x_2, y_2) = (-20\text{cm}, 2\text{cm})$

C. $m = 5$

D. $m = 4$

Answer: B



Watch Video Solution

4. The size of the image of an object, which is at infinity, as formed by a convex lens of focal length 30 cm is 2 cm. If a concave lens of focal length 20 cm is placed between the convex lens and the image at a distance of 26 cm from the convex lens, calculate the new size of the image.

A. 1.25cm

B. 2.5cm

C. 1.05cm

D. 2cm

Answer: B



Watch Video Solution

5. A bi-convex lens is formed with two thin plano-convex lenses as shown in the figure. Refractive index n of the first lens is 1.5 and that of the second lens is 1.2. Both the curved surfaces are of the same radius of curvature $R = 14\text{cm}$. For this bi-convex lens, for an

object distance of 40cm, the image distance will be

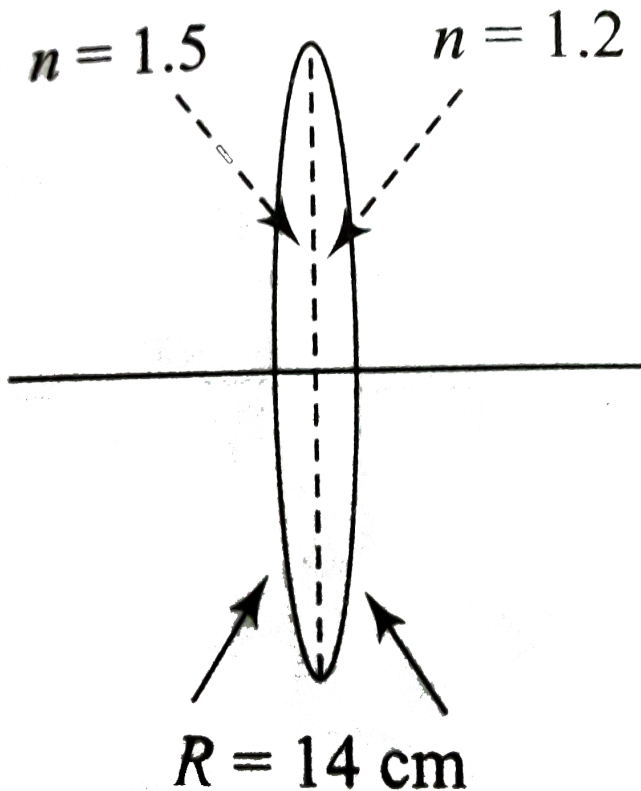

A. -280.0 cm

B. 40.0 cm

C. 21.5cm

D. 13.3cm

Answer: B



Watch Video Solution

6. A ray of light moving along the vector ($-i - 2j$) undergoes refraction at an interface two media, which is the x - z plane. The refractive index for $y > 0$ is 2 and below it is $\sqrt{5}/2$. the

unit vector along which the refracted ray moves is:

A. $\frac{-3\hat{i} - 5\hat{j}}{\sqrt{34}}$

B. $\frac{-(4\hat{i} - 5\hat{j})}{5}$

C. $\frac{-3\hat{i} - 4\hat{j}}{5}$

D. $\frac{-4\hat{i} + 3\hat{j}}{5}$

Answer: D



Watch Video Solution

7. A small bulb (assumed to be a point source) is placed at the bottom of a tank containing water to a depth of 80cm . Find out the area of the surface of water through which light from the bulb can emerge. Take the value of refractive index of water to be $4/3$.

A. 2.6m^2

B. 3.6m^2

C. 4.2m^2

D. 5.8m^2

Answer: A



Watch Video Solution

8. The mixture of a pure liquid and a solution in a long vertical column (i.e., horizontal dimensions \ll vertical dimensions) produces diffusion of solute particles and hence a refractive index gradient along the vertical dimension. A ray of light entering the column at right angles to the vertical is deviated from its original path. Find the

deviation in travelling a horizontal distance

$d < h$, the height of the column.



[View Text Solution](#)

Ncert Exemplar Problems

1. A ray of light incident at an angle θ on a refracting face of a prism emerges from the other face normally. If the angle of the prism is 5° and the prism is made of a material of refractive index 1.5, the angle of incidence is.

A. 7.5°

B. 5°

C. 15°

D. 2.5°

Answer: A



Watch Video Solution

2. A short pulse of white light is incident from air to a glass slab at normal incidence. After

travelling through the slab, the first colour to emerge is.

A. blue

B. green

C. violet

D. red

Answer: D



Watch Video Solution

3. An object approaches a convergent lens from the left of the lens with a uniform speed 5 m/s and stops at the focus. The image.

A. moves away from the lens with an uniform speed 5 m s^{-1}

B. moves away from the lens with an uniform acceleration

C. moves away from the lens with a non-uniform acceleration

D. moves towards the lens with a non - uniform acceleration.

Answer: C



Watch Video Solution

4. A passenger in an aeroplane shall

A. never see a rainbow

B. may see a primary and a secondary rainbow is concentric arcs.

C. may see a primary and a secondary rainbow as concentric arcs.

D. shall never see a secondary rainbow.

Answer: B



Watch Video Solution

5. You are given four sources of light each one providing a light of a single colour-red, blue, green and yellow. Suppose the angle of refraction for a beam of yellow light

corresponding to a particular angle of incidence at the interface of two media is 90° .

Which of the following statements is correct if the source of yellow light is replaced with that of other lights without changing the angle of incidence ?

A. The beam of red light would undergo total internal reflection.

B. The beam of red light would bend toward normal while it gets refracted through the second medium.

C. The beam of blue light would undergo total internal reflection.

D. The beam of green light would bend away from the normal as it gets refracted through the second medium.

Answer: C



Watch Video Solution

6. The radius of curvature of the curved surface of a plano-convex lens is 20cm . If the refractive index of the material of the lens be 1.5, it will

A. act as a convex lens only for the objects that lie on its curved side.

B. act as a concave lens for the objects that lie on its curved side.

C. act as a convex lens irrespective of the side on which the object lies.

D. act as a concave lens irrespective of side on which the object lies.

Answer: C



Watch Video Solution

7. The phenomena involved in the reflected of radiowaves by ionosphere is similar to.

A. reflection of light by a plane mirror.

B. total internal reflection of light in air during a mirage.

C. dispersion of light by water molecules during the formation of a rainbow.

D. scattering of light by particles of air.

Answer: B



Watch Video Solution

8. The direction of ray of light incident on a concave mirror is shown by PQ while directions in which the ray would travel after reflection is shown by four rays marked 1, 2, 3 and 4, Fig. Which of the four rays correctly

shows the direction of reflected ray ?

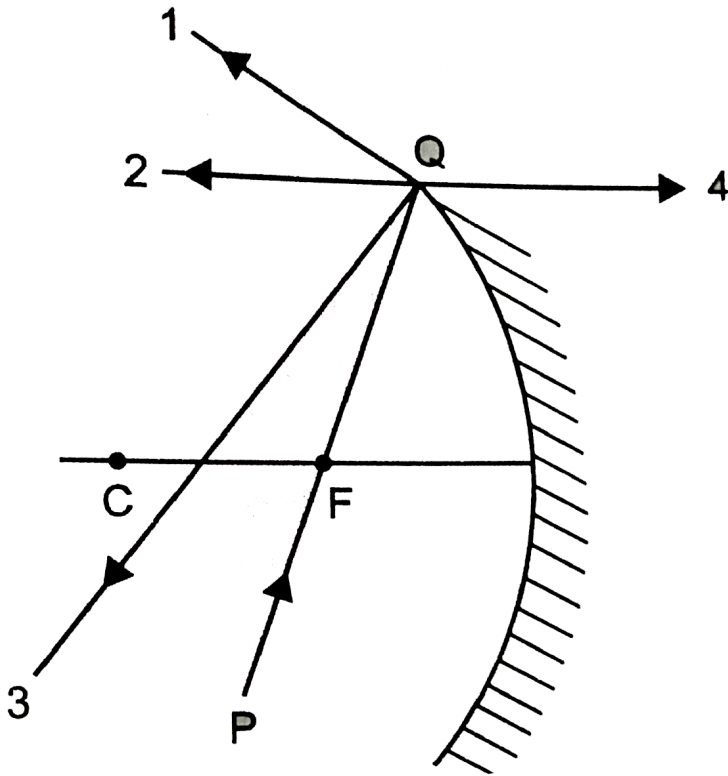

A. 1

B. 2

C. 3

D. 4

Answer: B



Watch Video Solution

9. The optical density of turpentine is higher than that of water, while its mass density is lower. Fig. shows a layer of turpentine floating over water in a container. For which one of the four rays incident on turpentine in Fig., the

path shows is correct ?

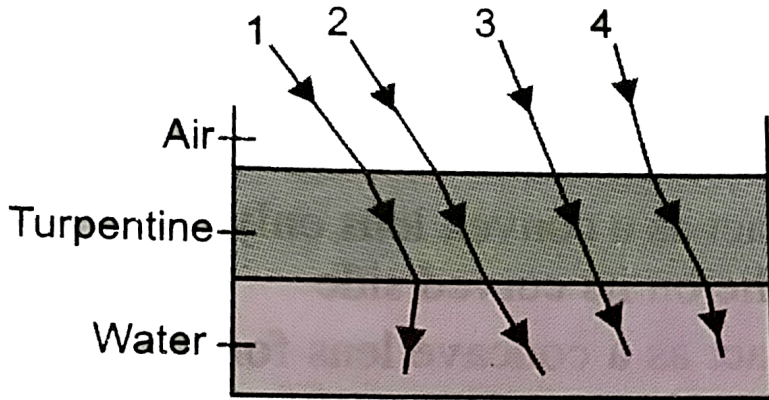

A. 1

B. 2

C. 3

D. 4

Answer: B





10. A car is moving with a constant speed of 60kmh^{-1} on a straight road. Looking at the rear view mirror, the driver finds that the car following him is at a distance of 100m and is approaching with a speed of 5kmh^{-1} . In order to keep track of the car in the rear, the driver begins to glance alternatively at the rear and side mirror of his car after every 2s till the other car overtakes. If the two cars were

maintaining their speeds, which of the following statement (s) is/are correct ?

A. The speed of the car in the rear is

$$65\text{kmh}^{-1}.$$

B. In the side mirror the car in the rear

would appear to approach with a speed

of 5kmh^{-1} to the driver of the leading

car.

C. In the rear view mirror the speed of the

approaching car would appear to

decrease as the distance between the cars decreases.

D. In the side mirror, the speed of the approaching car would appear to increase as the distance between the cars decreases.

Answer: D



Watch Video Solution

11. There are certain materials developed in laboratories which have a negative refractive index, Fig. A ray incident from air (medium 1) into such a medium (medium 2) shall follow a path given by

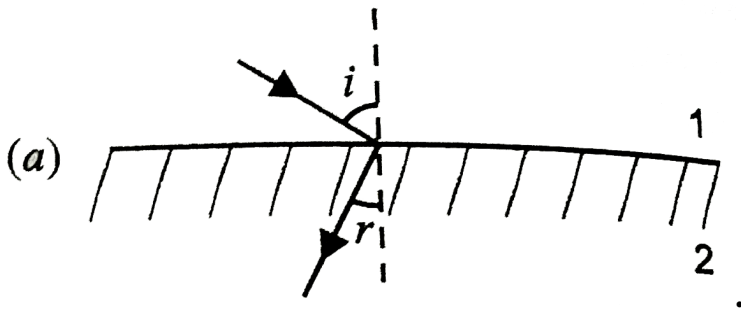

A. 

B. 

C. 

D. 

Answer: A



Watch Video Solution

Assertion And Reason

1. Assertion : A convex mirror is preferred over a plane mirror in vehicles to observe traffic coming from behind.

Reason : Images formed by convex mirrors are erect and diminished in size.

A. If both assertion and reason are true and reason is the correct explanation of assertion.

B. If both assertion and reason are true and reason is not the correct explanation of assertion.

C. If assertion is true but reason is false.

D. If both assertion and reason are false.

Answer: A



Watch Video Solution

2. Assertion : The size of the mirror affect the nature of the image.

Reason : Small mirrorrs always forms a virtual image.

A. If both assertion and reason are true and reason is the correct explanation of assertion.

B. If both assertion and reason are true and reason is not the correct explanation of assertion.

C. If assertion is true but reason is false.

D. If both assertion and reason are false.

Answer: D



Watch Video Solution

3. Assertion : All the materials always have the same colour, whether viewed by reflected light or through transmitted light.

Reason : The colour of material does not depend on nature of light .

A. If both assertion and reason are true and reason is the correct explanation of assertion.

B. If both assertion and reason are true and reason is not the correct

explanation of assertion.

C. If assertion is true but reason is false.

D. If both assertion and reason are false.

Answer: D



Watch Video Solution

4. Assertion : The radius of curvature of a mirror is double of the focal length.

Reason : A concave mirror of focal length f in air is used in a medium of refractive index 2.

Then the focal length of mirror in medium becomes $2f$.

A. If both assertion and reason are true and reason is the correct explanation of assertion.

B. If both assertion and reason are true and reason is not the correct explanation of assertion.

C. If assertion is true but reason is false.

D. If both assertion and reason are false.

Answer: C



Watch Video Solution

5. Assertion : The images formed by total internal reflections are much brighter than those formed by mirrors or lenses.

Reason : There is no loss of intensity in total internal reflection.

A. If both assertion and reason are true and reason is the correct explanation of

assertion.

B. If both assertion and reason are true and reason is not the correct explanation of assertion.

C. If assertion is true but reason is false.

D. If both assertion and reason are false.

Answer: A



Watch Video Solution

6. Assertion : Optical fibres make use of total internal reflection.

Reason : Light undergoes successive total internal reflections as it moves through an optical fibre.

A. If both assertion and reason are true and reason is the correct explanation of assertion.

B. If both assertion and reason are true and reason is not the correct

explanation of assertion.

C. If assertion is true but reason is false.

D. If both assertion and reason are false.

Answer: B



Watch Video Solution

7. Assertion : Diamond are known for their spectacular brilliance, but diamonds found in nature rarely exhibit the brilliance.

Reason : By cutting the diamond suitably,

multiple total internal reflections can be made to occur.

A. If both assertion and reason are true and reason is the correct explanation of assertion.

B. If both assertion and reason are true and reason is not the correct explanation of assertion.

C. If assertion is true but reason is false.

D. If both assertion and reason are false.

Answer: A



Watch Video Solution

8. Assertion : A convex lens of glass ($\mu = 1.5$) behave as a diverging lens when immersed in carbon disulphide of higher refractive index ($\mu = 1.65$).

Reason : A diverging lens is thinner in the middle and thicker at the edges.

A. If both assertion and reason are true and reason is the correct explanation of assertion.

B. If both assertion and reason are true and reason is not the correct explanation of assertion.

C. If assertion is true but reason is false.

D. If both assertion and reason are false.

Answer: B



Watch Video Solution

9. Assertion : Combination of lenses helps to obtain diverging or converging lenses of desired magnification.

Reason : It enhances sharpness of the image.

A. If both assertion and reason are true and reason is the correct explanation of assertion.

B. If both assertion and reason are true and reason is not the correct

explanation of assertion.

C. If assertion is true but reason is false.

D. If both assertion and reason are false.

Answer: B



Watch Video Solution

10. Assertion : Angle of deviation depends on the angle of prism.

Reason : For thin prism, $\delta = (\mu - 1) - A$.

A. If both assertion and reason are true and reason is the correct explanation of assertion.

B. If both assertion and reason are true and reason is not the correct explanation of assertion.

C. If assertion is true but reason is false.

D. If both assertion and reason are false.

Answer: A



Watch Video Solution

11. Assertion : A beam of the white light shows no dispersion on emerging from a glass slab.

Reason : Dispersion in a glass slab is zero.

A. If both assertion and reason are true and reason is the correct explanation of assertion.

B. If both assertion and reason are true and reason is not the correct explanation of assertion.

C. If assertion is true but reason is false.

D. If both assertion and reason are false.

Answer: C



Watch Video Solution

12. Assertion : Bluish colour predominates in a clear sky, since blue has a shorter wavelength and is scattered strongly.

Reason : Blue has the shortest wavelength among all colours.

A. If both assertion and reason are true and reason is the correct explanation of assertion.

B. If both assertion and reason are true and reason is not the correct explanation of assertion.

C. If assertion is true but reason is false.

D. If both assertion and reason are false.

Answer: C



Watch Video Solution

13. Assertion : The rainbow is an example of the dispersion of sunlight by the water drops in the atmosphere.

Reason : No reflection or refraction of light is involved in the formation of rainbow.

A. If both assertion and reason are true and reason is the correct explanation of assertion.

B. If both assertion and reason are true and reason is not the correct explanation of assertion.

C. If assertion is true but reason is false.

D. If both assertion and reason are false.

Answer: C



Watch Video Solution

14. Assertion : Sun looks reddish at sunrise and sunset.

Reason : Sun rays have to pass through large distance in atmosphere.

A. If both assertion and reason are true and reason is the correct explanation of assertion.

B. If both assertion and reason are true and reason is not the correct explanation of assertion.

C. If assertion is true but reason is false.

D. If both assertion and reason are false.

Answer: A



Watch Video Solution

15. Assertion : The focal length of an equiconvex lens placed in air is equal to radius of curvature of either face.

Reason : For an equiconvex lens radius of curvature of both the faces is same.

A. If both assertion and reason are true and reason is the correct explanation of assertion.

B. If both assertion and reason are true and reason is not the correct explanation of assertion.

C. If assertion is true but reason is false.

D. If both assertion and reason are false.

Answer: B



Watch Video Solution

Multiple Choice Questions

1. What can be the largest distance of an image of real object from a convex mirror of radius of curvature is 20cm ?

A. 10cm

B. 20cm

C. Infinity

D. Zero

Answer:



Watch Video Solution

2. A boy of height 1m stands in front of a convex mirror. His distance from the mirror is equal to its focal length. The height of his image is

A. $0.25m$

B. $0.33m$

C. $0.5m$

D. $0.67m$

Answer: C



Watch Video Solution

3. A concave shaving mirror has a radius of curvature of $35.0cm$. It is positioned so that the (upright) image of man's face is 2.50 times the size of the face. How far is the mirror from the face ?

A. $5.25cm$

B. 21.0cm

C. 10.5cm

D. 42cm

Answer: C



Watch Video Solution

4. A rod of length 10 cm lies along the principal axis of a concave mirror of focal length 10 cm in such a way that the end closer

to the pole is 20 cm away from it. Find the length of the image.

A. 10cm

B. 15cm

C. 2.5cm

D. 5cm

Answer: D



Watch Video Solution

5. An object 2cm high is placed at a distance of 16cm from a concave mirror, which produces a real image 3cm high. What is the focal length of the mirror? Find the position of the image?

A. -9.6cm

B. -3.6cm

C. -6.3cm

D. -8.3cm

Answer: A



Watch Video Solution

6. When an object is kept at a distance of 30cm from a concave mirror, the image is formed at a distance of 10 cm. If the object is moved with a speed of $9ms^{-1}$ the speed with which the image moves is

A. $10ms^{-1}$

B. $1ms^{-1}$

C. $9ms^{-1}$

D. $0.9ms^{-1}$

Answer: B



Watch Video Solution

7. A microscope is focused on a mark on a piece of paper and then a slab of glass of thickness $3cm$ and refractive index 1.5 is placed over the mark. How should the microscope be moved to get the mark in focus again ?

A. 4.5cm downward

B. 1cm downward

C. 2cm downward

D. 1cm upward

Answer: D



Watch Video Solution

8. Refraction of light from air to glass and from air to water are shown in figure (i) and figure (ii) below. The value of the angle θ in the case

of refraction as shown in figure (iii) will be

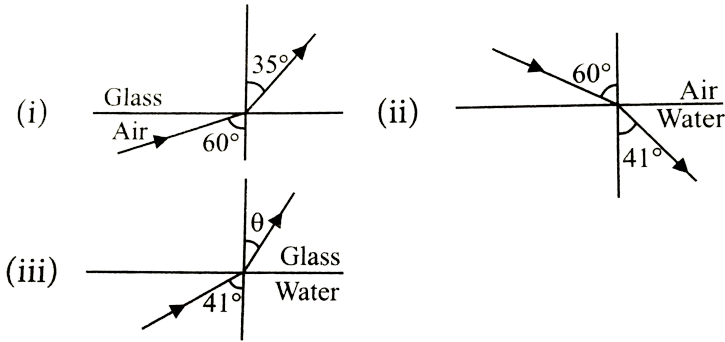

A. 30°

B. 35°

C. 60°

D. 41°

Answer: B



Watch Video Solution

9. A ray of light strikes a transparent rectangular slab of refractive index $\sqrt{2}$ at an angle of incidence of 45° . The angle between the reflected and refracted rays is

A. 75°

B. 90°

C. 105°

D. 120°

Answer: C



Watch Video Solution

10. A rays of light is incident on a thick slab of glass of thickness t as shown in figure. The emergent ray is parallel to the incident ray but displaced sideways by a distance d . If the

angles are small then d is

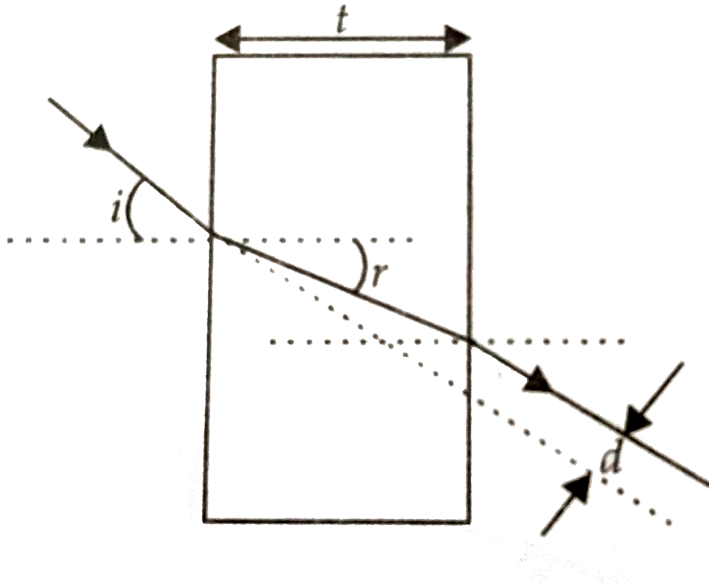

A. $t \left(1 + \frac{i}{r} \right)$

B. $rt \left(1 - \frac{i}{r} \right)$

C. $it \left(1 - \frac{r}{i} \right)$

D. $t \left(1 + \frac{r}{i} \right)$

Answer: C



Watch Video Solution

11. A ray incident at a point at an angle of incidence of 60° enters a glass sphere with refractive index $\sqrt{3}$ and it is reflected and refracted at the farther surface of the sphere. The angle between the reflected and refracted rays at this surface is:

A. 50°

B. 60°

C. 90°

D. 40°

Answer: C



Watch Video Solution

12. The apparent depth of a needle laying at the bottom of the tank, which is filled with water of refractive index 1.33 to a height of 12.5 cm is measured by a microscope to be

9.4cm. If water is replaced by a liquid of refractive index 1.63 upto the same height. What distance would the microscope have to be moved to focus on the needle again ?

A. 1.73cm

B. 2.13cm

C. 1.5cm

D. 2.9cm

Answer: A



Watch Video Solution

13. A point luminous object (O) is at a distance h from front face of a glass slab of width d and of refractive index μ . On the back face of slab is a reflecting plane mirror. An observer sees the image of object in mirror as shown in figure. Distance of image from front face as

seen by observer will be

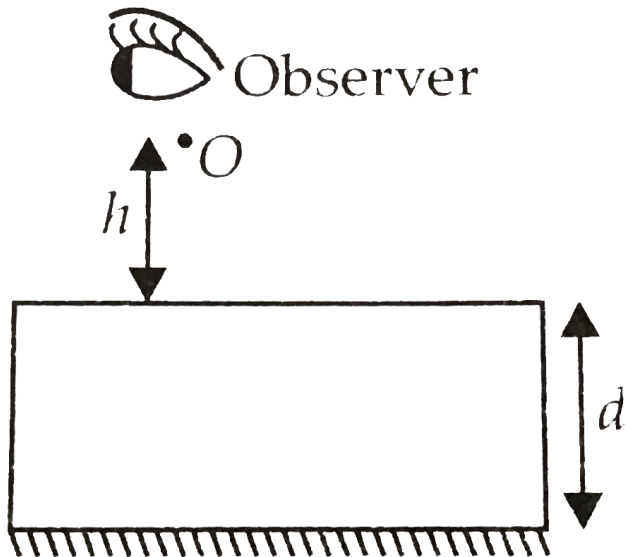

A. $h + \frac{2d}{\mu}$

B. $2h + 2d$

C. $h + d$

D. $h + \frac{d}{\mu}$

Answer: A



Watch Video Solution

14. A vessel of depth x is half filled with oil of refractive index μ_1 and the other half is filled with water of refractive index μ_2 . The apparent depth of the vessel when viewed above is

A. $\frac{x(\mu_1 + \mu_2)}{2\mu_1\mu_2}$

B. $\frac{x\mu_1\mu_2}{2(\mu_1 + \mu_2)}$

C. $\frac{x\mu_1\mu_2}{(\mu_1 + \mu_2)}$

D.
$$\frac{2x(\mu_1 + \mu_2)}{\mu_1\mu_2}$$

Answer: A



Watch Video Solution

15. Three immiscible liquids of densities $d_1 > d_2 > d_3$ and refractive indices $\mu_1 > \mu_2 > \mu_3$ are put in a beaker. The height of each liquid column is $\frac{h}{3}$. A dot is made at the bottom of the beaker. For near normal vision, find the apparent depth of the dot.

A. $\frac{h}{6} \left(\frac{1}{\mu_1} + \frac{1}{\mu_2} + \frac{1}{\mu_3} \right)$

B. $\frac{h}{6} \left(\frac{1}{\mu_1} - \frac{1}{\mu_2} - \frac{1}{\mu_3} \right)$

C. $\frac{h}{3} \left(\frac{1}{\mu_1} - \frac{1}{\mu_2} - \frac{1}{\mu_3} \right)$

D. $\frac{h}{3} \left(\frac{1}{\mu_1} + \frac{1}{\mu_2} + \frac{1}{\mu_3} \right)$

Answer: D



Watch Video Solution

16. A tank is filled with water to a height of 15.5cm . The apparent depth of a needle lying at the bottom of the tank is measured by a

microscope to be 8.5cm . If water is replaced by a liquid of refractive index 1.94 upto the same height by what distance would the microscope have to be moved to focus on the needle again ?

A. 1.00cm

B. 2.37cm

C. 0.51cm

D. 3.93cm

Answer: C



17. For a total internal reflection, which of the following is correct ?

A. Light travel from rarer to denser medium.

B. Light travel from denser to rarer medium.

C. Light travels in air only.

D. Light travels in water only.

Answer: B



Watch Video Solution

18. Light travels in two media A and B with speeds $1.8 \times 10^8 \text{ms}^{-1}$ and $2.4 \times 10^8 \text{ms}^{-1}$ respectively. Then the critical angle between them is

A. $\sin^{-1}\left(\frac{2}{3}\right)$

B. $\tan^{-1}\left(\frac{3}{4}\right)$

C. $\tan^{-1}\left(\frac{2}{3}\right)$

$$D. \sin^{-1}\left(\frac{3}{4}\right)$$

Answer: D



Watch Video Solution

19. Critical angle of glass is θ_1 and that of water is θ_2 . The critical angle for water and glass surface would be

$$(\mu_g = 3/2, \mu_w = 4/3)$$

A. less than θ_2

B. between θ_1 and θ_2

C. greater than θ_2

D. less than θ_1

Answer: C



Watch Video Solution

20. Critical angle for light going from medium (i) to (ii) is θ . The speed of light in medium (i) is v then speed in medium (ii) is

A. $v(1 - \cos \theta)$

B. $\frac{v}{\sin \theta}$

C. $\frac{v}{\cos \theta}$

D. $\frac{v}{(1 - \sin \theta)}$

Answer: B



Watch Video Solution

21. A ray of light travelling in a transparent medium of refractive index μ , falls on a surface separating the medium from air at an angle of

incidence of 45° . For which of the following value of μ the ray can undergo total internal reflection ?

A. $\mu = 1.33$

B. $\mu = 1.40$

C. $\mu = 1.50$

D. $\mu = 1.25$

Answer: C



Watch Video Solution

22. A point source of light is placed at a depth of h below the surface of water of refractive index μ . A floating opaque disc is placed on the surface of water so that light from the source is not visible from the surface. The minimum diameter of the disc is

A. $\frac{2h}{(\mu^2 - 1)^{1/2}}$

B. $2h(\mu^2 - 1)^{1/2}$

C. $\frac{h}{2(\mu^2 - 1)^{1/2}}$

D. $h(\mu^2 - 1)^{1/2}$

Answer: A



Watch Video Solution

23. Mirage' is a phenomenon due to

- A. refraction of light
- B. reflection of light
- C. total internal reflection of light
- D. diffraction of light.

Answer: C



Watch Video Solution

24. From a point source a light falls on a spherical glass surface ($\mu = 1.5$ and radius of curvature = 10cm). The distance between point source and glass surface is 50cm . The position of image is

A. 25cm

B. 50cm

C. 100cm

D. 150cm

Answer: B



Watch Video Solution

25. An air bubble in a glass sphere ($\mu = 1.5$) is situated at a distance 3cm from a convex surface of diameter 10cm . At what distance from the surface will the bubble appear ?

A. 2.5cm

B. -2.5cm

C. 5cm

D. -5cm

Answer: B



Watch Video Solution

26. A convex refracting surface of radius of curvature 20cm separates two media of refractive indices $4/3$ and 1.60 . An object is placed in the first medium ($\mu = 4/3$) at a

distance of 200cm from the refracting surface.

Calculate the position of image formed.

A. 120cm

B. 240cm

C. 100cm

D. 60cm

Answer: B



Watch Video Solution

27. Light from a point source in air falls on a spherical glass surface. If $\mu = 1.5$, and radius of curvature = 20cm , the distance of light source from the glass surface is 100cm , at what position will the image be formed ?
(NCERT Solved Example)

A. 25cm

B. 50cm

C. 100cm

D. 200cm

Answer: C



Watch Video Solution

28. A mark placed on the surface of a sphere is viewed through glass from a position directly opposite. If the diameter of the sphere is 10cm and refractive index of glass is 1.5 , find the position of the image.

A. -20cm

B. 30cm

C. 40cm

D. -10cm

Answer: A



Watch Video Solution

29. A biconvex lens has focal length $\frac{2}{3}$ times the radius of curvature of either surface. Calculate refraction index of material of the lens.

A. 1.75

B. 1.33

C. 1.5

D. 1.0

Answer: A



Watch Video Solution

30. A convex lens of focal length $0.2m$ and made of glass ($\mu = 1.50$) is immersed in

water ($\mu = 1.33$). Find the change in the focal length of the lens.

A. $5.8m$

B. $0.58cm$

C. $0.58m$

D. $5.8cm$

Answer: C



Watch Video Solution

31. A double convex lens, lens made of a material of refractive index μ_1 , is placed inside two liquids or refractive indices μ_2 and μ_3 , as shown. $\mu_2 > \mu_1 > \mu_3$. A wide, parallel beam of light is incident on the lens from the left. The lens will give rise to

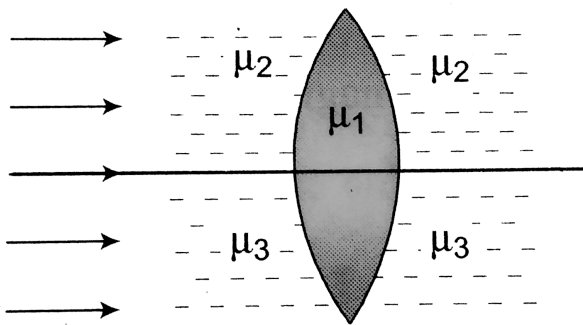

A. a single convergent beam

B. two different convergent beams

C. two different divergent beams

D. a convergent and a divergent beam.

Answer: D



Watch Video Solution

32. A double convex lens is made of glass of refractive index 1.55 with both faces of same radius of curvature. Find the radius of curvature required, if focal length is 20cm .

A. 11cm

B. 22cm

C. 7cm

D. 6cm

Answer: B



Watch Video Solution

33. What is the refractive index of material of a plano-convex lens , if the radius of curvature of

the convex surface is 10 cm and focal length of the lens is 30 cm ?

A. $\frac{6}{5}$

B. $\frac{7}{4}$

C. $\frac{2}{3}$

D. $\frac{4}{3}$

Answer: D



Watch Video Solution

34. The radii of curvature of the surfaces of a double convex lens are 20cm and 40cm respectively, and its focal length is 20cm . What is the refractive index of the material of the lens ?

A. $\frac{5}{2}$

B. $\frac{4}{3}$

C. $\frac{5}{3}$

D. $\frac{4}{5}$

Answer: C



Watch Video Solution

35. A convex lens is dipped in a liquid whose refractive index is equal to the refractive of the lens. Then its focal length will

- A. become zero
- B. become infinite
- C. remain small, but non-zero
- D. remain unchanged

Answer: B



Watch Video Solution

36. A convergent beam of light passes through a diverging lens of focal length $0.2m$ and comes to focus at a distance of $0.3m$ behind the lens. Find the position of the point at which the beam would converge in the absence of the lens.

A. $0.12m$

B. $0.6m$

C. $0.3m$

D. $0.15m$

Answer: A



Watch Video Solution

37. Radii of curvature of a converging lens are in the ratio $1:2$. Its focal length is $6cm$ and refractive index is 1.5 . Then its radii of curvature are

A. $9cm$ and $18cm$

B. 6cm and 12cm

C. 3cm and 6cm

D. 4.5cm and 9cm

Answer: D



Watch Video Solution

38. A man is trying to start a fire by focusing sunlight on a piece of paper using an equiconvex lens of focal length 10cm . The

diameter of the sun is $1.39 \times 10^9 m$ and the diameter of the sun's image on the paper is

A. $3.1 \times 10^{-4} cm$

B. $6.5 \times 10^{-5} cm$

C. $6.5 \times 10^{-4} m$

D. $9.2 \times 10^{-4} m$

Answer: D



Watch Video Solution

39. A square card of side length 1 mm is being seen through a magnifying lens of focal length 10 cm. The card is placed at a distance of 9 cm from the lens. The appaent area of the card thorough the lens is

A. 1cm^2

B. 0.81cm^2

C. 0.27cm^2

D. 0.60cm^2

Answer: A



Watch Video Solution

40. A converging lens is used to form an image on a screen. When the upper half of the lens is covered by an opaque screen

- A. half the image will disappear
- B. complete image will disappear
- C. intensity of image will decrease
- D. intensity of image will increase

Answer: C



Watch Video Solution

41. Which of the following form(s) a virtual and erect image for all position of the object?

- A. Concave lens
- B. Concave mirror
- C. Convex mirror
- D. Both (a) and (c)

Answer: D



42. A real image of a distant object is formed by a plano-convex lens of its principal axis.

Spherical aberration

A. absent

B. smaller, if the curved surface of the lens face the object.

C. smaller, if the plane surface of the lens faces the object.

D. same, which ever side of the lens faces the object.

Answer: B



Watch Video Solution

43. An object is placed at a distance of $1.5m$ from a screen and a convex lens is interposed between them. The magnification produced is 4. What is the focal length of the lens ?

A. $1m$

B. $0.5m$

C. $0.24m$

D. $2m$

Answer: C



Watch Video Solution

44. The image of a needle placed $45cm$ from a lens is formed on a screen placed $90cm$ on the

other side of lens. Find displacement of image if object is moved 5cm away from lens.

- A. 10cm , towards the lens
- B. 15cm , away from the lens
- C. 15cm , towards the lens
- D. 10cm , away from the lens

Answer: C



Watch Video Solution

45. A tree is $18.0m$ away from $2.0m$ high from a concave lens. How high is the image formed by the given lens of focal length $6m$?

A. $1.0m$

B. $1.5m$

C. $0.75m$

D. $0.50m$

Answer: D



Watch Video Solution

46. A luminous object is separated from a screen by distance d . A convex lens is placed between the object and the screen such that it forms a distinct image on the screen. The maximum possible focal length of this convex lens is.

A. $4d$

B. $2d$

C. $d/2$

D. $d/4$

Answer: D



Watch Video Solution

47. A screen is placed 90cm from an object. The image of the object on the screen is formed by a convex lens at two different location separated by 20cm . Determine the focal length of the lens.

A. 42.8cm

B. 21.4cm

C. 10.7cm

D. 5.5cm

Answer: B



Watch Video Solution

48. A lens having focal length f and aperture of diameter d forms an image of intensity I . Aperture of diameter $d/2$ in central region of lens is covered by a black paper. Focal length

of lens and intensity of image now will be respectively

A. f and $\frac{I}{4}$

B. $\frac{3f}{4}$ and $\frac{I}{2}$

C. f and $\frac{3I}{4}$

D. $\frac{f}{2}$ and $\frac{I}{2}$

Answer: C



Watch Video Solution

49. A thin convex lens of focal length 25cm is cut into two pieces 0.5cm above the principal axis. The top part is placed at $(0,0)$ and an object placed at $(-50\text{cm}, 0)$. Find the coordinates of the image.

A. $(50\text{cm}, -2\text{cm})$

B. $(50\text{cm}, -1\text{cm})$

C. $(3\text{cm}, -50\text{cm})$

D. $(60\text{cm}, -25\text{cm})$

Answer: B



Watch Video Solution

50. A double convex lens made of glass of refractive index 1.56 has both radii of curvature of magnitude 20cm . If an object is placed at a distance of 10cm from this lens, find the position of image formed.

- A. 22.86 same side of the object
- B. 22.86 opposite side of the object
- C. 44.89 same side of the object

D. 44.89 opposite side of the object.

Answer: A



Watch Video Solution

51. The power of a biconvex lens is 10 diopetre and the radius of curvature of each surface is 10 cm. Then the refractive index of the material of the lens is

A. $\frac{3}{2}$

B. $\frac{4}{3}$

C. $\frac{9}{8}$

D. $\frac{5}{3}$

Answer: A



Watch Video Solution

52. A thin glass (refractive index 1.5) lens has optical power of $-8D$ in air, its optical power in a liquid medium with refractive index 1.6 will be

A. $1D$

B. $-1D$

C. $25D$

D. $-25D$

Answer: A



Watch Video Solution

53. The radius curvature of each surface of a convex lens of refractive index 1.5 is 40 cm. Calculate its power.

A. $2.5D$

B. $2D$

C. $1.5D$

D. $1D$

Answer: A



Watch Video Solution

54. Two lenses of focal lengths 20cm and -40cm are held in contact. The

image of an object at infinity will be formed by
the combination at

A. 10cm

B. 20cm

C. 40 cm

D. infinity

Answer: C



Watch Video Solution

55. An eye specialist prescribes spectacles having combination of convex lens of focal length 40cm in contact with a concave lens of focal length 25cm. The power of this lens combination in diopters is

A. $+1.5D$

B. $-1.5D$

C. $+6.67D$

D. $-6.67D$

Answer: B



Watch Video Solution

56. Two lenses of power $+10D$ and $-5D$ are placed in contact,

(i) Calculate the focal length of the combination

(ii) where should an object be held from the combination so as to obtain a virtual image of magnification 2?

A. $5cm$

B. $-5cm$

C. 10cm

D. -10cm

Answer: D



Watch Video Solution

57. A real image of an object is formed at a distance of 20cm from a lens. On putting another lens in contact with it, the image is shifted 10cm towards the combination, Determine the power of the second lens.

A. 2D

B. 5D

C. 6D

D. 10 D

Answer: B



Watch Video Solution

58. A concave lens is placed in contact with a convex lens of focal length 25cm . The combination produces a real image at a

distance of 80cm , when an object is at a distance of 40cm . What is the focal length of concave lens ?

A. -400cm

B. -200cm

C. $+400\text{cm}$

D. $+200\text{cm}$

Answer: A



Watch Video Solution

59. Two identical glass ($\mu_g = 3/2$) equiconvex lenses of focal length f are kept in contact. The space between the two lenses is filled with water ($\mu_w = 4/3$). The focal length of the combination is

A. f

B. $\frac{f}{2}$

C. $\frac{4f}{3}$

D. $\frac{3f}{4}$

Answer: D



60. A convex lens of focal length 15 cm is placed on a plane mirror. An object is placed at 30 cm from the lens. The image is

- A. real, at 30 cm in front of the mirror
- B. real, at 30 cm behind the mirror
- C. real, at 10 cm in front of the mirror
- D. virtual, at 10 cm behind the mirror

Answer: C



Watch Video Solution

61. In the given figure, the radius of curvature of curved surface for both the plano-convex and plano-concave lens is 10 cm and refractive index for both is 1.5. The location of the final image after all the refractions through lenses is

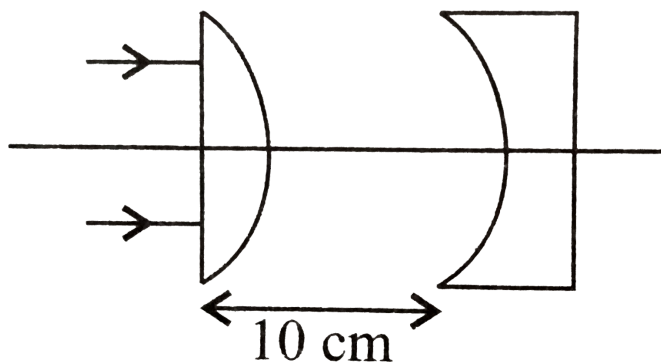

A. 15 cm

B. 20 cm

C. 25 cm

D. 40 cm

Answer: B



Watch Video Solution

62. A convex lens of radii of curvature 20cm and 30 cm respectively. It is silvered at the

surface which has smaller radius of curvature.

Then it will behave as ($\mu_g = 1.5$)

A. concave mirror with equivalent focal

$$\text{length } \frac{30}{11} \text{ cm.}$$

B. concave mirror with equivalent focal

$$\text{length } \frac{60}{11} \text{ cm.}$$

C. convex mirror with equivalent focal

$$\text{length } \frac{30}{11} \text{ cm.}$$

D. convex mirror with equivalent focal

$$\text{length } \frac{60}{11} \text{ cm.}$$

Answer: B



Watch Video Solution

63. A concave mirror of focal length f_1 is placed at a distance of d from a convex lens of focal length f_2 . A beam of light coming from infinity and falling on this convex lens-concave mirror combination returns to infinity. The distance d must equal.

A. $f_1 + f_2$

B. $-f_1 + f_2$

C. $2f_1 + f_2$

D. $-2f_1 + f_2$

Answer: C



Watch Video Solution

64. A plano convex lens has focal length $f = 20\text{cm}$. If its plane surface is silvered, then new focal length will be

A. 20cm

B. 40 cm

C. 30 cm

D. 10 cm

Answer: D



Watch Video Solution

65. Two beam of red and violet colors are made to pass separately through a prism (angle of the prism is 60°). In the position of

minimum deviation, the angle of refraction will be

- A. 30° for both the colors
- B. greater for the violet color
- C. greater for the red color
- D. equal but not 30° for both the colors

Answer: A



Watch Video Solution

66. A ray of light passes through an equilateral prism (refractive index 1.5) such that angle of incidence is equal to angle of emergence and the latter is equal to $\frac{3}{4}$ th of the angle of prism. Calculate the angle of deviation.

A. 60°

B. 30°

C. 45°

D. 120°

Answer: B



Watch Video Solution

67. A ray of light is incident at small angle I on the surface of prism of small angle A and emerges normally from the opposite surface. If the refractive index of the material of the prism is μ , the angle of incidence is nearly equal to

A. $\frac{A}{\mu}$

B. $\frac{A}{2\mu}$

C. μA

D. $\frac{\mu A}{2}$

Answer: C



Watch Video Solution

68. The angle of minimum deviation for prism of angle $\pi/3$ is $\pi/6$. Calculate the velocity of light in the material of the prism if the velocity of light in vacuum is $3 \times 10^8 \text{ms}^{-1}$.

A. $2.12 \times 10^8 \text{ms}^{-1}$

B. $1.12 \times 10^8 \text{ms}^{-1}$

C. $4.12 \times 10^8 \text{ms}^{-1}$

D. $5.12 \times 10^8 \text{ms}^{-1}$

Answer: A



Watch Video Solution

69. The angle of minimum deviation for a glass prism with $\mu = \sqrt{3}$ equals the refracting angle of the prism. What is the angle of the prism?

A. 45°

B. 30°

C. 90°

D. 60°

Answer: D



Watch Video Solution

70. A ray of light is incident at 60° on one face of a prism of angle 30° and the emergent ray

makes 30° with the incident ray. The refractive index of the prism is

A. 1.732

B. 1.414

C. 1.5

D. 1.33

Answer: A



Watch Video Solution

71. A small angled prism ($\mu = 1.62$) gives a deviation of 4.8 . Calculate the angle of prism.

A. 5°

B. 6.36°

C. 3°

D. 7.74°

Answer: D



Watch Video Solution

72. Which of the following colours of white light deviated most when passes through a prism ?

A. Red light

B. Violet light

C. Yellow light

D. Both (a) and (b)

Answer: B



Watch Video Solution

73. White light is incident normally on a glass slab. Inside the glass slab,

A. red light travels faster than other colours

B. violet light travels faster than other colours

C. yellow light travels faster than other colours

D. all colours travels with the same speed.

Answer: A



Watch Video Solution

74. Which light rays undergoes two internal reflection inside a raindrop, which of the rainbow is formed?

- A. Primary rainbow
- B. Secondary rainbow
- C. Both (a) and (b)
- D. Cant's say

Answer: B



Watch Video Solution

75. Which of the following satatment is correct ?

A. At sunset or sunrise, the sun's rays have to pass through a small distance in the atmosphere .

B. At sunset or sunrise the sun's rays have to pass through a larger distance in the atmosphere.

C. Rayleigh scattering which is proportional to $(1/\lambda^2)$

D. Most of the blue and other shorter wavelengths are not removed by scattering.

Answer: B



Watch Video Solution

76. When objects at different distances are seen by the eye, which of the following remains constant?

- A. the focal length of the eyes lens
- B. the objects distance from the eye lens
- C. the radii of curvature of the eye lens
- D. the image distance from the eye lens

Answer: D



Watch Video Solution

77. An under-water swimmer cannot see very clearly even in absolutely clear water because of

- A. absorption of light in water
- B. scattering of light in water
- C. reduction of speed of light in water
- D. change in the focal length of eye lens

Answer: D



Watch Video Solution

78. The nearer point of hypermetropic eye is 40cm . The lens to be used for its correction should have the power

A. $+1.5D$

B. $-1.5D$

C. $+2.5D$

D. $+0.5D$

Answer: C



Watch Video Solution

79. When a telescope is in normal adjustment, the distance of the objective from the eyepiece is found to 100cm . If the magnifying power of the telescope, at normal adjustment, is 24 focal lengths of the lenses are

A. 96 cm, 4 cm

B. 48 cm, 2 cm

C. 50 cm, 50 cm

D. 80 cm, 20 cm

Answer: A



Watch Video Solution

80. A compound microscope consists of an objective lens with focal length 1.0cm and eye piece of the focal length 2.0 cm and a tube 20cm from eye lens. Now final image is formed at the near point of eye, so find the magnifying power of microscope.

A. 300cm

B. 232cm

C. 290cm

D. 270cm

Answer: C



Watch Video Solution

81. In a compound microscope, the focal lengths of two lenses are 1.5cm and 6.25cm an object is placed at 2cm form objective and

the final image is formed at 25cm from eye lens. The distance between the two lenses is

A. 6.00cm

B. 7.75cm

C. 9.25cm

D. 11.0cm

Answer: D



Watch Video Solution

82. A person with a normal near point (25cm) using a compound microscope with an objective of focal length 8.0mm and eye piece of focal length 2.5cm can bring an object placed 9.0cm from the objective in sharp focus. What is the separation between the two lenses ? Calculate the magnifying power of the microscope ?

A. 9.47cm , 88

B. 3.36cm , 44

C. 6.00cm , 22

D. 4.79cm , 11

Answer: A



Watch Video Solution

83. The final image in an astronomical telescope adjustment, a straight black line of length L is drawn on the objective lens. The eyepiece forms a real image of this line. The length of this image is l . The magnification of the telescope is

A. virtual and erect

B. real and erect

C. real and inverted

D. virtual and inverted

Answer: D



Watch Video Solution

84. In an astronomical telescope in normal adjustment a straight black line of length L is drawn on inside part of objective lens. The eye

piece forms a real image of this line. The length of this image is I . The magnification of the telescope is

A. $\frac{L}{l}$

B. $\frac{L}{l} + 1$

C. $\frac{L}{l} - 1$

D. $\frac{L + l}{L - l}$

Answer: A



Watch Video Solution

85. The focal length of the lenses of an astronomical telescope are 50 cm and 5 cm. The length of the telescope when the image is formed at the least distance of distinct vision is

A. 45cm

B. 55cm

C. $\frac{275}{6}\text{cm}$

D. $\frac{325}{6}\text{cm}$

Answer: D



86. A small telescope has an objective lens of focal length 144cm and an eye-piece of focal length 6.0cm . What is the magnifying power of the telescope ? What is the separation between the objective and the eye-piece ?

A. 0.75cm

B. 1.38cm

C. 1.0m

D. 1.5m

Answer: D



Watch Video Solution

87. An astronomical refractive telescope has an objective of focal length 20 m and an eyepiece of focal length 2 cm. Then

A. the magnification is 1000

B. the length of the telescope tube is 20.02
m

C. the image formed is inverted

D. all of these.

Answer: D



Watch Video Solution

88. A giant reflecting telescope at an observatory has an objective lens of focal length $15m$. If an eye piece lens of focal length $1cm$ is used, find the angular magnification of the telescope.

If this telescope is used to view the moon,

what is the diameter of image of moon formed by objective lens ? The diameter of the moon is $3.42 \times 10^6 m$ and radius of lunar orbit is $3.8 \times 10^8 m$.

A. 1000

B. 1500

C. 2000

D. 3000

Answer: B



Watch Video Solution

89. A small telescope has an objective lens of focal length 140 cm and an eyepiece of focal length 5.0 cm. what is the magnifying power of the telescope for viewing distant objects when

(a) the telescope is in normal adjustment (i.e, when the final image is at infinity),

(b) The final image is formed at the least distance of distinct vision (25 cm)

A. 33.6

B. 66.12

C. 22.6

D. 11.6

Answer: A



Watch Video Solution

90. A reflecting type telescope has a large concave spherical mirror of radius of curvature 80cm as objective. What is the magnifying power of telescope if eye piece used has a focal length of 1.6cm ?

A. 100

B. 50

C. 25

D. 5

Answer: C



Watch Video Solution

91. A giant telescope in an observatory has an objective of focal length 19 m and an eye-piece of focal length 1.0cm. In normal adjustment,

the telescope is used to view the moon. What is the diameter of the image of the moon formed by the objective? The diameter of the moon is $3.5 \times 10^6 m$. and the radius of the lunar orbit round the earth is $3.8 \times 10^8 m$.

A. $10cm$

B. $12.5cm$

C. $15cm$

D. $17.5cm$

Answer: D



92. A ray of light travelling in the direction $\frac{1}{2}(\hat{i} + \sqrt{3}\hat{j})$ is incident on a plane mirror. After reflection, it travels along the direction $\frac{1}{2}(\hat{i} - \sqrt{3}\hat{j})$. The angle of incidence is

A. 30°

B. 45°

C. 60°

D. 75°

Answer: A



Watch Video Solution

93. The number of capital letters such as *A, B, C, D.....* which are not laterally inverted by a plane mirror ?

A. 6

B. 7

C. 11

D. 13

Answer: C



Watch Video Solution

94. Two mirrors at an angle θ° produce 5 images of a point. The number of images produced when θ is decreased to $\theta^\circ - 30^\circ$ is

- A. 9
- B. 10
- C. 11
- D. 12

Answer: C



Watch Video Solution

95. A man stands symmetrically between two large plane mirrors fixed to two adjacent walls of a rectangular room. The number of images formed as

A. 4

B. 3

C. 2

D. 6

Answer: B



Watch Video Solution

96. Two plane mirrors M_1 and M_2 are inclined at angle as shown in Figure . A ray of light 1, which is parallel to M_1 , strike M_2 and after two reflections, ray 2 becomes parallel to M_2 .

Find the angle θ .

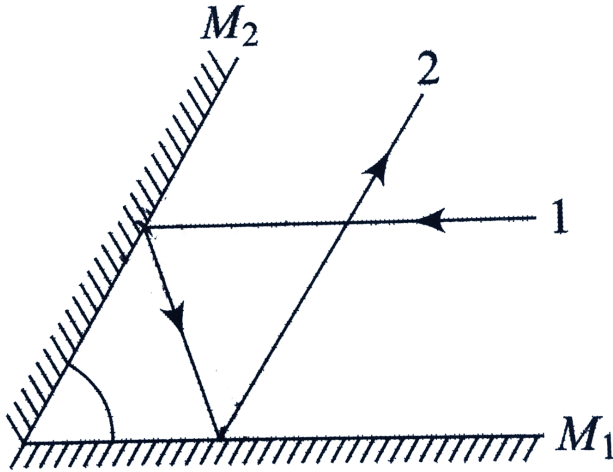

A. 0°

B. 30°

C. 45°

D. 60°

Answer: D

97. Two plane mirrors are placed parallel to each other at a distance L apart. A point object O placed between them, at a distance $L/3$ from one mirror. Both mirrors form multiple image. The distance between any two images cannot be

A. $\frac{3L}{2}$

B. $\frac{2L}{3}$

C. $2L$

D. L

Answer: A



Watch Video Solution

98. Four identical mirrors are made to stand vertically to form a square arrangement as shown in a top view. A ray starts from the midpoint M of mirror AD and after two reflections reaches corner D . Then, angle θ

must be

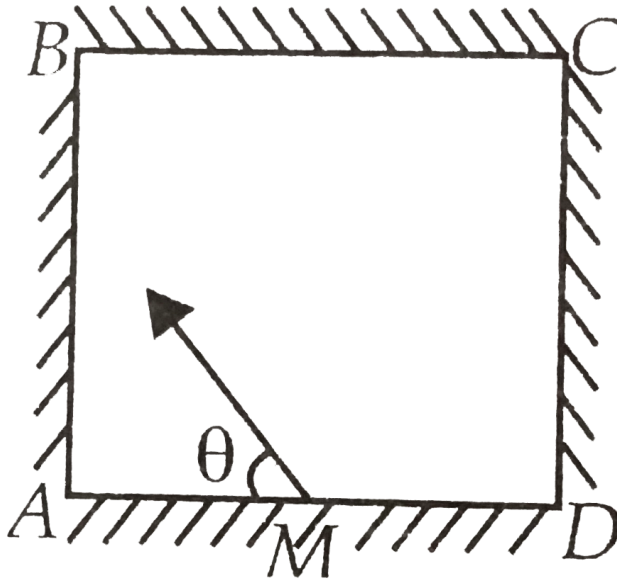

A. $\tan^{-1}(0.75)$

B. $\cot^{-1}(0.75)$

C. $\sin^{-1}(0.75)$

D. $\cos^{-1}(0.75)$

Answer: B



Watch Video Solution

99. Light incident normally on a plane mirror attached to a galvanometer coil reflects backward as shown in figure. A current in the coil produces a deflection of 3.5° of the mirror. The displacement of the reflected spot of light

on a screen placed 2.0m away is

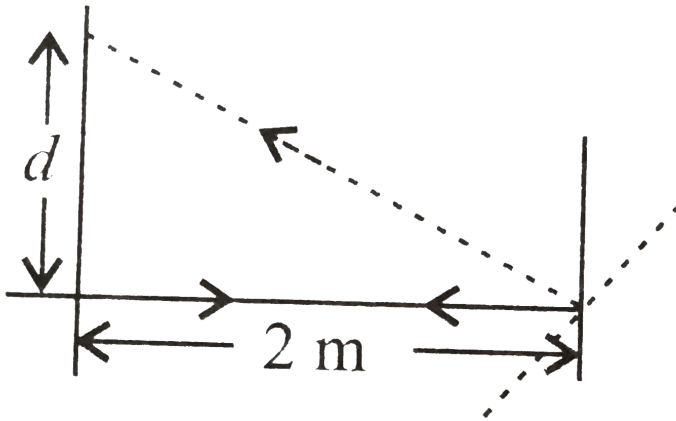

- A. 27.5m
- B. 48.9cm
- C. 24.5cm
- D. 12.2m

Answer: C



Watch Video Solution

100. A plane mirror is placed along the x-axis facing negative y-axis. The mirror is fixed, A point object is moving with $3\hat{i} + 4\hat{j}$ in front of the plane mirror. The relative velocity of image with respect to its object is

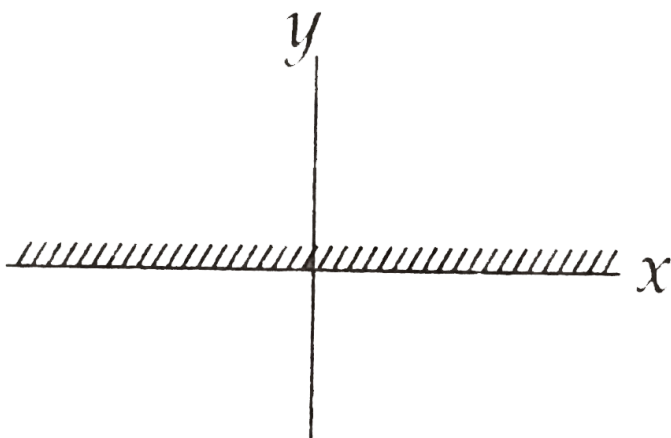

A. $-8\hat{j}$

B. $8\hat{j}$

C. $3\hat{i} - 4\hat{j}$

D. $-6\hat{i}$

Answer: A



Watch Video Solution

Reflection Of Light By Spherical Mirrors

1. A boy of height 1m stands in front of a convex mirror. His distance from the mirror is equal to its focal length. The height of his image is

A. $0.25m$

B. $0.33m$

C. $0.5m$

D. $0.67m$

Answer: C



Watch Video Solution

2. A concave shaving mirror has a radius of curvature of 35.0cm . It is positioned so that the (upright) image of man's face is 2.50 times the size of the face. How far is the mirror from the face ?

A. 5.25cm

B. 21.0cm

C. 10.5cm

D. 42cm

Answer: C



Watch Video Solution

3. A rod of length 10 cm lies along the principal axis of a concave mirror of focal length 10 cm in such a way that the end closer to the pole is 20 cm away from it. Find the length of the image.

A. 10cm

B. 15cm

C. 2.5cm

D. 5cm

Answer: D



Watch Video Solution

4. An object 2cm high is placed at a distance of 16cm from a concave mirror, which produces a real image 3cm high. What is the focal length of the mirror? Find the position of the image?

A. -9.6cm

B. -3.6cm

C. -6.3cm

D. -8.3cm

Answer: A



Watch Video Solution

5. When an object is kept at a distance of 30cm from a concave mirror, the image is formed at a distance of 10 cm. If the object is

moved with a speed of $9ms^{-1}$ the speed with which the image moves is

A. $10ms^{-1}$

B. $1ms^{-1}$

C. $9ms^{-1}$

D. $0.9ms^{-1}$

Answer: B



Watch Video Solution

1. A microscope is focused on a mark on a piece of paper and then a slab of glass of thickness 3cm and refractive index 1.5 is placed over the mark. How should the microscope be moved to get the mark in focus again ?

A. 4.5cm downward

B. 1cm downward

C. 2cm downward

D. 1cm upward

Answer: D



Watch Video Solution

2. Refraction of light from air to glass and from air to water are shown in figure (i) and figure (ii) below. The value of the angle θ in the case of refraction as shown in figure (iii) will be

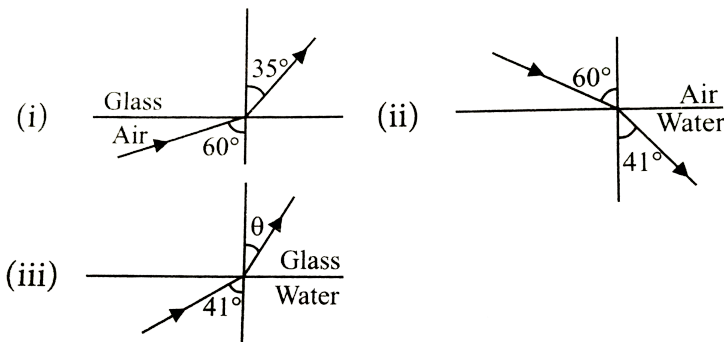

A. 30°

B. 35°

C. 60°

D. 41°

Answer: B



Watch Video Solution

3. A ray of light strikes a transparent rectangular slab of refractive index $\sqrt{2}$ at an

angle of incidence of 45° . The angle between the reflected and refracted rays is

A. 75°

B. 90°

C. 105°

D. 120°

Answer: C



Watch Video Solution

4. A rays of light is incident on a thick slab of glass of thickness t as shown in figure. The emergent ray is parallel to the incident ray but displaced sideways by a distance d . If the angles are small then d is

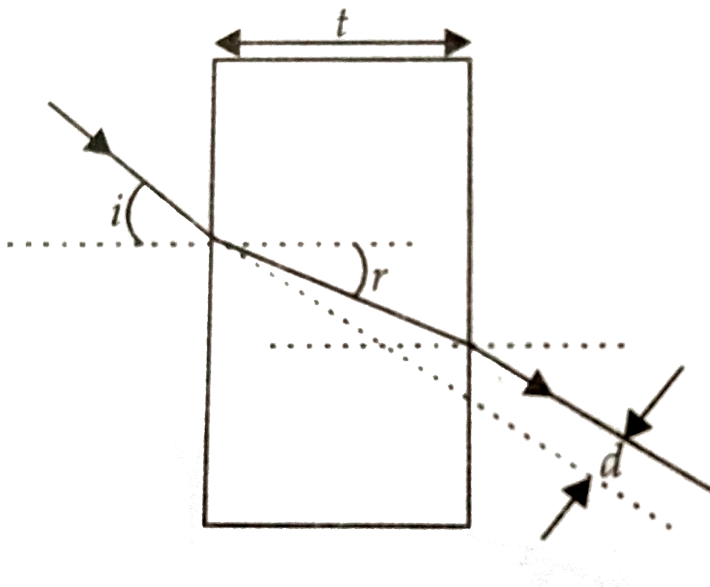

A. $t \left(1 + \frac{i}{r} \right)$

B. $rt \left(1 - \frac{i}{r} \right)$

C. $it \left(1 - \frac{r}{i} \right)$

D. $t \left(1 + \frac{r}{i} \right)$

Answer: C



Watch Video Solution

5. A ray incident at a point at an angle of incidence of 60° enters a glass sphere with refractive index $\sqrt{3}$ and it is reflected and

refracted at the farther surface of the sphere.

The angle between the reflected and refracted rays at this surface is:

A. 50°

B. 60°

C. 90°

D. 40°

Answer: C



Watch Video Solution

6. The apparent depth of a needle laying at the bottom of the tank, which is filled with water of refractive index 1.33 to a height of 12.5 cm is measured by a microscope to be 9.4cm. If water is replaced by a liquid of refractive index 1.63 upto the same height. What distance would the microscope have to be moved to focus on the needle again ?

A. 1.73cm

B. 2.13cm

C. 1.5cm

D. 2.9cm

Answer: A



Watch Video Solution

7. A point luminous object (O) is at a distance h from front face of a glass slab of width d and of refractive index μ . On the back face of slab is a reflecting plane mirror. An observer sees the image of object in mirror as shown in figure. Distance of image from front face as

seen by observer will be

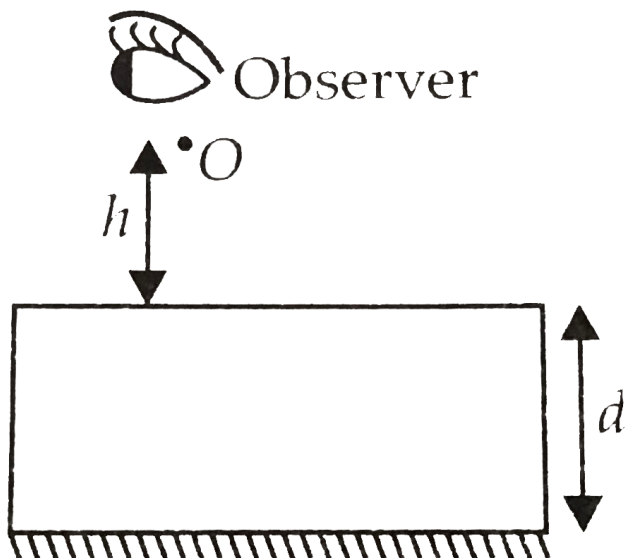

A. $h + \frac{2d}{\mu}$

B. $2h + 2d$

C. $h + d$

D. $h + \frac{d}{\mu}$

Answer: A



Watch Video Solution

8. A vessel of depth x is half filled with oil of refractive index μ_1 and the other half is filled with water of refractive index μ_2 . The apparent depth of the vessel when viewed above is

A.
$$\frac{x(\mu_1 + \mu_2)}{2\mu_1\mu_2}$$

B.
$$\frac{x\mu_1\mu_2}{2(\mu_1 + \mu_2)}$$

C.
$$\frac{x\mu_1\mu_2}{(\mu_1 + \mu_2)}$$

D. $\frac{2x(\mu_1 + \mu_2)}{\mu_1\mu_2}$

Answer: A



Watch Video Solution

9. Three immiscible liquids of densities $d_1 > d_2 > d_3$ and refractive indices $\mu_1 > \mu_2 > \mu_3$ are put in a beaker. The height of each liquid column is $\frac{h}{3}$. A dot is made at the bottom of the beaker. For near normal vision, find the apparent depth of the dot.

A. $\frac{h}{6} \left(\frac{1}{\mu_1} + \frac{1}{\mu_2} + \frac{1}{\mu_3} \right)$

B. $\frac{h}{6} \left(\frac{1}{\mu_1} - \frac{1}{\mu_2} - \frac{1}{\mu_3} \right)$

C. $\frac{h}{3} \left(\frac{1}{\mu_1} - \frac{1}{\mu_2} - \frac{1}{\mu_3} \right)$

D. $\frac{h}{3} \left(\frac{1}{\mu_1} + \frac{1}{\mu_2} + \frac{1}{\mu_3} \right)$

Answer: D



Watch Video Solution

10. A tank is filled with water to a height of 15.5cm . The apparent depth of a needle lying at the bottom of the tank is measured by a

microscope to be 8.5cm . If water is replaced by a liquid of refractive index 1.94 upto the same height by what distance would the microscope have to be moved to focus on the needle again ?

A. 1.00cm

B. 2.37cm

C. 0.51cm

D. 3.93cm

Answer: C



Total Internal Reflection

1. For a total internal reflection, which of the following is correct ?

A. Light travel from rarer to denser medium.

B. Light travel from denser to rarer medium.

C. Light travels in air only.

D. Light travels in water only.

Answer: B



Watch Video Solution

2. Light travels in two media A and B with speeds $1.8 \times 10^8 \text{ms}^{-1}$ and $2.4 \times 10^8 \text{ms}^{-1}$ respectively. Then the critical angle between them is

A. $\sin^{-1}\left(\frac{2}{3}\right)$

B. $\tan^{-1}\left(\frac{3}{4}\right)$

C. $\tan^{-1}\left(\frac{2}{3}\right)$

D. $\sin^{-1}\left(\frac{3}{4}\right)$

Answer: D



Watch Video Solution

3. Critical angle of glass is θ_1 and that of water is θ_2 . The critical angle for water and glass surface would be $(\mu_g = 3/2, \mu_w = 4/3)$

- A. less than θ_2
- B. between θ_1 and θ_2
- C. greater than θ_2
- D. less than θ_1

Answer: C



Watch Video Solution

4. Critical angle for light going from medium (i) to (ii) is θ . The speed of light in medium (i) is v then speed in medium (ii) is

A. $v(1 - \cos \theta)$

B. $\frac{v}{\sin \theta}$

C. $\frac{v}{\cos \theta}$

D. $\frac{v}{(1 - \sin \theta)}$

Answer: B



Watch Video Solution

5. A ray of light travelling in a transparent medium of refractive index μ , falls on a surface separating the medium from air at an angle of

incidence of 45° . For which of the following value of μ the ray can undergo total internal reflection ?

A. $\mu = 1.33$

B. $\mu = 1.40$

C. $\mu = 1.50$

D. $\mu = 1.25$

Answer: C



Watch Video Solution

6. A point source of light is placed at a depth of h below the surface of water of refractive index μ . A floating opaque disc is placed on the surface of water so that light from the source is not visible from the surface. The minimum diameter of the disc is

A. $\frac{2h}{(\mu^2 - 1)^{1/2}}$

B. $2h(\mu^2 - 1)^{1/2}$

C. $\frac{h}{2(\mu^2 - 1)^{1/2}}$

D. $h(\mu^2 - 1)^{1/2}$

Answer: A



Watch Video Solution

7. Mirage' is a phenomenon due to

- A. refraction of light
- B. reflection of light
- C. total internal reflection of light
- D. diffraction of light.

Answer: C



Watch Video Solution

Reflection At Spherical Surfaces And By Lenses

1. From a point source a light falls on a spherical glass surface ($\mu = 1.5$ and radius of curvature = 10cm). The distance between point source and glass surface is 50cm . The position of image is

A. 25cm

B. 50cm

C. 100cm

D. 150cm

Answer: B



Watch Video Solution

2. An air bubble in a glass sphere ($\mu = 1.5$) is situated at a distance 3cm from a convex surface of diameter 10cm . At what distance from the surface will the bubble appear ?

A. 2.5cm

B. -2.5cm

C. 5cm

D. -5cm

Answer: B



Watch Video Solution

3. A convex refracting surface of radius of curvature 20cm separates two media of refractive indices $4/3$ and 1.60 . An object is

placed in the first medium ($\mu = 4/3$) at a distance of 200cm from the refracting surface.

Calculate the position of image formed.

A. 120cm

B. 240cm

C. 100cm

D. 60cm

Answer: B



Watch Video Solution

4. Light from a point source in air falls on a spherical glass surface. If $\mu = 1.5$, and radius of curvature = 20cm , the distance of light source from the glass surface is 100cm , at what position will the image be formed ?
(NCERT Solved Example)

A. 25cm

B. 50cm

C. 100cm

D. 200cm

Answer: C



Watch Video Solution

5. A mark placed on the surface of a sphere is viewed through glass from a position directly opposite. If the diameter of the sphere is 10cm and refractive index of glass is 1.5 , find the position of the image.

A. -20cm

B. 30cm

C. 40cm

D. -10cm

Answer: A



Watch Video Solution

6. A biconvex lens has focal length $\frac{2}{3}$ times the radius of curvature of either surface. Calculate refraction index of material of the lens.

A. 1.75

B. 1.33

C. 1.5

D. 1.0

Answer: A



Watch Video Solution

7. A convex lens of focal length $0.2m$ and made of glass ($\mu = 1.50$) is immersed in water

($\mu = 1.33$). Find the change in the focal length of the lens.

A. $5.8m$

B. $0.58cm$

C. $0.58m$

D. $5.8cm$

Answer: C



Watch Video Solution

8. A double convex lens, lens made of a material of refractive index μ_1 , is placed inside two liquids or refractive indices μ_2 and μ_3 , as shown. $\mu_2 > \mu_1 > \mu_3$. A wide, parallel beam of light is incident on the lens from the left. The lens will give rise to

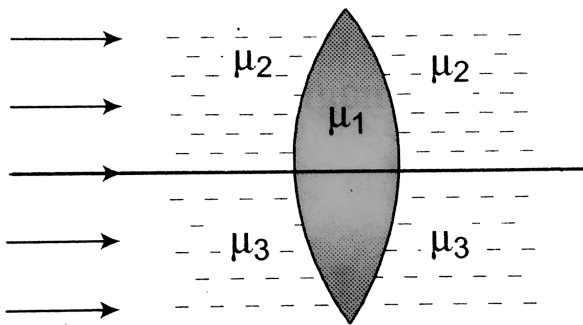

A. a single convergent beam

B. two different convergent beams

C. two different divergent beams

D. a convergent and a divergent beam.

Answer: D



Watch Video Solution

9. A double convex lens is made of glass of refractive index 1.55 with both faces of same radius of curvature. Find the radius of curvature required, if focal length is 20cm .

A. 11cm

B. 22cm

C. 7cm

D. 6cm

Answer: B



Watch Video Solution

10. What is the refractive index of material of a plano-convex lens , if the radius of curvature of

the convex surface is 10 cm and focal length of the lens is 30 cm ?

A. $\frac{6}{5}$

B. $\frac{7}{4}$

C. $\frac{2}{3}$

D. $\frac{4}{3}$

Answer: D



Watch Video Solution

11. The radii of curvature of the surfaces of a double convex lens are 20cm and 40cm respectively, and its focal length is 20cm . What is the refractive index of the material of the lens ?

A. $\frac{5}{2}$

B. $\frac{4}{3}$

C. $\frac{5}{3}$

D. $\frac{4}{5}$

Answer: C



Watch Video Solution

12. A convex lens is dipped in a liquid whose refractive index is equal to the refractive of the lens. Then its focal length will

- A. become zero
- B. become infinite
- C. remain small, but non-zero
- D. remain unchanged

Answer: B



Watch Video Solution

13. A convergent beam of light passes through a diverging lens of focal length $0.2m$ and comes to focus at a distance of $0.3m$ behind the lens. Find the position of the point at which the beam would converge in the absence of the lens.

A. $0.12m$

B. $0.6m$

C. $0.3m$

D. $0.15m$

Answer: A



Watch Video Solution

14. Radii of curvature of a converging lens are in the ratio $1:2$. Its focal length is $6cm$ and refractive index is 1.5 . Then its radii of curvature are

A. $9cm$ and $18cm$

B. 6cm and 12cm

C. 3cm and 6cm

D. 4.5cm and 9cm

Answer: D



Watch Video Solution

15. A man is trying to start a fire by focusing sunlight on a piece of paper using an equiconvex lens of focal length 10cm . The

diameter of the sun is $1.39 \times 10^9 m$ and the diameter of the sun's image on the paper is

A. $3.1 \times 10^{-4} cm$

B. $6.5 \times 10^{-5} cm$

C. $6.5 \times 10^{-4} m$

D. $9.2 \times 10^{-4} m$

Answer: D



Watch Video Solution

16. A square card of side length 1 mm is being seen through a magnifying lens of focal length 10 cm. The card is placed at a distance of 9 cm from the lens. The appaent area of the card thorough the lens is

A. 1cm^2

B. 0.81cm^2

C. 0.27cm^2

D. 0.60cm^2

Answer: A



Watch Video Solution

17. A converging lens is used to form an image on a screen. When the upper half of the lens is covered by an opaque screen

- A. half the image will disappear
- B. complete image will disappear
- C. intensity of image will decrease
- D. intensity of image will increase

Answer: C



Watch Video Solution

18. Which of the following form(s) a virtual and erect image for all position of the object?

- A. Concave lens
- B. Concave mirror
- C. Convex mirror
- D. Both (a) and (c)

Answer: D



19. A real image of a distant object is formed by a plano-convex lens of its principal axis.

Spherical aberration

A. absent

B. smaller, if the curved surface of the lens face the object.

C. smaller, if the plane surface of the lens faces the object.

D. same, which ever side of the lens faces the object.

Answer: B



Watch Video Solution

20. An object is placed at a distance of $1.5m$ from a screen and a convex lens is interposed between them. The magnification produced is 4. What is the focal length of the lens ?

A. $1m$

B. $0.5m$

C. $0.24m$

D. $2m$

Answer: C



Watch Video Solution

21. The image of a needle placed $45cm$ from a lens is formed on a screen placed $90cm$ on the

other side of lens. Find displacement of image if object is moved 5cm away from lens.

- A. 10cm , towards the lens
- B. 15cm , away from the lens
- C. 15cm , towards the lens
- D. 10cm , away from the lens

Answer: C



Watch Video Solution

22. A tree is $18.0m$ away from $2.0m$ high from a concave lens. How high is the image formed by the given lens of focal length $6m$?

A. $1.0m$

B. $1.5m$

C. $0.75m$

D. $0.50m$

Answer: D



Watch Video Solution

23. A luminous object is separated from a screen by distance d . A convex lens is placed between the object and the screen such that it forms a distinct image on the screen. The maximum possible focal length of this convex lens is.

A. $4d$

B. $2d$

C. $d/2$

D. $d/4$

Answer: D



Watch Video Solution

24. A screen is placed 90cm from an object. The image of the object on the screen is formed by a convex lens at two different location separated by 20cm . Determine the focal length of the lens.

A. 42.8cm

B. 21.4cm

C. 10.7cm

D. 5.5cm

Answer: B



Watch Video Solution

25. A lens having focal length f and aperture of diameter d forms an image of intensity I . Aperture of diameter $d/2$ in central region of lens is covered by a black paper. Focal length

of lens and intensity of image now will be respectively

A. f and $\frac{I}{4}$

B. $\frac{3f}{4}$ and $\frac{I}{2}$

C. f and $\frac{3I}{4}$

D. $\frac{f}{2}$ and $\frac{I}{2}$

Answer: C



Watch Video Solution

26. A thin convex lens of focal length 25cm is cut into two pieces 0.5cm above the principal axis. The top part is placed at $(0,0)$ and an object placed at $(-50\text{cm}, 0)$. Find the coordinates of the image.

A. $(50\text{cm}, -2\text{cm})$

B. $(50\text{cm}, -1\text{cm})$

C. $(3\text{cm}, -50\text{cm})$

D. $(60\text{cm}, -25\text{cm})$

Answer: B



Watch Video Solution

27. A double convex lens made of glass of refractive index 1.56 has both radii of curvature of magnitude 20cm . If an object is placed at a distance of 10cm from this lens, find the position of image formed.

- A. 22.86 same side of the object
- B. 22.86 opposite side of the object
- C. 44.89 same side of the object

D. 44.89 opposite side of the object.

Answer: A



Watch Video Solution

28. The power of a biconvex lens is 10 diopetre and the radius of curvature of each surface is 10 cm. Then the refractive index of the material of the lens is

A. $\frac{3}{2}$

B. $\frac{4}{3}$

C. $\frac{9}{8}$

D. $\frac{5}{3}$

Answer: A



Watch Video Solution

29. A thin glass (refractive index 1.5) lens has optical power of $-8D$ in air, its optical power in a liquid medium with refractive index 1.6 will be

A. $1D$

B. $-1D$

C. $25D$

D. $-25D$

Answer: A



Watch Video Solution

30. The radius curvature of each surface of a convex lens of refractive index 1.5 is 40 cm. Calculate its power.

A. $2.5D$

B. $2D$

C. $1.5D$

D. $1D$

Answer: A



Watch Video Solution

31. Two lenses of focal lengths 20cm and -40cm are held in contact. The

image of an object at infinity will be formed by
the combination at

A. 10cm

B. 20cm

C. 40 cm

D. infinity

Answer: C



Watch Video Solution

32. An eye specialist prescribes spectacles having combination of convex lens of focal length 40cm in contact with a concave lens of focal length 25cm. The power of this lens combination in diopters is

A. $+1.5D$

B. $-1.5D$

C. $+6.67D$

D. $-6.67D$

Answer: B



Watch Video Solution

33. Two lenses of power $+10D$ and $-5D$ are placed in contact,

(i) Calculate the focal length of the combination

(ii) where should an object be held from the combination so as to obtain a virtual image of magnification 2?

A. $5cm$

B. $-5cm$

C. 10cm

D. -10cm

Answer: D



Watch Video Solution

34. A real image of an object is formed at a distance of 20cm from a lens. On putting another lens in contact with it, the image is shifted 10cm towards the combination, Determine the power of the second lens.

A. 2D

B. 5D

C. 6D

D. 10 D

Answer: B



Watch Video Solution

35. A concave lens is placed in contact with a convex lens of focal length 25cm . The combination produces a real image at a

distance of 80cm , when an object is at a distance of 40cm . What is the focal length of concave lens ?

A. -400cm

B. -200cm

C. $+400\text{cm}$

D. $+200\text{cm}$

Answer: A



Watch Video Solution

36. Two identical glass ($\mu_g = 3/2$) equiconvex lenses of focal length f are kept in contact. The space between the two lenses is filled with water ($\mu_w = 4/3$). The focal length of the combination is

A. f

B. $\frac{f}{2}$

C. $\frac{4f}{3}$

D. $\frac{3f}{4}$

Answer: D



Watch Video Solution

37. A convex lens of focal length 15 cm is placed on a plane mirror. An object is placed at 30 cm from the lens. The image is

- A. real, at 30 cm in front of the mirror
- B. real, at 30 cm behind the mirror
- C. real, at 10 cm in front of the mirror
- D. virtual, at 10 cm behind the mirror

Answer: C



Watch Video Solution

38. In the given figure, the radius of curvature of curved surface for both the plano-convex and plano-concave lens is 10 cm and refractive index for both is 1.5. The location of the final image after all the refractions through lenses is

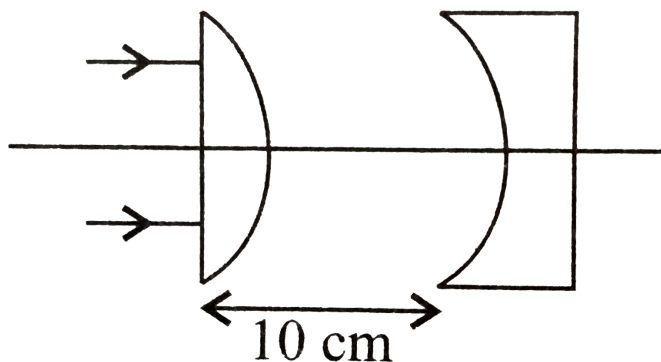

A. 15 cm

B. 20 cm

C. 25 cm

D. 40 cm

Answer: B



Watch Video Solution

39. A convex lens of radii of curvature 20cm and 30 cm respectively. It is silvered at the

surface which has smaller radius of curvature.

Then it will behave as ($\mu_g = 1.5$)

A. concave mirror with equivalent focal

$$\text{length } \frac{30}{11} \text{ cm.}$$

B. concave mirror with equivalent focal

$$\text{length } \frac{60}{11} \text{ cm.}$$

C. convex mirror with equivalent focal

$$\text{length } \frac{30}{11} \text{ cm.}$$

D. convex mirror with equivalent focal

$$\text{length } \frac{60}{11} \text{ cm.}$$

Answer: B



Watch Video Solution

40. A concave mirror of focal length f_1 is placed at a distance of d from a convex lens of focal length f_2 . A beam of light coming from infinity and falling on this convex lens-concave mirror combination returns to infinity. The distance d must equal.

A. $f_1 + f_2$

B. $-f_1 + f_2$

C. $2f_1 + f_2$

D. $-2f_1 + f_2$

Answer: C



Watch Video Solution

41. A plano convex lens has focal length $f = 20\text{cm}$. If its plane surface is silvered, then new focal length will be

A. 20cm

B. 40 cm

C. 30 cm

D. 10 cm

Answer: D



Watch Video Solution

Refraction Through A Prism

1. Two beam of red and violet colors are made to pass separately through a prism (angle of the prism is 60°). In the position of minimum deviation, the angle of refraction will be

- A. 30° for both the colors
- B. greater for the violet color
- C. greater for the red color
- D. equal but not 30° for both the colors

Answer: A



Watch Video Solution

2. A ray of light passes through an equilateral prism (refractive index 1.5) such that angle of incidence is equal to angle of emergence and the latter is equal to $3/4$ th of the angle of prism. Calculate the angle of deviation.

A. 60°

B. 30°

C. 45°

D. 120°

Answer: B



Watch Video Solution

3. A ray of light is incident at small angle I on the surface of prism of small angle A and emerges normally from the opposite surface. If the refractive index of the material of the prism is μ , the angle of incidence is nearly equal to

A. $\frac{A}{\mu}$

B. $\frac{A}{2\mu}$

C. μA

D. $\frac{\mu A}{2}$

Answer: C



Watch Video Solution

4. The angle of minimum deviation for prism of angle $\pi/3$ is $\pi/6$. Calculate the velocity of light in the material of the prism if the velocity of light in vacuum is $3 \times 10^8 \text{ ms}^{-1}$.

A. $2.12 \times 10^8 \text{ms}^{-1}$

B. $1.12 \times 10^8 \text{ms}^{-1}$

C. $4.12 \times 10^8 \text{ms}^{-1}$

D. $5.12 \times 10^8 \text{ms}^{-1}$

Answer: A



Watch Video Solution

5. The angle of minimum deviation for a glass prism with $\mu = \sqrt{3}$ equals the refracting

angle of the prism. What is the angle of the prism?

A. 45°

B. 30°

C. 90°

D. 60°

Answer: D



Watch Video Solution

6. A ray of light is incident at 60° on one face of a prism of angle 30° and the emergent ray makes 30° with the incident ray. The refractive index of the prism is

A. 1.732

B. 1.414

C. 1.5

D. 1.33

Answer: A



Watch Video Solution

7. A small angled prism ($\mu = 1.62$) gives a deviation of 4.8° . Calculate the angle of prism.

A. 5°

B. 6.36°

C. 3°

D. 7.74°

Answer: D



Watch Video Solution

8. Which of the following colours of white light deviated most when passes through a prism ?

A. Red light

B. Violet light

C. Yellow light

D. Both (a) and (b)

Answer: B



Watch Video Solution

9. White light is incident normally on a glass slab. Inside the glass slab,

A. red light travels faster than other colours

B. violet light travels faster than other colours

C. yellow light travels faster than other colours

D. all colours travels with the same speed.

Answer: A



Watch Video Solution

Some Natural Phenomena Due To Sunlight

1. Which light rays undergoes two internal reflection inside a raindrop, which of the rainbow is formed?

A. Primary rainbow

B. Secondary rainbow

C. Both (a) and (b)

D. Cant's say

Answer: B



Watch Video Solution

2. Which of the following satatment is correct

?

A. At sunset or sunrise, the sun's rays have

to pass through a small distance in the

atmosphere .

B. At sunset or sunrise the sun's rays have to pass through a larger distance in the atmosphere.

C. Rayleigh scattering which is proportional to $(1/\lambda^2)$

D. Most of the blue and other shorter wavelengths are not removed by scattering.

Answer: B



Watch Video Solution

Optical Instruments

1. When objects at different distances are seen by the eye, which of the following remains constant?

- A. the focal length of the eyes lens
- B. the objects distance from the eye lens
- C. the radii of curvature of the eye lens

D. the image distance from the eye lens

Answer: D



Watch Video Solution

2. An under-water swimmer cannot see very clearly even in absolutely clear water because of

A. absorption of light in water

B. scattering of light in water

C. reduction of speed of light in water

D. change in the focal length of eye lens

Answer: D



Watch Video Solution

3. The nearer point of hypermetropic eye is 40cm . The lens to be used for its correction should have the power

A. $+1.5D$

B. $-1.5D$

C. $+2.5D$

D. $+0.5D$

Answer: C



Watch Video Solution

4. When a telescope is in normal adjustment, the distance of the objective from the eyepiece is found to 100cm . If the magnifying

power of the telescope, at normal adjustment, is 24 focal lengths of the lenses are

- A. 96 cm, 4 cm
- B. 48 cm, 2 cm
- C. 50 cm, 50 cm
- D. 80 cm, 20 cm

Answer: A



Watch Video Solution

5. A compound microscope consists of an objective lens with focal length 1.0cm and eye piece of the focal length 2.0 cm and a tube 20cm from eye lens. Now final image is formed at the near point of eye, so find the magnifying power of microscope.

A. 300cm

B. 232cm

C. 290cm

D. 270cm

Answer: C



Watch Video Solution

6. In a compound microscope, the focal lengths of two lenses are 1.5cm and 6.25cm an object is placed at 2cm from objective and the final image is formed at 25cm from eye lens. The distance between the two lenses is

A. 6.00cm

B. 7.75cm

C. 9.25cm

D. 11.0cm

Answer: D



Watch Video Solution

7. A person with a normal near point (25cm) using a compound microscope with an objective of focal length 8.0mm and eye piece of focal length 2.5cm can bring an object placed 9.0cm from the objective in sharp

focus. What is the separation between the two lenses ? Calculate the magnifying power of the microscope ?

A. 9.47cm , 88

B. 3.36cm , 44

C. 6.00cm , 22

D. 4.79cm , 11

Answer: A



Watch Video Solution

8. The final image in an astronomical telescope adjustment, a straight black line of length L is drawn on the objective lens. The eyepiece forms a real image of this line. The length of this image is l . The magnification of the telescope is

- A. virtual and erect
- B. real and erect
- C. real and inverted
- D. virtual and inverted

Answer: D



Watch Video Solution

9. In an astronomical telescope in normal adjustment a straight black line of length L is drawn on inside part of objective lens. The eye piece forms a real image of this line. The length of this image is I . The magnification of the telescope is

A. $\frac{L}{l}$

B. $\frac{L}{l} + 1$

C. $\frac{L}{l} - 1$

D. $\frac{L + l}{L - l}$

Answer: A



Watch Video Solution

10. The focal length of the lenses of an astronomical telescope are 50 cm and 5 cm.

The length of the telescope when the image is

formed at the least distance of distinct vision
is

A. 45cm

B. 55cm

C. $\frac{275}{6}\text{cm}$

D. $\frac{325}{6}\text{cm}$

Answer: D



Watch Video Solution

11. A small telescope has an objective lens of focal length 144cm and an eye-piece of focal length 6.0cm . What is the magnifying power of the telescope ? What is the separation between the objective and the eye-piece ?

A. 0.75cm

B. 1.38cm

C. 1.0m

D. 1.5m

Answer: D



Watch Video Solution

12. An astronomical refractive telescope has an objective of focal length 20 m and an eyepiece of focal length 2 cm. Then

A. the magnification is 1000

B. the length of the telescope tube is 20.02

m

C. the image formed is inverted

D. all of these.

Answer: D



Watch Video Solution

13. A giant reflecting telescope at an observatory has an objective lens of focal length $15m$. If an eye piece lens of focal length $1cm$ is used, find the angular magnification of the telescope.

If this telescope is used to view the moon, what is the diameter of image of moon formed by objective lens ? The diameter of the moon

is $3.42 \times 10^6 m$ and radius of lunar orbit is $3.8 \times 10^8 m$.

A. 1000

B. 1500

C. 2000

D. 3000

Answer: B



Watch Video Solution

14. A small telescope has an objective lens of focal length 140 cm and an eyepiece of focal length 5.0 cm. what is the magnifying power of the telescope for viewing distant objects when

(a) the telescope is in normal adjustment (i.e, when the final image is at infinity),

(b) The final image is formed at the least distance of distinct vision (25 cm)

A. 33.6

B. 66.12

C. 22.6

D. 11.6

Answer: A



Watch Video Solution

15. A reflecting type telescope has a large concave spherical mirror of radius of curvature 80cm as objective. What is the magnifying power of telescope if eye piece used has a focal length of 1.6cm ?

A. 100

B. 50

C. 25

D. 5

Answer: C



Watch Video Solution

16. A giant telescope in an observatory has an objective of focal length 19 m and an eye-piece of focal length 1.0cm . In normal adjustment, the telescope is used to view the moon. What

is the diameter of the image of the moon formed by the objective? The diameter of the moon is $3.5 \times 10^6 m$. and the radius of the lunar orbit round the earth is $3.8 \times 10^8 m$.

A. $10cm$

B. $12.5cm$

C. $15cm$

D. $17.5cm$

Answer: D



Watch Video Solution

Miscellaneous

1. A ray of light travelling in the direction $\frac{1}{2}(\hat{i} + \sqrt{3}\hat{j})$ is incident on a plane mirror.

After reflection, it travels along the direction $\frac{1}{2}(\hat{i} - \sqrt{3}\hat{j})$. The angle of incidence is

A. 30°

B. 45°

C. 60°

D. 75°

Answer: A



Watch Video Solution

2. The number of capital letters such as *A, B, C, D.....* which are not laterally inverted by a plane mirror ?

A. 6

B. 7

C. 11

D. 13

Answer: C



Watch Video Solution

3. Two mirrors at an angle θ° produce 5 images of a point. The number of images produced when θ is decreased to $\theta^\circ - 30^\circ$ is

- A. 9
- B. 10
- C. 11
- D. 12

Answer: C



Watch Video Solution

4. A man stands symmetrically between two large plane mirrors fixed to two adjacent walls of a rectangular room. The number of images formed as

A. 4

B. 3

C. 2

D. 6

Answer: B



Watch Video Solution

5. Two plane mirrors M_1 and M_2 are inclined at angle as shown in Figure . A ray of light 1, which is parallel to M_1 , strike M_2 and after two reflections, ray 2 becomes parallel to M_2 .

Find the angle θ .

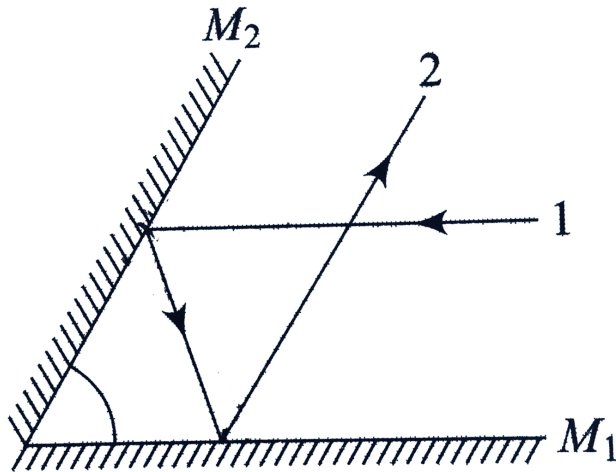

A. 0°

B. 30°

C. 45°

D. 60°

Answer: D



Watch Video Solution

6. Two plane mirrors are placed parallel to each other at a distance L apart. A point object O placed between them, at a distance $L/3$ from one mirror. Both mirrors form multiple image. The distance between any two images cannot be

A. $\frac{3L}{2}$

B. $\frac{2L}{3}$

C. $2L$

D. L

Answer: A



Watch Video Solution

7. Four identical mirrors are made to stand vertically to form a square arrangement as shown in a top view. A ray starts from the midpoint M of mirror AD and after two reflections reaches corner D . Then, angle θ

must be

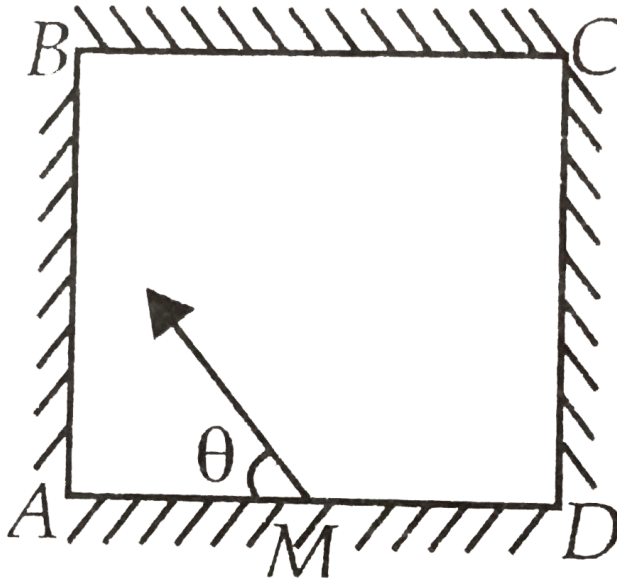

A. $\tan^{-1}(0.75)$

B. $\cot^{-1}(0.75)$

C. $\sin^{-1}(0.75)$

D. $\cos^{-1}(0.75)$

Answer: B



Watch Video Solution

8. Light incident normally on a plane mirror attached to a galvanometer coil reflects backward as shown in figure. A current in the coil produces a deflection of 3.5° of the mirror. The displacement of the reflected spot of light

on a screen placed 2.0m away is

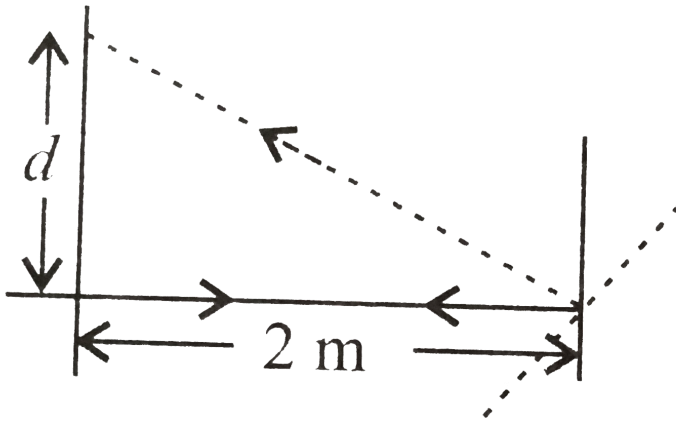

- A. 27.5m
- B. 48.9cm
- C. 24.5cm
- D. 12.2m

Answer: C



Watch Video Solution

9. A plane mirror is placed along the x -axis facing negative y -axis. The mirror is fixed, A point object is moving with $3\hat{i} + 4\hat{j}$ in front of the plane mirror. The relative velocity of image with respect to its object is

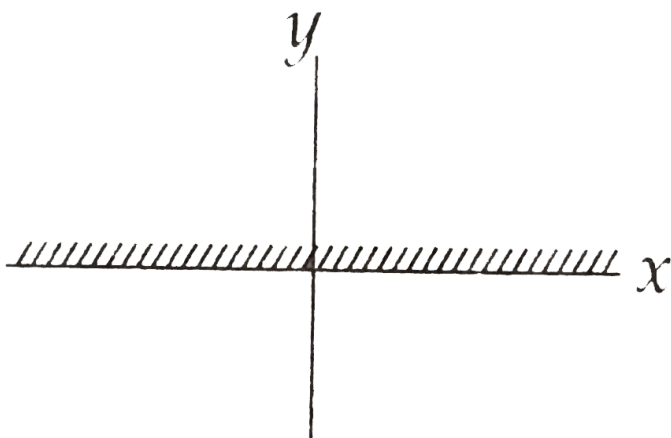

A. $-8\hat{j}$

B. $8\hat{j}$

C. $3\hat{i} - 4\hat{j}$

D. $-6\hat{i}$

Answer: A



Watch Video Solution

Higher Order Thinking Skills

1. A point object O is placed at a distance of 20 cm in front of an equiconvex lens (${}^a\mu_g = 1.5$) of focal length 10 cm. The lens is placed on a liquid of refractive index 2 as shown in figure. Image will be formed at a distance h from lens the value of h is



- A. 5 cm
- B. 10 cm
- C. 20 cm

D. 40 cm

Answer: D



Watch Video Solution

2. A ray of light travelling in a medium of refractive index μ is incident at an angle θ on a composite transparent plate consisting of 50 plates of R.I. $1.0\mu, 1.02\mu, 1.03\mu, \dots, 1.50\mu$. The ray emerges from the composite plate into a medium of refractive index 1.6μ at

angle 'x'. Then



A. $\sin x \left(\frac{1.01}{1.5} \right)^{50} \sin \theta$

B. $\sin x = \frac{5}{8} \sin \theta$

C. $\sin x = \frac{8}{5} \sin \theta$

D. $\sin x = \left(\frac{1.5}{1.01} \right)^{50} \sin \theta$

Answer: B



Watch Video Solution

3. A linear object of size 1.5cm is placed at 10cm from a lens of focal length 20cm . The optic centre of lens and the object are displaced are displaced a distance Δ . The magnification of the image formed is m . (Take optic centre of origin). The coordinates of image of A and B are (x_1, y_1) and (x_2, y_2) respectively then



A. $(x_1, y_1) = (-20\text{cm}, -2\text{cm})$

B. $(x_2, y_2) = (-20\text{cm}, 2\text{cm})$

C. $m = 5$

$$D. m = 4$$

Answer: B



Watch Video Solution

4. The size of the image of an object, which is at infinity, as formed by a convex lens of focal length 30 cm is 2 cm. If a concave lens of focal length 20 cm is placed between the convex lens and the image at a distance of 26 cm from

the convex lens, calculate the new size of the image.

A. 1.25cm

B. 2.5cm

C. 1.05cm

D. 2cm

Answer: B



Watch Video Solution

5. A bi-convex lens is formed with two thin plano-convex lenses as shown in the figure. Refractive index n of the first lens is 1.5 and that of the second lens is 1.2. Both the curved surfaces are of the same radius of curvature $R = 14\text{cm}$. For this bi-convex lens, for an object distance of 40cm, the image distance

will be

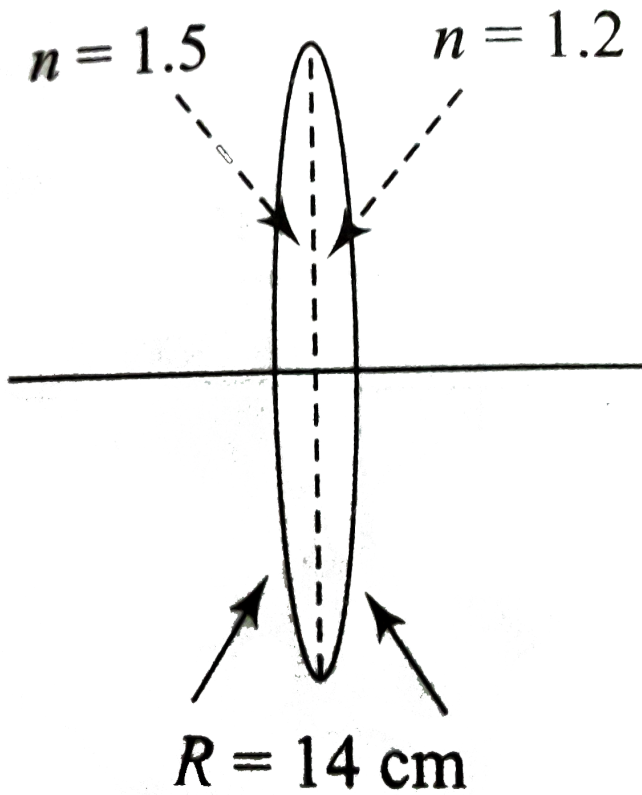

A. -280.0 cm

B. 40.0 cm

C. 21.5cm

D. 13.3cm

Answer: B



Watch Video Solution

6. A ray of light moving along the vector ($-i - 2j$) undergoes refraction at an interface two media, which is the x - z plane. The refractive index for $y > 0$ is 2 and below it is $\sqrt{5}/2$. the

unit vector along which the refracted ray moves is:

A. $\frac{-3\hat{i} - 5\hat{j}}{\sqrt{34}}$

B. $\frac{-(4\hat{i} - 5\hat{j})}{5}$

C. $\frac{-3\hat{i} - 4\hat{j}}{5}$

D. $\frac{-4\hat{i} + 3\hat{j}}{5}$

Answer: D



Watch Video Solution

7. A small bulb (assumed to be a point source) is placed at the bottom of a tank containing water to a depth of 80cm . Find out the area of the surface of water through which light from the bulb can emerge. Take the value of refractive index of water to be $4/3$.

A. 2.6m^2

B. 3.6m^2

C. 4.2m^2

D. 5.8m^2

Answer: A



Watch Video Solution

8. The mixture of a pure liquid and a solution in a long vertical column (i.e., horizontal dimensions \ll vertical dimensions) produces diffusion of solute particles and hence a refractive index gradient along the vertical dimension. A ray of light entering the column at right angles to the vertical is deviated from its original path. Find the

deviation in travelling a horizontal distance

$d < h$, the height of the column.



[View Text Solution](#)

Ncert Exemplar

1. A ray of light incident at an angle θ on a refracting face of a prism emerges from the other face normally. If the angle of the prism is 5° and the prism is made of a material of refractive index 1.5, the angle of incidence is.

A. 7.5°

B. 5°

C. 15°

D. 2.5°

Answer: A



Watch Video Solution

2. A short pulse of white light is incident from air to a glass slab at normal incidence. After

travelling through the slab, the first colour to emerge is.

A. blue

B. green

C. violet

D. red

Answer: D



Watch Video Solution

3. An object approaches a convergent lens from the left of the lens with a uniform speed 5 m/s and stops at the focus. The image.

A. moves away from the lens with an uniform speed 5 m s^{-1}

B. moves away from the lens with an uniform acceleration

C. moves away from the lens with a non-uniform acceleration

D. moves towards the lens with a non - uniform acceleration.

Answer: C



Watch Video Solution

4. A passenger in an aeroplane shall

A. never see a rainbow

B. may see a primary and a secondary rainbow is concentric arcs.

C. may see a primary and a secondary rainbow as concentric arcs.

D. shall never see a secondary rainbow.

Answer: B



Watch Video Solution

5. You are given four sources of light each one providing a light of a single colour-red, blue, green and yellow. Suppose the angle of refraction for a beam of yellow light

corresponding to a particular angle of incidence at the interface of two media is 90° .

Which of the following statements is correct if the source of yellow light is replaced with that of other lights without changing the angle of incidence ?

A. The beam of red light would undergo total internal reflection.

B. The beam of red light would bend toward normal while it gets refracted through the second medium.

C. The beam of blue light would undergo total internal reflection.

D. The beam of green light would bend away from the normal as it gets refracted through the second medium.

Answer: C



Watch Video Solution

6. The radius of curvature of the curved surface of a plano-convex lens is 20cm . If the refractive index of the material of the lens be 1.5, it will

A. act as a convex lens only for the objects that lie on its curved side.

B. act as a concave lens for the objects that lie on its curved side.

C. act as a convex lens irrespective of the side on which the object lies.

D. act as a concave lens irrespective of side on which the object lies.

Answer: C



Watch Video Solution

7. The phenomena involved in the reflected of radiowaves by ionosphere is similar to.

A. reflection of light by a plane mirror.

B. total internal reflection of light in air during a mirage.

C. dispersion of light by water molecules during the formation of a rainbow.

D. scattering of light by particles of air.

Answer: B



Watch Video Solution

8. The direction of ray of light incident on a concave mirror is shown by PQ while directions in which the ray would travel after reflection is shown by four rays marked 1, 2, 3 and 4, Fig. Which of the four rays correctly

shows the direction of reflected ray ?

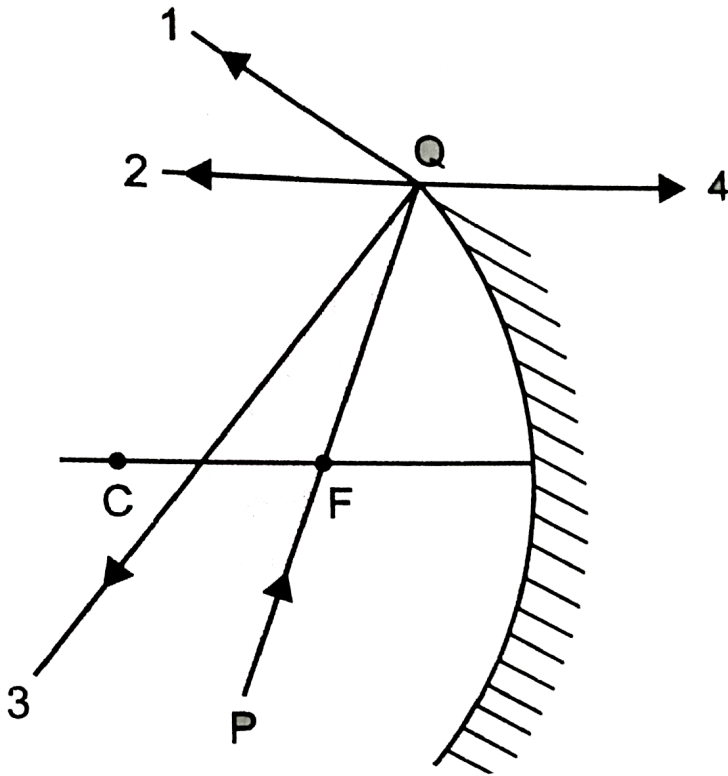

A. 1

B. 2

C. 3

D. 4

Answer: B



Watch Video Solution

9. The optical density of turpentine is higher than that of water, while its mass density is lower. Fig. shows a layer of turpentine floating over water in a container. For which one of the four rays incident on turpentine in Fig., the

path shows is correct ?

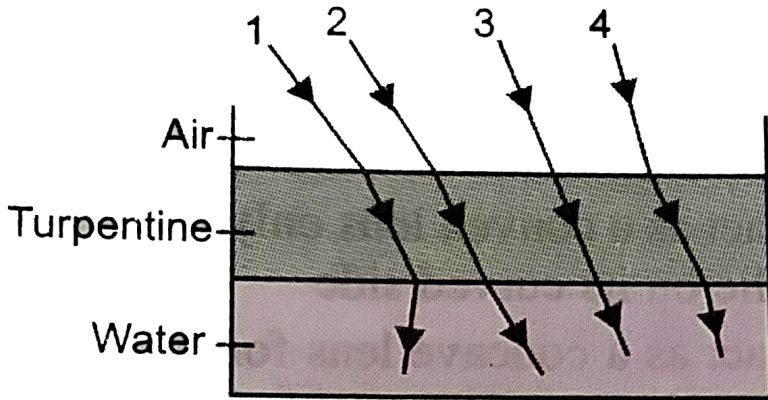

A. 1

B. 2

C. 3

D. 4

Answer: B





10. A car is moving with a constant speed of 60kmh^{-1} on a straight road. Looking at the rear view mirror, the driver finds that the car following him is at a distance of 100m and is approaching with a speed of 5kmh^{-1} . In order to keep track of the car in the rear, the driver begins to glance alternatively at the rear and side mirror of his car after every 2s till the other car overtakes. If the two cars were

maintaining their speeds, which of the following statement (s) is/are correct ?

A. The speed of the car in the rear is

$$65\text{kmh}^{-1}.$$

B. In the side mirror the car in the rear

would appear to approach with a speed

of 5kmh^{-1} to the driver of the leading

car.

C. In the rear view mirror the speed of the

approaching car would appear to

decrease as the distance between the cars decreases.

D. In the side mirror, the speed of the approaching car would appear to increase as the distance between the cars decreases.

Answer: D



Watch Video Solution

11. There are certain materials developed in laboratories which have a negative refractive index, Fig. A ray incident from air (medium 1) into such a medium (medium 2) shall follow a path given by

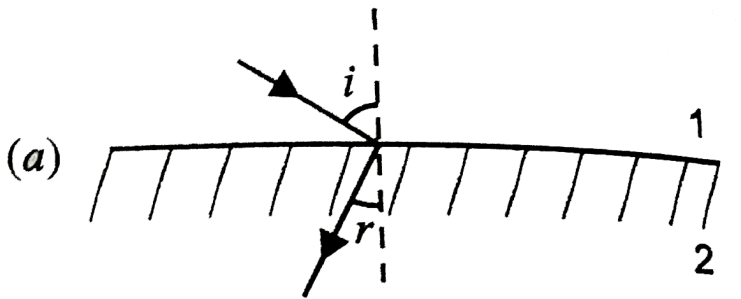

A. 

B. 

C. 

D. 

Answer: A



Watch Video Solution