



PHYSICS

BOOKS - PEARSON IIT JEE

FOUNDATION

KINEMATICS

Example

1. A horse is tied to a rope of length 5 m and the other end of the rope is tied to a pole.

Find the displacement and the distance travelled by the horse in the following cases.

When the horse makes half revolution along a circular path.



[Watch Video Solution](#)

2. A horse is tied to a rope of length 5 m and the other end of the rope is tied to a pole.

Find the displacement and the distance travelled by the horse in the following cases:

When it makes one full revolution.



[Watch Video Solution](#)

3. A horse is tied to a rope of length 5 m and the other end of the rope is tied to a pole. Find the displacement and the distance travelled by the horse in the following cases:

When it makes $\frac{3}{4}$ th of the revolution.



[Watch Video Solution](#)

4. A body moving along a straight path covers one-third of a distance with a velocity of 5

Kmph and the rest of the path with a velocity of 20 Kmph. Find the average velocity of the body.

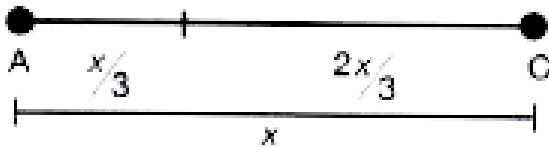

[Watch Video Solution](#)

5. A bird sitting on a tree top at a height of 5 m from the ground, picks up sticks lying on the ground to build a nest on the tree top. It

starts picking up the sticks at 7:00 a.m. and ends up at 7:10 a.m. During this interval it makes 5 trips up and down. Find the average speed and average velocity of the bird.



[Watch Video Solution](#)

6. A clock has its minut hand 14 cm long. At what speed and at what velocity does the tip of the minute hand move in a half an hour duration ?



[Watch Video Solution](#)

7. A car moves along a straight path with variable velocity as shown in the figure. When the car is at position A, its velocity is 10ms^{-1} and when it is at position B, its velocity is 20ms^{-1} . If the car takes 5 seconds of time to move from A to B, find the acceleration of the car.

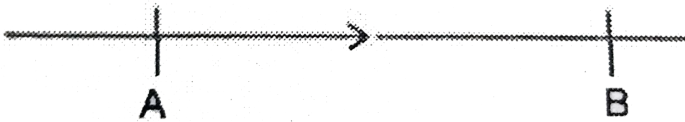

[Watch Video Solution](#)

8. The driver of a passenger train moving at a speed of 90kmh^{-1} observes a goods train at rest on the same track at a distance of 250 m and immediately applies the brakes. What should be the minimum retardation of the passenger train so as to avoid collision of the two trains?



[Watch Video Solution](#)

9. A train moving at a speed of 100 ms^{-1} comes to rest in 5 seconds. Find its retardation.



[Watch Video Solution](#)

10. A car accelerates uniformly at 4 m s^{-2} from rest. Find its velocity at the end of 5 seconds.



[Watch Video Solution](#)

Test Your Concepts Very Short Answer Type Questions

1. What are the different branches of mechanics?



[Watch Video Solution](#)

2. What is kinematics?



[Watch Video Solution](#)

3. How, do you represent a vector geometrically?



[Watch Video Solution](#)

4. What does the length of the line in geometrical representation of a vector signify?



[Watch Video Solution](#)

5. A body is first displaced by 5 m and then by 12 m in different direction. The minimum displacement it can have is _____ m



[Watch Video Solution](#)

6. Motion and rest are relative . How do you justify this?



[Watch Video Solution](#)

7. You are walking towards India Gate. Is India Gate at rest with respect with to you or in motion with respect to you?

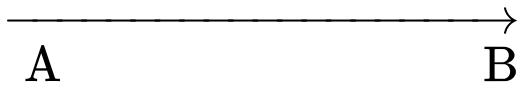

[Watch Video Solution](#)

8. A passanger, seated in a train is at rest with reference to _____



[Watch Video Solution](#)

9. Define scalar quantities and vector quantities.

Give some examples.



[Watch Video Solution](#)

10. The average value of gravity at sea level is

_____ ms^{-2} .



[Watch Video Solution](#)

11. A particle moved 5 m towards east and then moved 8 m towards west. What is the total distance travelled and the magnitude of displacement?



Watch Video Solution

12. Define distance, displacement, speed, velocity and acceleration.



Watch Video Solution

13. Speedometer of a vehicle measures its _____ speed.



[Watch Video Solution](#)

14. When does a particle motion have uniform speed?



[Watch Video Solution](#)

15. For a particle in a non-uniform accelerated circular motion



Watch Video Solution

16. What is instantaneous velocity?



Watch Video Solution

17. The ratio of the total distance travelled by a body to the total time taken is known as its



[Watch Video Solution](#)

18. Convert the following speeds into ms^{-1} .

18 $km\ h^{-1}$



[Watch Video Solution](#)

19. Convert the following speeds into ms^{-1} .

63 $km\ h^{-1}$



[Watch Video Solution](#)

20. Convert the following speeds into ms^{-1} .

99 km h⁻¹



Watch Video Solution

21. Convert the following speeds into ms^{-1} .

108 km h⁻¹



Watch Video Solution

22. Convert the following speeds into km h^{-1} .

$$2 \text{ m s}^{-1}$$



Watch Video Solution

23. Convert the following speeds into km h^{-1} .

$$10 \text{ m s}^{-1}$$



Watch Video Solution

24. Convert the following speeds into km h^{-1} .

$$12.5 \text{ m s}^{-1}$$



Watch Video Solution

25. Convert the following speeds into km h^{-1} .

$$15 \text{ m s}^{-1}$$



Watch Video Solution

26. $1 \text{ m s}^{-2} = \text{----- km h}^{-2}$



[Watch Video Solution](#)

27. A car attains a velocity of 20 m s^{-1} in 2.5 s. If initially it had been at rest, its acceleration must be _____.



[Watch Video Solution](#)

28. What is the acceleration of a body moving with uniform velocity ?



[Watch Video Solution](#)

29. Rate of decrease in the magnitude of velocity is also known as _____



Watch Video Solution

30. The displacement-time graph of a body is shown in the figure below. The part of the graph that represents the uniform motion of

the body is _____

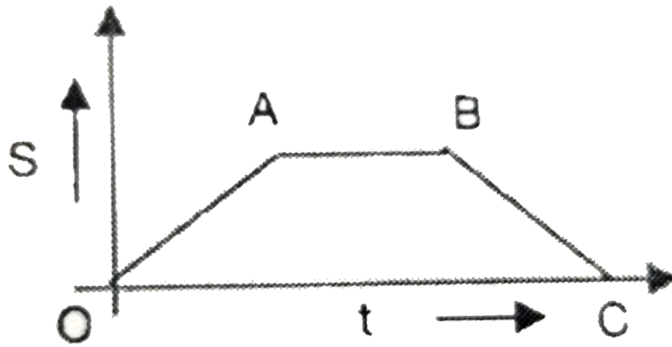

[▶ Watch Video Solution](#)

31. What are acceleration due to gravity

[▶ Watch Video Solution](#)

32. A bus moves by 8 m from its position of rest in 2 s, along a straight road. If it covers 10 m in the next second, it is moving with _____.



Watch Video Solution

33. What are the different types of graphs that can be drawn to represent the motion of a particle?



Watch Video Solution

34. Give the equations of motion of a particle undergoing retardation along a straight line.



Watch Video Solution

35. In a displacement versus time graph _____ is taken on the x-axis



Watch Video Solution

Test Your Concepts Short Answer Type Questions

1. Explain briefly what is mechanics and mention the different branches of mechanics.



[Watch Video Solution](#)

2. Compare and contrast scalars and vectors



[Watch Video Solution](#)

3. A race horse runs straight north and covers a distance of 12m then turns east and travels a

distance of 5m Draw the diagram showing the displacements and from the figure, calculate the net displacement of the horse.



[Watch Video Solution](#)

4. Redraw the following figure to scale and find out the distance and displacement of

particle moving along the path A-B-C-D

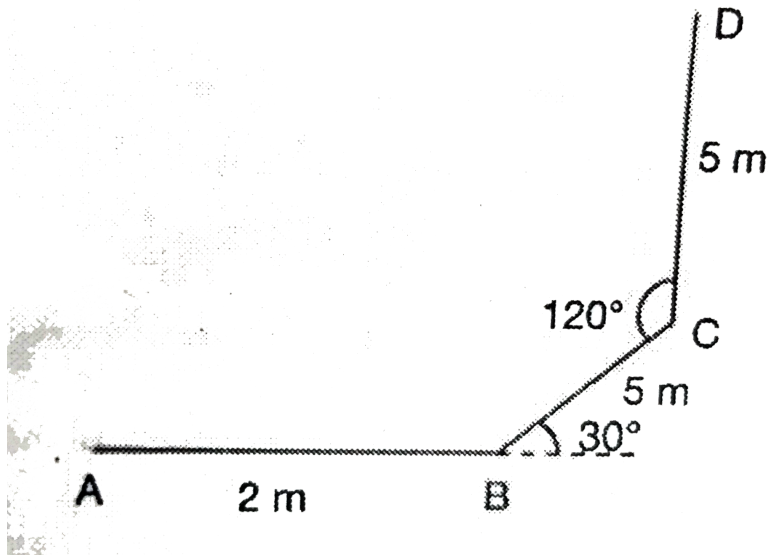

[Watch Video Solution](#)

5. Write three difference between distance and displacement.



[Watch Video Solution](#)

6. A crow picks up pebbles and puts them into a pot which is 10 m away from the pot. In doing so, it makes 5 trips within 80 seconds. What is the average speed of the crow?



[Watch Video Solution](#)

7. Differentiate between speed and velocity



[Watch Video Solution](#)

8. Write short notes on instantaneous speed and instantaneous velocity. Give examples.



[Watch Video Solution](#)

9. Explain , with an examples how a particle moving with uniform speed has variable velocity



[Watch Video Solution](#)

10. A pencil is tied to one end of a string of length 5 cm and the other is fixed to a nail. If the time taken to draw a half circle and a full circle, with the pencil is 2 and 4 seconds, respectively, find the speed and velocity pencil

(a) to draw half circle is drawn.

(b) when full circle is drawn



Watch Video Solution

11. Write short notes on acceleration and deceleration Give example.

 [Watch Video Solution](#)

12. A particle travel along a semi-circular path A-C-B as shown in the figure below. The radius of the semi-circular path is 7m.

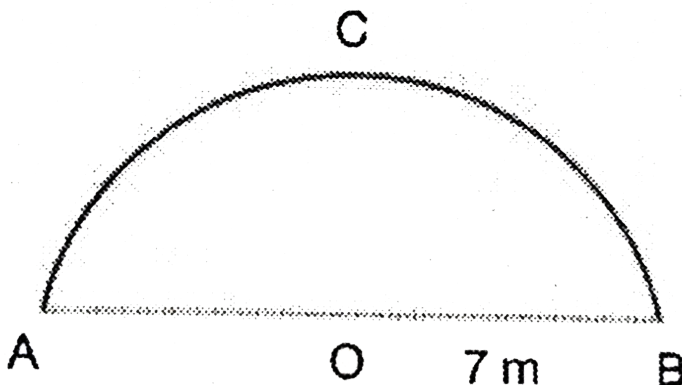

(a) Find the distance travelled by the particle

(b) Find the displacement (magnitude and direction)

(c) What would be these quantities if the particle completes the circle?



[Watch Video Solution](#)

13. If a particle is moving along a circle of radius 3 m with a constant speed 9 m/s , then it covers a quarter of the circle in time of



[Watch Video Solution](#)

Test Your Concepts Essay Type Questions

1. A partice takes 8 s to travel from A to B through P (see the figure given below) and another partice travelling through Q takes 7 s.

Find the speed and velocity of each particle.

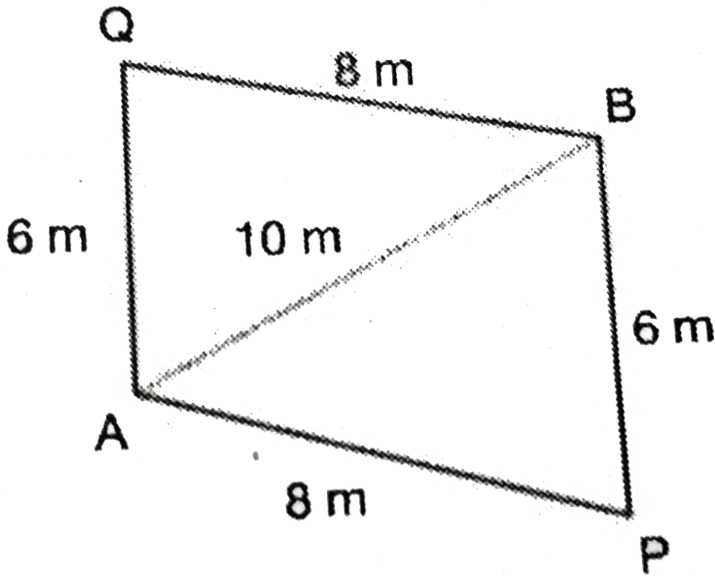

[Watch Video Solution](#)

2. A particle moving along a straight line has instantaneous velocities during the first 5 seconds as given below. Draw a velocity - time

graph

Time (t) in s	0	1	2	3	4	5
Velocity (v) in m s^{-1}	0	2.5	5	7.5	10	12.5



[Watch Video Solution](#)

3. Draw a displacement-time graph for the data given below with respect to a particle moving in a straight line

Time (t) in s	0	1	2	3	4
Displacement(s) in m	0	5	20	45	80



[Watch Video Solution](#)

4. For the previous question, the acceleration of the particle at any time t is :



[Watch Video Solution](#)

Concept Application Level 1 True Or False

1. Uniform speed is a vector quantity?



[Watch Video Solution](#)

2. For a body moving along a circular path the average velocity and average speed can never be equal



[Watch Video Solution](#)

3. Can a body at a constant speed and still have a varying velocity ?



[Watch Video Solution](#)

4. The magnitude of average velocity is equal to the average speed when a particle moves:-



[Watch Video Solution](#)

5. Velocity-time graph cannot be used to find instantaneous velocity



[Watch Video Solution](#)

6. Prove that average velocity of an object can never be greater than the average speed of an object over a given interval of time.



[Watch Video Solution](#)

7. The travel from a train from one station to another is an example of translatory motion



[Watch Video Solution](#)

1. velocity is taken on _____ axis In velocity-time graph.



[Watch Video Solution](#)

2. The ratio of the total displacement of a body to the total time taken is _____.



[Watch Video Solution](#)

3. The velocity-time graph of a body moving with uniform velocity is a straight line parallel to _____



[Watch Video Solution](#)

4. A body moving with constant speed has zero acceleration only when the particle is in _____ dimensional motion.



[Watch Video Solution](#)

5. The average speed of a bus in its whole journey when it travels a given distance between two places with a speed of 20 km hr^{-1} and returns back with a speed of 12 km hr^{-1} is _____.



[Watch Video Solution](#)

6. When a body has unequal displacements in equal interval, of time it is said to be moving with _____



[Watch Video Solution](#)

7. When a particle moves in a straight line from point A to point B the distance covered is _____ the magnitude of the displacement.



[Watch Video Solution](#)

Concept Application Level 1

1. Match the entries given in Column A with appropriate ones in Column B.

Column A		Column B	
A. Scalar quantity	()	a. One dimensional motion	
B. Vector quantity	()	b. Displacement in n th second	
C. s/t	()	c. $ut + \frac{1}{2}at^2$	
D. $v - u$	()	d. $\frac{(v+u)}{2}$	
E. S_n	()	e. Two dimensional motion	
F. Motion of a shell fired by a gun	()	f. $2as$	
G. Motion of a kite	()	g. Uniform velocity	
H. Motion of a car on a straight road	()	h. Three dimensional motion	
I. s	()	i. at	
J. $v^2 - u^2$	()	j. Average speed	



Watch Video Solution

Concept Application Level 1 Select The Correct Alternative

1. Two persons X and Y take 10 hours and 12 hours, respectively to travel from Bangalore to Hyderabad, then the

A. average velocity of X is equal to the average velocity of Y.

B. average velocity of X is less than that of Y.

C. average velocity of X is more than that of Y.

D. We cannot compare their velocities.

Answer: C



Watch Video Solution

2. A car starting from rest traveling along a straight path with uniform acceleration covers S_1 , S_2 and S_3 distances in the first, second and that seconds of its travel. Then, the ratio

of $\frac{(S_2 - S_1)}{(S_3 - S_2)}$ is _____

A. 3 : 5

B. 1 : 2

C. 1:3

D. 1:1

Answer: D



Watch Video Solution

3. The displacement-time graph of a body is shown in the figure below.

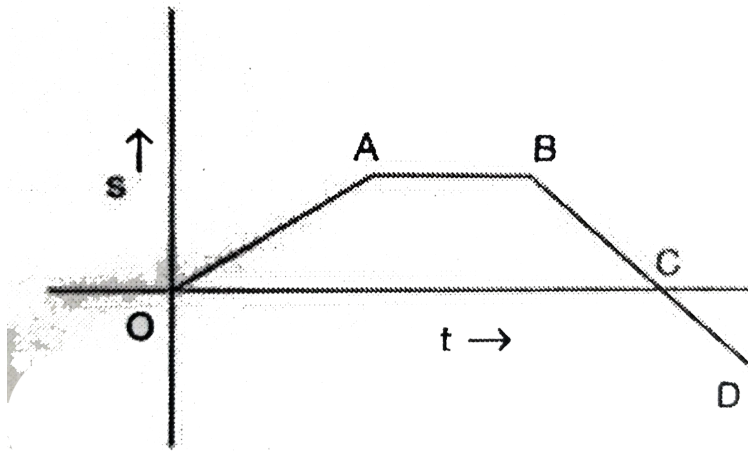

The part of the graph that represents the body at rest is

A. OA

B. AB

C. BC

D. CD

Answer: B



Watch Video Solution

4. A body is first displaced by 5 m and then by 12 m in different directions. The minimum displacement it can have is _____ m.

A. 0

B. 17

C. 7

D. 13

Answer: C



Watch Video Solution

5. A passanger, seated in a train is at rest with reference to _____

A. the bus.

B. a jeep moving in the opposite direction
to the bus.

C. the trees on the ground.

D. both (a) and (c).

Answer: D



Watch Video Solution

6. A body starting from rest along straight line is traveling with an acceleration of $6ms^{-1}$, then the distance traveled by it in the 3rd seconds is _____ m

A. 27

B. 18

C. 15

D. 21

Answer: C



Watch Video Solution

7. A body starts from rest and moves along a straight line path with uniform acceleration.

The ratio of velocities at $t = 1\text{ s}$ and $t = 2\text{ s}$ is

_____.

A. 2:1

B. 1:2

C. $1:\sqrt{2}$

D. $\sqrt{2}:1$

Answer: B



Watch Video Solution

8. A body undergoes a displacement of 3 m in the 1st second, 4 m in the 2nd second, 5 in the

3rd second and so on. The body is moving with
a/an

- A. uniform velocity
- B. uniform acceleration
- C. uniform deceleration
- D. None of these

Answer: B



Watch Video Solution

9. $45\text{kmh}^{-1} = \underline{\hspace{2cm}}\text{ms}^{-1}$

A. 162

B. 12.5

C. 2.5

D. 75

Answer: B



Watch Video Solution

10. A body moving from its initial position of rest along a straight line covers 1 m in 1s. It then covers 8 m in the next, then the body is moving with _____

A. uniform velocity

B. an acceleration of 2 m s^{-2} in the first second

C. average acceleration from $t = 1 \text{ s}$ to 3 s of 2 m s^{-2}

D. both (b) and (c)

Answer: D



Watch Video Solution

11. The ratio of the numerical values of the average velocity and average speed of a body is always.

- A. greater than
- B. less than or equal to
- C. greater than or equal to
- D. less than

Answer: B



Watch Video Solution

12. A bus travels one third of the distance with a speed of 12kmh^{-1} and the remaining distance with a speed of 20kmh^{-1} . The average speed of the bus is _____ kmh^{-1}

A. 14

B. 20

C. 12

D. 16.4

Answer: D



Watch Video Solution

13. The ratio of distances traveled by two bodies, A and B starting from rest moving along a straight line with equal accelerations is x , where $x \geq 1$, then

A. time taken by body A $>$ time taken by
body B.

B. time taken by body A $<$ time taken by
body B.

C. time taken by body A \geq time taken by
body B.

D. time taken by body A \leq time taken by
body B.

Answer: C



Watch Video Solution

14. When a body moves with uniform velocity then

- A. it has zero acceleration.
- B. it moves along a straight line path.
- C. average velocity = instantaneous velocity.
- D. All the above

Answer: D



Watch Video Solution

15. The velocity-time graph of a certain is shown in the following graph. The part of the graph that shows deceleration of the body is

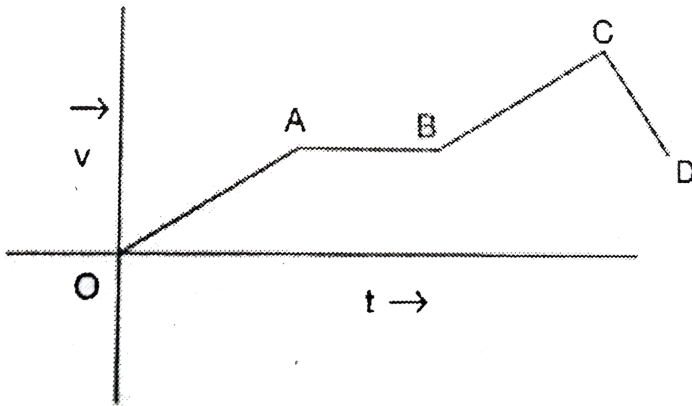

A. OA

B. AB

C. BC

D. CD

Answer: D

 [Watch Video Solution](#)

16. A body is moving along the curve, ABC as shown in the figure, and the initial and final positions are A and C, respectively. Displacement is the line joining

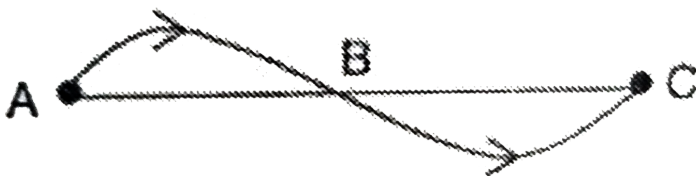

A. initial and final position of the body.

B. midpoint (B) and final position of the body.

C. midpoint (B) and initial position of the body.

D. Both (b) and (c)

Answer: A



Watch Video Solution

17. The speedometer of a car indicates

A. its instantaneous speed.

B. average speed.

C. average velocity

D. Both (a) and (c).

Answer: A



Watch Video Solution

18. A boy throw a ball vertically upwards and catches it after 2 seconds. Which of the following is true regarding the motion of the ball?

(a) The displacement is zero

(b) Magnitude of acceleration is constant

A. Only (i) is true.

B. Only (ii) is true.

C. Both (i) and (ii) are true.

D. Both (i) and (ii) are false.

Answer: C



Watch Video Solution

19. If a sports car at rest accelerates uniformly to a speed of 144 km h^{-1} in 5 s, it covers a distance of _____ m.

A. 100

B. 140

C. 60

D. 80

Answer: A



Watch Video Solution

20. Arrange the following steps in sequential order to show that the conduction of heat is different in different conductors

(a) take two identical rods one is copper and the other is iron

(b) The ends of the two rods are heated with the same spirit lamp

(c) fix some nails on the rods with the help of

wax at equal distances

(d) The nails near to the flame first from the copper rod and then from the iron rod.

A. B C E F A D G

B. A B C E G F D

C. A C B D F G E

D. B C A D F E G

Answer: D



Watch Video Solution

21. The driver of a car moving with a velocity of 54kmh^{-1} applies the brakes to decrease its velocity to 36kmh^{-1} . If the retardation produced by the brakes is 2.0ms^{-1} , arrange the following steps in sequential order to calculate the distance travelled by the car.

(a) Write down the required equation of motion as $v^2 - u^2 = 2as$ where v, u, a and s are final velocity, initial velocity, retardation and displacement,

(b) Write down the given data and convert all the values into the same system of units

(c) Get the value of 's' as $\frac{v^2 - u^2}{-2a}$

(d) Substitute the given values in the above equations

A. A B D C

B. B A C D

C. A D B C

D. A B C D

Answer: C



Watch Video Solution

22. Assrtion o (A) : A body may have velocity and displacement in the oppostie direction

Reason (R) : Velocity is distance travellled by the body in a unit time

A. A and R are correct and R is the correct explanation for A

B. A and R are correct but R is not the correct explanation for A

C. A is correct but R is incorrect.

D. Both A and R are incorrect.

Answer: C



Watch Video Solution

23. The $\vec{s} - t$ graph of a body is as shown in the figure. The time for which the body is in motion is _____ second

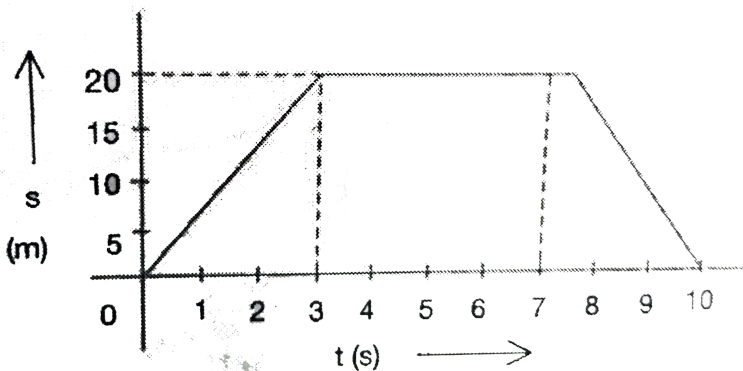

A. 2

B. 3

C. 6

D. 10

Answer: C



Watch Video Solution

24. The motion of a body is depicted graphically as shown in the figure. The average

speed of the body is _____ $m s^{-1}$.

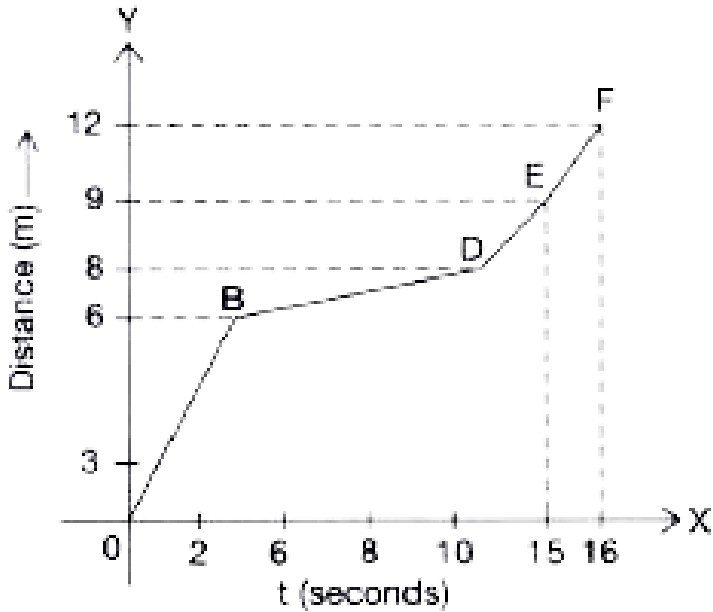

A. $3/4$

B. $9/8$

C. $4/3$

D. $8/9$

Answer: A



View Text Solution

25. An object moves the first half of the total distance with a speed of 2 m s^{-1} . If the average speed of the body is 3 m s^{-1} , the speed of the body when it travelled the remaining distance is _____ m s^{-1}

A. 3

B. 6

C. 4

D. 2

Answer: B



[View Text Solution](#)

26. An electric fan rotates 100 times in 50 s. If the length of its wing from its axis of rotation is 0.5 m, then the speed of particle at the edge of the wing is _____ m s^{-1} .

A. 2π

B. 0.5π

C. π

D. 2

Answer: A



View Text Solution

27. A person starts from a point and travels along a path PQRP as shown in the figure.

Then, the speed of the person is _____ ms^{-1} .

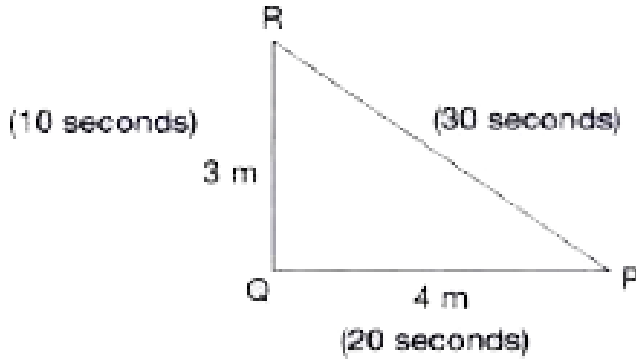

A. 0.2

B. 20

C. 12

D. 0.4

Answer: A



28. The ratio of the unit of acceleration and velocity gives the unit of the physical quantity _____.

- A. Time
- B. Frequency
- C. Amplitude
- D. Speed

Answer: B





[View Text Solution](#)

29. A bus moves with uniform velocity along a straight line path. If the average velocity of the bus is 80 km h^{-1} , then its instantaneous velocity at $t=0$ is _____ km h^{-1}

A. 70

B. 100

C. 80

D. zero

Answer: C



View Text Solution

30. A bus travels one-third of the distance with a speed of $12 \text{ km } h^{-1}$ and the remaining distance with a speed of $20 \text{ km } h^{-1}$. The average speed of the bus is nearly _____ $\text{km } h^{-1}$.

A. 14

B. 20

C. 12

D. 16

Answer: D



View Text Solution

Concept Application Level 2

1. In the following graphs, the velocity of linearly moving body is against its time of travel. Analyse each of the given graphs and

discuss the type of motion of the body

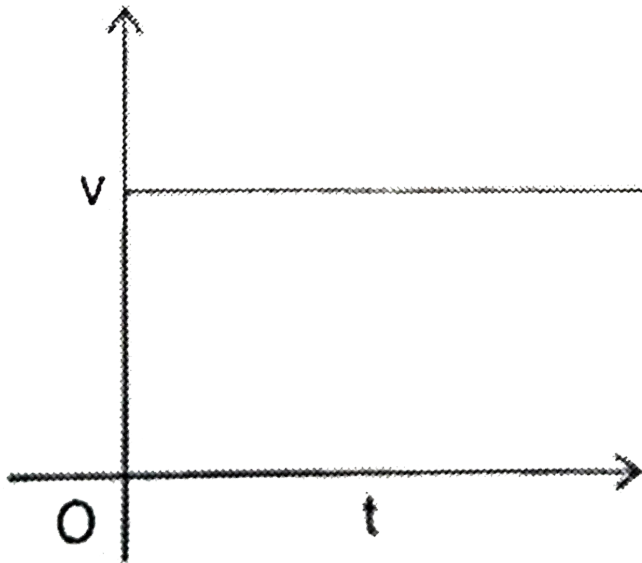

(ii)

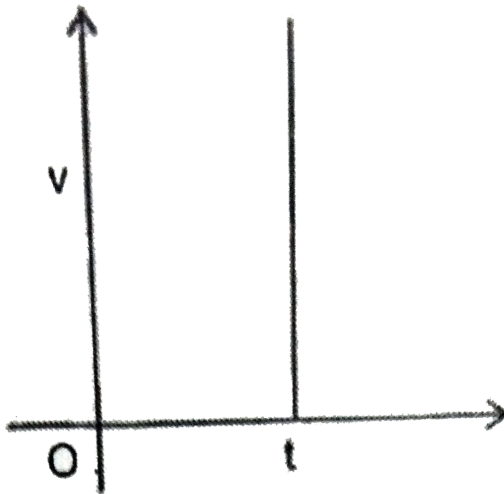

(iii)



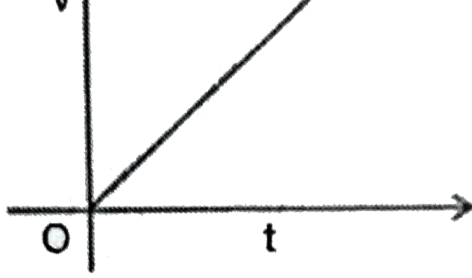

(iv)

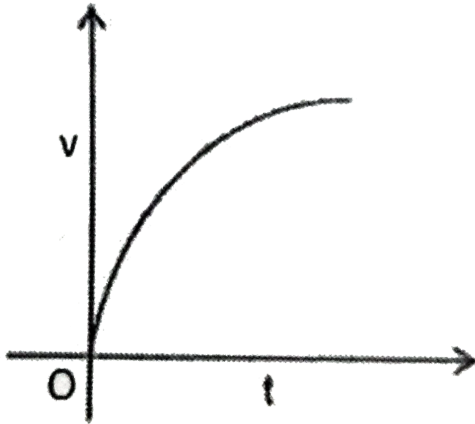

(v)

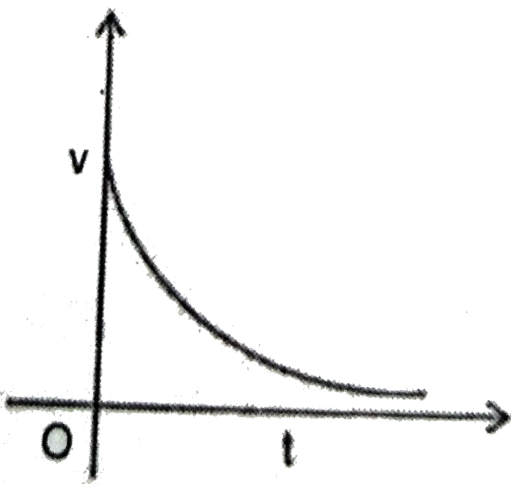

Watch Video Solution

2. In the following graphs, the velocity of linearly moving body is against its time of travel. Analyse each of the given graphs and discuss the type of motion of the body

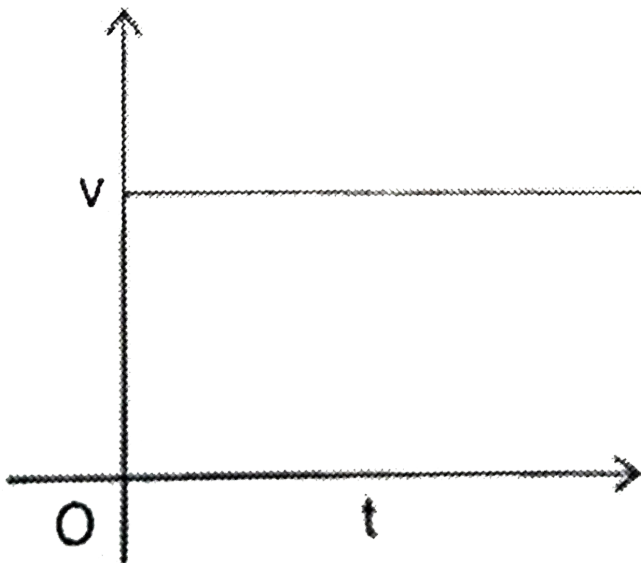

(ii)



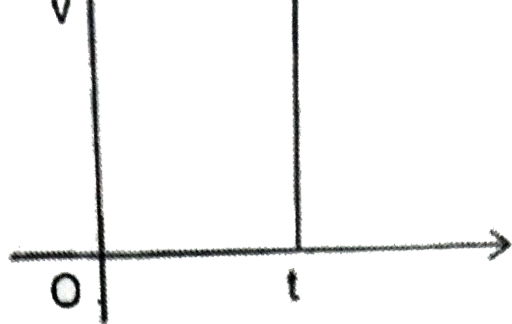

(iii)

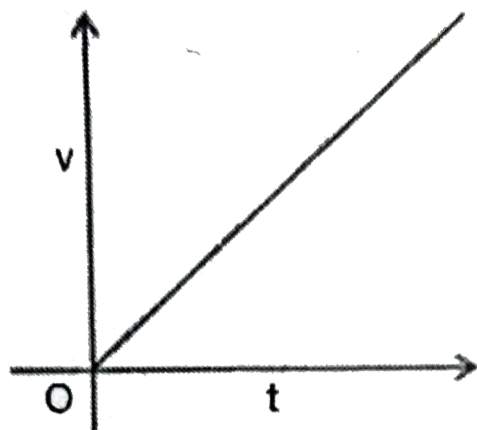

(iv)

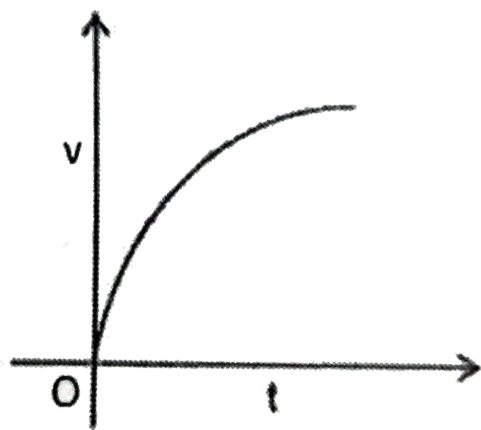

(v)



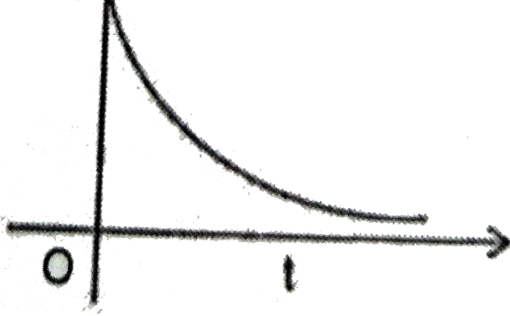

[Watch Video Solution](#)

3. In the following graphs, the velocity of linearly moving body is against its time of travel. Analyse each of the given graphs and discuss the type of motion of the body

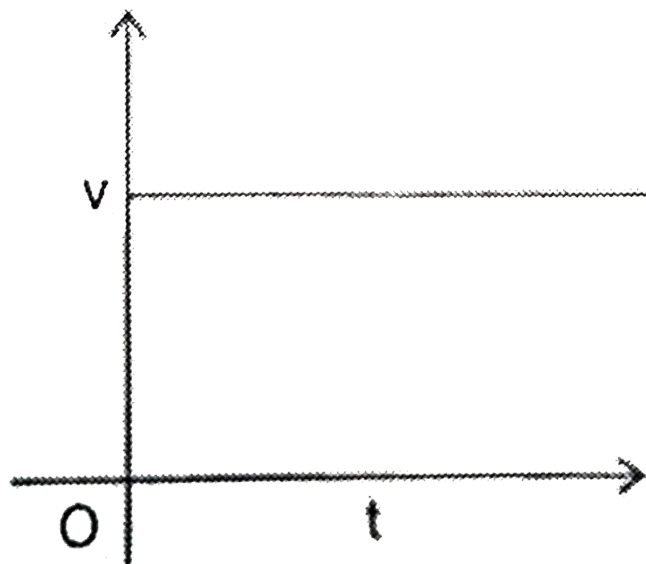

(ii)

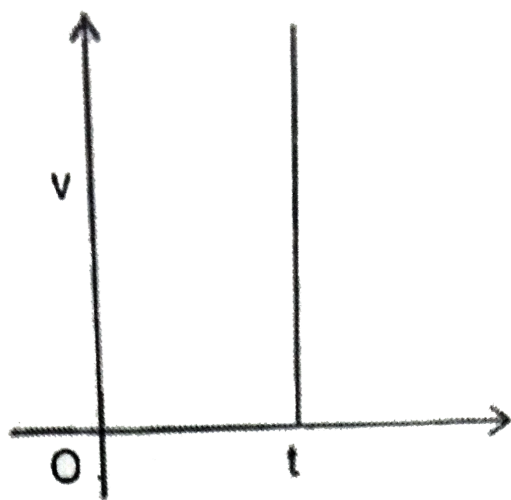

(iii)



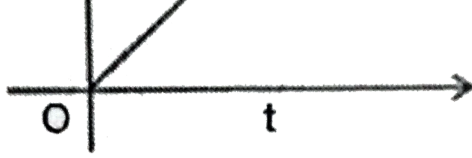

(iv)

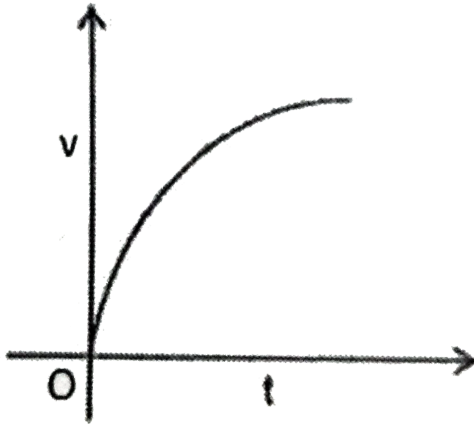

(v)

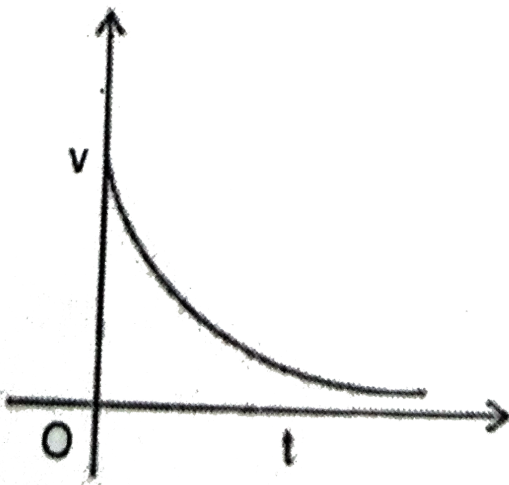

Watch Video Solution

4. In the following graphs, the velocity of linearly moving body is against its time of travel. Analyse each of the given graphs and discuss the type of motion of the body

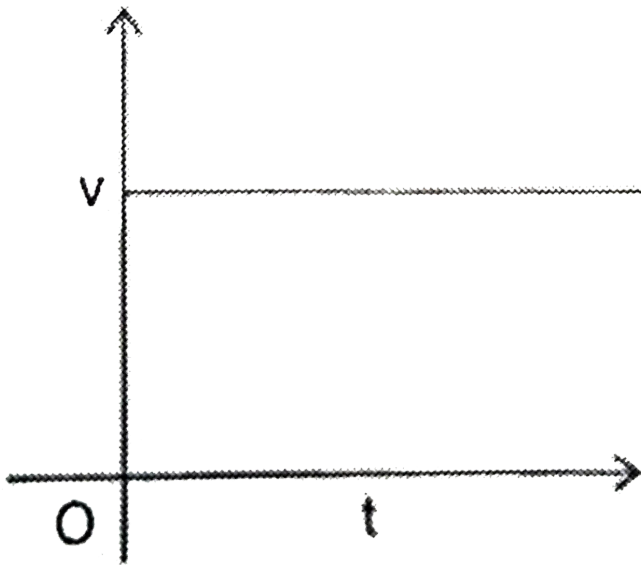

(ii)

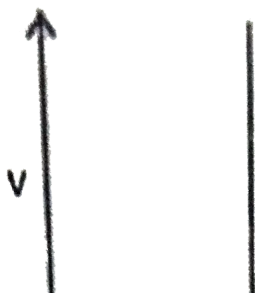



(iii)

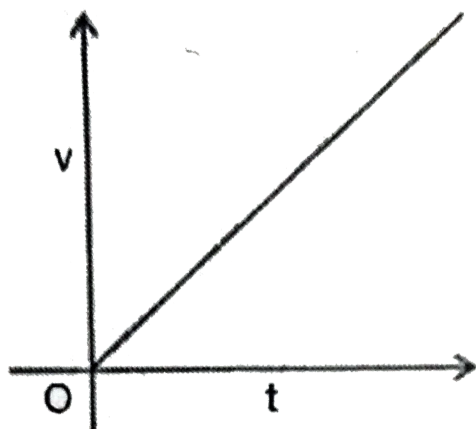

(iv)

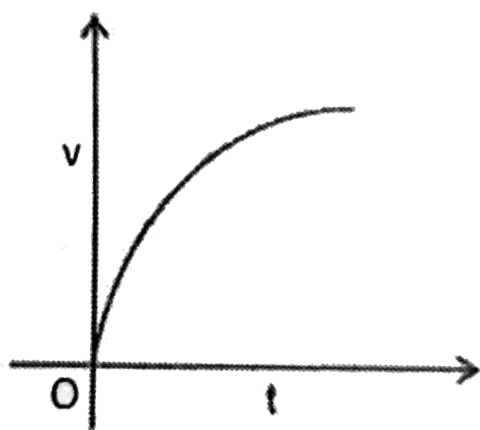

(v)

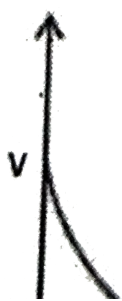



[Watch Video Solution](#)

5. In the following graphs, the velocity of linearly moving body is against its time of travel. Analyse each of the given graphs and discuss the type of motion of the body

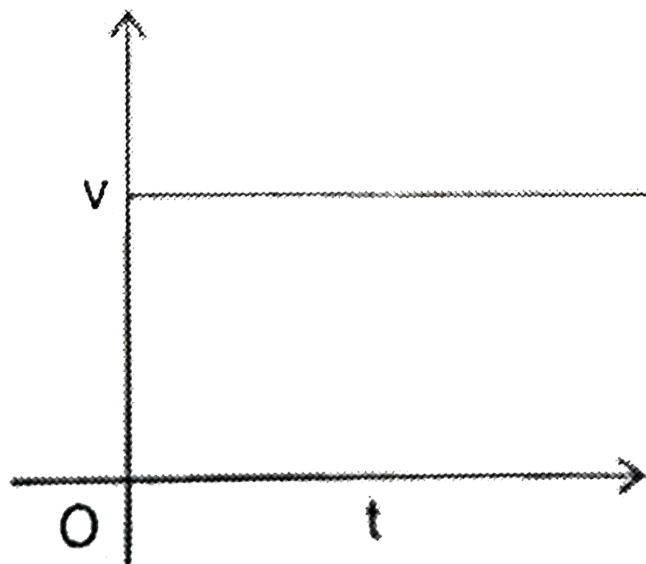

(ii)

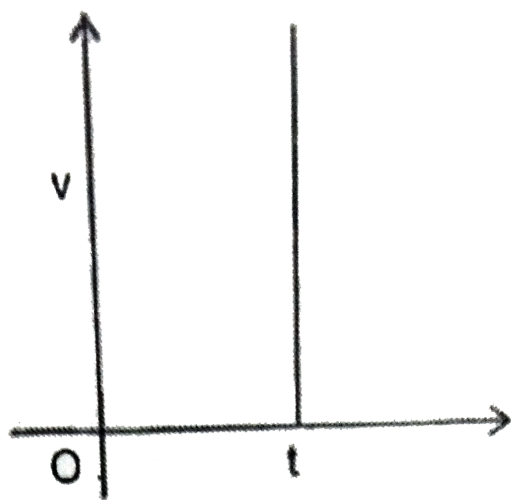

(iii)



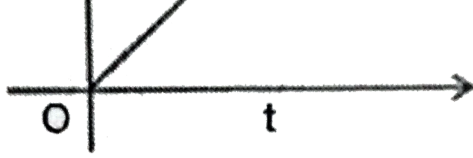

(iv)

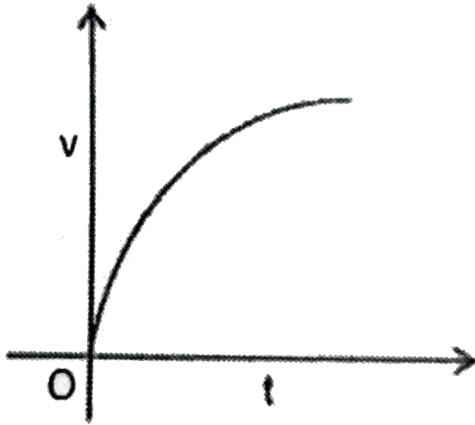

(v)

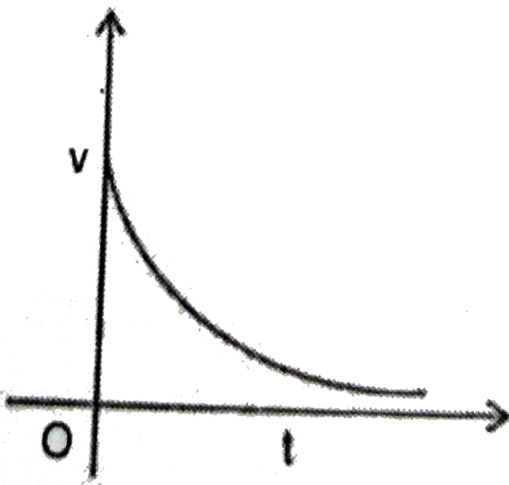

Watch Video Solution

6. A bus moving along a straight highway with a speed of 72 km h^{-1} is brought to rest within a distance of 50 m. How long does it take for the bus to stop?



[Watch Video Solution](#)

7. A train of certain length traveling with a uniform speed of 36 km h^{-1} crosses a bridge of 600 m in 80 s. Find the length of the train.



[Watch Video Solution](#)

8. The length of a minute hand of clock is 3 cm. Find the average velocity of the tip of the minute hand when it moves during a time interval from 4:00 p.m. to 4:15 p.m.



Watch Video Solution

9. Give examples of variable velocity, when the magnitude is constant and the direction is changing.



View Text Solution

10. Give examples of variable velocity, when the magnitude is changing and the direction remains the same.



View Text Solution

11. Give examples of variable velocity, when

(a) the magnitude is constant and the direction is changing

(b) the magnitude is changing and the

direction remains the same

(c) both the magnitude and direction are changing



[Watch Video Solution](#)

12. The distance between two places A and B is 180 km by road and 120 km by air. An aeroplane takes 20 min to go from A to B whereas a deluxe bus starting at A takes 5h to reach B. Find the average speed and

average velocity by both means of transport)

(Ignore the vertical ascent of aeroplane)



[Watch Video Solution](#)

13. A car starting from rest and moving with uniform acceleration on a straight road travels for sometime such that the paths described by it in the last second and the penultimate second of its motion are in the ratio 4:3 respectively . Calculate the total time traveled by the body



[Watch Video Solution](#)

14. On a 60 km stretch of road a cyclist travels first 20 km at a uniform speed of 20 km h^{-1} . How fast must he travel the remaining distance so that his average speed is 10 km h^{-1} for the entire trip.



[View Text Solution](#)

15. A car starting from rest and moving along a straight path with uniform acceleration covers

distances p and q in the first two successive equal intervals of time. Find the ratio of p to q .



[Watch Video Solution](#)

16. A bus starts from rest with an acceleration of 5ms^{-2} . A man who is on a motorcycle, 24 m behind the bus, overtakes the bus in 2s. If the motorcyclist moves with uniform velocity, find his velocity



[Watch Video Solution](#)

17. The dimensions (measurements) of a hall are 12m, 4 m and 3, respectively. An ant starts at one corner of the hall, travels only along the adgees and reaches a diagonally opposite, corner, taking the shortest possible route. Find the distance travelled by the at t and its magnitude of displacement .



Watch Video Solution

18. A car takes 25 s to stop after the application of brakes. What is the distance

traveled by the car if the brakes produce a uniform retardation of 0.4 m s^{-2} ?



[View Text Solution](#)

19. A bus starts moving with uniform acceleration from its position of rest. It moves 48 m in 4 s. On applying the brakes, it stops after covering 24 m. Find the deceleration of the bus.



[View Text Solution](#)

20. A bus traveling along a straight highway covers one third of the total distance between two places with a velocity 20kmh^{-1} . The remaining part of the distance was covered with a velocity of 30kmh^{-1} for the first half of the remaining time and with velocity 50kmh^{-1} for the next half on the time. Find the average velocity of the bus for its whole journey.



[Watch Video Solution](#)

21. A particle starts from rest and moves with a constant acceleration along a straight path to attain 64 m s^{-1} in t s. If at $t = (t + 3)$ s the speed is 76 m s^{-1} , then find the acceleration of the particle and 't'.



[View Text Solution](#)

Concept Application Level 3 Understanding
Based Questions

1. A car accelerates uniformly from rest. If the reading on the speedometer after 5 s is 72 km h^{-1} , determine the acceleration of the car.



[View Text Solution](#)

2. A person starts from point A and reaches point C which is the midpoint of BD. If he takes four seconds time, then determine

(a) the average speed

(b) the average velocity.

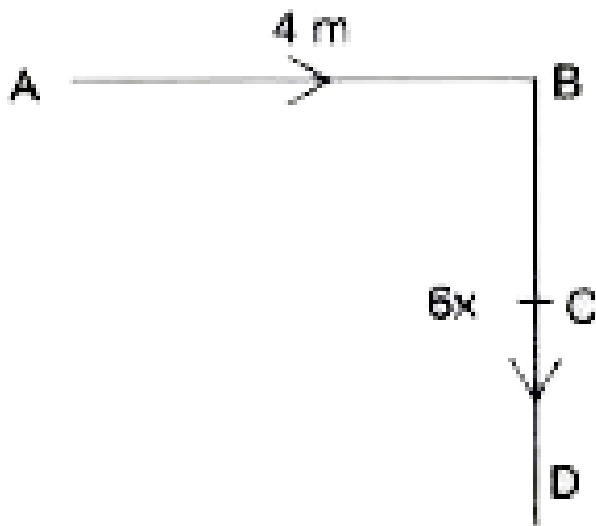

 [View Text Solution](#)

3. In the figure shown, explain the difference

between \overrightarrow{DE} and \overrightarrow{ED} .

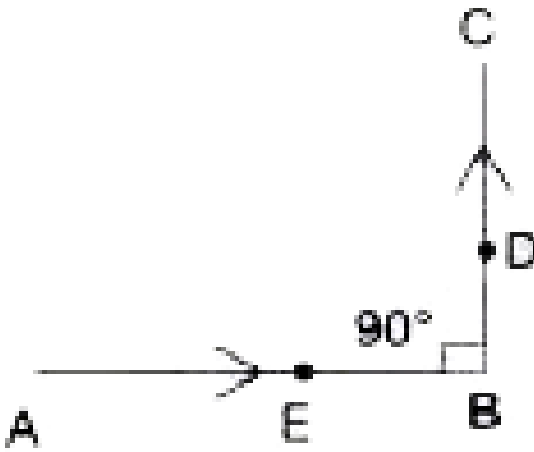

[View Text Solution](#)

4. A police man is running with a uniform speed of 5kmh^{-1} and a thief is running with a uniform speed of 2kmh^{-1} . Is it possible to find

whether the policeman can catch the thief?

Explain

 [Watch Video Solution](#)

5. An object moves along the path ABC as shown in the figure. Determine the displacement.



 [View Text Solution](#)

6. A policeman is running with a uniform velocity of 5kmh^{-1} towards east and a thief is running with a uniform velocity of 2kmh^{-1} towards east. Is it possible for the policeman to catch the thief? Explain



[Watch Video Solution](#)

7. A thief is running away on a straight road in a moving with a speed of 9ms^{-1} . A policeman chases him on a motor cycle moving at a

speed of 10ms^{-1} . If the instantaneous separation of the jeep from the motor cycle is 100m , how long will it take for the policeman to catch the thief ?.



[Watch Video Solution](#)

8. A bike starting from rest picks up a velocity of 72 km h^{-1} over a distance of 40 m . Calculate its acceleration.



[View Text Solution](#)

9. A pencil is tied to one end of a string of length 5 cm and the other is fixed to a nail. If the time taken to draw a half circle and a full circle, with the pencil is 2 and 4 seconds, respectively, find the speed and velocity pencil

(a) to draw half circle is drawn.

(b) when full circle is drawn



Watch Video Solution

10. A partical takes 8 s a to travel from A to B through P (sec the figure given below) and

another particle travelling through Q takes 7s.

Find the speed and velocity of each particle.

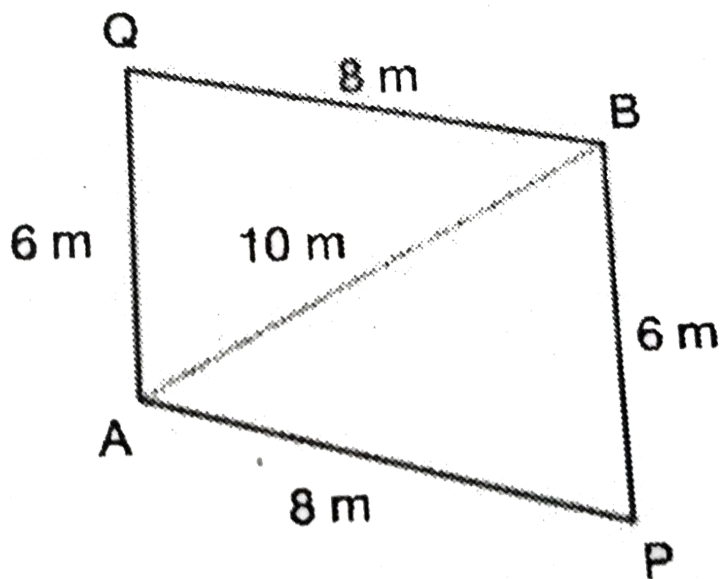

[Watch Video Solution](#)

Concept Application Level 3

1. A Bullet Train in Japan starting from rest accelerates uniformly at 0.5ms^{-2} for 2 minutes. It then maintains uniform speed for 20 minutes and then retards uniformly at the rate of 0.25ms^{-1} and comes to rest. Calculate the average speed of the train



[Watch Video Solution](#)

2. A stone is thrown vertically upward. The stone crosses a particular height twice at time t_1

and t_2 . Find the initial speed of the stone.



[Watch Video Solution](#)

3. Find the initial velocity and acceleration of a body if the distance traveled by that body in n th second is $(5.69 + 0.008n)$ m



[Watch Video Solution](#)

Concept Application Level 3 Application Based Questions

1. A race horse runs straight north and covers a distance of 12m then turns east and travels a distance of 5m Draw the diagram showing the displacements and from the figure, calculate the net displacement of the horse.



[Watch Video Solution](#)

2. A crow picks up pebbles and puts them into a pot which is 10 m away from the pot. In doing so, it makes 5 trips within 80 seconds. What is the average speed of the crow?



[Watch Video Solution](#)

3. A boy kicks a football horizontally from the roof of a building of height 10m, . If the line joining the initial position of the football and the point where it hits the ground make an angle of 45° with the ground, then find the displacement of the football



[Watch Video Solution](#)

4. A rod of length 2m starts to roll on a horizontal surface as shown in figure. At the same time an ant starts from one end of the rod to other and when the rod rolls through a distance 10m the ant reaches the other end (B). Calculate the distance and displacement of the ant

(a) with respect to the rod

(b) with respect to the ground.

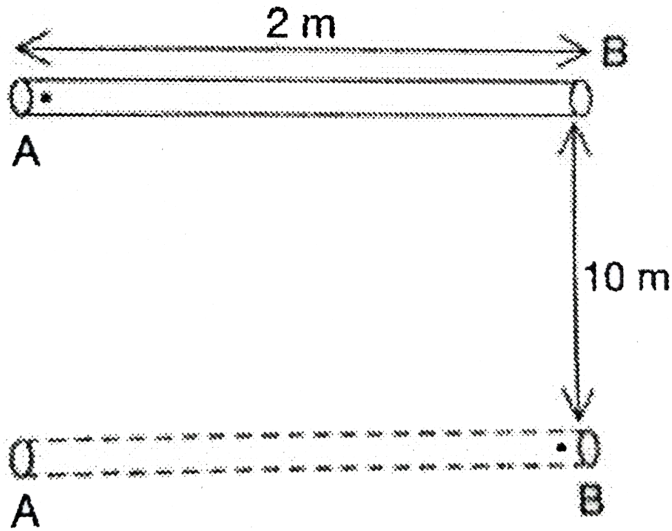

[Watch Video Solution](#)

5. A bird sitting on a tree top at a height of 5 m from the ground, picks up sticks lying on the ground to build a nest on the tree top. It

starts picking up the sticks at 7:00 a.m. and ends up at 7:10 a.m. During this interval it makes 5 trips up and down. Find the average speed and average velocity of the bird.



Watch Video Solution