



# MATHS

## BOOKS - EDUCART PUBLICATION

### SAMPLE PAPER 2019

#### Section A

1. Write the discriminant of the quadratic equation

$$(x + 5)^2 = 2(5x - 3).$$



[Watch Video Solution](#)

2. Find after how many places of decimal the decimal form of the number  $\frac{27}{2^3 \cdot 5^4 \cdot 3^2}$  will terminate.



[Watch Video Solution](#)

3. Express 429 as a product of its prime factors.



[Watch Video Solution](#)

4. Find the sum of first 10 multiples of 6.



[Watch Video Solution](#)

5. Find the value (s) of  $x$  , if the distance between the points  $A(0,0)$  and  $B(x,-4)$  is 5 units.



[Watch Video Solution](#)

6. Two concentric circles of radii  $a$  and  $b$  ( $a > b$ ) are given. Find the length of the chord of the larger circle which touches the smaller circle.



[Watch Video Solution](#)

7. In Figure ,PS=3cm, QS=4 cm,

$\angle PRQ = \theta$ ,  $\angle PSQ = 90^\circ$ ,  $PQ \perp RQ$  and  $RQ = 9$  cm . Evaluate  $\tan \theta$ .

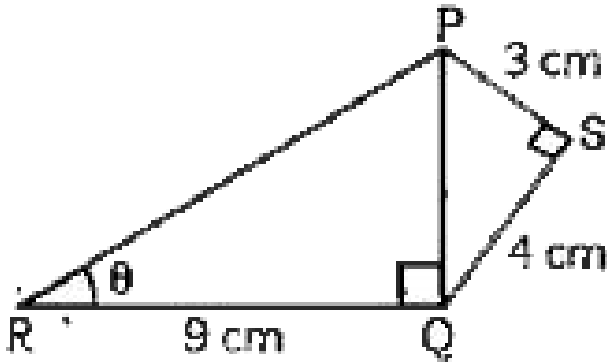

[Watch Video Solution](#)

8. If  $\tan \alpha = \frac{5}{12}$ , find the value of  $\sec \alpha$ .



[Watch Video Solution](#)

## Section B

1. Points A (3,1), B(5,1), C(a,b) and D (4,3) are vertices of a parallelogram ABCD .Find the values of a and b .



[Watch Video Solution](#)

2. Points P and Q trisect the line segment joining the points A (-2,0) and B(0,8) such that ,P is near to A . Find the coordinates of points P and Q.



[Watch Video Solution](#)

3. Solve the pair of linear equations.  $y - 4x = 1$   
and  $6x - 5y = 9$



[Watch Video Solution](#)

4. If  $HCF$  of 65 and 117 is expressible in the form  $65m - 117$ , then the value of  $m$  is



[Watch Video Solution](#)

5. On a morning walk ,three persons step out together and their steps measure 30 cm , 36 cm

and 40 cm respectively .What is the minimum distance each should walk so that each can cover the same distance in complete steps?



[Watch Video Solution](#)

6. A die is thrown once .Find the probability of getting

(i) a composite number , (ii) a prime number.



[Watch Video Solution](#)

7. Using completing the square method ,show that the equation  $x^2 - 8x + 18 = 0$  has no solution.



[Watch Video Solution](#)

8. Cards numbered 7 to 40 were put in a box . Poonam selects a card at random .What is the probability that Poonam selects a card which is a multiple of 7 ?



[Watch Video Solution](#)



1. The perpendicular from A on side BC of a  $\Delta ABC$  meets BC at D such that  $DB = 3CD$ . Prove that  $2AB^2 = 2AC^2 + BC^2$ .



[Watch Video Solution](#)

2. If AD and PM are medians of triangles ABC and PQR, respectively where  $\Delta ABC \sim \Delta PQR$ , prove that

$$\frac{AB}{PQ} = \frac{AD}{PM}$$



[Watch Video Solution](#)

3. Check whether  $g(x)$  is a factor of  $p(x)$  by dividing polynomial  $p(x)$  by polynomial  $g(x)$ , where

$$p(x) = x^5 - 4x^3 + x^2 + 3x + 1, g(x) = x^3 - 3x + 1$$

.



[Watch Video Solution](#)

4. Find the area of the triangle formed by joining the mid -points of the sides of the triangle ABC ,whose vertices are  $A(0,-1),B(2,1)$ and $C(0,3)$ .



[Watch Video Solution](#)

5. Find the values of  $x$  and  $y$  which satisfy both the equations:

$$x - y = 11 \text{ and } 4x + y = 14.$$



[Watch Video Solution](#)

6. Prove that  $\sqrt{3}$  is an irrational number.



[Watch Video Solution](#)

7. Find the greatest number which divides 1251, 9377 and 15628 leaving remainders 1, 2 and 3 respectively.



[Watch Video Solution](#)

8. (i) A, B and C are interior angles of a triangle

ABC. Show that  $\sin\left(\frac{B + C}{2}\right) = \cos\left(\frac{A}{2}\right)$ .

(ii) If  $\angle A = 90^\circ$ , then find the value of

$\tan\left(\frac{B + C}{2}\right)$ .



[Watch Video Solution](#)

9. If  $\tan(A + B) = \sqrt{3}$  and

$\tan(A - B) = \frac{1}{\sqrt{3}}$ ,  $0^\circ < A + B \leq 90^\circ$ ,  $A > B$ ,

then find the value of A and B.



[Watch Video Solution](#)

10.  $PQ$  is a chord of length 8 cm of a circle of radius 5 cm. The tangents at  $P$  and  $Q$  intersect at a point  $T$ . Find the length  $TP$ .



[Watch Video Solution](#)

11. Prove that opposite sides of a quadrilateral circumscribing a circle subtend supplementary angles at the centre of the circle.



[Watch Video Solution](#)

**12.** Water in a canal, 6 m wide and 1.5 m deep, is flowing with a speed of 10 km/h. How much area will it irrigate in 30 minutes, if 8 cm of standing water is needed?



**Watch Video Solution**

**13.** A class teacher has the following absentee record of 40 students of a class for the whole term. Find the mean number of days a student was absent.



**Watch Video Solution**

**14.** A car has two wipers which do not overlap. Each wiper has a blade of length 21 cm, sweeping through an angle of  $120^\circ$ . Find the total area cleaned at each sweep of the blades.



**Watch Video Solution**

## Section D

**1.** A pole has to be erected at a point on the boundary of a circular park of diameter 13 metres in such a way that the differences of its distances

from two diametrically opposite fixed gates A and B on the boundary is 7 metres. Is it possible t



[Watch Video Solution](#)

2. If  $m$  times the  $m^{\text{th}}$  term of an Arithmetic Progression is equal to  $n$  times its  $n^{\text{th}}$  term and  $m \neq n$ , show that the  $(m + n)^{\text{th}}$  term of the AP is zero .



[Watch Video Solution](#)



3. The sum of the first three numbers in an Arithmetic Progression is 18. If the product of the first and the third term is 5 times the common difference, find the three numbers.



[Watch Video Solution](#)

4. Draw a triangle  $ABC$  with side  $BC = 6$  cm,  $AB = 5$  cm and  $\angle ABC = 60^\circ$ . Then construct a triangle whose sides are  $\frac{3}{4}$  of the corresponding sides of the triangle  $ABC$ .



[Watch Video Solution](#)

5. The decorative block is made of two solids a cube and a hemisphere. The base of the block is a cube with edge 5 cm, and the hemisphere fixed on the top has a diameter of 4.2 cm. Find the total surface area of the block.



[Watch Video Solution](#)

6. In Figure a decorative block is shown which is made of two solids , a cube and a hemisphere .The base of the block is cube with edge 6 cm and the hemisphere fixed on the top has a diameter of 4.2 cm .Find :

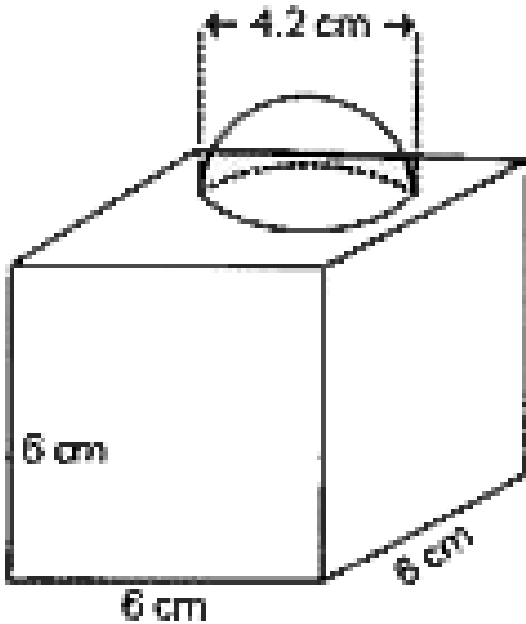

the volume of the block formed`



[Watch Video Solution](#)

7. A bucket is in form of a frustum of a cone with a capacity of  $12308.8\text{cm}^3$  of water. The radii of the

top and bottom circular ends are 20 cm and 12 cm respectively. Find the height of the bucket and the area of the metal sheet used in its making. [ Use  $\pi = 3.14$ . ]



[Watch Video Solution](#)

**8. Theorem 6.1 :** If a line is drawn parallel to one side of a triangle to intersect the other two sides in distinct points, the other two sides are divided in the same ratio.



[Watch Video Solution](#)

9. Prove that in a right angle triangle, the square of the hypotenuse is equal to the sum of the squares of the other two sides.



[Watch Video Solution](#)

10. If  $1 + \sin^2 \beta = 3 \sin \beta \cdot \cos \beta$ , then prove that  $\tan \alpha = 1$  or  $\tan \alpha = \frac{1}{2}$ .



[Watch Video Solution](#)

11. For what values of  $x$  does the equation hold true?

$$2^{4x^2 + 5x - 2} = 16$$



[Watch Video Solution](#)

**12.** The shadow of a tower standing on a level ground is found to be 40 m longer when the Sun's altitude is  $30^\circ$  than when it is  $60^\circ$ . Find the height of the tower.



[Watch Video Solution](#)