



# MATHS

## BOOKS - AGRAWAL PUBLICATION

### Sample paper 9

#### Exercise

1. Explain why  $3 \times 5 \times 7 + 7$  is a composite number.



[Watch Video Solution](#)

2. Find the distance of the point  $(7,-8)$  from the origin



[Watch Video Solution](#)

3. Find the ratio in which the line segment joining the points  $(-1,7)$  and  $(4,-3)$  is divided by the point  $(1,3)$ .



[Watch Video Solution](#)

4. For the following distribution, find the sum of the lower limits of the median class and the modal

class:

Class	0-5	5-10	10-15	15-20	20-25
Frequency	10	15	12	20	9



[Watch Video Solution](#)

5.  $\triangle ABC$  is an equilateral triangle such that  $AD \perp BC$ , then  $AD^2 =$



[Watch Video Solution](#)

6. An equilateral triangle  $ABC$  is inscribed in a circle with centre  $O$ . The measures of  $\angle BOC$  is  $30^\circ$   
(b)  $60^\circ$  (c)  $90^\circ$  (d)  $120^\circ$



[Watch Video Solution](#)

7. If  $2 \cos 3\theta = \sqrt{3}$  ( $0^\circ \leq \theta \leq 90^\circ$ ), then find the value of  $\theta$ .



[Watch Video Solution](#)

8. What is the perimeter of triangle with vertices  $(0,0)$ ,  $(1,0)$  and  $(0,1)$ .



[Watch Video Solution](#)

9. On melting a solid sphere of lead of radius 8 cm , find the number of spherical balls of radius 1 cm that can be made?



[Watch Video Solution](#)

10. If the area of a sector of a circle of radius 2 cm is  $\pi$  sq m, then what is the central angle of the sector ?



[Watch Video Solution](#)

11. If 18,  $a$ ,  $b$ ,  $-3$  are in AP, then  $a + b =$



[Watch Video Solution](#)

12. In  $\triangle ABC$ ,  $D$  and  $E$  are points on the sides  $AB$  and  $AC$  respectively, such that  $DE \parallel BC$ . If  $AD=2.5\text{cm}$ ,  $BD=3\text{cm}$  and  $AE = 3.75\text{ cm}$ , then the value of  $AC$ .



[Watch Video Solution](#)

13. In the given figure ,if  $\angle MPQ = 40^\circ$  , then find the  $\angle OPM$ .

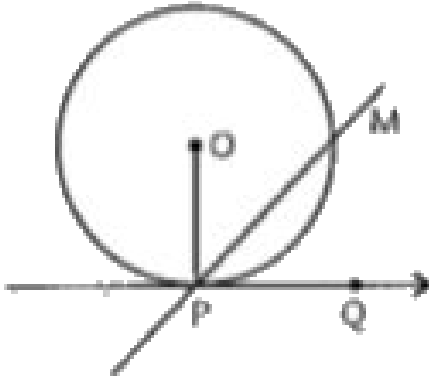

[▶ Watch Video Solution](#)

14. Write the empirical relation between mean, mode and median.

[▶ Watch Video Solution](#)

**15.** If the product of the zeros of the polynomial  $ax^2 - 6x - 12$  is 4 , then find the value of 'a' .



**Watch Video Solution**

**16.** In an A.P., If  $a=21$  ,  $d=-3$  and  $a_n = 0$  , then find the value of 'n' .



**Watch Video Solution**

**17.** Write a quadratic equation whose zeros are -7 and 5.





Watch Video Solution

18. A playgroup school is looking to refurbish the playground area that is in almost a triangular shape (ABC). There is a small tree, almost a vertical line in shape lets say AD, at the corner of the playground area

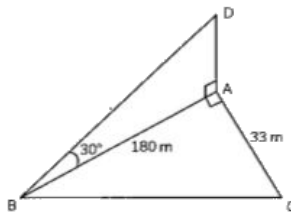
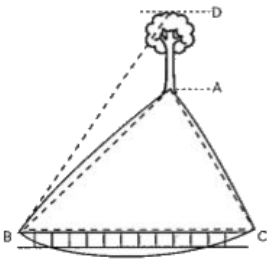

A path runs along the edge BC of the field. As part of material purchase planning, the playgroup manager needs to scope out the surrounding area

including the dimensions of the tree.

The height of the tree AD is :

A.  $29\sqrt{3}m$

B.  $38\sqrt{3}m$

C.  $43\sqrt{3}m$

D.  $60\sqrt{3}m$

**Answer:**



**Watch Video Solution**

19. A playgroup school is looking to refurbish the playground area that is in almost a triangular shape (ABC). There is a small tree, almost a vertical line in shape lets say AD, at the corner of the playground area

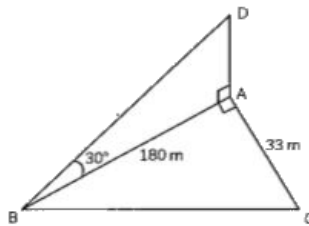
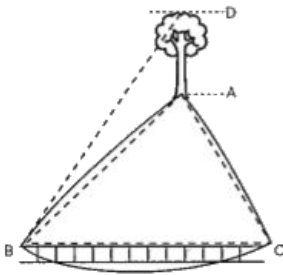

A path runs along the edge BC of the field. As part of material purchase planning, the playgroup manager needs to scope out the surrounding area including the dimensions of the tree.

On the basis of the above information, answer any

four of the following questions :

The length of the path BC is :

A. 193 m

B. 189 m

C. 188m

D. 183 m

**Answer:**



**Watch Video Solution**

20. A playgroup school is looking to refurbish the playground area that is in almost a triangular shape (ABC). There is a small tree, almost a vertical line in shape lets say AD, at the corner of the playground area

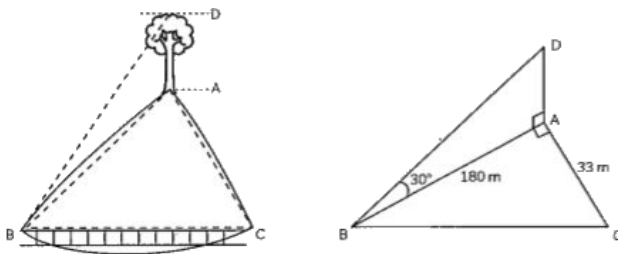

A path runs along the edge BC of the field. As part of material purchase planning, the playgroup manager needs to scope out the surrounding area including the dimensions of the tree.

On the basis of the above information, answer any

four of the following questions :

The area (in sq m) of the field ABC is :

A. 2790 sq m

B. 2970 sq m

C. 3102 sq m

D. 3210 sq m

**Answer:**



**Watch Video Solution**

21. A playgroup school is looking to refurbish the playground area that is in almost a triangular shape (ABC). There is a small tree, almost a vertical line in shape lets say AD, at the corner of the playground area

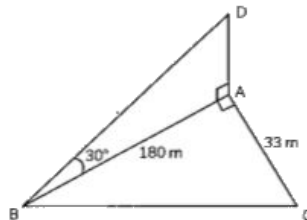
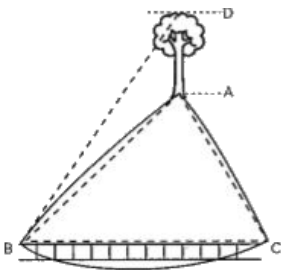

A path runs along the edge BC of the field. As part of material purchase planning, the playgroup manager needs to scope out the surrounding area including the dimensions of the tree.

The length BD is :

A. 198 m

B. 208 m

C. 228 m

D. 243 m

**Answer:**



**Watch Video Solution**

**22.** In CERN , some work is carried out for developing an accurate and fast numerical method that can calculate natural gas flow in a pipeline under non isothermal steady -state conditions .



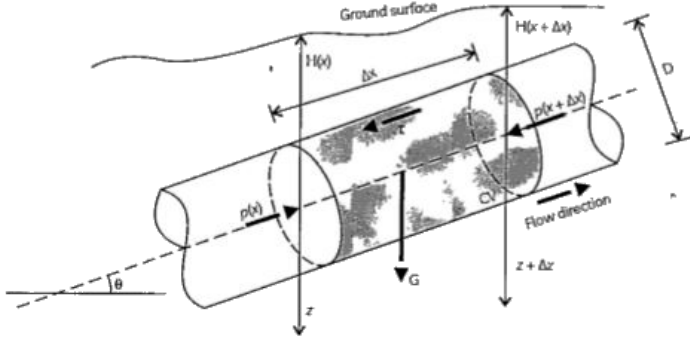

The cross section of the pipeline is shown below:

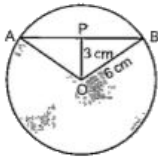

Diagram 1

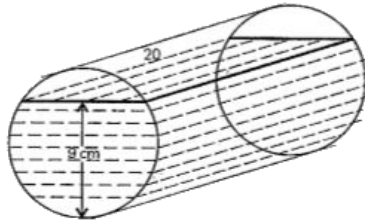

Diagram 2

In Diagram 1, O is the centre of the circle of radius 6 cm and P is the mid-point of the chord AB. The length OP is 3 cm.

The measure of  $\angle AOB$  is :

A.  $60^\circ$

B.  $75^\circ$

C.  $120^\circ$

D.  $135^\circ$

**Answer:**



**Watch Video Solution**

**23.** In CERN , some work is carried out for developing an accurate and fast numerical method that can calculate natural gas flow in a pipeline under non isothermal steady -state conditions .

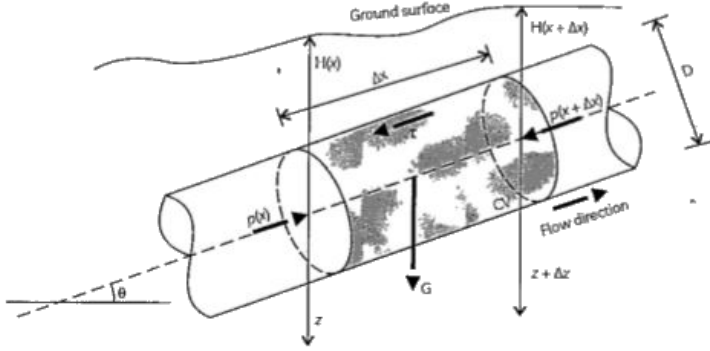

The cross section of the pipeline is shown below:

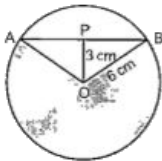

Diagram 1

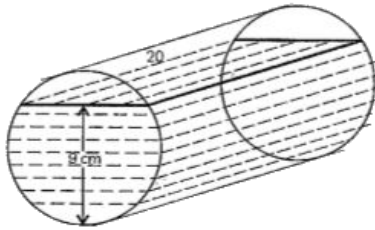

Diagram 2

In Diagram 1, O is the centre of the circle of radius 6 cm and P is the mid-point of the chord AB. The length OP is 3 cm.

The area (in sq cm) of  $\triangle AOB$  is :

A. 5.2

B. 10.4

C. 15.6

D. 20.8

**Answer:**



**Watch Video Solution**

**24.** Resident Welfare Association (RWA) of a M2 K Society in Azadpur have put up three electric poles A,B and C in a society 's common park near Tower A . Despite these poles ,some parts of the park are still in dark. So , RWA decides to have one more electron pole D in the park.

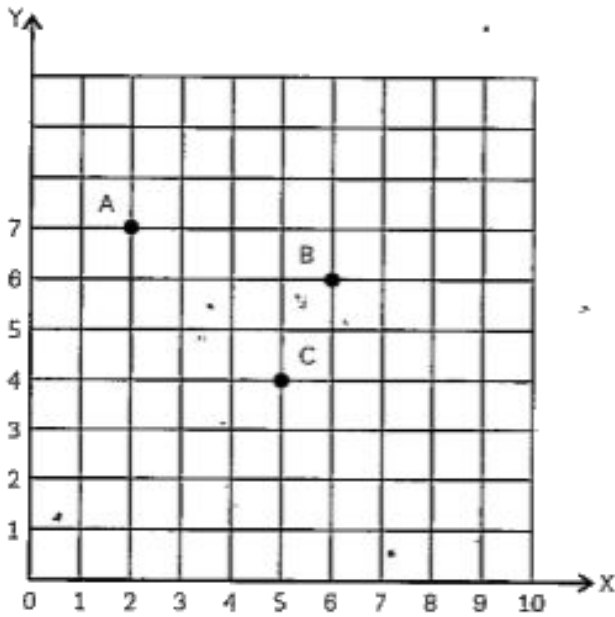

The position of the pole C is :

A. (5,4)

B. (2,7)

C. (8,9)

D. (9,8)

**Answer:**



**Watch Video Solution**

**25.** Resident Welfare Association (RWA) of a M2 K Society in Azadpur have put up three electric poles A,B and C in a society 's common park near Tower A . Despite these poles ,some parts of the park are still in dark. So , RWA decides to have one more

electron pole D in the park.

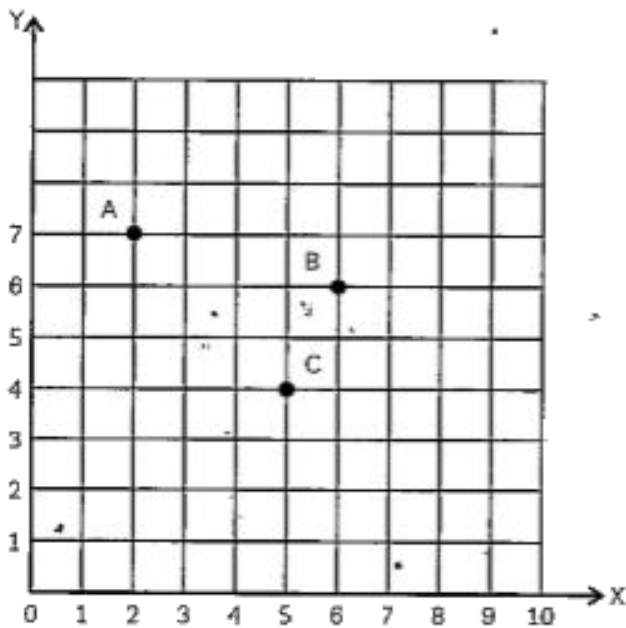

The distance of the pole B from the corner O of the park is :

A.  $\sqrt{53}$  units

B.  $\sqrt{41}$  units

C.  $\sqrt{72}$  units

D.  $\sqrt{145}$  units

**Answer:**



**Watch Video Solution**

**26.** Resident Welfare Association (RWA) of a M2 K Society in Azadpur have put up three electric poles A, B and C in a society 's common park near Tower A . Despite these poles ,some parts of the park are



still in dark. So , RWA decides to have one more electron pole D in the park.

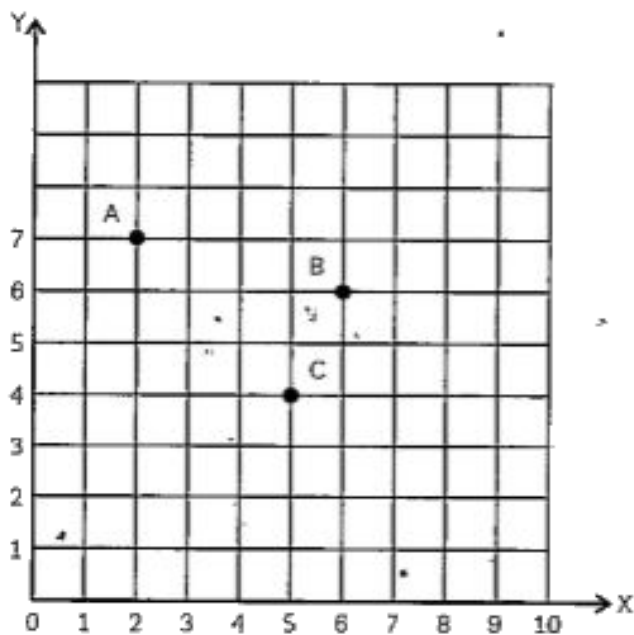

The position of the fourth pole D so that four points A,B,C and D form a parallelogram is :

A. (1,4)

B. (1,5)

C. (2,3)

D. (5,1)

**Answer:**



**Watch Video Solution**

**27.** Resident Welfare Association (RWA) of a M2 K Society in Azadpur have put up three electric poles A,B and C in a society 's common park near Tower A . Despite these poles ,some parts of the park are still in dark. So , RWA decides to have one more electron pole D in the park.

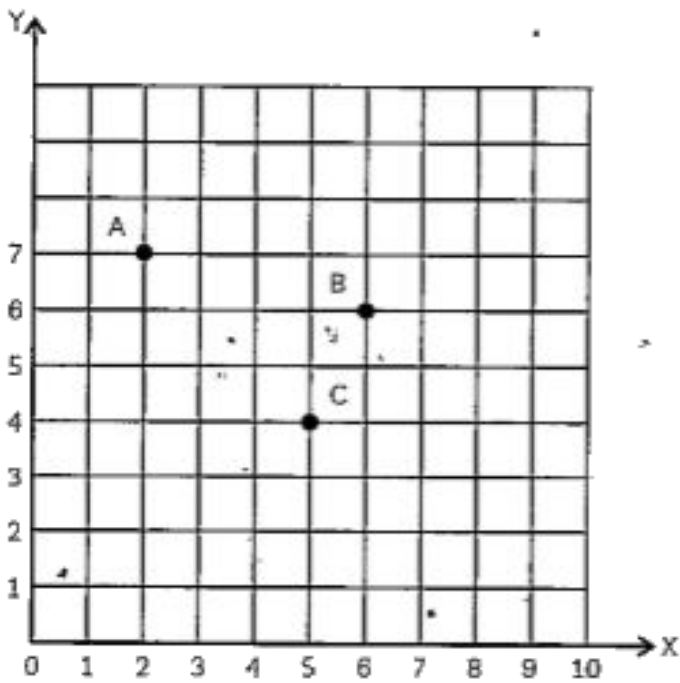

On the basis of the above information ,answer any

four of the following questions :

The distance between poles A and C is :

A.  $\sqrt{18}$  units

B.  $\sqrt{17}$  units

C.  $\sqrt{5}$  units

D.  $\sqrt{34}$ units

**Answer:**



**Watch Video Solution**

**28.** Resident Welfare Association (RWA) of a M2 K Society in Azadpur have put up three electric poles A,B and C in a society 's common park near Tower A . Despite these poles ,some parts of the park are still in dark. So , RWA decides to have one more electron pole D in the park.

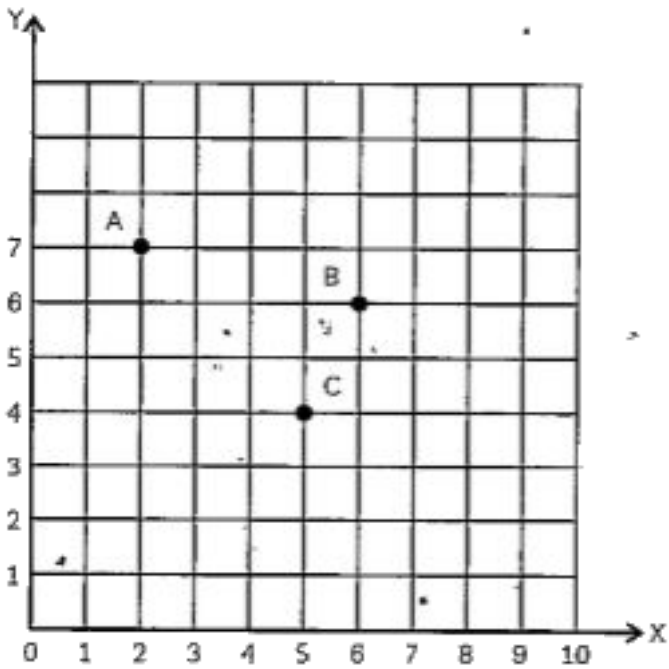

Plot a point D so that ABCD becomes parallelogram

.The distance between poles B and D is :

A.  $\sqrt{24}$  units

B.  $\sqrt{17}$  units

C.  $\sqrt{5}$  units

D.  $\sqrt{26}$  units

**Answer:**



**Watch Video Solution**

**29.** Write any two irrational numbers whose product is rational number.



**Watch Video Solution**



30. If the zeroes of the polynomial  $x^3 - 3x^2 + x + 1$  are  $a, b, a + b$ , find  $a$  and  $b$ .



[Watch Video Solution](#)

31. Given the linear equation  $2x + 3y - 8 = 0$ , write another linear equation in two variables such that the geometrical representation of the pair so formed is (i) intersecting lines (ii) Parallel lines (iii) coincident lines



[Watch Video Solution](#)

**32.** Given the linear equation  $2x + 3y - 8 = 0$ , write another linear equation in two variables such that the geometrical representation of the pair so formed is coincident lines



**Watch Video Solution**

**33.** The product of A's age 5 years ago with his age 9 years later is 15. Find A's present age .



**Watch Video Solution**

34. If  $x = r \sin A \cos C$ ,  $y = r \sin A \sin C$  and  $z = r \cos A$ , prove that  $r^2 = x^2 + y^2 + z^2$



Watch Video Solution

35.

Prove

$$(\tan \theta + 2)(2 \tan \theta + 1) = 5 \tan \theta + 2 \sec^2 \theta.$$



Watch Video Solution

36. A cow is tied with a rope of length 14m at the corner of a rectangular field of dimensions

$20m \times 16m$  . Find the area of the field in which the cow can graze.



[Watch Video Solution](#)

37. Prove that  $\sqrt{3}$  is an irrational number



[Watch Video Solution](#)

38. Find the roots of the equation :

$$\frac{1}{x+4} - \frac{1}{x-7} = \frac{11}{30} \quad (x \neq -4, 7)$$



[Watch Video Solution](#)

**39.** Find a fraction which becomes  $\frac{1}{2}$  when the denominator is increased by 4, and  $\frac{1}{8}$  when the numerator is decreased by 5.



**Watch Video Solution**

**40.** In the given figure, a square OABC is inscribed in a quadrant OPBQ. If  $OA = 20$  cm, find the area of

the shaded region (Use  $\pi = 3.14$ )

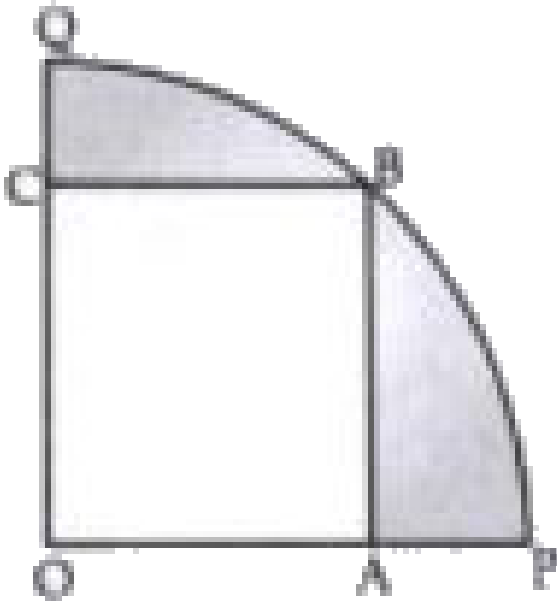

[▶ Watch Video Solution](#)

**41.** Draw a circle of radius 3 cm. From a point 5 cm from the centre of the circle, draw two tangents to the circle. Measure the length of each tangent.



 [Watch Video Solution](#)

42. State and prove the Pythagoras theorem.

 [Watch Video Solution](#)

43. The annual rainfall record of a city for 66 days is given below in the table :

Rainfall (in cm)	0-10	10-20	20-30	30-40	40-50	50-60
Number of days	22	10	8	15	5	6

Calculate the median rainfall ,using the formula .

 [Watch Video Solution](#)

44. Prove that

$$\frac{\cot \theta + \operatorname{cosec} \theta - 1}{\cot \theta - \operatorname{cosec} \theta + 1} = \frac{1 + \cos \theta}{\sin \theta}.$$



Watch Video Solution

45. Prove that

$$\frac{\tan A}{(1 - \cot A)} + \frac{\cot A}{(1 - \tan A)} = (1 + \tan A + \cot A).$$



Watch Video Solution

46. If the sum of the zeros of the polynomial

$2x^2 + 3kx + 3$  is 6, then find the value of  $k$ .







[Watch Video Solution](#)

47. When a pair of linear equations is said to be inconsistent?



[Watch Video Solution](#)

48. Find the roots of the quadratic equation  
 $(3x - 5)(x + 3) = 0$ .



[Watch Video Solution](#)

**49.** Find the sum of natural numbers from 51 to 100.



[Watch Video Solution](#)

**50.** Find the  $8^{th}$  term from the end of the A.P.  
 $-12, -7, -2, \dots, 68$



[Watch Video Solution](#)

**51.** How many terms of AP:  $18, 16, 14, \dots$  make the sum zero?



[Watch Video Solution](#)

52. For what value of  $a$  is  $-4$  zero of the polynomial  $p(x) = x^2 - x - (2a + 2)$ ?



[Watch Video Solution](#)

53. If  $A(6, 2)$ ,  $B(4, 2)$  and  $C(6, 4)$  are the vertices of  $\triangle ABC$ , then find the length of the median through  $C$ .



[Watch Video Solution](#)

**54.** The base PQ of two equilateral triangles PQR and PQR with side 2a lies along y-axis such that the mid-point of PQ is at the origin. Find the coordinates of the vertices R and R of the triangles.



[Watch Video Solution](#)

**55.** In a  $\triangle ABC$ , if DE is parallel to BC,  $\frac{AD}{DB} = \frac{3}{4}$  and AC = 15 cm, then find the length AE.



[Watch Video Solution](#)

**56.** If the bisector of an angle of a triangle bisects the opposite side, prove that the triangle is isosceles.



**Watch Video Solution**

**57.** Draw a line segment of length 7 cm and divide it in the ratio 2:3.



**Watch Video Solution**

**58.** Two concentric circles are of radii 5 cm and 3 cm. Find the length of the chord of the larger circle which touches the smaller circle.



**Watch Video Solution**

**59.** Write the formula for the area of a sector of angle  $\theta$  (in degrees) of a circle of radius  $r$ .



**Watch Video Solution**

**60.** If the perimeter of a semicircular protractor is 36cm, find its diameter.



**Watch Video Solution**

**61.** If  $P(E) = 0.005$ , then find the probability of "not E".



**Watch Video Solution**

**62.** An unbiased dice is rolled once. What is the probability of getting an even prime number?



Watch Video Solution

63. If  $\sin B = 0.5$ , find the value of  $3 \cos B - 4 \cos^3 B$



Watch Video Solution

64. Find the value of  $\operatorname{cosec}^2 30^\circ \sin^2 45^\circ - \sec^2 60^\circ$



Watch Video Solution



**65.** Mr. Naik is a paramilitary Intelligence Corps officer who is tasked with planning a coup on the enemy at a certain date. Currently he is inspecting the area standing on top of the cliff. Agent Vinod is on a hot air balloon in the sky. When Mr. Naik looks down below the cliff towards the sea, he has Ajay and Maran in boats positioned to get a good vantage point.

The main goal is to scope out the range and angles at which they should train their soldiers.

Which one is a pair of 'angles of elevation'?

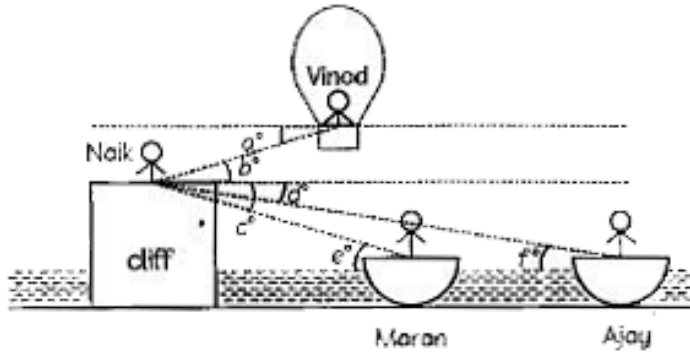

- A. ( $Za^\circ$ ,  $Ze^\circ$ )
- B. ( $Zb^\circ$ ,  $Ze^\circ$ )
- C. ( $Zc^\circ$ ,  $Zd$ )
- D. ( $Za^\circ$ ,  $Zf^\circ$ )

**Answer:**



**Watch Video Solution**

**66.** Mr. Naik is a paramilitary Intelligence Corps officer who is tasked with planning a coup on the enemy at a certain date. Currently he is inspecting the area standing on top of the cliff. Agent Vinod is on a hot air balloon in the sky. When Mr. Naik looks down below the cliff towards the sea, he has Ajay and Maran in boats positioned to get a good vantage point.

The main goal is to scope out the range and angles at which they should train their soldiers.

which one is a pair of 'angles of depression'?

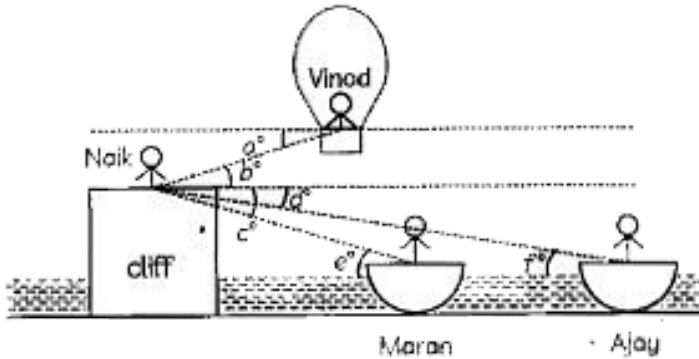

A. ( $Za^\circ$ ,  $Ze^\circ$ )

B. ( $Zb^\circ$ ,  $Ze^\circ$ )

C. ( $Zc^\circ$ ,  $Zd^\circ$ )

D. ( $Za^\circ$ ,  $Zf^\circ$ )

**Answer:**



**Watch Video Solution**

**67.** Mr. Naik is a paramilitary Intelligence Corps officer who is tasked with planning a coup on the enemy at a certain date. Currently he is inspecting the area standing on top of the cliff. Agent Vinod is on a hot air balloon in the sky. When Mr. Naik looks down below the cliff towards the sea, he has Ajay and Maran in boats positioned to get a good vantage point.

The main goal is to scope out the range and angles at which they should train their soldiers.

Ajay's boat is 25 m away from the base of the cliff.

If  $\angle d = 30^\circ$ . What is the height of the cliff? (use

$$\sqrt{3} = 1.73)$$

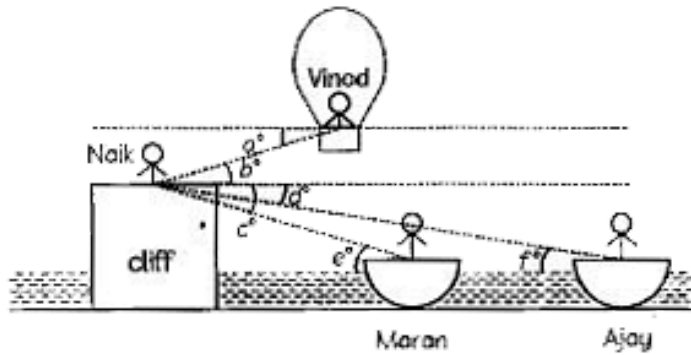

- A. 17.5 m
- B. 12.26 m
- C. 14.45 m
- D. 15.4 m

**Answer:**



**Watch Video Solution**

**68.** Mr. Naik is a paramilitary Intelligence Corps officer who is tasked with planning a coup on the enemy at a certain date. Currently he is inspecting the area standing on top of the cliff. Agent Vinod is on a hot air balloon in the sky. When Mr. Naik looks down below the cliff towards the sea, he has Ajay and Maran in boats positioned to get a good vantage point.

The main goal is to scope out the range and angles at which they should train their soldiers.

If the height of the cliff is  $30m$ ,  $\angle c = 45^\circ$  and  $\angle d = 30^\circ$ , distance between the two boats is

(use  $(\sqrt{3} = 1.73)$ )

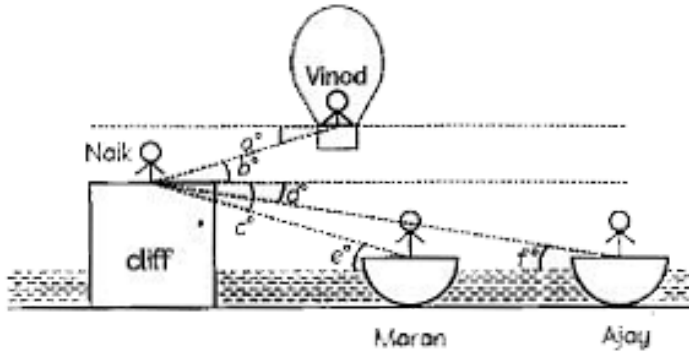

- A. 6.8 m
- B. 8.5 m
- C. 11.2 m
- D. 21.9 m

**Answer:**

 [Watch Video Solution](#)



69. Mr. Naik is a paramilitary Intelligence Corps officer who is tasked with planning a coup on the enemy at a certain date. Currently he is inspecting the area standing on top of the cliff. Agent Vinod is on a hot air balloon in the sky. When Mr. Naik looks down below the cliff towards the sea, he has Ajay and Maran in boats positioned to get a good vantage point.

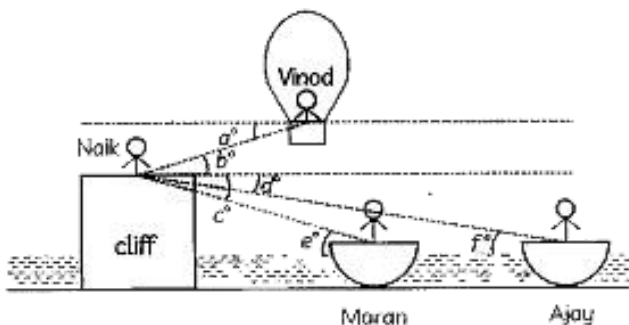

The main goal is to scope out the range and angles at which they should train their soldiers.

If the vertical height of the balloon from the top of the cliff is 12 m and  $\angle b = 30^\circ$ , then the distance between the Naik and vinod is

A. 6m

B. 12m

C. 18 m

D. 24 m

**Answer:**



**Watch Video Solution**

70. Thermas Housewares Co. Ltd is one of the leading brands in the field of vacuum flask. They are producing a new high-quality heat preservation flask series and the below figure shows the cross - section of the interior part of a new concept thermos flask.

The top part is a trapezium, the middle part is a rectangle and the bottom part is a semi-circle

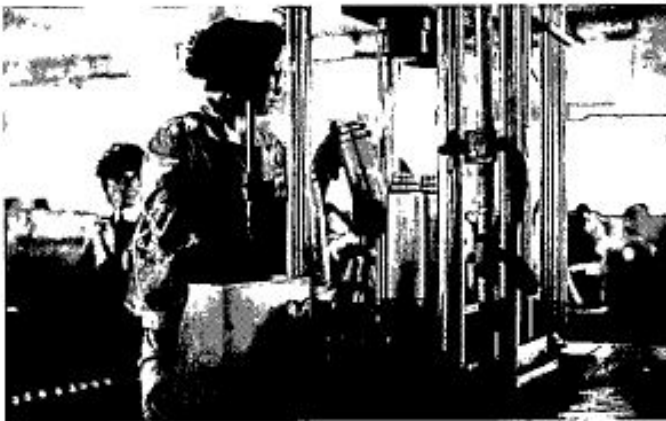

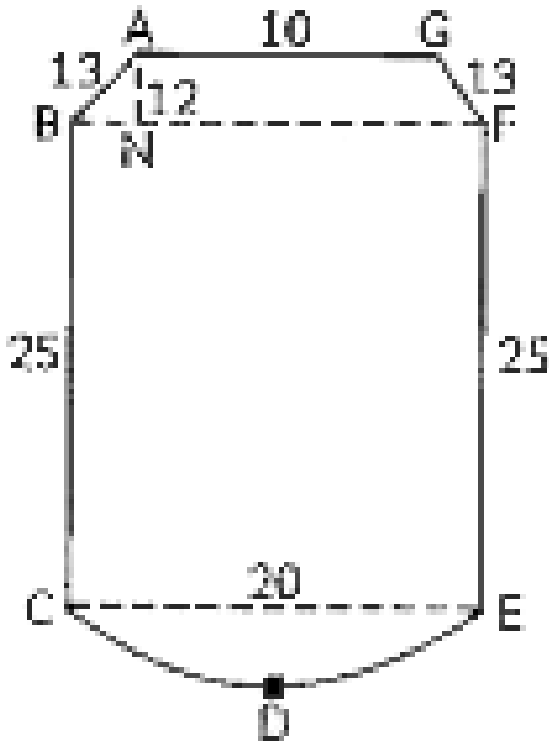

The dimension of various parts are:

$CE = 20$  cm,  $BC = 25$  cm,  $AB = GF = 13$  cm,  $AG = 10$  cm

and  $AN = 12$  cm

The perimeter of the trapezium part of the cross section, is

A. 36 cm

B. 56 cm

C. 30 cm

D. 46 cm

**Answer:**



**Watch Video Solution**

**71.** Thermas Housewares Co. Ltd is one of the leading brands in the field of vacuum flask. They are producing a new high-quality heat preservation flask series and the below figure shows the cross -

section of the interior part of a new concept  
thermos flask.

The top part is a trapezium, the middle part is a  
rectangle and the bottom part is a semi-circle

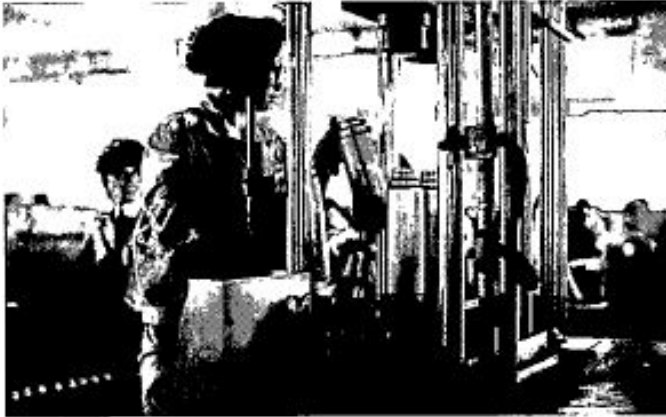

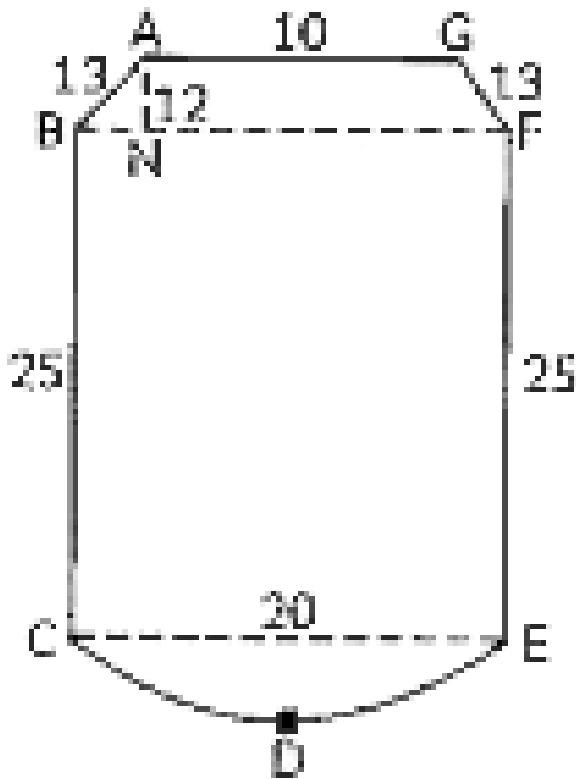

The dimension of various parts are:

$CE = 20$  cm,  $BC = 25$  cm,  $AB = GF = 13$  cm,  $AG = 10$  cm

and  $AN = 12$  cm

The perimeter of the rectangular part of the cross section, is

A. 90 cm

B. 70 cm

C. 50 cm

D. 40 cm

**Answer:**



**Watch Video Solution**

**72.** Using prime factorisation, find the HCF and LCM of 150 and 240.



**Watch Video Solution**



**73.** Find the ratio in which the line segment joining the points  $(-3, 10)$  and  $(6, -8)$  is divided by  $(-1, 6)$ .



[Watch Video Solution](#)

**74.** Using distance formula, show that the points  $A(1, -1)$ ,  $B(5, 2)$  and  $C(9, 5)$  are collinear.



[Watch Video Solution](#)

**75.** Rasheed got a playing top (lattu) as his birthday present, which surprisingly had no colour on it. He wanted to colour it with his crayons. The top is shaped like a cone surmounted by a hemisphere. The entire top is 5 cm in height and the diamete



**Watch Video Solution**

**76.** In an A.P., the last term is 28 and the sum of all the 9 terms of the A.P. is 144. Find the first term.



**Watch Video Solution**

**77.** In what ratio does the x-axis divide the line segment joining the points  $(-4,-6)$  and  $(-1,7)$ ? Find the co-ordinates of the point of division.



**Watch Video Solution**

**78.** Prove that the parallelogram circumscribing a circle is a rhombus.



**Watch Video Solution**

**79.** The diagonal  $BD$  of a parallelogram  $ABCD$  intersects the segment  $AE$  at the point  $F$ , where  $E$  is any point on the side  $BC$ . Prove that  $DF \times EF = FB \times FA$ .



[Watch Video Solution](#)

**80.** In the given figure, are shown two arcs  $PAQ$  and  $PBQ$ . Arc  $PAQ$  is a part of circle with centre  $O$  and radius  $OP$  while arc  $PBQ$  is a semi-circle drawn on  $PQ$  as diameter with centre  $M$ . If  $PQ = OP = 10$  cm show that area of shaded region is  $25\left(\sqrt{3} - \frac{\pi}{6}\right)$ .



[Watch Video Solution](#)

 [Watch Video Solution](#)

**81.** A Hollow cone is cut by a plane parallel to the base and upper portion is removed. If the curved surface of the remainder is  $\frac{8}{9}$  of the curved surface of the whole cone; find the ration of the line-segment into which the cone's altitude is divided by the plane.



[Watch Video Solution](#)

**82.** A two digit number is four times the sum and three times the product of its digits.

 Watch Video Solution

83. In the given figure,  $\triangle FEC$  is congruent to  $\triangle GDB$  and  $\angle 1 = \angle 2$ . Prove that  $\triangle ADE \sim \triangle ABC$

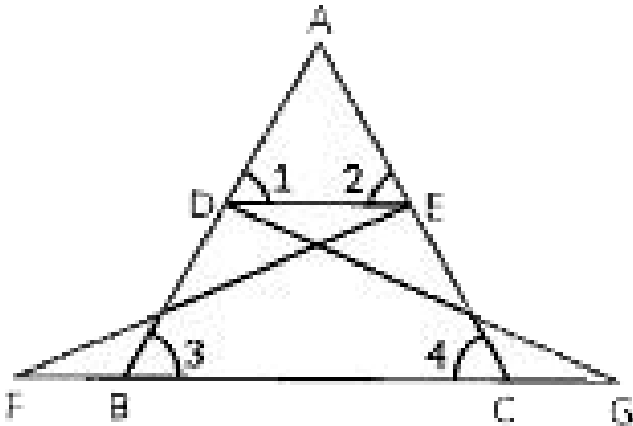

 Watch Video Solution

84. If an isosceles triangle  $ABC$  in which  $AB = AC = 6\text{cm}$  is inscribed in a circle of radius  $9\text{cm}$ , find the area of the triangle.



Watch Video Solution

85. From an aeroplane vertically above a straight horizontal road, the angles of depression of two consecutive mile stones on opposite sides of the aeroplane are observed to be  $\alpha$  and  $\beta$ . Show that the height in miles of aeroplane above the road is

give by  $\frac{\tan \alpha \tan \beta}{\tan \alpha + \tan \beta}$



Watch Video Solution



**Watch Video Solution**