



MATHS

BOOKS - NAGEEN PRAKASHAN

ENGLISH

**VOLUME AND SURFACE AREA OF
SOLIDS**

Solved Examples

1. A tent of cloth is cylindrical up to 1 m height and conical above it of the same radius of base . If the diameter of tent is 6 m and the slant height of conical part is 5 m, find the cloth required to make this tent



[Watch Video Solution](#)

2. A toy is in the form of a cone mounted on a hemisphere of radius 3.5 cm. The total height

of the toy is 15.5 cm find the total surface area and volume of the toy.



[Watch Video Solution](#)

3. The base and top of a right circular cylindrical drum are hemispherical .The diameter of cylindrical part is 14 cm and total height is 30 cm .Find the total surface area of the drum.



[Watch Video Solution](#)

4. There is a hemispherical roof on the cylindrical room .There is 5236 m^3 air in this room .The inner diameter of the floor is equal to the maximum height of the room. Find the height of room . (Given that $\pi=3.1416$)



[Watch Video Solution](#)

5. Three cubes each with 8 cm edge are joined end to end. Find the total surface area of the resulting cuboid.



[Watch Video Solution](#)

6. A rectangular sheet of tin $58\text{ cm} \times 44\text{ cm}$ is to be made into an open box by cutting off equal squares from the corners and folding up the flaps. What should be the volume of box if the surface area of box is 2452 cm^2 ?



[Watch Video Solution](#)

7. There is some water in a cylindrical vessel of diameter 11 cm. A solid cube of side 5.5 cm is

dropped into the water, which immersed completely in the water. Find the increase in the height of surface of water in the vessel.



[Watch Video Solution](#)

8. The radii of two right circular cylinders are in the ratio 2: 3 and their heights are in the ratio 5:4 calculate the ratio of their curved surface areas and also the ratio of their



[Watch Video Solution](#)

9. about to only mathematics



[Watch Video Solution](#)

10. In a rain water harvesting system the rain water from a roof of $22\text{ m} \times 20\text{ m}$ drains in to a cylindrical tank having diameter of base 2 m and height 3.5 m . If the tank is full find the rainfall in cm . Write your views on water conservation.



[Watch Video Solution](#)

11. Volume and surface area of a solid hemisphere are numerically equal what is the diameter of the hemisphere?



Watch Video Solution

12. The curved surface area of a cone of height 8 m is 188.4 m^2 . Find the volume of cone



Watch Video Solution

13. A conical tent is required to accommodate 157 persons each person must have 2 m^2 of space on the ground and 15 m^3 of air to breath .Find the height of the tent , also calculate the slant height.



Watch Video Solution

14. The radius and height of a solid right circular cone are in the ratio of 5:12 .If its

volume is 314 cm^3 Find its total surface area .

[Take $\pi = 3.14$]



[Watch Video Solution](#)

15. A right angle triangle with sides 3 cm and 4 cm is revolved around its hypotenuse . Find the volume of the double cone thus generated.



[Watch Video Solution](#)

16. If h, C, V respectively are the height, the curved surface area and volume of a cone.

Prove that $3\pi Vh^3 - C^2h^2 + 9V^2 = 0$.



[Watch Video Solution](#)

17. A cone of equal height and equal base is cut off from a cylinder of height 24 cm and base radius 7 cm .Find the total surface and volume of remaining solid.



[Watch Video Solution](#)

18. From a wooden cubical block of edge 7 cm , the largest possible right conical piece is cut out whose base is on one of the faces of the cube. Calculate .

(i) the volume of the wood left in the block and

the total surface area of the block left (Taken

$$\pi = \frac{22}{7}$$



Watch Video Solution

19. A sphere is inscribed in a cylinder such that sphere touches the cylinder . Show that the curved surface of sphere is equal to the curved surface of cylinder.



[Watch Video Solution](#)

20. The largest possible cube is made from a wooden sphere of radius $6\sqrt{3}cm$. Find the surface area of the cube.



[Watch Video Solution](#)

21. The adjoining figure represents a solid consisting of a cylinder surmounted by a cone at one end and a hemisphere at the other end. Given that common radius = 3.5 cm the height of the cylinder = 6.5 cm and the total height = 12.8 cm , calculate the volume of the solid correct to the nearest cm.

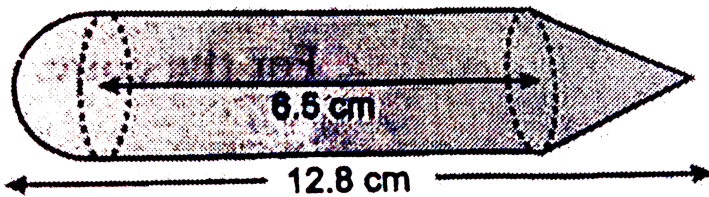

[Watch Video Solution](#)

22. From a solid cylinder of height 36 cm and radius 14 cm, a conical cavity of radius 7 cm and height 24 cm is drilled out. Find the volume and the total surface area of the remaining solid.



Watch Video Solution

23. A hemisphere is inscribed in a cylinder and a cone is inscribed in the hemisphere. The vertex of cone lies on the centre of the upper

circular part of the cylinder .Show that , $\frac{1}{3} \times$
Volume of cylinder $= \frac{1}{2} \times$ Volume of
hemishpere= Volume of cone



[Watch Video Solution](#)

24. A tank measures 2 m long 1.6 m wide and 1m depth water is there up to 0.4 m height .Bricks measuring $25cm \times 14cm \times 10cm$ are put in to the tank so that water may come up to the top. Each brick absorbs water equal to

$\frac{1}{7}$ th of its own volume

How many bricks will be needed?



[Watch Video Solution](#)

25. A solid metal sphere is melted and smaller spheres of equal radii are formed. 10% of the volume of the sphere is lost in the process. The smaller spheres have a radius, that is $\frac{1}{9}$ th the larger sphere. If 10 litres of paint were needed to paint the larger sphere. Find how

many letres are needed to paint all the smaller spheres?



[Watch Video Solution](#)

26. A metallic solid sphere of radius 10.5 is melted and recasted in to smaller solid cones each of radius 3.5 cm and height 3 cm .How many cones will be made?



[Watch Video Solution](#)

27. The three different face diagonals of a cuboid (rectangular parallelepiped) have lengths 39, 40 and 41 units. Find the length of the main diagonal of the cuboid which joins a pair of opposite corners.



Watch Video Solution

28. Three spheres of radius ' r ' are kept inside a cylinder such that two of the spheres are at the bottom touching each other and sides of the

cylinder while the third sphere is touching the two bottom spheres and the top of the cylinder .Find the volume of the cylinder .



[Watch Video Solution](#)

29. Water in a canal 5.4 m wide and 1.8 m deep is following with a speed of 25km/hr How much area can it irrigate in 40 minutes if 10 cm of standing water is required for irrigation?



[Watch Video Solution](#)

30. A solid metallic cuboid of dimensions $9m \times 8m \times 2$ is melted and recast in to solid cubes of edge 2 m .find the number of cubes so formed.



[Watch Video Solution](#)

31. Three cubes of metal whose edges are in the ratio 3:4:5 are melted down in to a single cube whose diagonal is $12(\sqrt{3})$ cm. Find the edges of the three cubes.



[Watch Video Solution](#)

32. A cube of metal of 2.5 cm edge is melted and cast in to rectangular solid whose base is 1.25 cm by 0.25 cm .Assuming no loss in melting find the height of the solid . Also find the gain in the surface area.



Watch Video Solution

33. A granary is in the shape of a cuboid of size $8m \times 6m \times 3m$ If a bag of grain occupies a space

of $0.65m^3$, how many bags can be stored in the granary?



[Watch Video Solution](#)

34. A cylindrical bucket 28 cm in diameter and 72 cm high is full of water . The water is emptied in to a rectangular tank 66 cm long and 28 cm wide .Find the height of water level in the tank.



[Watch Video Solution](#)

35. A rectangular container whose base is a square of side 15 cm stands on a horizontal table and holds water up to 3cm from the top .When a cube is placed in the water and is completely submerged , the water rises to the top and 54 cm^3 of water overflows.

Calculate the volume of the cube and its surface area.



Watch Video Solution

36. A solid spherical ball of iron with radius 6 cm is melted and recast into three solid spherical balls. The radii of the two of the balls are 3 cm and 4 cm respectively determine the diameter of the third ball.



Watch Video Solution

37. 50 circular plates each of radius 7 cm and thickness 0.5 cm are placed one above the other to form a solid right circular cylinder

.Find (i) the total surface area and (ii) the volume of the cylinder so formed.



[Watch Video Solution](#)

38. A rectangular paper of $22 \text{ cm} \times 12 \text{ cm}$ is folded in two different ways and formed two cylinders .

(i) Find the ratio of the volumes of two cylinders

(ii) Find the difference of the volumes of two cylinders.



[Watch Video Solution](#)

39. A semicircle of radius 17.5 cm is rotated about its diameter. Find the curved surface of the solid so generated.



[Watch Video Solution](#)

40. The rain water from a roof of dimensions $22\text{m} \times 20\text{m}$ drains into a cylindrical vessel having a diameter of bases 2 m and height 3.5 m. If the rain water collected from the roof

just fill the cylindrical vessel, then find the rainfall (in cm).



[Watch Video Solution](#)

41. A sphere of radius 6 cm is melted and recast into a cone of height 6 cm. Find the radius of the cone.



[Watch Video Solution](#)

42. The height and radius of base of a metallic cone are 27 cm and 16 cm respectively .It is melted and recast into a sphere .Find the radius and curved surface of the sphere.



Watch Video Solution

43. There is some water in a cylindrical vessel of diameter 12 cm. A solid metallic sphere of radius 4 cm is dropped in to it . Find the

increase in height of the water surface if sphere is fully immersed in to the water.



[Watch Video Solution](#)

44. The radius of a metallic sphere is 60 mm .It is melted and recast in to wire of diameter 0.8 mm .Find the length of the wire.



[Watch Video Solution](#)

45. A copper wire, 3 mm in diameter, is wound about a cylinder whose length is 12 cm , and diameter 10 cm , so as to cover the curved surface of the cylinder. Find the length and mass of the wire, assuming the density of copper to be 8.88 g per cm^3



Watch Video Solution

46. A metallic cylinder of diameter 16 cm and height 9 cm is melted and recast in to sphere

of diameter 6cm .How many such spheres can be formed?



[Watch Video Solution](#)

47. A solid metallic right circular cone of height 6.75 cm and radius of the base 12 cm is melted and two solid spheres formed from it. If the volume of one of the sphere is 8 times that of the other find the radius of the smaller sphere.



[Watch Video Solution](#)

48. The radius of a spherical ball of iron is 1.5 cm .It is melted and recast into three spherical balls .If the radii of two such balls are 0.75 cm and 1 cm , then find the radius of 3rd ball .



Watch Video Solution

49. The diameter of a hollow cylindrical vessel is 14 cm .There is some water in it. When a cubical iron piece is fully immersed in it , the

water surface rises by $8\frac{9}{14}$ cm .Find the edge of the cube.



[Watch Video Solution](#)

50. How many metallic balls of radius 1 cm can be recast by melting a metallic sphere of radius 8 cm?



[Watch Video Solution](#)

51. Water is flowing at the rate of 3km/hr through a circular pipe of 20cm internal diameter into a circular cistern of diameter 10m and depth 2m. In how much time will the cistern be filled?



[Watch Video Solution](#)

52. Volume of a sphere is $288 \pi \text{cm}^3$. 27 small spheres can be formed with this sphere. Find the radius of small sphere.





[Watch Video Solution](#)

53. A lead pencil consists of a cylinder of wood with a solid cylinder of graphite filled in the interior. The diameter of the pencil is 7 mm and the diameter of the graphite is 1 mm. If the length of the pencil is 14 cm, find the volume of the wood



[Watch Video Solution](#)

54. Find

(i) the lateral or curved surface area of a closed cylindrical petrol storage tank that is 4.2 m in diameter and 4.5 m high.

(ii) how much steel was actually used, if $\frac{1}{12}$ of the steel actually used was wasted in making the tank



Watch Video Solution

55. A conical vessel of radius 6 cm and height 8 cm is completely filled with water. A sphere is lowered into the water and its size is such that when it touches the sides it is just immersed. What fraction of water overflows ?



Watch Video Solution

56. about to only mathematics



Watch Video Solution

57. In one fortnight of a given month, there was a rainfall of 10 cm in a river valley. If the area of the valley is 97280 km^2 , show that the total rainfall was approximately equivalent to the addition to the normal water of three rivers each 1072 km long, 75 m wide and 3m deep



Watch Video Solution

58. A cone of radius 8 cm and height 12 cm is divided into two parts by a plane through the

mid-point of its axis parallel to its base. Find the ratio of the volumes of two parts.



[Watch Video Solution](#)

59. The height of a right circular cone is trisected by two planes drawn parallel to the base. Show that the volumes of the three portions starting from the top are in the ratio 1:7:19.



[Watch Video Solution](#)

60. The radii of the faces of a frustum of a cone are 3 cm and 4 cm and its height is 5 cm find its volumen.



[Watch Video Solution](#)

61. The height of a cone is 30 cm. A small cone is cut off at the top by a plane parallel to the base. If its volume be $\frac{1}{27}$ of the volume of the given cone, at what height above the base is the section made?



[Watch Video Solution](#)

62. The radii of the ends of a bucket 30 cm high are 21 cm and 7 cm. Find its capacity in litres and the amount of sheet required to make this bucket.



Watch Video Solution

63. A bucket is 32 cm in diameter at the top and 20 cm in diameter at the bottom. Find the capacity of bucket in litres if it is 21 cm deep.

Also find the cost of tin sheet used in making the bucket at the rate of Rs 1.50 per sq dm.



[Watch Video Solution](#)

64. Find the volume and whole surface of frustum of a square pyramid , thje sides of whose base and top are 24 cm and 16 cm respectively and each of the edges of the frustum is 20cm.



[View Text Solution](#)

Problems From Ncert Exemplar

1. From a solid cylinder whose height is 2.4 cm and diameter 1.4 cm, a conical cavity of the same height and same diameter is hollowed out. Find the total surface area of the remaining solid to the nearest cm^2



[Watch Video Solution](#)

2. Shubham pal an engineering student was asked to make a model shaped like cylinder

wih two cones attached at its two ends by using a thin aluminium sheet. The diameter of the model is 3 cm and its length is 12 cm .If each cone has a height of 32 cm , find the volufme of air contained in the model that shubham pal made. (Assume the outer and inner dimensions of the model to be nearly the same).



Watch Video Solution

3. A gulab jamun, contains sugar syrup up to about 30% of its volume. Find approximately how much syrup would be found in 45 gulab jamuns, each shaped like a cylinder with two hemispherical ends with length 5 cm and diameter 2.8 cm.



[Watch Video Solution](#)

4. A solid iron pole consists of a cylinder of height 220 cm and base diameter 24 cm, which

is surmounted by another cylinder of height 60 cm and radius 8 cm. Find the mass of the pole, given that 1 cm^3 of iron has approximately 8g mass.



[Watch Video Solution](#)

5. A spherical glass vessel has a cylindrical neck 8 cm long, 2 cm in diameter; the diameter of the spherical part is 8.5 cm. By measuring the amount of water it holds, a child finds its volume to be 345 cm^3 . Check whether she is

correct, taking the above as the inside measurements.



[Watch Video Solution](#)

6. A well of diameter 3 m is dug 14 m deep. The earth taken out of it has been spread evenly all around it in the shape of a circular ring of width 4 m to form an embankment. Find the height of the embankment.



[Watch Video Solution](#)

7. An oil funnel of tin sheet consists of a cylindrical portion 10 cm long attached to a frustum of a cone. If the total height be 22 cm, the diameter of the cylindrical portion 8 cm and the diameter of the top of the funnel 18 cm, find the area of the tin required. (Use $\pi = 22/7$)



[Watch Video Solution](#)

8. Shanti Sweets Stall was placing an order for making cardboard boxes for packing their

sweets. Two sizes of boxes were required. The bigger of dimensions $25\text{ cm} \times 20\text{ cm} \times 5\text{ cm}$ and the smaller of dimensions $15\text{ cm} \times \dots$



[Watch Video Solution](#)

9. In one fortnight of a given month, there was a rainfall of 10cm in a river valley. If the area of the valley is 7280 km^2 . show that the total rainfall was approximately equivalent to the

addition to the normal water of three rivers each 1072 km long, 75 m wide and 3 m deep.



[Watch Video Solution](#)

10. The slant height of the frustum of a cone is 4 cm and the perimeters of its circular ends are 18 cm and 6 cm. Find the curved surface of the frustum.



[Watch Video Solution](#)

Exercise

1. A solid is in the form of a cone standing on a hemisphere with both their radii being equal to 8 cm and the height of cone is equal to its radius . Find the volume of solid.



[Watch Video Solution](#)

2. The following figure shows a model of rocket consisting of a cylinder surmounted by a cone at one end . The dimensions of the

model are radius = 3 cm and height of the cone = 4 cm and total height = 14 cm. Find the (i) total surface area of the model in πm^2 (ii) the total volume of model in πm^3 .

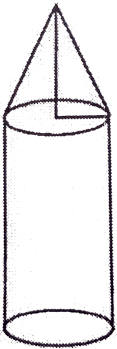

[Watch Video Solution](#)

3. Two cubes with each side 10 cm are joined are joined end to end . Find the total surface

area of the resulting cuboid.



[Watch Video Solution](#)

4. Three equal cubes are placed adjacently in a row. Find the ratio of the total surface area of the resulting cuboid to that of the sum of the total surface areas of the three cubes.



[Watch Video Solution](#)

5. Four identical cubes are joined end to end to form a cuboid .If the total surface area of the resulting cuboid is 648 cm^2 .Find the length of edge of each cube.



[Watch Video Solution](#)

6. The given figure shows a solid formed of a solid cube of side 40 cm and a solid cylinder of radius 20 cm and height 50 cm attached to the cube as shown. Find the volume and the

total surface area of the whole solid [Take

$$\pi = 3.14]$$

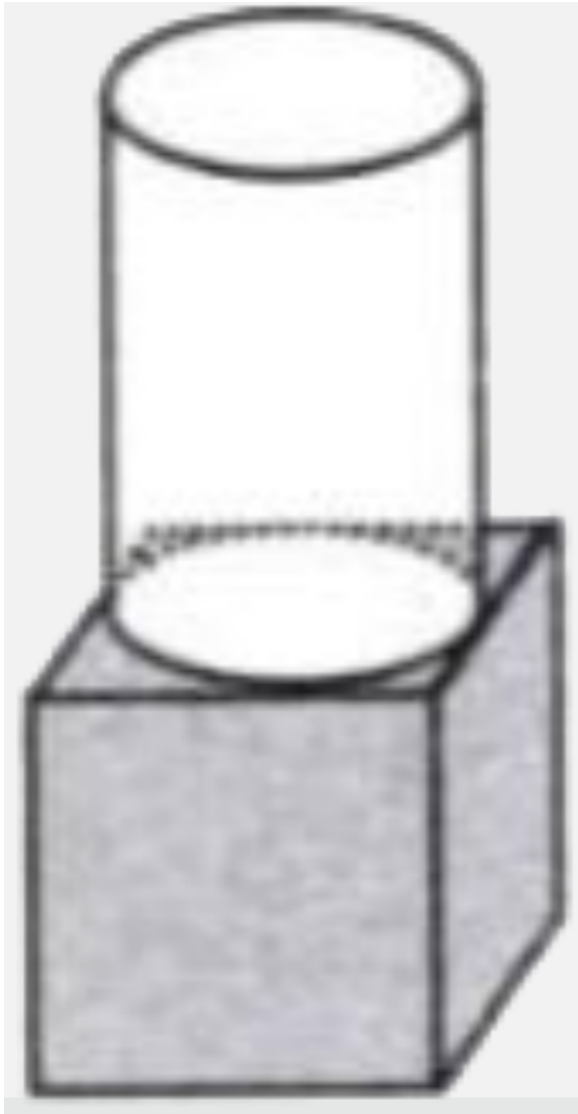

[Watch Video Solution](#)

7. A circus tent is in the form of a right circular cylinder and right circular cone above it. The diameter and the height of the cylindrical part of the tent are 126 m and 5 m respectively. The total height of the tent is 21 m. Find the total cost of the tent if the canvas used costs Rs 12 per square metre.



[Watch Video Solution](#)

8. An exhibition tent is in the form of a cylinder surmounted by a cone. The height of the tent above the ground is 85 m and height of the cylindrical part is 50 m. If the diameter of the base is 168 m, find the quantity of canvas required to make the tent. Allow 20% extra for fold and for stitching. Give your answer to the nearest m^2 .



[Watch Video Solution](#)

9. A pen stand made of wood is in the shape of a cuboid with four conical depressions to hold pens. The dimensions of the cuboid are 15 cm by 10 cm by 3.5 cm. The radius of each of the depressions is 0.5 cm and the depth is 1.4 cm. Find the volume of wood in the entire stand.



Watch Video Solution

10. A solid consisting of a right circular cone, standing on a hemisphere, is placed upright,

in a right circular cylinder, full of water, and touches the bottom. Find the volume of water left in the cylinder, having given that the radius of the cylinder is 3 cm and its height is 6 cm, the radius of the hemisphere is 2 cm and the height of the cone is 4 cm. Give your answer correct to the nearest centimetre

$$\left(\text{Take } \pi = 3\frac{1}{7} \right)$$



Watch Video Solution

11. An iron pillar has some part in the form of a right circular cylinder and remaining in the form of a right circular cone. The radius of the base of each of cone and cylinder is 8 cm. The cylindrical part is 240 cm high and the conical part is 36 cm high. Find the weight of the pillar if one cubic cm of iron weighs 7.8 grams.



Watch Video Solution

12. A solid is in the form of a cylinder with hemispherical ends. Total height of the solid is 19 cm and the diameter of the cylinder is 7 cm. Find the volume and total surface area of the solid.



Watch Video Solution

13. A right cylinder , a right cone and a hemishpere have the same heightr and sthe

same base area .Find the ratio of their (i) volumes (ii) total surface areas.



[Watch Video Solution](#)

14. From a circular cylinder of diameter 10 cm and height 12 cm a conical cavity of the same base radius and of the same height is hollowed out. Find the volume and the whole surface of the remaining solid .Leave the answer in π .



[Watch Video Solution](#)

15. The height of a solid cylinder is 15 cm. and the diameter of its base is 7 cm. Two equal conical holes each of radius 3 cm, and height 4 cm are cut off. Find the volume of the remaining solid.



Watch Video Solution

16. Find the volume of the largest right circular cone that can be cut out of a cube whose edge is 9cm.



[Watch Video Solution](#)

17. From a rectangular solid of metal 42 cm by 30 cm by 20 cm, a conical cavity of diameter 14 cm and depth 24 cm is drilled out. Find :
the weight of the material drilled out if it weighs 7 gm per cm^3 .



[Watch Video Solution](#)

18. A wooden toy is in the shape of a cone mounted on a cylinder as shown alongside. If the height of the cone is 24 cm, the total height of the toy is 60 cm, and the radius of the base of the cone = twice the radius of the base of the cylinder = 10 cm. Find the total

surface area of the you.

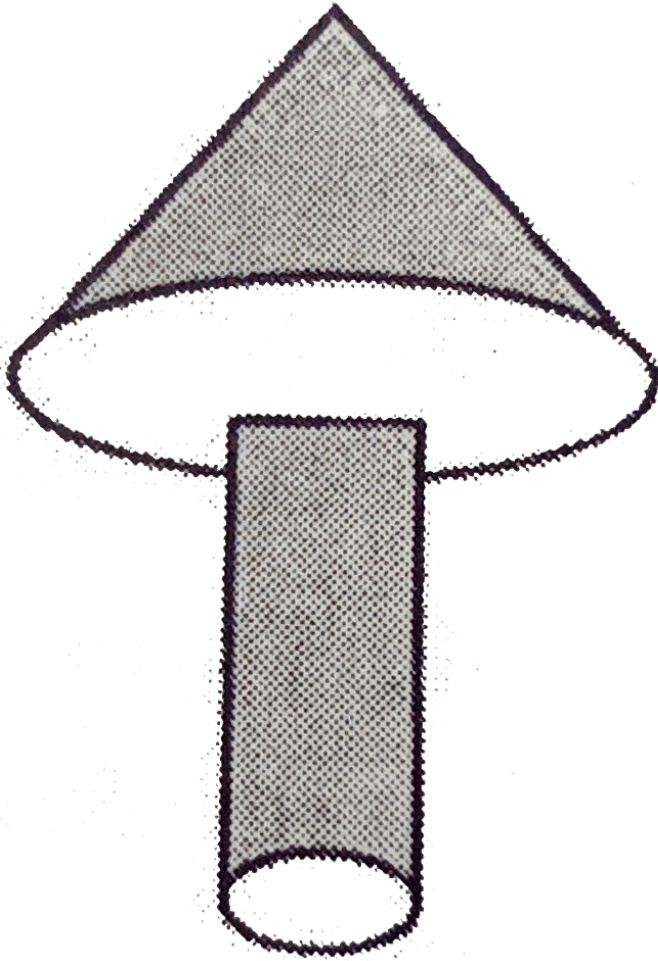

Watch Video Solution

19. A sphere just fits in a cylindrical vessel and the height of the cylindrical vessel is the same as the height of the sphere . Show that the curved surface area of the cylinder is the same as the curved surface area of the sphere .



Watch Video Solution

20. A room in the form of a cylinder surmounted by a hemisphere valuted dome contains 17.7 m^3 .After recycling, this water is

used to irrigate a park of hospital whose length is 25 m and breadth is 20 m. If tank is filled completely then what will be the height of standing water used for irrigating the park write you views on recycling of water.



[Watch Video Solution](#)

21. In a hospital used water is collected in a cylindrical tank of diameter 2 m and hight 5 m. After recycling this water is used to irrigate a park of hospital whose length is 25 m and

breadth is 20 m. If tank is filled completely then what will be the height of standing water used for irrigating the park.



[Watch Video Solution](#)

22. Three metal cubes with edges 6cm , 8cm and 10cm respectively are melted together and formed in to a single cube. Find the diagonal of this cube.



[Watch Video Solution](#)

23. Six cubes each of side 12 cm are joined end to end .Find the surface area of the cuboid so formed .



Watch Video Solution

24. 2 cubes each of volume 64 cm^3 are joined end to end. Find the surface area of the resulting cuboid.



Watch Video Solution

25. 40 circular plates each of radius 7 cm and thickness 1.5 cm are placed one above the other to form a solid right circular cylinder. Find the total surface area and volume of cylinder so formed.



Watch Video Solution

26. A right circular cone is 8 cm high and radius of its base is 2 cm .The cone is melted and recast into a sphere. Determine the diameter of the sphere.



[Watch Video Solution](#)

27. A girl fills a cylindrical bucket 32 cm in height and 18 cm in radius with sand. She empties the bucket on the ground and makes a conical heap of the sand. If the height of the conical heap is 24 cm, find :

(i) the radius and

(ii) the slant height of the heap. Give your answer correct to one place of decimal.



[Watch Video Solution](#)

28. The volume of a sphere is $\frac{4\pi}{3} cm^3$. Find the volume of that cube whose edge is equal to the diameter of the sphere.



[Watch Video Solution](#)

29. A cone of height 4 cm is melted and recast into a sphere of diameter 8 cm. Find the radius of the base of the cone.



[Watch Video Solution](#)

30. A metallic sphere of radius 7 cm is melted and recast into a right circular cone of same radius. Find the height of the cone.



Watch Video Solution

31. The height and base radius of a metallic cone are 216 cm and 16 cm respectively. It is melted and recast into a sphere. Find the surface area of the sphere.



Watch Video Solution

32. The base diameter and height of a metallic cone are 24cm and 6cm respectively .It is melted and recast in to a sphere.Find the surface area of the sphere.



Watch Video Solution

33. (a) Three metallic spherical balls of radii 3 cm , 4cm and 5 cm are melted and recast in to a big spherical ball find the radius of this big ball.

(b) Three metallic spheres are melted and recast into a big solid sphere. Find the radius of big solid sphere if the diameters of three metallic spheres are 16 cm, 12 cm and 2 cm.



[Watch Video Solution](#)

34. (a) How many balls of radius 1 cm can be drawn by melting metallic sphere of radius 3 cm?

(b) The small spherical balls of diameter 0.6 cm are drawn by melting solid metallic sphere of

3cm radius .Find the number of small balls constructed.



[Watch Video Solution](#)

35. (a) How many spherical balls of diameter 12 cm can be constructed by melting a metallic cylinder of diameter 8cm and height 90 cm?

(b) How many spherical balls of diameter 12 cm can be constructed by melting a metallic cylinder of radius 4 cm and height 72 cm.



[Watch Video Solution](#)

36. A metallic sphere of radius 4 cm and a metallic cone of base radius 3 cm and height 6 cm are melted and recast a cylinder of 5 cm radius. Find the height of the cylinder.



Watch Video Solution

37. How many solid spherical balls of radius 3.5 cm can be recast by melting a metallic cone of height 35 cm and base radius 7 cm?



Watch Video Solution

38. There is some water in a cylindrical vessel of radius 6 cm a sphere of radius 2 cm is dropped in to the vessel .Find the increase in the height of water surface.



Watch Video Solution

39. A solid metallic ball is dropped in a cylindrical vessel which has some waater .when this ball is fully immersed in water the water

surface rises by 2 cm find the volume of ball if the radius of base of cylindrical vessel is 7cm.



[Watch Video Solution](#)

40. (i) The radius of a metallic sphere is 3 cm .It melted and recast in to wire of diameter 0.4 cm Find the length of wire.

(ii) An iron ball oif radius 4 cm is melted .How many small spheres of radus 2 cm can be formed from the material?



[Watch Video Solution](#)

41. How many metallic cones of radius 3 cm and height 13.5 cm are required to construct a metallic sphere of radius 4.5 cm?



Watch Video Solution

42. The inner radius of a hemispherical cup is 9 cm and it is completely full of water. This water is filled in cylindrical bottles of diameter 3cm and height 4 cm Find the number of bottles required.



[Watch Video Solution](#)

43. Two metallic cones of equal radii 2.1 cm and heights 4.1 cm and 4.3 cm are melted together and recast a sphere. Find the radius of sphere so formed.



[Watch Video Solution](#)

44. Three metallic cones of radius 2cm and height 9cm are melted and recast in to a solid

sphere. Find the radius of the sphere.



[Watch Video Solution](#)

45. Three metallic cones of radius 2cm and height 9 cm are melted and recast into a solid sphere. Find the radius of the sphere.



[Watch Video Solution](#)

46. A metallic cone is melted and recast into a cylinder of same radius and height 9 cm. Find

the height of the cone.



[Watch Video Solution](#)

47. A cone of height 15 cm is melted and recast in to cylinder of same base .Find the height of the cylinder.



[Watch Video Solution](#)

48. A cone of same height and same base radius is cut from a cylinder of height 8 cm

and base radius 6 cm .Find the total surface area and volume of the remaining solid.



[Watch Video Solution](#)

49. The heights of two cones are same and equal to 6cm .Their radii are 4cm and 3cm .They are melted and recast in to a cylinder of base radius 5cm.Find the height of this cylinder.



[Watch Video Solution](#)

50. Find the volume of a cube whose diagonal is 17.32 metre.



Watch Video Solution

51. The radius of a spherical ball of iron is 1.5 cm. It is melted and recast into three spherical balls. If the radii of two such balls are 0.75 cm and 1 cm, then find the radius of 3rd ball.



Watch Video Solution

52. Water is being pumped out through a circular pipe whose internal diameter is 7 cm. If the flow of water is 72 cm per second, how many litres of water are being pumped out in one hour?



Watch Video Solution

53. A hemispherical tank of radius 1.75 m is full of water. It is connected with a pipe which empties it at the rate of 7 litres per second.

How much time will it take to empty the tank completely?



[Watch Video Solution](#)

54. The curved surface of a cylinder is 100 sq cm . A wire of diameter 5 mm is wound round it so as to cover it completely. Find the length of the wire.



[Watch Video Solution](#)

55. How many square metres of canvas will be required to make a conical tent 8 metre high and base radius is 6 m



[Watch Video Solution](#)

56. A rectangular sheet of tin $58\text{ cm} \times 44\text{ cm}$ is to be made into an open box by cutting off equal squares from the corners and folding up the flaps. What should be the volume of box if the surface area of box is 2452 cm^2 ?





[Watch Video Solution](#)

57. A solid metallic right circular cone of height 30cm and radius of the base 12 cm is melted and two solid spheres formed from it. If the volume of one of the sphere is 8 times that of the other find the radius of the smaller sphere.



[Watch Video Solution](#)

58. One cubic metre of a certain metal weighing 900 Kg is melted and then rolled in to a bar whose cross section is a square and whose length is 9 meter .An exact cube is cut off from it . Find the weight of this cube.



Watch Video Solution

59. about to only mathematics



Watch Video Solution

60. A solid metal sphere is melted and smaller spheres of equal radii are formed. 10% of the volume of the sphere is lost in the process. The smaller spheres have a radius, that is $\frac{1}{9}$ th the larger sphere. If 10 litres of paint were needed to paint the larger sphere. Find how many litres are needed to paint all the smaller spheres?



Watch Video Solution

61. The radius of the ends of a bucket of height 24 cm are 15 cm and 5 cm. Find its capacity .Also find the surface area of the bucket .



Watch Video Solution

62. The radii of the ends of a frustum of a cone 45 cm high are 28 cm and 7 cm. Find its volume, the curved surface area and the total surface area.



Watch Video Solution

63. A bucket is made of chart paper in the form of cone open at both ends. The radii of its ends are 16 cm and 24 cm and its height is 6 cm .Find the cost of the paper used if one square metre of paper costsRs 0.70.



Watch Video Solution

64. A wooden right circular cone has a base of radius 3 cm and height 4 cm .The upper part of the cone is cut in such a way that the

conical piece will have height 1 cm and base radius 0.75 cm .Find the volume of the remaining portion.



[Watch Video Solution](#)

65. The lower portion of a haystack is an inverted cone frustum and upper part is a cone as shown in figure .Find the total volume of haystack if $AB = 3$ m and $CD = 2$ m height of

cone = 7 m and height of haystack = 10.5 m

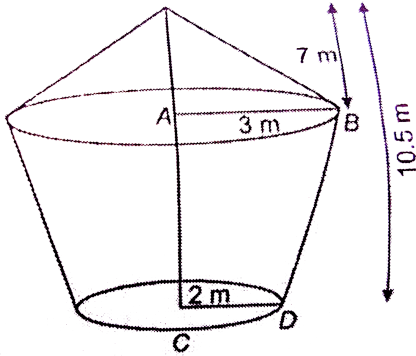

[Watch Video Solution](#)

66. A Hollow cone is cut by a plane parallel to the base and upper portion is removed. If the curved surface of the remainder is $\frac{8}{9}$ of the curved surface of the whole cone; find the

ratio of the line-segment into which the cone's altitude is divided by the plane.



[Watch Video Solution](#)

67. A metallic right circular cone 20 cm high and whose vertical angle is 90° is cut into two parts at the middle point of its axis by a plane parallel to the base. If the frustum so obtained be drawn into a wire of diameter $(1/16)$ cm, find the length of the wire.



[Watch Video Solution](#)

68. The radius of the base of a right circular cone is r . It is cut by a plane parallel to the base at a height h from the base. The distance of the boundary of the upper surface from the centre of the base of the frustum is

$\sqrt{h^2 + \frac{4^2}{9}}$. Show that the volume of the frustum is $\frac{13}{27}\pi r^2 h$.



Watch Video Solution

1. A metallic solid sphere of radius 9 cm is melted to form a solid cylinder of radius 9 cm. Find the height of the cylinder.



[Watch Video Solution](#)

2. The surface area of two spheres are in the ratio 16:9 .Find the ratio of their volumes.



[Watch Video Solution](#)

3. If the radius of a sphere becomes 3 times then how many times will its volume be?



[Watch Video Solution](#)

4. If the radius of two circular ends of a basket are $5/2$ cm and 1 cm respectively and its height is 6 cm then find the slant height of frustum.



[Watch Video Solution](#)

5. 20 circular plates each of radius 5 cm and thickness 10 mm are placed one above another. What is the shape of solid made and find its height?



Watch Video Solution

6. 2 cubes, each of volume 125 cm^3 , are joined end to end . Find the surface area of the resulting cuboid.



Watch Video Solution

7. A vessel is in the form of hemispherical bowl mounted by a hollow cylinder. If the height of cylinder is 6cm and radius is 7 cm .Find the total height of the vessel.



[Watch Video Solution](#)

8. A bucket in the shape of frustum is closed from both ends .If its radii are R and r respectively and height h and slant height l . Write the formula of its total surface area.





[Watch Video Solution](#)

9. A cubic cm of gold is drawn into a wire 0.1 mm in diameter, find the length of the wire.



[Watch Video Solution](#)

10. Three solid spheres of radii 3, 4 and 5 cm respectively are melted and converted into a single solid sphere. Find the radius of this sphere.



[Watch Video Solution](#)

Revisions Exercise Short Answer Questions

1. A cylindrical bucket 28 cm in diameter and 72 cm high is full of water. The water is emptied into a rectangular tank 66 cm long and 28 cm wide. Find the height of the water level in the tank.



Watch Video Solution

2. How many balls, each of radius 1 cm, can be made from a solid sphere of lead of radius 8 cm?



[Watch Video Solution](#)

3. A metallic sphere of radius 10.5 cm is melted and thus recast into small cones, each of radius 3.5cm and height 3cm. Find how many cones are obtained.



[Watch Video Solution](#)

4. A cone and a hemisphere have equal bases and equal volumes. Find the ratio of their heights.



[Watch Video Solution](#)

5. A cube is inscribed in a sphere of diameter 'd' cm. What is the side of the largest cube so inscribed?



[Watch Video Solution](#)

6. A spherical ball of lead has been melted and made in to smaller balls of half the radius of the original one. How many balls can be made?



[Watch Video Solution](#)

7. A toy is in the form of a cone of radius 3.5 cm mounted on a hemisphere of same radius. The total height of the toy is 15.5 cm. Find the total surface area of the toy.



[Watch Video Solution](#)

8. about to only mathematics



[Watch Video Solution](#)

9. The ratio between the radius of the base of height of a cylinder is 2:3. If its volume is 1617 cm^3 , find the total surface area of the cylinder.



[Watch Video Solution](#)

10. A hemispherical tank full of water is emptied by a pipe at the rate of $\frac{25}{7}$ litres per second. How much time will it take to empty half the tank, if it is 3m in diameter?



[Watch Video Solution](#)

Revisions Exercise Long Answer Questions

1. A wooden toy rocket is in the shape of a cone mounted on a cylinder. The height of the entire rocket is 26 cm, while the height of the

conical part is 6 cm. The base of the conical portion has a diameter of 5 cm, while the base diameter of the cy



[Watch Video Solution](#)

2. Two spheres of same metal weight 1 kg and 7 kg .The radius of the smaller sphere is 3cm .The two spheres are melted to form a single big sphere.Find the diameter of the new sphere.



[Watch Video Solution](#)

3. Water running in a cylindrical pipe of inner diameter 7 cm, is collected in a container at the rate of 192.5 litres per minute. Find the rate flow of water in the pipe in km/hr.



[Watch Video Solution](#)

4. An open metal bucket is in the shape of a frustum of a cone, mounted on a hollow cylindrical base made of the same metallic sheet. The diameters of the two circular ends

of the bucket are 45 cm and 25 cm, the total vertical height of the bucket is



[Watch Video Solution](#)

5. An oil funnel of tin sheet consists of a cylindrical portion 10 cm long attached to a frustum of a cone. If the total height be 22 cm, diameter of the cylindrical portion be 8 cm and the diameter of the top of the funnel be 18 cm, find the area of the tin required to make the funnel.



Watch Video Solution