



MATHS

BOOKS - SELINA MATHS (ENGLISH)

CYLINDER, CONE AND SPHERE

Questions

1. The area of the curved surface of a cylinder is $4,400\text{cm}^2$ and the circumference of its base is 110 cm. Find :

(i) the height of the cylinder,

(ii) the volume of the cylinder.



Watch Video Solution

2. 50 identical circular plates are placed one above the other to form a solid cylinder. For each plate, diameter = 21 cm and thickness = 15 cm. Find :

(i) curved surface area of the cylinder formed.

(ii) volume of the cylinder fomred.



Watch Video Solution

3. The volume of a solid cylinder is 96228cm^3 and the ratio of its radius to its height is 9:14. Find the total surface area of the cylinder.



[Watch Video Solution](#)

4. A cylindrical tube, open at both ends, is made of metal. The internal diameter of the tube is 112 cm and its length is 21 cm. The metal everywhere is 0.4 cm in thickness.

Calculate the volume of the metal correct to one place of decimal.



Watch Video Solution

5. Find the volume of the largest cylinder formed when a rectangular piece of paper 22 cm by 15 cm is rolled along its longer side.



Watch Video Solution

6. When a metal cube is completely submerged in water contained in a cylindrical vessel with diameter 30 cm, the level of water rises by $1\frac{41}{99}$ cm. Find :

(i) the length of edge of the cube.

(ii) the total surface area of the cube.



Watch Video Solution

7. The radius of the base and the height of a right circular cone are 7 cm and 24 cm

respectively. Find the volume and the total surface area of the cone.



[Watch Video Solution](#)

8. A right circular cone is 3.6 cm high and radius of its base is 1.6 cm. It is melted and recast into a right circular cone with radius of its base as 1.2 cm. Find its height.



[Watch Video Solution](#)

9. The ratio of the base area and the curved surface area of a conical tent is 40:41. If its height is 18 m, find the air capacity of the tent in terms of π .



Watch Video Solution

10. Find what length of canvas, 2 m in width, is required to make a conical tent 12 m in diameter and 63 m in slant height?

Also, find the cost of the canvas at the rate of Rs. 150 per metre.



[Watch Video Solution](#)

11. A vessel, in the form of an inverted cone, is filled with water to the brim. Its height is 20 cm and diameter is 16.8 cm. Two equal solid cones are dropped in it so that they are fully submerged. As a result, one-third of the water in the original cone overflows. What is the

volume of each of the solid cones submerged

?



[Watch Video Solution](#)

12. Find the area of the canvas required to make a conical tent 14 m high and 96 m in diameter. Given that:

(i) 20% of the canvas is used in folds and stitchings.

(ii) canvas used in folds and stitchings is 20% of the curved surface area of the tent.



[Watch Video Solution](#)

13. The capacity and the base area of a right circular conical vessel are 9856 cm^3 and 616 cm^2 respectively. Find the curved surface area of the vessel.



[Watch Video Solution](#)

14. If the surface area of a sphere is 616 cm^2 , find its volume.



[Watch Video Solution](#)

15. The internal and external diameters of a hollow hemispherical vessel are 42 cm and 45 cm respectively. Find its capacity and also its outer curved surface area.



Watch Video Solution

16. A solid spherical ball of iron with radius 6 cm is melted and recast into three solid spherical balls. The radii of the two balls are 3

cm and 4 cm respectively, determine the diameter of the third ball.



[Watch Video Solution](#)

17. The internal and external diameters of a hollow hemispherical vessel are 21 cm and 25.2 cm respectively. Find the cost of painting it, all over, at the rate of 1.50 per cm^2 .



[Watch Video Solution](#)

18. The radius of the base of a cone and the radius of a sphere are the same, each being 8 cm. Given that the volumes of these two solids are also the same, calculate the slant height of the cone.



Watch Video Solution

19. A metallic sphere of radius 10.5 cm is melted and then recast into small cones each

of radius 3.5 cm and height 3 cm. Find the number of cones thus formed.



[Watch Video Solution](#)

20. A hollow metal sphere of internal and external radii 2 cm and 4 cm respectively is melted into a solid cone of base radius 4 cm. Find the height and slant height of the cone.



[Watch Video Solution](#)

21. A vessel is in the form of an inverted cone. Its height is 11 cm and the radius of its top, which is open, is 2.5 cm. It is filled with water up to the rim. When lead shots, each of which is a sphere of radius 0.25 cm, are dropped into the vessel $\frac{2}{5}$ of the water flows out. Find the number of lead shots dropped into the vessel.



Watch Video Solution

22. A toy is in the form of a cone mounted on a hemisphere with the same radius. The diameter of the base of the conical portion is 12 cm and its height is 8 cm. Determine the surface area and the volume of the toy ($\pi = 3.14$).



Watch Video Solution

23. The given block is made of two solids : a cone and a hemisphere. If the height and the

base-radius of the cone are 24 cm and 10 cm respectively and the diameter of the hemisphere is 10 cm, find the total surface area of the block. (Take $\pi = 3.14$)



[Watch Video Solution](#)

24. The height of a solid cone is 30 cm. A small cone is cut off from the top of it such that the base of the cone cut off and the base of the given cone are parallel to each other. If the

volume of the cone cut and the volume of the original cone are in the ratio 1:27, find the height of the the remaining part of the given cone.



[Watch Video Solution](#)

25. The given figure shows the cross-section of an ice cream cone consisting of a cone surmounted by a hemisphere. The radius of the hemisphere is 3.5 cm and the height of the cone is 10.5 cm. The outer shell ABCDEF is

shaded and is not filled with ice-cream. $AF = DC = 0.5$ cm, $AB \parallel FE$ and $BC \parallel ED$. Calculate :

(i) the volume of the ice-cream in the cone (the internal volume of the cone including the hemisphere) in cm^3 ,

(ii) the volume of the outer shell (the shaded portion) in cm^3 .

In each case, give your answer correct to the

nearest cm^3 .

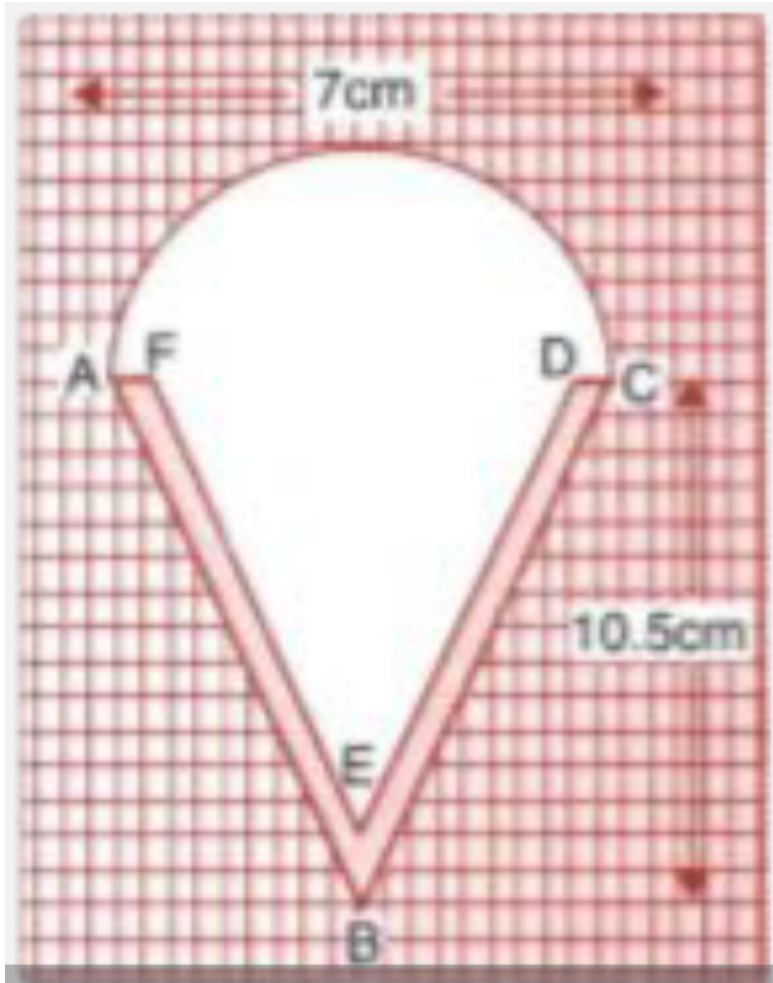

Watch Video Solution

26. From a solid cylinder of height 36 cm and radius 14 cm, a conical cavity of radius 7 cm and height 24 cm is drilled out. Find the volume and the total surface area of the remaining solid.



Watch Video Solution

27. A girl fills a cylindrical bucket 32 cm in height and 18 cm in radius with sand. She empties the bucket on the ground and makes

a conical heap of the sand. If the height of the conical heap is 24 cm, find :

(i) the radius and

(ii) the slant height of the heap. Give your answer correct to one place of decimal.



[Watch Video Solution](#)

28. From a solid cylinder, whose height is 8 cm and radius is 6 cm, a conical cavity of height 8 cm and of base radius 6 cm is hollowed out. Find the volume of the remaining solid.



[Watch Video Solution](#)

29. A cylindrical beaker, whose base has a radius of 15 cm, is filled with water up to a height of 20 cm. A heavy iron spherical ball of radius 10 cm is dropped to submerge completely in water in the beaker. Find the increase in the level of water.



[Watch Video Solution](#)

30. The cross-section of a railway tunnel is a square surmounted by a semi-circle as shown in the figure.

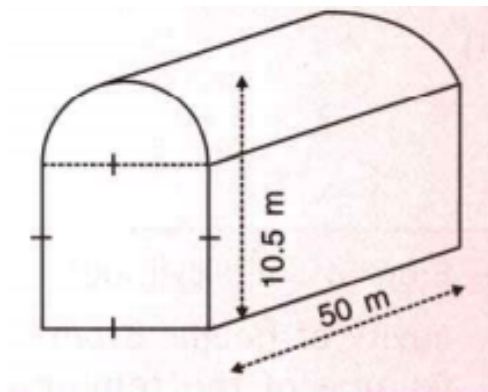

The tunnel is 50 m long. Find the cost of plastering the internal surface of the tunnel (excluding the floor) at the rate of Rs 10 per m^2 .



[Watch Video Solution](#)

31. Water flows through a cylindrical pipe of internal diameter 7 cm at 5 metre per second.

Calculate :

(i) the volume, in litres, of water discharged by the pipe in one minute,

(ii) the time, in minutes, the pipe would take to fill an empty rectangular tank $4m \times 3m \times 2.31m$.



[Watch Video Solution](#)

Exercise 20 A

1. The height of a circular cylinder is 20 cm and the radius of its base is 7 cm. Find :
the volume



[Watch Video Solution](#)

2. The height of a circular cylinder is 20 cm and the radius of its base is 7 cm. Find :
the total surface area.



[Watch Video Solution](#)

3. The inner radius of a pipe is 2.1 cm. How much water can 12 m of this pipe hold ?



[Watch Video Solution](#)

4. A cylinder of circumference 8 cm and length 21 cm rolls without sliding for $4\frac{1}{2}$ seconds at the rate of 9 complete rounds per second. Find :

the distance travelled by the cylinder in $4\frac{1}{2}$ seconds ?



[Watch Video Solution](#)

5. A cylinder of circumference 8 cm and length 21 cm rolls without sliding for $4\frac{1}{2}$ seconds at the rate of 9 complete rounds per second.

Find :

the area covered by the cylinder in $4\frac{1}{2}$ seconds.



[Watch Video Solution](#)

6. How many cubic metres of earth must be dug out to make a well 28 m deep and 2.8 m in diameter ? Also, find the cost of plastering its inner surface at Rs 4.50 per sq. metre.



[Watch Video Solution](#)

7. What length of solid cylinder 2 cm in diameter must be taken to recast into a hollow cylinder of external diameter 20 cm, 0-25 cm thick and 15 cm long?



[Watch Video Solution](#)

8. A cylinder has a diameter of 20 cm. The area of the curved surface is 100 sq cm. Find the height of the cylinder correct to one decimal place.



[Watch Video Solution](#)

9. A cylinder has a diameter of 20 cm. The area of the curved surface is 100 cm^2 . Find the

volume of the cylinder (in. cm^3).



Watch Video Solution

10. A metal pipe has a bore (inner diameter) of 5 cm. The pipe is 5 mm thick all round. Find the weight, in kilogram, of 2 metres of the pipe if $1cm^3$ of the metal weighs 7.7 g.



Watch Video Solution

11. A cylindrical container with diameter of base 42 cm contains sufficient water to submerge a rectangular solid of iron with dimensions $22\text{cm} \times 14\text{cm} \times 10.5\text{cm}$. Find the rise in level of the water when the solid is submerged.



Watch Video Solution

12. A cylindrical container with internal radius of its base 10 cm, contains water up to a

height of 7 cm. Find the area of the wet surface of the cylinder.



[Watch Video Solution](#)

13. Find the total surface area of an open pipe of length 50 cm, external diameter 20 cm and internal diameter 6 cm.



[Watch Video Solution](#)

14. The height and the radius of the base of a cylinder are in the ratio 3: 1. If its volume is $1029 \pi \text{cm}^3$, find its total surface area.



[Watch Video Solution](#)

15. The radius of a solid right circular cylinder increases by 20% and its height decreases by 20%. Find the percentage change in its volume.



[Watch Video Solution](#)

16. The radius of a solid right circular cylinder decreases by 20% and its height increases by 10%. Find the percentage change in its :
volume



Watch Video Solution

17. The radius of a solid right circular cylinder decreases by 20% and its height increases by 10%. Find the percentage change in its :
curved surface area



[Watch Video Solution](#)

18. Find the minimum length in cm and correct to nearest whole number of the thin metal sheet required to make a hollow and closed cylindrical box of diameter 20 cm and height 35 cm. Given that the width of the metal sheet is 1 m. Also, find the cost of the sheet at the rate of Rs 56 per sq m.

Find the area of metal sheet required, if 10% of it is wasted in cutting, overlapping, etc.



[Watch Video Solution](#)

19. 3080 cm^3 of water is required to fill a cylindrical vessel completely and 2310 cm^3 of water is required to fill it upto 5 cm below the top. Find :
radius of the vessel.



[Watch Video Solution](#)

20. 3080 cm^3 of water is required to fill a cylindrical vessel completely and 2310 cm^3 of

water is required to fill it upto 5 cm below the top. Find :
height of the vessel.



[Watch Video Solution](#)

21. 3080 cm^3 of water is required to fill a cylindrical vessel completely and 2310 cm^3 of water is required to fill it upto 5 cm below the top. Find :
wetted surface area of the vessel when it is half-filled with water.



[Watch Video Solution](#)

22. Find the volume of the largest cylinder formed when a rectangular piece of paper 44 cm by 33 cm is rolled along its shorter side.



[Watch Video Solution](#)

23. Find the volume of the largest cylinder formed when a rectangular piece of paper 44 cm by 33 cm is rolled along its longer side.



[Watch Video Solution](#)

24. A metal cube of side 11 cm is completely submerged in water contained in a cylindrical vessel with diameter 28 cm. Find the rise in the level of water.



Watch Video Solution

25. A circular tank of diameter 2 m is dug and the earth removed is spread uniformly all around the tank to form an embankment 2 m

in width and 1.6 m in height. Find the depth of the circular tank.



[Watch Video Solution](#)

26. The sum of the inner and the outer curved surfaces of a hollow metallic cylinder is 1056cm^2 and the volume of material in it is 1056cm^3 . Find its internal and external radii. Given that the height of the cylinder is 21 cm.



[Watch Video Solution](#)

27. The difference between the outer curved surface area and the inner curved surface area of a hollow cylinder is 352cm^2 . If its height is 28 cm and the volume of material in it is 704cm^3 , find its external curved surface area.



Watch Video Solution

28. The sum of the height and the radius of a solid cylinder is 35 cm and its total surface area is 3080cm^2 , find the volume of the cylinder.



[Watch Video Solution](#)

29. The total surface area of a solid cylinder is 616cm^2 . If the ratio between its curved surface area and total surface area is $1 : 2$, find the volume of the cylinder.



[Watch Video Solution](#)

30. A cylindrical vessel of height 24 cm and diameter 40 cm is full of water. Find the exact

number of small cylindrical bottles, each of height 10 cm and diameter 8 cm, which can be filled with this water.



[Watch Video Solution](#)

31. Two solid cylinders, one with diameter 60 cm and height 30 cm and the other with radius 30 cm and height 60 cm, are melted and recasted into a third solid cylinder of height 10 cm. Find the diameter of the cylinder formed.



[Watch Video Solution](#)

32. The total surface area of a hollow cylinder, which is open from both the sides, is 3575 cm^2 , area of its base ring is 357.5 cm^2 and its height is 14 cm . Find the thickness of the cylinder.



[Watch Video Solution](#)

33. The given figure shows a solid formed of a solid cube of side 40 cm and a solid cylinder of radius 20 cm and height 50 cm attached to

the cube as shown. Find the volume and the total surface area of the whole solid [Take $\pi = 3.14$]

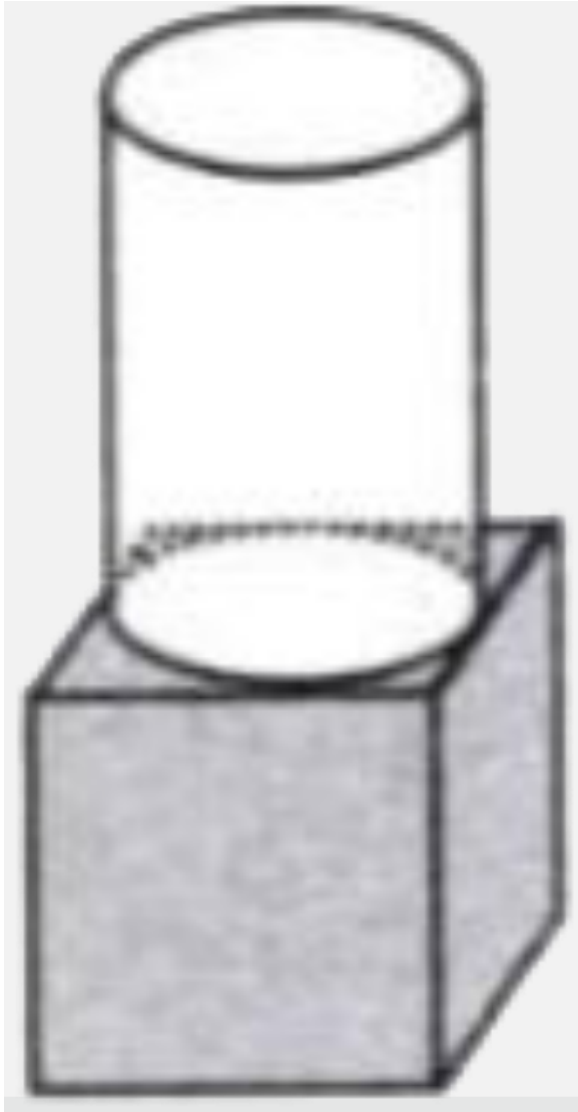



[Watch Video Solution](#)

34. Two right circular solid cylinders have radii in the ratio $3 : 5$ and heights in the ratio $2:3$. Find the ratio between their curved surface areas.



[Watch Video Solution](#)

35. Two right circular solid cylinders have radii in the ratio $3 : 5$ and heights in the ratio $2:3$.

Find the ratio between their volumes.



[Watch Video Solution](#)

36. A closed cylindrical tank, made of thin iron sheet, has diameter = 8.4 m and height 5.4 m.

How much metal sheet, to the nearest m^2 , is

used in making this tank, if $\frac{1}{15}$ of the sheet

actually used was wasted in making the tank ?



[Watch Video Solution](#)

Exercise 20 B

1. Find the volume of a cone whose slant height is 17 cm and radius of base is 8 cm.



[Watch Video Solution](#)

2. The curved surface area of a cone is 12320cm^2 . If the radius of its base is 56 cm, find its height.



[Watch Video Solution](#)

3. The circumference of the base of a 12 m high conical tent is 66 m. Find the volume of the air contained in it.



[Watch Video Solution](#)

4. The radius and the height of a right circular cone are in the ratio 5 : 12 and its volume is 2512 cubic cm. Find the radius and slant height of the cone. (Take $\pi = 3.14$)



[Watch Video Solution](#)

5. Two right circular cones x and y are made. x having three times the radius of y and y having half the volume of x . Calculate the ratio between the heights of x and y .



[Watch Video Solution](#)

6. The diameters of two cones are equal. If their slant heights are in the ratio $5:4$, find the ratio of their curved surface areas.



[Watch Video Solution](#)

7. There are two cones. The curved surface area of one is twice that of the other. The slant height of the latter is twice that of the former. Find the ratio of their radii.



[Watch Video Solution](#)

8. A heap of wheat is in the form of a cone of diameter 16.8 m and height 3.5 m. Find its

volume. How much cloth is required to just cover the heap ?



[Watch Video Solution](#)

9. Find what length of canvas, 1.5 m in width, is required to make a conical tent 48 m diameter and 7 m in height ? Given that 10% of the canvas is used in folds and stitchings. Also, find the cost of the canvas at the rate of Rs.24 per metre.



[Watch Video Solution](#)

10. A solid cone of height 8 cm and base radius 6 cm is melted and recast into identical cones, each of height 2 cm and diameter 1 cm. Find the number of cones formed.



Watch Video Solution

11. The total surface area of a right circular cone of slant height 13 cm is $90\pi\text{cm}^2$. Calculate its radius in cm.



Watch Video Solution

12. The total surface area of a right circular cone of slant height 13 cm is $90\pi cm^2$. Calculate its volume in cm^3 . (Take $\pi = 3.14$).



Watch Video Solution

13. The area of the base of a conical solid is $38.5cm^2$ and its volume is $154cm^3$. Find the curved surface area of the solid.



Watch Video Solution

14. A vessel, in the form of an inverted cone, is filled with water to the brim. Its height is 32 cm and diameter of the base is 25.2 cm. Six equal solid cones are dropped in it, so that they are fully submerged. As a result, one-fourth of water in the original cone overflows. What is the volume of each of the solid cones submerged ?



Watch Video Solution

15. The volume of a conical tent is $1232m^3$ and the area of the base floor is $154m^2$. Calculate the :
radius of the floor,



Watch Video Solution

16. The volume of a conical tent is $1232m^3$ and the area of the base floor is $154m^2$. Calculate the :
height of the tent,



Watch Video Solution

17. The volume of a conical tent is $1232m^3$ and the area of the base floor is $154m^2$. Calculate the :

length of the canvas required to cover this conical tent if its width is 2 m.



[Watch Video Solution](#)

Exercise 20 C

1. The surface area of a sphere is 2464cm^2 ,
find its volume.



[Watch Video Solution](#)

2. The volume of a sphere is 38808cm^3 , find
its diameter and the surface area.



[Watch Video Solution](#)

3. A spherical ball of lead has been melted and made into identical smaller balls with radius equal to half the radius of the original one. How many such balls can be made ?



[Watch Video Solution](#)

4. How many balls each of radius 1 cm can be made by melting a bigger ball whose diameter is 8 cm?



[Watch Video Solution](#)

5. Eight metallic spheres, each of radius 2 mm, are melted and cast into a single sphere. Calculate the radius of the new sphere.



[Watch Video Solution](#)

6. The volume of one sphere is 27 times that of another sphere. Calculate the ratio of their radii,



[Watch Video Solution](#)

7. The volume of one sphere is 27 times that of another sphere. Calculate the ratio of their : surface areas.



[Watch Video Solution](#)

8. If the number of square centimetres on the surface of a sphere is equal to the number of cubic centimetres in its volume, what is the diameter of the sphere?



[Watch Video Solution](#)

9. A solid metal sphere is cut through its centre into 2 equal parts. If the diameter of the sphere is $3\frac{1}{2}$ cm, find the total surface area of each part correct to two decimal places.



[Watch Video Solution](#)

10. The internal and external diameters of a hollow hemispherical vessel are 21 cm and 28

cm respectively. Find :

internal curved surface area,



[Watch Video Solution](#)

11. The internal and external diameters of a hollow hemispherical vessel are 21 cm and 28 cm respectively. Find :

external curved surface area,



[Watch Video Solution](#)

12. The internal and external diameters of a hollow hemispherical vessel are 21 cm and 28 cm respectively. Find :
total surface area,



Watch Video Solution

13. The internal and external diameters of a hollow hemispherical vessel are 21 cm and 28 cm respectively. Find :
volume of material of the vessel.





[Watch Video Solution](#)

14. A solid sphere and a solid hemi-sphere have the same total surface area. Find the ratio between their volumes.



[Watch Video Solution](#)

15. Metallic spheres of radii 6 cm, 8 cm and 10 cm respectively are melted and recasted into a single solid sphere. Taking $\pi = 3.1$, find the surface area of the solid sphere formed.



[Watch Video Solution](#)

16. The surface area of a solid sphere is increased by 21% without changing its shape.

Find the percentage increase in its:

radius



[Watch Video Solution](#)

17. The surface area of a solid sphere is increased by 21% without changing its shape.

Find the percentage increase in its volume .



[Watch Video Solution](#)

Exercise 20 D

1. A solid sphere of radius 15 cm is melted and recast into solid right circular cones of radius 2.5 cm and height 8 cm. Calculate the number of cones recast.



[Watch Video Solution](#)

2. A hollow sphere of internal and external diameters 4 cm and 8 cm respectively is melted into a cone of base diameter 8 cm. Find the height of the cone.



[Watch Video Solution](#)

3. The radii of the internal and external surfaces of a metallic spherical shell are 3 cm and 5 cm respectively. It is melted and recast into a solid right circular cone of height 32 cm. Find the diameter of the base of the cone.



[Watch Video Solution](#)

4. Total volume of three identical cones is the same as that of a bigger cone whose height is 9 cm and diameter 40 cm. Find the radius of the base of each smaller cone, if height of each is 108 cm.



[Watch Video Solution](#)

5. A solid rectangular block of metal 49 cm by 44 cm by 18 cm is melted and formed into a solid sphere. Calculate the radius of the sphere.



[Watch Video Solution](#)

6. A hemispherical bowl of internal radius 9 cm is full of liquid. This liquid is to be filled into conical shaped small containers each of

diameter 3 cm and height 4 cm. How many containers are necessary to empty the bowl?



[Watch Video Solution](#)

7. A hemispherical bowl of diameter 7.2 cm is filled completely with chocolate sauce. This sauce is poured into an inverted cone of radius 4.8 cm. Find the height of the cone if it is completely filled



[Watch Video Solution](#)

8. A solid cone of radius 5 cm and height 8 cm is melted and made into small spheres of radius 0.5 cm. Find the number of spheres formed.



[Watch Video Solution](#)

9. The total area of a solid metallic sphere is 1256cm^2 . It is melted and recast into solid right circular cones of radius 2.5 cm and height 8 cm. Calculate :

the radius of the solid sphere, and the no. of cones cast ($\pi=3.14$).



[Watch Video Solution](#)

10. The total area of a solid metallic sphere is 1256cm^2 . It is melted and recast into solid right circular cones of radius 2.5 cm and height 8 cm. Calculate :
the number of cones recast.



[Watch Video Solution](#)

11. A solid metallic cone, with radius 6 cm and height 10 cm, is made of some heavy metal A. In order to reduce its weight, a conical hole is made in the cone as shown and it is completely filled with a lighter metal B. The conical hole has a diameter of 6 cm and depth 4 cm. Calculate the ratio of the volume of metal A to the volume of the metal B in the

solid.



[Watch Video Solution](#)

12. A hollow sphere of internal and external radii 6 cm and 8 cm respectively is melted and

recast into small cones of base radius 2 cm and height 8 cm. Find the number of cones.



[Watch Video Solution](#)

13. The surface area of a solid metallic sphere is 2464cm^2 . It is melted and recast into solid right circular cones of radius 3.5 cm and height 7 cm. Calculate :
the radius of the sphere and the number of cones recast.



[Watch Video Solution](#)

14. The surface area of a solid metallic sphere is 2464cm^2 . It is melted and recast into solid right circular cones of radius 3.5 cm and height 7 cm. Calculate :

the number of cones recast. (Take $\pi = \frac{22}{7}$)



Watch Video Solution

Exercise 20 E

1. A cone of height 15 cm and diameter 7 cm is mounted on a hemisphere of same diameter. Determine the volume of the solid thus formed.



[Watch Video Solution](#)

2. A buoy is made in the form of hemisphere surmounted by a right cone whose circular base coincides with the plane surface of hemisphere. The radius of the base of the

cone is 3.5 metres and its volume is two-third of the hemisphere. Calculate the height of the cone and the surface area of the buoy, correct to two places of decimal.



[Watch Video Solution](#)

3. From a rectangular solid of metal 42 cm by 30 cm by 20 cm, a conical cavity of diameter 14 cm and depth 24 cm is drilled out. Find :
the surface area of remaining solid,



[Watch Video Solution](#)

4. From a rectangular solid of metal 42 cm by 30 cm by 20 cm, a conical cavity of diameter 14 cm and depth 24 cm is drilled out. Find :
the volume of remaining solid,



[Watch Video Solution](#)

5. From a rectangular solid of metal 42 cm by 30 cm by 20 cm, a conical cavity of diameter 14 cm and depth 24 cm is drilled out. Find :

the weight of the material drilled out if it weighs 7 gm per cm^3 .



[Watch Video Solution](#)

6. A cubical block of side 7 cm is surmounted by a hemisphere. What is the greatest diameter of the hemisphere can have? Find the total surface area of the solid.



[Watch Video Solution](#)

7. A vessel is in the form of an inverted cone. Its height is 8 cm and the radius of its top, which is open, is 5 cm. It is filled with water up to the brim. When lead shots, each of which is a sphere of radius 0.5 cm are dropped into the vessel, on



[Watch Video Solution](#)

8. A hemi-spherical bowl has negligible thickness and the length of its circumference

is 198 cm. Find the capacity of the bowl.



[Watch Video Solution](#)

9. The maximum volume of a cone that can be carved out of a solid hemisphere of radius r is

$3\pi r^2$ (b) $\frac{\pi r^3}{3}$ (c) $\frac{\pi r^2}{3}$ (d) $3\pi r^3$



[Watch Video Solution](#)

10. The radii of the bases of two right circular solid cones of same height are r_1 and r_2

respectively. The cones are melted and recast into a solid sphere of radius R . Show that the height of each cone is given by

$$h = \frac{4R^3}{r_1^2 + r_2^2}$$



[Watch Video Solution](#)

11. A solid metallic hemisphere of diameter 28 cm is melted and recast into a number of identical solid cones, each of diameter 14 cm and height 8 cm. Find the number of cones so formed.



[Watch Video Solution](#)

12. A cone and a hemisphere have the same base and the same height. Find the ratio between their volumes.



[Watch Video Solution](#)

Exercise 20 F

1. From a right circular cylinder with height 10cm and radius of base 6cm, a right circular cone of the same height and base is removed. Find the volume of the remaining solid.



[Watch Video Solution](#)

2. From a solid cylinder whose height is 16 cm and radius is 12 cm, a conical cavity of height 8 cm and of base radius 6 cm is hollowed out.

Find the volume and total surface area of the remaining solid.



[Watch Video Solution](#)

3. A circus tent is cylindrical to a height of 4 m and conical above it. If its diameter is 105 m and its slant height is 80 m, calculate the total area of canvas required. Also, find the total cost of canvas used at Rs 15 if the width is 1.5 m.



[Watch Video Solution](#)

4. A circus tent is cylindrical to a height of 8 m surmounted by a conical part. If total height of the tent is 13 m and the diameter of its base is 24 m, calculate :

total surface area of the tent,



[Watch Video Solution](#)

5. A circus tent is cylindrical to a height of 8 m surmounted by a conical part. If total height of the tent is 13 m and the diameter of its base is

24 m, calculate :

area of canvas, required to make this tent
allowing 10% of the canvas used for folds and
stitching



[Watch Video Solution](#)

6. A cylindrical boiler, 2 m high, is 3.5 m in diameter. It has a hemispherical lid. Find the volume of its interior, including the part covered by the lid.



[Watch Video Solution](#)

7. A vessel is a hollow cylinder fitted with a hemispherical bottom of the same base. The depth of the cylinder is $\frac{14}{3}$ m and the diameter of hemisphere is 3.5 m. Calculate the volume and the internal surface area of the solid.



[Watch Video Solution](#)

8. A wooden toy is in the shape of a cone mounted on a cylinder as shown alongside.

If the height of the cone is 24 cm, the total height of the toy is 60 cm and the radius of the base of the cone = twice the radius of the base of the cylinder = 10 cm, find the total

surface area of the toy. Take $\pi = 3.14$]



Watch Video Solution

9. A cylindrical container with diameter of base 42 cm contains sufficient water to submerge a rectangular solid of iron with dimensions $22\text{cm} \times 14\text{cm} \times 10.5\text{cm}$. Find the rise in level of the water when the solid is submerged.



Watch Video Solution

10. Spherical marbles of diameter 1-4 cm are dropped into a beaker containing some water and are fully submerged. The diameter of the

beaker is 7 cm. Find how many marbles have been dropped in it if the water rises by 5.6 cm ?



[Watch Video Solution](#)

11. The cross-section of a railway tunnel is a rectangle 6 m broad and 8 m high surmounted by a semi-circle . The tunnel is 35 m long. Find the cost of plastering the internal surface of the tunnel (excluding the floor) at the rate of Rs 2.25 per m^2



[Watch Video Solution](#)

12. The horizontal cross-section of a water tank is in the shape of a rectangle with semi-circle at one end, as shown in the following figure. The water is 2.4 metres deep in the tank. Calculate the volume of water in the tank in gallons.



[Watch Video Solution](#)

13. The given figure shows the cross-section of a water channel consisting of a rectangle and a semi-circle. Assuming that the channel is always full, find the

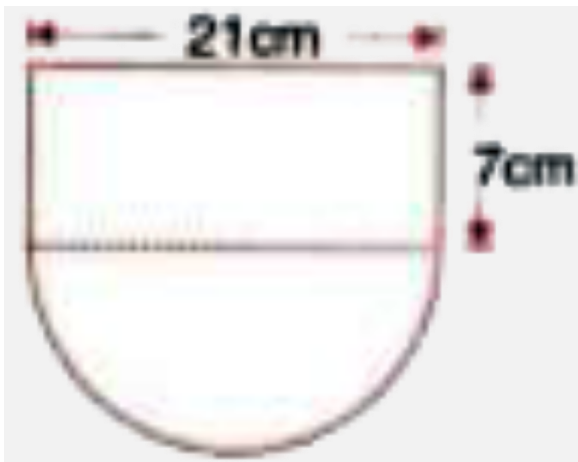

volume of water discharged through it in one minute if water is flowing at the rate of 20 cm per second. Give your answer in cubic metres correct to one place of decimal.



Watch Video Solution

14. An open cylindrical vessel of internal diameter 7 cm and height 8 cm stands on a horizontal table. Inside this is placed a solid metallic right circular cone, the diameter of whose base is $3\frac{1}{2}$ cm and height 8 cm. Find the volume of water required to fill the vessel.

If this cone is replaced by another cone, whose height is $1\frac{3}{4}$ cm and the radius of whose base is 2 cm, find the drop in the water level.



Watch Video Solution

15. A cylindrical can, whose base is horizontal and of radius 3-5 cm, contains sufficient water so that when a sphere is placed in the can, the water just covers the sphere. Given that the sphere just fits into the can, calculate :
the total surface area of the can in contact with water when the sphere is in it,



Watch Video Solution

16. A cylindrical can, whose base is horizontal and of radius 3-5 cm, contains sufficient water so that when a sphere is placed in the can, the water just covers the sphere. Given that the sphere just fits into the can, calculate :
the depth of water in the can before the sphere was put into the can.



Watch Video Solution

17. A hollow cylinder has solid hemisphere inward at one end and on the other end it is closed with a flat circular plate. The height of water is 10 cm when flat circular surface is downward. Find the level of water, when it is inverted upside down, common diameter is 7 cm and height of the cylinder is 20 cm.



[Watch Video Solution](#)

Exercise 20 G

1. What is the least number of solid metallic spheres, each of 6 cm diameter, that should be melted and recast to form a solid metal cone whose height is 45 cm and diameter 12 cm ?



[Watch Video Solution](#)

2. A largest sphere is to be carved out of a right circular cylinder of radius 7 cm and height 14 cm. Find the volume of the sphere. (Answer correct to the nearest integer).



[Watch Video Solution](#)

3. A right circular cylinder having diameter 12 cm and height 15 cm is full of ice-cream. The ice-cream is to be filled in cones of height 12 cm and diameter 6 cm having a hemispherical shape on the top. Find the number of such cones which can be filled with ice-cream.



[Watch Video Solution](#)

4. A solid is in the form of a cone standing on a hemi-sphere with both their radii being

equal to 8 cm and the height of cone is equal to its radius. Find the volume of the solid in terms of π .



[Watch Video Solution](#)

5. The diameter of a sphere is 6 cm. It is melted and drawn into a wire of diameter 0.2 cm. Find the length of the wire.



[Watch Video Solution](#)

6. What is the ratio of the volume of a cube to that of a sphere which will fit inside it?



[Watch Video Solution](#)

7. A solid iron pole having cylindrical portion 110cm high and of base diameter 12cm is surmounted by a cone 9cm high Find the mass of the pole, given that the mass of 1cm^3 of iron is 8gm .



[Watch Video Solution](#)

8. In the following diagram a rectangular platform with a semi-circular end on one side is 22 metres long from one end to the other end. If the length of the half circumference is 11 metres, find the cost of constructing the platform, 1.5 metres high at the rate of Rs 4 per cubic metres.



[Watch Video Solution](#)

9. The cross-section of a tunnel is a square of side 7 m surmounted by a semicircle. The tunnel is 80 m long ,Calculate : its volume



[Watch Video Solution](#)

10. The cross-section of a tunnel is a square of side 7 m surmounted by a semicircle. The tunnel is 80 m long Calculate : the surface area of the tunnel (excluding the floor) .



[Watch Video Solution](#)

11. The cross-section of a tunnel is a square of side 7 m surmounted by a semicircle. Calculate: its floor area. The tunnel is 80 m long.



Watch Video Solution

12. A cylindrical water tank of diameter 2.8 m and height 4.2 m is being fed by a pipe of diameter 7 cm through which water flows at

the rate of 4 m s^{-1} . Calculate, in minutes, the time it takes to fill the tank



[Watch Video Solution](#)

13. Water flows, at 9 km per hour, through a cylindrical pipe of cross-sectional area 25 cm²? If this water is collected into a rectangular cistern of dimensions 7.5 m by 5 m by 4 m, calculate the rise in level in the cistern in 1 hour 15 minutes.



[Watch Video Solution](#)

14. The given figure shows the cross-section of a cone, a cylinder and a hemisphere all with the same diameter 10 cm, and the other dimensions are as shown. Calculate the total surface area.



Watch Video Solution

15. A solid consisting of a right circular cone, standing on a hemisphere, is placed upright, in a right circular cylinder, full of water, and

touches the bottom. Find the volume of water left in the cylinder, having given that the radius of the cylinder is 3 cm and its height is 6 cm, the radius of the hemisphere is 2 cm and the height of the cone is 4 cm. Give your answer correct to the nearest centimetre

(Take $\pi = 3\frac{1}{7}$)



[Watch Video Solution](#)

16. A metal container in the form of a cylinder is surmounted by a hemisphere of the same

radius. The internal height of the cylinder is 7 m and the internal radius is 3.5 m. Calculate : the total area of the internal surface, excluding the base,



[Watch Video Solution](#)

17. A metal container in the form of a cylinder is surmounted by a hemisphere of the same radius. The internal height of the cylinder is 7 m and the internal radius is 3.5 m. Calculate : the internal volume of the container in m^3 .



[Watch Video Solution](#)

18. An exhibition tent is in the form of a cylinder surmounted by a cone. The height of the tent above the ground is 85 m and height of the cylindrical part is 50 m. If the diameter of the base is 168 m, find the quantity of canvas required to make the tent. Allow 20% extra for fold and for stitching. Give your answer to the nearest m^2 .



[Watch Video Solution](#)

19. A test tube consists of a hemisphere and a cylinder of the same radius. The volume of the water required to fill the whole tube is $\frac{5159}{6} \text{ cm}^3$, and $\frac{4235}{6} \text{ cm}^3$ of water is required to fill the tube to a level which is 4 cm below the top of the tube. Find the radius of the tube and the length of its cylindrical part.



Watch Video Solution

20. A solid is in the form of a right circular cone mounted on a hemisphere. The diameter of the base of the cone, which exactly coincides with hemisphere, is 7 cm and its height is 8 cm. The solid is placed in a cylindrical vessel of internal radius 7 cm and height 10 cm. How much water, in cm^3 , will be required to fill the vessel completely?



[Watch Video Solution](#)

21. Two solid spheres of radii 2 cm and 4 cm are melted and recast into a cone of height 8 cm. Find the radius of the cone so formed.



Watch Video Solution

22. A certain number of metallic cones, each of radius 2 cm and height 3 cm, are melted and recast into a solid sphere of radius 6 cm. Find the number of cones used.



Watch Video Solution

23. A conical tent has to accommodate 77 persons. Each person must have 16 m^3 of air to breathe. Given the radius of the tent as 7 m, find the height of the tent and also its curved surface area.



Watch Video Solution