



PHYSICS

BOOKS - SELINA PHYSICS (ENGLISH)

SAMPLE PAPER 2018

Section I

1. State and define the S.I. unit of power.



Watch Video Solution

2. How is the unit horse power related to the S.I. unit of power ?



[Watch Video Solution](#)

3. State the energy changes in the following cases while in use :

An electric iron



[Watch Video Solution](#)

4. State the energy changes in the following cases while in use :

A ceiling fan



[Watch Video Solution](#)

5. The diagram below shows a lever in use :

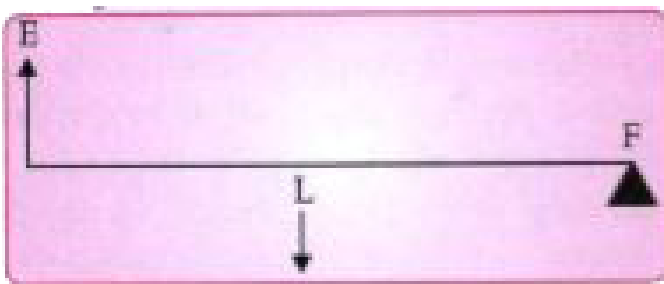

To which class of levers does it belong ?



[Watch Video Solution](#)

6. The diagram below shows a lever in use :

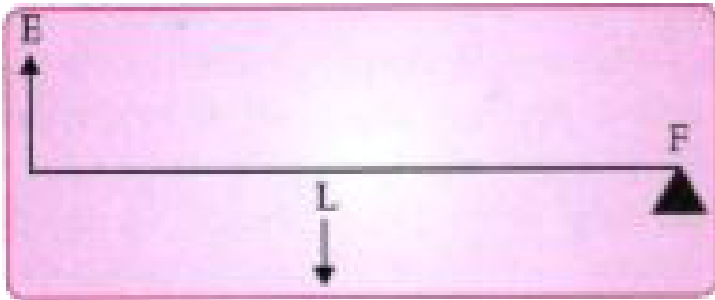

Without changing the dimensions of the lever, if the load is shifted towards the fulcrum what happens to the mechanical advantage of the lever ?



[Watch Video Solution](#)

7. Why is the ratio of the velocities of light of wavelengths 4000 \AA and 8000 \AA in vacuum 1 : 1?



[Watch Video Solution](#)

8. (a) Write the approximate wavelength for (i) blue, and (ii) red light

(b) The wavelength of violet and red light are 4000 \AA and 8000 \AA respectively. Which of the two has higher frequency?



[Watch Video Solution](#)

9. Why is the motion of a body moving with a constant speed around a circular path said to be accelerated ?



[Watch Video Solution](#)

10. Name the unit of physical quantity obtained by the formula $\frac{2K}{v^2}$.

where K : kinetic energy, v : linear velocity.



[Watch Video Solution](#)

11. The power of a lens is -5 D .

Find its focal length.



Watch Video Solution

12. The power of a lens is -5 D .

Name the type of lens.



Watch Video Solution

13. State the position of the object in front of a converging lens if :

It produces a real and same size image of the object.



Watch Video Solution

14. State the position of the object in front of a converging lens if :

It is used as a magnifying lens.



Watch Video Solution

15. (i) What is the relation between critical angle and refractive index of a material ?

(ii) Does critical angle depend on the color of light ? Explain.



Watch Video Solution

16. Which colour of light has a higher critical angle? Red light or Green light.



Watch Video Solution

17. (i) Define scattering.

(ii) The smoke from a fire looks white.

Which of the following statements is true ?

(1) Molecules of the smoke are bigger than the wavelength of light.

(2) Molecules of the smoke are smaller than the wavelength of light.



Watch Video Solution

18. The following diagram shows a 60° , 30° , 90° glass prism of critical angle 42° .

Copy the diagram and complete the path of incident ray AB emerging out of the prism marking the angle of incidence on each surface.

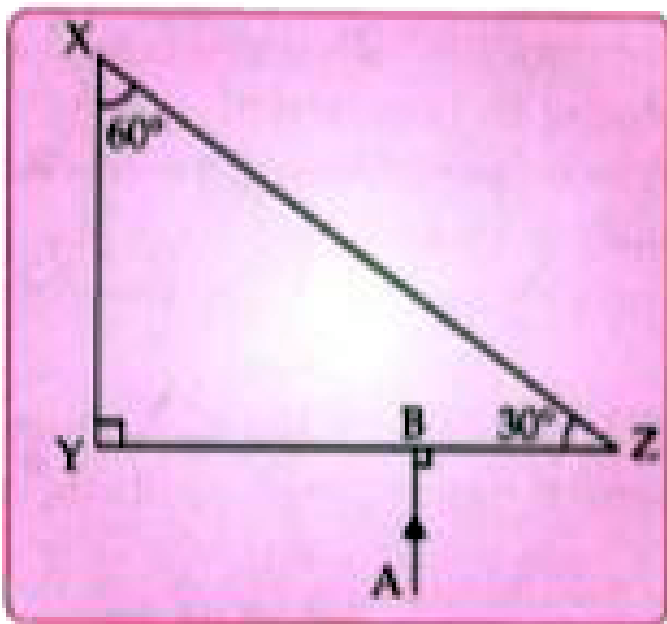



Watch Video Solution

19. Displacement distance graph of two sound waves A and B, travelling in a medium, are as shown in the diagram below:

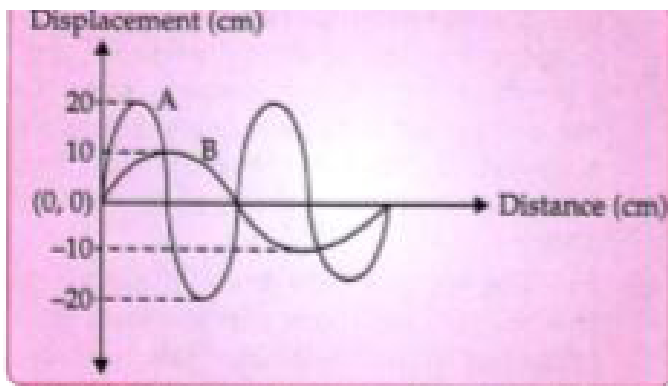

Study the two sound waves and compare their

:

Amplitudes



Watch Video Solution

20. Displacement distance graph of two sound waves A and B, travelling in a medium, are as shown in the diagram below:

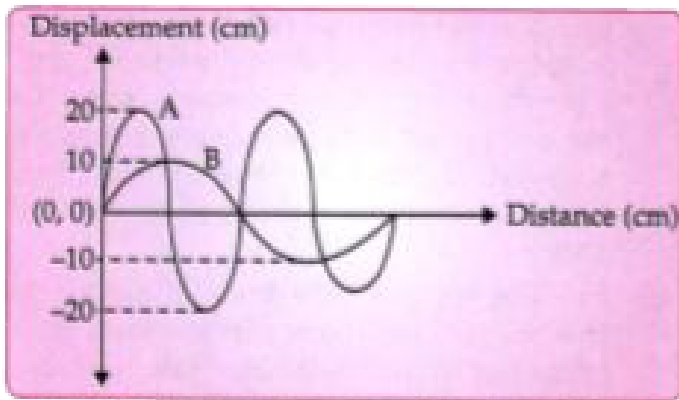

Study the two sound waves and compare their

:

Wavelengths



[Watch Video Solution](#)

21. You have three resistors of values 2Ω , 3Ω and 5Ω . How will you join them so that the total resistance is more than 7Ω ?

Draw a diagram for the arrangement.



[Watch Video Solution](#)

22. You have three resistors of values 2Ω , 3Ω and 5Ω . How will you join them so

that the total resistance is more than 7Ω ?

Calculate the equivalent resistance.



[Watch Video Solution](#)

23. What do you understand by the term nuclear fusion ?



[Watch Video Solution](#)

24. Nuclear power plants use the nuclear fission reaction to produce electricity. What is

the advantage of producing electricity by fusion reaction ?



[Watch Video Solution](#)

25. What do you understand by free vibrations of a body?



[Watch Video Solution](#)

26. Why does the amplitude of a vibrating body continuously decrease during damped

vibrations ?



[Watch Video Solution](#)

27. How is the e.m.f. across primary and secondary coils of a transformer related with the number of turns of coil in them?



[Watch Video Solution](#)

28. On which type of current do transformers work ?



[Watch Video Solution](#)

29. How can a temperature in degree Celsius be converted into S.I. unit of temperature ?



[Watch Video Solution](#)

30. A liquid X has the maximum specific heat capacity and is used as a coolant in car radiators. Name the liquid X.



[Watch Video Solution](#)

31. A solid metal weighing 150 g melts at its melting point of $800^{\circ}C$ by providing heat at the rate of 100 W. The time taken for it to completely melt at the same temperature is 4 min. What is the specific latent heat of fusion of the metal ?



Watch Video Solution

32. Identify the following wires used in a household circuit :

The wire is also called as the phase wire.



[Watch Video Solution](#)

33. Identify the following wires used in a household circuit :

The wire is connected to the top terminal of a three pin socket.



[Watch Video Solution](#)

34. Two atoms are said to be isobars if



[Watch Video Solution](#)

35. Give one example of isobars.



[Watch Video Solution](#)

36. State two advantages of an electromagnet over a permanent magnet.



[Watch Video Solution](#)

Section II

1. Derive a relationship between S.I. and C.G.S. unit of work.



[Watch Video Solution](#)

2. A Force F acts on a body and displaces it by a distance S in direction at an angle θ with the direction of force ,(a) Write the expression for the work done by the force,(b)What should be

the angle between the force and displacement
so that the work done is (i) zero ,(ii) Maximum ?



[Watch Video Solution](#)

3. A half metre rod is pivoted at the centre with two weights of 20 gf and 12 gf suspended at a perpendicular distance of 6 cm and 10 cm from the pivot respectively as shown below.

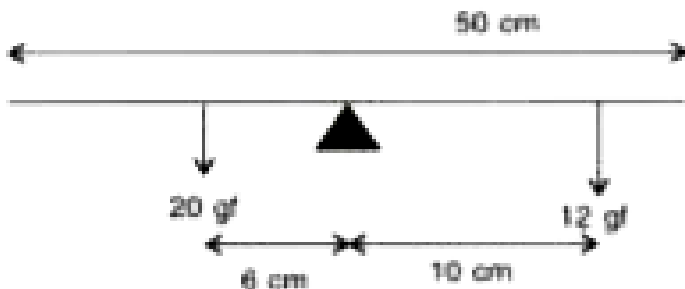

Which of the two forces acting on the rigid rod causes clockwise moment?



[Watch Video Solution](#)

4. A half metre rod is pivoted at the centre with two weights of 20 gf and 12 gf suspended at a perpendicular distance of 6 cm and 10 cm from the pivot respectively as shown below:

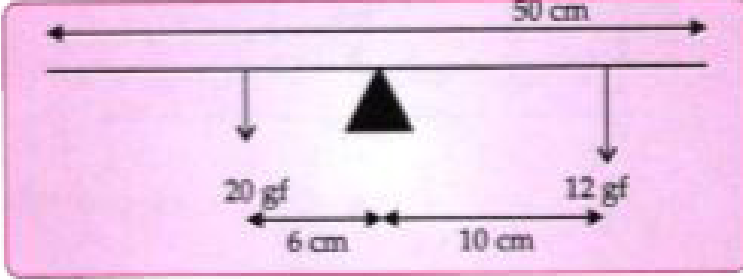

Is the rod in equilibrium ?



[Watch Video Solution](#)

5. A half metre rod is pivoted at the centre with two weights of 20 gf and 12 gf suspended at a perpendicular distance of 6 cm and 10 cm from the pivot respectively as shown below:

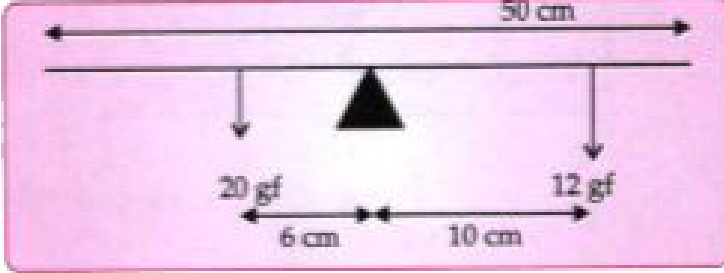

The direction of 20 kgf force is reversed. What is the magnitude of the resultant moment of the forces on the rod ?

 [Watch Video Solution](#)

6. Draw a diagram to show a block and tackle pulley system having a velocity ratio of 3 marking the direction of load (L), effort (E) and

tension (T).

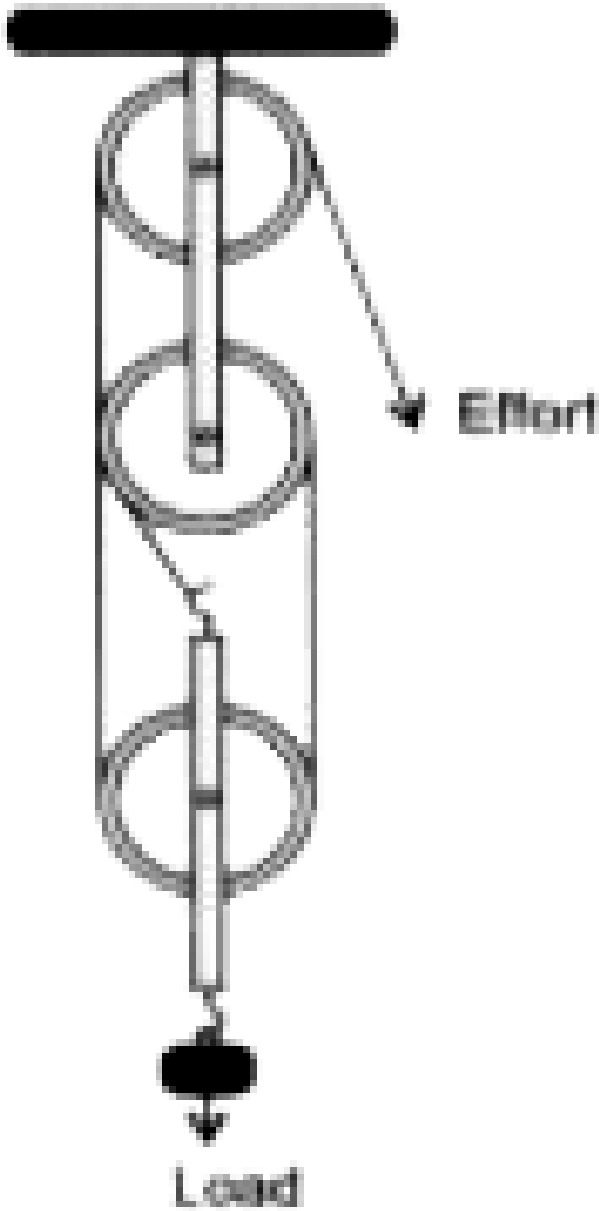

Watch Video Solution

7. A pulley system has a velocity ratio 3. draw a diagram showing the point of application and direction of load (L), effort (E) and tension (T). It lifts a load of 150 N by an effort of 60 N. calculate its mechanical advantage. Is the pulley system ideal ? Give reason.



[Watch Video Solution](#)

8.

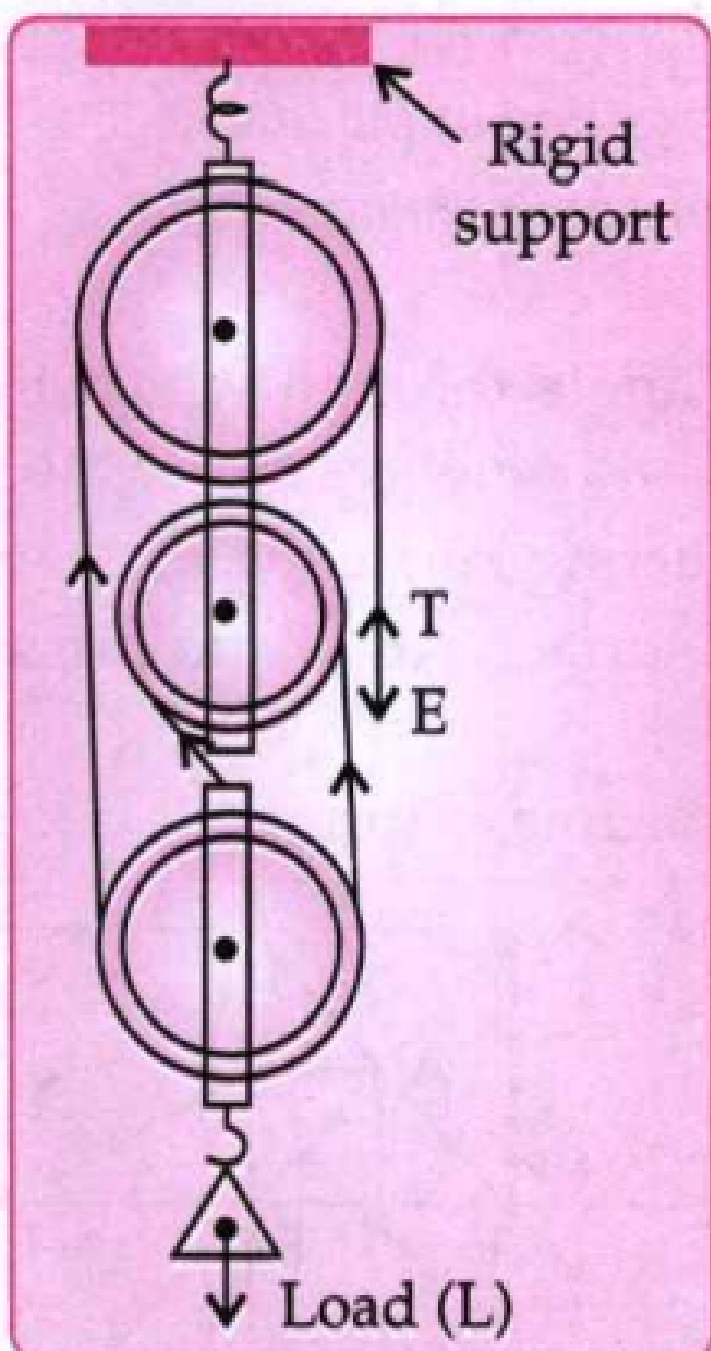

Is the above pulley system an ideal machine or not ?

 [Watch Video Solution](#)

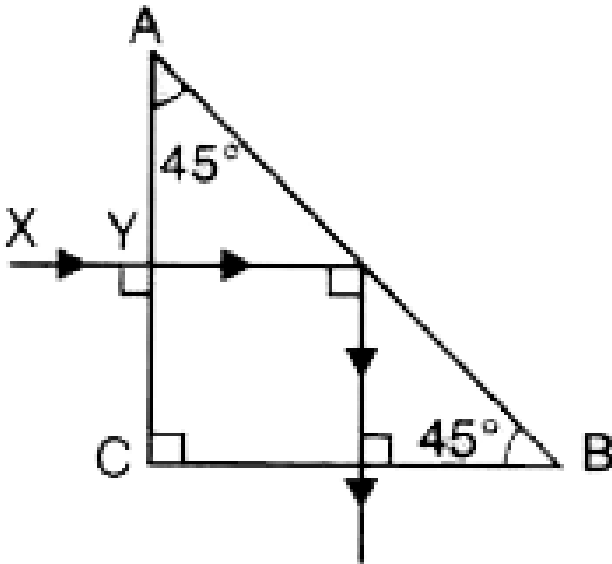

9.

A ray of light XY passes through a right angled

isosceles prism as shown alongside Figure.

(a) What is the angle through which the incident ray deviates and emerges out of the prism?

9b) Name the instrument where this action of prism is put into use.

(c) Which prism surface will behave as a mirror ?



Watch Video Solution

10. A ray of light XY passes through a right angled isosceles prism as shown alongside.

Name the instrument where this action of prism is put into use.

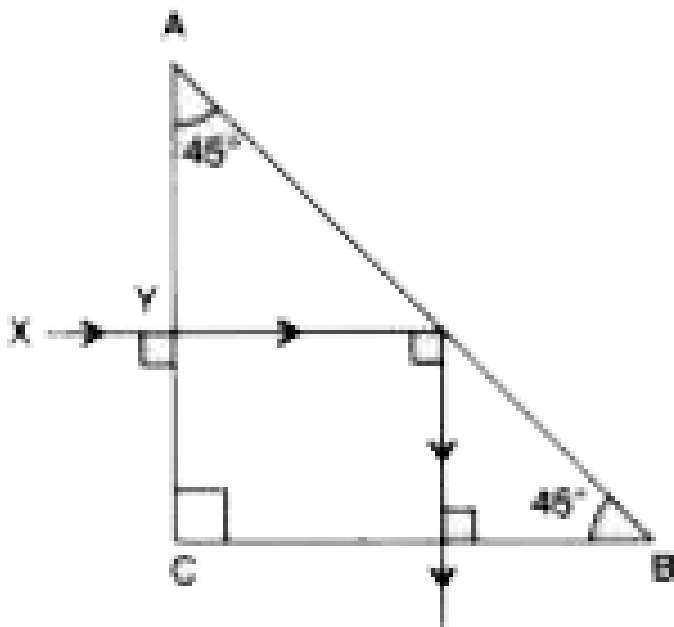

[Watch Video Solution](#)

11. A ray of light XY passes through a right angled isosceles prism as shown below:

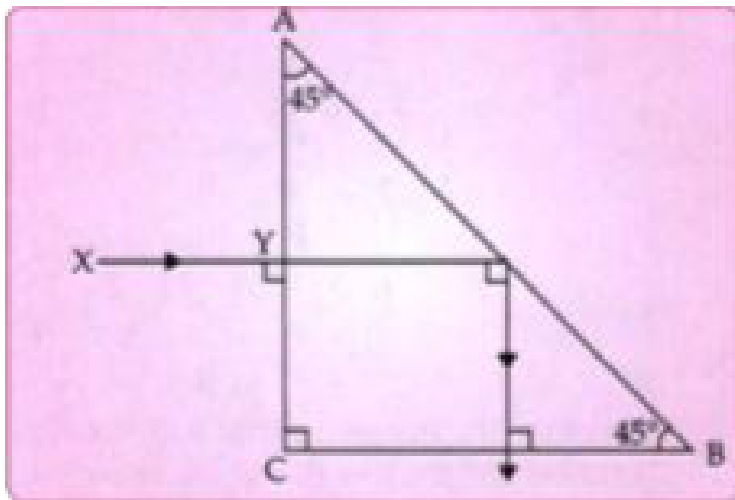

Which prism surface will behave as a mirror ?



[Watch Video Solution](#)

12. An object AB is placed between O and F_1 on the principal axis of a converging lens as shown in the diagram.

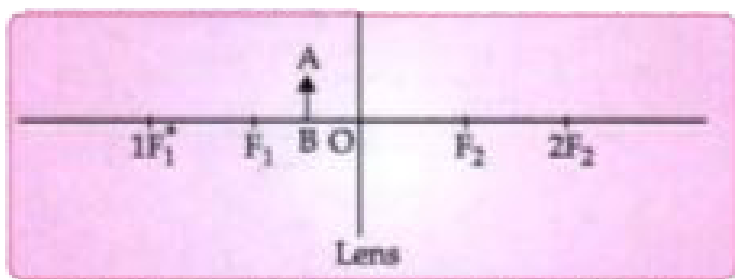

Mark is an error by the Council. We suggest you to use ' $2F_1$ ' instead of ' $1F_1$ '.

Copy the diagram and by using three standard rays starting from point A, obtain an image of the object AB.

 [Watch Video Solution](#)

13. An object is placed at a distance of 12 cm from a convex lens of focal length 8 cm. Find :
the position of the image



Watch Video Solution

14. An object is placed at a distance of 12 cm from a convex lens of focal length 8 cm. Find :
nature of the image



Watch Video Solution

15. Draw a diagram of a right angled isosceles prism which is used to make an inverted image erect.



Watch Video Solution

16. The diagram below shows a wire stretched over a sonometer. Stems of two vibrating tuning forks A and B are touched in turn to the wooden box of the sonometer. It is observed that the paper rider (a small piece of

paper folded at the centre) present on the wire flies off when the stem of vibrating tuning fork B is touched to the wooden box but the paper just vibrates when the stem of vibrating tuning fork A is touched to the wooden box.

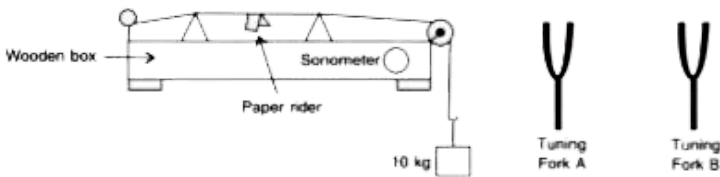

Name the phenomenon when the paper rider just vibrates.



[Watch Video Solution](#)

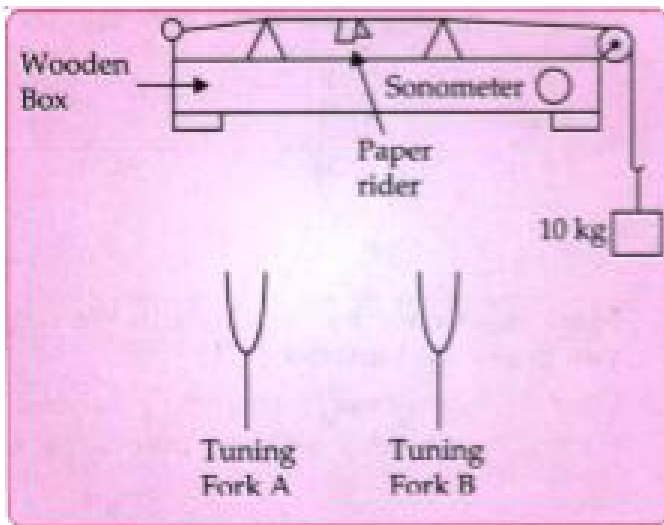

17.

The diagram above shows a wire stretched over a sonometer. Stems of two vibrating tuning forks A and B are touched to the wooden box of the sonometer. It is observed that the paper rider (a small piece of paper folded at the centre) present on the wire flies off when the stem of vibrating tuning fork B is

touched to the wooden box but the paper just vibrates when the stem of vibrating tuning fork A is touched to the wooden box.

Name the phenomenon when the paper rider flies off.



[Watch Video Solution](#)

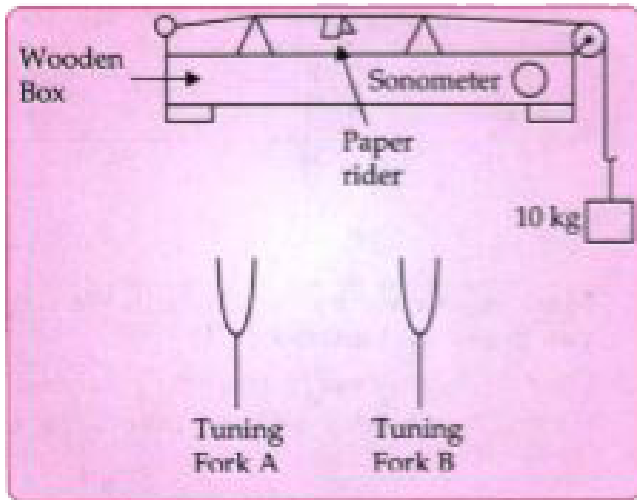

18.

The diagram above shows a wire stretched over a sonometer. Stems of two vibrating tuning forks A and B are touched to the wooden box of the sonometer. It is observed that the paper rider (a small piece of paper folded at the centre) present on the wire flies

off when the stem of vibrating tuning fork B is touched to the wooden box but the paper just vibrates when the stem of vibrating tuning fork A is touched to the wooden box.

Why does the paper rider fly off when the stem of tuning fork B is touched to the box ?



[Watch Video Solution](#)

19. A person is standing at the sea shore. An observer on the ship which is anchored in between a vertical cliff and the person on the

shore fires a gun. the person on the shore hears two sounds, 2 seconds and 3 seconds after seeing the smoke of the fired gun. If the speed of sound in the air is 320 m s^{-1} , then calculate :

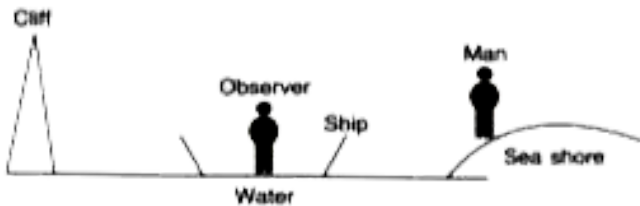

the distance between the observer on the ship and the person on the shore.



[Watch Video Solution](#)

20. A person is standing at the sea shore. An observer on the ship which is anchored in between a vertical cliff and the person on the shore fires a gun. the person on the shore hears two sounds, 2 seconds and 3 seconds after seeing the smoke of the fired gun. If the speed of sound in the air is 320 ms^{-1} , then calculate :

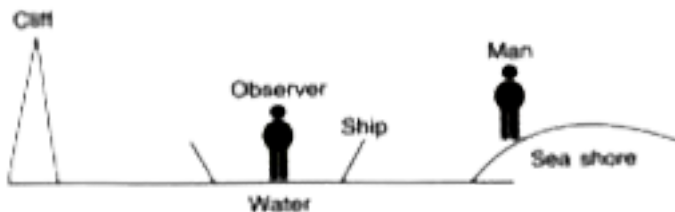

the distance between the cliff and the observer on the ship.



[Watch Video Solution](#)

21. A fuse is rated 8 A. Can it be used with an electrical appliance rated 5 kW, 200 V ? Give a reason.



[Watch Video Solution](#)

22. Name two safety devices which are connected to the live wire of a household electric circuit.

 [Watch Video Solution](#)

23. Find the equivalent resistance between A and B.

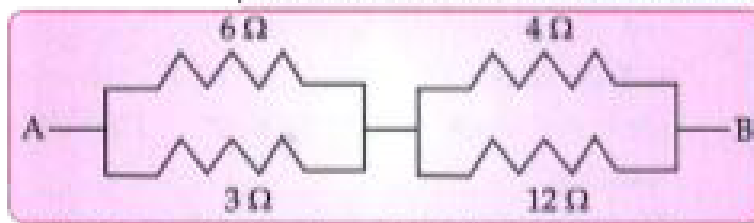

 [Watch Video Solution](#)

24. State whether the resistivity of a wire changes with the change in the thickness of the wire.



Watch Video Solution

25. An electric iron is rated 220 V, 2 kW.

If the iron is used for 2 h daily find the cost of running it for one week if it costs Rs. 4.25 per kWh.



 [Watch Video Solution](#)

26. An electric iron is rated at 220 V, 2 kW.

Why is the fuse absolutely necessary in a power circuit?



[Watch Video Solution](#)

27. Heat supplied to a solid changes it into liquid. What is this change in phase called ?



[Watch Video Solution](#)

28. During the phase change does the average kinetic energy of the molecules of the substance increase ?



Watch Video Solution

29. What is the energy absorbed during the phase change called ?



Watch Video Solution

30. State two differences between "Heat Capacity" and "Specific Heat Capacity"



Watch Video Solution

31. What is the relationship between heat capacity and specific heat capacity of a substance ?



Watch Video Solution

32. The temperature of 170 g of water at 50°C is lowered to 5°C by adding certain amount of ice to it. Find the mass of ice added. Given : Specific heat capacity of water = $4200\text{ J kg}^{-1}\text{ }^{\circ}\text{C}^{-1}$ and specific latent heat of ice = 336000 J kg^{-1} .



Watch Video Solution

33. The diagram shows a coil wound around a U shape soft iron bar AB.

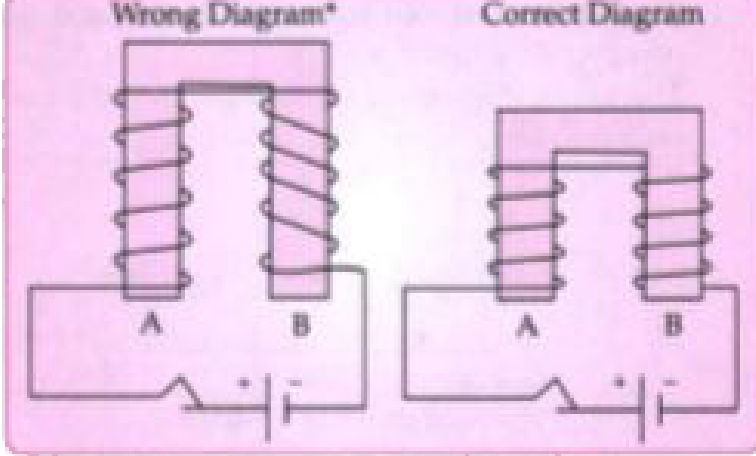

What is the polarity induced at the ends A and B when the switch is pressed ?

[Watch Video Solution](#)

34. The diagram shows a coil wound around a U shape soft iron bar AB.

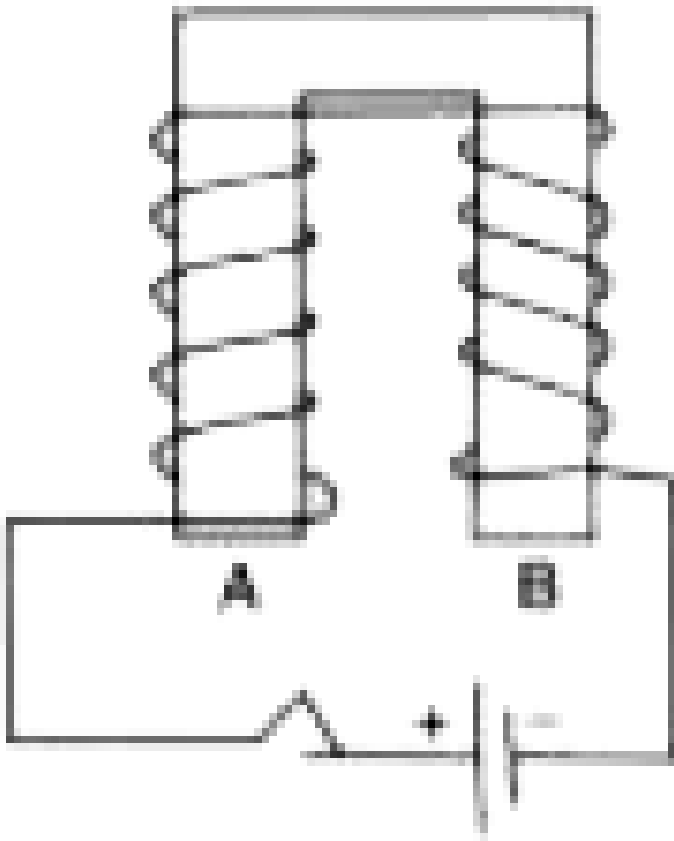

Suggest one way to strengthen the magnetic field in the electromagnet.



Watch Video Solution

35. The diagram shows a coil wound around a U shape soft iron bar AB.

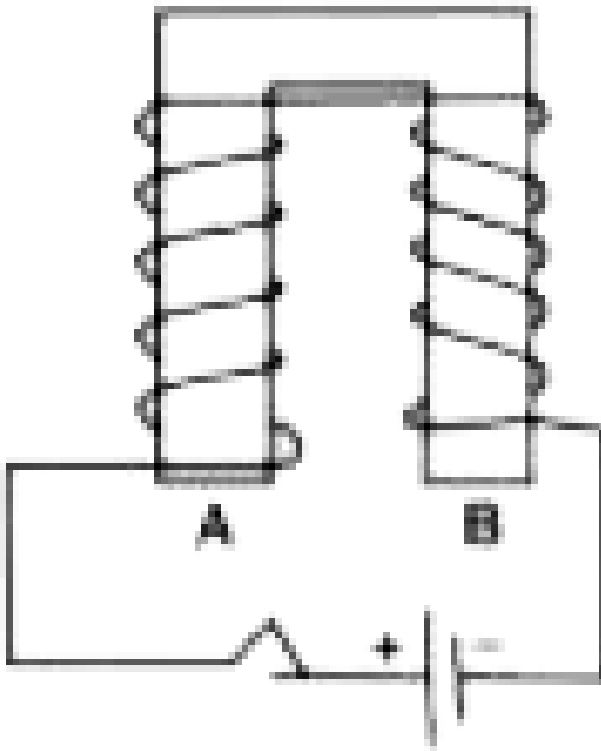

What will be the polarities at A and B if the direction of current is reversed in the circuit ?



Watch Video Solution

36. The ore of Uranium found in nature contains ${}_{92}^{238}\text{U}$ and ${}_{92}^{235}\text{U}$. Although both the isotopes are fissionable, it is found out experimentally that one of the two isotopes is more easily fissionable.

Name the isotope of Uranium which is easily fissionable



Watch Video Solution

37. The ore of uranium found in nature contains ${}_{92}\text{U}^{238}$ and ${}_{92}\text{U}^{235}$. Although both the isotopes are fissionable, it is found out experimentally that one of the two isotopes is more easily fissionable.

Give a reason for your answer.



Watch Video Solution

38. The ore of uranium found in nature contains ${}_{92}\text{U}^{238}$ and ${}_{92}\text{U}^{235}$. Although both the isotopes are fissionable, it is found out

experimentally that one of the two isotopes is more easily fissionable.

Write a nuclear reaction when Uranium 238 emits an alpha particle to form a Thorium (Th) nucleus.



[Watch Video Solution](#)

39. Radiations given out from a source when subjected to an electric field in a direction perpendicular to their path are shown below in the diagram. The arrows show the path of

the radiation A, B and C. Answer the following question in terms of A, B and C.

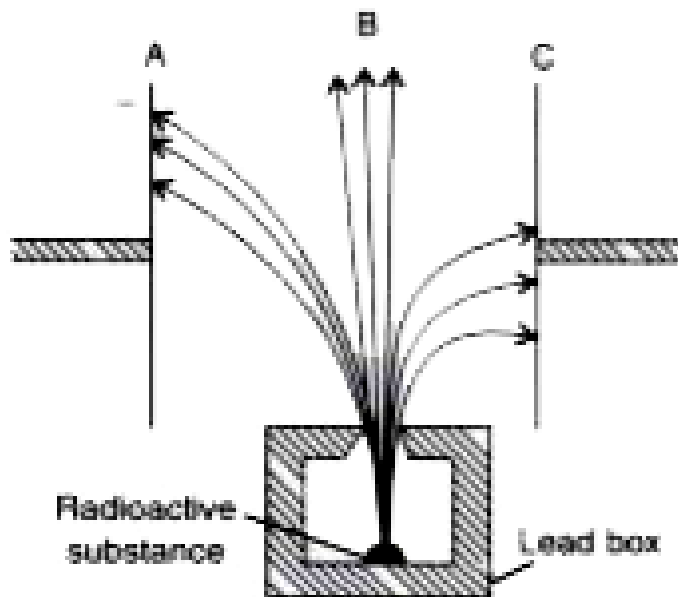

Name the radiation B which is unaffected by the electrostatic field.



[Watch Video Solution](#)

40. Radiations given out from a source when subjected to an electric field in a direction perpendicular to their path are shown below in the diagram. The arrows show the path of the radiation A, B and C. Answer the following question in terms of A, B and C.

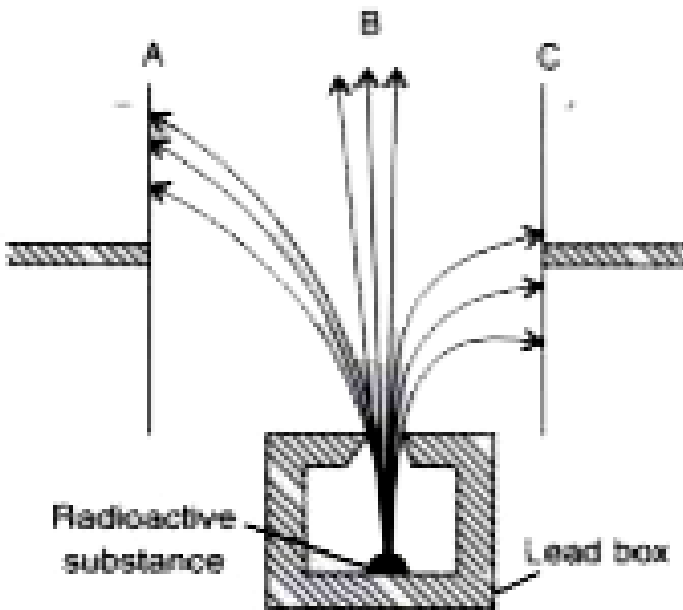

Why does the radiation C deflect more than A?



[Watch Video Solution](#)

41. Radiations given out from a source when subjected to an electric field in a direction

perpendicular to their path are shown below in the diagram. The arrows show the path of the radiation A, B and C. Answer the following question in terms of A, B and C.

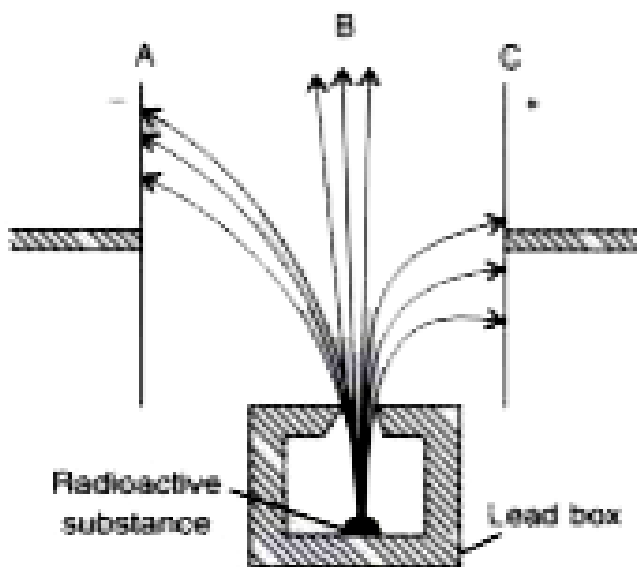

Which among the three causes the least biological damage extremely?



[Watch Video Solution](#)

42. Radiations given out from a source when subjected to an electric field in a direction perpendicular to their path are shown below in the diagram. The arrows show the path of the radiation A, B and C. Answer the following question in terms of A, B and C.

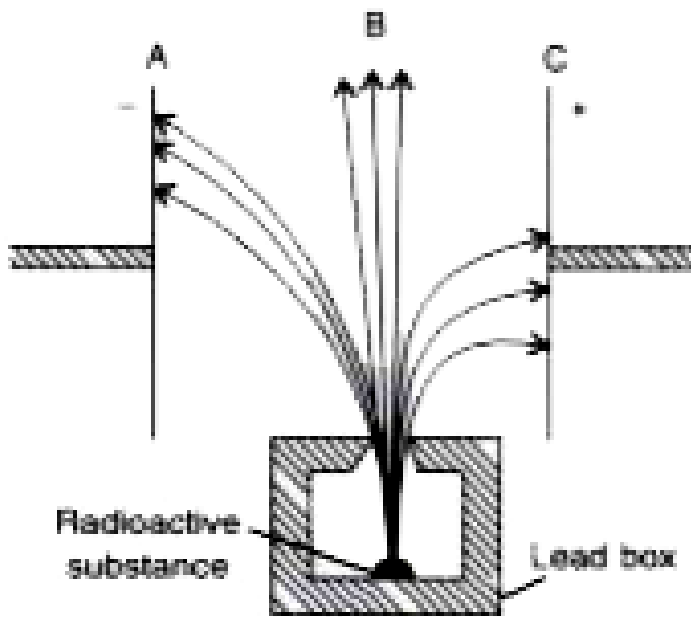

Name the radiation which is used in carbon dating.



[Watch Video Solution](#)