



PHYSICS

BOOKS - SELINA PHYSICS (ENGLISH)

SAMPLE PAPER 2020

Section I

1. Define moment of force and its unit.



Watch Video Solution

2. Write the relationship between the SI and CGS unit of moment of force.



[Watch Video Solution](#)

3. Define kilowatt hour. How is it related to joule?



[Watch Video Solution](#)

4. A satellite revolves around a planet in a circular orbit. What is the work done by the satellite at any instant ? Give a reason.



[Watch Video Solution](#)

5. Identify the class of the lever shown in the diagram below:



[Watch Video Solution](#)

6. How is it possible to increase the M. A. of the above lever without increasing its length ?



[Watch Video Solution](#)

7. Give one example of each when :

Chemical energy changes into electrical energy.



[Watch Video Solution](#)

8. Give one example of each when :

Electrical energy changes into sound energy.



[Watch Video Solution](#)

9. A crane 'A' lifts a heavy load in 5 seconds, whereas another crane 'B' does the same work in 2 seconds. Compare the power of crane 'A' to that of crane 'B'.



[Watch Video Solution](#)

10. A ray of light falls normally on a rectangular glass slab.

Draw a ray diagram showing the path of the ray till it emerges out of the slab.



Watch Video Solution

11. Complete the path of the monochromatic light ray AB incident on the surface PQ of the equilateral glass prism PQR till it emerges out

of the prism due to refraction.

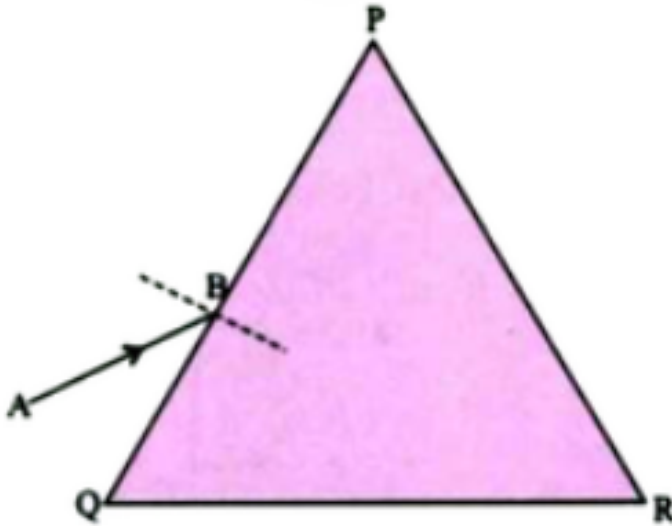

 [Watch Video Solution](#)

12. Where should an object be placed in front of a convex lens in order to get :
an enlarged real image



[Watch Video Solution](#)

13. Where should an object be placed in front of a convex lens in order to get :
enlarged virtual image ?



[Watch Video Solution](#)

14. A pond appears to be 2.7 m deep. If the refractive index of water is $\frac{4}{3}$, find the actual depth of the pond.



[Watch Video Solution](#)

15. The wave lengths for the light of red and blue colours are nearly $7.8 \times 10^{-7}m$ and $4.8 \times 10^{-7}m$ respectively.

Which colour has the greater speed in a vacuum ?



[Watch Video Solution](#)

16. The wave lengths for the light of red and blue colours are nearly

$7.8 \times 10^{-7}m$ and $4.8 \times 10^{-7}m$ respectively.

Which colour has the greater speed in a vacuum ?



[Watch Video Solution](#)

17. Draw a graph between displacement from mean position and time for a body executing free vibration in a vacuum.



[Watch Video Solution](#)

18. A sound wave travelling in water has wavelength 0.4 m.

Is this wave audible in air ? (The speed of sound in water = 1400ms^{-1})



Watch Video Solution

19. Why does stone lying in the sun get heated up much more than water lying for the same duration of time ?



Watch Video Solution

20. Why is it not advisable to use a piece of copper wire as fuse wire in an electric circuit ?

 [Watch Video Solution](#)

21. Calculate the total resistance across AB:

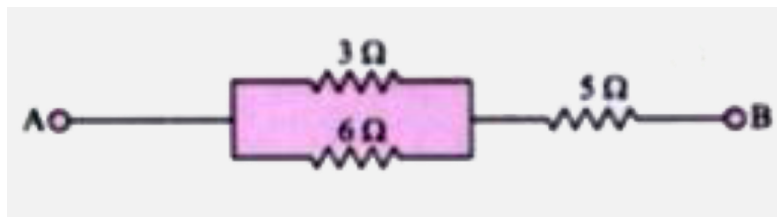

 [Watch Video Solution](#)

22. Two metallic blocks P and Q having masses in ratio 2 : 1 are supplied with the same amount of heat. If their temperatures rise by same degree, compare their specific heat capacities.



Watch Video Solution

23. When a current carrying conductor is placed in a magnetic field, it experiences a mechanical force. What should be the angle between the magnetic field and the length of

the conductor so that the force experienced is

:

(i) Zero

(ii) Maximum ?



Watch Video Solution

24. A nucleus ${}_{84}X^{202}$ of an element emits an alpha particle followed by a beta particle. The final nucleus is ${}_aY^b$. Find a and b.



Watch Video Solution

25. The diagram below shows a loop of wire carrying current I :

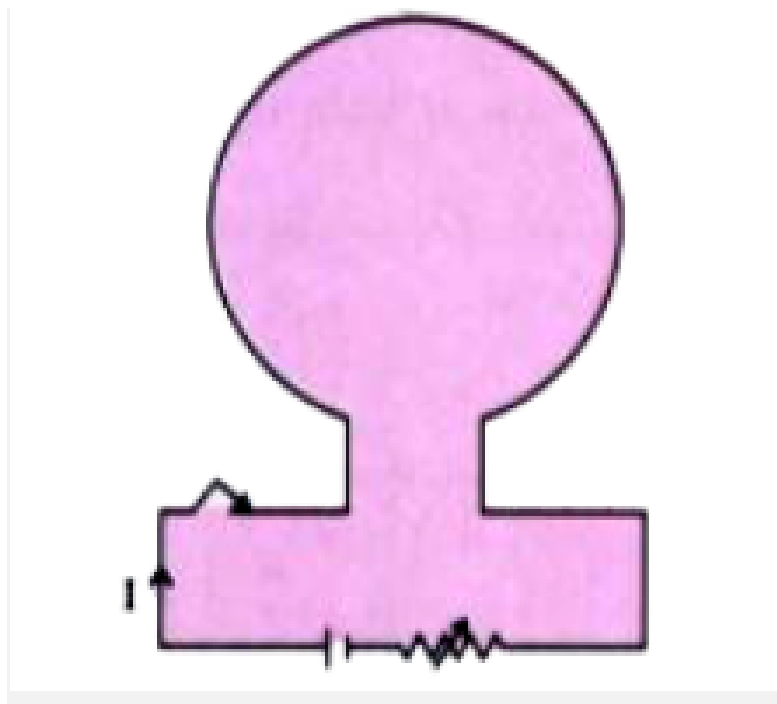

What is the magnetic polarity of the loop that faces us?



Watch Video Solution

26. The diagram below shows a loop of wire carrying current I :

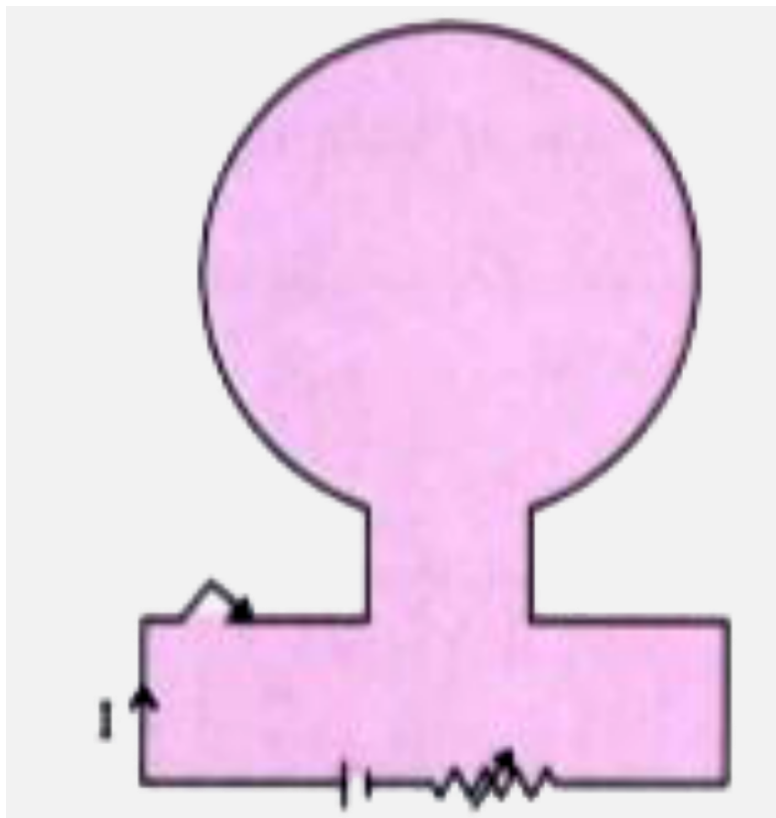

With respect to the diagram how can we increase the strength of the magnetic field produced by this loop ?



[Watch Video Solution](#)

27. Write the SI unit of heat capacity.



[Watch Video Solution](#)

28. What is the relationship between heat capacity and specific heat capacity of a substance ?



[Watch Video Solution](#)

29. The diagram below shows the change of phases of a substance on a temperature vs time graph on heating the substance at a constant rate.



Why is the slope of CD less than slope of AB ?



Watch Video Solution

30. The diagram below shows the change of phases of a substance on a temperature vs time graph on heating the substance at a

constant rate.

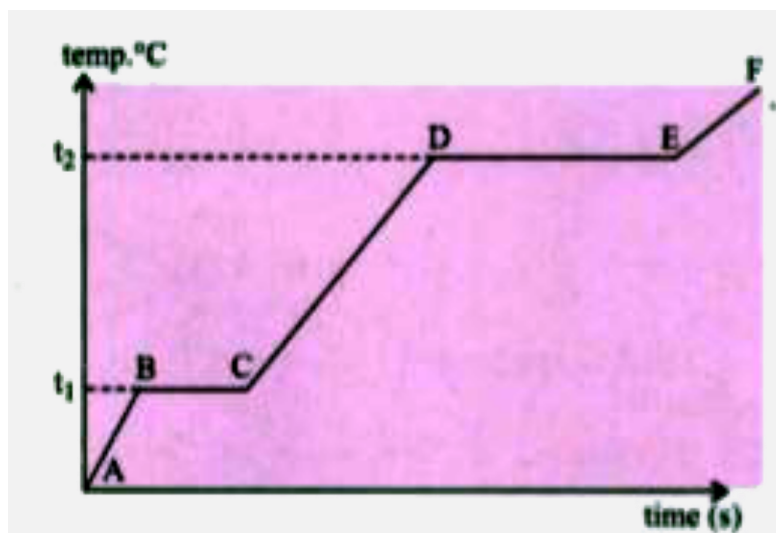

What is the boiling and melting point of the substance ?



[Watch Video Solution](#)

31. A piece of ice of mass 60 g is dropped into 140 g of water at $50^{\circ}C$.

Calculate the final temperature of water when all the ice has melted.

(Assume no heat is lost to the surrounding)

Specific heat capacity of water = $4.2Jg^{-1}k^{-1}$

Specific latent heat of fusion of ice = $336Jg^{-1}$



[Watch Video Solution](#)

32. Draw neat labeled diagram of a d.c. motor.



[Watch Video Solution](#)

33. Write any one use of a d.c motor.



Watch Video Solution

34. Differentiate between nuclear fusion and nuclear fission.



Watch Video Solution

35. State one safety precaution in the disposal of nuclear waste.



Watch Video Solution

36. An atomic nucleus A is composed of 84 protons and 128 neutrons. The nucleus A emits an alpha particle and is transformed into a nucleus B.

(i) What is the composition of B ?

(ii) The nucleus B emits a beta particle and is transformed into a nucleus C. What is the composition of C?

(iii) What is mass number of the nucleus A ?

(iv) Does the composition of C change if it emits gamma radiations ?



[Watch Video Solution](#)

Section II

1. The figure below shows a simple pendulum of mass 200 g. It is displaced from the mean position A to the extreme position B. The potential energy at the position A is zero. At the position B the pendulum bob is raised by 5

m.

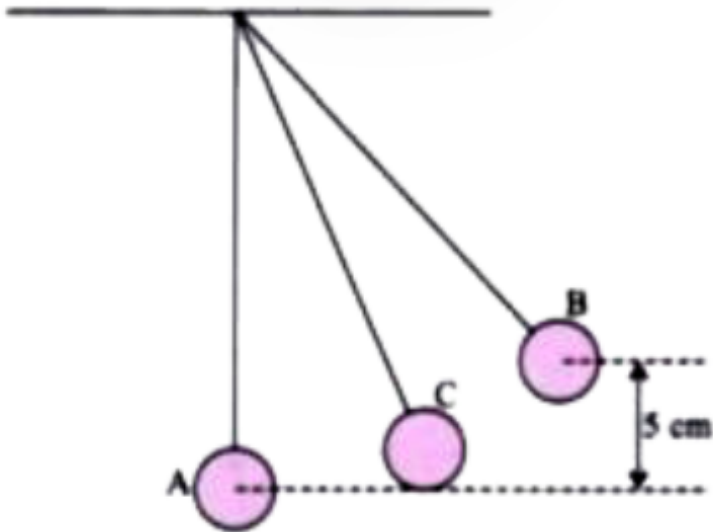

- (i) What is the potential energy of the pendulum at the position B?
- (ii) What is the total mechanical energy at point C?
- (iii) What is the speed of the bob at the position A when released from B ?

(Take $g = 10ms^{-2}$ and there is no loss of energy.)



Watch Video Solution

2. With reference to the direction of action, how does a centripetal force differ from a centrifugal during uniform circular motion ?



Watch Video Solution

3. Is centrifugal force the force of reaction of centripetal force ?



Watch Video Solution

4. Compare the magnitudes of centripetal and centrifugal force.



Watch Video Solution

5. A block and tackle system of pulleys has velocity ratio 4.

Draw a neat labelled diagram of the system indicating clearly the points of application and direction of load and effort.



[Watch Video Solution](#)

6. A block and tackle system of pulleys has velocity ratio 4.

What will be its V. R. if the weight of the movable block is doubled ?



[Watch Video Solution](#)

7. A diver in water looks obliquely at an object AB in air.

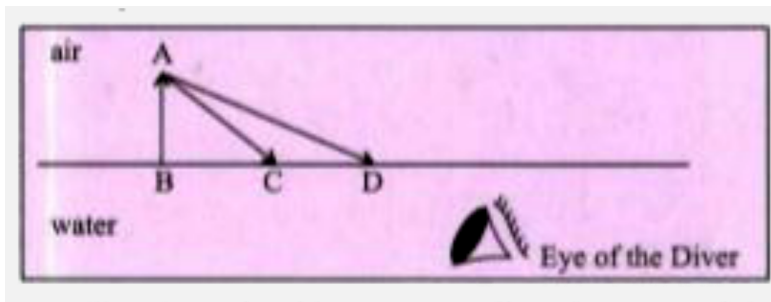

Does the object appear taller, shorter or of the same size to the diver?





Watch Video Solution

8. A diver in water looks obliquely at an object AB in air.

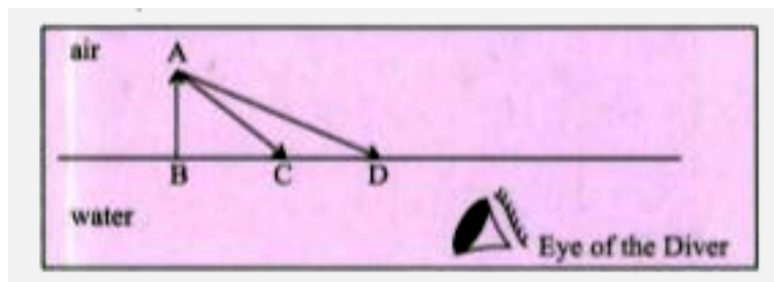

Show the path of two rays AC and AD starting from the tip of the object as it travels towards the diver in water and hence obtain the image of the object.



Watch Video Solution

9. Complete the path of the ray AB through the glass prism in PQR till it emerges out of the prism. Given the critical angle of the glass

as 42° .

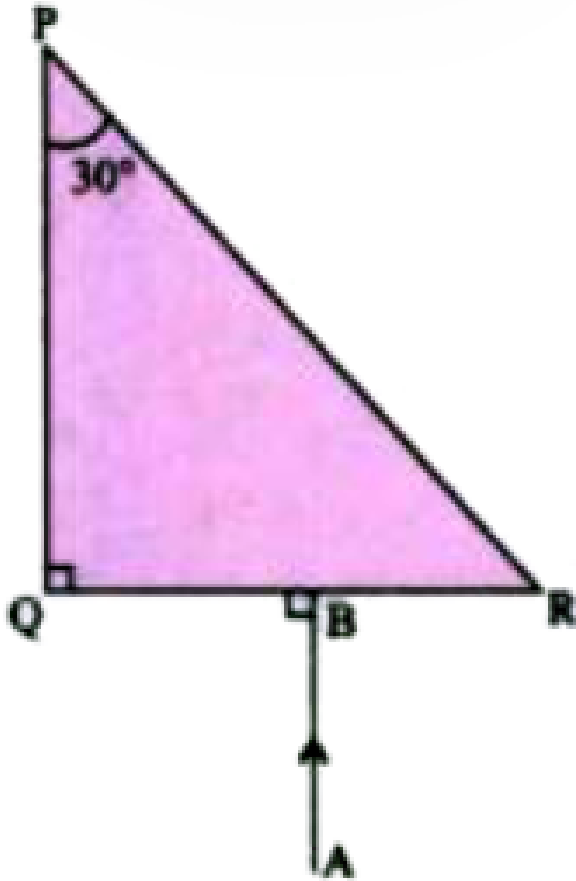

Watch Video Solution

10. A lens of focal length 20 cm forms an inverted image at a distance 60 cm from the lens.

(i) Identify the lens.

(ii) How far is the lens present in front of the object ?

(iii) Calculate the magnification of the image.



Watch Video Solution

11. Give reasons for the following:

During the day :

Clouds appear white.



Watch Video Solution

12. Give reasons for the following:

During the day :

Sky appears blue.



Watch Video Solution

13. Name the system which enables us to locate underwater objects by transmitting ultrasonic waves and detecting the reflecting impulse.



Watch Video Solution

14. What are acoustically measurable quantities related to pitch and loudness ?



Watch Video Solution

15. When a tuning fork (vibrating) is held close to ear, one hears a faint hum. The same (vibrating tuning fork) is held such that its stem is in contact with the table surface, then one hears a loud sound. Explain.



Watch Video Solution

16. A man standing in front of a vertical cliff fires a gun. He hears the echo after 3.5 seconds. On moving closer to the cliff by 84 m, he hears the echo after 3 seconds. Calculate

the distance of the cliff from the initial position of the man.



[Watch Video Solution](#)

17. The diagram below shows the core of a transformer and its input and output connections.

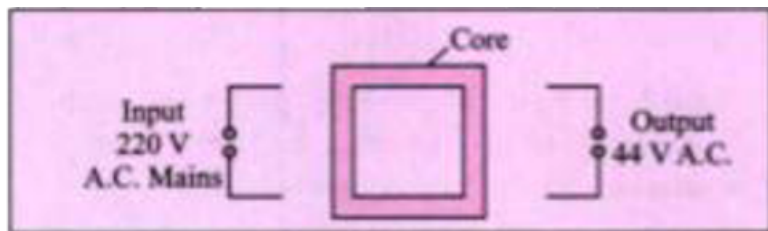

State the material used for the core.



[Watch Video Solution](#)

18. The diagram below shows the core of a transformer and its input and output connections.

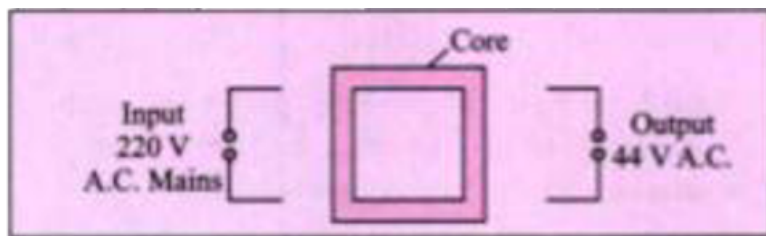

Copy and complete the diagram of the transformer by drawing input and output coils.



Watch Video Solution

19. Superconductors are:



Watch Video Solution

20. Calculate the current drawn by an appliance rated 110 W, 220 V when connected across 220 V supply.



Watch Video Solution

21. Name a substance whose resistance decreases with the increase in temperature.

 [Watch Video Solution](#)

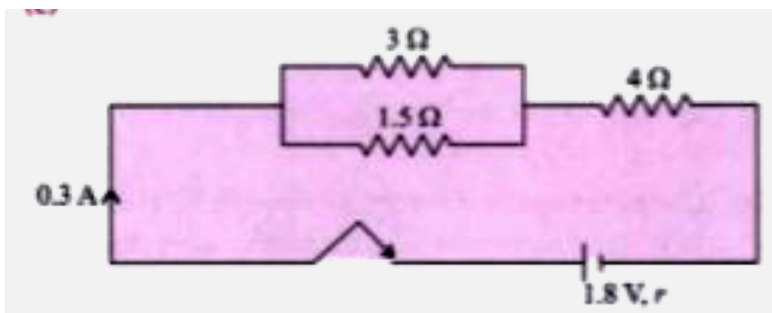

22.

The diagram above shows three resistors connected across a cell of e.m.f. 1.8 V and internal resistance r . Calculate :

Current through $3\ \Omega$ resistor.



Watch Video Solution

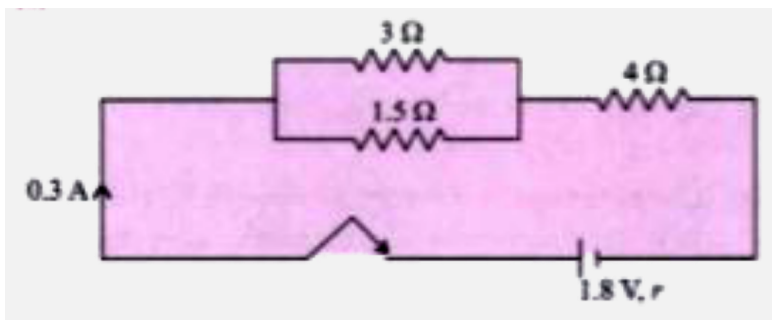

23.

The diagram above shows three resistors connected across a cell of e.m.f. 1.8 V and internal resistance r . Calculate :

The internal resistance r .



Watch Video Solution

24. Define heat capacity of a substance.



Watch Video Solution