



PHYSICS

BOOKS - CENGAGE PHYSICS (ENGLISH)

CENTRE OF MASS

Illustration

1. Four particles of masses $1kg$, $2kg$, $3kg$ and $4kg$ are placed the four vertices A , B , C and D , respectively, of a square of side $1m$. Find

the position of centre of mass of the particles.

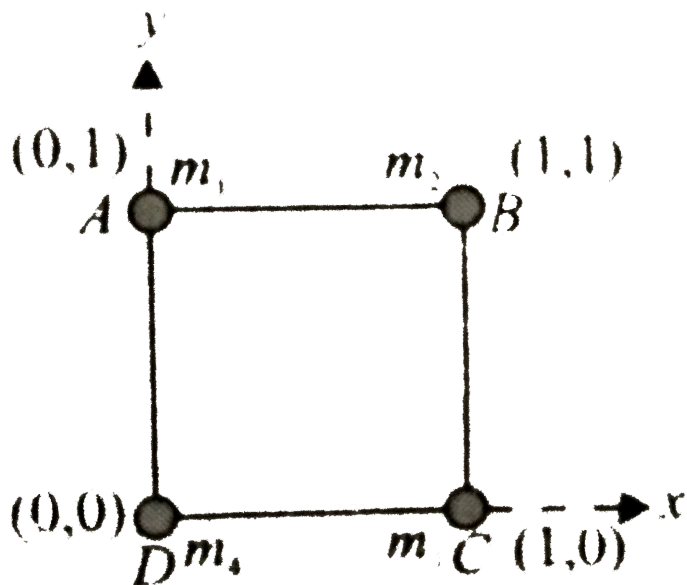

[Watch Video Solution](#)

2. Consider a two particle system with the particles having masses m_1 and m_2 . If the first particles pushed towards the centre of

mass through a distance d , by what distance should the second particle be moved so as to keep the centre of mass at the same position?



[Watch Video Solution](#)

3. Find the centre of mass of a uniform L-shaped lamina (a thin flat plate) with dimensions as shown. The mass of the lamina is 3 kg.



[Watch Video Solution](#)

4. Find the position of centre of mass of the uniform lamina shown in figure.

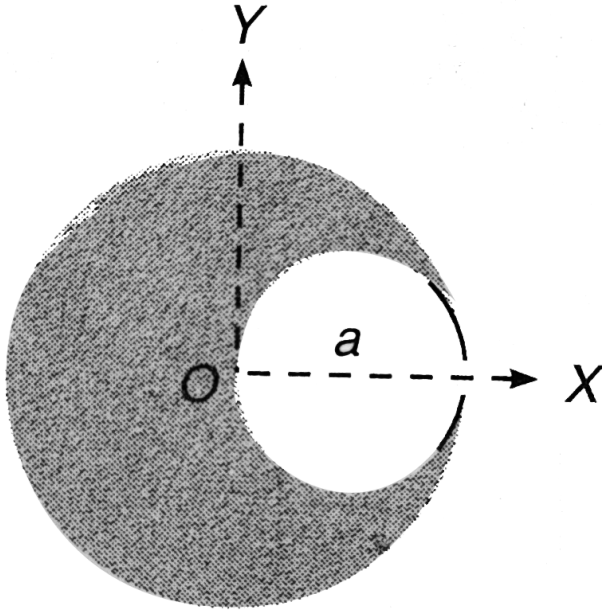
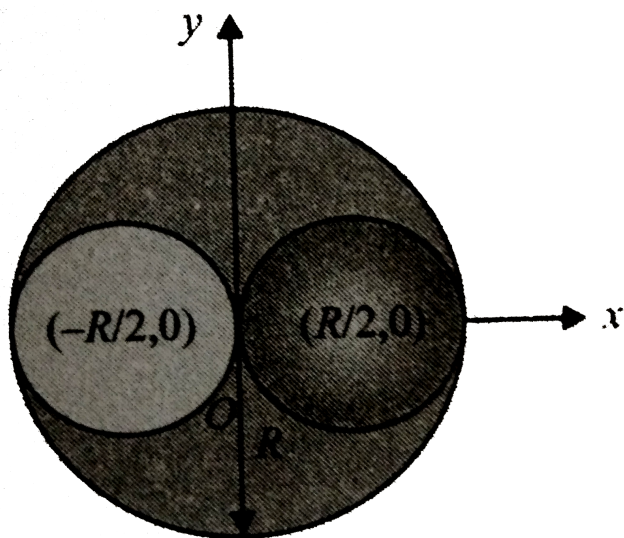

Fig 11 12



Watch Video Solution

5. Figure shows a uniform disc of radius R , from which a hole of radius $\frac{R}{2}$ has been cut out from left of the centre and is placed on the right of the centre of the disc. Find the CM of the resulting disc.



[Watch Video Solution](#)

6. A projectile is fired at a speed of 100 m/s at an angle of 37° above the horizontal. At the highest point, the projectile breaks into two parts of mass ratio $1:3$ the smaller coming to rest. Find the distance from the launching point to the where the heavier piece lands.

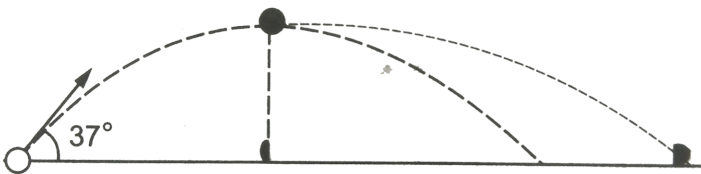

Watch Video Solution

7. Two balls with masses $m_1 = 3$ and $m_2 = 5$ kg have initial velocities $v_1 = v_2 = 5\text{ m/s}$ in the directions shown in figure. They collide at the origin.

a. find the velocity of the CM 3 s before the collision.

b. Find the position of the CM 2 s after the

collision.

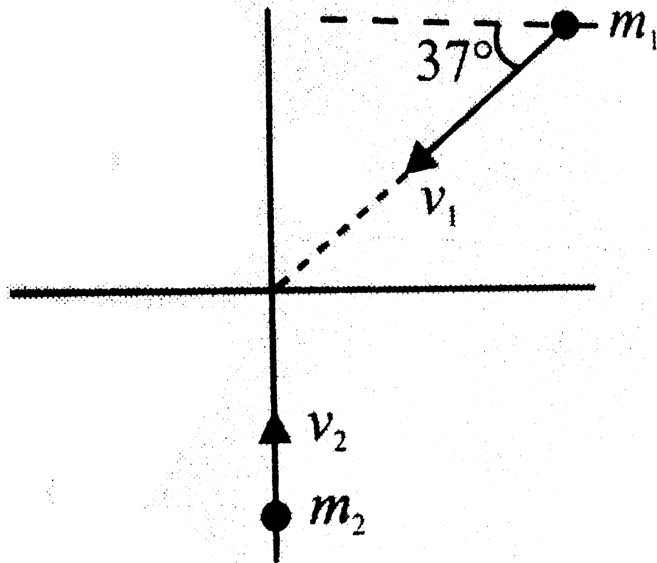

Watch Video Solution

8. Two masses nm and m , start simultaneously from the intersection of two straight lines with velocities v and nv respectively. It is observed

that the path of their centre of mass is a straight line bisecting the angle between the given straight lines. Find the magnitude of the velocity of centre of mass. [Here $\theta =$ angle between the lines]

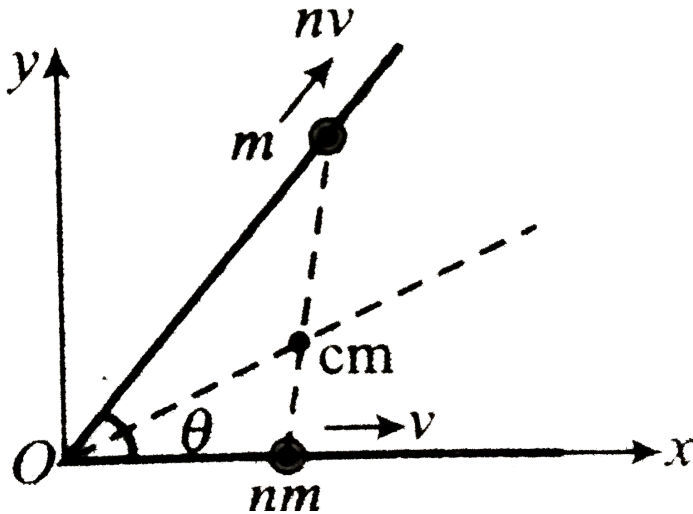

[Watch Video Solution](#)

9. Two blocks A and B each of equal masses m are released from the top of a smooth fixed wedge as shown in the figure. Find the magnitude of the acceleration of the centre of mass of the two blocks.

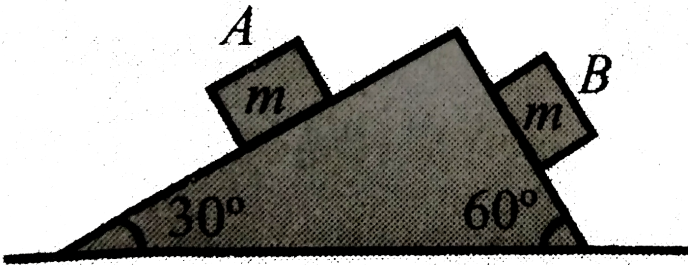

[Watch Video Solution](#)

10. Two particles of masses $2kg$ and $4kg$ are approaching towards each other with accelerations $1m/s^2$ and $2m/s^2$, respectively, on a smooth horizontal surface. Then find the acceleration of centre of mass of the system and direction of acceleration of CM.



Watch Video Solution

11. A pulley fixed to the ceiling carried a thread with bodies of masses m_1 and m_2 attached to its ends. The masses of the pulley and the

thread are negligible and friction is absent.

Find the acceleration of the centre of mass of this system.

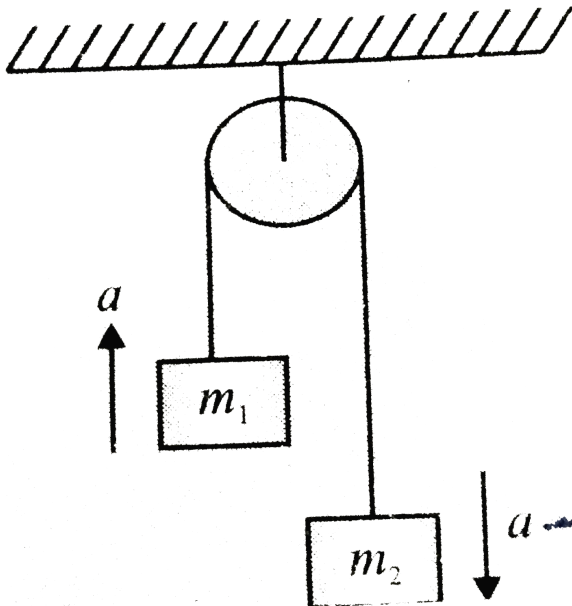

[Watch Video Solution](#)

12. A log of wood of length l and mass M is floating on the surface of a river perpendicular to the banks. One end of the log touches the banks. A man of mass m standing at the other end walks towards the bank. Calculate the displacement of the log when he reaches nearer end of the log



Watch Video Solution

13. A plank of mass M and length L is at rest on a frictionless floor. The top surface of the

plank has friction. At one end of it a man of mass m is standing as shown in figure. If the man walks towards the other end the find the distance, which the plank moves a till the man reaches the centre of the plank. b. till the man reaches the other end of the plank.

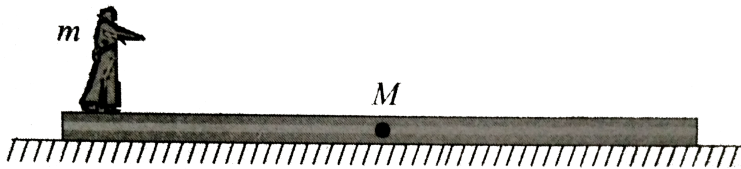

Watch Video Solution

14. An explosion blows a rock into three parts. Two pieces go off at right angles to each other, 1.0kg piece with velocity of 12m/s and other, 1.0kg piece with a velocity of 12m/s and other 2.0kg piece with a velocity of 8m/s . If the third piece flies off with a velocity of 40m/s compute the mass of the third piece.



Watch Video Solution

15. A uniform of mass m and length L is tied to a vertical shaft. It rotates in horizontal plane

about the vertical axis at angular velocity ω .

How much horizontal force does the shaft

exert on the rod?

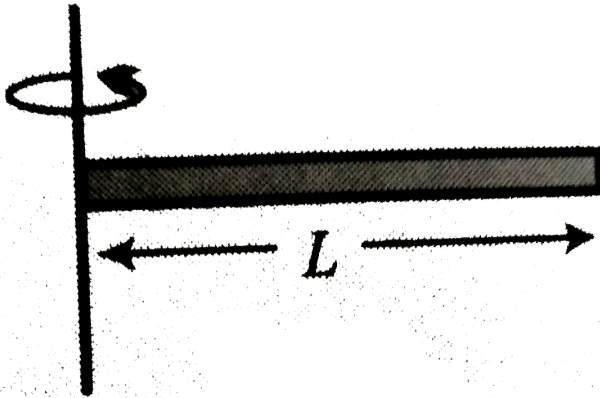

[Watch Video Solution](#)

16. Two balls of equal mass are projected upwards simultaneously, one from the ground

with initial velocity 50ms^{-1} and the other from a 40m tower with initial velocity of 30ms^{-1} . The maximum height attained by their COM will be a) 80 m b) 60 m c) 100 m d) 120 m



Watch Video Solution

17. A body of mass explodes at rest break up into three parts. If two parts having equal masses fly off perpendicularly to each other with a velocity of 18m/s , then calculate the

velocity of the third part which has a mass 3 times the mass of each part.



Watch Video Solution

18. A man of mass m moves on a plank of mass M with a constant velocity u with respect to the plank, as shown in figure.

a. If the plank rests on a smooth horizontal surface, determine the velocity of the plank.

b. If the man travels a distance L with respect to the plank, find the distance travelled by the

plank with respect to the ground.

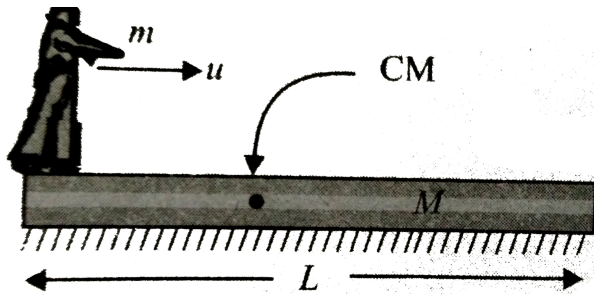

[Watch Video Solution](#)

19. A shell is fired from a cannon with a velocity V at an angle θ with the horizontal direction. At the highest point in its path, it explodes into two pieces of equal masses. One of the pieces retraces its path to the cannon. The speed of

the other piece immediately after the explosion is



[Watch Video Solution](#)

20. A man of mass m runs without sliding from rest from one end of a boat of mass M and length l with an acceleration a relative to the boat. If the friction between water and boat is neglected find the

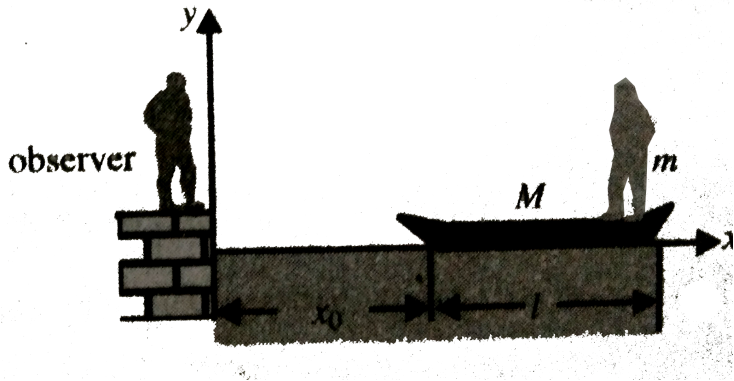

- acceleration of CM of the system ($M + m$)
- acceleration of the man and boat
- position of man at the time when he reaches to other end of the boat
- frictional force
- work done by friction on boat.
- total work done by friction.
- velocities of man and boat when the man

reaches other end of the boat.

h. work down by man



[Watch Video Solution](#)

21. Two trucks of mass M each are moving in opposite direction on adjacent parallel tracks with same velocity u . One is carrying potatoes and other is carrying onions, a bag of potatoes has a mass m_1 and a bag of onions has a mass m_2 (included in the mass of truck M). When trucks get close to each other while passing

the drivers exchange a bag with the other one by throwing the other one. Find the final velocities of the trucks after exchange of the bags.

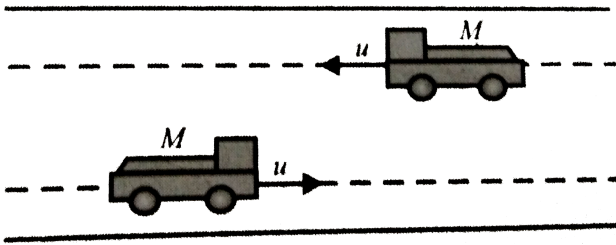

[Watch Video Solution](#)

22. A flat car of mass M is at rest on a frictionless floor with a child of mass m

standing at its edge. If the child jumps off from the car towards right with an initial velocity u , with respect to the car, find the velocity of the car after its jump.



[Watch Video Solution](#)

23. Two blocks of masses m_1 and m_2 interconnect with a spring of stiffness K , are kept on a smooth horizontal surface. Find out the ratio of velocity, displacement, kinetic

energy and acceleration block with mass m_1 of block with mass m_2 .



[Watch Video Solution](#)

24. Two identical buggies move one after the other due to inertia (without friction) with the same velocity v_0 . A man of mass m rides the rear buggy. At a certain moment the man jumps into the front buggy with a velocity u relative to his buggy. Knowing that the mass of

each buggy is equal to M , find the velocities with which the buggies will move after that.



[Watch Video Solution](#)

25. A flat car of mass m is at rest on a frictionless floor with a child of mass m standing at its edge. If the child jumps off from the car towards right with an initial velocity u , with respect to the car, find the velocity of the car after its jump.



[Watch Video Solution](#)

26. A light spring of spring constant k is kept compressed between two blocks of masses m and M on a smooth horizontal surface. When released, the blocks acquire velocities in opposite directions. The spring loses contact with the blocks when it acquires natural length. If the spring was initially compressed through a distance d find the final speeds of

the two blocks.

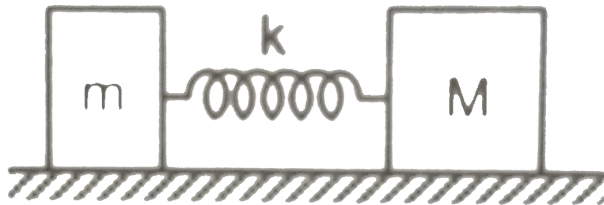

[Watch Video Solution](#)

27. A block of mass m is connected to another block of mass M by a massless spring of spring constant k . The blocks are kept on a smooth horizontal plane and are at rest. The spring is unstretched when a constant force F starts acting on the block of mass M to pull it.

Find the maximum extension of the spring

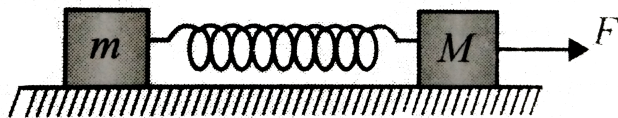

 [Watch Video Solution](#)

28. Two small discs of masses m_1 and m_2 are connected by a weightless spring resting on a smooth horizontal plane. The discs are set in motion with initial velocities v_1 and v_2 whose directions are mutually perpendicular and in the same horizontal plane. Find the total

energy E of the system with reference to the frame fixed to the centre of mass.

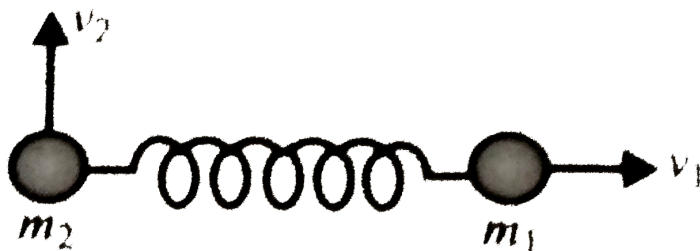

[Watch Video Solution](#)

29. Two smooth blocks of masses m_1 and m_2 attached with an ideal spring of stiffness k and kept on horizontal surface. If m_1 is projected with a horizontal velocity v_0 . Find the

maximum compression of the spring.

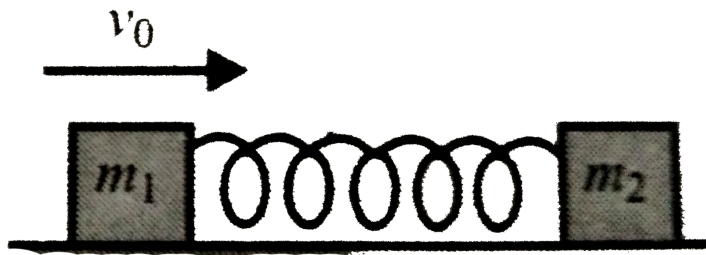

[Watch Video Solution](#)

30. A block of mass m is pushed with a velocity v_0 along the surface of a trolley car of mass M . If the horizontal ground is smooth and the coefficient of kinetic friction between the block

of plank is μ . Find the minimum distance of relative sliding between the block and plank.

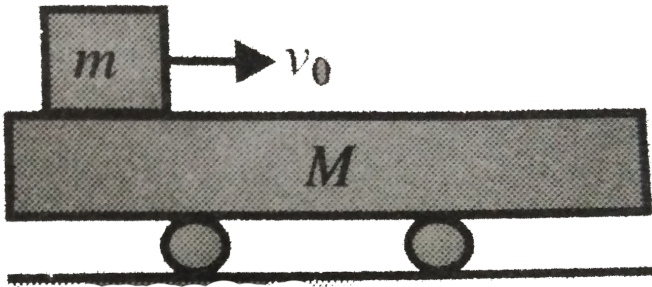

[Watch Video Solution](#)

31. A smooth wedge of mass M rests on a smooth horizontal surface. A block of mass m is projected from its lowermost point with

velocity v_0 . What is the maximum height reached by the block?

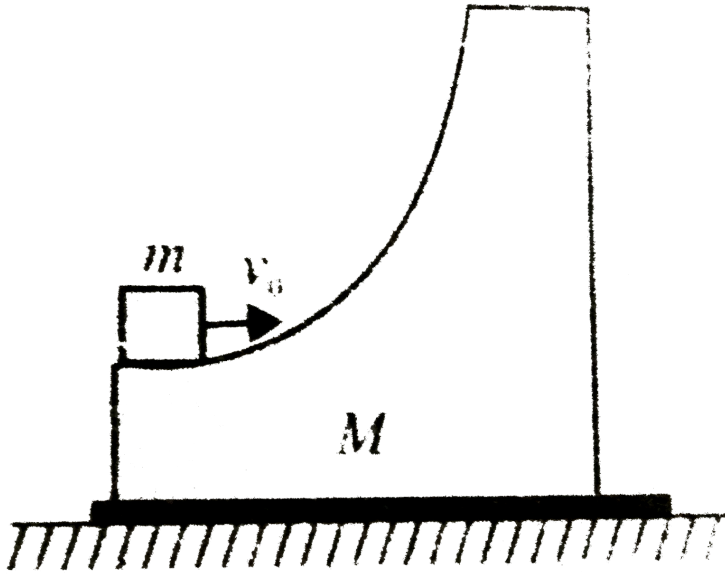

Watch Video Solution

32. The hero of a stunt film fires 50 g bullets from a machine gun, each at a speed of 1.0 km/s. If he fires 20 bullets in 4 seconds. What average force does he exert against the machine gun during this period?



Watch Video Solution

33. A block of mass m and a pan of equal mass are connected by a string going over a smooth light pulley as shown in figure. Initially the system is at rest when a particle of mass m

falls on the pan and sticks to it. If the particle strikes the pan with a speed v find the speed with which the system moves just after the collision.



[Watch Video Solution](#)

34. Two identical blocks A and B connected by massless string, are placed on a frictionless horizontal plane. A bullet having the same mass, moving with speed u strikes block B from behind as shown. If the bullet gets embedded

into block B then find

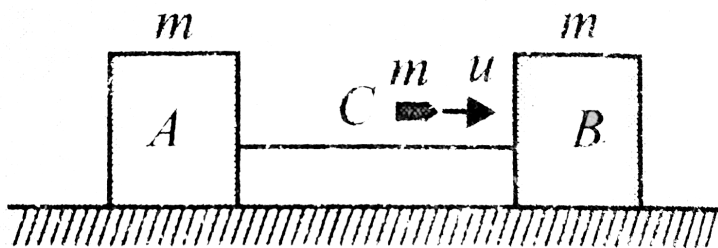

- the velocity of A , B , C after collision.
- impulse on A due to tension in the string,
- impulse on C due to normal force of collision,
- impulse on B due to normal force of collision.



[Watch Video Solution](#)

35. A ball of mass 1kg is attached to an inextensible string. The ball is released from the position shown in figure. Find the impulse imparted by the string to the ball immediately after the string becomes taut. (Take

$$g = 10 \text{ m/s}^2$$

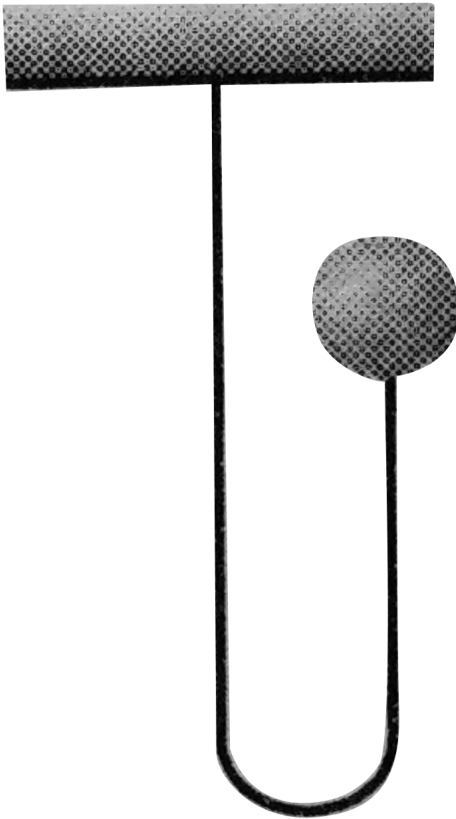

Watch Video Solution

36. Two particles A and B each of mass m are attached by a light inextensible string of length $2l$. The whole system lies on a smooth horizontal table with B initially at a distance l from A. The particle at end B is projected across the table with speed u perpendicular to AB. Velocity of ball A just after the string is

taur , is

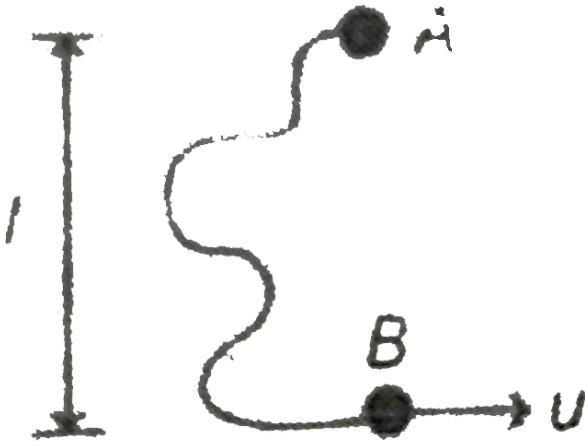

Watch Video Solution

37. A sphere of mass m slides with velocity v on a frictionless surface towards a smooth inclined wall as shown in figure. If the collision

with the wall is perfectly elastic find a. the impulse imparted by the wall on the sphere b the impulse imparted by the floor on the sphere.

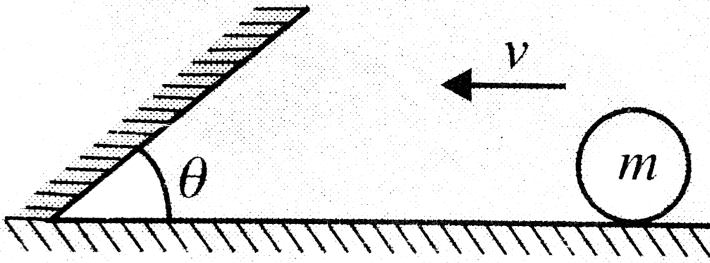

[Watch Video Solution](#)

38. A mass $2m$ rests on a horizontal table. It is attached to a light inextensible string which

passes over a smooth pulley and carries a mass m is raised vertically through a distance h and is then dropped, then the speed with which the mass $2m$ begins to rise is

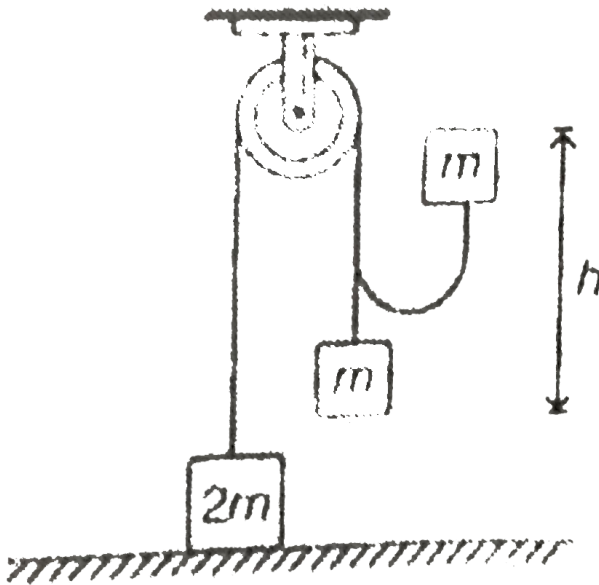

[Watch Video Solution](#)

39. Two particles of masses m_1 and m_2 are connected by a light and inextensible string which passes over a fixed pulley. Initially, the particle m_1 moves with velocity v_0 when the string is not taut. Neglecting friction in all contacting surface, find the velocities of the particles m_1 and m_2 just after the string is taut.

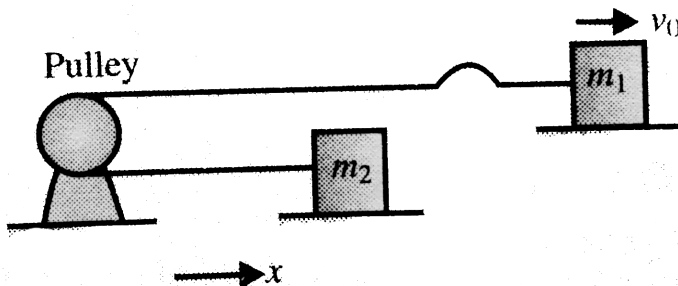

[Watch Video Solution](#)

40. A ball is projected from a given point with velocity u at some angle with the horizontal and after hitting a vertical wall returns to the same point. Show that the distance of the point from the wall must be less than $\frac{eu^2}{(1+e)g}$, where e is the coefficient of restitution.



Watch Video Solution

41. What will be the angle of reflection in case of an inelastic collision and $v = ?$



Watch Video Solution

42. If a ball strikes with a velocity u_1 at the wall which itself is approaching it with a velocity u_2 then find the velocity of the ball after collision with the wall.



Watch Video Solution

43. A tennis ball bounces down a flight of stairs striking each step in turn and rebounding to the height of the step above . The coefficient of restitution is



Watch Video Solution

44. A ball of a mass m hits the floor with a speed v making an angle of incidence θ with the normal. The coefficient of restitution is e . Find the speed of the reflected ball and the

angle of reflection of the ball.

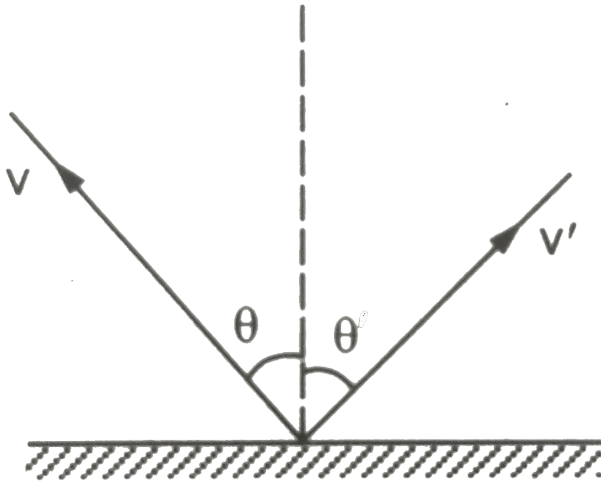

[Watch Video Solution](#)

45. Two identical balls are approaching towards each other on a straight line with velocity $2m/s$ and $4m/s$, respectively. Find the

final velocities after elastic collision between them.

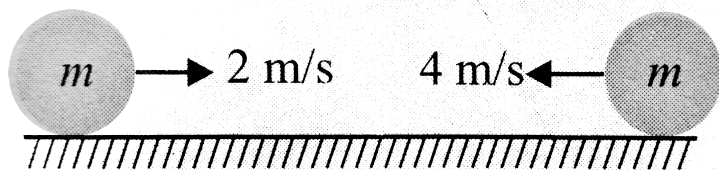

A. fig

B.

C.

D.



Watch Video Solution

46. Three balls A , B and C of same mass m are placed on a frictionless horizontal plane in a straight line as shown. Ball A is moved with velocity u towards the middle ball B . If all the collisions are elastic, find the final velocities of all the balls.

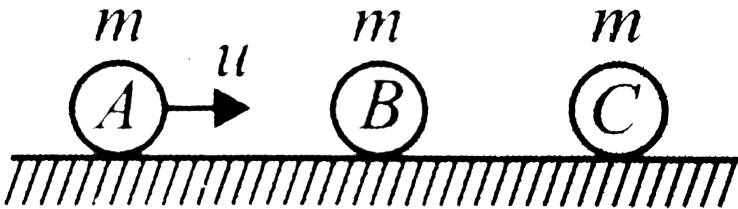

Watch Video Solution

47. Four identical balls A, B, C and D are placed in a line on frictionless horizontal surface. A and D are moved with the same speed u towards the middle as shown. Assuming elastic collisions, find the final velocities.

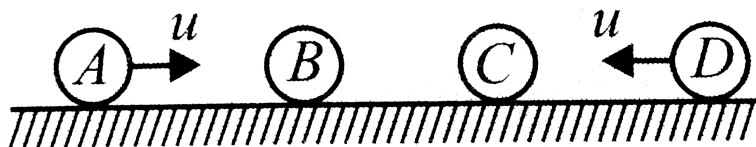

Watch Video Solution

48. Two particles of masses m and $2m$ moving in opposite directions collide elastically with velocity $2v$ and v , respectively. Find their velocities after collision.



 [Watch Video Solution](#)

49. A ball of mass m moving at a speed v makes a head on inelastic collision with an identical

ball at rest. The kinetic energy of the balls after the collision is $\frac{3}{4}$ th of the original. Find the coefficient of restitution.

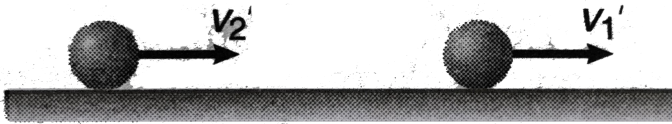
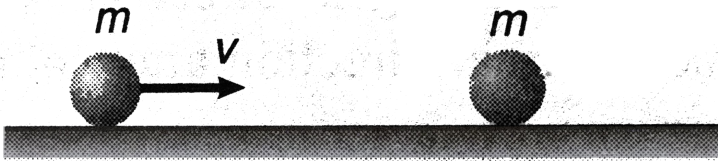

Watch Video Solution

50. A ball is moving with velocity 2ms^{-1} towards a heavy wall moving towards the ball speed 1ms^{-1} as shown in figure. Assuming collision to be elastic, find the velocity of ball immediately after the collision

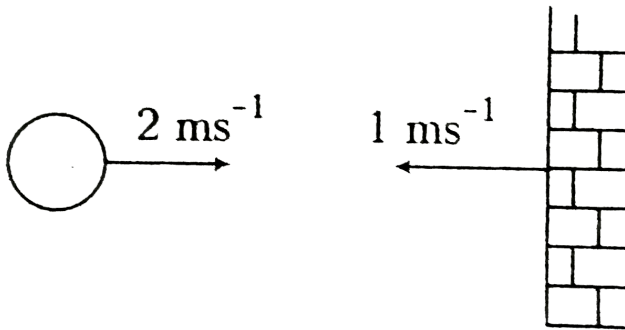

[Watch Video Solution](#)

51. Two balls of masses 2kg and 4kg are moved towards each other with velocities 4m/s and 2m/s , respectively, on a frictionless surface. After colliding, the 2kg ball returns back with velocity 2m/s . then find

- velocity of the 4kg after collision
- coefficient of restitution e ,
- impulse of deformation J_D
- maximum potential energy of deformation,
- impulse of reformation J_R

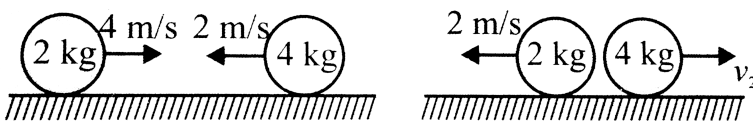

52. Two point particles A and B are placed in line on frictionless horizontal plane. If particle A (mass 1kg) is move with velocity 10m/s towards stationary particle B (mass 2kg) and after collision the two move at an angle of 45° with the initial direction of motion, then find

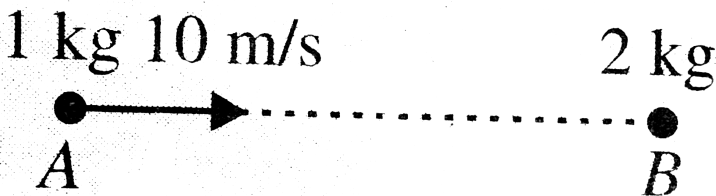

- velocites of A and B just after collision.
- coefficient of restitution



Watch Video Solution

53. A bullet of mass 50g is fired from below into the bob of mass 450g of a long simple pendulum as shown in Fig. The bullet remains inside the bob and the bob rises through a height of 1.8m. Find the speed of the

bullet. Take $g = 10 \frac{m}{s^2}$

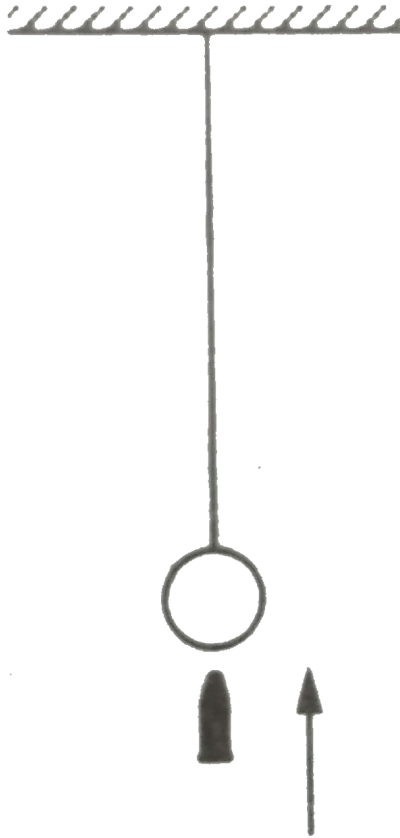

Watch Video Solution

54. A small ball of mass m collides with a rough wall having coefficient of friction μ at an angle θ with the normal to the wall. If after collision the ball moves with angle α with the normal to the wall and the coefficient of restitution is e , then find the reflected velocity

v of the ball just after collision.

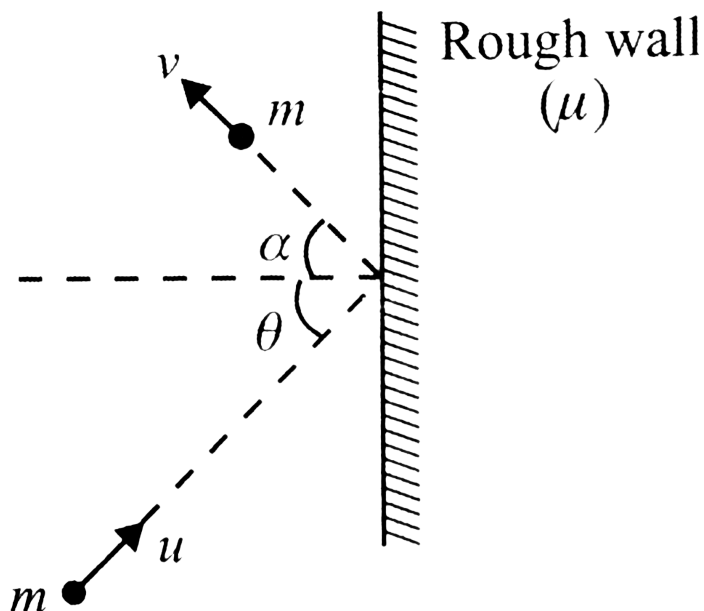

Watch Video Solution

55. Two equal spheres of mass m are in contact on a smooth horizontal table. A third identical sphere impinges symmetrically on the

and is reduced to rest. Prove that $e = \frac{2}{3}$ and find the loss in KE .



[Watch Video Solution](#)

56. A particle (a mud pallet, say) of mass m strikes a smooth stationary wedge of mass M with as velocity v_0 at an angle θ with horizontal. If the collision is perfectly inelastic, find the

- velocity of the wedge just after the collision.
- Change in KE of the system $(M + m)$ in

collision.

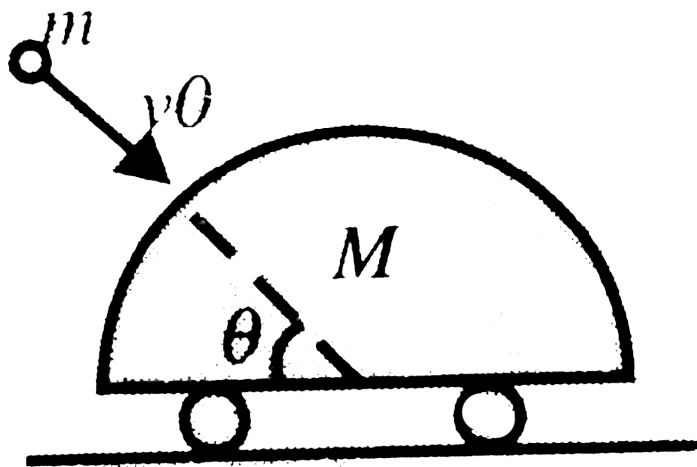

[Watch Video Solution](#)

57. A ball of mass m moving horizontally with velocity u hits a wedge of mass M . The wedge is situated on a smooth horizontal surface. If after striking with wedge the ball starts

moving in vertical direction and the wedge starts moving in horizontal plane. calculate

a. the velocity of wedge V .

b. the velocity (v) at which the ball moves in vertical direction.

c. the impulse imparted by the ball on the wedge.

d. the coefficient of restitution $e = ?$

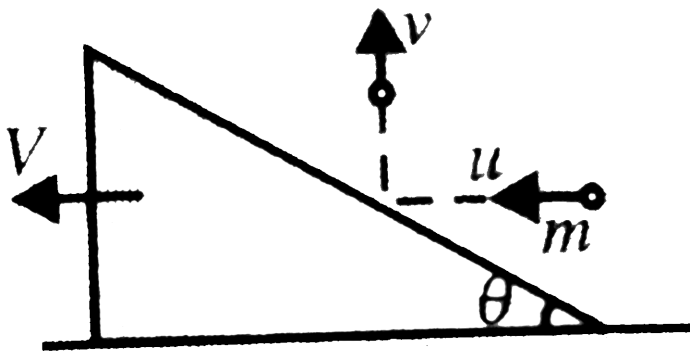

Watch Video Solution

58. A wedge of mass M is kept at rest on smooth surface a particle of mass m hits the wedge normally. Find the velocity of wedge and particle just after collision. Take coefficient of restitution as e .



Watch Video Solution

59. A flatcar of mass m_0 starts moving to the right due to a constant horizontal force

F(figure). Sand spills on the flatcar from a stationary hopper. The velocity of loading is constant and equal to $\mu kg/s$. Find the time dependence of the velocity and the acceleration of the flatcar in the process of loading. The friction is negligibly small.

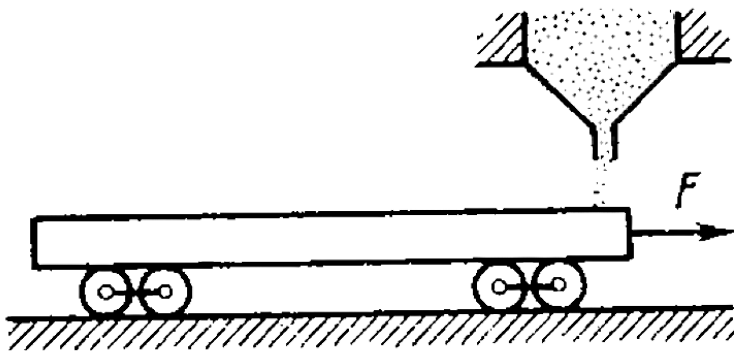



Watch Video Solution

60. A cart loaded with sand moves along a horizontal floor due to a constant force F coinciding in direction with cart's velocity vector. In the process, the sand spills through a hole in the bottom with a constant rate $\mu \text{ kg/s}$. Find the acceleration and velocity of the cart at the moment t , if at the initial moment $t = 0$ the cart with loaded sand had mass m_0 and its velocity was equal to zero. Friction is to be neglected.



[Watch Video Solution](#)

61. A rocket with an initial mass of 1000kg , is launched vertically upward from rest under gravity. The rocket burns fuel at the rate of 10kg per second. The burnt matter is ejected vertically downwards with a speed of 2000m/s relative to the rocket. Find the velocity of the rocket after 1 min of start.



[Watch Video Solution](#)

Solved Examples

1. A body of mass 1kg initially at rest, explodes and breaks into three fragments of masses in the ratio $1:1:3$. The two pieces of equal mass fly off perpendicular to each other with a speed of 15m.s^{-1} each. What is the velocity of the heavier fragment?



[Watch Video Solution](#)

2. A wedge of mass m_2 is kept on a spring balance. A small block of mass m_1 can move along the frictionless incline of the wedge. What is the reading of the balance while the block slides? Ignore the recoil of the wedge.

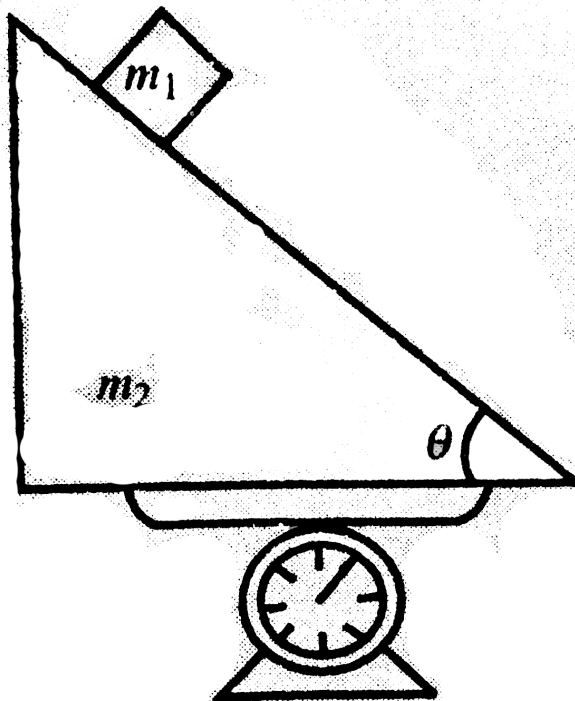

3. A spring is connected with plank and other end of spring is connected with a block of mass m . initially spring is stretched by a distance x_0 and block is connected with a thread which is connected to other end of the plank as shown. If thread is cut, what will be maximum speed of the plank.

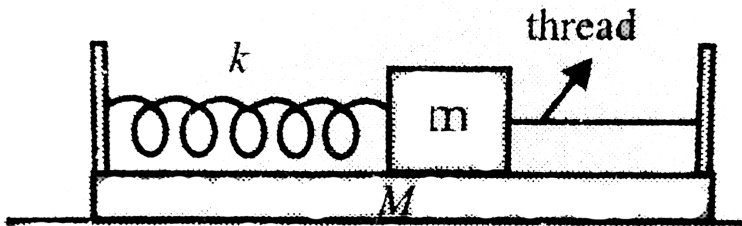



Watch Video Solution

4. A wedge having a vertical slot in it is placed on smooth horizontal surface as shown in the figure. Two blocks are arranged as shown in the figure. The system is released from rest calculate the speed of the wedge when block 1

comes down a distance h .

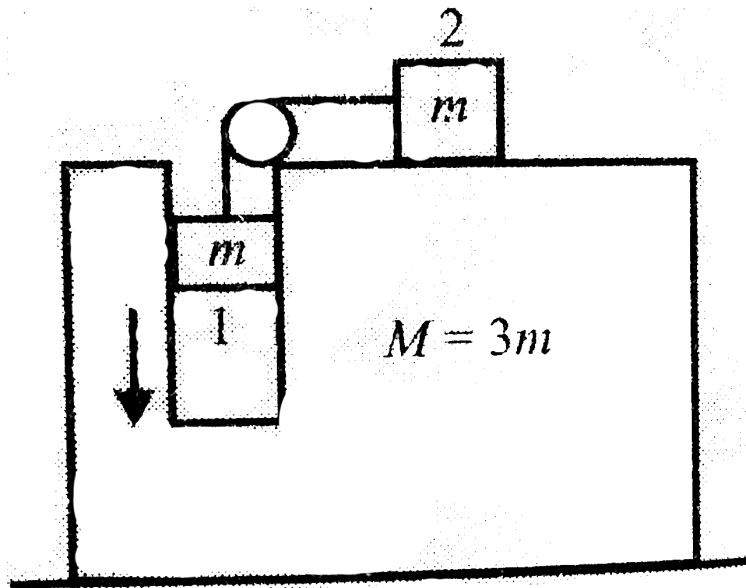

[Watch Video Solution](#)

5. A rope thrown over a pulley has a man of mass m on one of its ends and a counterbalancing mass M on its other end. The man whose mass is m ,

climbs upwards by $\overrightarrow{\Delta r}$ relative to the ladder and then stops. Ignoring masses of the pulley and the rope, as well as the friction the pulley axis, find the displacement of the centre of mass of this system.



[Watch Video Solution](#)

6. A block of mass m is released from rest from a height h onto a smooth surface of mass M fitted with an ideal spring of stiffness k . find

the maximum compression in the spring.

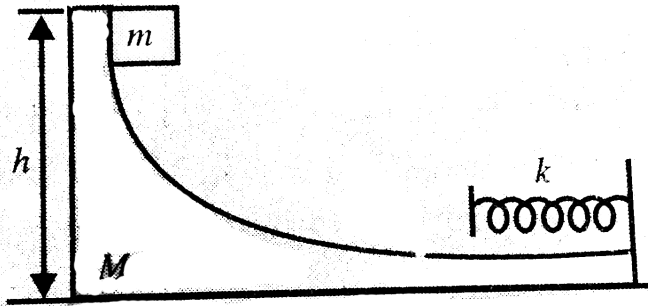

[Watch Video Solution](#)

7. A particle of mass m_1 is projected to the right with speed v_1 onto a smooth wedge of mass m_2 which is simultaneously projected due the left with a speed v_2 . If the particle attains

the highest point of the wedge, find h .

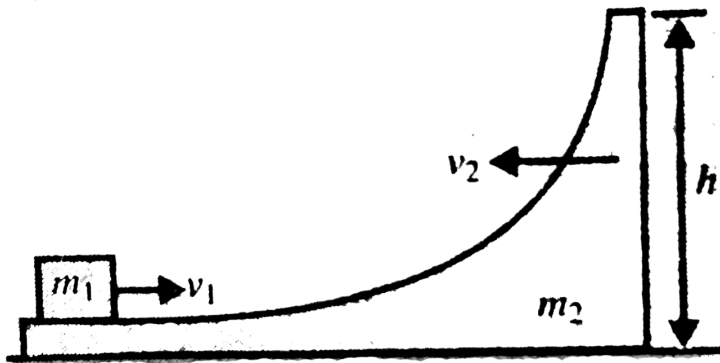

[Watch Video Solution](#)

8. A small ball of mass m is projected with a minimum horizontal velocity v_0 on a smooth wedge of mass M so that it will reach the highest point of the wedge. Find the value of

v_0

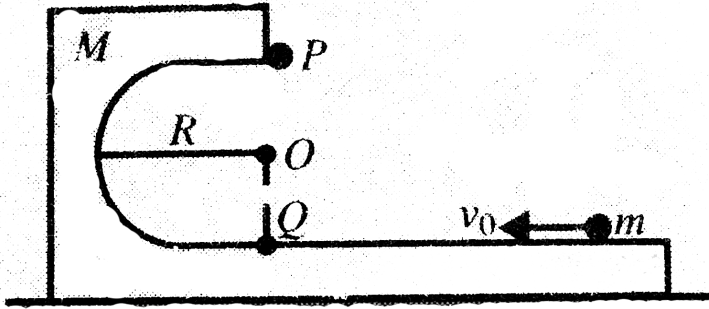

Watch Video Solution

9. A block is released on the convex surface of a hemispherical wedge as shown in Fig. Determine the displacement of the wedge

when the block reaches the angular position θ

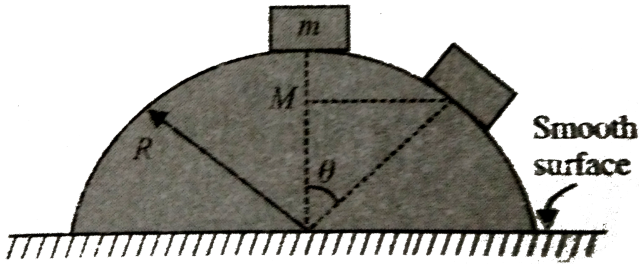

[Watch Video Solution](#)

10. There are two pendulums with bobs having identical size and mass. The pendulum A is released from rest in the position as shown in the figure. If the maximum angle formed by cord BO' with vertical in the subsequent

motion of sphere B is equal to the angle θ_0 . If the coefficient of restitution between sphere A and sphere B is e , find

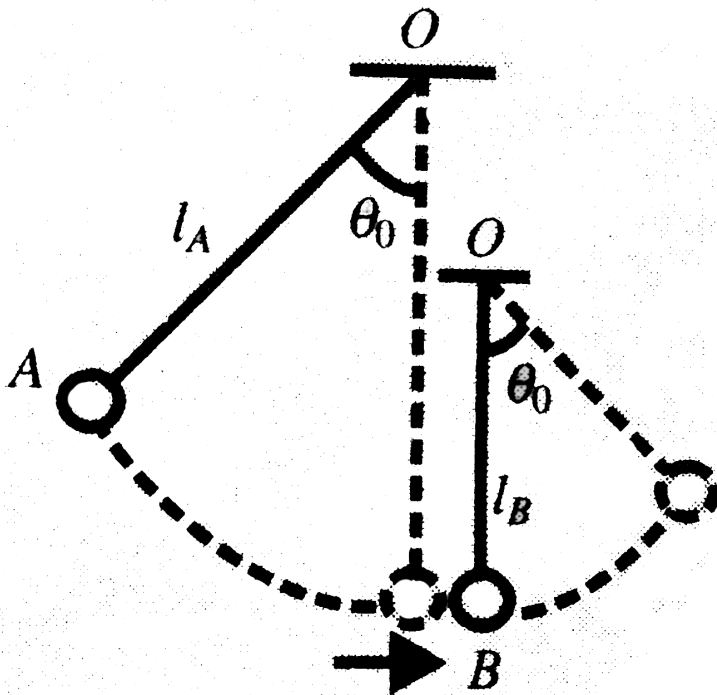

- the velocities of sphere A and sphere B just after collisions
- the ratio of lengths of pendulums l_B/l_A .



11. An empty luggage carrier A of mass $M = 40\text{kg}$ slide without friction on horizontal floor hits with a velocity $v_0 = 5\text{ms}^{-1}$ an identical carrier B containing $m=15$ kg suitcase. The impact causes the suitcase to slide on the floor of carrier B and collide with the left wall of carrier B . knowing that the coefficient of restitution between the two carriers is 0.80 and that the coefficient of restitution between the suitcase and the wall

of carrier B is $2/9$. Assume no friction any where. Find

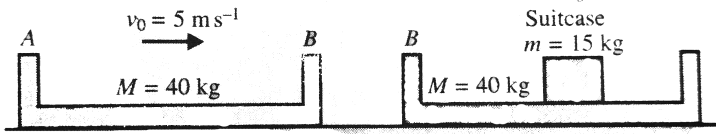

- the velocities of carrier A and carrier B just after collision.
- the velocity of carrier B after the suitcase hits the wall for the first time is



[Watch Video Solution](#)

12. A ball of mass m is pushed with a horizontal velocity v_0 from one end of a sledge

of mass M and length l . if the ball stops after its first collision with the sledge, find the speeds of the ball and sledge after the second collision of the ball with the sledge.

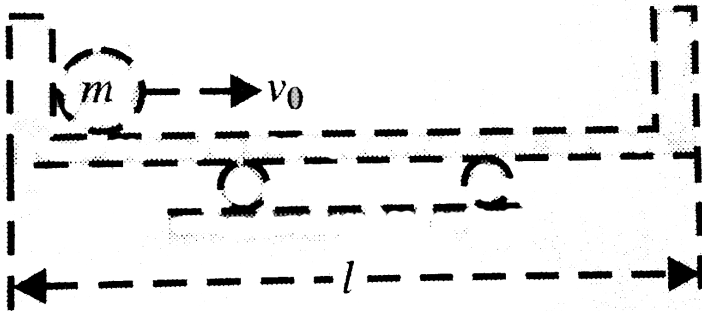

[Watch Video Solution](#)

13. Two spherical bodies of mass m_1 and m_2 fall freely through a distance h . before the

body m_2 collides with the ground. If the coefficient of restitution of all collisions is e , find the velocity of m_1 just after it collides with

m_2

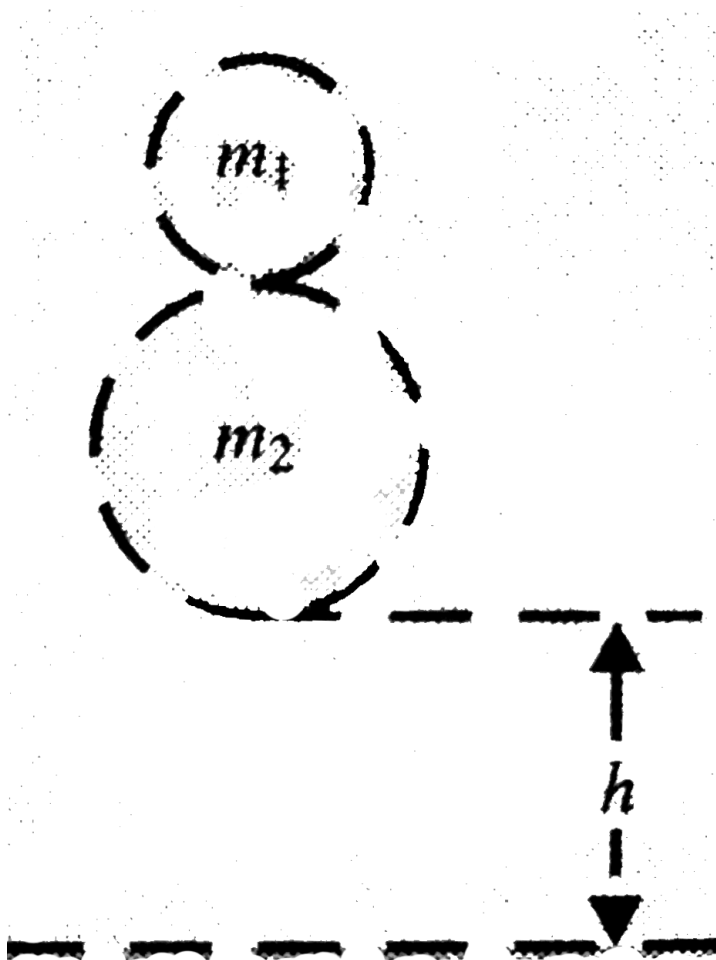



Exercise 1.1

1. Two children A and B of same mass (including their caps) M are sitting on a see-saw as shown in Fig. Initially, the beam is horizontal. At once, child B throws away his cap (mass $\frac{M}{25}$) which falls at point Q , midpoint of the left half of the beam, due to this the balance of beam is disturbed. To balance it again what is the mass in required

to be put at point P on the right half of the beam?
beam?

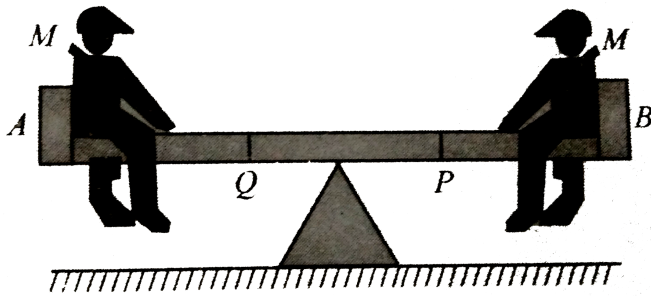

[Watch Video Solution](#)

2. Two blocks A and B each of equal masses m are released from the top of a smooth fixed wedge as shown in the figure. Find the magnitude of the acceleration of the centre of

mass of the two blocks.

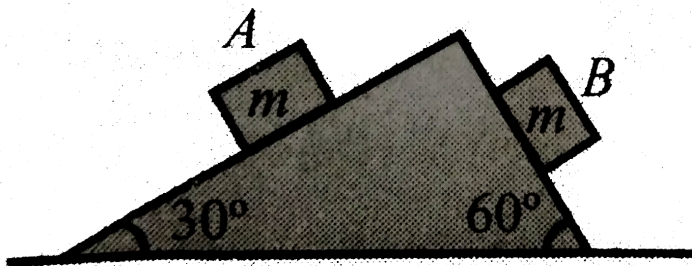

Watch Video Solution

3. Consider a rectangular plate of dimensions $a \times b$. If this plate is considered to be made up of four rectangles of dimensions $\frac{a}{2} \times \frac{b}{2}$ and we now remove one out of four rectangles. Find the position where the centre of mass of

the remaining system will lie?

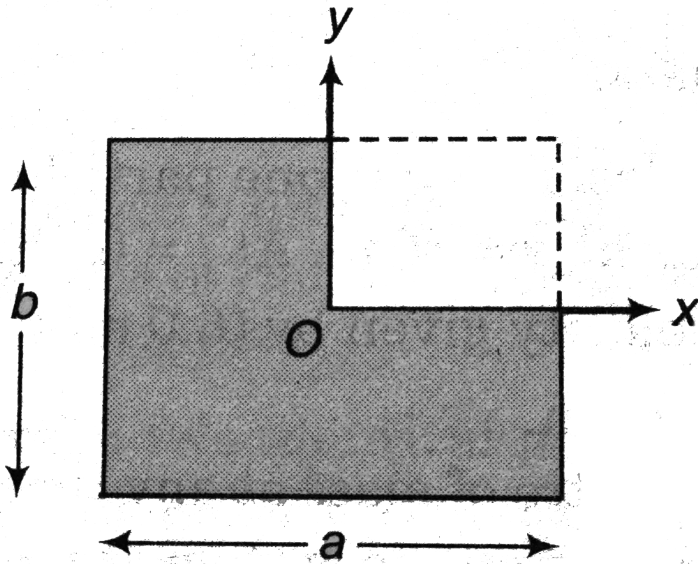

[Watch Video Solution](#)

4. There are two masses m_1 and m_2 placed at a distance l apart. Let the centre of mass of this system is at a point named C. If m_1 is

displaced by l_1 towards C and m_2 is displaced by l_2 away from C. Find the distance, from C where new centre of mass will be located.



[Watch Video Solution](#)

5. Let there are three equal masses situated at the vertices of an equilateral triangle, as shown in Fig. Now particle A starts with a velocity v_1 towards line AB , particle B starts with the velocity v_2 , towards line BC and particle C starts with velocity v_3 towards line

CA. Find the displacement of the centre of mass of the three particles A , B and C after time t . What would it be if $v_1 = v_2 = v_3$?

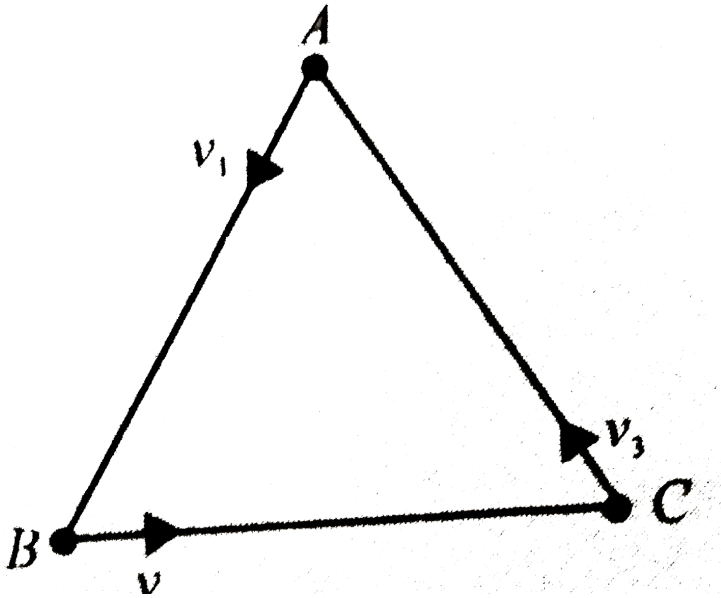

Watch Video Solution

6. Figure shows a flat car of mass M on a frictionless road. A small massless wedge is fitted on it as shown. A small ball of mass m is released from the top of the wedge, it slides over it and falls in the hole at distance l from the initial position of the ball. Find the distance the flat car moves till the ball gets

into the hole.

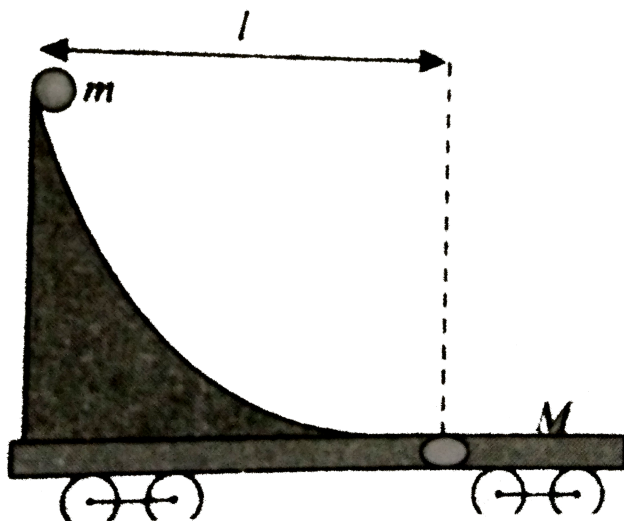

[Watch Video Solution](#)

7. Figure shows two blocks of masses 5kg and 2kg placed on a frictionless surface and connected with a spring. An external kick gives

a velocity of 14 m/s to the heavier block in the direction of lighter one. Deduce (a) velocity gained by the centre of mass and (b) the separate velocities of the two blocks in the centre of mass coordinates just after the kick.

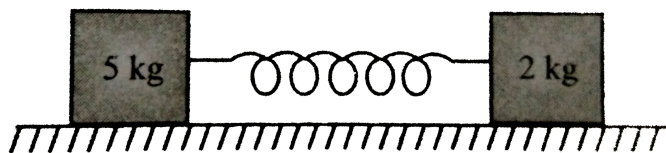

[Watch Video Solution](#)

8. Two blocks of masses m_1 and m_2 , connected by a weightless spring of stiffness k rest on a

smooth horizontal plane as shown in Fig. Block 2 is shifted a small distance x to the left and then released. Find the velocity of centre of mass of the system after block 1 breaks off the wall.

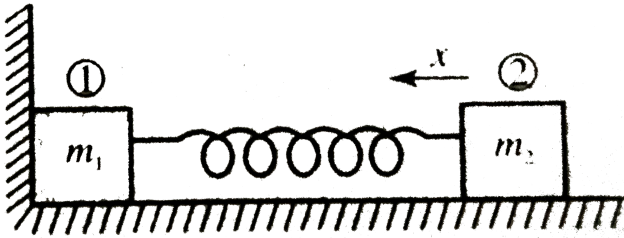

[Watch Video Solution](#)

9. Mr. Verma (50kg) and Mr. Mathur (60kg) are sitting at the two extremes of a 4 m long boat

(40 kg) standing still in water. To discuss a mechanics problem, they come to the middle of the boat. Neglecting friction with water how far does the boat move on the water during the process?



[Watch Video Solution](#)

10. A cart of mass M is at rest on a frictionless horizontal surface and a pendulum bob of mass m hangs from the roof of the cart figure. The string breaks, the bob falls on the floor,

makes several collision on the floor and finally lands up in a small slot made in the floor. The horizontal distance between the string and the slot is L . Find the displacement of the cart during this process

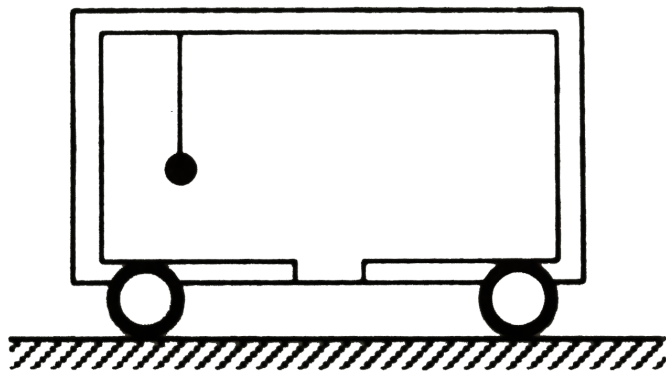

Watch Video Solution

11. Find the displacement of the wedge when m comes out of the wedge. There is no friction anywhere.

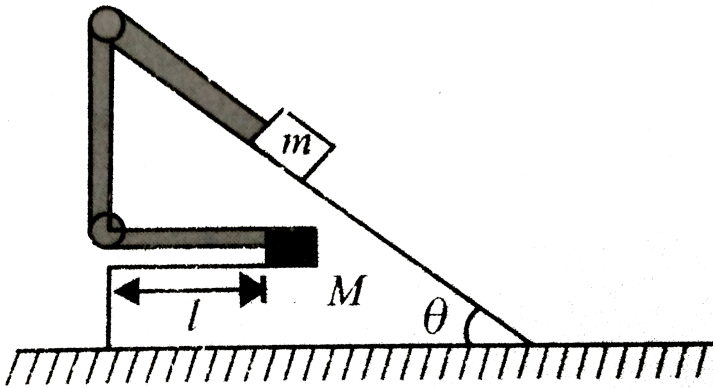

[Watch Video Solution](#)

12. A block of mass m is released from the top of a wedge of mass M as shown in figure. Find

the displacement of wedges on the horizontal ground when the block reaches the bottom of the wedges. Neglect friction everywhere.

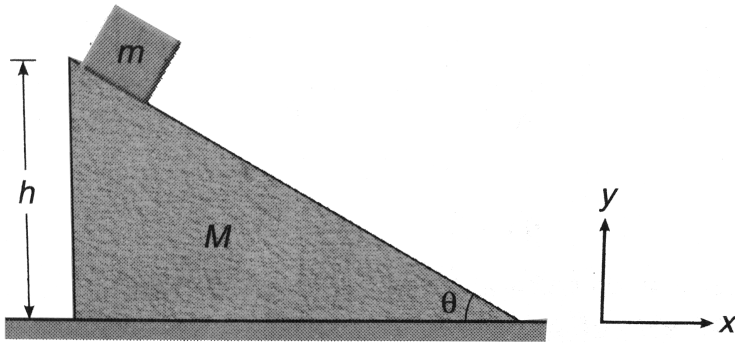

 [Watch Video Solution](#)

13. Calculate the displacement of the wedge when the ball reaches at the bottom of the

groove,

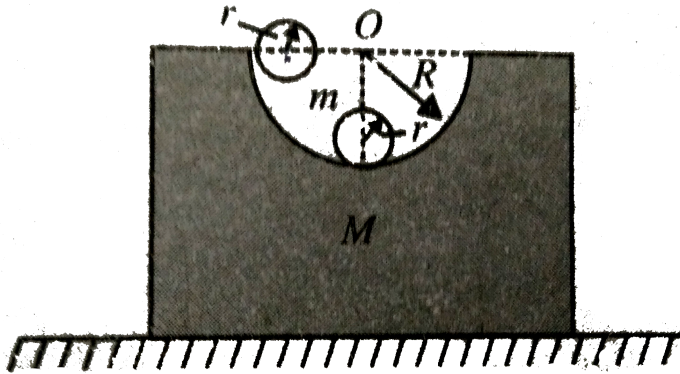

Watch Video Solution

14. A block is released on the convex surface of a hemispherical wedge as shown in Fig. Determine the displacement of the wedge

when the block reaches the angular position θ

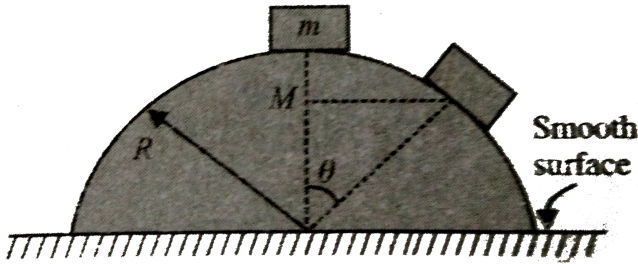

[Watch Video Solution](#)

15. Two masses, m_1 and m_2 , are moving with velocities v_1 and v_2 . Find their total kinetic energy in the reference frame of centre of mass.



[Watch Video Solution](#)

16. Figure shows the system is at rest initially with $x = 0$, A man and a woman both are initially at the extreme carrier of the platform. The man and the woman start to move towards each other. Obtain an expression for the displacement s of the platform when the two meet in terms of the displacement x_1 of

the man relative to the platform. `

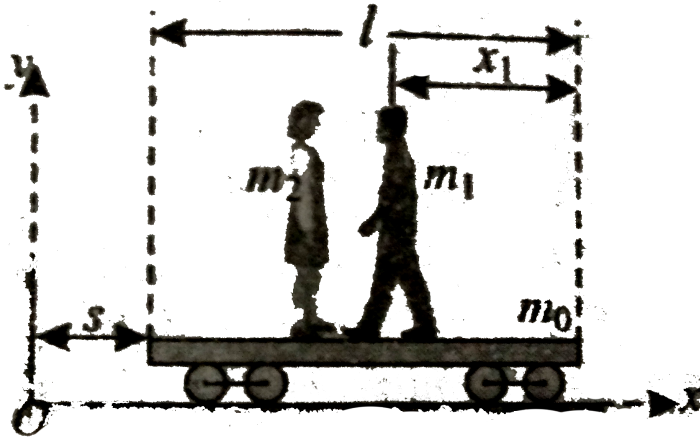

[Watch Video Solution](#)

17. A 30kg projectile moving horizontally with a velocity $\vec{v}_0 = (120\text{m/s})\hat{i}$ explodes into two fragments A and B of masses 12kg and 8kg , respectively. Taking point of explosion as origin

and knowing that $3s$ later position of fragment A is $(300m, 24m, -48m)$, determine the position of fragment B at the instant.



[Watch Video Solution](#)

18. Two $20kg$ cannon balls are chained together and fired horizontally with a velocity of $200m/s$ from the top of a $30m$ wall. The chain breaks during the flight of the cannon balls and one of them strikes the ground at $t = 2s$, at a distance of $250m$ from the foot fo

the wall, and 5 m to the right of line of fire
determine the position of the other cannon
ball at that instant Neglect the resistance of
air.

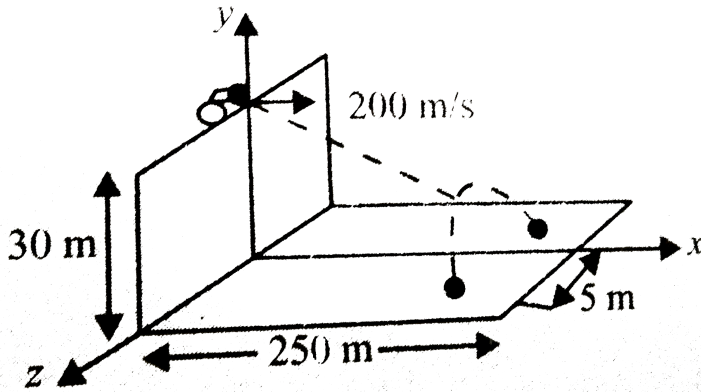

[Watch Video Solution](#)

19. A juggler juggles three balls in a continuous cycle. Any one ball is in contact with his hand for one-fifth of the time. Describe the motion of the centre of mass of the three balls. What average force does the juggler exert on one ball while he is touching it?



Watch Video Solution

20. A cannon and a supply of cannon balls are inside a sealed rail road car. The cannon fires

to the right, the car recoils to the left. The canon balls remain in the car after hitting the far wall. Show that no matter how the cannon balls are fired, the rail road car cannot travel more than L . assuming it starts from rest.

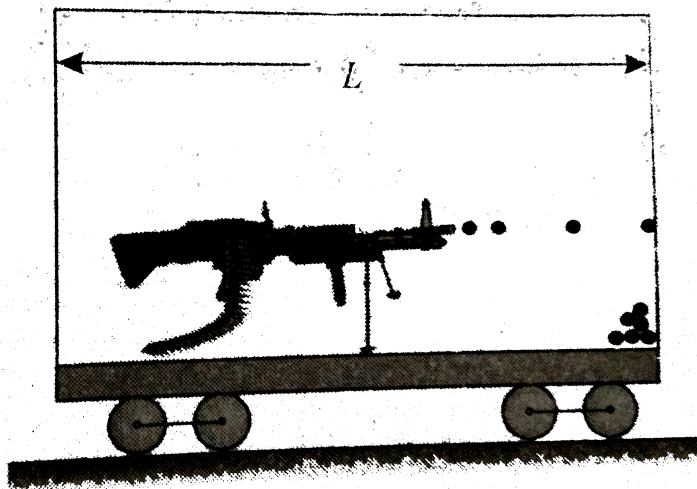

[Watch Video Solution](#)

Exercise 1.2

1. A bomb, initially at rest, explodes into several pieces. (a) Is linear momentum of the system conserved? (b) Is kinetic energy of the system conserved? Explain.



[Watch Video Solution](#)

2. You are standing perfectly still and then you take a step forward. Before the step your momentum was zero, but afterward you have

some momentum. Is the principle of conservation of momentum violated in this case?



[Watch Video Solution](#)

3. Does the centre of mass of a rocket in free space accelerate? Explain. Can the speed of a rocket exceed the exhaust speed of the fuel? Explain.



[Watch Video Solution](#)

4. Discuss the possibility of conservation of linear momentum of a block moving on a rough inclined plane if $\mu = \tan \theta$

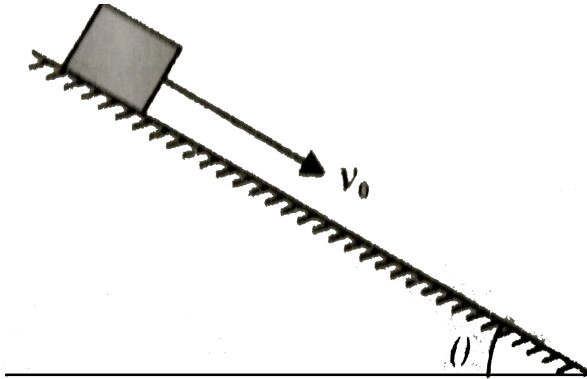

 [Watch Video Solution](#)

5. A shell is fired from a cannon with a speed of 100 m/s at an angle 30° with the vertical (y -

direction). At the highest point of its trajectory, the shell explodes into two fragments of masses in the ratio 1:2. The lighter fragment moves vertically upwards with an initial speed of $200m/s$. What is the speed of the heavier fragment at the time of explosion?



[Watch Video Solution](#)

6. Figure shows a block A of mass $6m$ having a smooth semicircular groove of radius a placed

on a smooth horizontal surface. A block B of mass m is released from a position in groove where its radius is horizontal. Find the speed of the bigger block when the smaller block reaches its bottom most position.

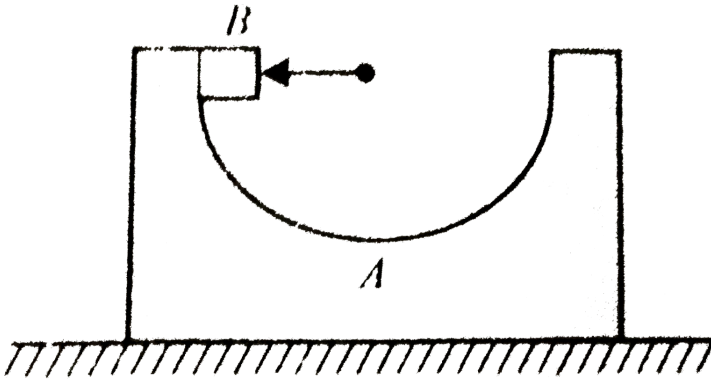

Watch Video Solution

7. Two friends A and B (each weighing 40kg) are sitting on a frictionless platform some distance d apart. A rolls a ball of mass 4kg on the platform towards B which B catches. Then B rolls the ball towards A and A catches it. The ball keeps on moving back and forth between A and B . The ball has a fixed speed of 5m/s on the platform.

a. Find the speed of A after he rolls the ball for the first time.

b. Find the speed of A after he catches the ball for the first time.

- c. Find the speed of A and B after the ball has made five round trips and is held by A .
- d. How many times can A roll the ball?
- e. Where is the centre of mass of the system $A + B +$ ball at the end of the n th trip?



[Watch Video Solution](#)

8. A smooth wedge of mass M rests on a smooth horizontal surface. A block of mass m is projected from its lowermost point with velocity v_0 . What is the maximum height

reached by the block?

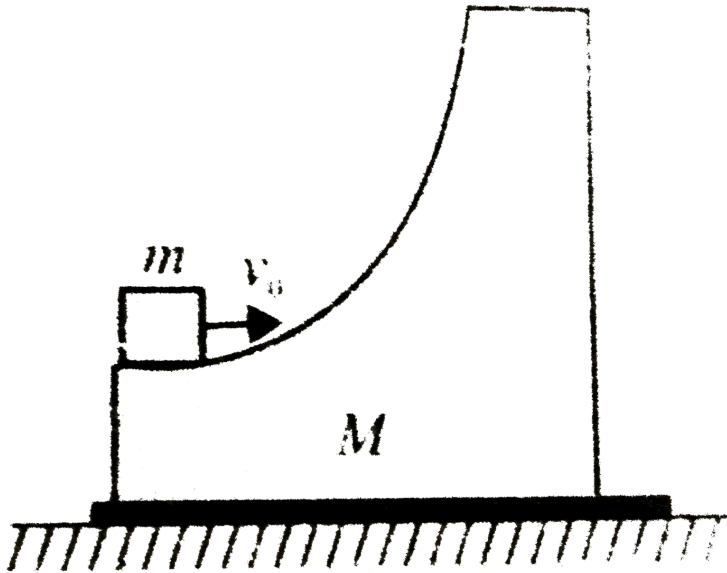

[Watch Video Solution](#)

9. Two identical buggies 1 and 2 with one man in each move along parallel rails. When the

buggies are opposite to each other, the men jump in a direction perpendicular to the direction of motion of buggies, so as to exchange their places. As a consequence, buggy 1 stops and buggy 2 keeps moving in the same direction with its final velocity v . Find the initial velocities v_1 and v_2 of buggies. Mass of each buggy (without man) equals M mass of each man is ignore frictional effects anywhere and the buggies are constrained to

move along the rails only.

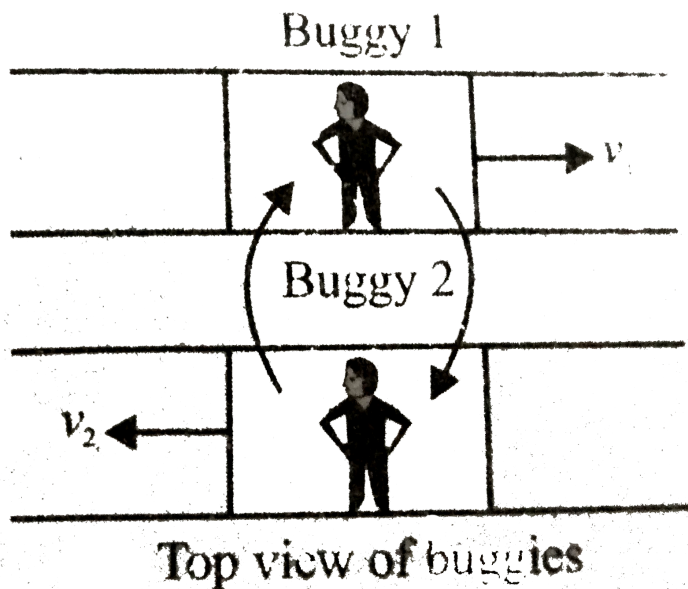

[Watch Video Solution](#)

10. In Fig. a man stands on a boat floating in still water. The mass of the man and the boat is 60kg and 120kg , respectively.

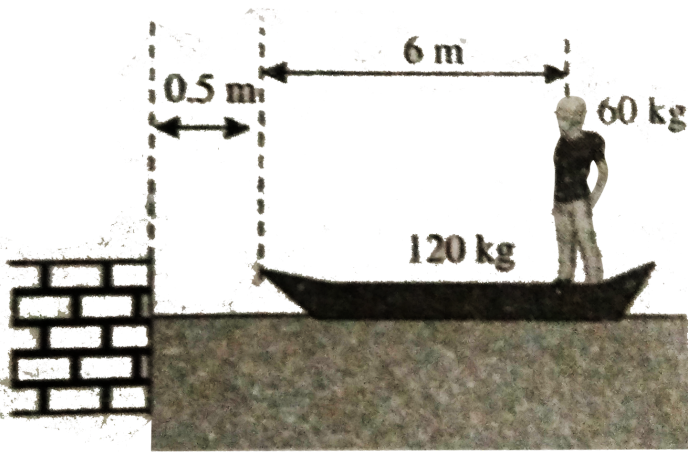

a. If the man walks to the front of the boat and stops. what is the separation between the boat and the pier now?

b. If the man moves at a constant speed of 3 m/s relative to the boat, what is the total kinetic energy of the system (boat + man)?

Compare this energy with the kinetic energy of the system if the boat was tied to the pier.



Watch Video Solution

11. Two blocks of masses $m_1 = 2\text{kg}$ and $m_2 = 5\text{ kg}$ are moving in the same direction along a frictionless surface with speeds 10m/s and 3m/s , respectively, m_2 being ahead of m_1 . An ideal spring with $k = 1120\text{N/m}$ is attached to the back side of m_2 . Find the maximum compression of the spring when the blocks collide. What are the final velocities of the blocks when they

separate?

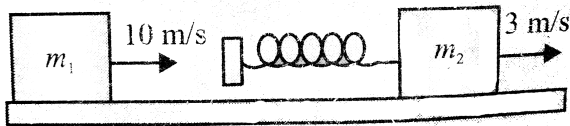

[Watch Video Solution](#)

12. An 80kg boy and his 40kg sister, both wearing roller blades, face each other at rest. The girl pushes the boy hard, sending him backward with velocity 3.0m/s towards the west. Ignore friction, (a) Describe the subsequent motion of the girl. (b) How much chemical energy is converted into mechanical

energy in the girl's muscles? (c) Is the momentum of the boy-girl system conserved in the pushing apart process? How can it be with no motion beforehand and plenty of motion afterward?



Watch Video Solution

13. Two blocks of masses M and $3M$ are placed on a horizontal, frictionless surface. A light spring is attached to one of them and the blocks are pushed together with the spring

between them. A cord initially holding the blocks together is burned, after that, the block of mass $3M$ moves to the right with a speed of $2.00m/s$. (a) What is the velocity of the block of mass M . (b) Find the system's original elastic potential energy, taking $M = 0.350kg$. (c) Is the original energy in the spring or in the cord? Explain your answer. (d) Is momentum of the system conserved in the bursting apart process? How can it be with large forces acting? How can it be with no motion

beforehand and plenty of motion afterward?

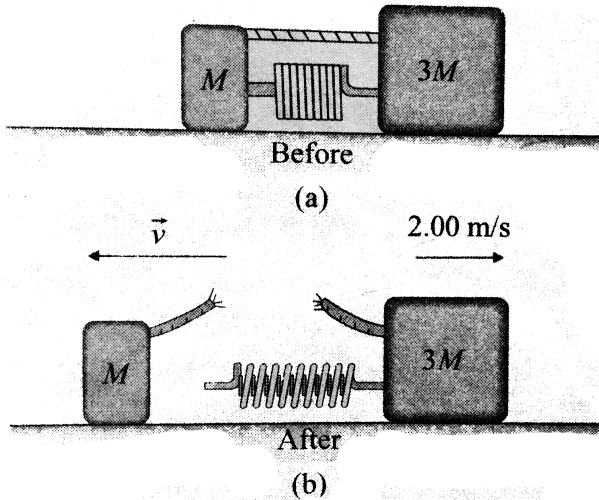

[Watch Video Solution](#)

14. A pendulum bob of mass 10^{-2} kg is raised to a height $5 \times 10^{-2} \text{ m}$ and then released. At the bottom of its swing, it picks up a mass

10^{-3} kg. To what height will the combined mass rise?



Watch Video Solution

15. A rifle man, who together with his rifle has a mass of 100kg , stands on a smooth surface and fires 10 shots horizontally. Each bullet has a mass 10g and a muzzle velocity of 800m/s ,

a. What velocity does the rifle man acquire at the end of 10 shots?

b. If the shots are fired in 10s , what will he the

average force exerted on him?

c. Compare his kinetic energy with that of 10 bullets



[Watch Video Solution](#)

16. A projectile of mass 50kg is shot vertically upwards with an initial velocity of 100m/s . After 5s , it explodes into two fragments, one of which having a mass of 20kg travels vertically up with a velocity of 150m/s :

a. What is the velocity of the other fragment

that instant?

b. Calculate the sum of momenta of fragment 3s after the explosion. What would have been the momentum of the projectile at this instant if there had been no explosion?



[Watch Video Solution](#)

17. a. A rail road flat car of mass M can roll without friction along a straight horizontal track. Initially, a man of mass m is standing on the car which is moving to the right with

speed v_0 . What is the change in velocity of the car if the man runs to the left so that his speed relative to the car is v_{rel} just before he jumps off at the left end?

b. If there are n men each of mass m on the car, should they all run and jump off together or should they run and jump one by one in order to give a greater velocity to the car?

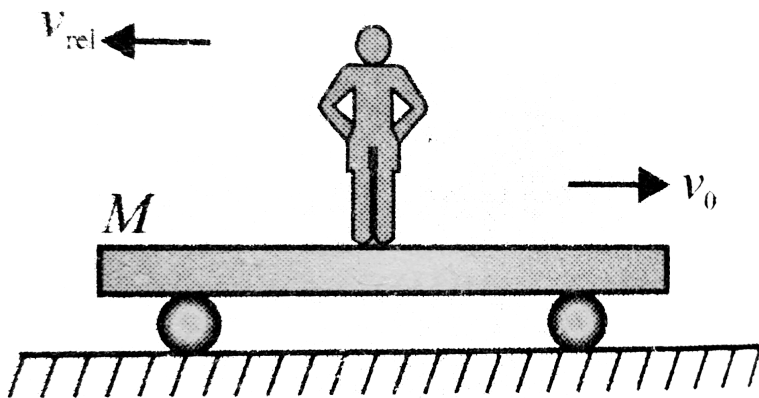

Watch Video Solution

18. a. A rail road car of mass M is moving without friction on a straight horizontal track with a velocity ct . A man of mass m lands on it normally from a helicopter. What will be the new velocity of the car? Itbgt b. If now the man begins to run on it with speed um with respect to car in a direction opposite to motion of the car, what will be the new velocity of the car?



Watch Video Solution

19. A shell of mass 2kg moving at a rate of 4m/s suddenly explodes into two equal fragments. The fragments go in directions inclined with the original line of motion with equal velocities, If the explosion imparts 48J of translational kinetic energy to the fragments, find the velocity and direction of each fragment.



Watch Video Solution

20. A mud ball at rest explodes into three fragments of masses in the ratio 1:2:1. The two equal masses move with velocities $2\hat{i} + 5\hat{j} - 6\hat{k}$ and $-4\hat{i} + 3\hat{j} + 2\hat{k}$. Find the velocity of the third mass.

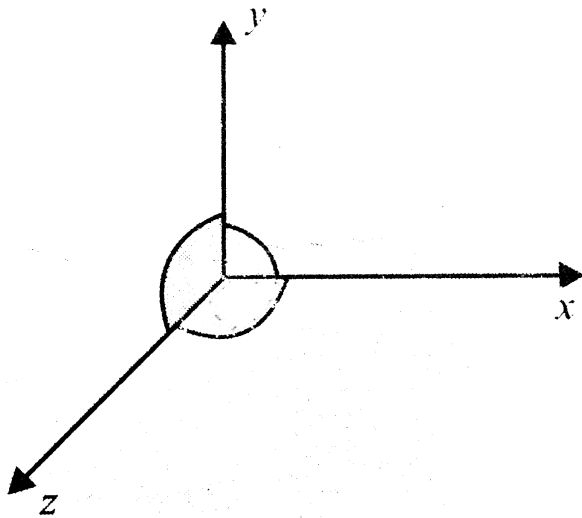

Watch Video Solution

21. A hemisphere of radius R and mass $4m$ is free to slide with its base on a smooth horizontal table. A particle of mass m is placed on the top of the hemisphere. The angular velocity of the particle relative to centre of hemisphere at an angular displacement θ when velocity of hemisphere has become v is



[Watch Video Solution](#)

22. A gun (mass= M) fires a bullet (mass= m) with speed v_r relative to barrel of the gun which is

inclined at an angle of 60° with horizontal.

The gun is placed over a smooth horizontal surface. Find the recoil speed of gun.



[Watch Video Solution](#)

23. Two trolleys A and B are free to move on a level frictionless track, and are initially stationary. A man on trolley A throws a bag of mass 10kg with a horizontal velocity of 4m s^{-1} with respect to himself on to trolley B of mass 100kg . The combined mass of trolley A

(excluding bag) and the man is 140km . Find the ratio of velocities of trolleys A and B , just after the bag lands on trolley B .



[Watch Video Solution](#)

Exercise 1.3

1. A ball is dropped on a floor from a height h . If the coefficient of restitution is e , find the height to which the ball will rise after touching

the floor and the time it will take to come to rest again.



[Watch Video Solution](#)

2. An elevator platform is going up at a speed of 20m/s and during its upward motion a small ball of 50g mass, falling in downward direction, strikes the platform at speed 5m/s . Find the speed with which the ball rebounds.



[Watch Video Solution](#)

3. A ball of mass m is distributed from the top of a fixed smooth circular tube in a vertical plane and falls impinging on a ball of mass $2m$ at the bottom. The coefficient of restitution is $\frac{1}{2}$. Find the heights to which the balls rise after a second impact.



[Watch Video Solution](#)

4. A particle of mass $1kg$ is attached to a string of length $5m$. The string is attached to a fixed point O . It is released from the position as

shown in Fig. Calculate

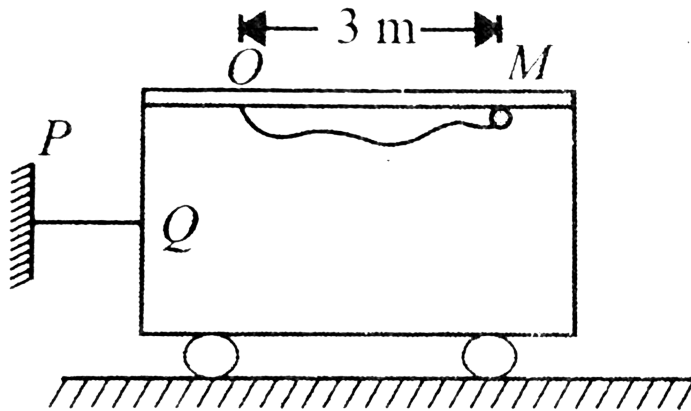

- the impulse developed in the string when it becomes taut,
- the velocity of the particle just after the string becomes taut,
- the impulse developed in this string PQ at this instant.



Watch Video Solution

5. A heavy ball of mass $2M$ moving with a velocity v_0 collides elastically head on with a cradle of three identical ball each of mass M as shown in figure. Determine the velocity of each ball after collision.

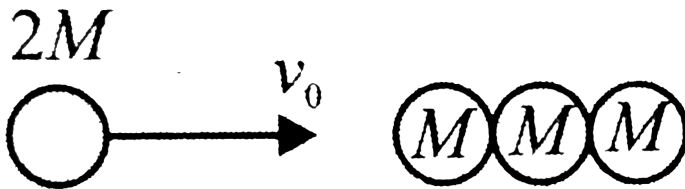

[Watch Video Solution](#)

6. In Fig. there are n identical spheres suspended with wires of equal length. The spheres are almost in contact with each other. Sphere 1 is pulled aside and released. If sphere 1 strikes sphere 2 with velocity u . find an expression for velocity v_n of the n th sphere immediately after being struck by the one adjacent to it. The coefficient

of restitution for all the impacts is e .

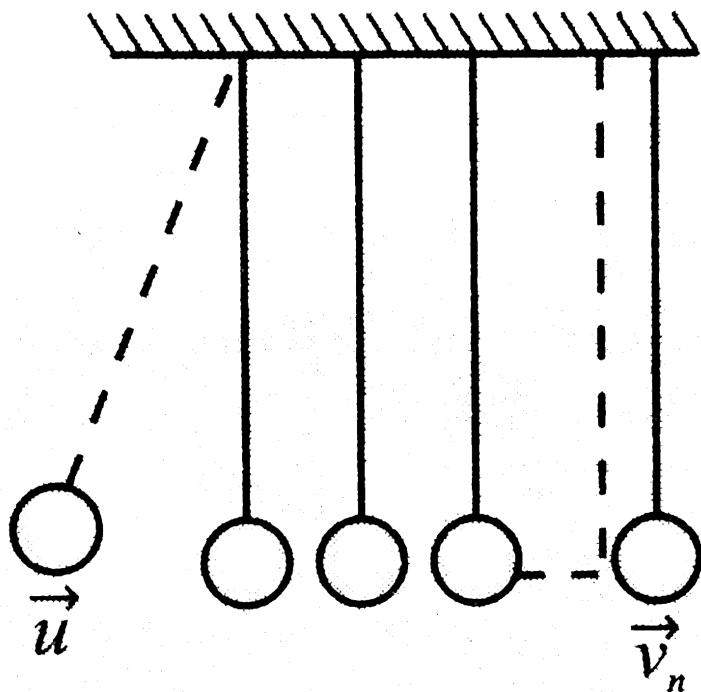

[Watch Video Solution](#)

7. A smooth sphere of mass m is moving on a horizontal plane with a velocity $3\hat{i} + \hat{j}$ when it

collides with a vertical wall which is parallel to the \hat{j} vector. If the coefficient of restitution between the sphere and the wall is $1/2$. find

- a. the velocity of the sphere after impact,
- b. the loss in kinetic energy caused by the impact.
- c. the impulse that acts on the sphere.



[Watch Video Solution](#)

8. Two smooth spheres. A and B . having equal radii, lie on a horizontal table. A is of mass m

and B is of mass $3m$. The spheres are projected towards each other with velocity vector $5\hat{i} + 2\hat{j}$ and $2\hat{i} - \hat{j}$, respectively, and when they collide the line joining their centres is parallel to the vector \hat{i} . If the coefficient of restitution between A and B is $1/3$, find the velocities after impact and the loss in kinetic energy caused by the collision. Find also the magnitude of the impulses that act at the instant of impact.



Watch Video Solution

9. A block m_1 strikes a stationary block m_3 inelastically. Another block m_2 is kept on m_3 . Neglecting the friction between all contacting surfaces, calculate the fractional decrease in KE of the system in collision.



Watch Video Solution

10. A mass m_1 moves with a great velocity. It strikes another mass m_2 at rest in head-on collision. It comes back along its path with low

speed after collision. Then find out whether

$m_1 < m_2$ or $m_1 > m_2$.



Watch Video Solution

11. A ball of mass $4kg$ moving with a velocity of $12m/s$ impinges directly on another ball of mass $8kg$ moving with velocity of $4m/s$ in the same direction. Find their velocities after impact and calculate the loss of KE due to impact if $e = 0.5$.



Watch Video Solution

12. A bullet of mass $2g$ travelling at a speed of $500m/s$ is fired into a ballistic pendulum of mass $1.0kg$ suspended from a cord $1.0m$ long. The bullet penetrates the pendulum and emerges with a velocity of $100m/s$. Through what vertical height will the pendulum rise?



Watch Video Solution

13. A $3.00kg$ steel ball strikes the wall with a speed of $10.0m/s$ at an angle of 60° with the

surface. It bounces off with the same speed and angle. If the ball is in contact with the wall for 0.200s , what is the average force exerted by the wall on the ball?



[Watch Video Solution](#)

14. Two identical balls are approaching towards each other on a straight line with velocity 2m/s and 4m/s , respectively. Find the final velocities after elastic collision between

them.

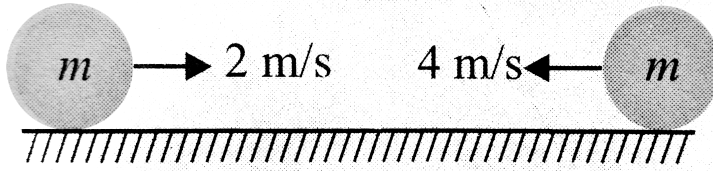

[Watch Video Solution](#)

15. Three balls of masses m_1 , m_2 and m_3 are lying in a straight line. The first ball is moved with a certain velocity so that it strikes the second ball directly and itself comes to rest. The second ball collides with the third and is itself reduced to rest. If e is the coefficient of

restitution for each ball, write down the relation of m_3 in terms of m_1 and m_2 .



Watch Video Solution

16. Two identical balls A and B lie on a smooth horizontal surface, which gradually merges into a curve to a height $3.2m$. Ball A is given a velocity of $10m/s$, to collide head-on with ball B , which then takes up the curved path. What is the minimum coefficient of restitution, e , for the collision between A and B in order that

ball B reaches the highest point C of the curve.

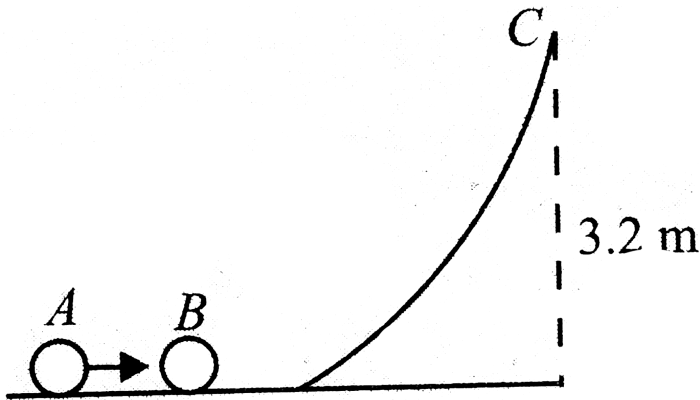

[Watch Video Solution](#)

17. A smooth ball of mass m is suspended from a light string of length $1m$. Another ball of mass $2m$ strikes the ball of mass m in

horizontally with a speed of $u = \sqrt{35}m/s$.

The coefficient of restitution for the collision is

e . The string becomes loose, when it makes an

angle of 30° with the horizontal, find the value

of e .

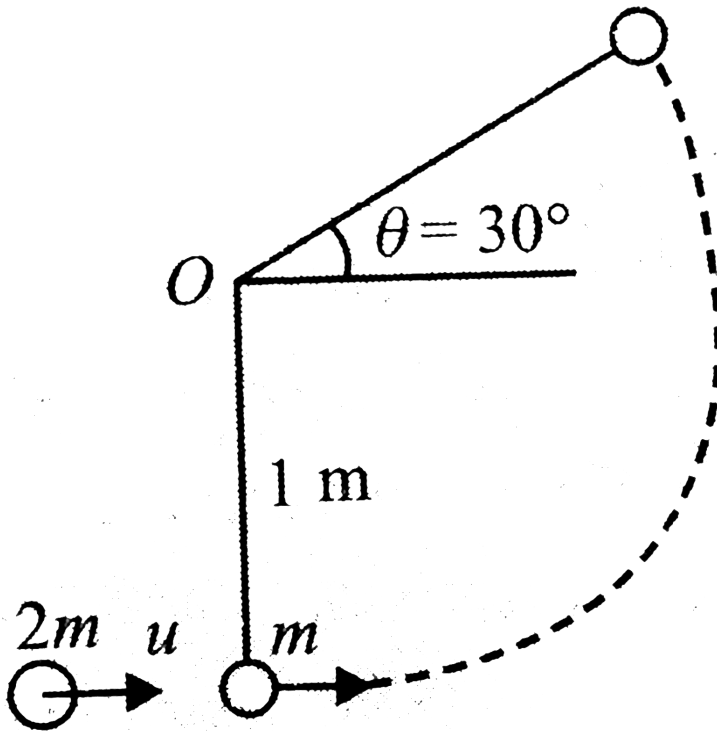

Watch Video Solution

18. Three particles A , B and C of respective masses m_1 , m_2 and m_3 lie on a smooth horizontal surface, and are fastened to two light inextensible strings as shown in Fig. The particle A is imparted an impulse J along \overrightarrow{BA} . Find the initial speed of each particle.

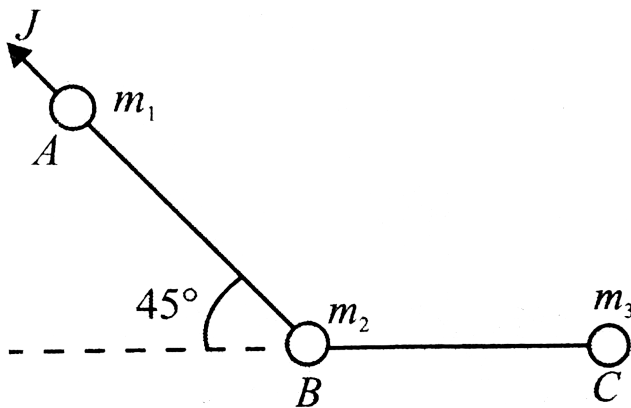

Watch Video Solution

19. A ball moving along a straight line collides elastically with another stationary ball of the same mass. At the moment of collision, the angle between the straight line passing through the centres of the balls and the direction of its initial motion of the striking ball is θ , find the fraction of the kinetic energy of the striking ball converted into potential energy at the moment of the maximum

deformation.

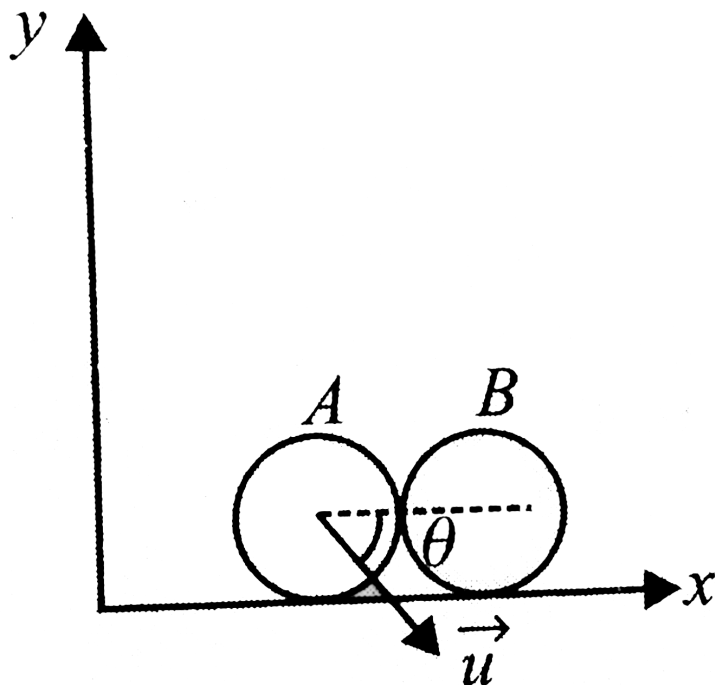

 [Watch Video Solution](#)

20. A machine gun fires a bullet of mass 40 g with a velocity 1200ms^{-1} . The man holding it,

can exert a maximum force of $144N$ on the gun. How many bullets can be fired per second at the most?



[Watch Video Solution](#)

21. A plate of mass M is held at rest by firing bullets from below. Each bullet has a mass m , velocity u (up) just before hitting and stops after hitting the plate for a moment and falls. Determine the number of bullets striking the

plate Fig. per unit time

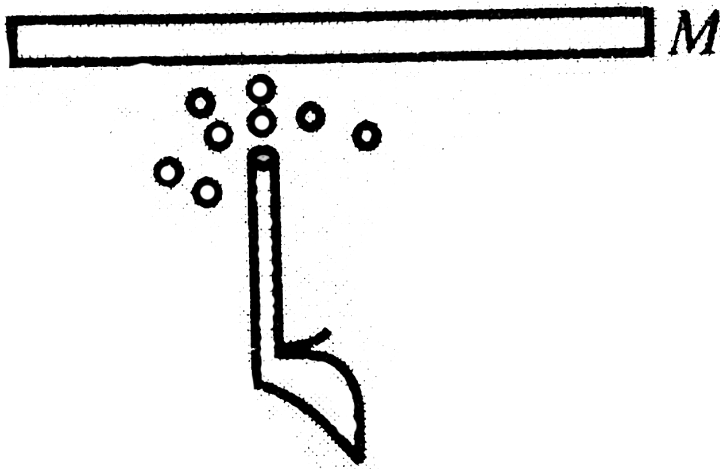

[Watch Video Solution](#)

22. A steel ball is suspended by a light inextensible string of length l from a fixed point O . When the ball is in equilibrium it just touches a vertical wall as shown in the figure.

The ball is first taken aside such that string becomes horizontal and then released from rest. If coefficient of restitution is e , then find the maximum deflection of the string after n th collision.

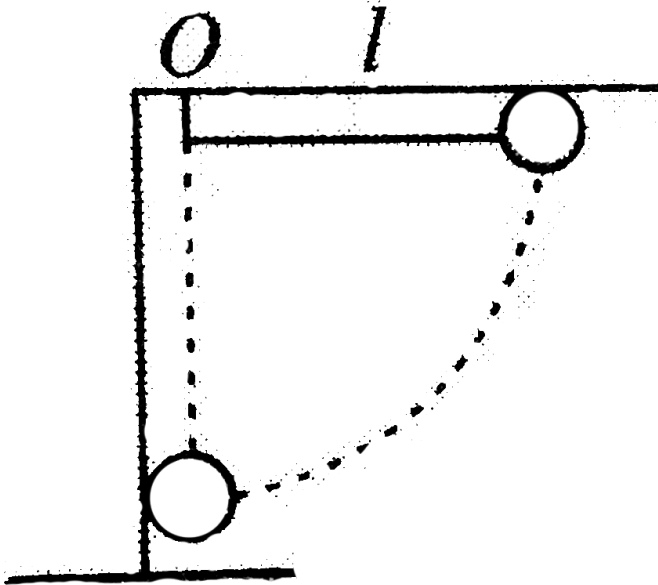

[Watch Video Solution](#)

23. A smooth ball is released from rest from a height h as shown in figure. It slides down the first inclined plane and collides with the second inclined plane.

a. If $e = 0$, find the speed of the ball just after leaving the inclined plane 1.

b. If the particle moves horizontally just after

the collision find e .

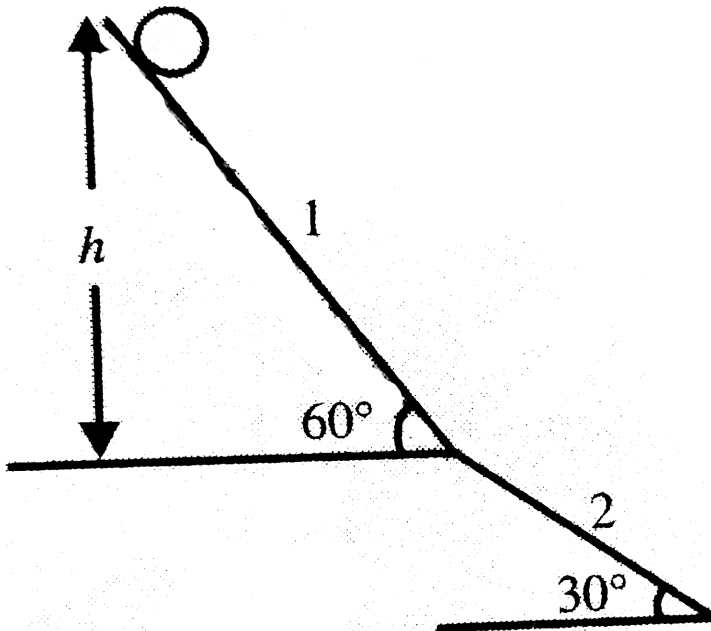

[Watch Video Solution](#)

24. A small particle of mass m is released from a height h on a large smooth sphere kept on a

perfectly smooth surface as shown in the figure. Collision between particle and sphere is perfectly inelastic. Determine the velocities of particle and sphere after collision.

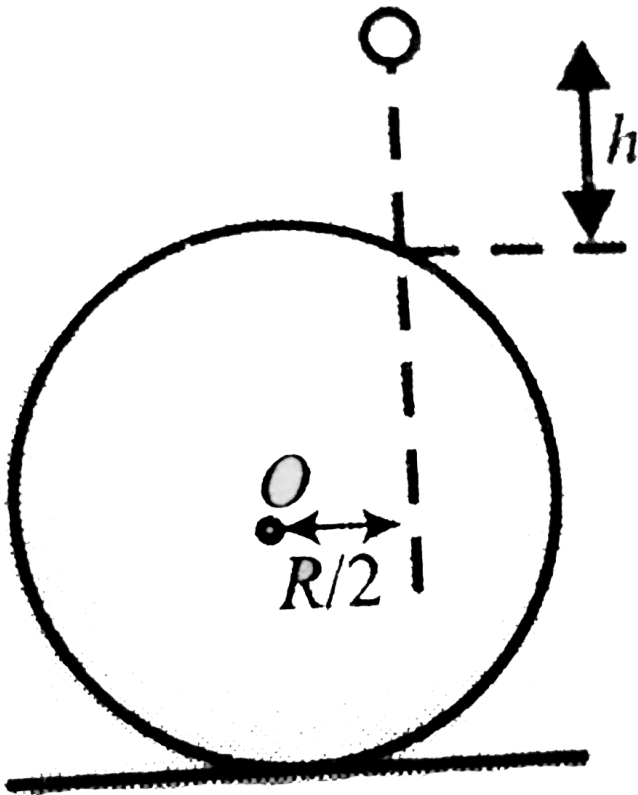

Watch Video Solution

Subjective

1. Two identical smooth balls are projected from points O and A on the horizontal ground with same speed of projection. The angle of projection in each case is 30° . The distance between O and A is $100m$. The balls collide in mid-air and return to their respective points of projection. If the coefficient of restitution is 0.7 , find the speed of projection of either ball

(in m/s) correct to nearest integer. (Take

$g = 10ms^{-2}$ and $\sqrt{3} = 1.7$)

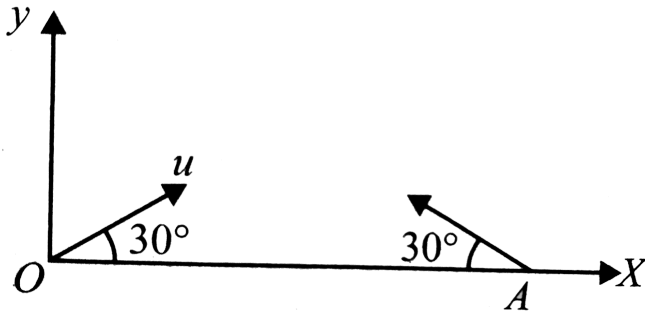

[Watch Video Solution](#)

2. A stationary light, smooth pulley can rotate without friction about a fixed horizontal axis. A light rope passes over the pulley. One end of the rope supports a ladder with man and the

other end supports a counterweight of mass M . Mass of the man is m . initially, the centre of mass of the counterweight is at a height h from that of man as shown in Fig.

If the man starts to climb up the ladder slowly, calculate work done by him to reach his centre of mass in level with that of the

counterweight.

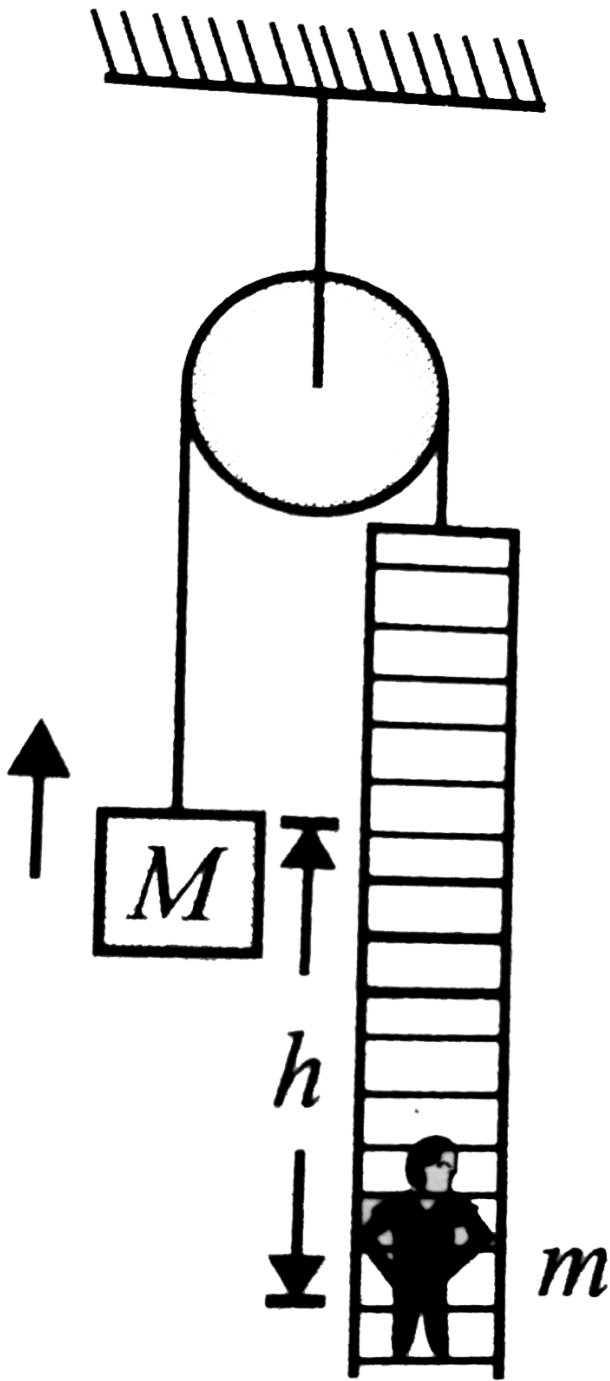



Watch Video Solution

3. Two blocks A and B are joined by means of a slacked string passing over a massless pulley as shown in Figure. The system is released from rest and it becomes taut when B falls a distance $0.5m$.

a. Find the common velocity of the two blocks just after the string becomes taut.

b. Find the magnitude of impulse on the pulley by the clamp during the small interval while

string becomes taut.

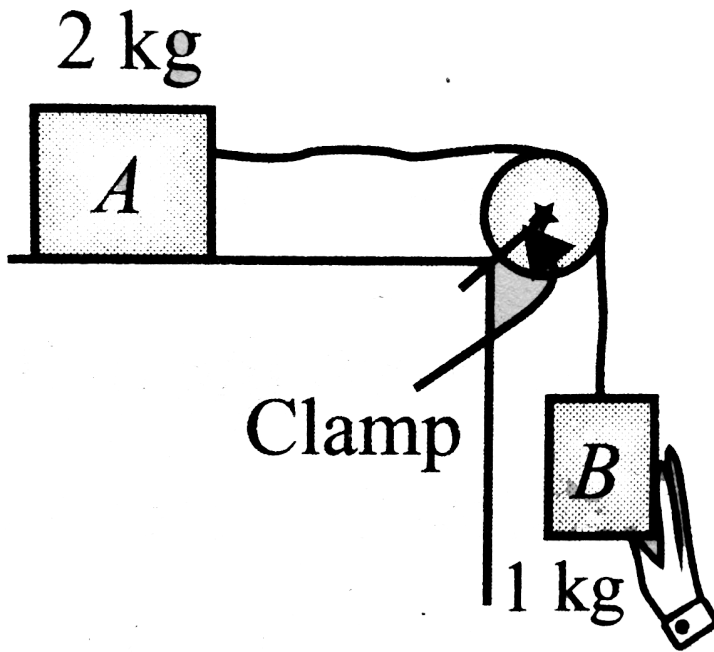

[Watch Video Solution](#)

4. Two blocks A and B of masses m and $2m$, respectively are connected by a spring of force

constant k . The masses are moving to the right with uniform velocity v each, the heavier mass leading the lighter one. The spring is in the natural length during this motion. Block B collides head on with a third block C of mass m , at rest, the collision being completely inelastic. Calculate the maximum compression of the spring.

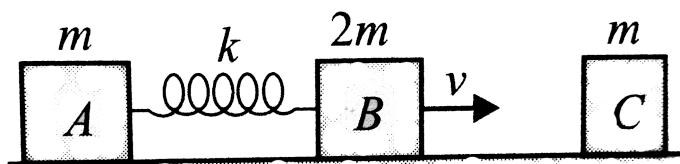

[Watch Video Solution](#)

5. Two small spheres A and B of equal radius but different masses of $3m$ and $2m$ are moving towards each other and impinge directly. The speeds of A and B before collision are, respectively, $4u$ and u . The collision is such that B experiences an impulse of magnitude $6mcu$, where c is a constant.

Determine

- the coefficient of restitution,
- the limits for the value of c for which such collision is possible.



[Watch Video Solution](#)

6. Four railroad cars, each of mass 2.50×10^4 kg, are coupled together and coasting along horizontal tracks at speed v_I towards the south. A very strong movie actor, riding on the second car, uncouples the front car and gives it a big push, increasing its speed to 4.00 m/s southward. The remaining three cars continue moving south, now at 2.00 m/s . (a) Find the initial speed of the cars. (b) How much work did the actor do?



Watch Video Solution

7. A particle of mass m is made to move with uniform speed v along the perimeter of a regular polygon of $2n$ sides. The magnitude of impulse applied at each corner of the polygon is



[Watch Video Solution](#)

8. A smooth ball of mass 1kg is projected with velocity 7m/s horizontal from a tower of height 3.5m . It collides elastically with a wedge

of mass 3 kg and inclination of 45° kept on ground. The ball collides with the wedge at a height of 1 m above the ground. Find the velocity of the wedge and the ball after collision. (Neglect friction at any contact.)

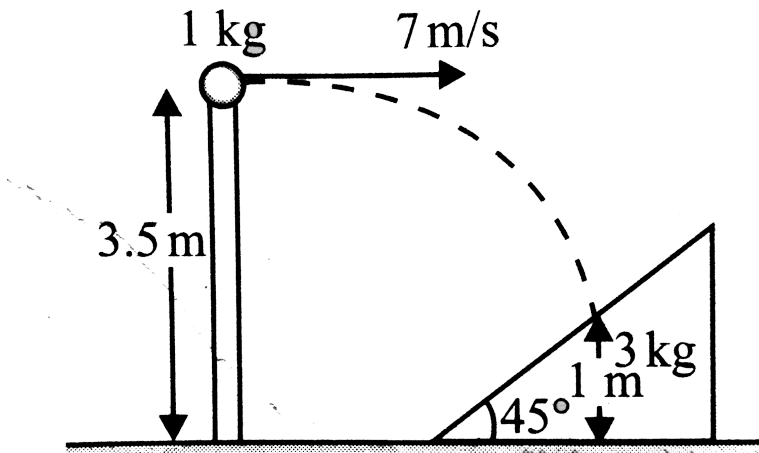

[Watch Video Solution](#)

9. A small ball is projected from point P towards a vertical wall as shown in Fig. It hits the wall when its velocity is horizontal. Ball reaches point P after one bounce on the floor. The coefficient of restitution assuming it to be same for two collisions is $n/2$. All surfaces are

smooth. Find the value of n .

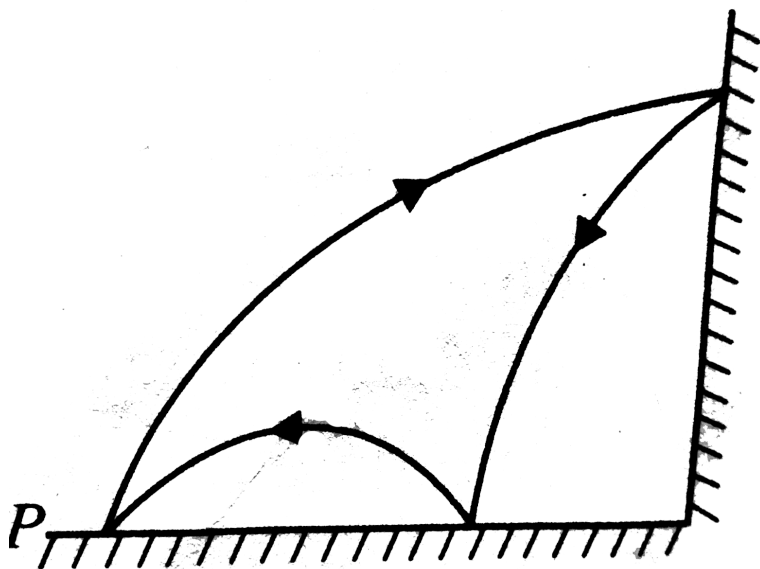

Watch Video Solution

10. A small steel ball A is suspended by an inextensible thread of length $l = 1.5m$ from O . Another identical ball is thrown vertically

downwards such that its surface remains just in contact with thread during downward motion and collides elastically with the suspended ball. If the suspended ball just completes vertical circle after collision, calculate the velocity (in cm/s) of the falling ball just before collision ($g = 10ms^{-2}$).

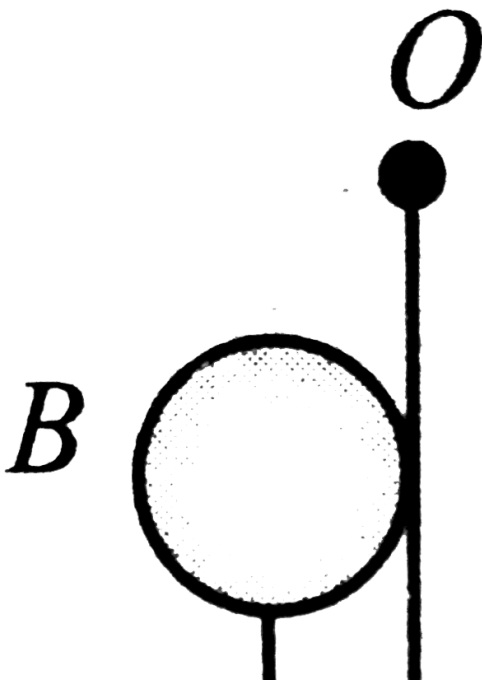

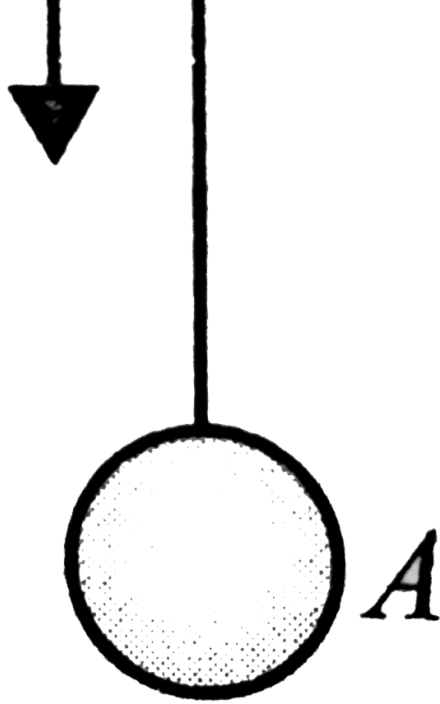

Watch Video Solution

11. A tennis ball with (small) mass m_2 rests on the top of a basketball of mass m_1 which is at a

height h above the ground, and the bottom of the tennis ball is at height $h + d$ above the ground. The balls are dropped. To what height does the tennis ball bounce with respect to ground? (Assume all collisions to be elastic

and $m_1 > m_2$)

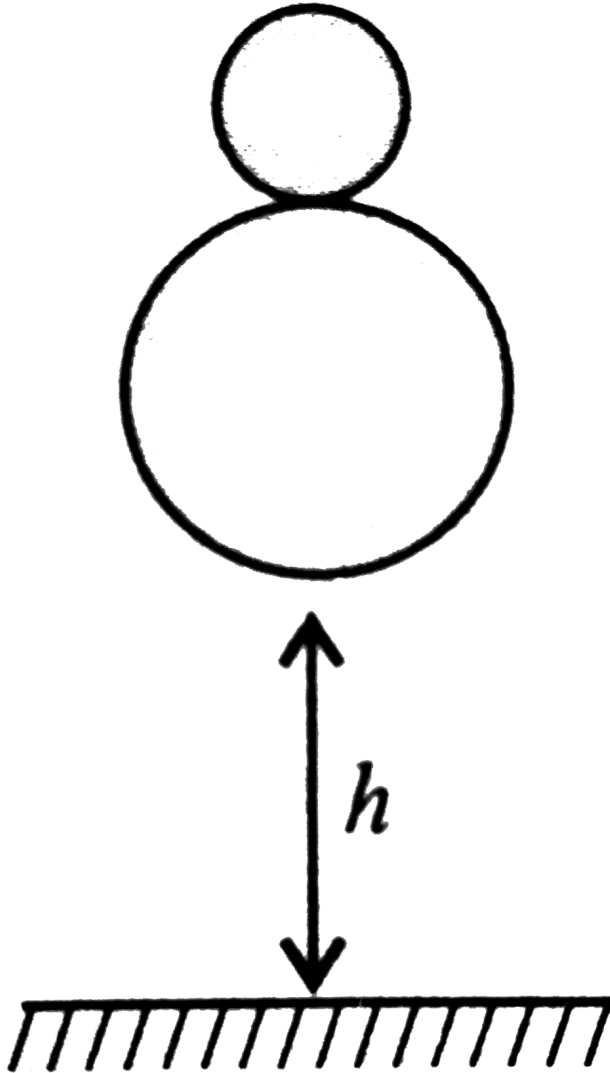

Watch Video Solution

12. A ball of mass m hits a wedge of mass M vertically with speed u , which is placed, on a smooth horizontal surface. Find the maximum compression in the spring, if the collision is perfectly elastic and no friction any where. Spring constant of spring is K .

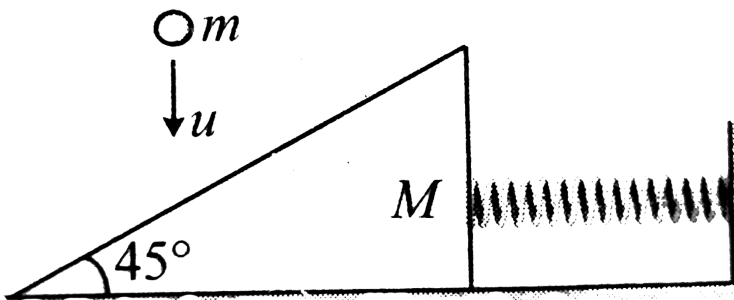

[Watch Video Solution](#)

13. A ball of mass m moving with constant horizontal velocity u strikes a stationary wedge of mass M on its inclined surface as shown in the figure. After collision, the ball starts moving up the inclined plane. The wedge is placed on frictionless horizontal surface.

a. Calculate the velocity of wedge immediately after collision.

b. Calculate the maximum height the ball can

ascend on the wedge.

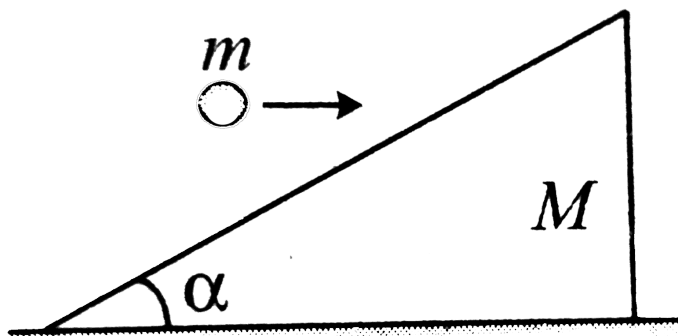

[Watch Video Solution](#)

14. A ball of mass m collides with a stationary wedge of mass M , perpendicular to its inclined face, inclined at an angle as shown in the figure. If the coefficient of restitution between the wedge and ball is e , calculate the

ratio of modulus of velocity of the ball immediately after and before collision. Also calculate the velocity of wedge just after collision.

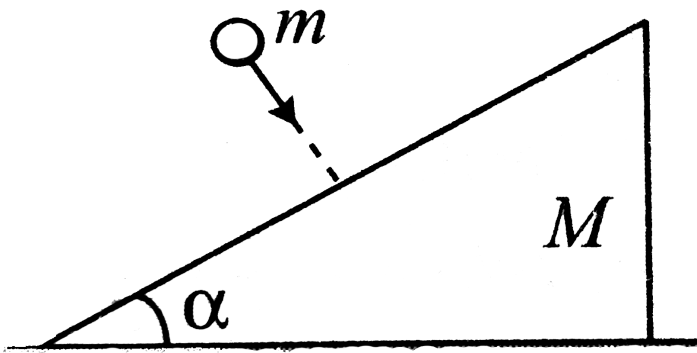

[Watch Video Solution](#)

15. A small bucket of mass M is attached to a long inextensible cord of length L . The bucket is released from rest when the cord is in a horizontal position. In its lowest position the bucket scoops up m of water, what is the height of the swing above the lowest position?



Watch Video Solution

16. Two wooden plank of mass $M_1 = 1kg$, $M_2 = 2.98kg$ smooth surface. A bullet of mass $m = 20gm$ strikes the block M_1

and pierces through it, then strikes the plank B and sticks to it. Consequently both the planks move with equal velocities. Find the percentage change in speed of the bullet when it escapes from the first block.



[Watch Video Solution](#)

17. In the diagram shown, no friction at any contact surface. Initially, the spring has no deformation. What will be the maximum deformation in the spring ? Consider all the

strings to be sufficiently large. Consider the spring constant to be K .

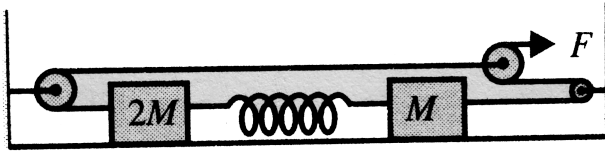

[Watch Video Solution](#)

18. Two blocks A and B of mass m and $2m$ respectively are moving towards a massive (mass $\gg 2m$) cliff with velocities $2v$ and v respectively. The cliff moves with a velocity v . If the coefficient of restitution of collision at the

surface of the cliff is $e = 1/2$, find the:

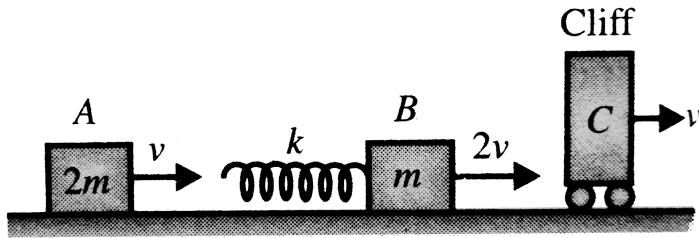

- velocity of the block B just after colliding with the cliff.
- work done by the cliff during collision.
- maximum compression of the spring of stiffness k which is fitted with the block B .

 [Watch Video Solution](#)

19. A boy throws a ball with initial speed \sqrt{ag} at an angle θ to the horizontal. It strikes a smooth vertical wall and returns to his hand. Show that if the boy is standing at a distance 'a' from the wall, the coefficient of restitution between the ball and the wall equals $\frac{1}{(4 \sin 2\theta - 1)}$. Also show that θ cannot be less than 15° .



Watch Video Solution

20. A ball falls freely from a height onto and smooth inclined plane forming an angle α with the horizontal. Find the ratio of the distance between the points at which the jumping ball strikes the inclined plane. Assume the impacts to be elastic.



Watch Video Solution

21. A ball is projected from a point A on a smooth inclined plane which makes an angle α to the horizontal. The velocity of projection

makes an angle θ with the plane upwards. If on the second bounce the ball is moving perpendicular to the plane, find e in terms of α and θ . Here e is the coefficient of restitution between the ball and the plane.



[Watch Video Solution](#)

22. A small ball of mass m is connected by an inextensible massless string of length with an another ball of mass $M = 4m$. They are released with zero tension in the string from a

height h as shown in the figure. Find the time when the string becomes taut for the first time after the mass M collides with the ground. Take all collisions to be elastic.

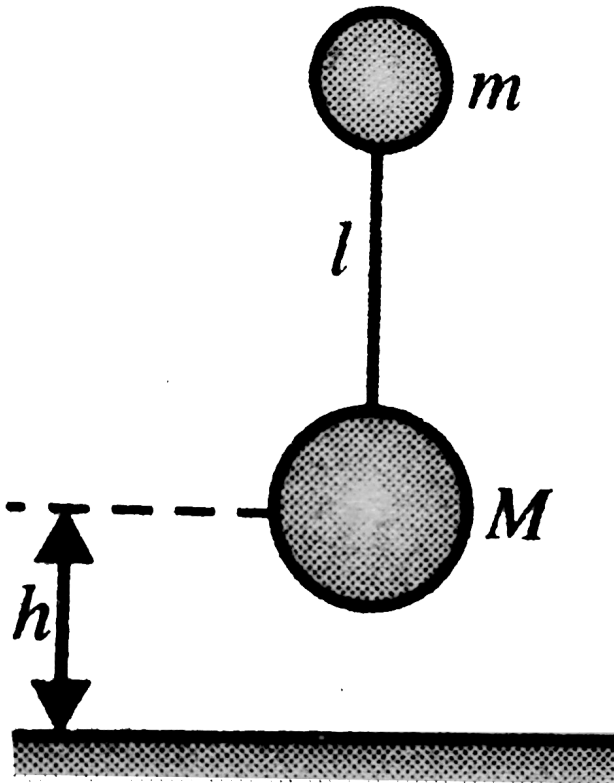

 [Watch Video Solution](#)

23. Two balls A and B each of mass m are placed on a smooth ground as shown in the figure. Another ball C of mass M arranged to the right of ball B as shown. If a velocity v_1 is given to ball A in rightward direction, consider two cases. Case-I $M > m$ and case-II $M < m$. Take all the collisions perfectly elastic ($e = 1$), find the number of collision in case-I and case-II.

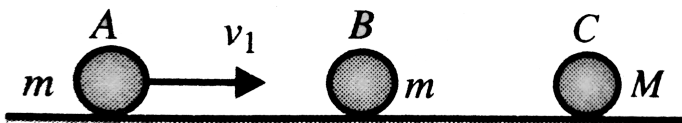



Watch Video Solution

Single Correct

1. An object initially at rest explodes into three equal fragments A , B and C . The momentum of A is $p\hat{i}$ and that of B is $\sqrt{3}p\hat{j}$

where p is a +ve number. The momentum of C will be

A. $(1 + \sqrt{3})p$ in a direction making angle

120° clockwise with that of A

- B. $(1 + \sqrt{3})p$ in a direction making angle 150° anticlockwise with that of B
- C. $2p$ in a direction making angle 150° with that A
- D. $2p$ in a direction making angle 150° with that of B .

Answer: D



Watch Video Solution

2. A ball collides impinges directly on a similar ball at rest. The first ball is brought to rest after the impact. If half of the kinetic energy is lost by impact, the value of coefficient of restitution (e) is

A. $\frac{1}{2}$

B. $\frac{1}{\sqrt{3}}$

C. $\frac{1}{\sqrt{2}}$

D. $\frac{\sqrt{3}}{2}$

Answer: A



Watch Video Solution

3. A 20g bullet pierces through a plate of mass $M_1 = 1kg$ and then comes to rest inside a second plate of mass $M_2 = 2.98kg$ as shown in Fig. It is found that the two plates, initially at rest, now move with equal velocities. Find the percentage loss in the initial velocity of the bullet when it is between M_1 and M_2 . Neglect any loss of material of the plates due to the

action of bullet.

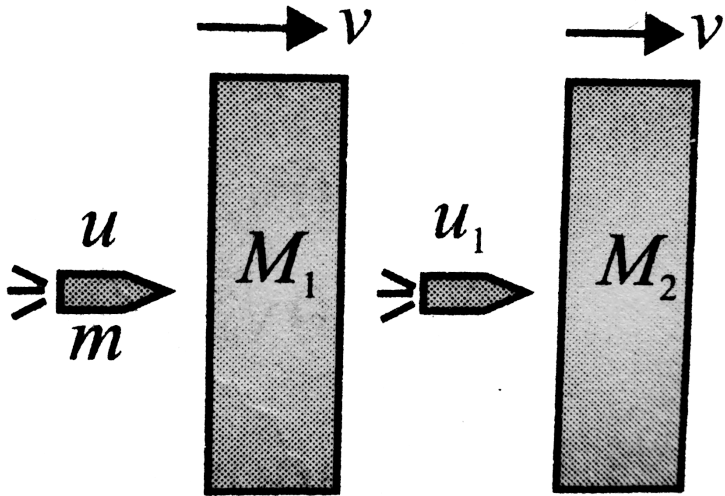

A. 50 %

B. 25 %

C. 100 %

D. 75 %

Answer: B



Watch Video Solution

4. A particle of mass m is moving horizontally with a constant velocity v towards a rigid wall that is moving in opposite direction with a constant speed u . Assuming elastic impact between the particle and wall, the work done by the wall in reflecting the particle is equal to

A. $\left(\frac{1}{2}\right)m(u + v)^2$

B. $\left(\frac{1}{2}\right)m(u + v)$

C. $\left(\frac{1}{2}\right)muv$

D. none of these

Answer: D



Watch Video Solution

5. Two identical balls A and B are released from the positions shown in the figure. They collide elastically on horizontal portion MN. The ratio of heights attained by A and B after collision

will be (neglect friction)

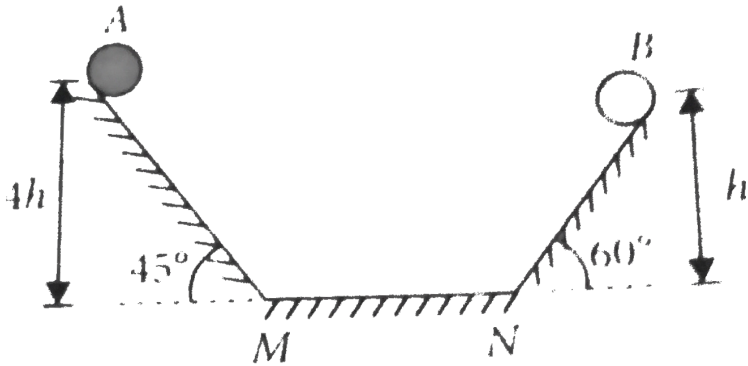

A. 1:4

B. 2:1

C. 4:13

D. 2:5

Answer: C



Watch Video Solution

6. Block A of mass $M = 2\text{kg}$ is connected to another block B of mass $m = 1\text{kg}$ with a string and a spring of force constant $k = 600\text{N/m}$ as shown in Fig. Initially, spring is compressed to 10cm and whole system is moving on a smooth surface with a velocity $v = 1\text{m/s}$. At any time, thread is burnt, the velocity of block A , when B is having maximum

velocity w.r.t. ground, is

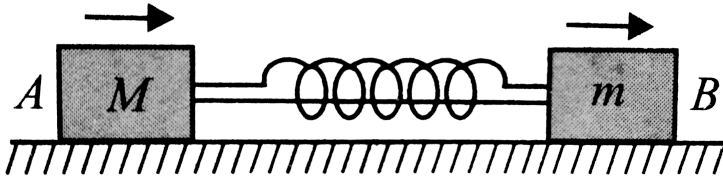

A. zero

B. $1m / S$

C. $3m / s$

D. none of these

Answer: C



Watch Video Solution

7. Two identical blocks, each having mass M , are placed as shown in figure. These two blocks A and B are smoothly conjugated, so that when another block C of mass m passes from A to B there is no jerk. All the surfaces are frictionless, and all three blocks are free to move. Block C is released from rest, then

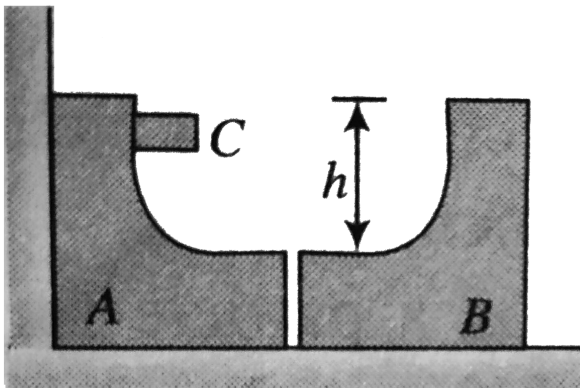

A. when in is at the highest position on B

B. when in is at the lowest position and moving left.

C. when in is at C

D. when in is at lowest position and moving right.

Answer: B



Watch Video Solution

8. A bob of mass $10m$ is suspended through an inextensible string of length l . When the bob is at rest in equilibrium position, two particles, each of mass m , strike it as shown in Fig. The particles stick after collision. Choose the correct statement from the following:

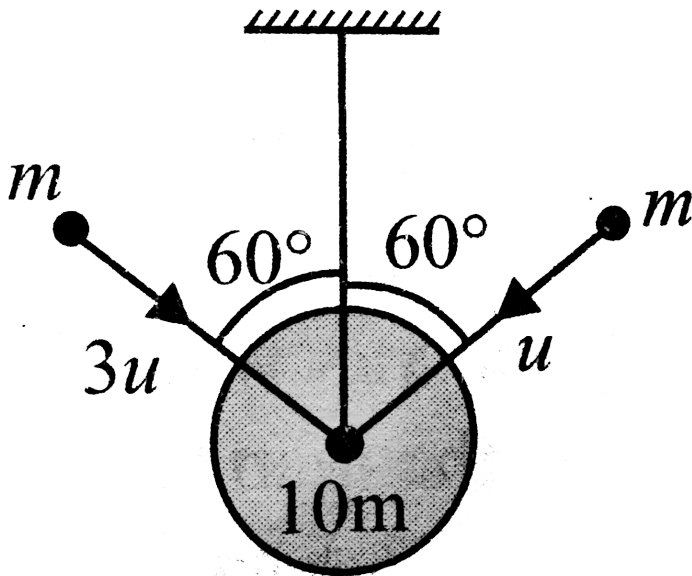

A. Impulse in the string due to tension is

$$2mu$$

B. Velocity of the system just after collision

$$\text{is } v = \frac{u\sqrt{3}}{14}$$

C. Loss of energy is $\frac{137}{28}mu^2$

D. Loss of energy is $\frac{137}{56}mu^2$

Answer: A



Watch Video Solution

9. In Fig., a hollow tube of mass M is free in horizontal direction. The system is released from rest. There is no friction present. The tube and blocks are taken as system.

i. Momentum of the system is conserved in x -direction.

ii. Speed of A w.r.t. $M =$ speed of B w.r.t. M .

iii. Trajectory of centre of mass is X -constant.

iv. Centre of mass has finite acceleration.

Evaluate the above statements and choose the correct option from the following:

Statements i, ii are true and iii, iv are false.

Statements i, ii are false and iii, iv are true.

All statements are true.

All statements are false.

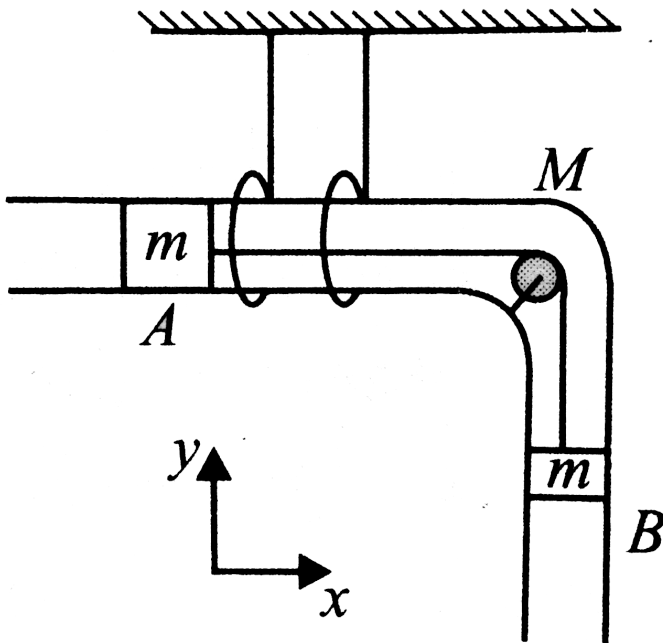

A. Statements i, ii are true and iii, iv are false.

B. Statements i, ii are false and iii, iv are true.

C. All statements are true.

D. All statements are false.

Answer: C



Watch Video Solution

10. A particle of mass m travelling with velocity v and kinetic energy E collides elastically to another particle of mass nm , at rest. What is

the fraction of total energy retained by the particle of mass m ?

A. $\left(\frac{n+1}{n}\right)^2$

B. $\left(\frac{n+1}{(n-1)^2}\right)$

C. $\left(\frac{n-1}{n+1}\right)^2$

D. none of these

Answer: C



Watch Video Solution

11. A ball of mass 'm' moving with speed 'u' undergoes a head-on elastic collision with a ball of mass 'nm' initially at rest. Find the fraction of the incident energy transferred to the second ball.

A. $\frac{n}{1+n}$

B. $\frac{n}{(1+n)^2}$

C. $\frac{2n}{(1+n)^2}$

D. $\frac{4n}{(1+n)^2}$

Answer: D



Watch Video Solution

12. A trolley was moving horizontally on a smooth ground with velocity v with respect to the earth. Suddenly a man starts running from rear end of the trolley with a velocity $(3/2)v$ with respect to the trolley. After reaching the other end, the man turns back and continues running with a velocity $(3/2)v$ with respect to trolley in opposite direction. If the length of the trolley is L , find the displacement of the man with respect to earth when he reaches

the starting point on the trolley. Mass of the trolley is equal to the mass of the man.

A. $\frac{4}{3}L$

B. $\frac{2}{3}L$

C. $\frac{5L}{3}$

D. $1.5L$

Answer: C



Watch Video Solution

13. In a figure shown mass of A and B is equal to M each. Friction between B and lowermost surface is negligible. Initially both the blocks are at rest. The dimensions of the block A are very small. A constant horizontal force F is applied on the blocks B and both the blocks start moving together without any relative motion. Suddenly, the block B encounters a fixed obstacle and comes to rest. The block A continues to slide on the block B . The block A just manages to reach the opposite end of the block B . What is the coefficient of friction

between the two blocks? (Required length are shown in figure)

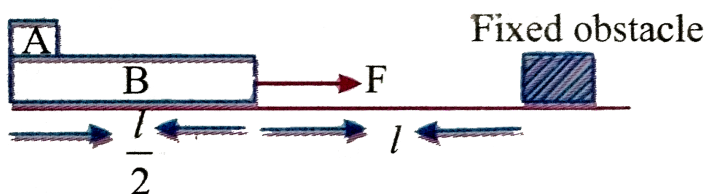

A. $\frac{F}{M}g$

B. $2\frac{F}{M}g$

C. $\frac{F}{2}Mg$

D. none of these

Answer: A



Watch Video Solution

14. Two blocks of masses m and $4m$ lie on a smooth horizontal surface connected with a spring in its natural length. Mass m is given velocity v_0 through an impulse as shown in Fig. Which of the following is not true about subsequent motion?

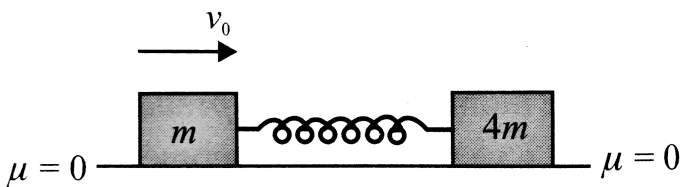

A. Kinetic energy is maximum in ground frame and centre of mass (CM) frame

simultaneously

B. Value of maximum and minimum kinetic energy is same in CM and ground frame

C. Minimum kinetic energy is zero in CM frame but non-zero in ground frame.

D. Maximum and minimum kinetic energy of m in ground frame is, respectively $\frac{1}{2}mv_0^2$ and zero.

Answer: B



Watch Video Solution

15. A vessel at rest explodes breaking it into three pieces. Two pieces having equal mass fly off perpendicular to one another with the same speed of $30m/s$. The third piece has three times the mass of each of the other two pieces. What is the direction (w.r.t. the pieces having equal masses) and magnitude of its velocity immediately after the explosion?

A. $10\sqrt{2}$, 135°

B. $10\sqrt{2}$, 90°

C. $10\sqrt{2}, 60^\circ$

D. $10\sqrt{2}, 30^\circ$

Answer: A



Watch Video Solution

16. A stationary body of mass $3kg$ explodes into three equal pieces. Two of the pieces fly off at right angles to each other. One with a velocity of $2\hat{i}m/s$ and the other with velocity of $3\hat{j}m/s$. If the explosion takes place in 10^{-5}

the average force acting on the third piece in
newtons

A. $(2\hat{i} + 3\hat{j}) \times 10^{-5}$

B. $-(2\hat{i} + 3\hat{j}) \times 10^5$

C. $(3\hat{j} + 2\hat{j}) \times 10^5$

D. $-(2\hat{i} + 3\hat{j}) \times 10^5$

Answer: B



Watch Video Solution

17. A ball of mass m collides horizontally with a stationary wedge of mass m on a rough horizontal surface, in the two orientations as shown. Neglect friction between the ball and the wedge. The students comment on the system of ball and wedge in these situations

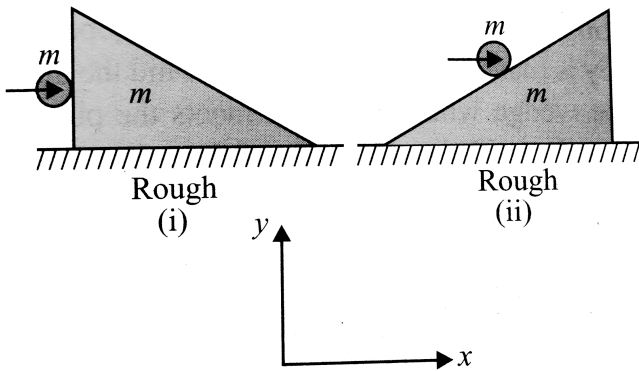

Saurav:

Momentum of the system in x -direction will change by significant amount in both the

cases. Rahul: There are no impulsive external forces in x -direction in both cases, hence the total momentum of the system in x -direction can be treated as conserved in both cases.

- A. Saurav is incorrect and Rahul is correct
- B. Saurav is correct and Rahul is incorrect
- C. Both are correct
- D. Both are incorrect

Answer: D



Watch Video Solution

18. A body is hanging from a rigid support. by an inextensible string of length '1' . It is struck inelastically by an identical body of mass m with horizontal velocity $v = \sqrt{2gl}$ the tension in the string increases just after the striking by

A. mg

B. $3mg$

C. $2mg$

D. none of these

Answer: C



Watch Video Solution

19. A ball is let fall from a height h_0 . There are n collisions with the earth. If the velocity of rebound after n collisions is v_n and the ball rises to a height h_n then coefficient of restitution e is given by

A. $e^n = \sqrt{\frac{h_n}{h_0}}$

B. $e^n = \sqrt{\frac{h_0}{h_n}}$

$$\text{C. } ne = \sqrt{\frac{h_0}{h_0}}$$

$$\text{D. } \sqrt{ne} = \sqrt{\frac{h_n}{h_0}}$$

Answer: A



Watch Video Solution

20. A body X with a momentum p collides with another identical stationary body Y one dimensionally. During the collision, Y gives an impulse J to body X . Then coefficient of restitution is

A. $\frac{2J}{p} - 1$

B. $\frac{J}{P} + 1$

C. $\frac{J}{P} - 1$

D. $\frac{J}{2P} - 1$

Answer: A



Watch Video Solution

21. A pendulum consists of a wooden bob of mass m and length l . A bullet of mass m_1 is fired towards the pendulum with a speed v_1

and it emerges from the bob with speed $\frac{v_1}{3}$.

The bob just completes motion along a vertical circle. Then, v_1 is

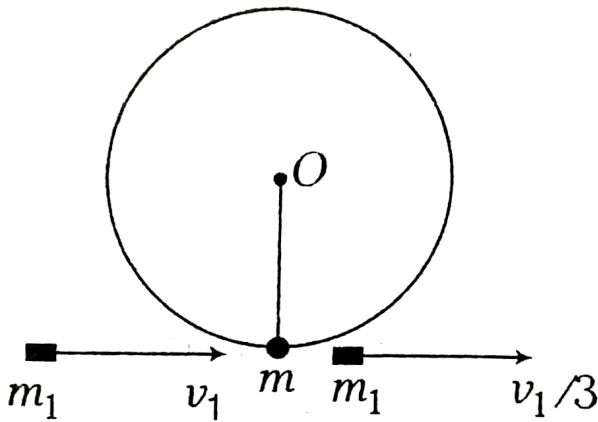

- A. $\left(\frac{m}{m_1}\right) \sqrt{5gl}$
- B. $\frac{3}{2} \left(\frac{m}{m_1}\right) \sqrt{5gl}$
- C. $\frac{2}{3} \left(\frac{m_1}{m}\right) \sqrt{5gl}$
- D. $\left(\frac{m_1}{m}\right) \sqrt{gl}$

Answer: B



Watch Video Solution

22. Two pendulums each of length l are initially situated as shown in Fig. The first pendulum is released and strikes the second. Assume that the collision is completely inelastic and neglect the mass of the string and any frictional effects. How high does the centre of mass rise

after the collision?

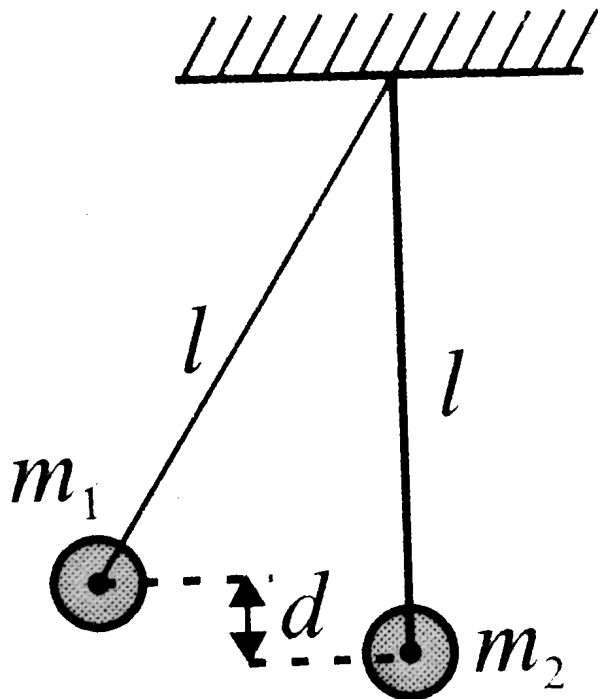

A. $d \left[\frac{m_1}{(m_1 + m_2)} \right]^2$

B. $d \left[\frac{m_1}{(m_1 + m_2)} \right]$

C. $d \left[\frac{(m_1 + m_2)}{m_2} \right]^2$

$$D. \left[\frac{m_2}{(m_1 + m_2)} \right]^2$$

Answer: A



Watch Video Solution

23. A wooden block of mass $10g$ is dropped from the top of a tower $100m$ high. Simultaneously, a bullet of mass $10g$ is fired from the foot of the tower vertically upwards with a velocity of $100m/s$. If the bullet is embedded in it, how high will the block rise

above the top of tower before it starts falling?

$$(g = 10 \text{ m} / \text{s}^2)$$

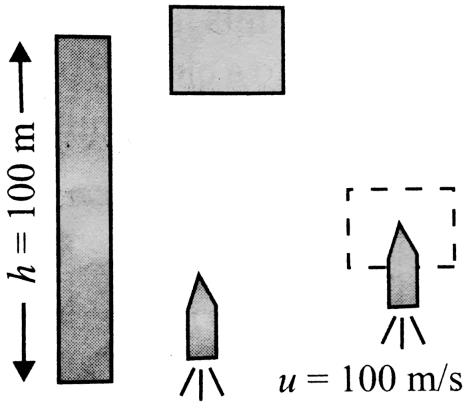

A. 75 m

B. 85 m

C. 80 m

D. 10 m

Answer: A



Watch Video Solution

24. A machinist starts with three identical square plates but cuts one corner from one of them, two corners from the second and three corners from the third. Rank the three according to the x -coordinate of their centre

of mass, from smallest to largest.

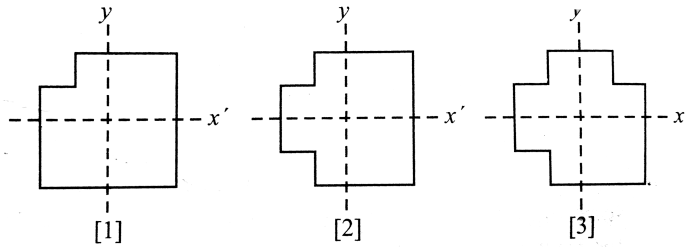

A. 3, 1, 2

B. 1, 3, 2

C. 3, 2, 1

D. 1 and 3 tie, then 2

Answer: B



Watch Video Solution

25. A particle of mass $2m$ is projected at an angle of 45° with horizontal with a velocity of $20\sqrt{2}m/s$. After 1 s explosion takes place and the particle is broken into two equal pieces. As a result of explosion one part comes to rest. The maximum height from the ground attained by the other part is ($g = 10 m/s^2$)

A. $50m$

B. $25m$

C. $40m$

D. $35m$

Answer: D



Watch Video Solution

26. A sphere is moving with velocity vector $2\hat{i} + 2\hat{j}$ immediately before it hits a vertical wall. The wall is parallel to \hat{j} and the coefficient of restitution of the sphere and the wall is $e = \frac{1}{2}$. Find the velocity of the sphere after it hits the wall?

A. $\hat{i} - \hat{j}$

B. $-\hat{i} + 2\hat{j}$

C. $-\hat{i} - \hat{j}$

D. $2\hat{i} - \hat{j}$

Answer: B



Watch Video Solution

27. Two equal spheres A and B lie on a smooth horizontal circular groove at opposite ends of a diameter. At time $t = 0$, A is projected along the groove and it first impinges on B at time

$t = T_1$ and again at time $t = T_2$. If e is the coefficient of restitution, the ratio T_2/T_1 is

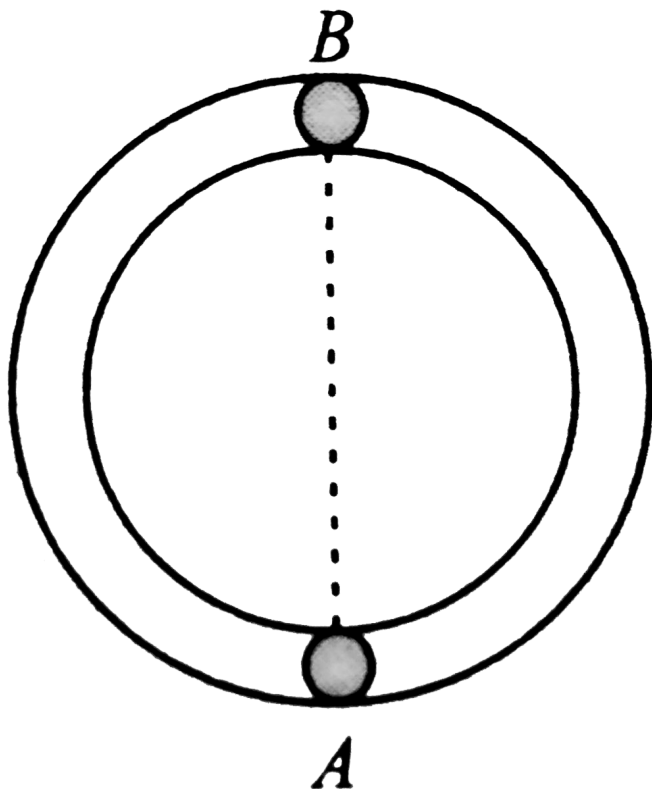

A. $\frac{2}{e}$

B. $\frac{(2 + e)}{2}$

C. $\frac{2(e + 1)}{e}$

D. $\frac{(2 + e)}{e}$

Answer: D



Watch Video Solution

28. A block 'A' of mass m_1 hits horizontally the rear side of a spring (ideal) attached to a block B of mass m_2 resting on a smooth horizontal surface. After hitting, 'A' gets attached to the spring.

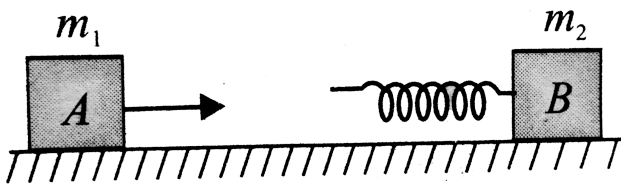

Some statements are given at any moment of time:

i. If velocity of A is greater than B , then kinetic energy of the system will be decreasing.

ii. If velocity of A is greater than B , then kinetic energy of the system will be increasing.

iii. If velocity of A is greater than B , then momentum of the system will be decreasing.

iv. If velocity of A is greater than B , then momentum of the system will be increasing.

Now select correct alternative:

A. only iv

B. only i

C. ii and iv

D. i and ii

Answer: B



Watch Video Solution

29. A particle of mass $4m$ is projected from the ground at some angle with horizontal. Its horizontal range is R . At the highest point of

its path it breaks into two pieces of masses m and $3m$, respectively, such that the smaller mass comes to rest. The larger mass finally falls at a distance x from the point of projection, where x is equal to

A. $\frac{2R}{3}$

B. $\frac{7R}{6}$

C. $\frac{5R}{4}$

D. none of these

Answer: B



Watch Video Solution

30. A block of mass M is tied to one end of a massless rope. The other end of the rope is in the hands of a man of mass $2M$ as shown in Fig. The block and the man are resting on a rough wedge of mass M . The whole system is resting on a smooth horizontal surface. The man starts walking towards right while holding the rope in his hands. Pulley is massless and frictionless. Find the displacement of the wedge when the block

meets the pulley. Assume wedge is sufficiently long so that man does not fall down.

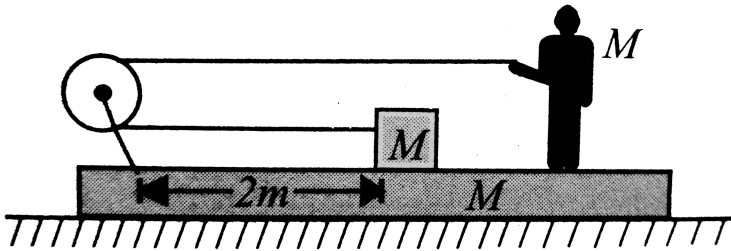

- A. $\frac{1}{2}m$ towards right
- B. $\frac{1}{2}m$ towards left
- C. The wedge does not move at all
- D. $1m$ towards left

Answer: B



Watch Video Solution

31. A particle of mass m_1 moving with velocity v in a positive direction collides elastically with a mass m_2 moving in opposite direction also at velocity v . If $m_2 > m_1$, then

A. the velocity of m_1 immediately after collision is nearly $3v$

B. the change in momentum of m_1 is nearly $4m_1v$

C. the change in kinetic energy of m_1 is

nearly $4mv_2$

D. all of the above

Answer: D



Watch Video Solution

32. A strip of wood of mass M and length l is placed on a smooth horizontal surface. An insect of mass m starts at one end of the strip and walks to the other end in time t , moving

with a constant speed. The speed of the insect as seen from the ground is

A. $\frac{l}{t} \left(\frac{M}{M + m} \right)$

B. $\frac{l}{t} \left(\frac{m}{M + m} \right)$

C. $\frac{l}{t} \left(\frac{M}{m} \right)$

D. $\frac{l}{t} \left(\frac{m}{M} \right)$

Answer: A



Watch Video Solution

33. The system in Fig. is released from rest from the position shown. After blocks have moved distance $H/3$, collar B is removed and block A and C continue to move. The speed of C just before it strikes the ground is

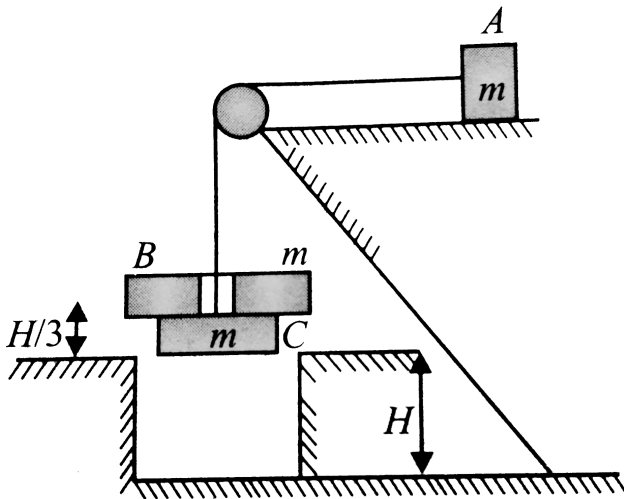

A. $\frac{4}{3} \sqrt{gH}$

B. $2 \frac{\sqrt{gH}}{3}$

C. $\frac{\sqrt{(13gH)}}{3}$

D. $2\sqrt{2gH}$

Answer: C



Watch Video Solution

34. A car of mass m is initially at rest on the boat of mass M tied to the wall of dock through a massless, inextensible string. The car accelerates from rest to velocity v_0 in times

to. At $t = t_0$ the car applies brake and comes to rest relative to the boat in negligible time. Neglect friction between the boat and water: the time ' t ' at which boat will strike the wall is

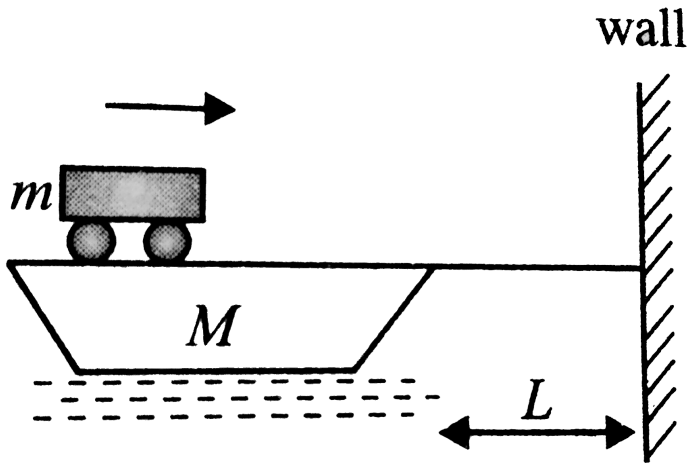

- A. $\frac{L(M + m)}{mv_0}$
- B. $t_0 + \frac{L(M + m)}{mv_0}$
- C. $t_0 + \frac{L(M + m)}{Mv_0}$

D. none of these

Answer: B



Watch Video Solution

35. A particle of mass m moving with velocity $1m/s$ collides perfectly elastically with another particle of mass $2m$. If the incident particle is deflected by 90° . The heavy mass will make an angle θ with the initial direction of m equal to:

A. 60°

B. 45°

C. 15°

D. 30°

Answer: D



Watch Video Solution

36. A canon shell moving along a straight line bursts into two parts. Just after the burst one part moves with momentum $20Ns$ making an

angle 30° with the original line of motion. The minimum momentum of the other part of shell just after the burst is

A. $0Ns$

B. $5Ns$

C. $10Ns$

D. $17.32Ns$

Answer: C



Watch Video Solution

37. Figure shows a hollow cube of side ' a ' and volume ' V '. There is a small chamber of volume $V/4$ in the cube as shown. The chamber is completely filled by in kg of water. Water leaks through a hole H and spreads in the whole cube. Then the work done by gravity in this process assuming that the complete

water finally lies at the bottom of the cube is

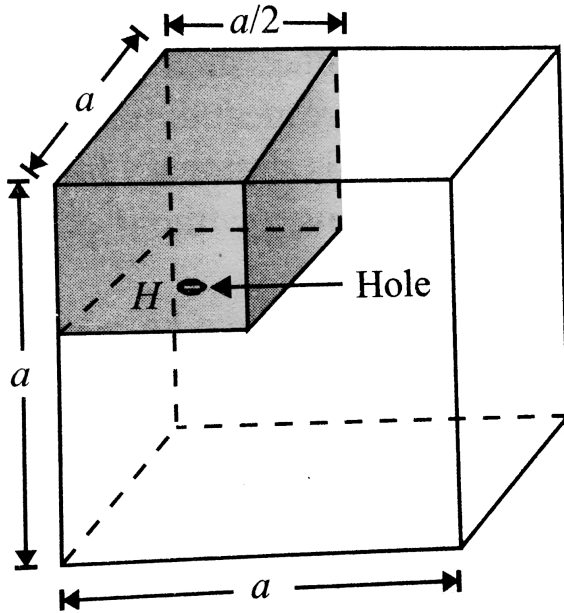

A. $\frac{1}{2}mga$

B. $\frac{3}{8}mga$

C. $\frac{5}{8}mga$

D. $\frac{1}{8}mga$

Answer: C



Watch Video Solution

38. Two men ' A ' and ' B ' are standing on a plank. ' B ' is at the middle of the plank and ' A ' is at the left end of the plank. Lower surface of the plank is smooth. System is initially at rest and masses are as shown in Fig. ' A ' and ' B ' start moving such that the position of ' B ' remains fixed with respect to ground, then ' A ' meets ' B '. Then the point

where A meets B is located at

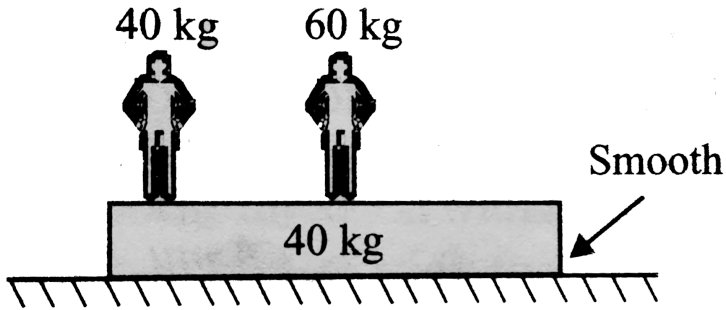

- A. the middle of the plank
- B. 30cm from the left of the plank
- C. the right end of the plank
- D. none of these

Answer: C



Watch Video Solution

39. A gun which fires small balls of mass $20g$ is firing $20balls$ per second on the smooth horizontal table surface $ABCD$. If the collision is perfectly elastic and balls are striking at the centre of table with a speed of $5m/s$ at an angle of 60° with the vertical just before collision, then force exerted by one of the legs on ground is (assume total weight of

the table is 0.2kg)

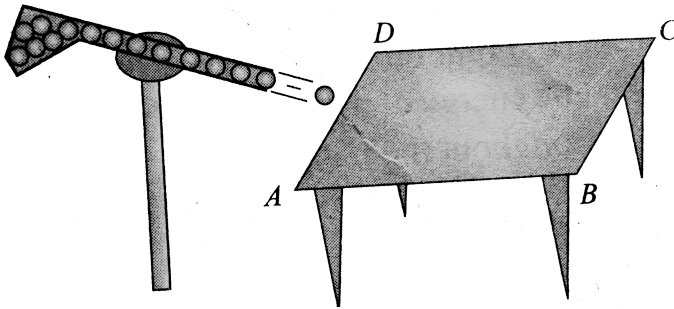

A. 0.5N

B. 1N

C. 0.25N

D. 0.75N

Answer: B



Watch Video Solution

40. Figure shows the velocity-time graph for two masses R and S that collided elastically.

Which of the following statements is true?

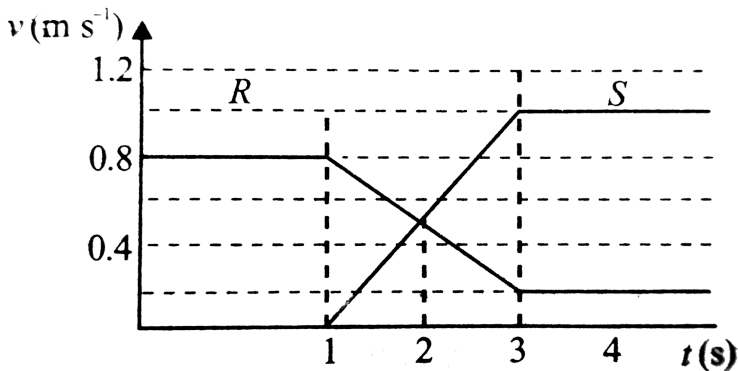

- i. R and S moved in the same direction after the collision.
- ii. The velocities of R and S were equal at the mid time of the collision.

iii. The mass of R was greater than mass of S .

Which of the following is true?

A. i only

B. ii only

C. i and ii only

D. i,ii, and iii

Answer: D



Watch Video Solution

41. A system of two blocks A and B are connected by an inextensible massless string as shown in Fig. The pulley is massless and frictionless. Initially, the system is at rest. A bullet of mass m moving with a velocity u as shown hits block A and gets embedded into it. The impulse imparted by tension force to the

block of mass $3m$ is

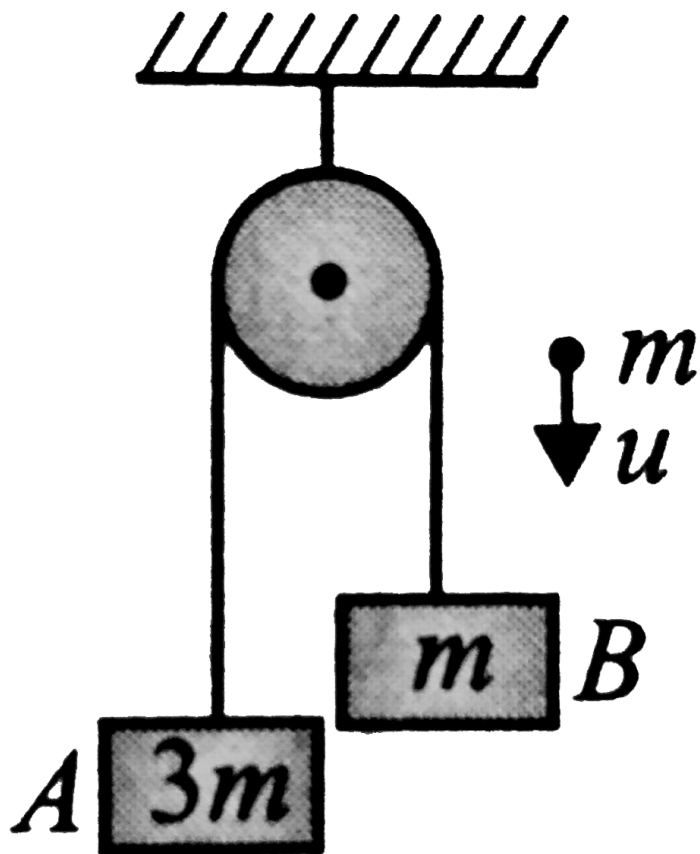

A. $\frac{5mu}{4}$

B. $\frac{4mu}{5}$

C. $\frac{2mu}{5}$

D. $\frac{3\mu}{5}$

Answer: D



Watch Video Solution

42. A stationary body explodes in to four identical fragments such that three of them fly mutually perpendicular to each other, each with same $KE(E_0)$. The energy of explosion will be

A. $6E_0$

B. $\frac{4E_0}{3}$

C. $4E_0$

D. $8E_0$

Answer: A



Watch Video Solution

43. A man stands at one end of the open truck which can run on frictionless horizontal rails. Initially, the man and the truck are at rest. Man

now walks to the other end and stops. Then which of the following is true?

A. The truck moves opposite to direction of motion of the man even after the man ceases to walk.

B. The centre of mass of the man and the truck remains at the same point throughout the man's walk

C. The kinetic energy of the man and the truck are exactly equal throughout the

man's walk.

D. The truck does not move at all during the man's walk.

Answer: B



Watch Video Solution

44. Figure shows a thin uniform rod 50cm long and has a mass of 100g . A hollow metal ball is filled with air and has a diameter 10cm and total mass 50g is fixed to one end of the rod.

At what point along its length will the ball and rod balance horizontally?

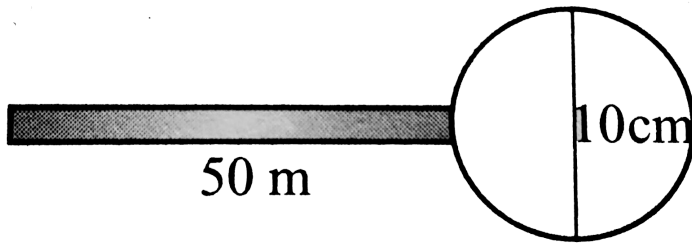

- A. 20cm from the centre of the rod
- B. 10cm from the centre of the rod
- C. at the centre of the rod
- D. where the ball is attached to the rod

Answer: B



Watch Video Solution

45. A hockey player receives a corner shot at a speed of 15m/s at angle 30° with y -axis and then shoots the ball along x -axis with the speed 30m/s . If the mass of the ball is 150g and it remains in contact with the hockey stick for 0.01s , the force exerted on the ball along x

-axis is

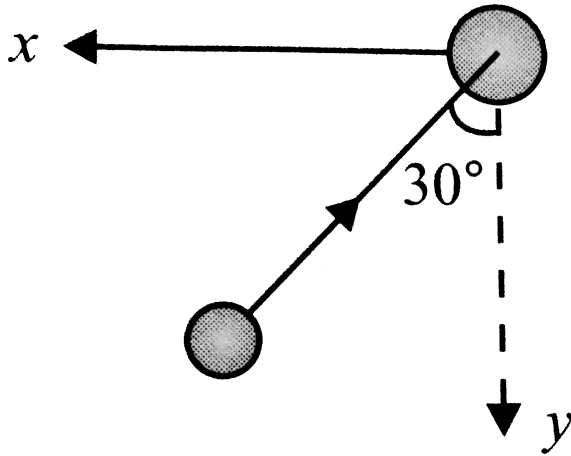

A. 281N

B. 187.5N

C. 562.5N

D. 375N

Answer: C



46. A ball is dropped from a height of $45m$ from the ground. The coefficient of restitution between the ball and the ground is $\frac{2}{3}$. What is the distance travelled by the ball in 4^{th} second of its motion. Assume negligible time is spent in rebounding. Let $g = 10ms^{-2}$

A. $5m$

B. $20m$

C. $15m$

D. $10m$

Answer: C



Watch Video Solution

47. P and Q are two identical masses at rest suspended by an inextensible string passing over a smooth frictionless pulley. Mass P is given a downward push with a speed v as shown in Fig. It collides elastically with the floor and rebounds immediately. What

happens immediately after collision?

d. 10 m

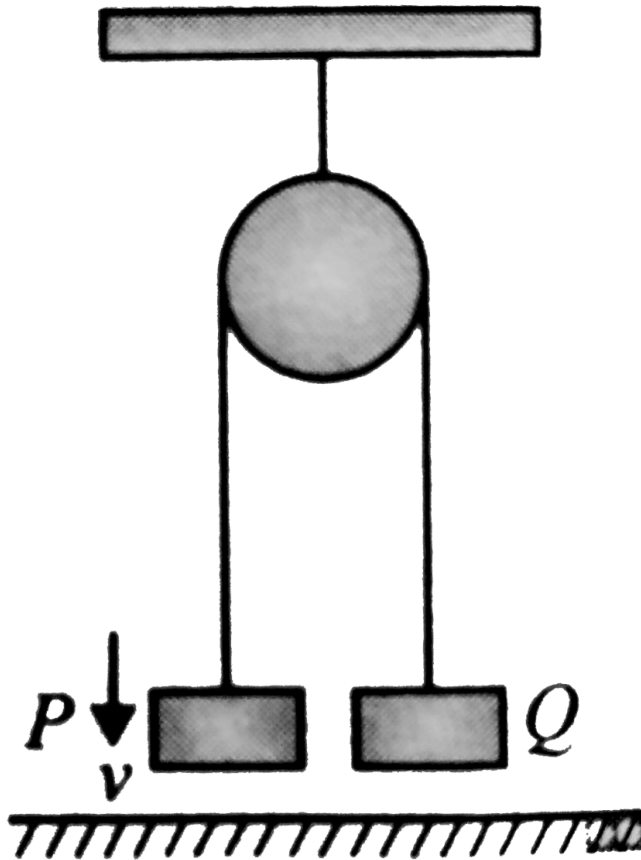

A. P and Q both move upwards with equal speeds.

B. P and Q both move upwards with different speeds

C. P moves upwards and Q moves downwards with equal speeds.

D. Both P and Q are at rest.

Answer: A



Watch Video Solution

48. A bag of mass M hangs by a long massless rope. A bullet of mass m , moving horizontally with velocity u , is caught in the bag. Then for the combined (bag + bullet) system, just after collision

A. momentum is $muM / (M + m)$

B. kinetic energy is $mu^2 / 2$

C. momentum is $mu(M + m) / M$

D. kinetic energy is $m^2u^2 / 2(M + m)$

Answer: D



Watch Video Solution

49. A man stands at one end of a boat which is stationary in water. Neglect water resistance.

The man now moves to the other end of the boat and again becomes stationary. The centre of mass of the 'man plus boat' system will remain stationary with respect to water

A. only when the man is stationary initially
and finally

B. only if the man moves without
acceleration on the boat

C. only if the man and the boat have equal
masses

D. in all cases

Answer: D



Watch Video Solution

50. Two particles are shown in figure. At $t = 0$ a constant force $F = 6N$ starts acting on $3kg$. Find the velocity of circle of mass of these particle at $t = 5s$.

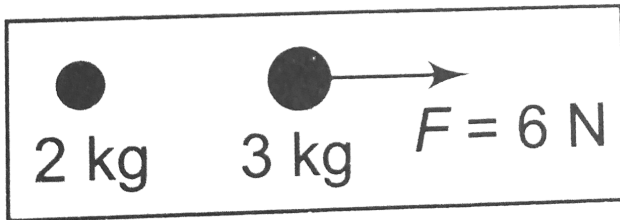

A. 5 m / s

B. 4 m / s

C. 6 m / s

D. $3m / s$

Answer: C



Watch Video Solution

51. Two blocks of masses $5kg$ and $2kg$ are placed on a frictionless surface and connected by a spring. An external kick gives a velocity of $14m / s$ to the heavier block in the direction of lighter one. The magnitudes of velocities of

two blocks in the centre of mass frame after the kick are, respectively,

A. $4m / s, 4m / s$

B. $10m / s, 4m / s$

C. $4m / s, 10m / s$

D. $10m / s, 10m / s$

Answer: C



Watch Video Solution

52. In a system of particles $8kg$ mass is subjected to a force of $16N$ along +ve x -axis and another $8kg$ mass is subjected to a force of $8N$ along +ve y -axis. The magnitude of acceleration of centre of mass and the angle made by it with x -axis are given, respectively, by

A. $\frac{\sqrt{5}}{2}ms^{-2}$, $\theta = 45^\circ$

B. $3\sqrt{5}ms^{-2}$, $\theta = \tan^{-1}\left(\frac{2}{3}\right)$

C. $\frac{\sqrt{5}}{2}ms^{-2}$, $\theta = \tan^{-1}\left(\frac{1}{2}\right)$

D. $1ms^{-2}$, $\theta = \tan^{-1}\sqrt{3}$

Answer: C



Watch Video Solution

53. A circular plate of uniform thickness has a diameter of 28cm . A circular portion of diameter 21cm is removed from the plate as shown. O is the centre of mass of complete plate. The position of centre of mass of remaining portion will shift towards left from

'O' by

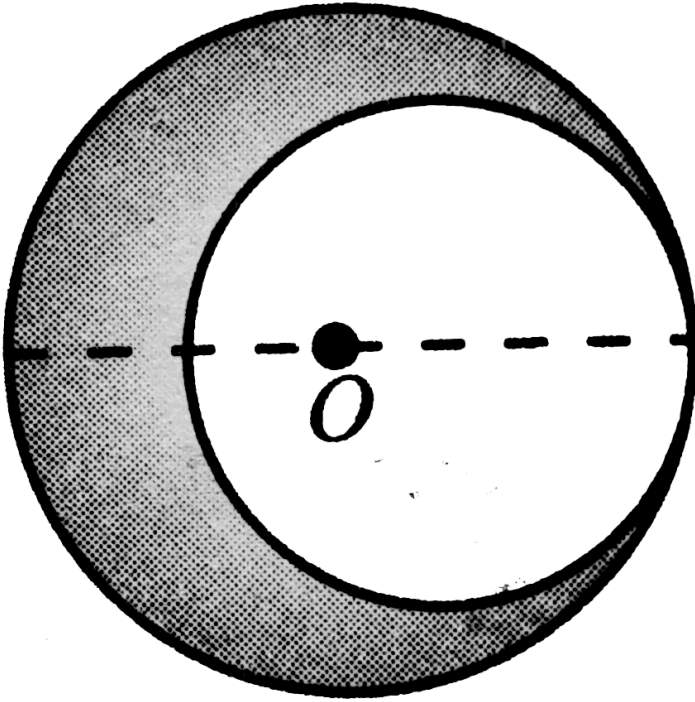

A. 5cm

B. 9cm

C. 4.5cm

D. 5.5cm

Answer: C



Watch Video Solution

54. A heavy chain of length $1m$ and weight $20kg$ hangs vertically with one end attached to a peg and carries a block of mass $10kg$ at the other end. Find the work done in winding $50cm$ of chain round the peg.

A. $85J$

B. $100J$

C. $120J$

D. $125J$

Answer: D



Watch Video Solution

55. A cannon of mass $1000kg$ located at the base of an inclined plane fires a shell of mass $50kg$ in horizontal direction with velocity $180km/h$. The angle of inclination of the inclined plane with the horizontal is 45° . The

coefficient of friction between the cannon and inclined plane is 0.5. The maximum height, in metre, to which the cannon can ascend the inclined plane as a result of recoil is

A. $\frac{5}{6}$

B. $\frac{5}{24}$

C. $\frac{5}{12}$

D. none of these

Answer: B



Watch Video Solution

56. A U -shaped wire has a semicircular bending between A and B as shown in Fig. A bead of mass m moving with uniform speed v through a wire enters the semicircular bend at A and leaves at B with velocity $v/2$ after time T . The average force exerted by the bead on the part AB of the wire is

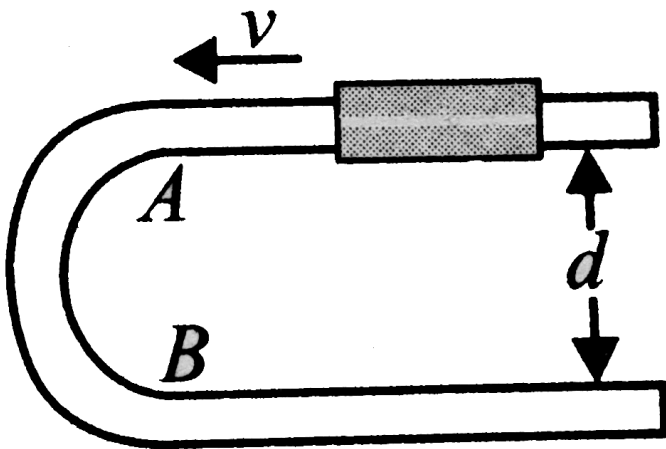

A. 0

B. $\frac{3mv}{2T}$

C. $\frac{3mv}{T}$

D. none of these

Answer: B



Watch Video Solution

57. A particle of mass $2kg$ moving with a velocity of $3m/s$ is acted upon by a force which changes its direction of motion by an

angle of 90° without changing its speed. What is the magnitude of impulse experienced by the particle?

A. $6Ns$

B. $2Ns$

C. $3\sqrt{2}Ns$

D. $6\sqrt{2}Ns$

Answer: D



Watch Video Solution

58. A body of mass $3kg$ moving with a velocity of $4m/s$ towards left collides head on with a body of mass $4kg$ moving in opposite direction with a velocity of $3m/s$. After collision the two bodies stick together and move with a common velocity which is

A. zero

B. $12m/s$ towards left

C. $12m/s$ towards right

D. $\frac{12}{7} m/s$ towards left

Answer: A



Watch Video Solution

59. Two blocks of masses $m_1 = 2kg$ and $m_2 = 4kg$ are moving in the same direction with speeds $v_1 = 6m/s$ and $v_2 = 3m/s$, respectively on a frictionless surface as shown in the figure. An ideal spring with spring constant $k = 30000N/m$ is attached to the back side of m_2 . Then the maximum compression of the spring after collision will

be

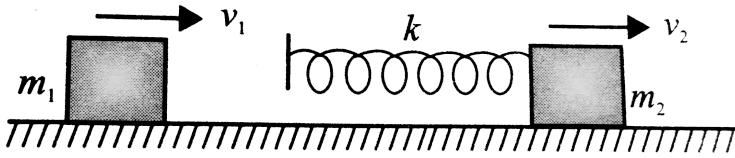

A. $0.06m$

B. $0.04m$

C. $0.02m$

D. none of these

Answer: C



Watch Video Solution

60. A cracker is thrown into air with a velocity of $10ms^{-1}$ at an angle of 45° with the vertical. When it is at a height of $\left(\frac{1}{2}\right)m$ from the ground, it explodes into a number of pieces which follow different parabolic paths. What is the velocity of center of mass, when it is at a height of 1m from the ground? (Take, $g = 10ms^{-2}$]

A. $4\sqrt{5}m / s$

B. $2\sqrt{5}m / s$

C. $5\sqrt{4}m / s$

D. $10m / s$

Answer: A



Watch Video Solution

61. A force exerts an impulse I on a particle changing its speed from initial velocity u to final velocity $2u$. The applied force and the initial velocity are oppositely oriented along the same line. The work done by the force is

A. $\frac{3}{2}Iu$

B. $\frac{1}{2}Iu$

C. Iu

D. $2Iu$

Answer: B



Watch Video Solution

62. A ball falls vertically onto a floor with momentum p and then bounces repeatedly. If coefficient of restitution is e , then the total momentum imparted by the ball to the floor is

A. $p(1 + e)$

B. $\frac{p}{1 - e}$

C. $p\left(1 + \frac{1}{e}\right)$

D. $\left(\frac{1 + e}{1 - e}\right)$

Answer: D



Watch Video Solution

63. A ball released from a height h_0 above a horizontal surface rebounds to a height h_1 , after one bounce. The graph that relates h_0 to

h_1 is shown Fig. If the ball (of the mass m) was dropped from an initial height h and made three bounces, the kinetic energy of the ball immediately after the third impact with the surface was

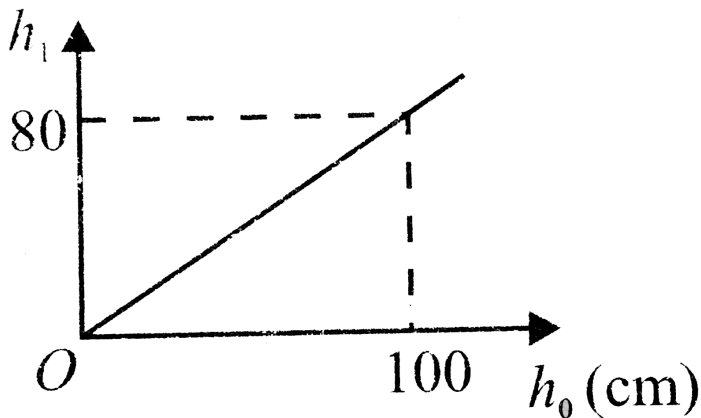

A. $(0.8)^3 mgh$

B. $(0.8)^2 mgh$

C. $0.8mg(h/3)$

D. $\left[1 - (0.8)^3\right]mgh$

Answer: A



Watch Video Solution

64. Two identical balls of equal masses A and B, are lying on a smooth surface as shown in the figure. Ball A hits the ball B (which is at rest) with a velocity $v = 16ms^{-1}$. What should be the minimum value of coefficient of restitution

e between A and B so that B just reaches the highest point of inclined plane?

$$(g = 10ms^{-2})$$

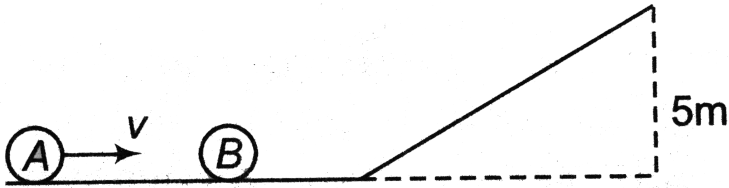

(c) $\frac{1}{2}$

A. $\frac{2}{3}$

B. $\frac{1}{4}$

C. $\frac{1}{2}$

D. $\frac{1}{3}$

Answer: B



Watch Video Solution

65. A particle of mass m is made to move with uniform speed v_0 along the perimeter of a regular hexagon, inscribed in a circle of radius R . The magnitude of impulse applied at each corner of the hexagon is

A. $2mv_0 \sin \frac{\pi}{6}$

B. $mv_0 \sin \frac{\pi}{6}$

C. $mv_0 \sin \frac{\pi}{3}$

D. $2mv_0 \sin \frac{\pi}{3}$

Answer: A



Watch Video Solution

66. A continuous stream of particles, of mass m and velocity v , is emitted from a source at a rate of n per second. The particles travel along a straight line, collide with a body of mass M and get embedded in the body. If the mass M

was originally at rest, its velocity when it has received N particles will be

A. $\frac{mnN}{Nm + M}$

B. $\frac{mvN}{NM + M}$

C. $\frac{mv}{Nm + M}$

D. $\frac{Nm + M}{NM}$

Answer: B



Watch Video Solution

67. A ball kept in a close box moves in the box making collisions with the walls. The box is kept on a smooth surface. The velocity of the centre of mass

A. of the box remains constant

B. of the (box + ball) system remains constant

C. of the ball remains constant

D. of the ball relative to the box remains constant

Answer: B



Watch Video Solution

68. A particle of mass m moving with a velocity u makes an elastic one-dimensional collision with a stationary particle of mass m establishing a contact with it for extremely small time. T . Their force of contact increases from zero to F_0 linearly in time $T/4$, remains constant for a further time $T/2$ and decreases linearly from F_0 to zero in further time $T/4$ as

shown. The magnitude possessed by F_0 is.

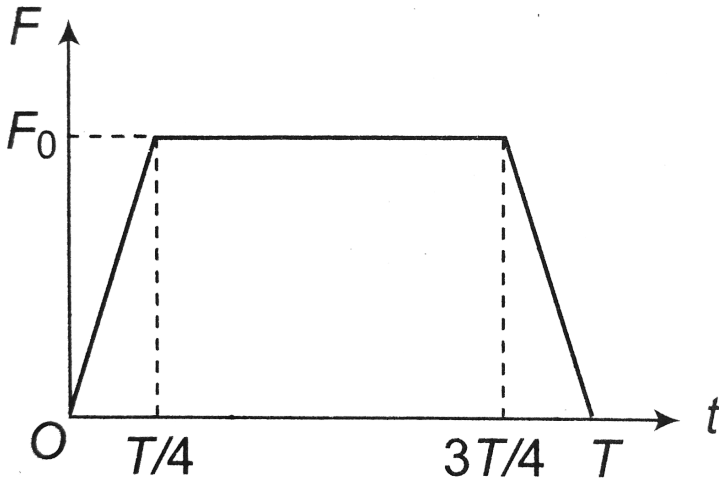

- A. $\frac{mu}{T}$
- B. $\frac{2mu}{T}$
- C. $\frac{4mu}{3T}$
- D. $\frac{3mu}{4T}$

Answer: C



Watch Video Solution

69. A stationary body explodes into two fragments of masses m_1 and m_2 . If momentum of one fragment is p , the energy of explosion is

A. $\frac{p^2}{2(m_1 + m_2)}$

B. $\frac{p^2}{2\sqrt{m_1 m_2}}$

C. $\frac{p^2(m_1 + m_2)}{2m_1 m_2}$

D. $\frac{p^2}{2(m_1 - m_2)}$

Answer: C



Watch Video Solution

70. A ball of mass m is projected with a speed v into the barrel of a spring gun of mass M initially at rest lying on a frictionless surface. The mass sticks in the barrel at the point of maximum compression in the spring. The fraction of kinetic energy of the ball stored in the spring is

A. $\frac{m}{M}$

B. $\frac{M}{m + M}$

C. $\frac{m}{M + M}$

D. none of these

Answer: B



Watch Video Solution

71. A railway flat car has an artillery gun installed on it. The combined system has a mass M and moves with a velocity V . The

barrel of the gun makes an angle α with the horizontal. A shell of mass m leaves the barrel at a speed v relative to the barrel. The speed of the flat car so that it may stop after the firing is

A. $\frac{mv}{M + m}$

B. $\left(\frac{Mv}{M + m}\right) \cos \alpha$

C. $\left(\frac{mv}{M + m}\right) \cos \alpha$

D. $(M + m) \cos \alpha$

Answer: C



Watch Video Solution

72. Two blocks of masses $6kg$ and $4kg$ are attached to the two ends of a massless string passing over a smooth fixed pulley. if the system is released, the acceleration of the centre of mass of the system will be

- A. g , vertically downwards
- B. $\frac{g}{5}$, vertically downwards
- C. $\frac{g}{25}$, vertically downwards
- D. zero

Answer: C



Watch Video Solution

73. The momentum of a moving particle is vectorially given as, $\vec{p} = p_0 (\cos t \hat{i} + \sin t \hat{j})$ where t stands for time. Choose the correct option:

A. The applied force is constant.

B. The momentum is constant.

C. The applied force always remains perpendicular to the momentum.

D. The applied force is always parallel to the momentum.

Answer: C



Watch Video Solution

74. A gun of mass M . fires a shell of mass m horizontally and the energy of explosion is such as would be sufficient to project the shell

vertically to a height 'h'. The recoil velocity of the gun is

A. $\left(\frac{2m^2gh}{M(m+M)} \right)^{\frac{1}{2}}$

B. $\left(\frac{2m^2gh}{M(m-M)} \right)^{\frac{1}{2}}$

C. $\left(\frac{2m^2gh}{2M(m-M)} \right)^{\frac{1}{2}}$

D. $\left(\frac{2m^2gh}{2M(m+M)} \right)^{\frac{1}{2}}$

Answer: A



Watch Video Solution

75. An inverted T -shaped object is placed on a horizontal floor as shown in Fig. A force F is applied on the system as shown in Fig. The value of x so that the system performs pure translational motion is

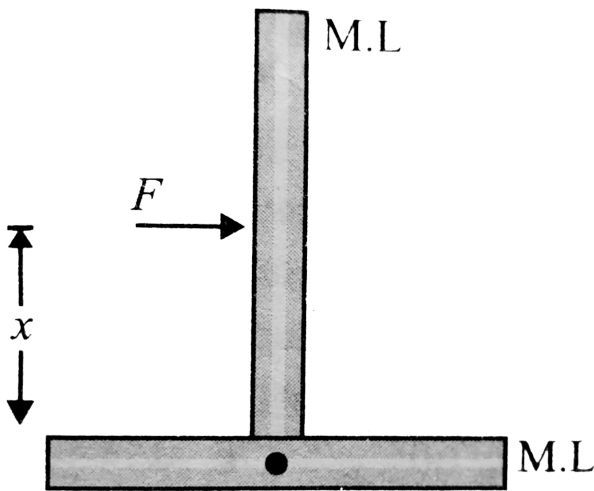

A. $\frac{L}{4}$

B. $\frac{3L}{4}$

C. $\frac{L}{2}$

D. $\frac{3L}{2}$

Answer: A



Watch Video Solution

76. Two blocks m_1 and m_2 are pulled on a smooth horizontal surface, and are joined together with a spring of stiffness k as shown in Fig. Suddenly, block m_2 receives a horizontal

velocity v_0 , then the maximum extension x_m in the spring is

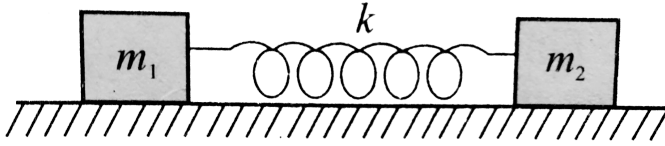

- A. $v_0 \sqrt{\frac{m_1 m_2}{m_1 + m_2}}$
- B. $v_0 \sqrt{\frac{2m_1 m_2}{((m_1 + m_2)k)}}$
- C. $v_0 \sqrt{\frac{m_1 m_2}{2(m_1 + m_2)k}}$
- D. $v_0 \sqrt{\frac{m_1 m_2}{(m_1 + m_2)k}}$

Answer: D



Watch Video Solution

77. A particle at rest is constrained to move on a smooth horizontal surface. Another identical particle hits the fractional particle with a velocity v at an angle $\theta = 60^\circ$ with horizontal. If the particles move together, the velocity of the combination just after impact is equal to

A. v

B. $\frac{v}{2}$

C. $\frac{\sqrt{3}v}{4}$

D. $\frac{v}{4}$

Answer: D



Watch Video Solution

78. A particle of mass m comes down on a smooth inclined plane from point B at a height of h from rest. The magnitude of change in momentum of the particle between position A (just before arriving on horizontal surface) and C (assuming the angle of inclination of the plane as θ with respect to

the horizontal) is

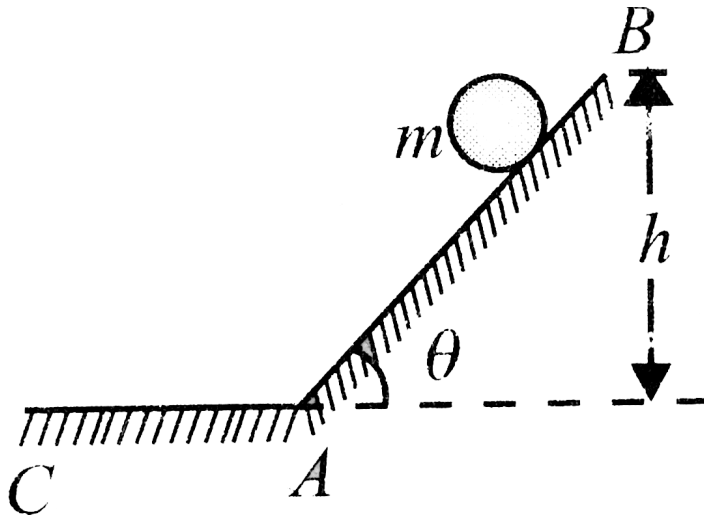

- A. 0
- B. $2m\sqrt{(2gh)} \sin \theta$
- C. $2m\sqrt{(2gh)} \sin\left(\frac{\theta}{2}\right)$
- D. $2m\sqrt{(2gh)}$

Answer: C



Watch Video Solution

79. Three balls A , B and C of masses $2kg$, $4kg$ and $8kg$, respectively, move along the same straight line and in the same direction, with velocities $4m/s$, $1m/s$, $\frac{3}{4}m/s$. If A collides with B and subsequently B collides with C , find the velocity of ball A and ball B after collision, taking the coefficient of restitution as

unity.

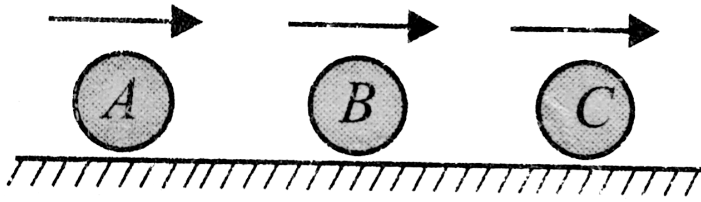

A. $V_A = 3, V_B = 9/4$

B. $V_A = 0, V_B = 3$

C. $V_A = 3, V_B = 0$

D. $V_A = 0, V_B = 0$

Answer: D



Watch Video Solution

80. A ball of mass m moving with velocity v_0 collides with a wall as shown in Fig. After impact it rebounds with a velocity' $(v_0)/2$ The component of impulse acting on the ball along the wall is

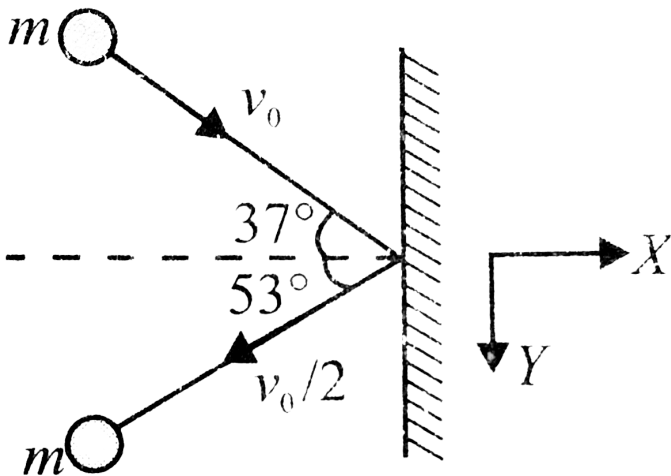

A. $\frac{mv_0}{2} \hat{j}$

B. $-\frac{mv_0}{2} \hat{j}$

C. $-\frac{mv_0}{5} \hat{j}$

D. none of these

Answer: C



Watch Video Solution

81. Five balls are placed one after the other along a straight line as shown in the figure. Initially, all the balls are at rest. Then the second ball has been projected with speed v_0

towards the third ball. Mark the correct statements, (Assume all collisions to be head-on and elastic.)

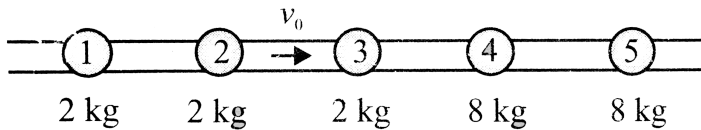

A. Total number of collisions in the process

is 5

B. Velocity of separation between the first

and fifth ball after the last possible

collision is v_0

C. Finally, three balls remain stationary.

D. All of the above

Answer: D



Watch Video Solution

82. Two objects are at rest on a level frictionless surface. The objects are not connected. A force F is applied to one of the objects, which then moves with acceleration a . Mark the correct statement(s).

A. The concept of centre of mass cannot be applied because the external force does not act on both the objects.

B. The centre of mass moves with acceleration that could be greater than a .

C. The centre of mass moves with acceleration that must be equal to a .

D. The centre of mass moves with acceleration that must be less than a .

Answer: D



Watch Video Solution

83. A highly elastic ball moving at a speed of $3m/s$ approaches a wall moving towards it with a speed of $3m/s$. After the collision, the

speed of the ball will be

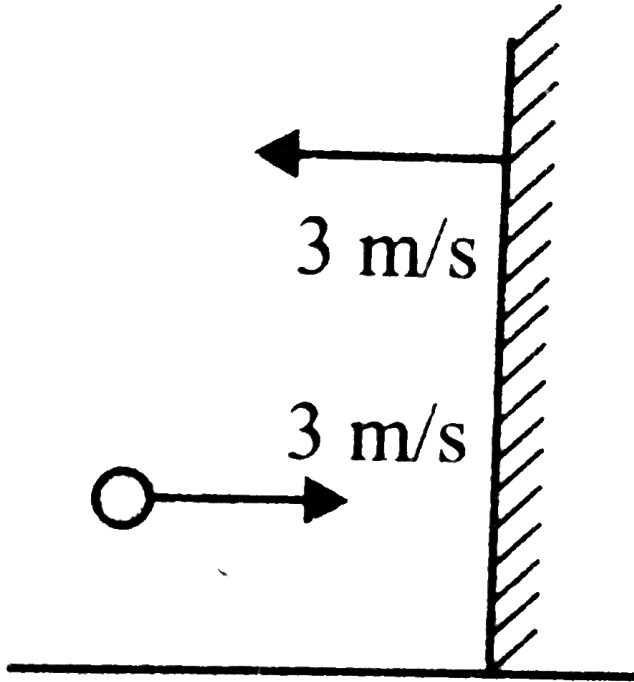

A. $3m / s$

B. $6m / s$

C. $9m / s$

D. zero

Answer: C



Watch Video Solution

84. Two identical billiard balls undergo an oblique elastic collision. Initially, one of the balls is stationary. If the initially stationary ball after collision moves in a direction which makes an angle of 37° with direction of initial motion of the moving ball, then the angle through which initially moving ball will be deflected is

A. 37°

B. 60°

C. 53°

D. $> 53^\circ$

Answer: C



Watch Video Solution

85. A ball of mass m is attached to a cord of length L , pivoted at point O , as shown in Fig. The ball is released from rest at point A,

swings down and makes an inelastic collision with a block of mass $2m$ kept on a rough horizontal floor. The coefficient of restitution of collision is $e = 2/3$ and coefficient of friction between block and surface is μ . After collision, the ball comes momentarily to rest at C when cord makes an angle of θ with the vertical and block moves a distance of $3L/2$ on rough horizontal floor before stopping. The

values of μ and θ are, respectively,

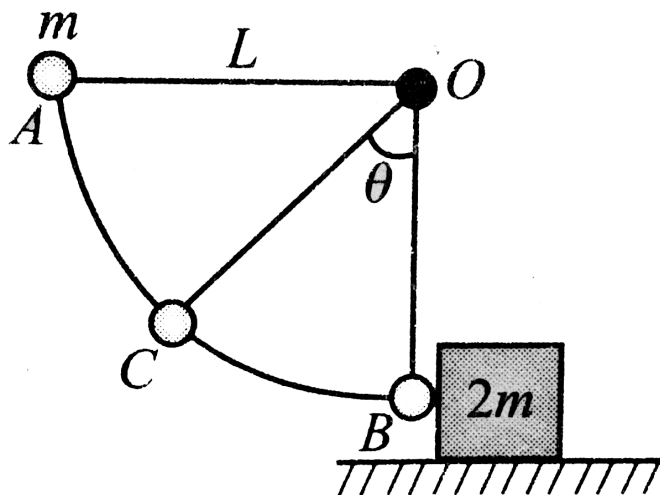

- A. $\frac{50}{243}, \cos^{-1}\left(\frac{80}{81}\right)$
- B. $\frac{50}{81}, \cos^{-1}\left(\frac{80}{81}\right)$
- C. $\frac{2}{81}, \cos^{-1}\left(\frac{80}{243}\right)$
- D. $\frac{2}{243}, \cos^{-1}\left(\frac{80}{243}\right)$

Answer: A



Watch Video Solution

86. A ball of mass m is released from rest relative to elevator at a height h , above the floor of the elevator. After making collision with the floor of the elevator it rebounds to height h_2 . The coefficient of restitution for Collision is e . For this situation, mark the

correct statement(s).

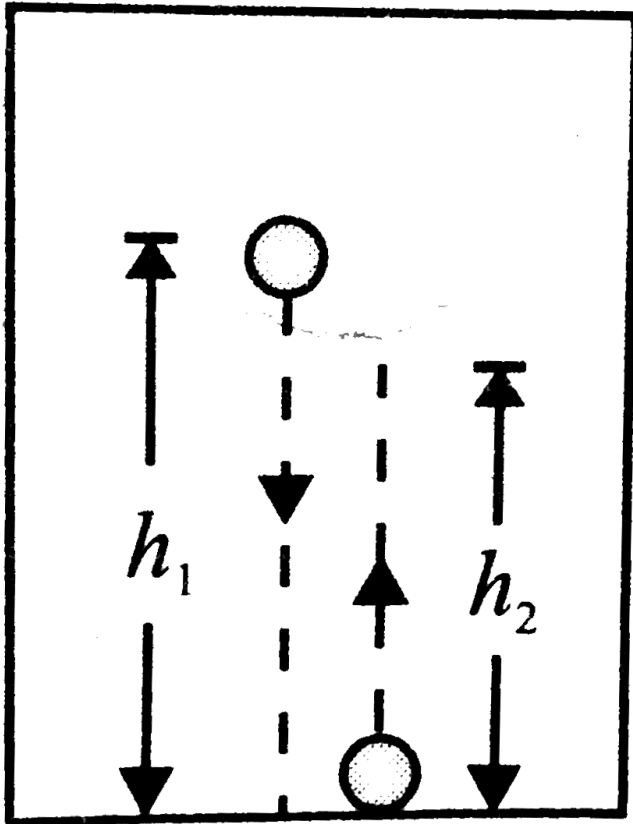

A. If elevator is moving down with constant

velocity v_0 , then $h_2 = e^2 h_1$

B. If elevator is moving down with constant velocity v_0 , then

$$h_2 = e^2 h_1 - \frac{v_0^2}{2g}$$

C. if elevator is moving down with constant velocity v_0 , then impulse imparted by

floor of the elevator of the ball is

$m(\sqrt{2gh_2} + \sqrt{2gh_1} + 2v_0)$ is the

upward direction.

D. If elevator is moving with constant

acceleration of $g/4$ in upward direction,

then it is not possible to determine a relation between h_1 and h_2 from the given information.

Answer: A



Watch Video Solution

87. Two blocks A and B of masses m and $2m$, respectively, are connected with the help of a spring having spring constant, k as shown in Fig. Initially, both the blocks are moving with

same velocity v on a smooth horizontal plane with the spring in its natural length. During their course of motion, block B makes an inelastic collision with block C of mass m which is initially at rest. The coefficient of restitution for the collision is $1/2$. The maximum compression in the spring is

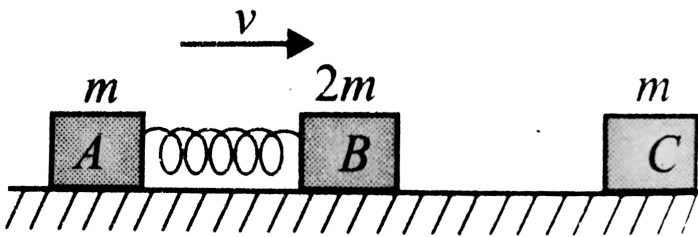

A. $\sqrt{\frac{2m}{k}}$

B. will never be attained

C. $\sqrt{\frac{m}{12k}}v$

D. $\sqrt{\frac{m}{6k}}v$

Answer: D



Watch Video Solution

88. A $3000kg$ space probe is moving in a gravity free space at a constant velocity of $300m/s$. To change the direction of space probe, rockets have been fired in a direction perpendicular to the direction of initial motion

of the space probe, the rocket firing exerts a thrust of $4000N$ for $225s$. The space probe will turn by an angle of (neglect the mass of the rockets fired)

A. 30°

B. 60°

C. 45°

D. 37°

Answer: C



Watch Video Solution

89. After a totally inelastic collision, two objects of the same mass and same initial speeds are found to move together at half of their initial speeds. The angle between the initial velocities of the objects is

A. 30°

B. 60°

C. 45°

D. 37°

Answer: A



Watch Video Solution

90. An object of mass 10kg is launched from the ground at $t = 0$, at an angle of 37° above the horizontal with a speed of 30m/s . At some time after its launch, an explosion splits the projectile into two pieces. One piece of mass 4kg is observed at $(105\text{m}, 43\text{m})$ at $t = 2\text{s}$. Find the location of second piece at

$$t = 2s?$$

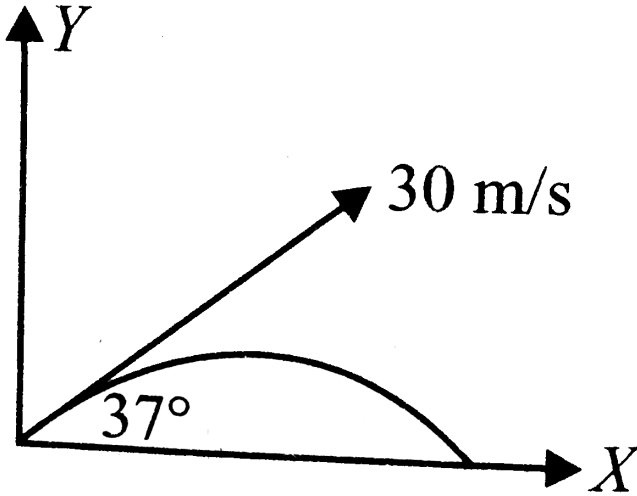

- A. (10, 2)
- B. (48, 16)
- C. (10, - 2)
- D. information insufficient

Answer: D



Watch Video Solution

91. For the system shown in Fig. the string is light and pulley is frictionless. The $4kg$ block is given an upward velocity of $1m/s$. The centre of mass of the two blocks will [neglect the

impulse duration]

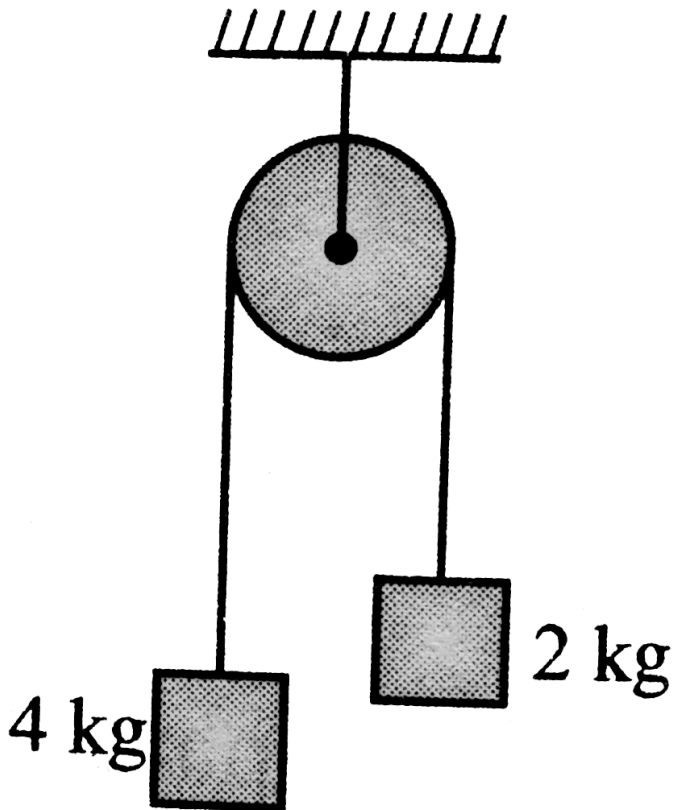

A. accelerate down with $g/3$

B. initially accelerate downwards with g and

then after some time accelerate down

with $g/3$.

C. initially accelerate with g and then the acceleration is 0

D. initially accelerate with g and then with acceleration with $g/9$.

Answer: D



Watch Video Solution

92. A parallel beam of particles each of mass m moving with velocity v impinges on a wall at an angle θ to its normal. The number of particles per unit volume in the beam is n . If the collision of particles with the wall is elastic, then the pressure exerted by this beam on the wall is

A. $2mnv^2 \cos \theta$

B. $2mnv^2 \cos^2 \theta$

C. $2mnv \cos \theta$

D. $2mnv \cos^2 \theta$

Answer: B



Watch Video Solution

93. A block of mass m starts from rest and slides down a frictionless semi-circular track from a height h as shown. When it reaches the lowest point of the track, it collides with a stationary piece of putty also having mass m . If the block and the putty stick together and continue to slide, the maximum height that

the block-putty system could reach is

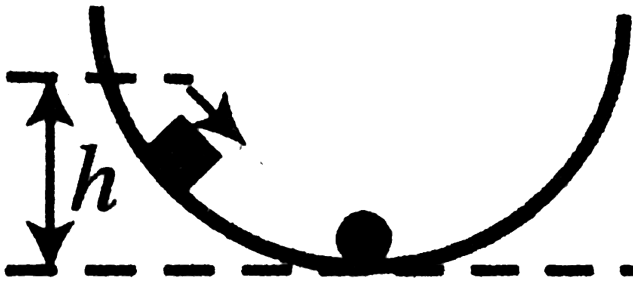

A. $\frac{h}{4}$

B. $\frac{h}{2}$

C. h

D. independent of h

Answer: A



Watch Video Solution

94. Three blocks are initially placed as shown in figure , block A has mass m and initial velocity v to the right . Block B with mass m and block C with mass $4m$ are both initially at rest . Neglect friction . All collisions are elastic . The final velocity of block A is

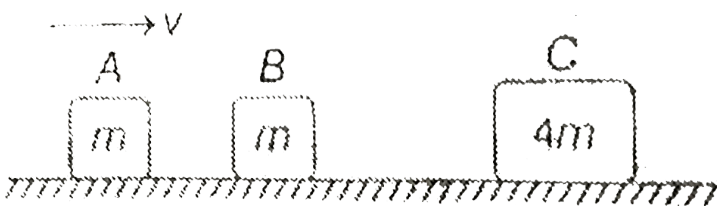

A. $0.6v$ to the left

B. $1.4v$ to the left

C. v to the left

D. $0.4v$ to the right

Answer: A



Watch Video Solution

95. In the figure shown, the two identical balls of mass M and radius R each, are placed in contact with each other on the frictionless horizontal surface. The third ball of mass M

and radius $R/2$, is coming down vertically and has a velocity $= v_0$ when it simultaneously hits the two balls and itself comes to rest. Then, each of the two bigger balls will move after collision with a speed equal to

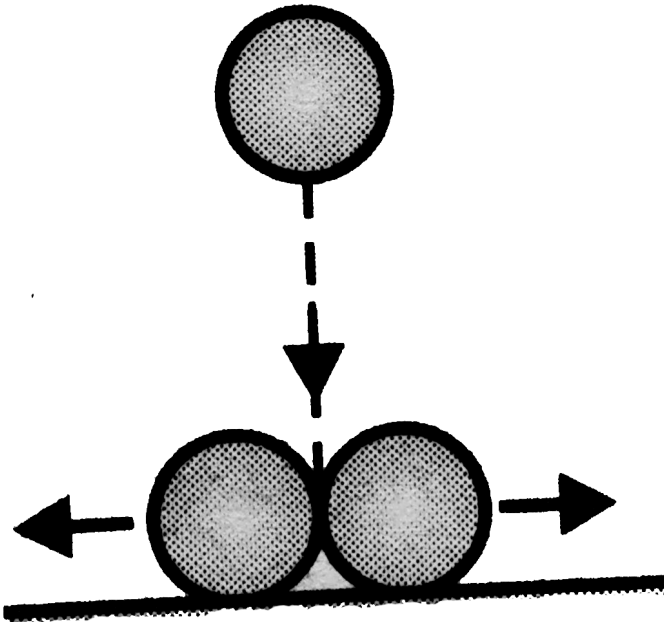

A. $4v_0 / \sqrt{5}$

B. $2v_0 / \sqrt{5}$

C. $v_0 / \sqrt{5}$

D. none of these

Answer: C



Watch Video Solution

96. Three blocks are placed on smooth horizontal surface and lie on same horizontal straight line. Block 1 and block 3 have mass m

each and block 2 has mass M ($M > m$). Block 2 and block 3 are initially stationary, while block 1 is initially moving towards block 2 with speed v as shown. Assume that all collisions are head on and perfectly elastic. What value of M/m ensures that block 1 and block 3 have the same final speed?

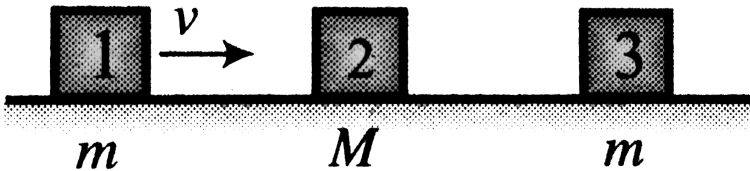

- A. $5 + \sqrt{2}$
- B. $5 - \sqrt{2}$

C. $2 + \sqrt{5}$

D. $3 + \sqrt{5}$

Answer: C



Watch Video Solution

97. A particle of mass m is moving along the x -axis with speed v when it collides with a particle of mass $2m$ initially at rest. After the collision, the first particle has come to rest and the second particle has split into two equal-

mass pieces that are shown in the figure.

Which of the following statements correctly describes the speeds of the two pieces?

$$(\theta > 0)$$

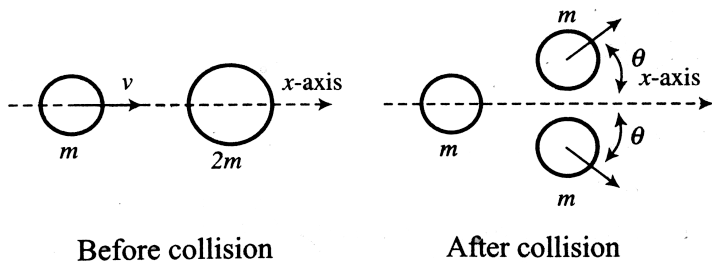

- A. each piece moves with speed v .
- B. each piece moves with speed $v/2$.
- C. one of the pieces moves with speed $v/2$,
the other moves with speed greater than

$v/2$.

D. each piece moves with speed greater than $v/2$.

Answer: D



Watch Video Solution

98. A particle of mass m is acted on by two forces of equal magnitude F maintaining their orientation relative to the velocity v as shown

in Fig. The momentum of the particle

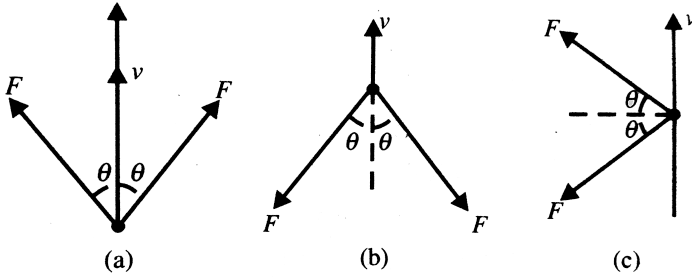

A. increases in a

B. decreases in b

C. only the direction changes in c

D. all are correct

Answer: D



Watch Video Solution

99. Let there are three equal masses situated at the vertices of an equilateral triangle, as shown in Fig. Now particle A starts with a velocity v_1 towards line AB , particle B starts with the velocity v_2 , towards line BC and particle C starts with velocity v_3 towards line CA . Find the displacement of the centre of mass of the three particles A , B and C after

time t . What would it be if $v_1 = v_2 = v_3$?

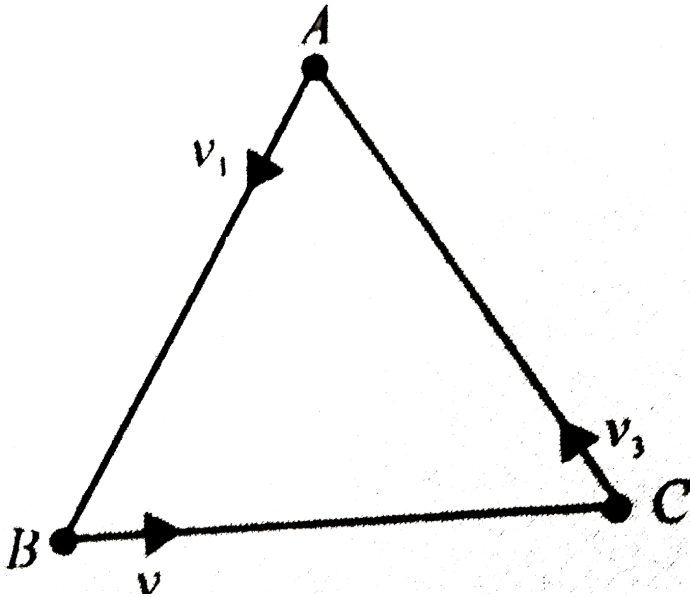

A. zero

B. $\frac{v_1 + v_2 + v_3}{3} t$

C. $\frac{v_1 + \frac{\sqrt{3}}{2} v_2 + \frac{v_3}{2}}{3} t$

D. $\frac{v_1 + v_2 + v_3}{4} t$

Answer: A



Watch Video Solution

100. A ball is projected in a direction inclined to the vertical and bounces on a smooth horizontal plane. The range of one rebound is R . If the coefficient of restitution is e , then range of the next rebound is

A. $R' = eR$

B. $R' = e^2R$

C. $R' = \frac{R}{e}$

D. $R' = R'$

Answer: A



Watch Video Solution

101. In the figure shown, the heavy ball of mass $2m$, rests on the horizontal surface and the lighter ball of mass m is dropped from a height $h > 2l$. At the instant the string gets taut, the upward the velocity of the heavy ball

will be

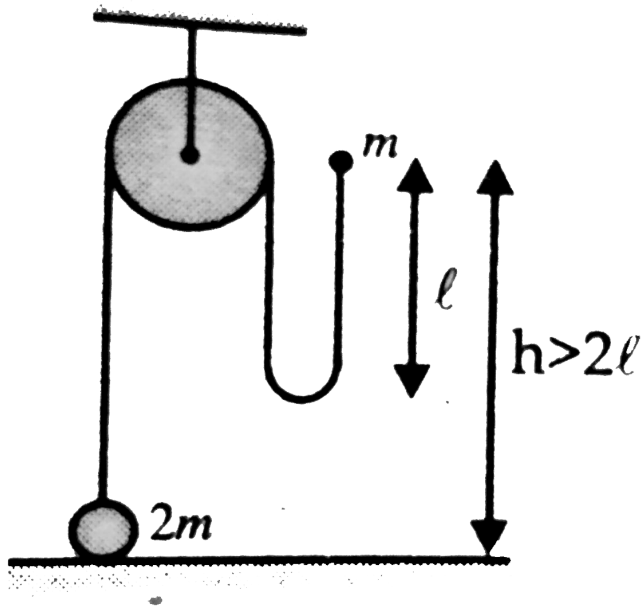

A. $\frac{2}{3} \sqrt{gl}$

B. $\frac{4}{3} \sqrt{gl}$

C. $\frac{1}{3} \sqrt{gl}$

D. $\frac{1}{2} \sqrt{gl}$

Answer: A



Watch Video Solution

102. In the figure shown, the cart of mass $6m$ is initially at rest. A particle of mass m is attached to the end of the light rod which can rotate freely about A . If the rod is released from rest in a horizontal position shown, determine the velocity v_{rel} of the particle with

respect to the cart when the rod is vertical.

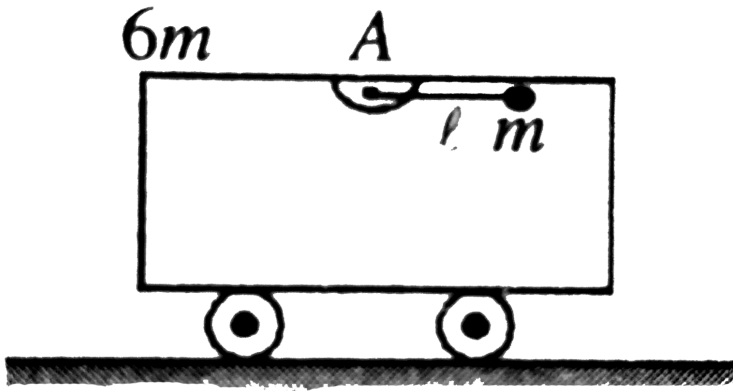

A. $\sqrt{\frac{14}{3}gl}$

B. $\sqrt{\frac{7}{6}gl}$

C. $\sqrt{\frac{7}{3}gl}$

D. $\sqrt{\frac{8}{3}gl}$

Answer: C



Watch Video Solution

103. Two identical particles collide in air inelastically. One moves horizontally and the other moves vertically with equal speed just before collision. The fractional loss in kinetic energy of the system of particles is equal to

A. $\frac{1}{\sqrt{2}}$

B. $\frac{1}{2}$

C. $\frac{\sqrt{3}}{2}$

D. none of these

Answer: B



Watch Video Solution

104. A particle at rest is constrained to move on a smooth horizontal surface. Another identical particle hits the stationary particle with a velocity v at an angle $\theta = 60^\circ$ with horizontal. If the particles move together, the velocity of the combination just after the impact is equal to

A. v

B. $v/2$

C. $\sqrt{3}v/4$

D. $v/4$

Answer: D



Watch Video Solution

105. A stationary body explodes in to four identical fragments such that three of them fly mutually perpendicular to each other, each

with same $KE(E_0)$. The energy of explosion will be

A. $6E_0$

B. $3E_0$

C. $4E_0$

D. $2E_0$

Answer: A



Watch Video Solution

106. Shown in the figure is a system of three particles of mass 1kg , 2kg and 4kg connected by two springs. The acceleration of A , B and C at any instant are 1ms^{-2} , 2ms^{-2} and $1/2\text{ms}^{-2}$ respectively directed as shown in the figure external force acting on the system is

A. 1N

B. 7N

C. 3N

D. none of these

Answer: C



Watch Video Solution

107. A ping-pong ball of mass m is floating in air by a jet of water emerging out of a nozzle. If the water strikes the ping-gong ball with a speed v and just after collision water falls dead, the rate of flow of water in the nozzle is equal to

A. $\frac{2mg}{V}$

B. $\frac{mV}{g}$

C. $\frac{mg}{V}$

D. none of these

Answer: C



Watch Video Solution

108. A body of mass $1kg$, initially at rest, explodes and breaks into three fragments of masses in the ratio $1:1:3$. The two pieces of equal mass fly off perpendicular to each other

with a speed of 30m/s each. What is the velocity of the heavier fragment?

A. $10\sqrt{2}\text{ms}^{-1}$

B. $5\sqrt{3}\text{ms}^{-1}$

C. $10\sqrt{3}\text{ms}^{-1}$

D. $5\sqrt{2}\text{ms}^{-1}$

Answer: D



Watch Video Solution

109. A block m_1 strikes a stationary block m_3 inelastically. Another block m_2 is kept on m_3 . Neglecting the friction between all contacting surfaces, calculate the fractional decrease in KE of the system in collision.

A. $\frac{m_1}{m_1 + m_2 + m_3}$

B. $\frac{m_1}{m_2 + m_3}$

C. $\frac{m_3}{m_1 + m_3}$

D. $\frac{m_2 + m_3}{m_1 + m_2 + m_3}$

Answer: C



Watch Video Solution

110. A ball collides with an inclined plane of inclination θ after falling through a distance h . If it moves horizontally just after the impact , the coefficient of restitution is

A. $\tan \theta$

B. $\tan^2 \theta$

C. $\cot \theta$

D. $\cot^2 \theta$

Answer: B



Watch Video Solution

111. A particle loses 25 % of its energy during collision with another identical particle at rest. the coefficient of restitution will be

A. 0.25

B. $\sqrt{2}$

C. $\frac{1}{\sqrt{2}}$

D. 0.5

Answer: C



Watch Video Solution

112. A body of mass $3kg$ collides elastically with another body at rest and then continues to move in the original direction with one half of its original speed. What is the mass of the target body?

A. $1kg$

B. $1.5kg$

C. $2kg$

D. $5kg$

Answer: A



Watch Video Solution

113. A glass ball collides with a smooth horizontal surface (xz plane) with a velocity $V = ai - bj$. If the coefficient of restitution of collision be e , the velocity of the ball just after the collision will be

A. $\sqrt{e^2 a^2 + b^2}$ at angle $\tan^{-1}\left(\frac{a}{eb}\right)$ to the vertical

B. $\sqrt{a^2 + e^2 b^2}$ at angle $\tan^{-1}\left(\frac{a}{eb}\right)$ to the vertical

C. $\sqrt{a^2 + \frac{b^2}{e^2}}$ at angle $\tan^{-1}\left(\frac{ea}{b}\right)$ to the vertical

D. $\sqrt{\frac{a^2}{e^2} + b^2}$ at angle $\tan^{-1}\left(\frac{a}{eb}\right)$ to the vertical

Answer: B



Watch Video Solution

114. A mass m_1 moves with a great velocity. It strikes another mass m_2 at rest in head-on collision. It comes back along its path with low speed after collision. Then find out whether $m_1 < m_2$ or $m_1 > m_2$.

A. $m_1 > m_2$

B. $m_1 < m_2$

C. $m_1 = m_2$

D. there is no relation between m_1 and m_2

Answer: B



Watch Video Solution

115. A body is hanging from a rigid support. by an inextensible string of length '1' . It is struck inelastically by an identical body of mass m with horizontal velocity $v = \sqrt{2gl}$ the tension in the string increases just after the striking by

A. mg

B. $3mg$

C. $2mg$

D. none of these

Answer: C



Watch Video Solution

116. A steel ball of mass $0.5kg$ is fastened to a cord $20cm$ long and fixed at the far end and is released when the cord is horizontal. At the bottom of its path the ball strikes a $2.5kg$ steel

block initially at rest on a frictionless surface.

The collision is elastic. The speed of the block just after the collision will be.

A. a. $\frac{10}{3} \text{ms}^{-1}$

B. b. $\frac{20}{3} \text{ms}^{-1}$

C. c. 5ms^{-1}

D. d. $\frac{5}{3} \text{ms}^{-1}$

Answer: B



Watch Video Solution

117. A bullet of mass 0.01kg and travelling at a speed of 500ms^{-1} strikes a block of mass 2kg which is suspended by a string of length 5m . The centre of gravity of the block is found to raise a vertical distance of 0.2m . What is the speed of the bullet after it emerges from the block?

A. 15ms^{-1}

B. 20ms^{-1}

C. 100ms^{-1}

D. 50ms^{-1}

Answer: C



Watch Video Solution

118. A bomb of mass $3m$ is kept inside a closed box of mass $3m$ and length $4L$ at its centre. It explodes in two parts of mass m and $2m$. The two parts move in opposite directions and stick to the opposite sides of the walls of box. The box is kept on a smooth horizontal surface. What is the distance moved by the box

during this time interval.

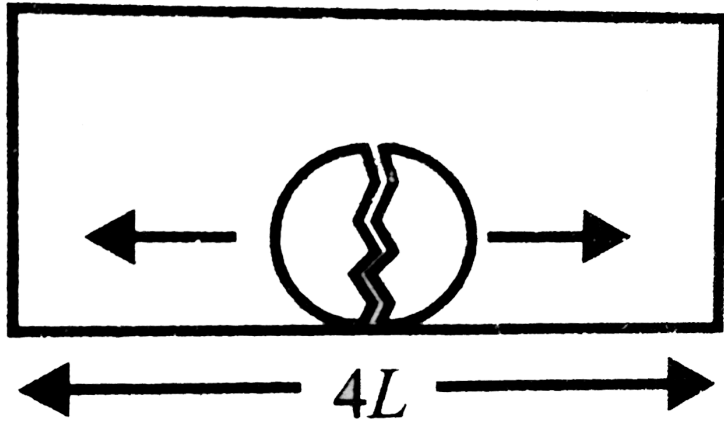

- A. 0
- B. $\frac{L}{6}$
- C. $\frac{L}{12}$
- D. $\frac{L}{3}$

Answer: D



Watch Video Solution

119. For the system shown in the figure, a small block of mass m and smooth irregular shaped block of mass M , both free to move are placed on a smooth horizontal plane. The minimum velocity v imparted to block so that it will overcome the highest point of M is

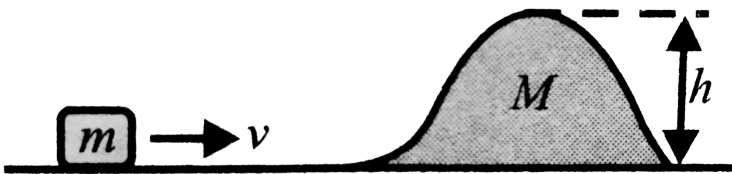

A. $\sqrt{2gh}$

B. $\sqrt{2\left(1 + \frac{m}{M}\right)gh}$

C. $\sqrt{\frac{2m}{M}gh}$

D. $\sqrt{2\left(1 + \frac{M}{m}\right)gh}$

Answer: B



Watch Video Solution

120. Two particles of equal masses moving with same momentum collide perfectly inelastically. After the collision the combined mass moves with half of the speed of the individual masses.

The angle between the initial momenta of individual particle is

A. 60°

B. 90°

C. 120°

D. 45°

Answer: C



Watch Video Solution

121. Two identical carts constrained to move on a straight line, on which sit two twins of same mass, are moving with equal velocity. At some time snow begins to drop uniformly. Ram, sitting on one of the carts, picks the snow from cart and throws off the falling snow sideways and in the second cart Shyam is asleep.

A. Cart carrying Ram will have more speed finally than that carrying Shyam.

B. Cart carrying Ram will have less speed finally than that carrying Shyam.

C. Cart carrying Ram will have same speed finally than that carrying Shyam.

D. depends on the amount of snow thrown.

Answer: D



Watch Video Solution

122. Two particles A and B initially at rest, move towards each other by mutual force of attraction. At the instant when the speed of A is n and the speed of B is $3n$, the speed of the centre of mass of the system is

A. $3n$

B. $2Ns$

C. $1.5n$

D. 0

Answer: C



Watch Video Solution

123. Three point like equal masses m_1 , m_2 and m_3 are connected to the ends of a massless rod of length L which lies at rest on a smooth horizontal plane. At $t = 0$, an explosion occurs between m_2 and m_3 , and as a result, mass m_3 is detached from the rod, and moves with a known velocity v at an angle of 30° with the y -axis. Assume that the masses m_2 and m_3 are unchanged during the explosion. What is the velocity of the centre of mass of the system

consisting of three masses, after the
expulsion?

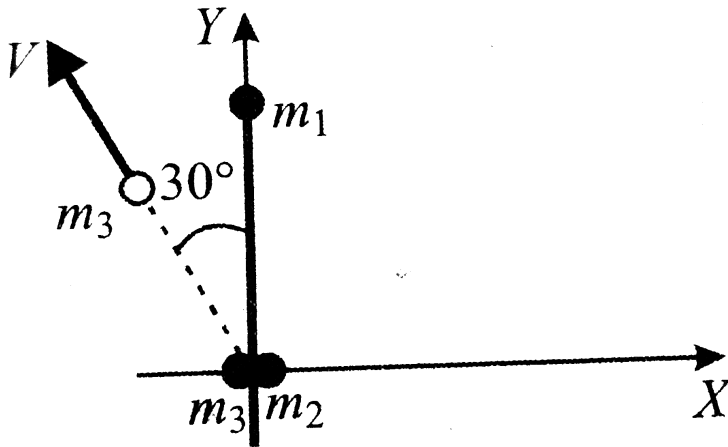

- A. $\frac{v}{4}(\hat{i} - 3\hat{j})$
- B. $\frac{v}{4}(-\hat{i} + \sqrt{3}\hat{j})$
- C. $-v$
- D. none of these

Answer: D



Watch Video Solution

124. A small ball is projected horizontally between two large blocks. The ball is given a velocity $V\text{ms}^{-1}$ and each of the large blocks move uniformly with a velocity of $2V\text{ms}^{-1}$. The ball collides elastically with the blocks. If the velocity of the blocks do not change due to the collision, then find out the velocity of the

ball after the 2nd collision.

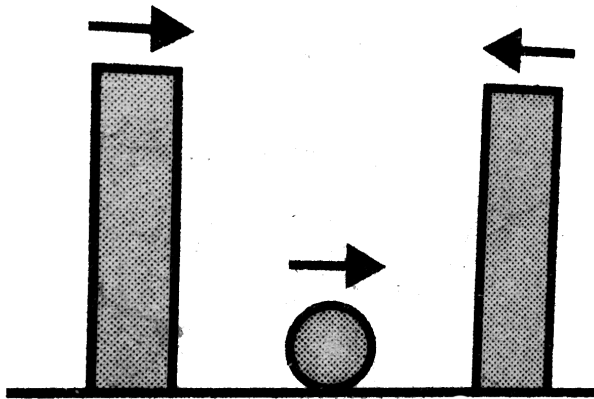

Assume friction to be absent

A. $5v$

B. $7V$

C. $9V$

D. none of these

Answer: C



Watch Video Solution

125. Three particles of masses $1kg$, $2kg$ and $3kg$ are situated at the corners of an equilateral triangle move at speed $6ms^{-1}$, $3ms^{-1}$ and $2ms^{-1}$ respectively. Each particle maintains a direction towards the particles at the next corners symmetrically.

Find velocity of CM of the system at this

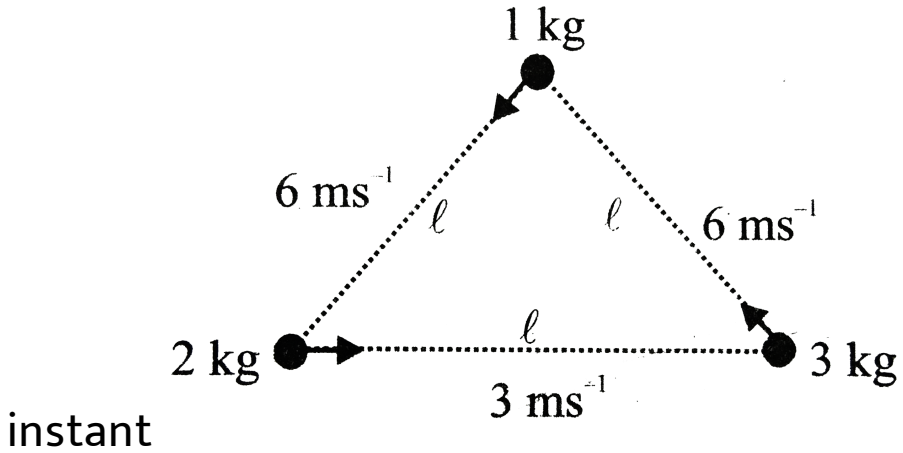

A. $3ms^{-1}$

B. $5ms^{-1}$

C. $6ms^{-1}$

D. zero

Answer: D



126. Three carts move on a frictionless track with masses and velocities as shown. The carts collide and stick together after successive collisions. Find the total magnitude of the impulse experience by *A*.

$$m_1 = 3kg, m_2 = 1kg, m_3 = 2kg$$

$$v_1 = 1m/s, v_2 = 1m/s, v_3 = 2m/s \rightarrow +ve$$

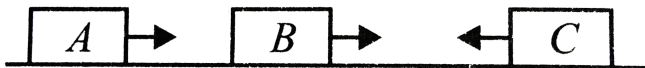

A. $1Ns$

B. $2N_s$

C. $3N_s$

D. $4N_s$

Answer: B



Watch Video Solution

127. Block A is hanging from a vertical spring and is at rest. Block B strikes the block A with velocity v and sticks to it. Then the value of v for which the spring just attains natural length

is

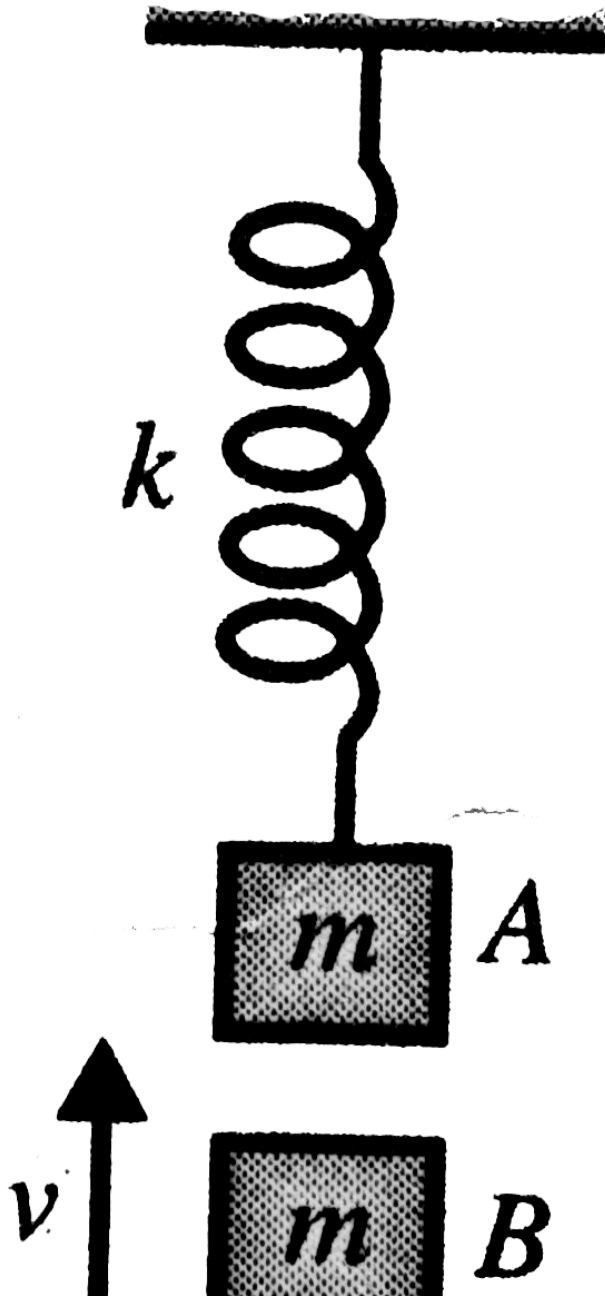

A. $\sqrt{\frac{60mg^2}{k}}$

B. $\sqrt{\frac{6mg^2}{k}}$

C. $\sqrt{\frac{10mg^2}{k}}$

D. none of these

Answer: C



Watch Video Solution

128. A pendulum consists of a wooden bob of mass m and length l . A bullet of mass m_1 is fired towards the pendulum with a speed v_1 . The bullet emerges out of the bob with a speed of $(v_1)/3$ and the bob just completes motion along a vertical circle, then v_1 is

A. $\frac{3m}{2m_1} \sqrt{5gl}$

B. $\frac{m_1}{m} \sqrt{5gl}$

C. $\frac{2m}{3m_1} \sqrt{5gl}$

D. $\frac{m_1}{m} \sqrt{gl}$

Answer: B



Watch Video Solution

129. In the arrangements shown in the figure masses of each ball is 1kg and mass of trolley is 4kg . In the figure, shell of mass 1kg moving horizontally with velocity $v = 6\text{ms}^{-1}$ collides with the ball and get stuck to it then its maximum deflection of the thread (length

1.5m) with vertical

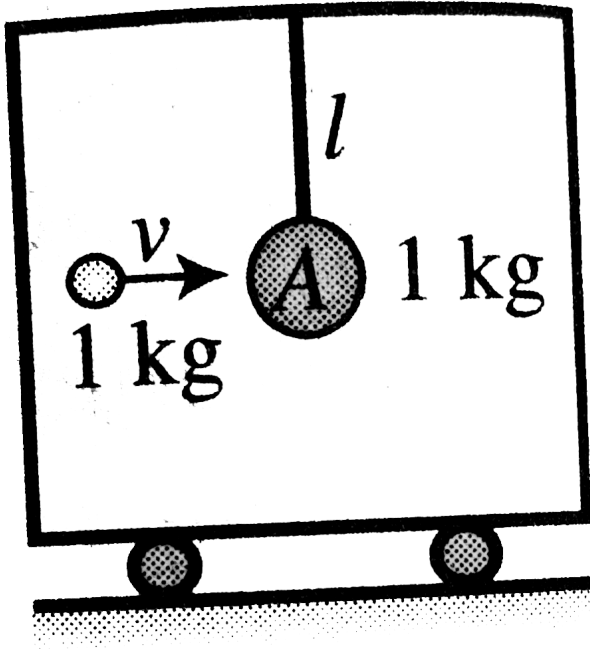

A. 53°

B. 37°

C. 30°

D. 60°

Answer: A



Watch Video Solution

130. A ball of mass 1kg is thrown up with an initial speed of 4m/s . A second ball of mass 2kg is released from rest from some height as

shown in Fig. Choose the correct statement (s).

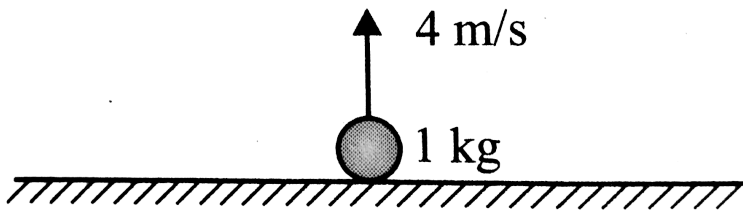
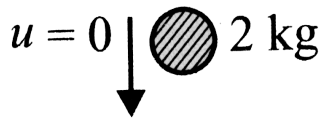

- A. The centre of mass of the two balls comes down with acceleration $g/3$.
- B. The centre of mass first moves up and then comes down.

C. The acceleration of the centre of mass is g downwards.

D. The centre of mass of the two balls remains stationary.

Answer: B



Watch Video Solution

131. Velocity of a particle of mass $2kg$ change

from $\vec{v}_1 = -2\hat{i} - 2\hat{j} \frac{m}{s}$ to

$\vec{v}_2 = (\hat{i} - \hat{j})m/s$ after colliding with a plane surface.

A. The angle made by the plane surface

with the positive x -axis is $\tan^{-1}\left(\frac{1}{3}\right)$

B. The angle made by the plane surface

with the positive x -axis is $\tan^{-1}\left(\frac{1}{3}\right)$

C. The direction of change in momentum

makes an angle $\tan^{-1}\left(\frac{1}{3}\right)$ with the

positive x -axis.

D. The direction of change in momentum

makes an angle $90^\circ + \tan^{-1}\left(\frac{1}{3}\right)$ with

the plane surface.

Answer: A::C::D



Watch Video Solution

132. In an elastic collision between two particles

A. the total kinetic energy of the system is always conserved.

B. the kinetic energy of the system before collision is equal to the kinetic energy of the system after collision.

C. the linear momentum of the system is conserved.

D. the mechanical energy of the system before collision is equal to the

mechanical energy of the system after collision.

Answer: B::C::D



Watch Video Solution

133. A block of mass ' m ' is hanging from a massless spring of spring constant K . It is in equilibrium under the influence of gravitational force. Another particle of same mass ' m ' moving upwards with velocity a_0

hits the block and sticks to it. For the subsequent motion, choose the incorrect

statements:

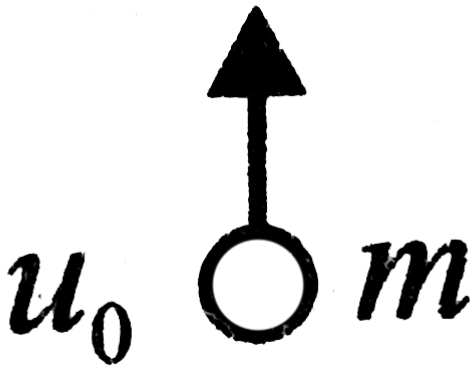
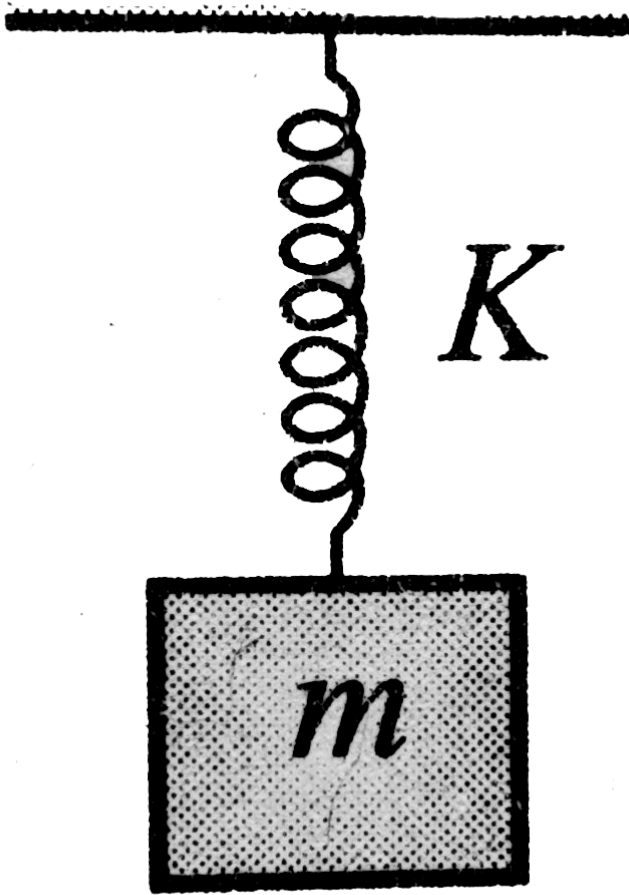

A. Velocity of the combined mass must be maximum at natural length of the spring.

B. Velocity of the combined mass must be maximum at the new equilibrium position.

C. Velocity of the combined mass must be maximum at the instant particle hits the block.

D. Velocity of the combined mass must be maximum at a point lying between old

equilibrium position and natural length.

Answer: A::C::D



Watch Video Solution

134. Which of the following is/are correct?

A. If centre of mass of three particles is at rest and it is known that two of them are moving along different lines, then the third particle must also be moving.

B. If centre of mass remains at rest, then net work done by the forces acting on the system must be zero.

C. If centre of mass remains at rest, then the net external force must be zero.

D. If speed of centre of mass is changing, then there must be some net work being done on the system from outside.

Answer: A::C::D



Watch Video Solution

135. Two masses $2m$ and m are connected by an inextensible light string. The string is passing over a light frictionless pulley. The mass $2m$ is resting on a surface and mass m is hanging in air as shown in Fig. A particle of mass m strikes the mass m from below in case (I) with a velocity v_0 and in case (II) strikes mass m with a velocity v_0 from top and sticks

to it.

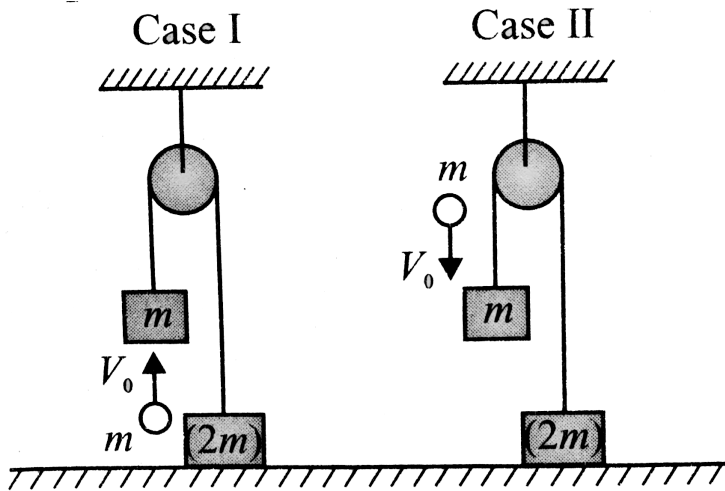

A. The conservation of linear momentum can be applied in both the cases just before and just after collision.

B. The conservation of linear momentum can be applied in case I but cannot be

applied in case II just before and just after collision.

C. The ratio of velocities of mass m just after collision in first and second cases is

$$\frac{1}{2}.$$

D. The ratio of velocities of mass m just after collision in first and second case is

2.

Answer: B::D



Watch Video Solution

136. A ball moving with a velocity v hits a massive wall moving towards the ball with a velocity u . An elastic impact lasts for time Δt

A. The average elastic force acting on the

ball is $[m(u + v)] / \Delta t$

B. The average elastic force acting on the

ball is $[2m(u + v)] / \Delta t$

C. The kinetic energy of the ball increases

by $2mu(u + v)$.

D. The kinetic energy of the ball remains the same after the collision.

Answer: B::C



Watch Video Solution

137. A particle of mass m strikes a horizontal smooth floor with velocity u making an angle θ with the floor and rebound with velocity v making an angle θ with the floor. The

coefficient of restitution between the particle and the floor is e . Then

A. the impulse delivered by the floor to the

$$\text{body is } \mu(1 + e)\sin\theta$$

B. $\tan\phi = e\tan\theta$

C. $v = u\sqrt{1 - (1 - e)^2 \sin^2\theta}$

D. the ratio of final kinetic energy to the

initial kinetic energy is

$$(\cos^2\theta + e^2 \sin^2\theta)$$

Answer: A::B::D



Watch Video Solution

138. A body of mass $2kg$ moving with a velocity $3m/s$ collides with a body of mass $1kg$ moving with a velocity of $4m/s$ in opposite direction. If the collision is head on and completely inelastic, then

A. both particles move together with

$$\text{velocity } \left(\frac{2}{3}\right)m/s$$

B. the momentum of system is $2kgm/s$

throughout

C. the momentum of system is $10kgm/s$

D. the loss of KE of system is $(49/3)J$

Answer: A::B::D



Watch Video Solution

139. Two small rings, each of mass ' m ', are connected to the block of same mass ' m ' through an inextensible massless string of

length ' l '. Rings are constrained to move over smooth rod AB . Initially, the system is held at rest as shown in Fig. Let u and v be the velocities of ring and block, respectively when string makes an angle 60° with the vertical.

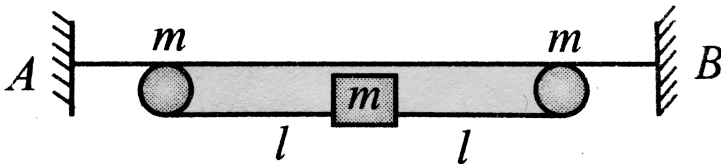

A. $u = \sqrt{\frac{gl}{5}}$

B. $u = \sqrt{\frac{8gl}{5}}$

C. $v = \sqrt{3gl}$

D. $v = \sqrt{\frac{3gl}{5}}$

Answer: A::D



Watch Video Solution

140. A body moving towards a body of finite mass collides with it. It is possible that

- A. both bodies come to rest
- B. both bodies move after collision
- C. the moving body stops and the body moving must have same mass

D. the stationary body remains stationary
and the moving body rebounds

Answer: B::C



Watch Video Solution

141. A ball strikes a wall with a velocity \vec{u} at an angle θ with the normal to the wall surface. and rebounds from it at an angle β with the surface. Then

A. $(\theta + \beta) < 90^\circ$ if the wall is smooth

B. if the wall is rough , coefficient of

$$\text{restitution} = \tan \beta / \cos \theta$$

C. if the wall is rough, coefficient of

restitution

$$< \tan \beta / \cot \theta$$

D. none of these

Answer: A::C::D



Watch Video Solution

Multiple Correct

1. A ball strikes a smooth horizontal floor obliquely and rebounds inelastically.

A. The kinetic energy of the ball just after hitting the floor is equal to the potential energy of the ball at its maximum height after rebound.

B. Total energy of the ball is not conserved.

C. The angle of rebound with the vertical is greater than the angle of incidence.

D. None of the above.

Answer: B::C



Watch Video Solution

2. Choose the correct statements from the following

A. The general form of Newton's second law

of motion is $\vec{F}_{ext} = \vec{m}a$

B. A body can have energy and get no momentum.

C. A body having momentum must necessarily have kinetic energy.

D. The relative velocity of two bodies in a head-on elastic collision remains unchanged in magnitude and direction.

Answer: B::C



Watch Video Solution

3. An ideal spring is permanently connected between two blocks of masses M and m . The blocks-spring system can move over a smooth horizontal table along a straight line along the length of the spring as shown in Fig. The blocks are brought nearer to compress the spring and then released. In the subsequent motion,

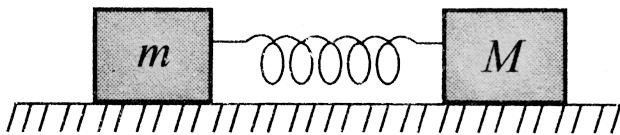

- A. initially they move in opposite directions
with velocities inversely proportional to
their masses
- B. the ratio of their velocities remains
constant
- C. linear momentum and energy of the
system remain conserved
- D. the two blocks will Oscillate about their
centre of mass which remains stationary

Answer: A::B::C::D



Watch Video Solution

4. A steel ball of mass $2m$ suffers one-dimensional elastic collision with a row of three steel balls, each of mass m . If mass $2m$ has collided with velocity v and the three balls numbered 1, 2, 3 were initially at rest, then after the collision

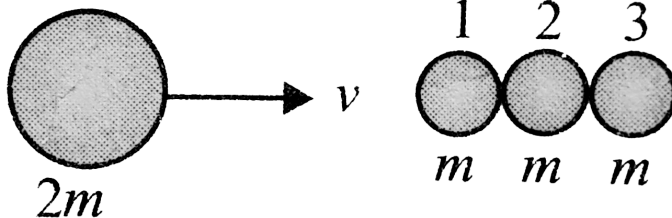

- A. balls 1, 2 and 3 would start moving to the right, each with velocity $v/3$
- B. balls 2 and 3 would start moving to the right, each with velocity $v/2$
- C. balls 2 and 3 start moving to the right, each with velocity v
- D. ball 2 and ball of mass $2m$ would remain at rest

Answer: C::D



Watch Video Solution

5. A man standing on the edge of the terrace of a high rise building throws a stone, vertically up with at speed of 20m/s . Two seconds later, an identical stone is thrown vertically downwards with the same speed of 20m/s . Then

A. the relative velocity between the two stones remain, constant till one hits the ground

- B. both will have the same kinetic energy,
when they hit the ground
- C. the time interval between their hitting
the ground is $2s$
- D. if the collision on the ground is perfectly
elastic, both will rise to the same height
above the ground

Answer: A::B::C::D



Watch Video Solution

6. A block of mass m moving with a velocity v_0 collides with a stationary block of mass M at the back of which a spring of spring constant k is attached, as shown in the figure. Select the correct alternative (s).

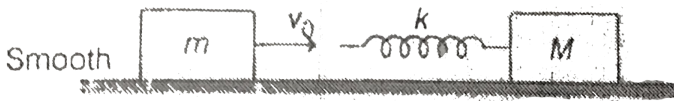

A. The velocity of the centre of mass is v_0

B. The initial kinetic energy of the system in the centre of mass frame is

$$\frac{1}{4} \left(\frac{mM}{M+m} \right) v_0^2$$

C. The maximum compression in the spring

$$\text{is } v_0 \sqrt{\left(\frac{mM}{m+M} \frac{1}{k} \right)}$$

D. When the spring is in the state of maximum compression, the kinetic energy in the centre of mass frame is zero

Answer: C::D



Watch Video Solution

7. Two particles of masses m_1 and m_2 and velocities u_1 and αu_1 ($\alpha \neq 0$) make an elastic head on collision. If the initial kinetic energies of the two particles are equal and m_1 comes to rest after collision, then

A. $\frac{u_1}{u_2} = \sqrt{2} + 1$

B. $\frac{u_1}{u_2} = \sqrt{2} - 1$

C. $\frac{m_2}{m_1} = 3 + 2\sqrt{2}$

D. $\frac{m_2}{m_1} = 3 - 2\sqrt{2}$

Answer: A::C::D



Watch Video Solution

8. A pendulum bob of mass m connected to the end of material string of length l is released from rest from horizontal position as shown in the figure. At the lowest point the bob makes an elastic collision with a stationary block of mass $5m$, which is kept on a frictionless surface. Choose out the correct statement(s) for the instant just after the

impact.

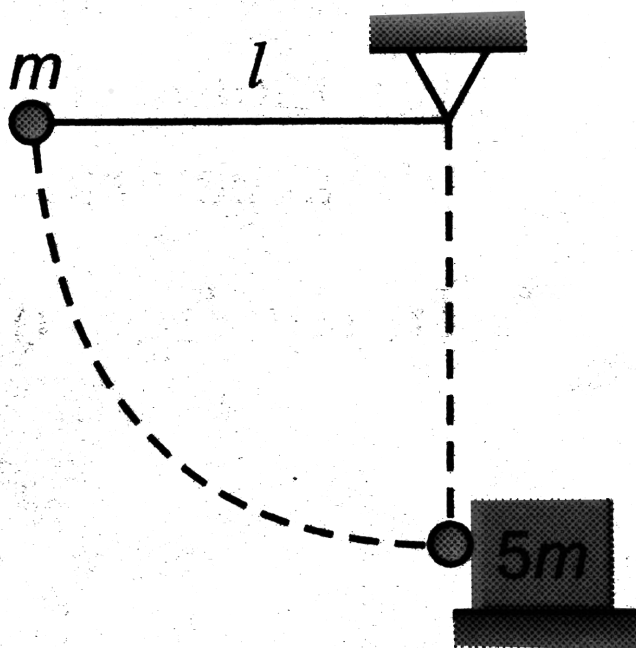

A. Tension in the string is $(17/9)mg$

B. tension in the string is $3mg$

C. the velocity of the block is $\sqrt{2gl}/3$

D. The maximum height attained by the pendulum bob after impact is (measured from the lowest position) $4l/9$.

Answer: A::D



Watch Video Solution

9. A string of length $3l$ is connected to a fixed cylinder whose top view is shown in Fig. The string is initially slack. The other end of the string (connected to a marble) is moving at a

constant velocity of 10 m/s as shown. The string will get stretched at some instant and impulsive tension occurs in the string. If hinge is exerting a force of 40000 N for 0.25 m/s on the cylinder to bear up the impact of impulsive tension, then mark the correct statements. (Take string to be light, breaking tension of the string is $2 \times 10^5\text{ N}$)

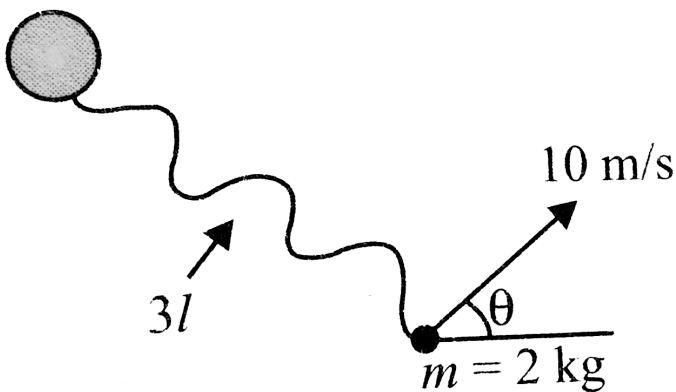

A. The angle made by the velocity of marble with the length of string when it is just stretched is 60°

B. The marble will move in a circular path of varying radius with constant speed of $5\sqrt{3}m / s.$, after the string is taut.

C. To answer above two options, the volume of θ must be given.

D. The string will break if impulse duration is less than $0.05 \text{ min} .$

Answer: A::B::D



Watch Video Solution

10. In the figure, the block B of mass m starts from rest at the top of a wedge W of mass M . All surfaces are without friction. W can slide on the ground. B slides down onto the ground, moves along it with a speed v , has an elastic collision with the wall, and climbs back

on to W .

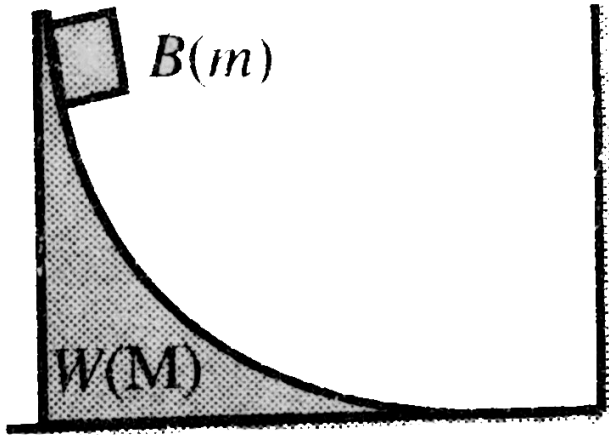

A. From the beginning, till the collision with the wall, the centre of mass of ' B plus W ' does not move horizontally.

B. After the collision, the centre of mass of B plus W moves with the velocity $\frac{2mv}{m + M}$

C. When B reaches its highest position of

$$W, \text{ the speed of } W \text{ is } \frac{2mv}{m + M}$$

D. When B reaches its highest position of

$$W, \text{ the speed of } W \text{ is } \frac{mv}{m + M}$$

Answer: A::B::C::D



Watch Video Solution

11. Two blocks A and B of masses m and $2m$ respectively placed on a smooth floor are connected by a spring. A third body C of mass

m moves with velocity v_0 along the line joining A and B and collides elastically with A . At a certain instant of time after collision it is found that the instantaneous velocities of A and B are same then:

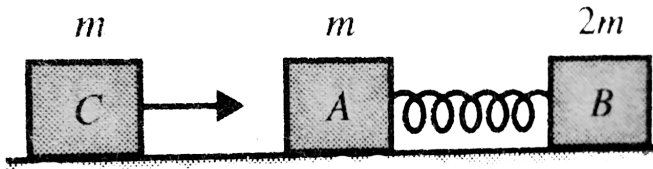

A. the common velocity of A and B at time

t_0 is $v/3$

B. the spring constant is $k = \frac{mv_0^2}{2x_0^2}$

C. the spring constant is $k = \frac{2mv_0^2}{3x_0^2}$

D. none of these

Answer: A::C::D



Watch Video Solution

12. Figure shows two identical blocks each of mass m kept on a smooth floor. Block A is connected to front wall with a just taut straight string and block B is connected to rear wall with a relaxed spring. Assume that the floor of the train car is smooth and exerts

no horizontal forces on the blocks. Mark the correct statement(s).

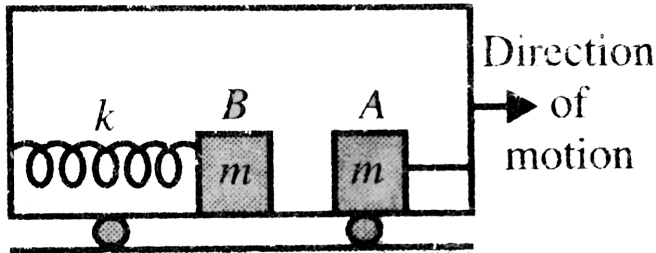

A. When train moves with constant velocity

there is no force either in string or spring.

B. Immediately after the train speeds up

string gets taut and spring is

compressed such that force exerted by each on respective blocks is same.

C. When train slows down block A moves towards front wall.

D. When train slows down resultant force on block A is non zero in ground frame.

Answer: A::C::D



Watch Video Solution

13. A ball of mass 1kg is dropped from a height of 3.2m on smooth inclined plane. The coefficient of restitution for the collision is $e = 1/2$. The ball's velocity become horizontal

after the collision.

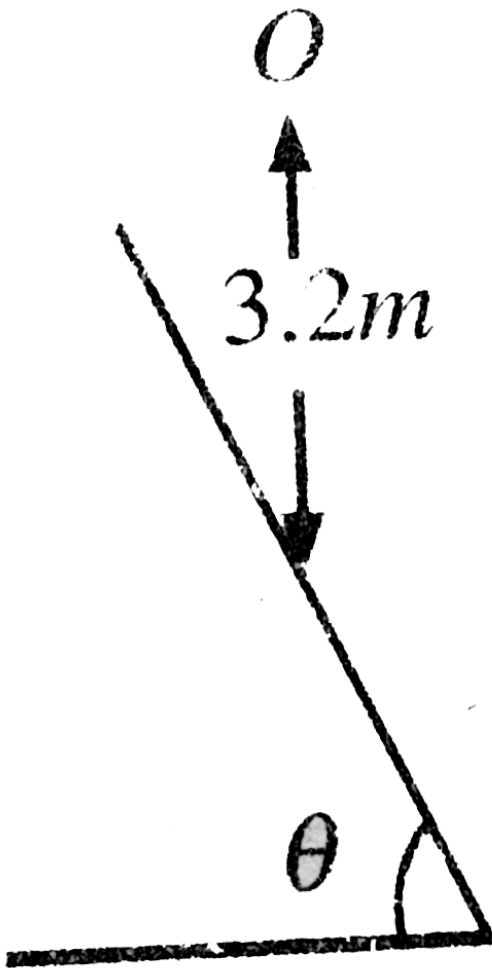

A. the angle $\theta = \tan^{-1} \left(\frac{1}{\sqrt{2}} \right)$

B. The speed of the ball after the collision

$$= 4\sqrt{2}ms^{-1}$$

C. The total loss in kinetic energy during

the collision is $8J$.

D. The ball hits the inclined plane again

while travelling vertically downward.

Answer: A::B



Watch Video Solution

14. A particle of mass m collides with another stationary particle of mass M such that the second particle starts moving and the first particle stops just after the collision. Then which of the following conditions must always be valid ?

A. $\frac{m}{M} \leq 1$

B. $\frac{m}{M} = 1$

C. $e = 1$

D. $e \leq 1$

Answer: A::D



Watch Video Solution

15. Consider two skaters A and B initially at rest on ice (friction is negligible) with A holding a ball. A has greater mass than B and the ball has some significant mass. A throws the ball to B . B catches it and throws it back to A who catches it again. The magnitudes of the skater's (excluding ball) final velocities, A momentum and kinetic energies (denoted

below as v , p and K respectively) are related

as

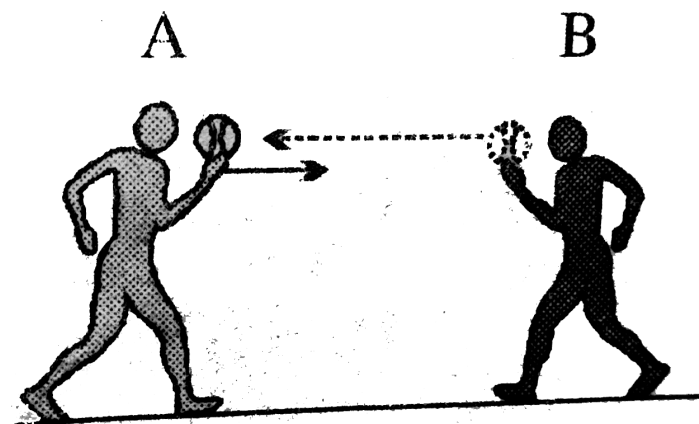

A. $v_A = v_0$

B. $v_A < v_B, p_A < p_B$

C. $p_A = p_B, K_A < K_B$

D. $p_A < p_B, K_A < K_B$

Answer: B::D



Watch Video Solution

16. A man is standing on a plank which is placed on smooth horizontal surface. There is sufficient friction between feet of man and plank. Now man starts running over plank,

correct statement is/are



A. Work done by friction on man with respect to ground is negative.

B. Work done by friction on man with respect to ground is positive

C. Work done by friction on plank with respect to ground

D. Work done by friction on man with respect to plank is zero.

Answer: A::C::D



Watch Video Solution

17. Two particles of equal mass in are projected from the ground with speeds v_1 and v_2 at angles θ_1 , and θ_2 as shown in the figure. Given

$\theta_2 > \theta_1$ and $v_1 \cos \theta_1 = v_2 \cos \theta_2$ Which

statement/s is/are correct?

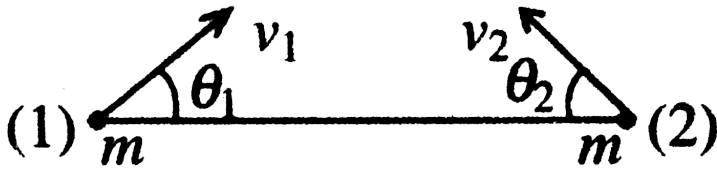

A. Centre of mass of particles will move along a vertical line.

B. Centre of mass of particles will move along a line inclined at some angle with vertical.

C. Particle '1' will be above vertical. centre of mass level when both particles are in air.

D. Particle '2' will be above centre of mass level both particles are in air.

Answer: A::D



Watch Video Solution

18. A particle A suffers an oblique elastic collision with particle B that is at rest initially. If their masses are the same, then after the collision

A. their KE may be equal

B. A continues to move in the original direction while B remains at rest

C. they will move in mutually perpendicular directions

D. A comes to rest and B starts rections
moving in the direction of the original
motion of A_2

Answer: A::C::D



Watch Video Solution

19. Suppose two particles 1 and 2 are projected in vertical plane simultaneously.

Their angles of projection are 30° and θ , respectively, with the horizontal. Let they

collide after a time t in air. Then

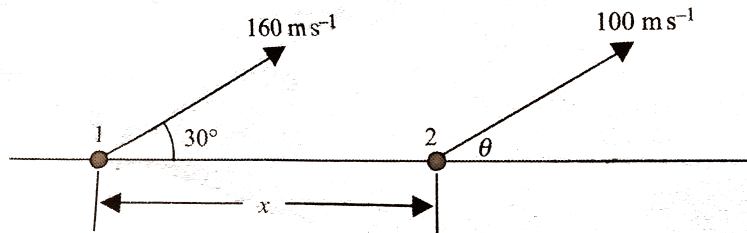

A. $\theta = \sin^{-1}\left(\frac{4}{5}\right)$ and they will have same speed just before the collision

B. $\theta = \sin^{-1}\left(\frac{4}{5}\right)$ and they will have different speed just before the collision

C. $x < 1280\sqrt{3} - 960m$

D. It is possible that the particles collide when both of them are at their highest

point

Answer: B::C::D



Watch Video Solution

20. A particle of mass $m_1 = 4kg$ moving at $6\hat{i}ms^{-1}$ collides perfectly elastically with a particle of mass $m_2 = 2$ moving at $3\hat{i}ms^{-1}$

A. Velocity of centre of mass (CM) is

$$5\hat{i}ms^{-1}$$

B. The velocities of the particles relative to the centre of mass have same magnitude.

C. Speed of individual particle before and after collision remains same.

D. The velocity of particles relative to CM after collision are

$$\vec{v}_{1f/cm} = -\hat{i}ms^{-1}, \vec{v}_{2f/cm} = 2\hat{i}ms^{-1}$$

Answer: A::D



Watch Video Solution

21. Consider a block of mass 10kg , which rests on a smooth surface and is subjected to a horizontal force of 6N . If observer A is in a fixed frame x .

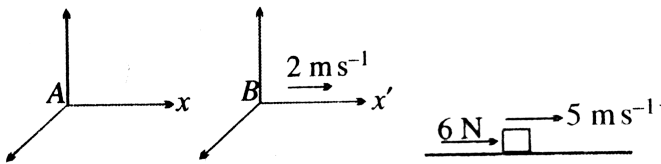

A. The final speed of the block in 4s is 7.4 m s^{-1} , if it has initial speed of 5 m s^{-1} measured from fixed frame.

B. Same speed will be observed by an observer B , attached to the x' axis that moves at a constant velocity of $2ms^{-1}$ relative to A

C. Principle of impulse and momentum is valid for observers in any inertial reference frame

D. Momentum of a body is reference frame dependent.

Answer: A::C::D



Watch Video Solution

22. Statement I. A particle strikes head-on with another stationary particle such that the first particle comes to rest after collision. The collision should necessarily be elastic.

Statement II: In elastic collision, there is no loss of momentum of the system of the particles.

A. Both assertion and reason are true and reason is the correct explanation of

assertion.

B. Both assertion and reason are true but reason is not the correct explanation of assertion.

C. Assertion is true and reason is false.

D. Assertion is false and reason is true.

Answer: D



Watch Video Solution

23. Statement I: No external force acts on a system of two spheres which undergo a perfectly elastic head-on collision. The minimum kinetic energy of this system is zero if the net momentum of the system is zero.

Statement II: If any two bodies undergo a perfectly elastic head-on collision, at the instant of maximum deformation, the complete kinetic energy of the system is converted to' deformation potential energy of the system.

A. Both assertion and reason are true and reason is the correct explanation of assertion.

B. Both assertion and reason are true but reason is not the correct explanation of assertion.

C. Assertion is true and reason is false.

D. Assertion is false and reason is true.

Answer: C



Watch Video Solution

24. Statement I: If a sphere of mass m moving with speed u undergoes a perfectly elastic head-on collision with another sphere of heavier mass M at rest ($M > m$), then direction of velocity of sphere of mass m is reversed due to collision (no external force acts on system of two spheres).

Statement II: During a collision of spheres of unequal masses, the heavier mass exerts more force on the lighter mass in comparison to the

force which lighter mass exerts on the heavier one,

A. Both assertion and reason are true and reason is the correct explanation of assertion.

B. Both assertion and reason are true but reason is not the correct explanation of assertion.

C. Assertion is true and reason is false.

D. Assertion is false and reason is true.

Answer: C



Watch Video Solution

25. Statement I: If a ball projected up obliquely from the ground breaks up into several fragments in its path, the centre of the system of all fragments moves in the same parabolic path compared to initial one till all fragments are in air.

Statement II: In the situation of Statement 1, at the instant of breaking, the fragments may be

thrown in different directions with different speeds.

A. Both assertion and reason are true and reason is the correct explanation of assertion.

B. Both assertion and reason are true but reason is not the correct explanation of assertion.

C. Assertion is true and reason is false.

D. Assertion is false and reason is true.

Answer: B



Watch Video Solution

Assertion - Reasoning

1. Statement I: In a two-body collision, the momenta of the particles are equal and opposite to one another, before as well as after the collision when measured in the centre of mass frame.

Statement. II: The momentum of the system is zero from the centre of mass frame.

A. Both assertion and reason are true and reason is the correct explanation of assertion.

B. Both assertion and reason are true but reason is not the correct explanation of assertion.

C. Assertion is true and reason is false.

D. Assertion is false and reason is true.

Answer: A



Watch Video Solution

2. Three spheres, each of mass m , can slide freely on a frictionless, horizontal surface. Spheres A and B are attached to an inextensible, inelastic cord of length l and are at rest in the position shown where sphere B is struck by sphere C which is moving to the right with a velocity v_0 . Knowing that the cord is taut where sphere B is struck by sphere C

and assuming 'head on' inelastic impact between B and C , we cannot conserve kinetic energy of the entire system.

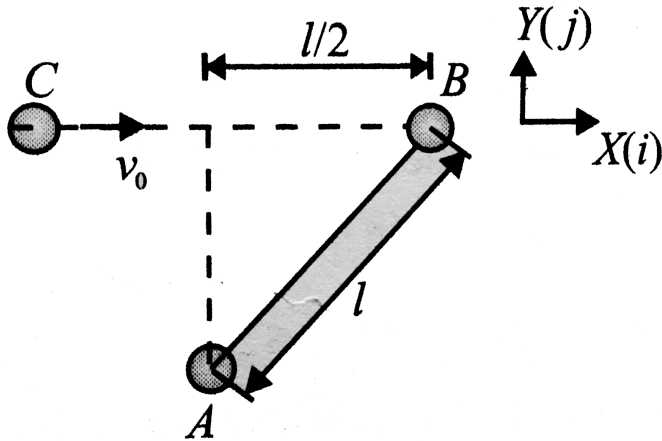

The velocity of B immediately after collision is along unit vector

A. \hat{i}

B. $\frac{\hat{i} + \hat{j}}{\sqrt{2}}$

C. $\frac{\sqrt{3}}{2} \hat{i} + \frac{1}{2} \hat{j}$

D. none of these

Answer: D



Watch Video Solution

Linked Comprehension

1. Three spheres, each of mass m , can slide freely on a frictionless, horizontal surface. Spheres A and B are attached to an

inextensible, inelastic cord of length l and are at rest in the position shown where sphere B is struck by sphere C which is moving to the right with a velocity v_0 . Knowing that the cord is taut where sphere B is struck by sphere C and assuming 'head on' inelastic impact between B and C , we cannot conserve kinetic energy of the entire system.

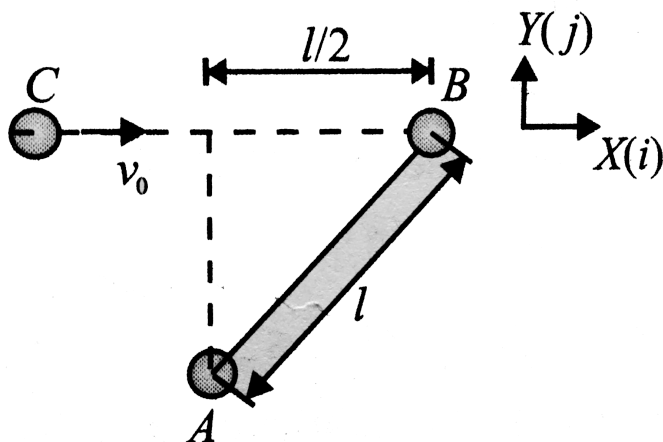

The magnitude of velocity of A immediately after collision is

A. \hat{j}

B. $\frac{1}{2}\hat{i} + \frac{\sqrt{3}}{2}\hat{j}$

C. \hat{j}

D. none of these

Answer: B



Watch Video Solution

2. Three spheres, each of mass m , can slide freely on a frictionless, horizontal surface. Spheres A and B are attached to an inextensible, inelastic cord of length l and are at rest in the position shown where sphere B is struck by sphere C which is moving to the right with a velocity v_0 . Knowing that the cord is taut where sphere B is struck by sphere C and assuming 'head on' inelastic impact between B and C , we cannot conserve kinetic energy of the entire system.

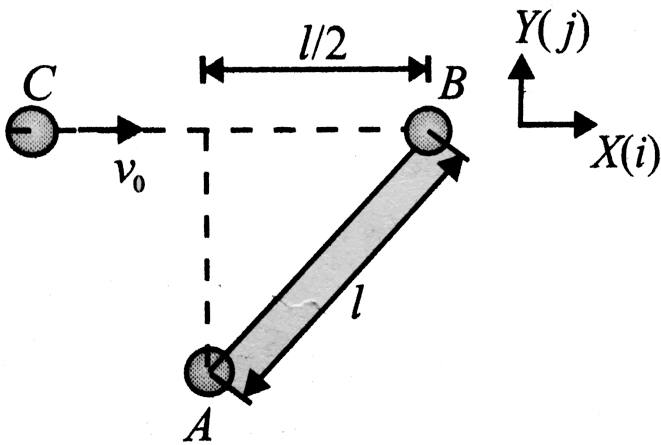

If velocity of C immediately after collision becomes $\frac{v_0}{2}$ in the initial direction of motion, the impulse due to string on sphere A is

A. $\frac{mv_0}{8}$

B. $\frac{mv_0}{2}$

C. $\sqrt{\frac{mv_0}{4}}$

D. none of these

Answer: A



Watch Video Solution

3. Three spheres, each of mass m , can slide freely on a frictionless, horizontal surface. Spheres A and B are attached to an inextensible, inelastic cord of length l and are at rest in the position shown where sphere B is struck by sphere C which is moving to the right with a velocity v_0 . Knowing that the cord is taut where sphere B is struck by sphere C

and assuming 'head on' inelastic impact between B and C , we cannot conserve kinetic energy of the entire system.

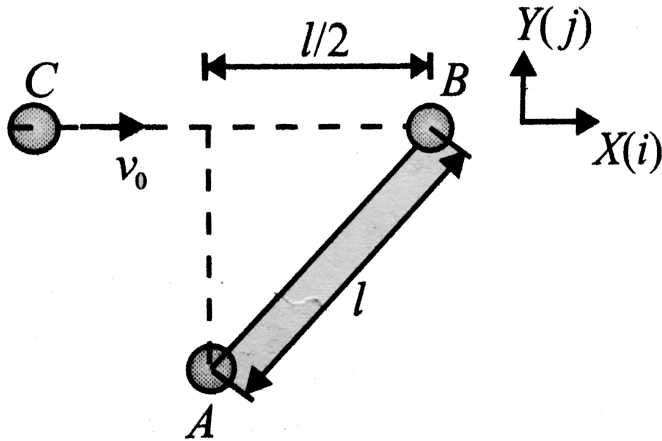

The magnitude of velocity of A immediately after collision is

A. $\frac{\sqrt{3v_0}}{4}$

B. $\frac{v_0}{8}$

C. $\frac{v_0}{4}$

D. $\frac{\sqrt{mv_0}}{8}$

Answer: B



Watch Video Solution

4. Three spheres, each of mass m , can slide freely on a frictionless, horizontal surface. Spheres A and B are attached to an inextensible, inelastic cord of length l and are at rest in the position shown where sphere B

is struck by sphere C which is moving to the right with a velocity v_0 . Knowing that the cord is taut where sphere B is struck by sphere C and assuming 'head on' inelastic impact between B and C , we cannot conserve kinetic energy of the entire system.

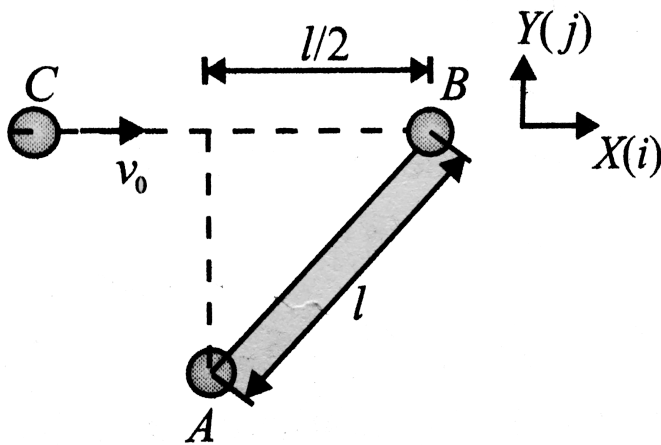

The

velocity of B immediately after collision is along unit vector

A. $(17mv_0^2)$

B. $\frac{15mv_0^2}{64}$

C. $\frac{212mv_0^2}{25}$

D. none of these

Answer: A



Watch Video Solution

5. Collision is a physical process in which two or more objects, either particle masses or rigid bodies, experience very high force of

interaction for a very small duration. It is not essential for the objects to physically touch each other for collision to occur. Irrespective of the nature of interactive force and the nature of colliding bodies, Newton's second law holds good on the system. Hence, momentum of the system before and after the collision remains conserved if no appreciable external force acts on the system during collision.

The amount of energy loss during collision, if at all, is indeed dependent on the nature of colliding objects. The energy loss is observed to be maximum when objects stick together

after collision. The terminology is to define collision as 'elastic' if no energy loss takes place and to define collision as 'plastic' for maximum energy loss. The behaviour of system after collision depends on the position of colliding objects as well. A unidirectional motion of colliding objects before collision can turn into two dimensional after collision if the line joining the centre of mass of the two colliding objects is not parallel to the direction of velocity of each particle before collision. Such type of collision is referred to as oblique collision which may be either two or three

dimensional.

According to the definition of collision in paragraph 1, which of the following physical process is not a collision?

A. A projectile exploding into three fragments at its highest point.

B. Two soap bubbles coalescing to form a bubble of larger radius.

C. A vertically upward thrown particle changing direction at its highest point.

D. A piece of magnet thrown on a metallic surface.

Answer: C



Watch Video Solution

6. Collision is a physical process in which two or more objects, either particle masses or rigid bodies, experience very high force of interaction for a very small duration. It is not essential for the objects to physically touch

each other for collision to occur. Irrespective of the nature of interactive force and the nature of colliding bodies, Newton's second law holds good on the system. Hence, momentum of the system before and after the collision remains conserved if no appreciable external force acts on the system during collision.

The amount of energy loss during collision, if at all, is indeed dependent on the nature of colliding objects. The energy loss is observed to be maximum when objects stick together after collision. The terminology is to define collision as 'elastic' if no energy loss takes

place and to define collision as 'plastic' for maximum energy loss. The behaviour of system after collision depends on the position of colliding objects as well. A unidirectional motion of colliding objects before collision can turn into two dimensional after collision if the line joining the centre of mass of the two colliding objects is not parallel to the direction of velocity of each particle before collision. Such type of collision is referred to as oblique collision which may be either two or three dimensional.

Which of the following collisions is one-dimensional?

A. A ball striking a rigid wall (consider ball as system)

B. A 5kg mass thrown vertically up exploding during its motion (5kg mass is the system).

C. A particle hitting a rigid bar of length L lying on a frictionless surface (consider rigid bar as the system).

D. Two particles moving towards each other due to gravitational attraction and hitting each other (consider all particles as system).

Answer: B



Watch Video Solution

7. Collision is a physical process in which two or more objects, either particle masses or rigid bodies, experience very high force of

interaction for a very small duration. It is not essential for the objects to physically touch each other for collision to occur. Irrespective of the nature of interactive force and the nature of colliding bodies, Newton's second law holds good on the system. Hence, momentum of the system before and after the collision remains conserved if no appreciable external force acts on the system during collision.

The amount of energy loss during collision, if at all, is indeed dependent on the nature of colliding objects. The energy loss is observed to be maximum when objects stick together

after collision. The terminology is to define collision as 'elastic' if no energy loss takes place and to define collision as 'plastic' for maximum energy loss. The behaviour of system after collision depends on the position of colliding objects as well. A unidirectional motion of colliding objects before collision can turn into two dimensional after collision if the line joining the centre of mass of the two colliding objects is not parallel to the direction of velocity of each particle before collision. Such type of collision is referred to as oblique collision which may be either two or three

dimensional.

According to the definition of oblique collision in the paragraph, which of the following collisions cannot be oblique'?

A. Collision between two point masses.

B. Collision between two rings of same radius.

C. Collision between two rings of different radius.

D. Collision between a particle and a ring of finite radius.

Answer: A



Watch Video Solution

8. Collision is a physical process in which two or more objects, either particle masses or rigid bodies, experience very high force of interaction for a very small duration. It is not essential for the objects to physically touch each other for collision to occur. Irrespective of the nature of interactive force and the nature of colliding bodies, Newton's second law holds

good on the system. Hence, momentum of the system before and after the collision remains conserved if no appreciable external force acts on the system during collision.

The amount of energy loss during collision, if at all, is indeed dependent on the nature of colliding objects. The energy loss is observed to be maximum when objects stick together after collision. The terminology is to define collision as 'elastic' if no energy loss takes place and to define collision as 'plastic' for maximum energy loss. The behaviour of system after collision depends on the position of

colliding objects as well. A unidirectional motion of colliding objects before collision can turn into two dimensional after collision if the line joining the centre of mass of the two colliding objects is not parallel to the direction of velocity of each particle before collision. Such type of collision is referred to as oblique collision which may be either two or three dimensional.

Which of the following collisions is one-dimensional?

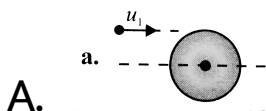

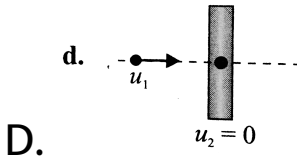
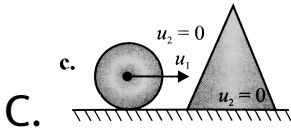
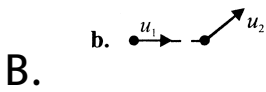

Answer: D

 **Watch Video Solution**

9. Collision is a physical process in which two or more objects, either particle masses or rigid bodies, experience very high force of

interaction for a very small duration. It is not essential for the objects to physically touch each other for collision to occur. Irrespective of the nature of interactive force and the nature of colliding bodies, Newton's second law holds good on the system. Hence, momentum of the system before and after the collision remains conserved if no appreciable external force acts on the system during collision.

The amount of energy loss during collision, if at all, is indeed dependent on the nature of colliding objects. The energy loss is observed to be maximum when objects stick together

after collision. The terminology is to define collision as 'elastic' if no energy loss takes place and to define collision as 'plastic' for maximum energy loss. The behaviour of system after collision depends on the position of colliding objects as well. A unidirectional motion of colliding objects before collision can turn into two dimensional after collision if the line joining the centre of mass of the two colliding objects is not parallel to the direction of velocity of each particle before collision. Such type of collision is referred to as oblique collision which may be either two or three

dimensional.

Which of the following collisions is one-dimensional?

A. Elastic, one-dimensional

B. Inelastic, one-dimensional

C. Elastic, two-dimensional

D. Inelastic, two-dimensional

Answer: D



Watch Video Solution

10. According to the principle of conservation of linear momentum if the external force acting on the system is zero, the linear momentum of the system will remain conserved. It means if the centre of mass of a system is initially at rest, it will remain at rest in the absence of external force, that is, the displacement of centre of mass will be zero.

A plank of mass M is placed on a smooth horizontal surface. light identical springs, each of stiffness K , are rigidly connected to struts at the end of the plank as shown in Fig. When

the springs are in their unextended position, the distance between their free ends is $3l$. A block of mass m is placed on the plank and pressed against one of the springs so that it is compressed to l . To keep the block at rest it is connected to the strut means of a light string. Initially, the system is at rest, Now the string is burnt.

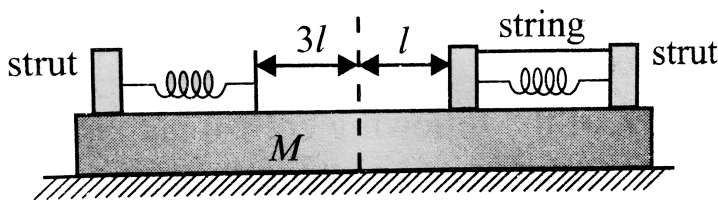

The maximum kinetic energy of the block m is

A. $\frac{5ml}{M}$

B. $\frac{5ml}{M + m}$

C. $\frac{3ml}{M + m}$

D. $\frac{4ml}{M + m}$

Answer: B



Watch Video Solution

11. According to the principle of conservation of linear momentum if the external force acting on the system is zero, the linear momentum of the system will remain

conserved. It means if the centre of mass of a system is initially at rest, it will remain at rest in the absence of external force, that is, the displacement of centre of mass will be zero.

A plank of mass M is placed on a smooth horizontal surface. Light identical springs, each of stiffness K , are rigidly connected to struts at the end of the plank as shown in Fig. When the springs are in their unextended position, the distance between their free ends is $3l$. A block of mass m is placed on the plank and pressed against one of the springs so that it is compressed to l . To keep the block at rest it is

connected to the strut means of a light string.

Initially, the system is at rest, Now the string is

burnt.

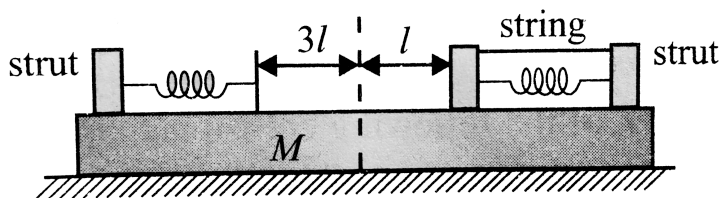

The maximum kinetic energy of the block m is

A. $\sqrt{\frac{Km}{(M+m)}l}$

B. $\sqrt{\frac{k}{(M+m)}l}$

C. $\sqrt{\frac{Km}{M(M+m)}l}$

D. $\sqrt{\frac{kM}{m(M+m)}l}$

Answer: C



Watch Video Solution

12. According to the principle of conservation of linear momentum if the external force acting on the system is zero, the linear momentum of the system will remain conserved. It means if the centre of mass of a system is initially at rest, it will remain at rest in the absence of external force, that is, the displacement of centre of mass will be zero.

A plank of mass M is placed on a smooth horizontal surface. Two light identical springs, each of stiffness K , are rigidly connected to struts at the end of the plank as shown in Fig. When the springs are in their unextended position, the distance between their free ends is $3l$. A block of mass m is placed on the plank and pressed against one of the springs so that it is compressed to l . To keep the block at rest it is connected to the strut means of a light string. Initially, the system is at rest, Now the string is burnt.

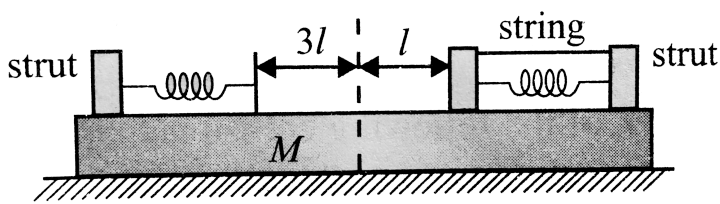

The maximum kinetic energy of the block m is

A. $\frac{Kml^2}{2M(M + m)}$

B. $\frac{Kml^2}{M(M + m)}$

C. $\frac{KMl^2}{2(M + m)}$

D. none of these

Answer: C



Watch Video Solution

13. Two identical balls A and B , each of mass $2kg$ and radius R , are suspended vertically from inextensible strings as shown in Fig. The third ball C of mass $1kg$ and radius $r = (\sqrt{2} - 1)R$ falls and hits A and B symmetrically with $10m/s$. Speed of both A and B just after the collision is $3m/s$.

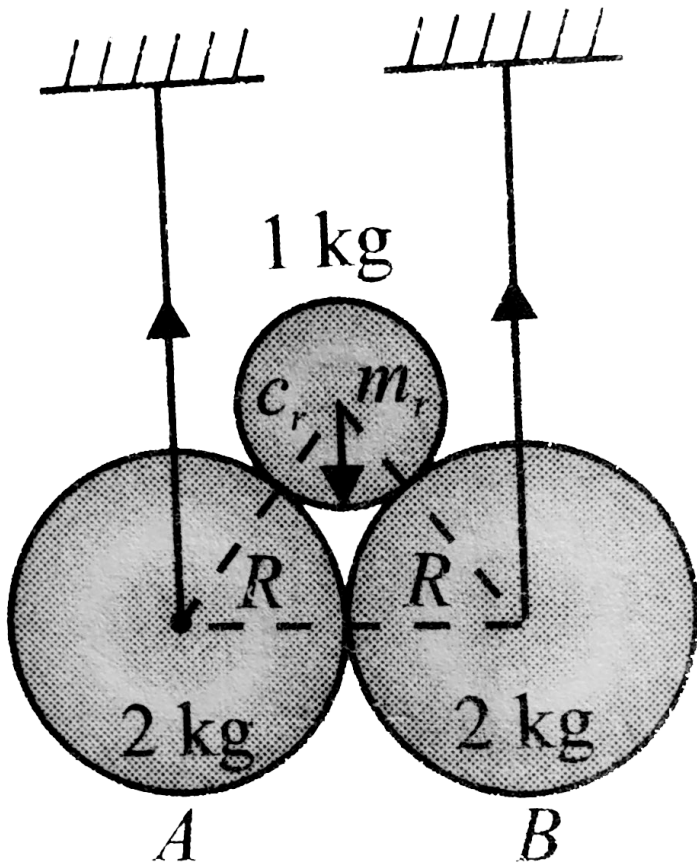

speed of C just asfer collision is

A. $2m / s$

B. $2\sqrt{2}m / s$

C. $5m / s$

D. $(\sqrt{2} - 1)m / s$

Answer: A



Watch Video Solution

14. Two identical balls A and B , each of mass $2kg$ and radius R , are suspended vertically from inextensible strings as shown in Fig. The third ball C of mass $1kg$ and radius $r = (\sqrt{2} - 1)R$ falls and hits A and B

symmetrically with $10m/s$. Speed of both A and B just after the collision is $3m/s$.

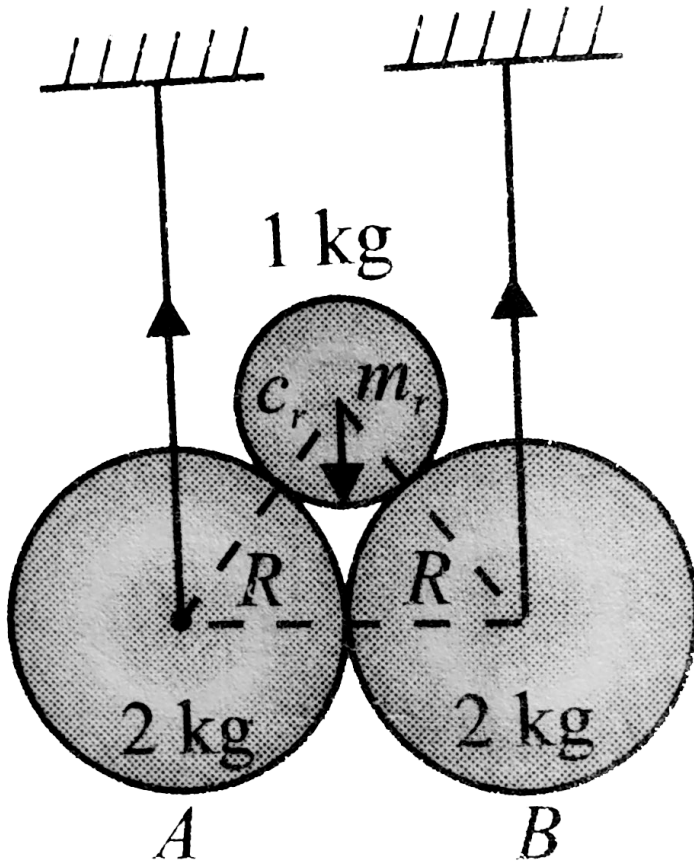

Impulse provided by each sting during collision is

A. $6\sqrt{2}Ns$

B. $12Ns$

C. $3\sqrt{2}Ns$

D. $6Ns$

Answer: D



Watch Video Solution

15. Two identical balls A and B . each of mass $2kg$ and radius R , are suspended vertically from inextensible strings as shown in Fig. The

third ball C of mass $1kg$ and radius $r = (\sqrt{2} - 1)R$ falls and hits A and B symmetrically with $10m/s$. Speed of both A and B just after the collision is $3m/s$.

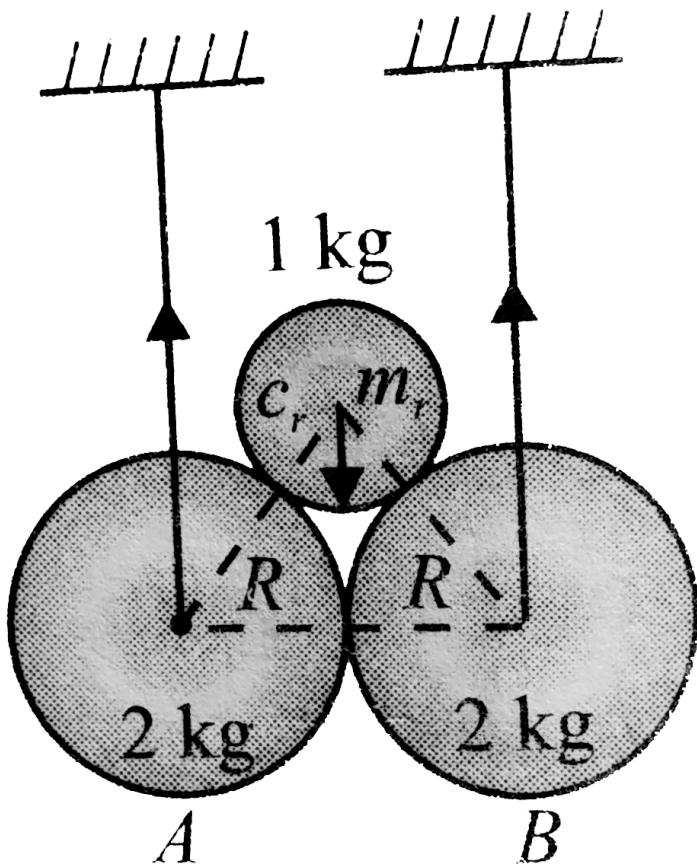

The value of coefficient of restitution is

A. $\frac{1}{4}$

B. $\frac{1}{\sqrt{2}}$

C. $\sqrt{2} - 1$

D. $\frac{1}{2}$

Answer: D



Watch Video Solution

16. After falling from rest through a height h , a body of mass m begins to raise a body of mass M ($M > m$) connected to it through a pulley. Determine the time it will take for the body of mass M to return to its original position

A. $\frac{2m}{M_m} \sqrt{\frac{2h}{g}}$

B. $\frac{2m}{M - m} \sqrt{\frac{2h}{g}}$

C. $\frac{2m}{M - m} \sqrt{\frac{h}{g}}$

D. $\frac{m}{M - m} \sqrt{\frac{2h}{g}}$

Answer: B



Watch Video Solution

17. After falling from rest through a height h , a body of mass m begins to raise a body of mass

$M(M > m)$ connected to it through a pulley.

Find the fraction of kinetic energy lost when the body of mass M is jerked into motion

A. $\frac{M}{M + m}$

B. $\frac{M}{M - m}$

C. $\frac{2M}{M + m}$

D. $\frac{M}{2(M + m)}$

Answer: A



Watch Video Solution

18. Three identical balls are connected by light inextensible strings with each other as shown and rest over a smooth horizontal table. Length of each string is l .

At moment $t = 0$, ball B is imparted a velocity v_0 perpendicular to the strings and then the system is left on its own.

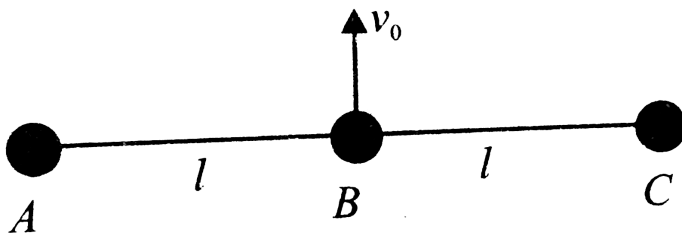

If collision between the balls is completely inelastic, then

A. $\frac{v_0}{3}$

B. $\frac{2v_0}{3}$

C. $\frac{2v_0}{5}$

D. none of these

Answer: A



Watch Video Solution

19. Three identical balls are connected by light inextensible strings with each other as shown and rest over a smooth horizontal table.

Length of each string is l .

At moment $t = 0$, ball B is imparted a velocity v_0 perpendicular to the strings and then the system is left on its own.

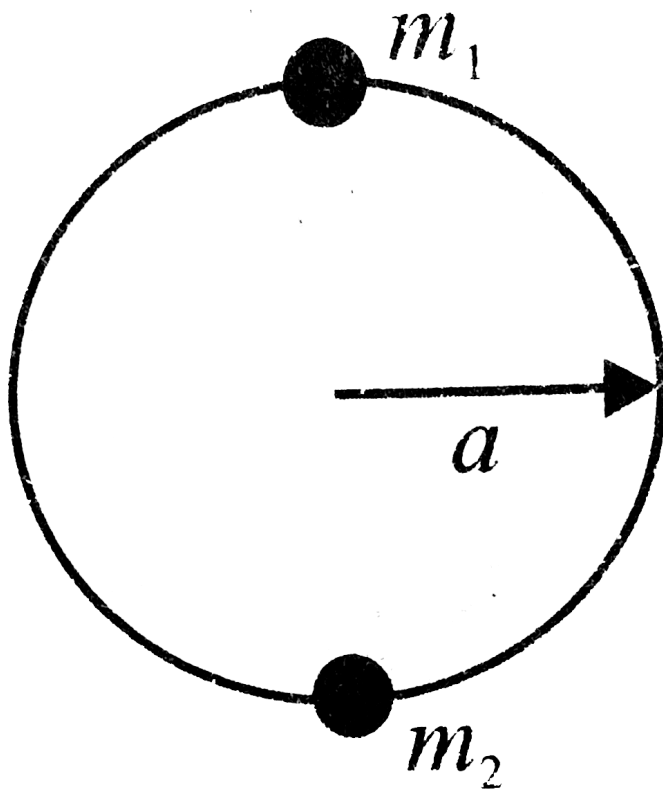

Calculate the velocity of A at the above given instant.

A. a. $\frac{v_0}{3}$

B. b. $\frac{2v_0}{3}$

C. c. $\frac{2v_0}{6}$

D. d. none of these

Answer: B



Watch Video Solution

20. Three identical balls are connected by light inextensible strings with each other as shown and rest over a smooth horizontal table. Length of each string is l .

At moment $t = 0$, ball B is imparted a velocity v_0 perpendicular to the strings and then the system is left on its own.

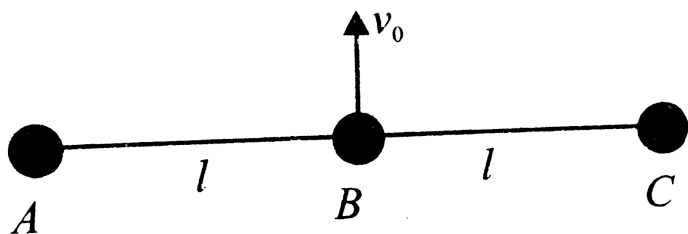

If collision between the balls is completely inelastic, then

A. there is no loss of kinetic energy of the system

B. entire kinetic energy of the system is lost

C. kinetic energy loss in the system is less than 50 %

D. kinetic energy loss in the system is more than 50 %

Answer: D



Watch Video Solution

21. In Fig. a pulley is shown which is frictionless and a ring of mass m can slide on the string without any friction. One end of the string is attached to point B and to the other end, a block ' P ' of mass m is attached. The whole system lies in vertical plane.

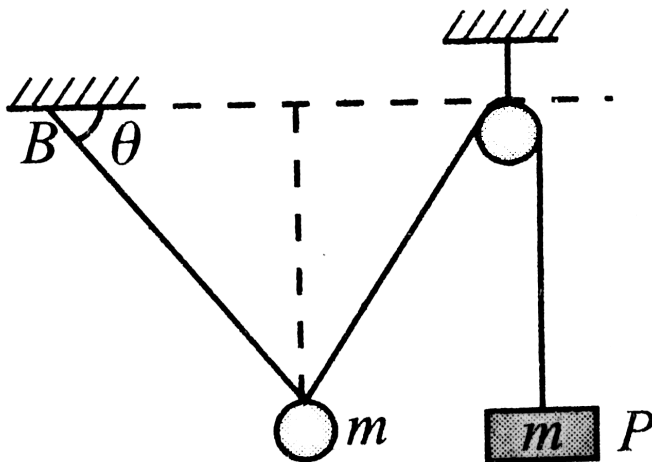

If the

system is released from rest, it is found that

the system remains at rest. What is the value of θ

A. 30°

B. 45°

C. 60°

D. 75°

Answer: A



Watch Video Solution

22. In Fig. a pulley is shown which is frictionless and a ring of mass m can slide on the string without any friction. One end of the string is attached to point B and to the other end, a block ' P ' of mass m is attached. The whole system lies in vertical plane.

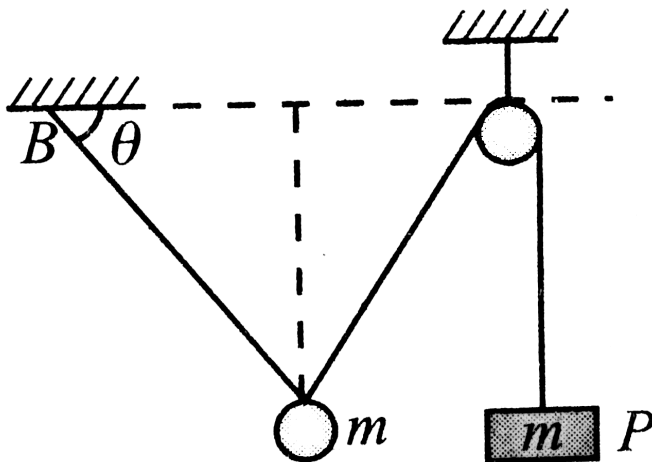

Now

another block ' C ' of same mass m is attached

to the block ' P ' and system is released from rest. If a_1 and a_2 are the magnitudes of initial accelerations of ring and blocks, respectively, then

A. $a_1 + a_2 = g$

B. $a_1 + 2a_2 = g$

C. $a_1 = 2a_2$

D. $2a_1 = a_2$

Answer: B



Watch Video Solution

23. In Fig. a pulley is shown which is frictionless and a ring of mass m can slide on the string without any friction. One end of the string is attached to point B and to the other end, a block ' P ' of mass m is attached. The whole system lies in vertical plane.

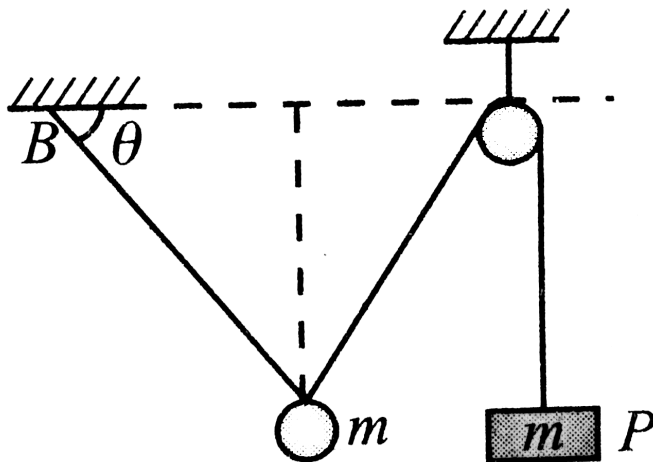

If block

' C ' mentioned above was released from some

height and collided with ' P ' with some velocity u , then find the velocity of the ring just after the collision. The collision is perfectly inelastic.

A. u

B. $\frac{u}{2}$

C. $\frac{u}{4}$

D. $\frac{u}{3}$

Answer: D



Watch Video Solution

24. A system of men and trolley is shown in Fig. To the left, end of the string, a trolley of mass M is connected on which a man of mass m is standing. To the right end of the string another trolley of mass m is connected on which a man of mass M is standing. Initially, the system is at rest. All of a sudden both the men leap upwards simultaneously with the same velocity u w.r.t. ground.

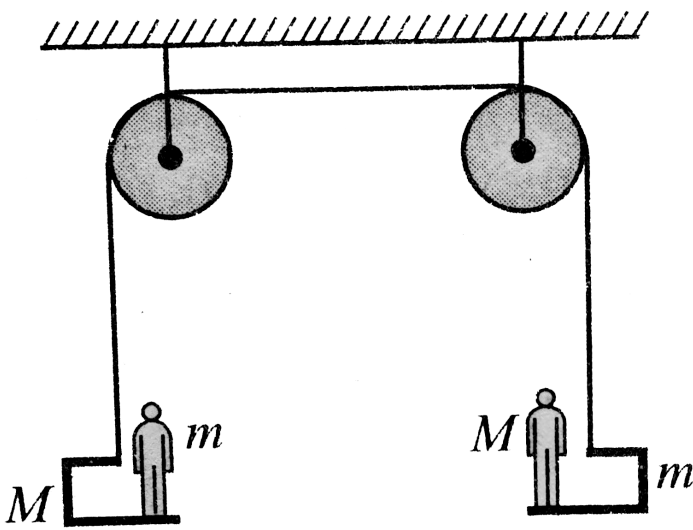

Find the relative velocity of left man with respect to his trolley just after he leaps upwards.

A. $\frac{mu}{m + M}$

B. $\frac{Mu}{m + M}$

C. $\frac{2mu}{m + M}$

D. $\frac{2mu}{m + M}$

Answer: C



Watch Video Solution

25. A system of men and trolley is shown in Fig. To the left, end of the string, a trolley of mass M is connected on which a man of mass m is standing. To the right end of the string another trolley of mass m is connected on which a man of mass M is standing. Initially,

the system is at rest. All of a sudden both the men leap upwards simultaneously with the same velocity u w.r.t. ground.

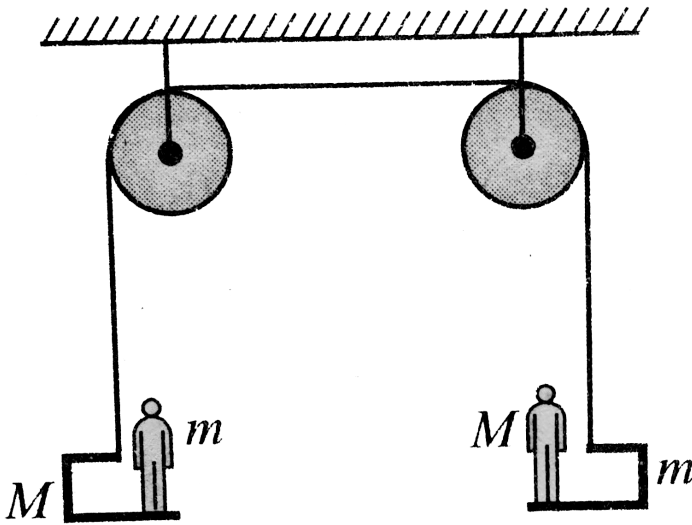

Find the impulse generated in the string connecting the trolleys during this process.

- A. $\frac{Mmu}{m + M}$
- B. $\frac{(M^2 + m^2)u}{m + M}$

C. $\frac{m^2u}{m + M}$

D. $\frac{M^2u}{m + M}$

Answer: B



Watch Video Solution

26. A system of men and trolley is shown in Fig. To the left, end of the string, a trolley of mass M is connected on which a man of mass m is standing. To the right end of the string another trolley of mass m is connected on

which a man of mass M is standing. Initially, the system is at rest. All of a sudden both the men leap upwards simultaneously with the same velocity u w.r.t. ground.

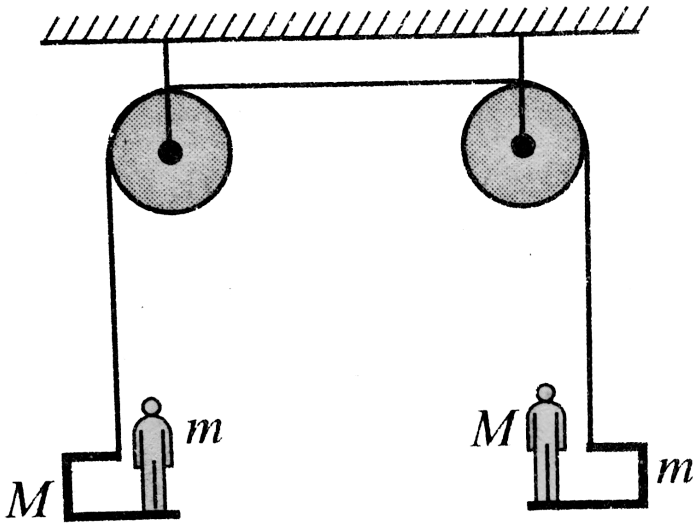

Find the relative velocity of left man with respect to his trolley just after he leaps upwards.

A. When the men are at the highest point of their motion, the trolleys will also be instantaneously at rest.

B. When the men are at the highest point of their motion, then the left trolley will be moving downwards.

C. Impulse acting on both the men will be same in the given process.

D. None of these

Answer: A



Watch Video Solution

27. Two beads A and B of masses m_1 and m_2 respectively, are threaded on a smooth circular wire of radius a fixed in a vertical plane. B is stationary at the lowest point when A is gently dislodged from rest at the highest point. A collided with B at the lowest point. The impulse given to B due to collision is just great enough to carry it to the level of the centre of the circle while A is immediately brought to rest by the impact.

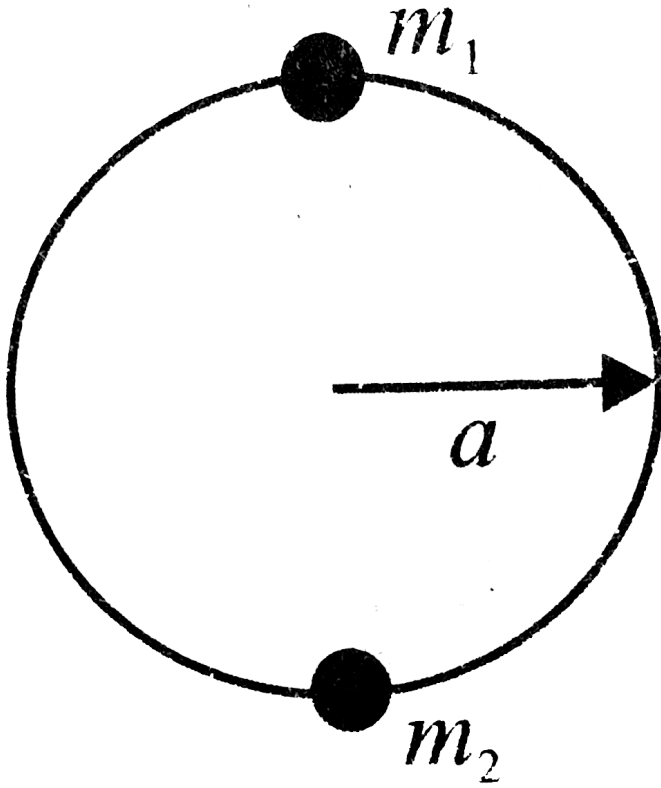

Find the ratio $m_1 : m_2$

- A. 1
- B. $\sqrt{2}$
- C. $\frac{1}{\sqrt{2}}$

D. 2

Answer: C



Watch Video Solution

28. Two beads A and B of masses m_1 and m_2 respectively, are threaded on a smooth circular wire of radius a fixed in a vertical plane. B is stationary at the lowest point when A is gently dislodged from rest at the highest point. A collided with B at the lowest point.

The impulse given to B due to collision is just great enough to carry it to the level of the centre of the circle while A is immediately brought to rest by the impact.

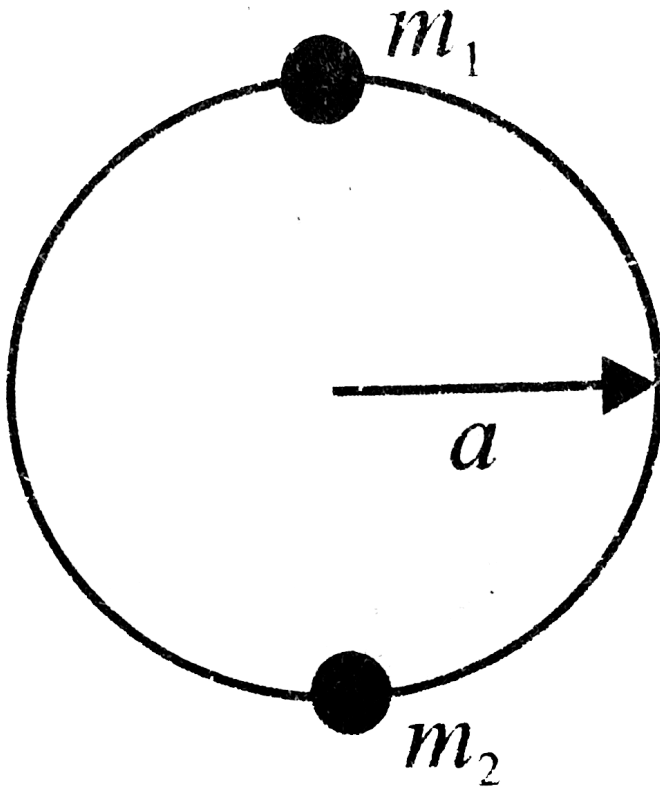

What is

the coefficient of restituting between the beads?

A. 1

B. $\frac{1}{2}$

C. $\frac{1}{3}$

D. $\frac{1}{\sqrt{2}}$

Answer: D



Watch Video Solution

29. Two beads A and B of masses m_1 and m_2 respectively, are threaded on a smooth circular wire of radius a fixed in a vertical plane. B is stationary at the lowest point when A is gently dislodged from rest at the highest point. A collided with B at the lowest point. The impulse given to B due to collision is just great enough to carry it to the level of the centre of the circle while A is immediately brought to rest by the impact.

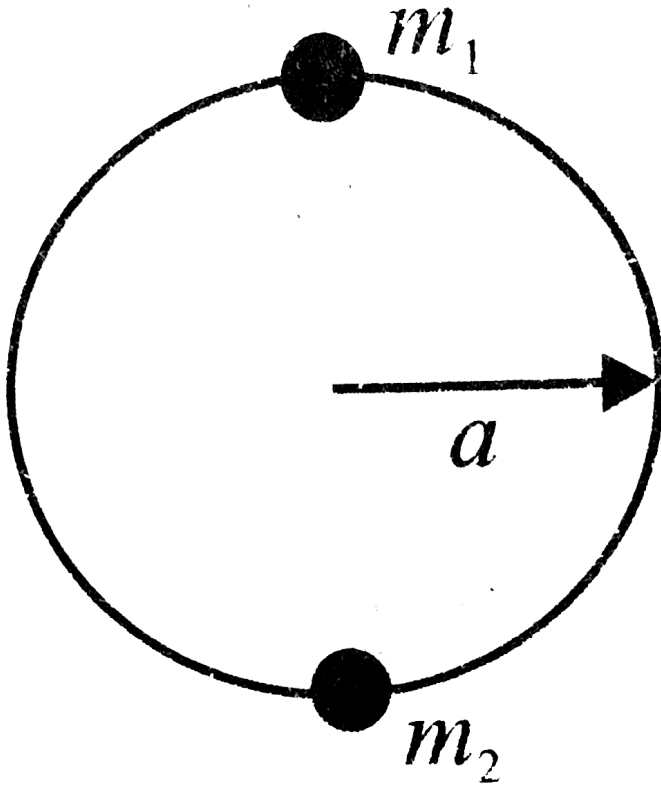

If m_2 again comes down and collides with m_1
then after the collision

A. m_1 will rise the same height as risen by

m_2

B. m_1 will rise the less height as risen by

m_2

C. m_1 will rise the more height as risen by

m_2

D. m_1 and m_2 will move in opposite

directions

Answer: A



Watch Video Solution

30. Two blocks of equal mass m are connected by an unstretched spring and the system is kept at rest on a frictionless horizontal surface. A constant force F is applied on the first block pulling it away from the other as shown in figure.

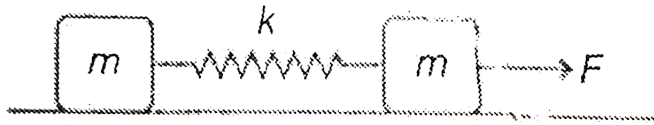

Then the displacement of the centre of mass at time t is

A. $\frac{Ft^2}{2m}$

B. $\frac{Ft^2}{3m}$

C. $\frac{Ft^2}{4m}$

D. $\frac{Ft^2}{m}$

Answer: C



Watch Video Solution

31. Two block of equal mass m are connected by an unstretched spring and the system is kept at rest on a frictionless horizontal surface. A constant force F is applied on the first block

pulling it away from the other as shown in

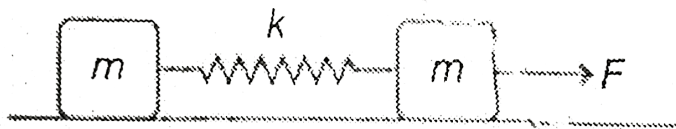

figure.

If the extension of the spring is x_0 at time t , then the displacement of the first block at this instant is

A. $\frac{1}{2} \left(\frac{Ft^2}{2m} + x_0 \right)$

B. $-\frac{1}{2} \left(\frac{Ft^2}{2m} + x_0 \right)$

C. $\frac{1}{2} \left(\frac{Ft^2}{2m} - x_0 \right)$

D. $\frac{Ft^2}{2m} + x_0$

Answer: A



Watch Video Solution

32. Two blocks of equal mass m are connected by an unstretched spring and the system is kept at rest on a frictionless horizontal surface. A constant force F is applied on the first block pulling it away from the other as shown in figure.

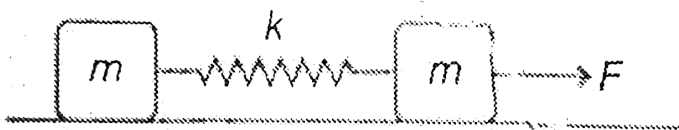

figure.

If the extension of the spring is x_0 at time t , then the displacement of the first block at this instant is

A. $\frac{Ft^2}{2m} - x_0$

B. $\frac{1}{2} \left(\frac{Ft^2}{2m} + x_0 \right)$

C. $\frac{1}{2} \left(\frac{2F^2}{m} - x_0 \right)$

D. $\frac{1}{2} \left(\frac{Ft^2}{2m} - x_0 \right)$

Answer: D



Watch Video Solution

33. Two equal spheres B and C , each of mass m , are in contact on a smooth horizontal table. A third sphere A of same size as that of

B or C but mass $m/2$ impinges symmetrically on them with a velocity u and is itself brought to rest.

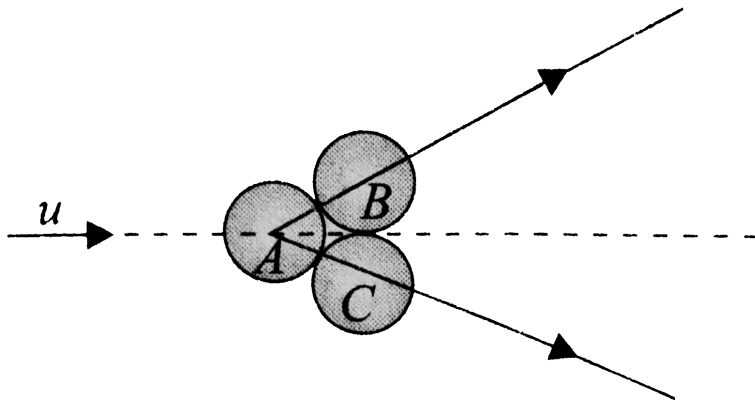

The coefficient of restitution between the two spheres A and B (or between A and C) is

A. $1/3$

B. $1/4$

C. $2/3$

D. $3/4$

Answer: A



Watch Video Solution

34. Two equal spheres B and C , each of mass m , are in contact on a smooth horizontal table. A third sphere A of same size as that of B or C but mass $m/2$ impinges symmetrically on them with a velocity u and is itself brought

to rest.

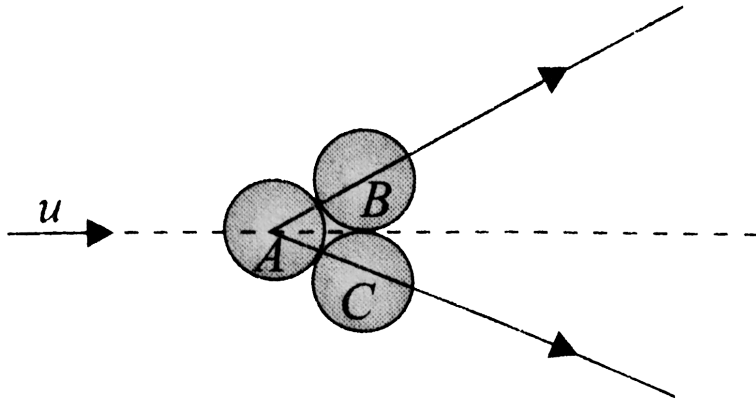

Find the velocity acquired by each of the spheres B and C after collision.

A. $\frac{u}{\sqrt{3}}$

B. $\frac{2u}{\sqrt{3}}$

C. $\frac{u}{2\sqrt{3}}$

D. $\frac{u}{2}$

Answer: C



Watch Video Solution

35. Two equal spheres B and C , each of mass m , are in contact on a smooth horizontal table. A third sphere A of same size as that of B or C but mass $m/2$ impinges symmetrically on them with a velocity u and is itself brought to rest.

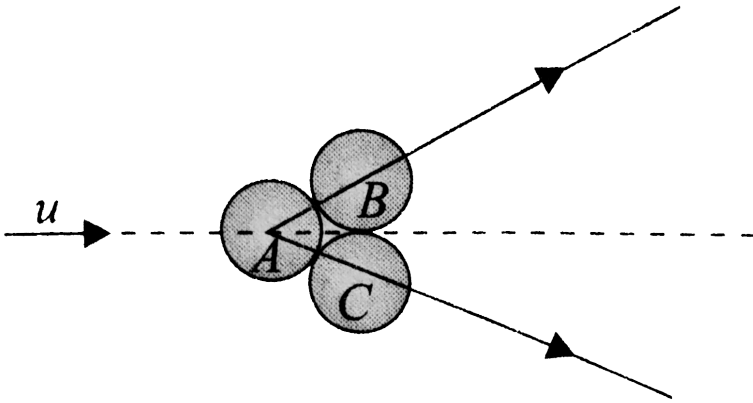

The loss of KE during collision is

A. $\frac{mu^2}{8}$

B. $\frac{mu^2}{6}$

C. $\frac{mu^2}{3}$

D. $\frac{mu^2}{2}$

Answer: B



Watch Video Solution

36. A pendulum consists of a wooden bob of mass M and length l . A bullet of mass m is fired towards the pendulum with a speed v . The bullet emerges immediately out of the bob from the other side with a speed of $v/2$ and the bob starts rising. Assume no loss of mass of bob takes place due to penetration.

What is the momentum transferred to the bob by the bullet?

A. mv

B. $\frac{mv}{2}$

C. $\frac{Mv}{2}$

D. Mv

Answer: B



Watch Video Solution

37. A pendulum consists of a wooden bob of mass M and length l . A bullet of mass m is fired towards the pendulum with a speed v .

The bullet emerges immediately out of the bob from the other side with a speed of $v/2$ and the bob starts rising. Assume no loss of mass of bob takes place due to penetration.

If the bob stops where the string becomes horizontal then v is

A. $\frac{2M}{m} \sqrt{3gl}$

B. $\frac{2M}{m} \sqrt{5gl}$

C. $\frac{2M}{m} \sqrt{gl}$

D. $\frac{2M}{m} \sqrt{2gl}$

Answer: D



Watch Video Solution

38. A pendulum consists of a wooden bob of mass M and length l . A bullet of mass m is fired towards the pendulum with a speed v . The bullet emerges immediately out of the bob from the other side with a speed of $v/2$ and the bob starts rising. Assume no loss of mass of bob takes place due to penetration.

If the bob is just able to complete the circular motion, then tension at the lowest point just when the bob starts rising will be

A. $6Mg$

B. $5Mg$

C. $3Mg$

D. Mg

Answer: A



Watch Video Solution

39. According to the principle of conservation of linear momentum, if the external force acting on the system is zero, the linear

momentum of the system will remain conserved. It means if the centre of mass of a system is initially at rest, it will remain, at rest in the absence of external force, that is, the displacement of centre of mass will be zero.

Two blocks of masses ' m ' and ' $2m$ ' are placed as shown in Fig. There is no friction anywhere. A spring of force constant k is attached to the bigger block. Mass ' m ' is kept in touch with the spring but not attached to it. ' A ' and ' B ' are two supports attached to ' $2m$ '. Now m is moved towards left so that spring is compressed by distance ' x ' and then

the system is released from rest.

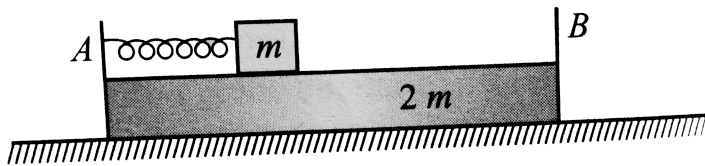

Find the relative velocity of the blocks after ' m ' leaves contact with the spring.

A. $\sqrt{\frac{2k}{3m}}$

B. $3x\sqrt{\frac{k}{2m}}$

C. $x\sqrt{\frac{3k}{2m}}$

D. none of these

Answer: C



Watch Video Solution

40. According to the principle of conservation of linear momentum, if the external force acting on the system is zero, the linear momentum of the system will remain conserved. It means if the centre of mass of a system is initially at rest, it will remain, at rest in the absence of external force, that is, the displacement of centre of mass will be zero.

Two blocks of masses ' m ' and ' $2m$ ' are placed as shown in Fig. There is no friction anywhere. A spring of force constant k is

attached to the bigger block. Mass ' m ' is kept in touch with the spring but not attached to it. ' A ' and ' B ' are two supports attached to ' $2m$ '. Now m is moved towards left so that spring is compressed by distance ' x ' and then the system is released from rest.

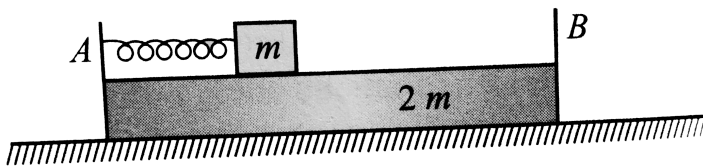

Find the relative velocity of the blocks after ' m ' leaves contact with the spring.

A. It is also reduced to half of its previous value

B. It is reduced to less than half of its previous value.

C. It is reduced to more than half of its previous value.

D. It remains the same.

Answer: A



Watch Video Solution

41. According to the principle of conservation of linear momentum, if the external force acting on the system is zero, the linear momentum of the system will remain conserved. It means if the centre of mass of a system is initially at rest, it will remain, at rest in the absence of external force, that is, the displacement of centre of mass will be zero.

Two blocks of masses ' m ' and ' $2m$ ' are placed as shown in Fig. There is no friction anywhere. A spring of force constant k is attached to the bigger block. Mass ' m ' is kept

in touch with the spring but not attached to it. 'A' and 'B' are two supports attached to '2m'. Now m is moved towards left so that spring is compressed by distance ' x ' and then the system is released from rest.

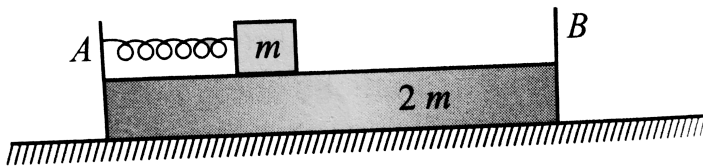

Find the relative velocity of the blocks after ' m ' leaves contact with the spring.

A. $\frac{3}{8}kx^2$

B. $\frac{3}{4}kx^2$

C. $\frac{1}{8}kx^2$

D. $\frac{5}{8}kx^2$

Answer: A



Watch Video Solution

42. A ballistic pendulum is a device that was used to measure the speeds of bullets before the development of electronic timing devices. The device consists of a large block of wood of mass M , hanging from two long cords. A bullet of mass m is fired into the block. the

bullet comes quickly into rest and the block + bullet rises to a vertical distance h before the pendulum comes momentarily to rest at the ends of the arc. In the process, the linear momentum is conserved. In such a collision, some kinetic energy is dissipated as heat: so mechanical energy is not conserved. When there is a loss in mechanical energy, the collision is said to be inelastic. Further when two bodies coalesce, the collision is said to be perfectly inelastic.

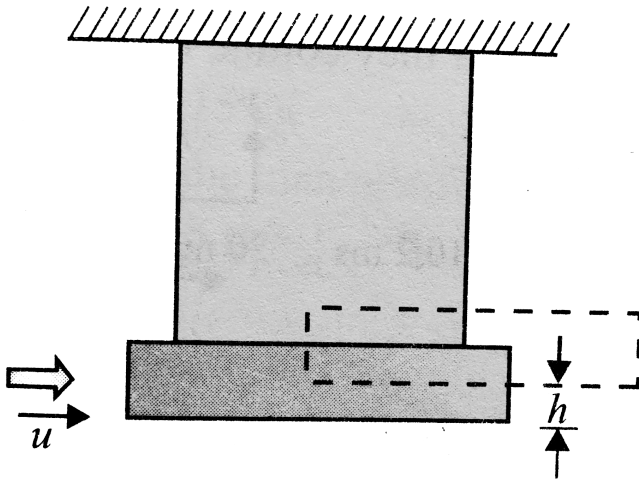

After collision what is the combined velocity of the bullet + block system?

A. $\frac{m}{M}u$

B. $\frac{m}{M+m}u$

C. $\frac{M}{M+m}u$

D. $\frac{M+m}{M}u$

Answer: B



Watch Video Solution

43. A ballistic pendulum is a device that was used to measure the speeds of bullets before the development of electronic timing devices.

The device consists of a large block of wood of mass M , hanging from two long cords. A bullet of mass m is fired into the block. The bullet comes quickly into rest and the block + bullet rises to a vertical distance h before

the pendulum comes momentarily to rest at the ends of the arc. In the process, the linear momentum is conserved. In such a collision, some kinetic energy is dissipated as heat: so mechanical energy is not conserved. When there is a loss in mechanical energy, the collision is said to be inelastic. Further when two bodies coalesce, the collision is said to be perfectly inelastic.

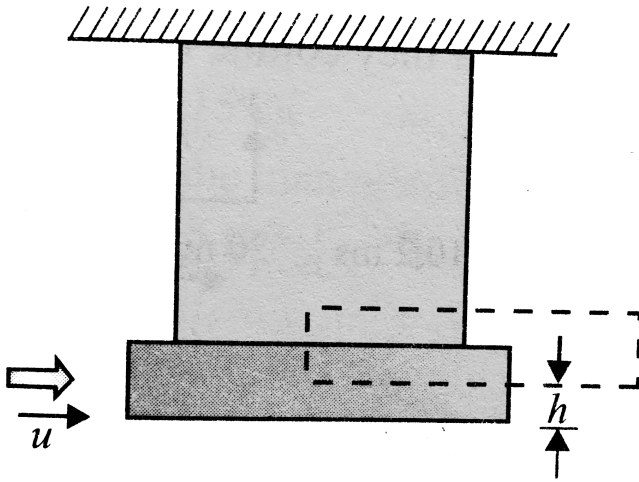

What is the initial speed of the bullet in terms of height h ?

- A. $\frac{m}{M} \sqrt{2gh}$
- B. $\frac{m}{M + m} \sqrt{2gh}$
- C. $\frac{M + m}{m} \sqrt{2gh}$
- D. $\sqrt{\frac{2m}{M + m} gh}$

Answer: C



Watch Video Solution

44. A ballistic pendulum is a device that was used to measure the speeds of bullets before the development of electronic timing devices. The device consists of a large block of wood of mass M , hanging from two long cords. A bullet of mass m is fired into the block. The bullet comes quickly into rest and the block + bullet rises to a vertical distance h before

the pendulum comes momentarily to rest at the ends of the arc. In the process, the linear momentum is conserved. In such a collision, some kinetic energy is dissipated as heat: so mechanical energy is not conserved. When there is a loss in mechanical energy, the collision is said to be inelastic. Further when two bodies coalesce, the collision is said to be perfectly inelastic.

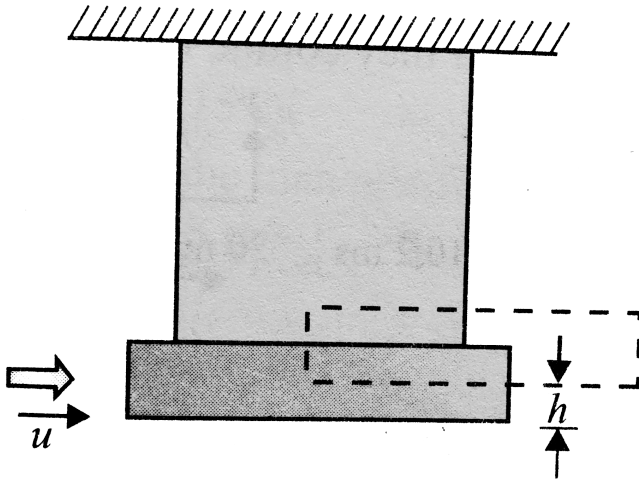

The collision of block-bullet system is

- A. perfectly elastic
- B. partially inelastic
- C. partially elastic
- D. perfectly inelastic

Answer: D



Watch Video Solution

45. A ballistic pendulum is a device that was used to measure the speeds of bullets before the development of electronic timing devices. The device consists of a large block of wood of mass M , hanging from two long cords. A bullet of mass m is fired into the block. The bullet comes quickly into rest and the block + bullet rises to a vertical distance h before

the pendulum comes momentarily to rest at the ends of the arc. In the process, the linear momentum is conserved. In such a collision, some kinetic energy is dissipated as heat: so mechanical energy is not conserved. When there is a loss in mechanical energy, the collision is said to be inelastic. Further when two bodies coalesce, the collision is said to be perfectly inelastic.

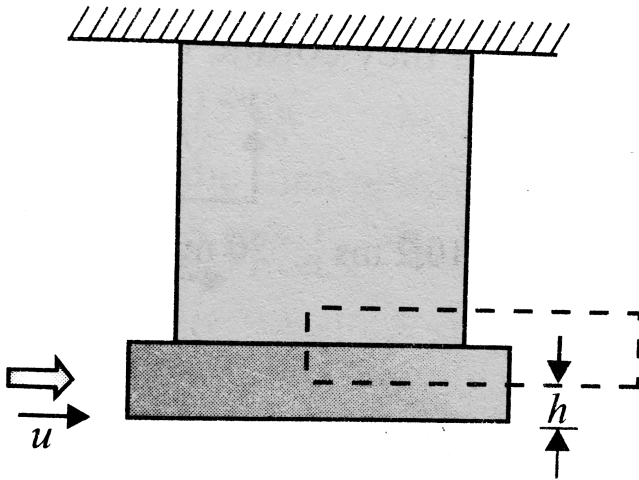

The energy dissipated as heat in the collision is

- A. $\frac{1}{2}mu^2 - mgh$
- B. $\frac{1}{2}mu^2 - (M + m)gh$
- C. $\frac{1}{2}(M + m)u^2 - (M + m)gh$
- D. cannot be estimated

Answer: B



Watch Video Solution

46. Two identical balls, each of mass m , are tied with a string and kept on a frictionless surface. Initially, the string is slack. They are given velocities $2u$ and u . in the same direction. Collision between the balls is perfectly elastic.

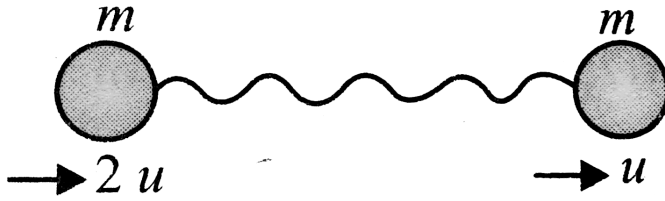

After the first collision, what is the total loss in kinetic energy of the balls?

A. $2mu^2$

B. mu^2

C. $3mu^2$

D. zero

Answer: D



Watch Video Solution

47. Two identical balls, each of mass m , are tied with a string and kept on a frictionless surface. Initially, the string is slack. They are given velocities $2u$ and u . in the same direction. Collision between the balls is perfectly elastic.

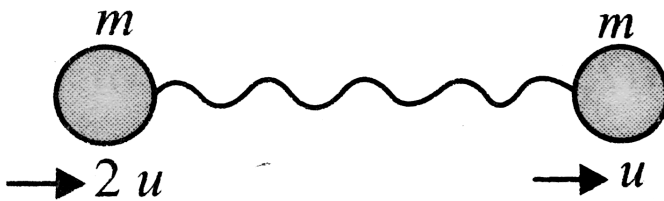

What is the final loss in kinetic energy of the balls?

A. $\mu^2 / 4$

B. $\mu^2 / 2$

C. $3\mu^2 / 4$

D. none of these

Answer: A



Watch Video Solution

48. Two identical balls, each of mass m , are tied with a string and kept on a frictionless surface. Initially, the string is slack. They are

given velocities $2u$ and u . in the same direction. Collision between the balls is perfectly elastic.

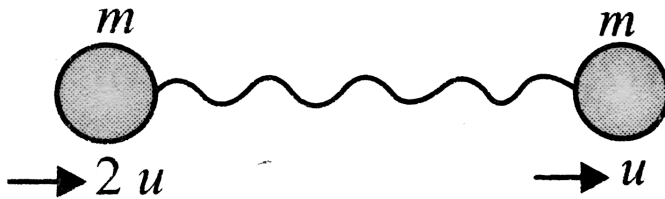

What is the impulse generated in the string during the first collision?

A. $mu/2$

B. $mu/4$

C. $(2mu)/3$

D. none of these

Answer: A



Watch Video Solution

49. The following problems illustrate the effect of a time-dependent force of a large average magnitude which acts on a moving object only for a short duration. Such forces are called 'impulsive' forces. According to the impulse-momentum theorem, impulse delivered to a

body is equal to the change of linear momentum of the body.

A ball of mass $250g$ is thrown with a speed of $30m/s$. The ball strikes a bat and it is hit straight back along the same line at a speed of $50m/s$. Variation of the interaction force, as long as the ball remains in contact with the bat, is as shown in Fig.

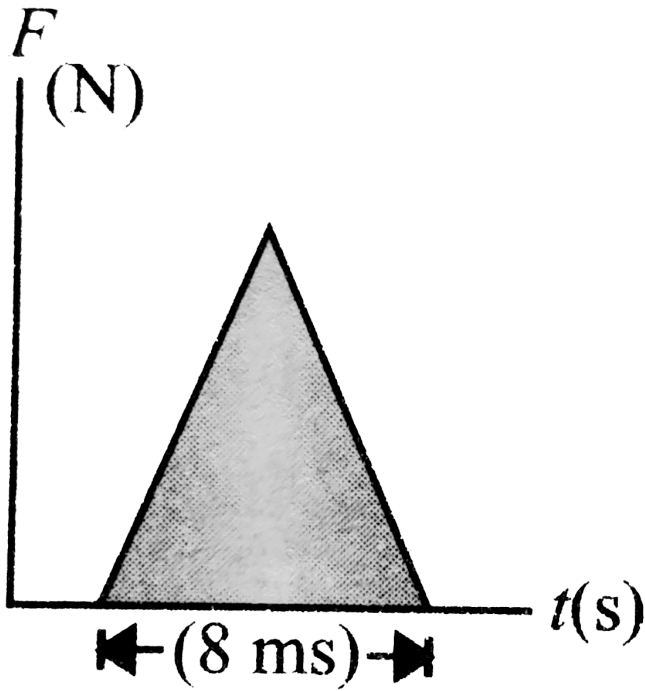

Maximum force exerted by the bat on the ball
is

A. $2500N$

B. $5000N$

C. $7500N$

D. $1250N$

Answer: B



Watch Video Solution

50. The following problems illustrate the effect of a time-dependent force of a large average magnitude which acts on a moving object only for a short duration. Such forces are called 'impulsive' forces. According to the impulse-

momentum theorem, impulse delivered to a body is equal to the change of linear momentum of the body.

A ball of mass $250g$ is thrown with a speed of $30m/s$. The ball strikes a bat and it is hit straight back along the same line at a speed of $50m/s$. Variation of the interaction force, as long as the ball remains in contact with the bat, is as shown in Fig.

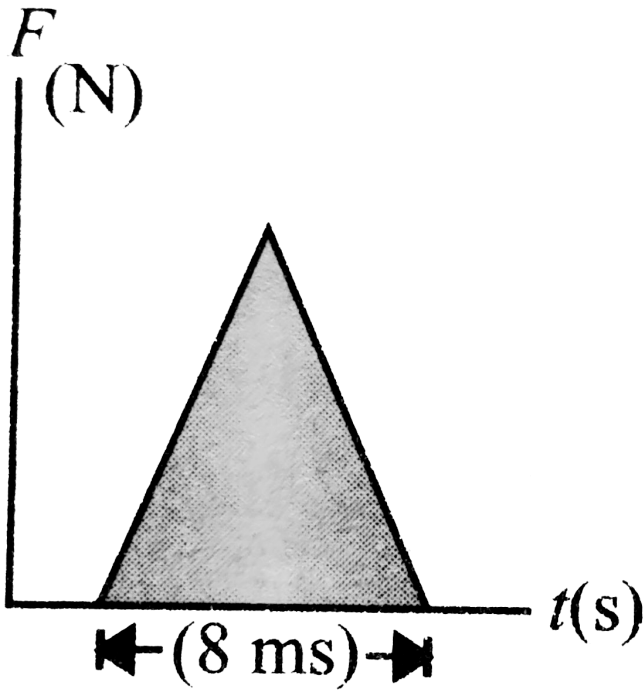

Maximum force exerted by the bat on the ball
is

A. $5000N$

B. $1250N$

C. $2500N$

D. $7500N$

Answer: C



Watch Video Solution

51. The following problems illustrate the effect of a time-dependent force of a large average magnitude which acts on a moving object only for a short duration. Such forces are called 'impulsive' forces. According to the impulse-

momentum theorem, impulse delivered to a body is equal to the change of linear momentum of the body.

A ball of mass $250g$ is thrown with a speed of $30m/s$. The ball strikes a bat and it is hit straight back along the same line at a speed of $50m/s$. Variation of the interaction force, as long as the ball remains in contact with the bat, is as shown in Fig.

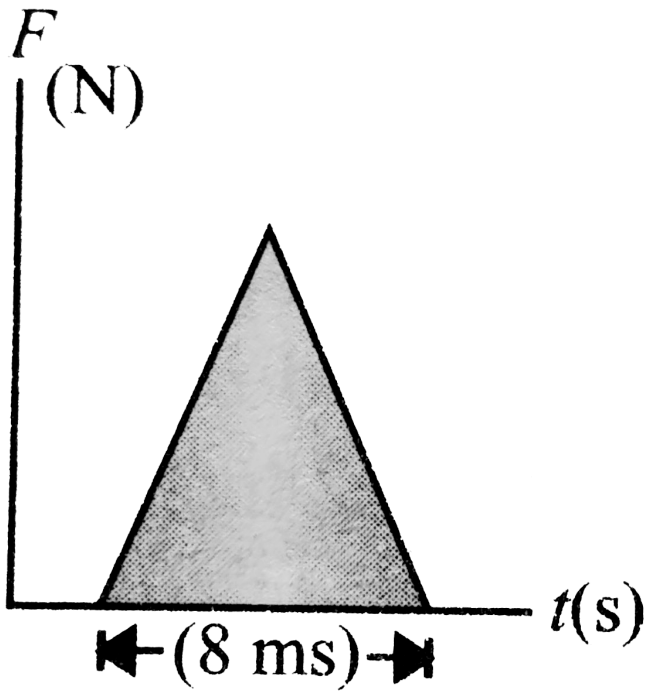

Maximum force exerted by the bat on the ball
is

A. $1.5 \text{ kgm} / \text{s}$

B. $2.5 \text{ kgm} / \text{s}$

C. $4\text{kgm} / \text{s}$

D. $0.5\text{kgm} / \text{s}$

Answer: A



Watch Video Solution

52. The following problems illustrate the effect of a time-dependent force of a large average magnitude which acts on a moving object only for a short duration. Such forces are called 'impulsive' forces. According to the impulse-

momentum theorem, impulse delivered to a body is equal to the change of linear momentum of the body.

A ball of mass $250g$ is thrown with a speed of $30m/s$. The ball strikes a bat and it is hit straight back along the same line at a speed of $50m/s$. Variation of the interaction force, as long as the ball remains in contact with the bat, is as shown in Fig.

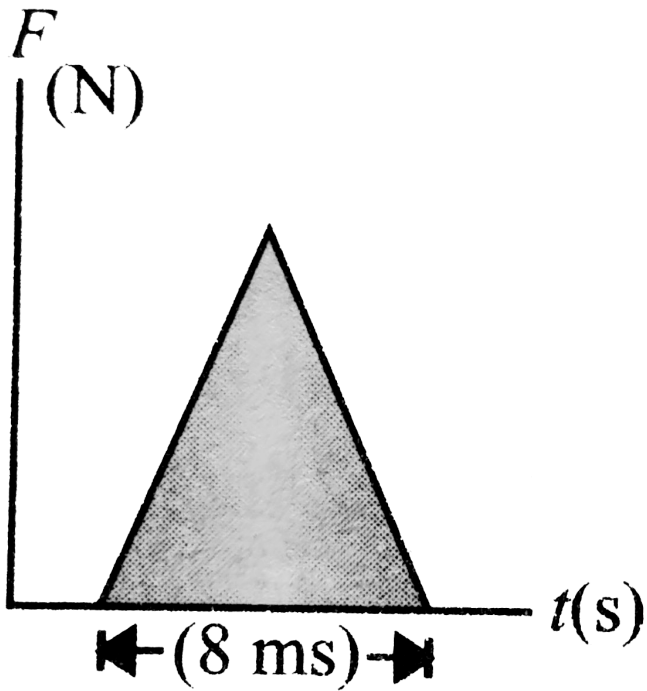

Maximum force exerted by the bat on the ball
is

A. $0.6m$

B. $2.4m$

C. $1.2m$

D. $1.8m$

Answer: D



Watch Video Solution

53. Two persons, A of mass $60kg$ and B of mass $40kg$, are standing on a horizontal platform of mass $50kg$. The platform is supported on wheels on a horizontal frictionless surface and is initially at rest. Consider the following

situations.

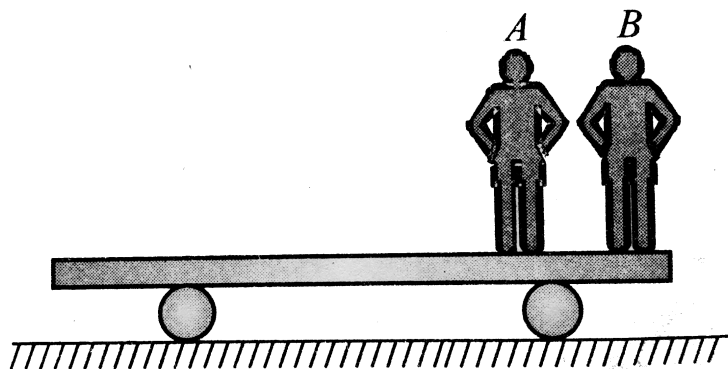

(i) Both A and B jump from the platform simultaneously and in the same horizontal direction.

(ii) A jumps first in a horizontal direction and after a few seconds B also jumps in the same direction. In both the situations above, just after the jump, the person (A or B) moves away from the platform with a speed of $3m/s$

relative to the platform and along the horizontal.

In situation (i), just after both A and B jump from the platform, velocity of centre of mass of the system (A , B and the platform) is

A. $2m / s$

B. $6m / s$

C. $5m / s$

D. none of these

Answer: D



Watch Video Solution

54. Two persons, A of mass 60kg and B of mass 40kg , are standing on a horizontal platform of mass 50kg . The platform is supported on wheels on a horizontal frictionless surface and is initially at rest. Consider the following situations.

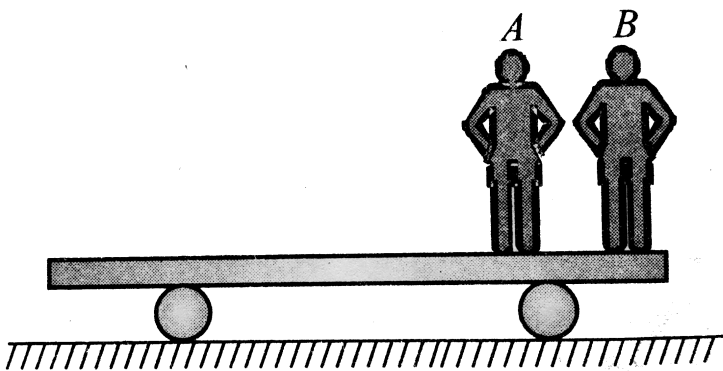

(i) Both A and B jump from the platform

simultaneously and in the same horizontal direction.

(ii) A jumps first in a horizontal direction and after a few seconds B also jumps in the same direction. In both the situations above, just after the jump, the person (A or B) moves away from the platform with a speed of 3 m/s relative to the platform and along the horizontal.

In situation (i), just after both A and B jump from the platform, velocity of centre of mass of the system (A , B and the platform) is

A. $2m / s$

B. $6m / s$

C. $5m / s$

D. none of these

Answer: A



Watch Video Solution

55. Two persons, A of mass $60kg$ and B of mass $40kg$, are standing on a horizontal platform of mass $50kg$. The platform is supported on

wheels on a horizontal frictionless surface and is initially at rest. Consider the following situations.

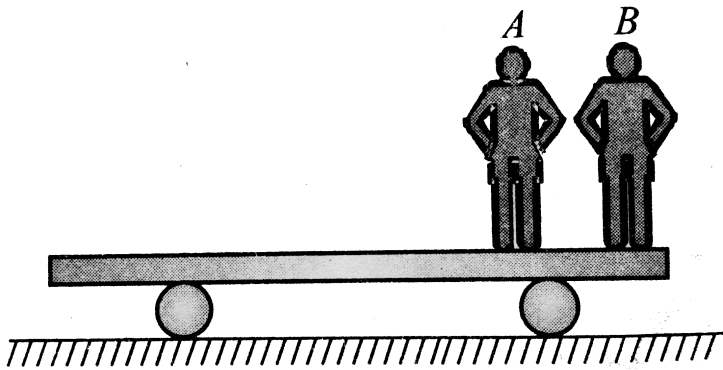

(i) Both A and B jump from the platform simultaneously and in the same horizontal direction.

(ii) A jumps first in a horizontal direction and after a few seconds B also jumps in the same direction. In both the situations above, just

after the jump, the person (A or B) moves away from the platform with a speed of $3m/s$ relative to the platform and along the horizontal.

In situation (i), just after both A and B jump from the platform, velocity of centre of mass of the system (A , B and the platform) is

A. $7.5m/s$

B. $5.5m/s$

C. $4.5m/s$

D. $2.5m/s$

Answer: D



Watch Video Solution

56. A string with one end fixed on a rigid wall, passing over a fixed frictionless pulley at a distance of $2m$ from the wall, has a point mass M of $2kg$ attached to it at a distance of $1m$ from the wall. A mass m of $0.5kg$ is attached to the free end. The system is initially held at rest so that the string is horizontal between wall and pulley and vertical beyond the pulley

as shown in figure.

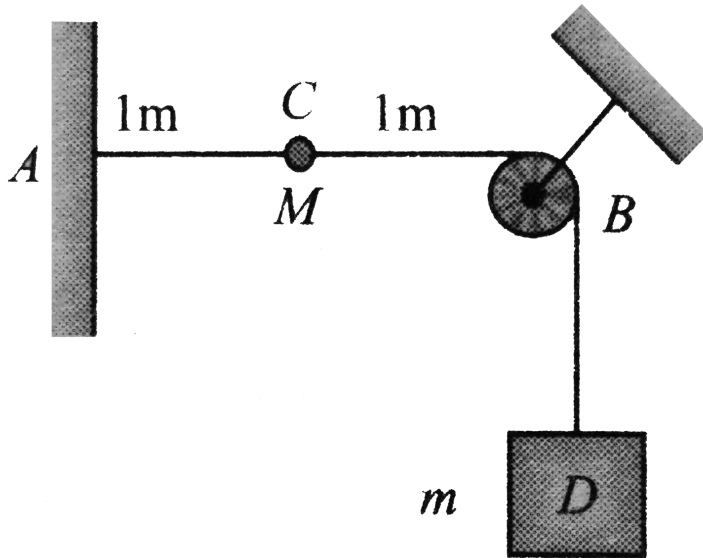

What will be the speed with which point mass M will hit the wall when the system is released? ($g = 10ms^{-2}$)

A. $\frac{\sqrt{5}}{2}$

B. $\frac{2}{\sqrt{5}}$

C. $\frac{3}{\sqrt{5}}$

D. $\frac{\sqrt{5}}{3}$

Answer: A



Watch Video Solution

57. A string with one end fixed on a rigid wall, passing over a fixed frictionless pulley at a distance of $2m$ from the wall, has a point mass M of $2kg$ attached to it at a distance of $1m$ from the wall. A mass m of $0.5kg$ is attached

to the free end. The system is initially held at rest so that the string is horizontal between wall and pulley and vertical beyond the pulley as shown in figure.

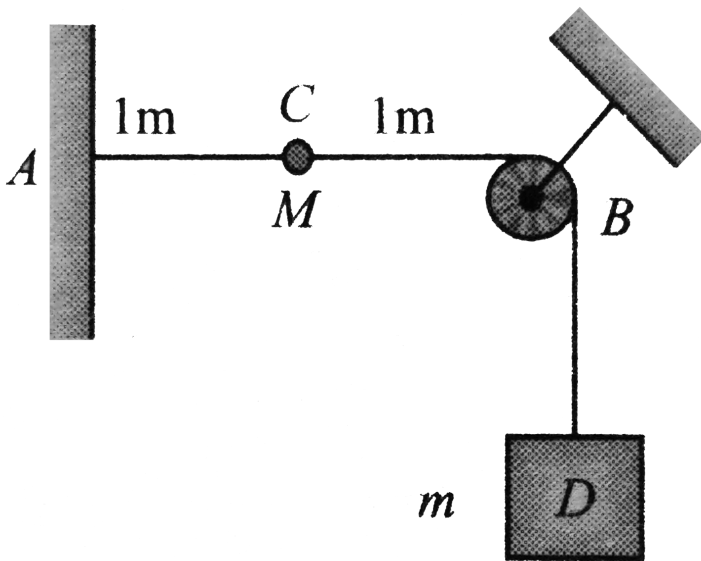

What will be the speed with which point mass M will hit the wall when the system is released? ($g = 10ms^{-2}$)

A. $2 \left(\frac{\sqrt{5 + \sqrt{5}}}{6} \right) m / s$

B. $2 \left(\frac{\sqrt{5 - \sqrt{5}}}{6} \right) m / s$

C. $5 \left(\frac{\sqrt{5 - \sqrt{5}}}{6} \right) m / s$

D. $5 \left(\frac{\sqrt{5 + \sqrt{5}}}{6} \right) m / s$

Answer: C



Watch Video Solution

58. Two identical shells are fired from a point on the ground with same muzzle velocity at

angle of elevation $\alpha = 45^\circ$ and $\beta = \tan^{-1} 3$ towards top of a cliff, $20m$ away from the point of firing. If both the shells reach the top simultaneously, then muzzle velocity is

A. $10m / s$

B. $5m / s$

C. $15m / s$

D. $20m / s$

Answer: D



Watch Video Solution

59. Two identical shells are fired from a point on the ground with same muzzle velocity at angle of elevation $\alpha = 45^\circ$ and $\beta = \tan^{-1} 3$ towards top of a cliff, $20m$ away from the point of firing. If both the shells reach the top simultaneously, then height of the cliff is

A. $20m$

B. $10m$

C. $15m$

D. $30m$

Answer: B



Watch Video Solution

60. Two identical shells are fired from a point on the ground with same muzzle velocity at angle of elevation $\alpha = 45^\circ$ and $\beta = \tan^{-1} 3$ towards top of a cliff, $20m$ away from the point of firing. If both the shells reach the top

simultaneously, then

time interval between two fringes is

A. $\sqrt{10} - \sqrt{2}s$

B. $\sqrt{10} + \sqrt{2}s$

C. $\sqrt{10} - \sqrt{3}s$

D. $\sqrt{10} + \sqrt{3}s$

Answer: A



Watch Video Solution

61. Two identical shells are fired from a point on the ground with same muzzle velocity at angle of elevation $\alpha = 45^\circ$ and $\beta = \tan^{-1} 3$ towards top of a cliff, $20m$ away from the point of firing. If both the shells reach the top simultaneously, then

If just before striking the top of cliff, the two shells get stuck together, considering elastic collision of combined body with the top of cliff, then maximum height reached by the combined body is

A. a. $20m$

B. b. $10m$

C. c. $24m$

D. $12m$

Answer: D



Watch Video Solution

62. A ball of mass m is thrown at an angle of 45° to the horizontal,, from the top of a $65m$ high tower AB as shown in Fig. at $t = 0$.

Another identical ball is thrown with velocity 20 m/s horizontally towards AB from the top of a 30 m high tower CD 1 s after the projection of the first ball. Both the balls move in the same vertical plane. If they collide in mid-air,

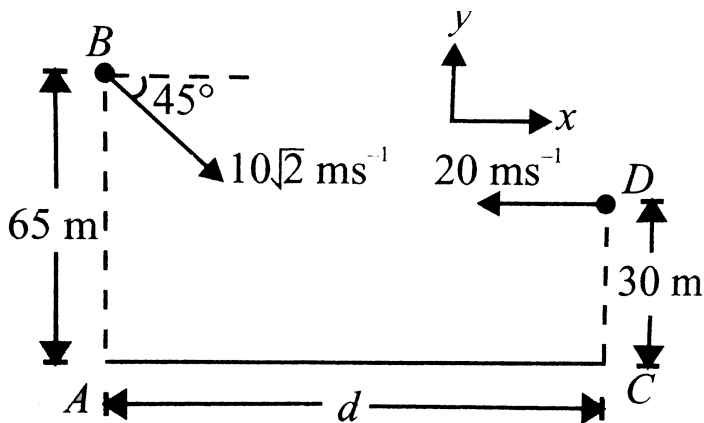

the two balls will collide at time $t =$

A. 2 s

B. $5s$

C. $10s$

D. $3s$

Answer: A



Watch Video Solution

63. A ball of mass m is thrown at an angle of 45° to the horizontal,, from the top of a $65m$ high tower AB as shown in Fig. at $t = 0$. Another identical ball is thrown with velocity

20 m/s horizontally towards AB from the top of a 30 m high tower CD after the projection of the first ball. Both the balls move in the same vertical plane. If they collide in mid-air,

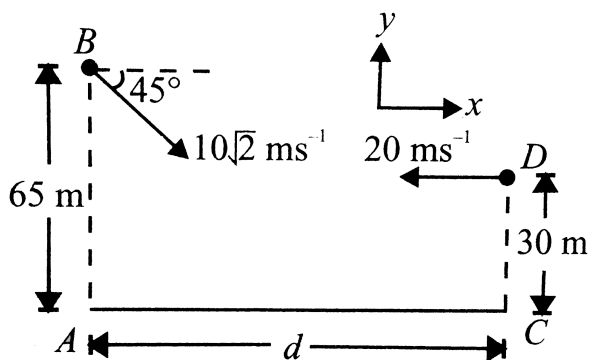

the height from the ground where the two balls will collide is

A. 15 m

B. $25m$

C. $10m$

D. $20m$

Answer: B



Watch Video Solution

64. A ball of mass m is thrown at an angle of 45° to the horizontal,, from the top of a $65m$ high tower AB as shown in Fig. at $t = 0$. Another identical ball is thrown with velocity

20 m/s horizontally towards AB from the top of a 30 m high tower CD after the projection of the first ball. Both the balls move in the same vertical plane. If they collide in mid-air,

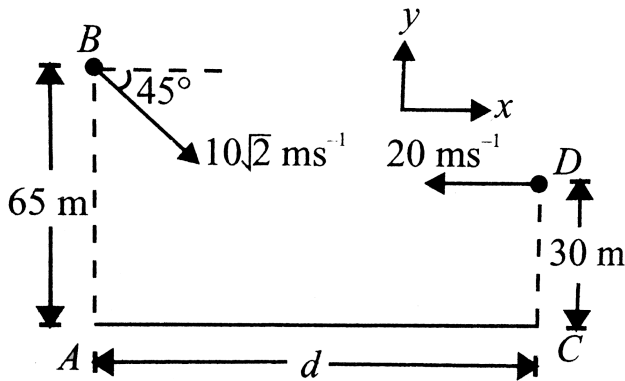

the distance AC is

A. 20 m

B. 30 m

C. $40m$

D. $20m$

Answer: C



Watch Video Solution

65. A ball of mass m is thrown at an angle of 45° to the horizontal,, from the top of a $65m$ high tower AB as shown in Fig. at $t = 0$. Another identical ball is thrown with velocity $20m / s$ horizontally towards AB from the top

of a 30m high tower CD after the projection of the first ball. Both the balls move in the same vertical plane. If they collide in mid-air,

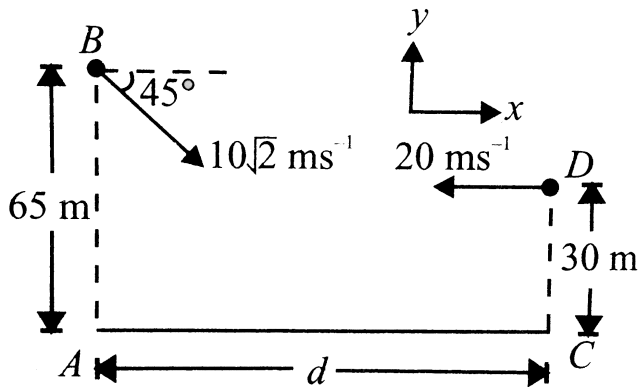

. the velocity of combined ball just after they struck together is

A. $-5i - 20jm / s$

B. $10i - 20jm / s$

C. $-10i - 20jm / s$

D. $-5i + 10jm / s$

Answer: A



Watch Video Solution

66. A ball A of mass m is suspended by a thread of length $r = 1.2m$. Another ball B of mass $2m$ is projected from the ground with velocity $u = 9m / s$ such that at the highest point of its trajectory it collides head-on

elastically with ball A . It is observed that during subsequent motion, tension in the thread at the highest point is equal to mg .

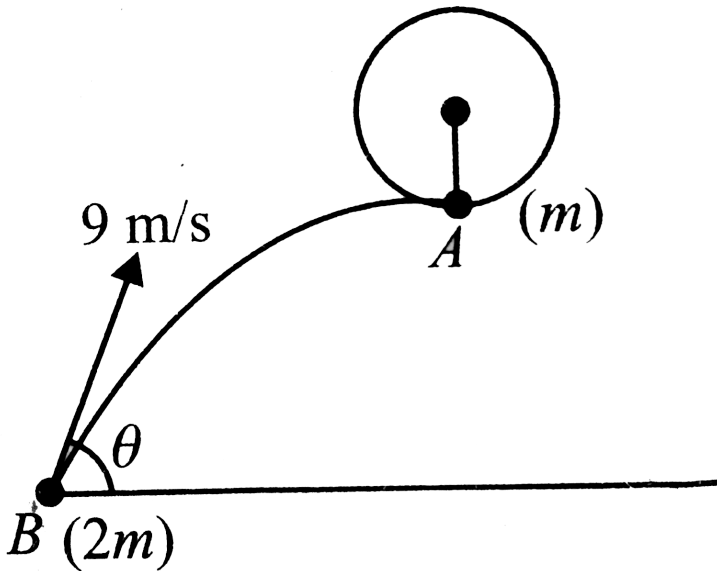

ltrgt At

highest point of B , the velocity of ball A is

A. $6\sqrt{2}m / s$

B. $2\sqrt{6}m / s$

C. $3\sqrt{2}m / s$

D. $3\sqrt{6}m / s$

Answer: A



Watch Video Solution

67. A ball A of mass m is suspended by a thread of length $r = 1.2m$. Another ball B of mass $2m$ is projected from the ground with velocity $u = 9m / s$ such that at the highest point of its trajectory it collides head-on

elastically with ball A . It is observed that during subsequent motion, tension in the thread at the highest point is equal to mg .

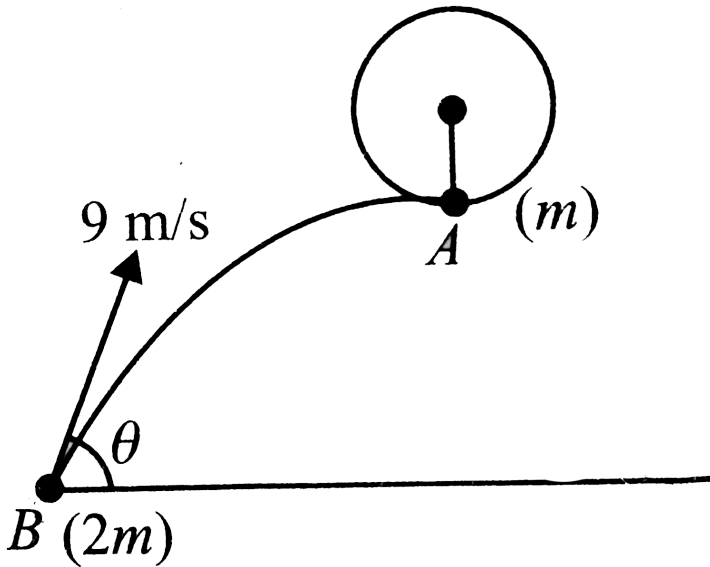

The angle of projection (θ) of ball B is

A. a. 30°

B. 60°

C. 45°

D. 75°

Answer: B



Watch Video Solution

68. A ball A of mass m is suspended by a thread of length $r = 1.2m$. Another ball B of mass $2m$ is projected from the ground with velocity $u = 9m/s$ such that at the highest point of its trajectory it collides head-on

elastically with ball A . It is observed that during subsequent motion, tension in the thread at the highest point is equal to mg .

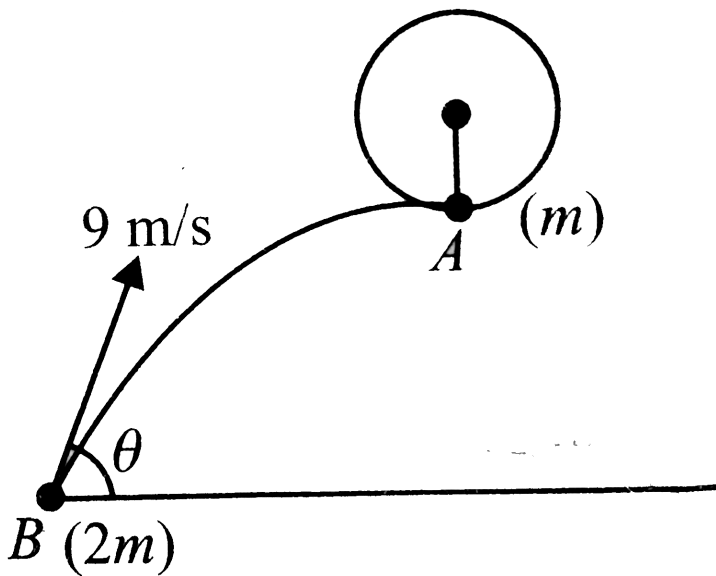

The height of the point of suspension of ball A from the ground is

A. a. $\frac{81}{40}m$

B. $\frac{129}{40}m$

C. $\frac{81}{20}m$

D. $\frac{101}{40}m$

Answer: B



Watch Video Solution

69. Two identical buggies of each of mass 150kg move one after the other friction with same velocity $4\frac{m}{s}$. A man of mass m rides the rear buggy. At a certain moment, the man

jumps into the front buggy with a velocity v relative to his buggy. As a result of this process, real boggy stops. If the sum of kinetic energies of the man and the front buggy just after collision with the from buggy differs from that just before collision by $2700J$ then the mass m of the man is

A. $60kg$

B. $75kg$

C. $50kg$

D. $90kg$

Answer: C

 Watch Video Solution

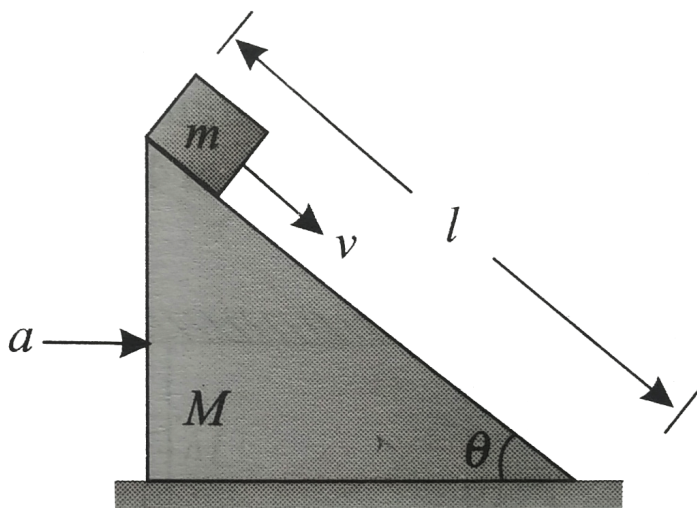

70.

A smooth wedge of mass M is pushed with an acceleration $a = > an\theta$ and a block of mass m is projected down the slant with a velocity v

relative to the wedge.

The horizontal force applied on the wedge is:

A. $16m / s$

B. $8m / s$

C. $10m / s$

D. $15m / s$

Answer: A



Watch Video Solution

71. In the arrangement shown in Fig. the ball and the block have the same mass $m = 1\text{kg}$ each, $\theta = 60^\circ$ and length $l = 2.50\text{m}$. Coefficient of friction between the block and the floor is 0.5. When the ball is released from the position shown in Fig. it collides with the block and the block stops after moving a distance 2.50m .

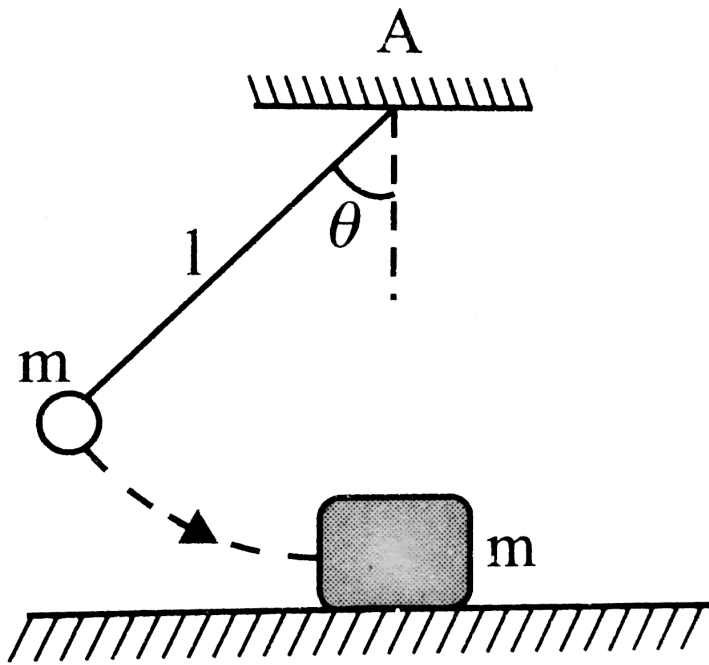

The velocity of block just after collision is

A. a. $10m / s$

B. b. $5m / s$

C. c. $2.5m / s$

D. d. $3m / s$

Answer: B



Watch Video Solution

72. In the arrangement shown in Fig. the ball and the block have the same mass $m = 1\text{kg}$ each, $\theta = 60^\circ$ and length $l = 2.50\text{m}$. Coefficient of friction between the block and the floor is 0.5. When the ball is released from the position shown in Fig. it collides with the block and the block stops after moving a distance 2.50m .

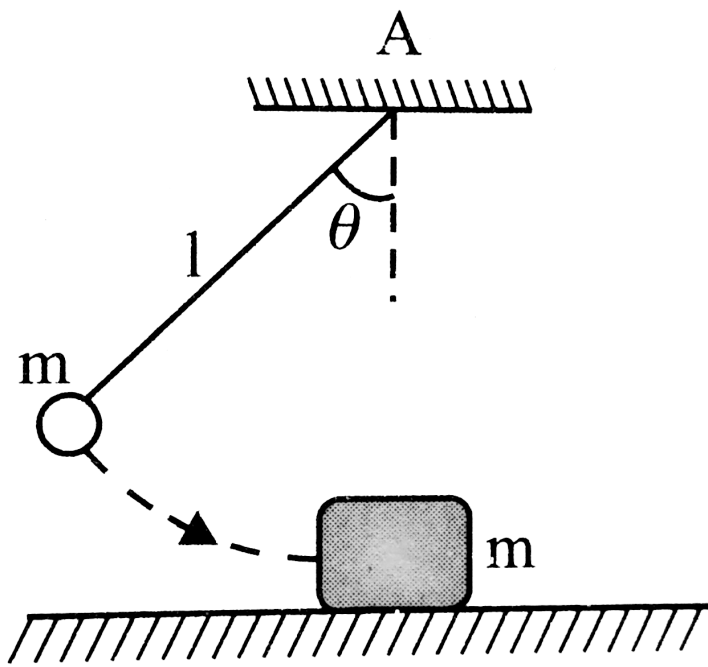

The coefficient of restitution for collision between the ball and the block is

- A. 0.5
- B. 0.75
- C. 1.0

D. 0.3

Answer: C



Watch Video Solution

73. A ball of mass $m = 1\text{kg}$ is hung vertically by a thread of length $l = 1.50\text{m}$. Upper end of the thread is attached to the ceiling of a trolley of mass $M = 4\text{kg}$. Initially, the trolley is stationary and it is free to move along horizontal rails without friction. A shell of

mass $m = 1$ kg, moving horizontally with velocity $v_0 = 6m/s$ collides with the ball and gets stuck with it. As a result, the thread starts to deflect towards right.

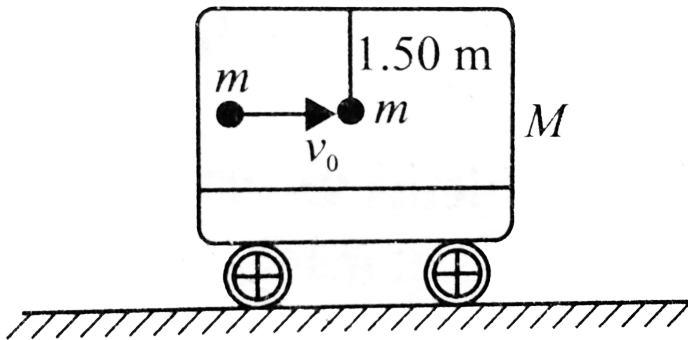

The velocity of the combined body just after collision is

A. $2m/s$

B. $3m/s$

C. $1m / s$

D. $4m / s$

Answer: B



Watch Video Solution

74. A ball of mass $m = 1kg$ is hung vertically by a thread of length $l = 1.50m$. Upper end of the thread is attached to the ceiling of a trolley of mass $M = 4kg$. Initially, the trolley is stationary and it is free to move

along horizontal rails without friction. A shell of mass $m = 1\text{kg}$, moving horizontally with velocity $v_0 = 6\text{m/s}$ collides with the ball and gets stuck with it. As a result, the thread starts to deflect towards right.

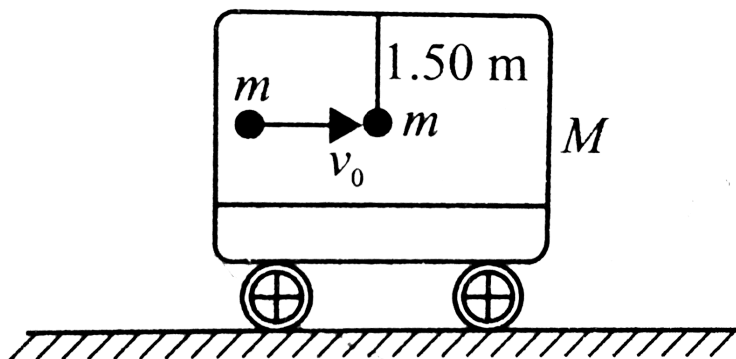

At the time of maximum deflection of the thread with vertical, the trolley will move with velocity

A. a. $2m / s$

B. b. $3m / s$

C. c. $1m / s$

D. d. $4m / s$

Answer: C



Watch Video Solution

75. A ball of mass in $m = 1kg$ is hung vertically by a thread of length $l = 1.50m$. Upper end of the thread is attached to the ceiling of a

trolley of mass $M = 4\text{kg}$. Initially, the trolley is stationary and it is free to move along horizontal rails without friction. A shell of mass $m = 1\text{kg}$, moving horizontally with velocity $v_0 = 6\text{m/s}$ collides with the ball and gets stuck with it. As a result, the thread starts to deflect towards right.

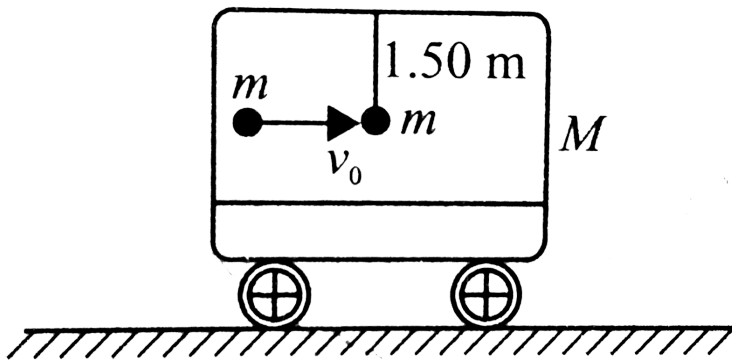

At the time of maximum deflection of the

thread with vertical, the trolley will move with velocity

A. $\cos^{-1}\left(\frac{4}{5}\right)$

B. $\cos^{-1}\left(\frac{3}{5}\right)$

C. $\cos^{-1}\left(\frac{2}{3}\right)$

D. $\cos^{-1}\left(\frac{3}{4}\right)$

Answer: A



Watch Video Solution

76. Two balls of masses $m_1 = 100g$ and $m_2 = 300g$ are suspended from point A by two equal inextensible threads, each of length $l = \frac{32}{35}m$. Ball of mass m_1 is drawn aside and held at the same level as A but at a distance $\left(\frac{\sqrt{3}}{2}\right)l$ from A , as shown in Fig. When ball m_1 is released, it collides elastically with the stationary ball of mass m_2 .

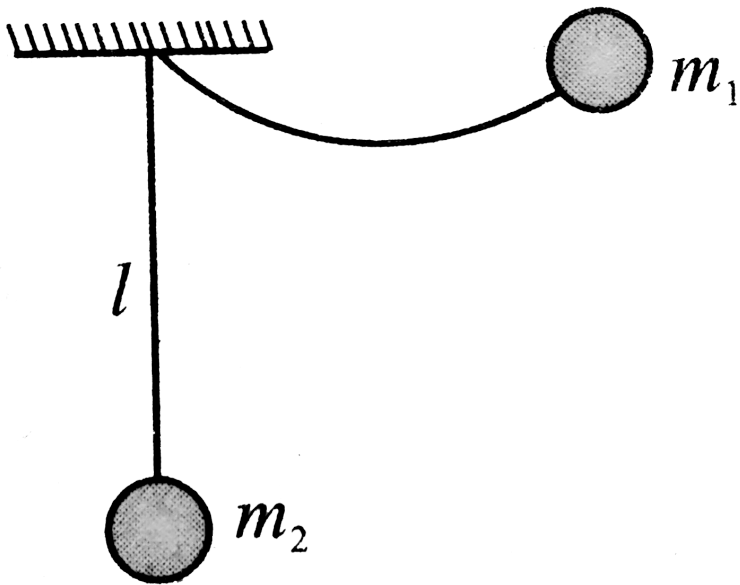

Velocity u_1 with which the ball of mass m_1 collides with the other ball is

- A. $1m / s$
- B. $2m / s$
- C. $3m / s$

D. $4m / s$

Answer: D



Watch Video Solution

77. Two balls of masses $m_1 = 100g$ and $m_2 = 300g$ are suspended from point A by two equal inextensible threads, each of length $l = \frac{32}{35}m$. Ball of mass m_1 is drawn aside and held at the same level as A but at a distance $\left(\frac{\sqrt{3}}{2}\right)l$ from A , as shown in Fig. When ball

m_1 is released, it collides elastically with the stationary ball of mass m_2 .

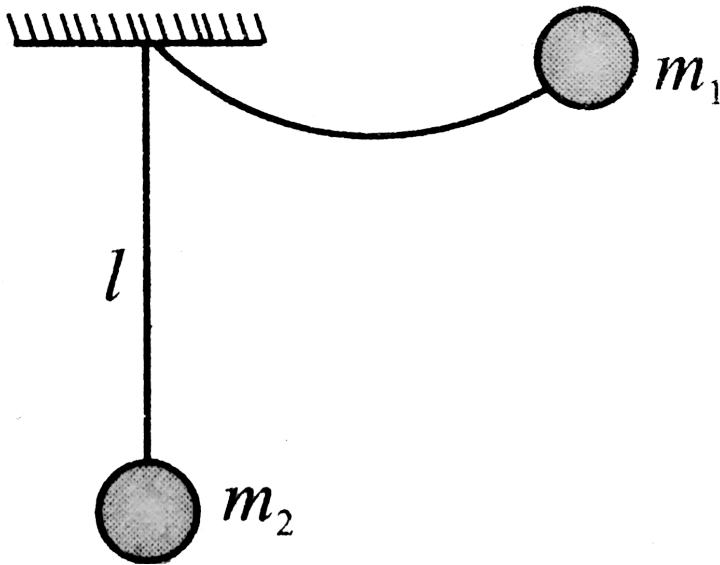

The
maximum rise of centre of mass of the ball of
mass m_2 is

A. a. $0.20m$

B. b. $0.50m$

C. c. $0.75m$

D. d. $1m$

Answer: A



Watch Video Solution

78. Two identical blocks A and B each of mass $2kg$ are hanging stationary by a light inextensible flexible string, passing over a light and frictionless pulley, as shown in Fig. A shell C of mass $1kg$ moving vertically upwards with

velocity $9m/s$ collides with block B and gets stuck to it.

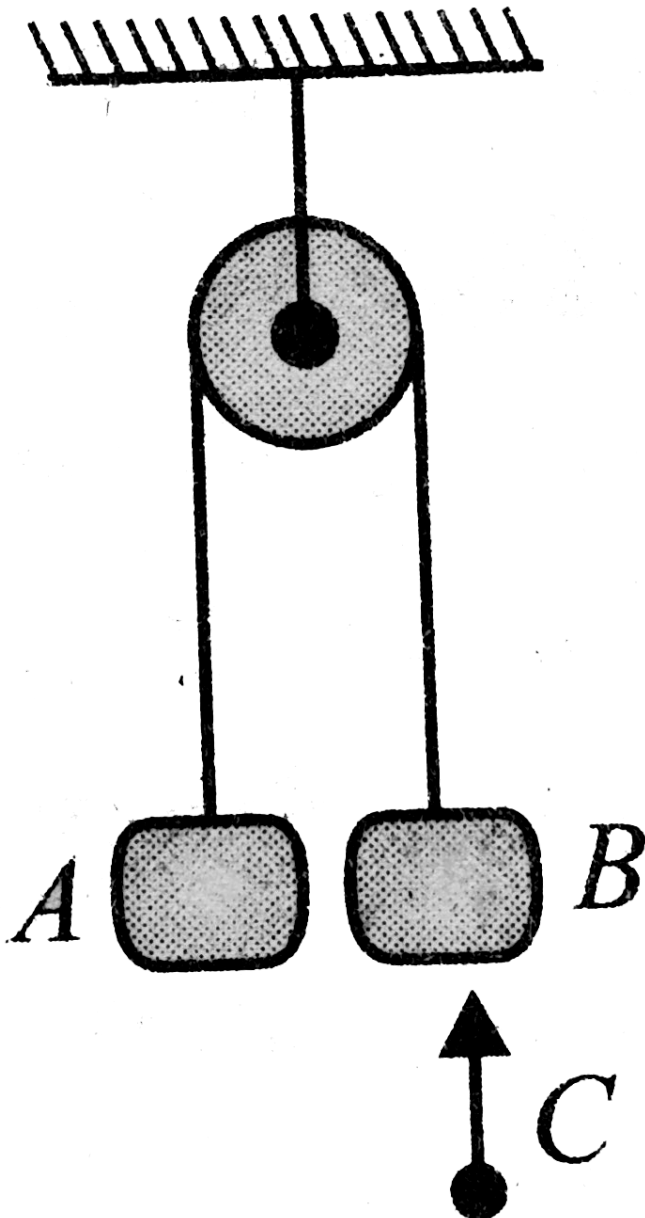

Calculate the time after which block B starts moving downwards.

A. $0.90s$

B. $1s$

C. $0.60s$

D. $0.30s$

Answer: A



Watch Video Solution

79. Two identical blocks A and B each of mass 2kg are hanging stationary by a light inextensible flexible string, passing over a light and frictionless pulley, as shown in Fig. A shell C of mass 1kg moving vertically upwards with velocity 9m/s collides with block B and gets stuck to it.

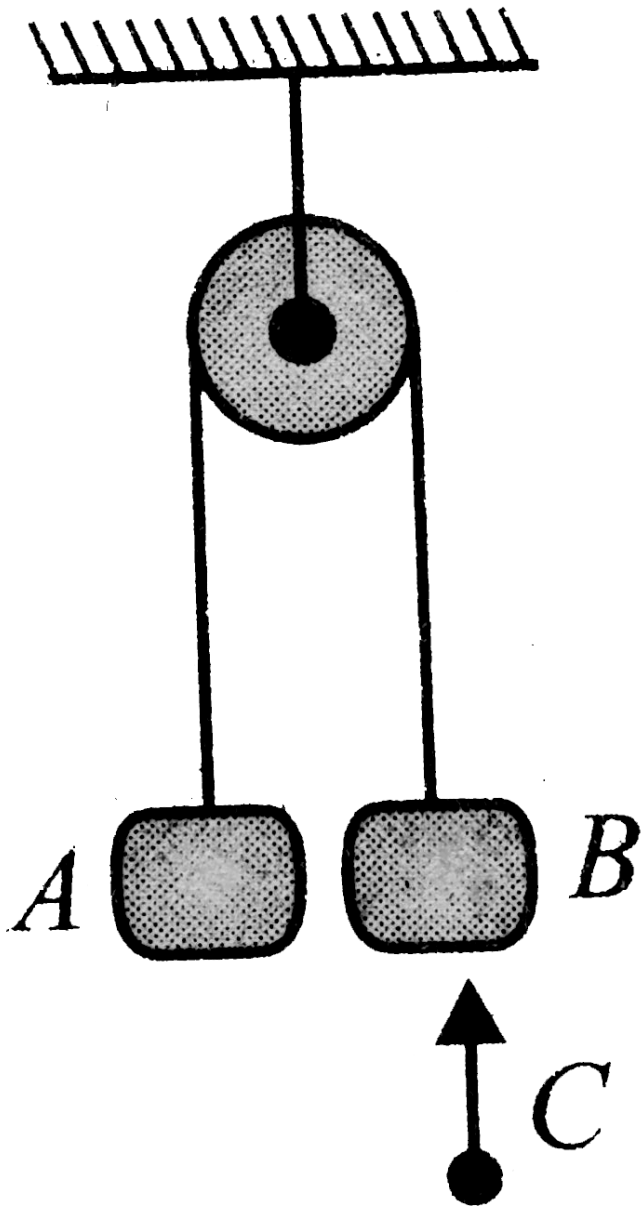

The maximum height reached by B

A. $0.81m$

B. $0.36m$

C. $0.49m$

D. $0.25m$

Answer: A



Watch Video Solution

80. Two identical blocks A and B each of mass $2kg$ are hanging stationary by a light inextensible flexible string, passing over a light

and frictionless pulley, as shown in Fig. A shell C of mass 1kg moving vertically upwards with velocity 9m/s collides with block B and gets stuck to it.

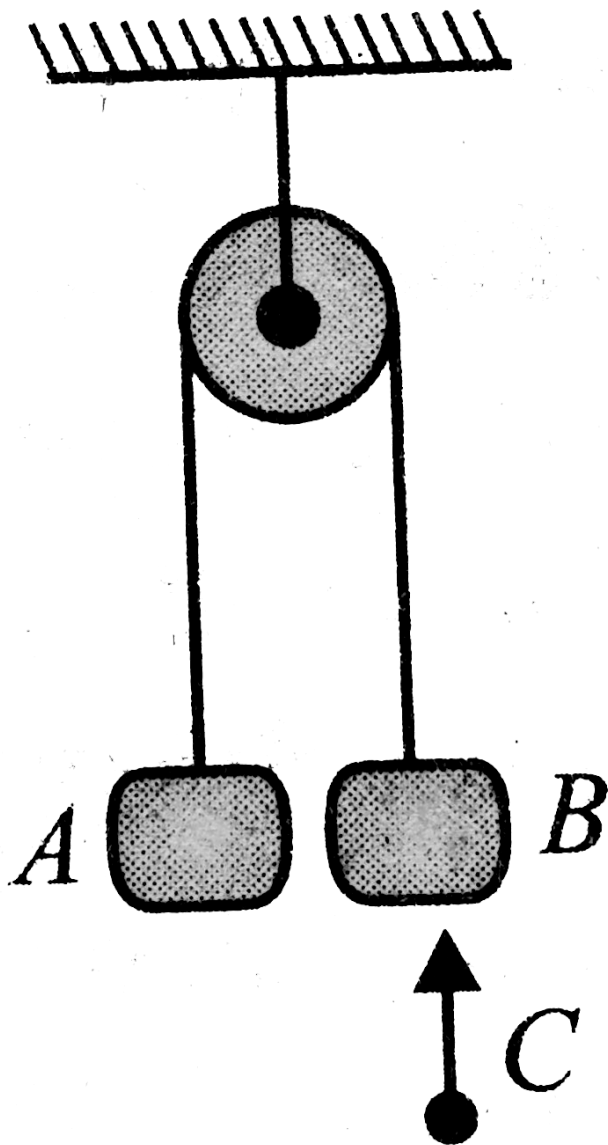

The loss of mechanical energy up to that instant is

A. $32.4J$

B. $40J$

C. $16.5J$

D. $12.5J$

Answer: A



Watch Video Solution

81. A pan of mass $m = 1.5kg$ and a block of mass $M = 3kg$ are connected to each other by a light inextensible string, passing over a

light pulley as shown in Fig. Initially, the block is resting on a horizontal floor. A ball of mass $m_0 = 0.5\text{kg}$ collides with the pan at a speed $v_0 = 20\text{m/s}$. Consider this instant of collision as $t = 0$. Assume collision to be perfectly inelastic. Now, Fig. answer the following questions based on the above information.

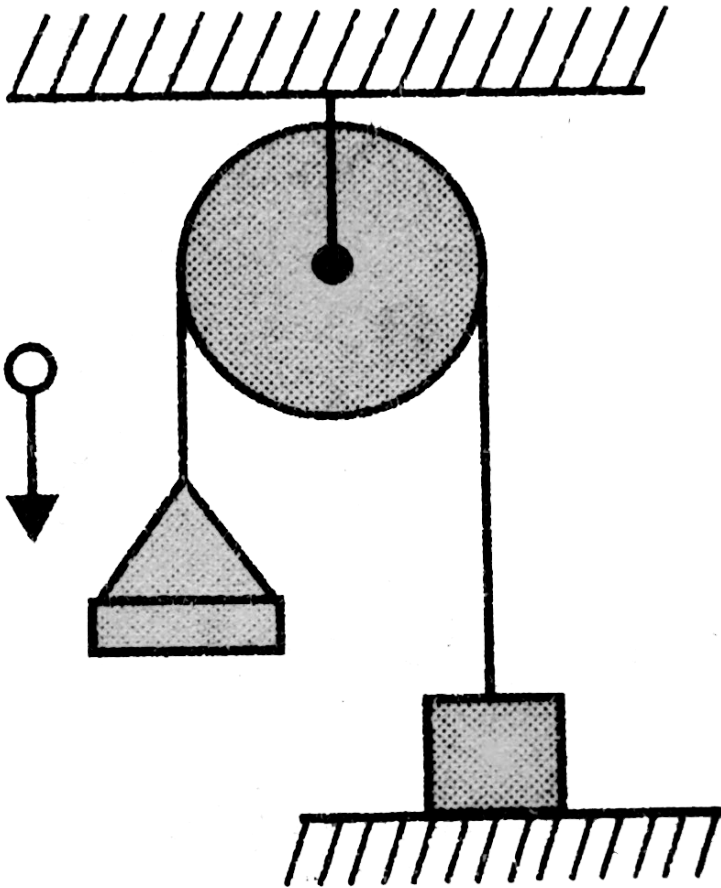

Mark the correct statement(s) for this situation

A. After the collision, the pan + ball system moves downwards with decreasing speed.

B. After the collision, the block is moving upwards with the same speed with - which the ball + pan system is moving downwards

C. The block will jerk for a number of times during its motion.

D. All of these

Answer: D



Watch Video Solution

82. A pan of mass $m = 1.5\text{kg}$ and a block of mass $M = 3\text{kg}$ are connected to each other by a light inextensible string, passing over a light pulley as shown in Fig. Initially, the block is resting on a horizontal floor. A ball of mass $m_0 = 0.5\text{kg}$ collides with the pan at a speed $v_0 = 20\text{m/s}$. Consider this instant of collision as $t = 0$. Assume collision to be perfectly

inelastic. Now, Fig. answer the following questions based on the above information.

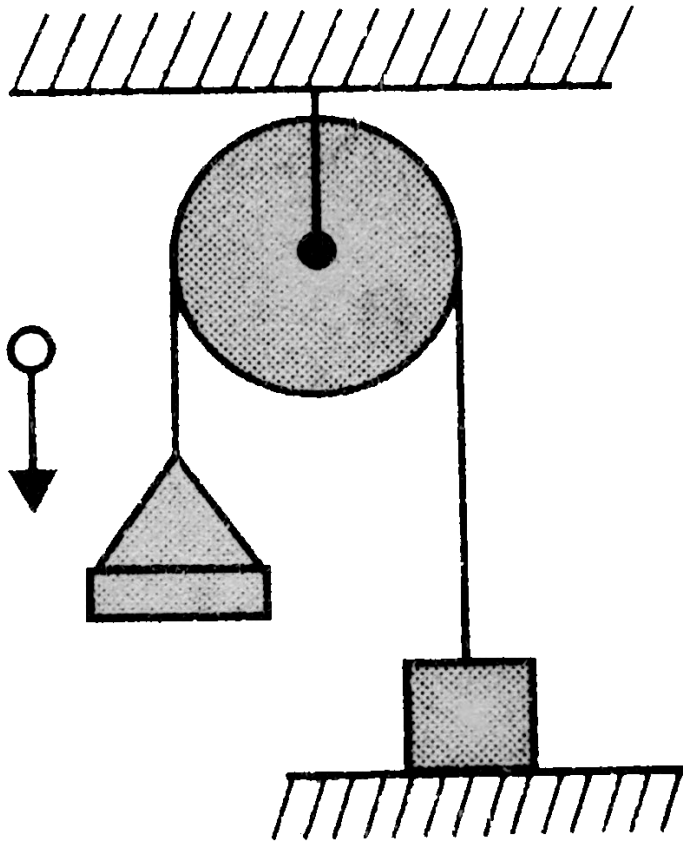

Find the time t at which the block strikes the floor for the first time

A. $1s$

B. 2

C. $4s$

D. $5s$

Answer: B



Watch Video Solution

83. A pan of mass $m = 1.5kg$ and a block of mass $M = 3kg$ are connected to each other by a light inextensible string, passing over a

light pulley as shown in Fig. Initially, the block is resting on a horizontal floor. A ball of mass $m_0 = 0.5\text{kg}$ collides with the pan at a speed $v_0 = 20\text{m/s}$. Consider this instant of collision as $t = 0$. Assume collision to be perfectly inelastic. Now, Fig. answer the following questions based on the above information.

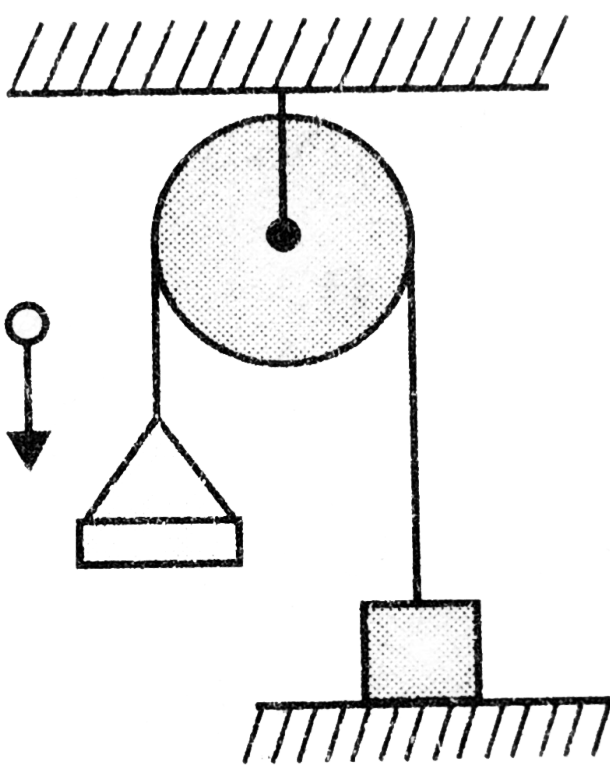

Find the velocity of pan + ball system at $t = 2.6s$. Assume that the block comes to rest instantaneously after striking the floor.

A. $4m / s$ downward

B. $4m / s$ upward

C. $0.6m / s$ upward

D. $0.4m / s$ downward

Answer: D



Watch Video Solution

84. A pan of mass $m = 1.5kg$ and a block of mass $M = 3kg$ are connected to each other by a light inextensible string, passing over a light pulley as shown in Fig. Initially, the block is resting on a horizontal floor. A ball of mass

$m_0 = 0.5\text{kg}$ collides with the pan at a speed $v_0 = 20\text{m/s}$. Consider this instant of collision as $t = 0$. Assume collision to be perfectly inelastic. Now, Fig. answer the following questions based on the above information.

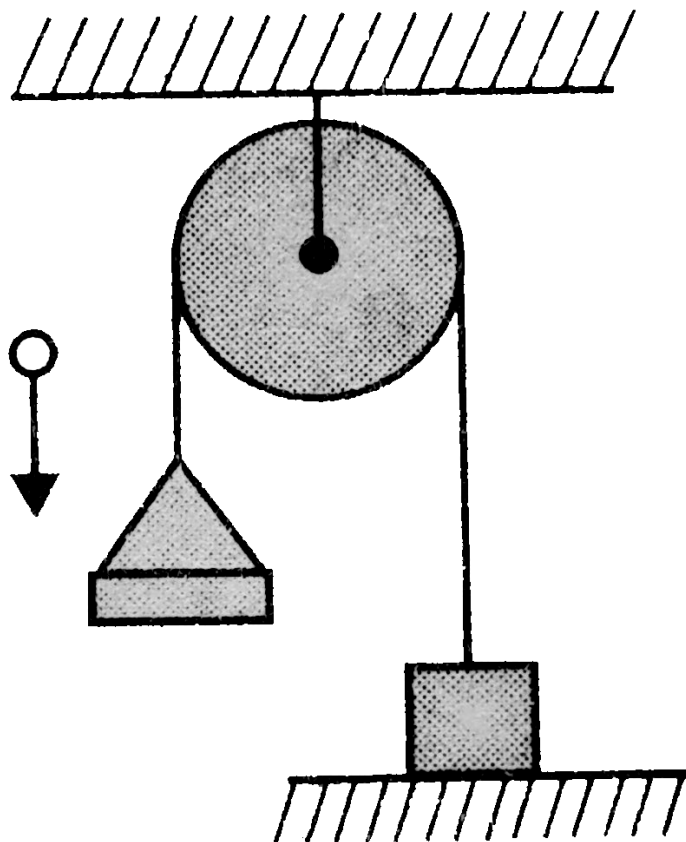

Find the time t at which the block strikes the floor for the first time

A. $0.2m$

B. $0.64m$

C. $0.16m$

D. No jerk for the second time

Answer: C



Watch Video Solution

85. A horizontal frictionless rod is threaded through a bead of mass m . The length of the cart is L and the radius of the bead, r , is very small in comparison with L ($r \ll L$). Initially at ($t = 0$) the bead is at the right edge of the cart. The cart is struck and as a result, it moves with velocity v_0 towards right. When the bead collides with the cart's walls, the collisions are always completely elastic.

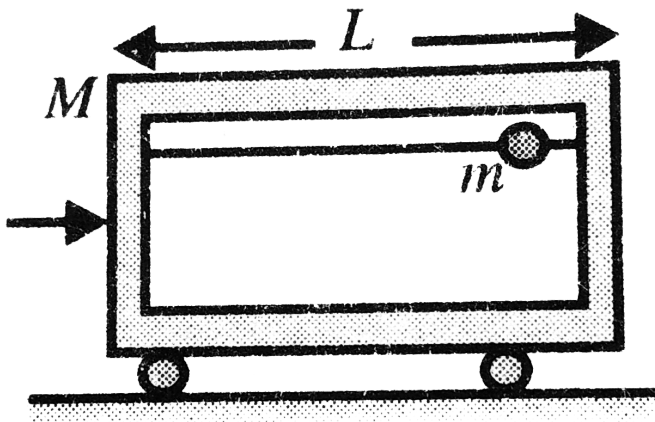

What is the velocity of the cart just after the first collision?

A. $\frac{-mv_0}{m + M}$

B. $\frac{Mv_0}{m + M}$

C. $\frac{M - m}{M + m}v_0$

D. $\frac{2M}{m + M}v_0$

Answer: C



Watch Video Solution

86. A horizontal frictionless rod is threaded through a bead of mass m . The length of the cart is L and the radius of the bead, r , is very small in comparison with L ($r \ll L$). Initially at ($t = 0$) the bead is at the right edge of the cart. The cart is struck and as a result, it moves with velocity v_0 towards right. When the bead collides with the cart's walls, the

collisions are always completely elastic.

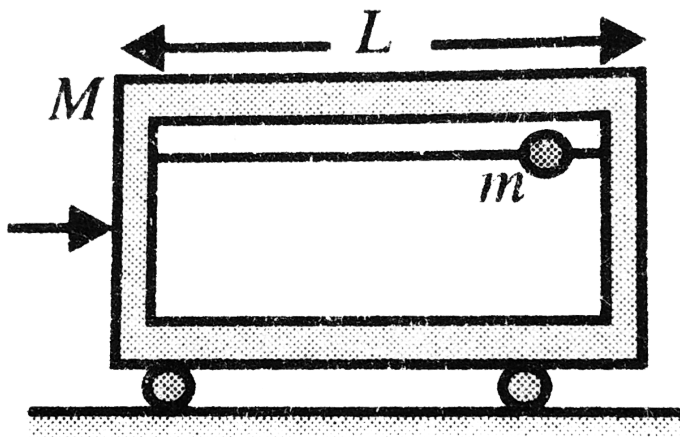

Velocity of bead just after the first collision is

- A. $\frac{-mv_0}{m+M}$
- B. $\frac{Mv_0}{m+M}$
- C. $\frac{M-m}{M+m}v_0$
- D. $\frac{2M}{m+M}v_0$

Answer: D



Watch Video Solution

87. A horizontal frictionless rod is threaded through a bead of mass m . The length of the cart is L and the radius of the bead, r , is very small in comparison with L ($r \ll L$). Initially at ($t = 0$) the bead is at the right edge of the cart. The cart is struck and as a result, it moves with velocity v_0 towards right. When the bead collides with the cart's walls, the

collisions are always completely elastic.

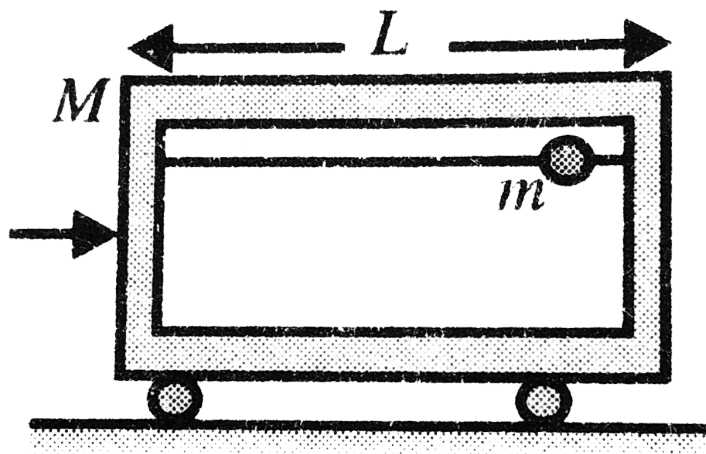

The first collision takes place at time t_1 and the second collision takes place at time t_2 . Find

$$t_2 - t_1$$

A. $\frac{2L}{v_0}$

B. $\frac{L}{v_0}$

C. $\frac{L}{2v_0}$

D. $\frac{L}{3v_0}$

Answer: B



Watch Video Solution

88. An initially stationary box on a frictionless floor explodes into two pieces, piece A with mass m_A and piece B with mass m_B . Two pieces then move across the floor along x -axis. Graph of position versus time for the two pieces are given

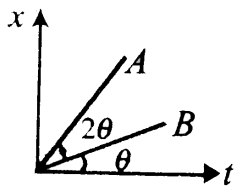

(I)

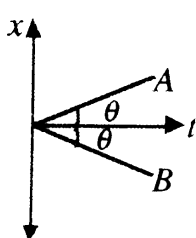

(II)

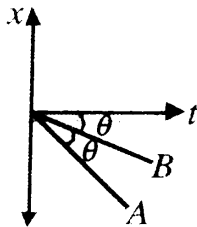

(III)

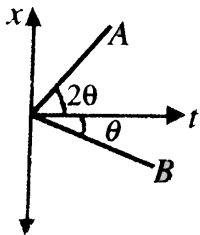

(IV)

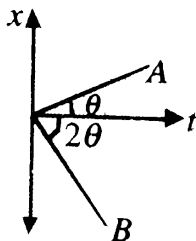

(V)

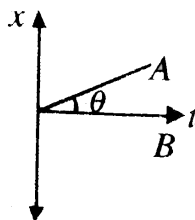

(VI)

Which graphs pertain to physically possible explosion?

A. II,IV,V

B. I,III,VI

C. I,III,V

D. II,III,VI

Answer: A



Watch Video Solution

89. An initially stationary box on a frictionless floor explodes into two pieces, piece A with mass m_A and piece B with mass m_B . Two pieces then move across the floor along x -axis. Graph of position versus time for the two pieces are given

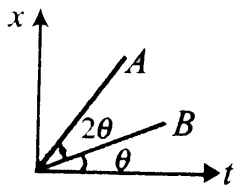

(I)

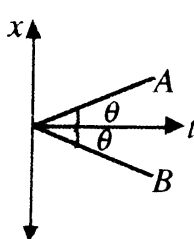

(II)

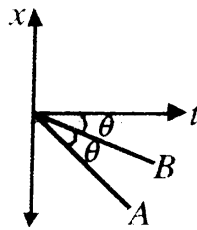

(III)

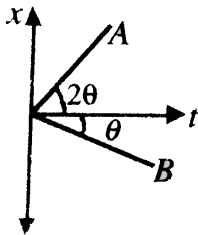

(IV)

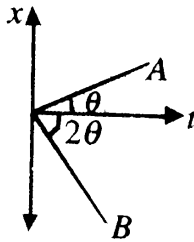

(V)

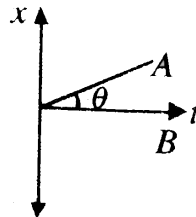

(VI)

Which graphs pertain to physically possible explosion?

- A. II
- B. IV
- C. V
- D. VI

Answer: D



Watch Video Solution

90. A circular disc of mass ' $2m$ ' and radius ' $3r$ ' is resting on a flat frictionless surface. Another circular disc of mass m and radius ' $2r$ ', moving with a velocity ' u ', hits the first disc as shown in the figure. The collision is elastic.

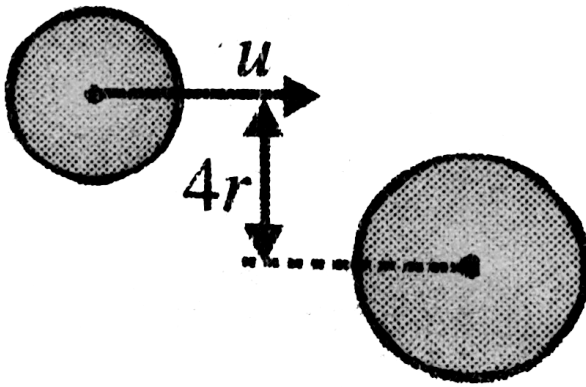

What is the tangential component of final velocity of the smaller disc?

A. u

B. $\frac{u}{2}$

C. $\frac{3u}{2}$

D. $\frac{4u}{5}$

Answer: D



Watch Video Solution

91. A circular disc of mass ' $2m$ ' and radius ' $3r$ ' is resting on a flat frictionless surface. Another circular disc of mass m and radius ' $2r$ ', moving with a velocity ' u ', hits the first disc as shown in the figure. The collision is elastic.

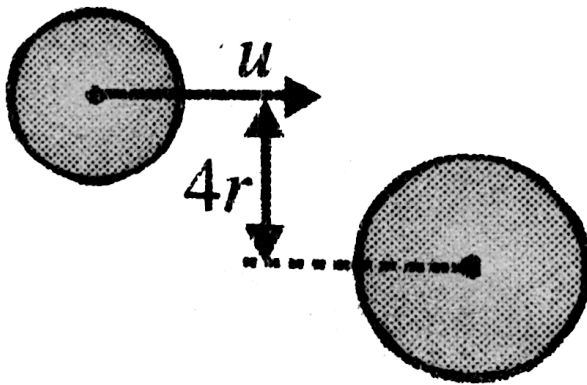

What is the tangential component of final velocity of the smaller disc?

- A. $\frac{u}{5}$
- B. $\frac{2u}{5}$
- C. $\frac{3u}{5}$
- D. $\frac{4u}{5}$

Answer: A



Watch Video Solution

92. A circular disc of mass ' $2m$ ' and radius ' $3r$ ' is resting on a flat frictionless surface. Another circular disc of mass m and radius ' $2r$ ', moving with a velocity ' u ', hits the first disc as shown in the figure. The collision is elastic.

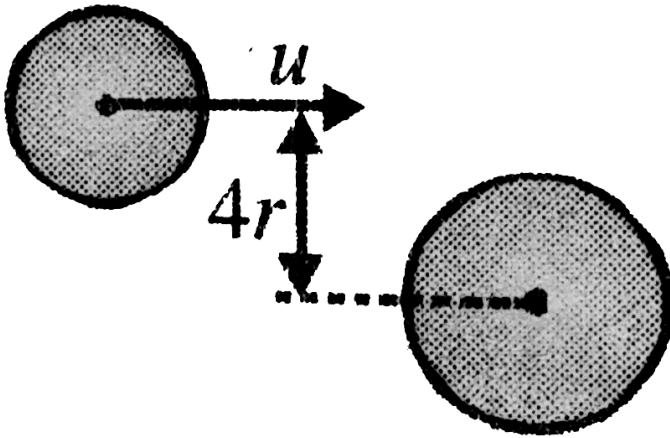

What is

the final velocity of the heavier disc?

- A. a. $\frac{u}{5}$
- B. b. $\frac{2u}{5}$
- C. c. $\frac{3u}{5}$
- D. d. $\frac{4u}{5}$

Answer: B



Watch Video Solution

93. Two blocks of masses m_1 and m_2 are connected by an ideal spring, of force constant k . The blocks are placed on smooth horizontal surface. A horizontal force F acts on the block m_1 . Initially spring is relaxed, both the blocks are at rest.



What is acceleration of centre of mass of system at the instant of maximum elongation of spring

A. a. zero

B. b. $n \frac{F(m_1 + m_2)}{m_1 m_2}$

C. c. $\frac{F}{m_1}$

D. d. $\frac{F}{m_1 + m_2}$

Answer: D



Watch Video Solution

94. Two blocks of masses m_1 and m_2 are connected by an ideal spring, of force constant k . The blocks are placed on smooth horizontal

surface. A horizontal force F acts on the block m_1 . Initially spring is relaxed, both the blocks are at rest.

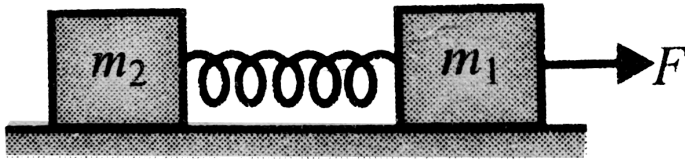

Which of the following statement is not true in the case of above system.

A. a. Centre of mass reference frame is an inertial frame.

B. b. Kinetic energy of the system is minimum in centre of mass frame.

C. c. At the instant of maximum deformation both the blocks are instantaneously at rest in centre of mass reference frame

D. d. Acceleration of centre of mass is constant in ground frame.

Answer: A



Watch Video Solution

95. A block of mass m is connected to another block of mass M by a massless spring of spring constant k . The blocks are kept on a smooth horizontal plane and are at rest. The spring is unstretched when a constant force F starts acting on the block of mass M to pull it. Find the maximum extension of the spring

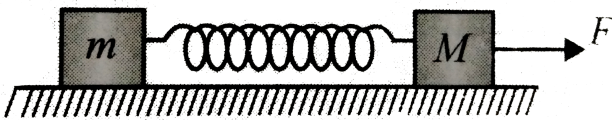

- A. $\frac{2m_1 F}{(m_1 + m_2)k}$
- B. $\frac{m_1^2 F}{2(m_1 + m_2)k}$

C.
$$\frac{2m_2F}{k(m_1 + m_2)}$$

D.
$$\frac{m_2^2F}{2(m_1 + m_2)^2k}$$

Answer: C



Watch Video Solution

96. A small ball B of mass m is suspended with light inelastic string of length L from a block A of same mass in which can move on smooth horizontal surface as shown in the figure. The ball is displaced by angle θ from equilibrium

position and then released.

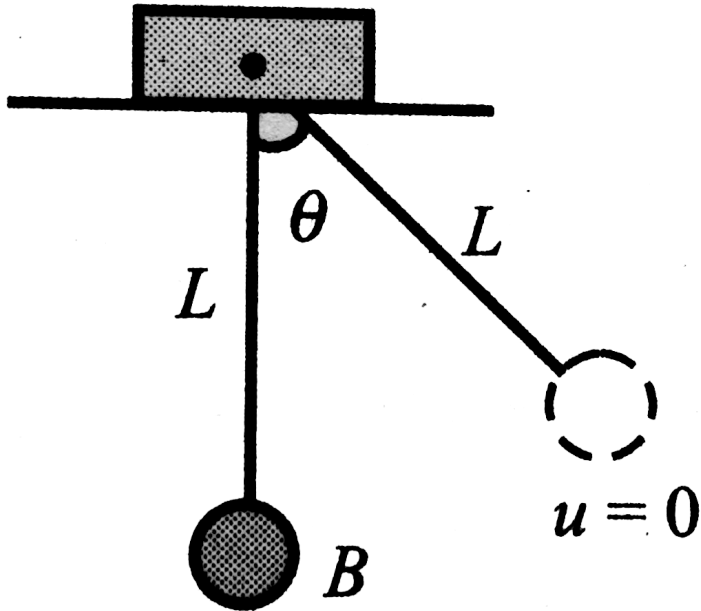

The displacement of block when equilibrium position is

A. $\frac{L \sin \theta}{2}$

B. $L \sin \theta$

C. L

D. none of these

Answer: A



Watch Video Solution

97. A small ball B of mass m is suspended with light inelastic string of length L from a block A of same mass in which can move on smooth horizontal surface as shown in the figure. The ball is displaced by angle θ from equilibrium position and then released.

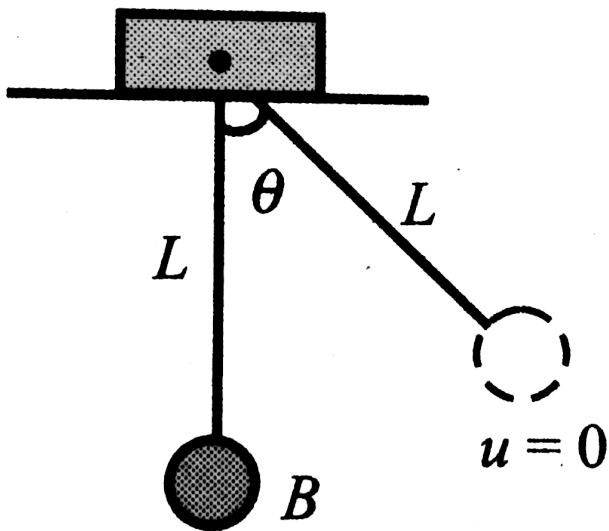

Tension in string when it is vertical, is

A. mg

B. $mg(2 - \cos \theta)$

C. $mg(3 - 2 \cos \theta)$

D. none of these

Answer: D



Watch Video Solution

98. A small ball B of mass m is suspended with light inelastic string of length L from a block A of same mass in which can move on smooth horizontal surface as shown in the figure. The ball is displaced by angle θ from equilibrium position and then released.

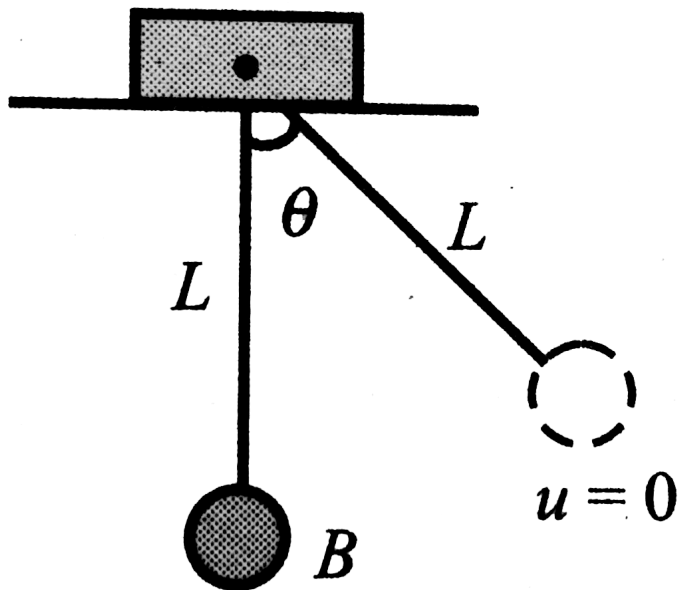

Maximum velocity of block during subsequent motion of the system after release of ball is

- A. $[gl(1 - \cos \theta)]^{\frac{1}{2}}$
- B. $[2gl(1 - \cos \theta)]^{\frac{1}{2}}$
- C. $[gl \cos \theta]^{\frac{1}{2}}$

D. information are sufficient to decide

Answer: A



Watch Video Solution

99. A small ball B of mass m is suspended with light inelastic string of length L from a block A of same mass in which can move on smooth horizontal surface as shown in the figure. The ball is displaced by angle θ from equilibrium position and then released.

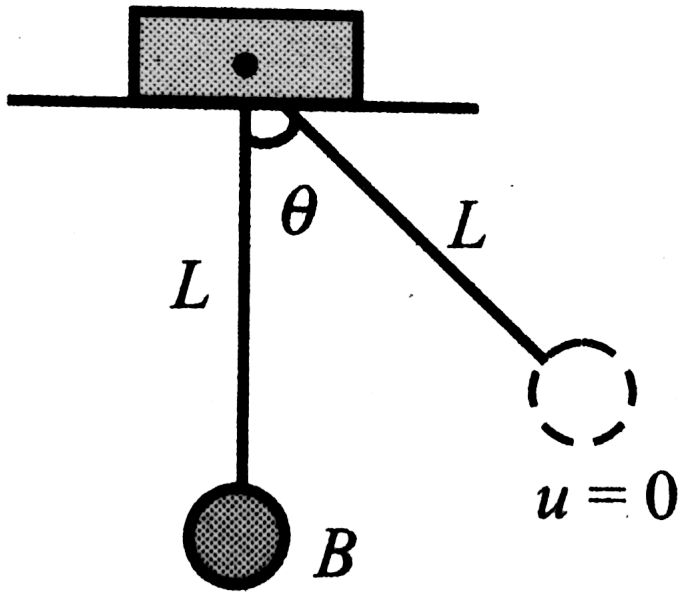

The

displacement of centre of mass of $A + B$ system till the string becomes vertical is

A. zero

B. $L(1 - \cos \theta)$

C. $\frac{L}{2}(1 - \cos \theta)$

D. none of these

Answer: C



Watch Video Solution

100. A small ball of mass 1kg is kept in circular path of radius 1m inside a concentric smooth horizontal fixed casing of radius R . Angular speed of the ball in the circular motion is 1rads^{-1} . At a certain moment the string, which kept the ball in the circular path breaks

and the ball goes off tangentially to the wall of rigid casing and bounces off elastically and again hits the casing and bounces off. This way, the ball traces a regular hexagon. Consider all the collisions to be elastic.

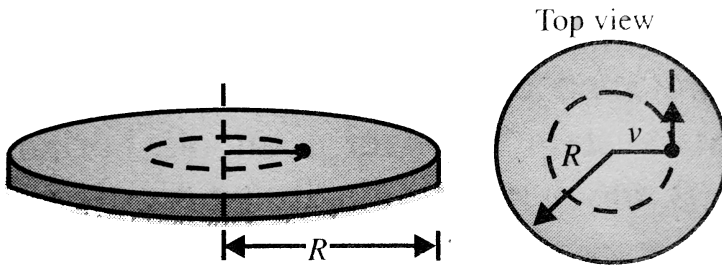

Total time between the first collision and the seventh collision will

A. $6\sqrt{3}Ns$

B. $3\sqrt{3}Ns$

C. zero

D. $12Ns$

Answer: C



Watch Video Solution

101. A small ball of mass $1kg$ is kept in circular path of radius $1m$ inside a concentric smooth horizontal fixed casing of radius R . Angular speed of the ball in the circular motion is $1rads^{-1}$. At a certain moment the string,

which kept the ball in the circular path breaks and the ball goes off tangentially to the wall of rigid casing and bounces off elastically and again hits the casing and bounces off. This way, the ball traces a regular hexagon. Consider all the collisions to be elastic.

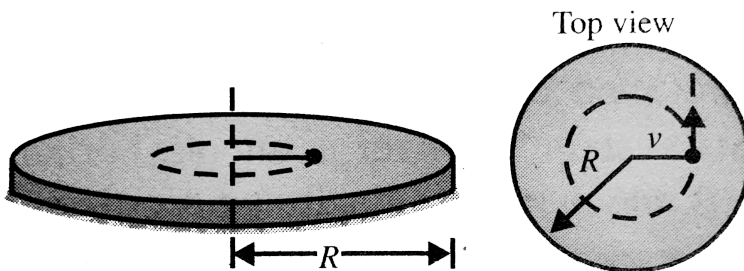

Following quantities of the ball will remain a constant before and after any collision

- A. linear momentum

B. kinetic energy, angular momentum about
the centre of the circle

C. velocity, angular momentum about the
centre of the circle, kinetic energy

D. none of these

Answer: B



Watch Video Solution

102. A small ball of mass $1kg$ is kept in circular path of radius $1m$ inside a concentric smooth horizontal fixed casing of radius R . Angular speed of the ball in the circular motion is $1rads^{-1}$. At a certain moment the string, which kept the ball in the circular path breaks and the ball goes off tangentially to the wall of rigid casing and bounces off elastically and again hits the casing and bounces off. This way, the ball traces a regular hexagon. Consider all the collisions to be elastic.

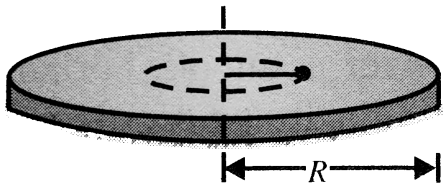

Top view

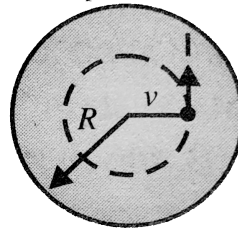

Total time between the first collision and the seventh collision will

A. $\frac{\sqrt{4}}{3} s$

B. $4\sqrt{3} s$

C. $3\sqrt{3} s$

D. none

Answer: B



Watch Video Solution

103. Three balls A , B and C ($m_A = m_C = 4m_B$) are placed on a smooth horizontal surface. Ball B collides with ball C with an initial velocity v as shown in figure. Find the total number of collision between the balls (all collisions are elastic).

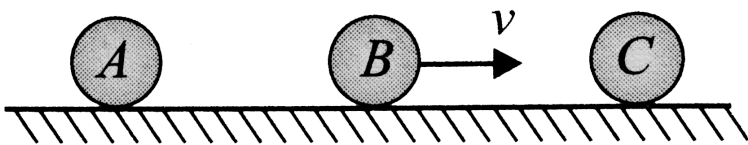

Watch Video Solution

104. A man standing on a trolley pushes another identical trolley (both trolleys are at rest on a rough surface), are set in motion and stop after some time so that they If the ratio of mass of first trolley with man to mass of second trolley is 3, then find the ratio of the stopping distances of the second trolley to that of the first trolley. (Assume coefficient of friction to be the same for both the trolleys)



Watch Video Solution

105. A particle with a mass of 1kg a velocity of 10m/s in $+ve x$ -direction at $t = 0$. Forces \vec{F}_1 and \vec{F}_2 , act on the particle whose magnitudes are changing with time according to the variation shown in Fig. The magnitude of the velocity of the particle at $t = 3\text{s}$ (neglect gravity effect) is found to be $n\sqrt{5}$ Find the value of n

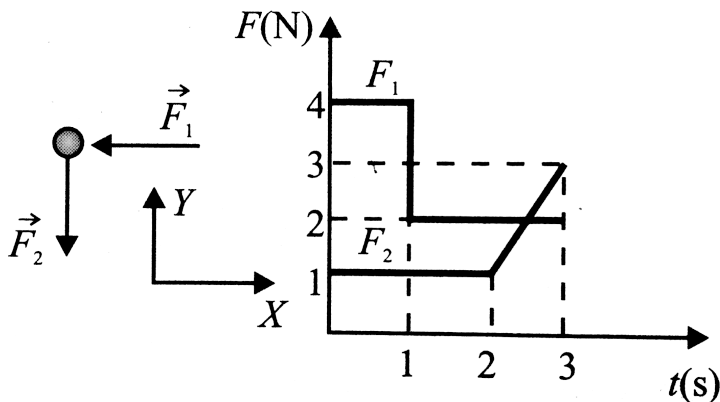



Watch Video Solution

Integer

1. A bullet is fired on a fixed target. It penetrates inside the target through distance $d = 3.75\text{cm}$ and then stops. mass of the bullet is $m = 1\text{kg}$ and of the target is $M = 4\text{kg}$. Now an identical bullet moving with the same velocity is fired on the identical target which is placed at rest on a frictionless horizontal

surface. Then find the distance (in cm) to which the bullet will penetrate inside the target?



[Watch Video Solution](#)

2. A frog sits on the end of a long board of length L . The board rests on a frictionless horizontal table. The frog wants to take off with the minimum speed v relative to ground that allows the frog to do the trick. The board and the frog have equal masses.



[Watch Video Solution](#)

3. A ball of mass 1 kg moving with a velocity of 5 m/s collides elastically with rough ground at an angle θ with the vertical as shown in Fig. What can be the minimum coefficient of friction if ball rebounds vertically after collision? (given $\tan \theta = 2$)

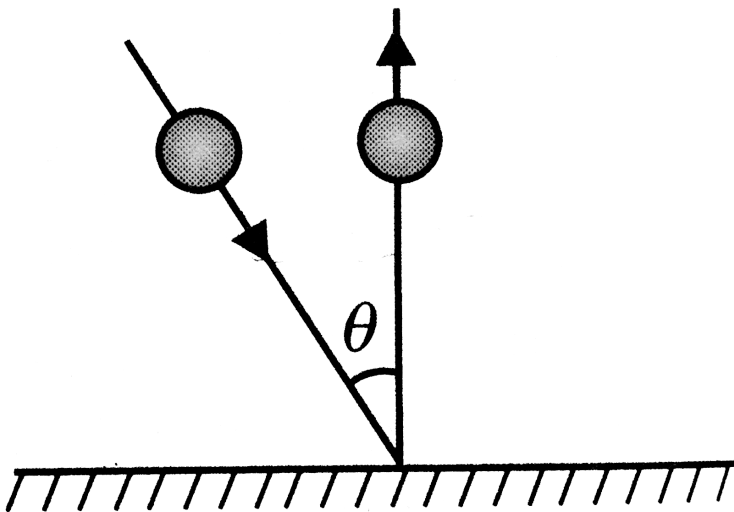



[Watch Video Solution](#)

4. A small sphere of mass $m = 1\text{kg}$ is moving with a velocity $(4\hat{i} - \hat{j})\text{m/s}$. It hits a fixed smooth wall and rebounds with velocity $(\hat{i} + 3\hat{j})\text{m/s}$. The coefficient of restitution between the sphere and the wall is $n/16$. Find the value of n .



[Watch Video Solution](#)

5. A child of mass $4kg$ jumps from cart B to cart A and then immediately back to cart B . The mass of each cart is $20kg$ and they are initially at rest. In both the cases the child jumps at $6m/s$ relative to the cart. If the cart moves along the same line with negligible friction with the final velocities of V_B and V_A , respectively, find the ratio of $6V_B$ and $5v_A$.

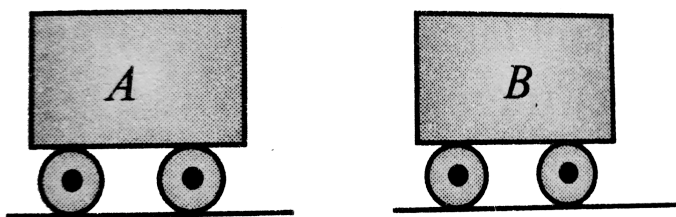

Watch Video Solution

6. A man of mass $M = 58\text{kg}$ jumps from an aeroplane as shown in Fig. He sees the hard ground below him and a lake at a distance $d = 1\text{m}$ from the point directly below him. He immediately puts off his jacket (mass $m = 2\text{kg}$) and throws it in a direction directly away from the lake. If he just fails to strike the ground, find the distance (in 10^1m) he should walk now to pick his jacket. (Neglect air resistance and take the velocity of man at the

time of jump with respect to earth zero.)

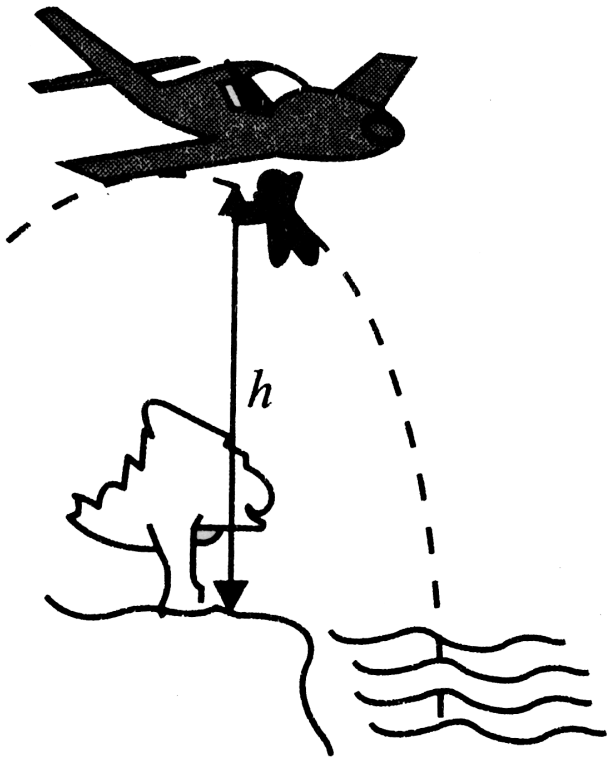

 [Watch Video Solution](#)

7. A ball of mass m makes head-on elastic collision with a ball of mass nm which is initially at rest. Show that the fractional transfer of energy by the first ball is $4\frac{n}{(1+n)^2}$. Deduce the value of n for which the transfer is maximum.



[Watch Video Solution](#)

8. A massless spring of force constant $1000Nm^{-1}$ is compressed a distance of $20cm$

between discs of 8kg and 2kg , spring is not attached to discs. The system is given an initial velocity 3ms^{-1} perpendicular to length of spring as shown in the figure. What is ground frame velocity of 2kg block (in ms^{-1}) when spring regains its natural length.

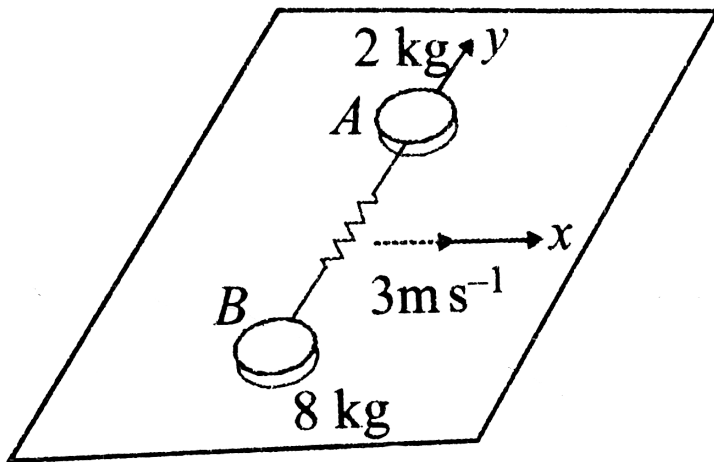

[Watch Video Solution](#)

9. Figure shows position and velocities of two particles moving under mutual gravitational attraction in space at time $t = 0$. The position of centre of mass after one second is

'*' m . Fill '*'.

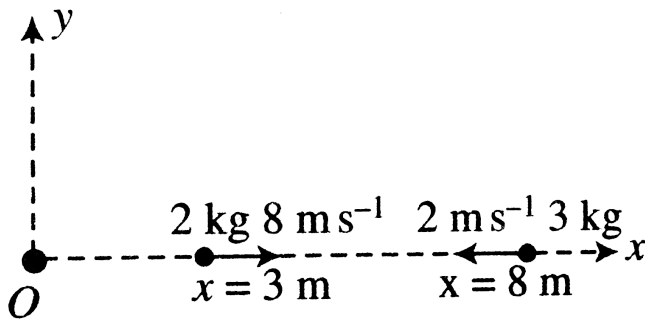

[Watch Video Solution](#)

10. Three particles A , B and C of equal mass move with equal speed $V = 5\text{ms}^{-1}$ along the medians of an equilateral triangle as shown in the figure. They collide at the centroid G of the triangle. After the collision, A comes to rest, B retraces its path with the speed $V = 5\text{ms}^{-1}$.

What is the speed of C ?

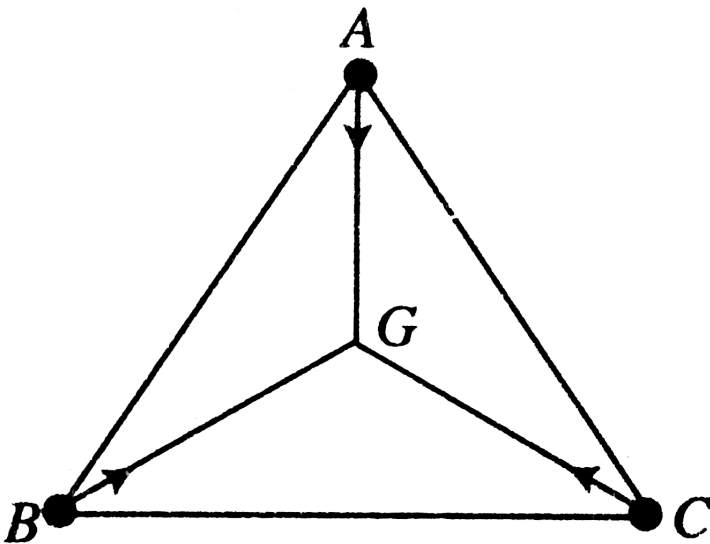



Watch Video Solution

11. N beads identical beads are resting on a smooth horizontal wire which is circular at the end with radius $r = 0.5m$ as shown in the figure. Find the minimum velocity which should be imparted to the first bead such that n th bead will fall in the tank after completing full circle in vertical plane as shown in the figure. Take all the collisions between the beads

elastic ($e = 1$).

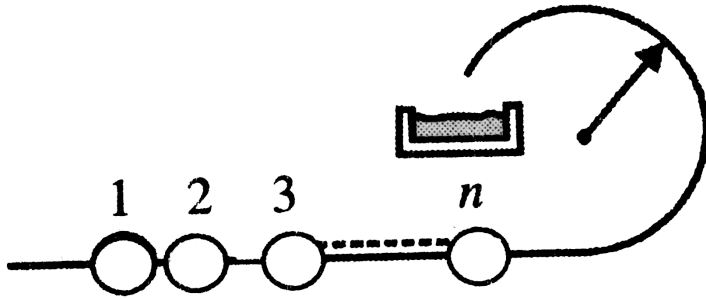

[Watch Video Solution](#)

12. An elevator platform is going up at a speed of $20m/s$ and during its upward motion a small ball of $50g$ mass, falling in downward direction, strikes the platform at speed $5m/s$. Find the speed with which the ball rebounds.



Watch Video Solution

13. Figure shows a wedge A of mass $6m$ smooth semicircular groove of radius $a = 8.4m$ placed on a smooth horizontal surface. A small block B of mass m is released from a position in groove where its radius is horizontal. Find the speed (in ms^{-1}) of bigger block when smaller block reaches its

bottommost position.

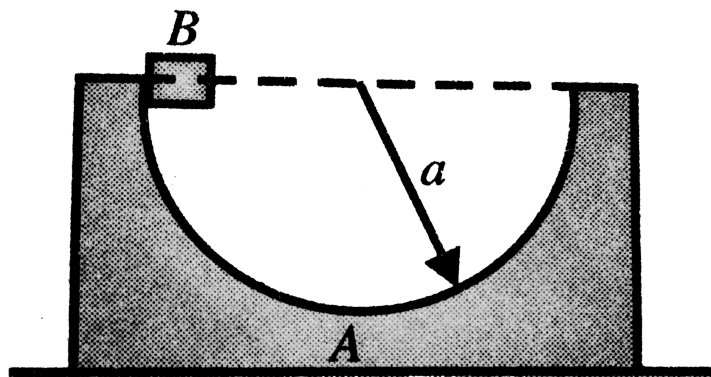

[Watch Video Solution](#)

14. A ball of mass m is allowed to roll down the wedge of mass $M = 2m$ as shown in the figure. What is the displacement of wedge (in m) when the ball reaches from A to B ? Take

$$\theta = 45^\circ, h = 1m, d = 4m$$

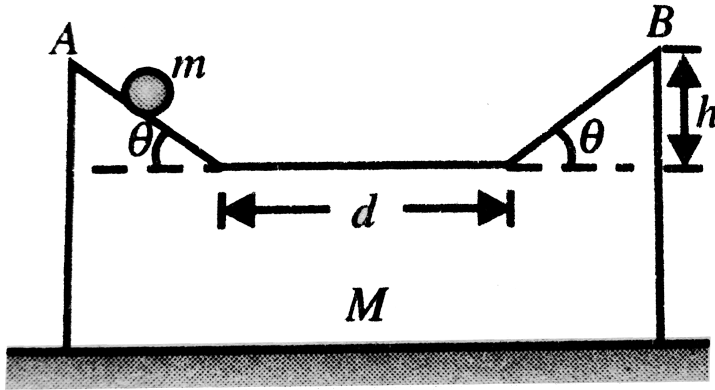

Watch Video Solution

15. A railway flat car, whose mass together with the artillery gun is $M = 2m$, moves at a speed V . The gun barrel makes an angle $\alpha = 60^\circ$ with the horizontal. A shell of mass m leaves

the barrel at a speed $v = 12\text{ms}^{-1}$, relative to the barrel. Find the speed of the flat car V (in ms^{-1}) in order that it may stop after the firing.



[Watch Video Solution](#)

16. Two particles of mass 1 kg and 3 kg move towards each other under their mutual force of attraction. No other force acts on them. When the relative velocity of approach of the two particles is 2m/s , their centre of mass has

a velocity of 0.5 m/s . When the relative velocity of approach becomes 3 m/s , the velocity of the centre of mass is 0.75 m/s .



[Watch Video Solution](#)

Fill In The Blanks

1. A body of mass $(4m)$ is lying in xy -plane at rest. It suddenly explodes into three pieces. Two pieces each of mass (m) move perpendicular to each other with equal speeds

(v). The total kinetic energy generated due to explosion is



[Watch Video Solution](#)

2. The magnitude of the force (in newtons) acting on a body varies with time t (in micro seconds) as shown in the fig AB, BC and CD are straight line segments. The magnitude of the total impulse of the force on the body from

$t = 4\mu\text{s}$ to $t = 16\mu\text{s}$ is ...Ns

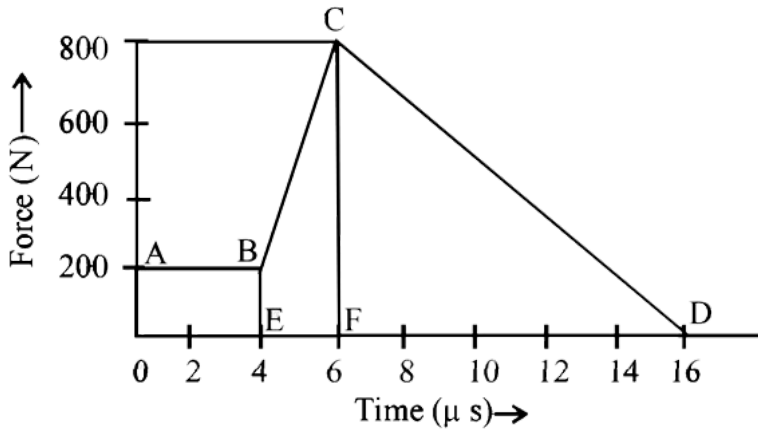

[Watch Video Solution](#)

SCQ_TYPE

1. Two particles A and B initially at rest, move towards each other under a mutual force of

attraction. AT the instant when the speed of A is v and the speed of B is $2v$, the speed of the centre of mass of the system is

A. 3

B. v

C. $1.5v$

D. zero

Answer: D



Watch Video Solution

2. A uniform chain of length L and mass M is lying on a smooth table and one third of its length is hanging vertically down over the edge of the table. If g is acceleration due to gravity, work required to pull the hanging part on to the table is

A. MgL

B. $MgL/3$

C. $MgL/9$

D. $MgL/18$

Answer: D



Watch Video Solution

3. A ball hits a floor and rebounds after an inelastic collision. In this case

A. the momentum of the ball just after collision is same as that just before the collision

B. the mechanical energy of the ball remains the same in collision

C. the total momentum of the ball and the earth is conserved

D. the total mechanical energy of the ball and the earth is conserved

Answer: C



Watch Video Solution

4. A shell is fired from a cannon with a velocity V at an angle θ with the horizontal direction. At the highest point in its path, it explodes into two pieces of equal masses. One of the pieces retraces its path to the cannon. The speed of the other piece immediately after the explosion is

A. $3v \cos \theta$

B. $2v \cos \theta$

C. $\frac{3}{2}v \cos \theta$

D. $\sqrt{\frac{3}{2}}v \cos \theta$

Answer: A



Watch Video Solution

5. An isolated particle of mass m is moving in horizontal plane xy along the x -axis, at a certain height above the ground. It suddenly explodes into two fragment of masses $m/4$ and $3m/4$. An instant later, the smaller fragment is at $y = +15$ cm. The larger fragment at this instant is at

A. $y = -5\text{cm}$

B. $y = +20\text{cm}$

C. $y = +5\text{cm}$

D. $y = -20\text{cm}$

Answer: A



Watch Video Solution

6. Two particles of masses m_1 and m_2 in projectile motion have velocities \vec{v}_1 and \vec{v}_2 , respectively, at time $t = 0$. They collide at

time t_0 . Their velocities become \vec{v}'_1 and \vec{v}'_2 at time $2t_0$ while still moving in air. The value of

$$\left| \left(m_1 \vec{v}'_1 + m_2 \vec{v}'_2 \right) - \left(m_1 \vec{v}_1 + m_2 \vec{v}_2 \right) \right|$$

A. zero

B. $(m_1 + m_2)t_0$

C. $\frac{1}{2}(m_1 + m_2)t_0$

D. $2(m_1 + m_2)t_0$

Answer: D



Watch Video Solution

7. Two blocks of masses 10 kg and 4 kg are connected by a spring of negligible mass and placed on a frictionless horizontal surface. An impulse gives a velocity of 14m/s to the heavier block in the direction of the lighter block. The velocity of the centre of mass is

A. 30m/s

B. 20m/s

C. 10m/s

D. 5m/s

Answer: C



Watch Video Solution

8. A particle moves in the xy plane under the influence of a force such that its linear momentum is

$$\vec{P}(t) = A \left[\hat{i} \cos(kt) - \hat{j} \sin(kt) \right], \text{ where } A$$

and k are constants. The angle between the force and momentum is

A. 0°

B. 30°

C. 45°

D. 90°

Answer: D



Watch Video Solution

9. Look at the drawing given in the figure which has been drawn with ink of uniform line-thickness. The mass of ink used to draw each of the two inner circles, and each of the two

line segments is m . The mass of the ink used to draw the outer circle is $6m$.

The coordinates of the centres of the different parts are: outer circle $(0, 0)$, left inner circle $(-a, a)$, right inner circle (a, a) , vertical line $(0, 0)$ and horizontal line $(0, -a)$. The y -coordinate of the centre of mass of the ink in

this drawing is

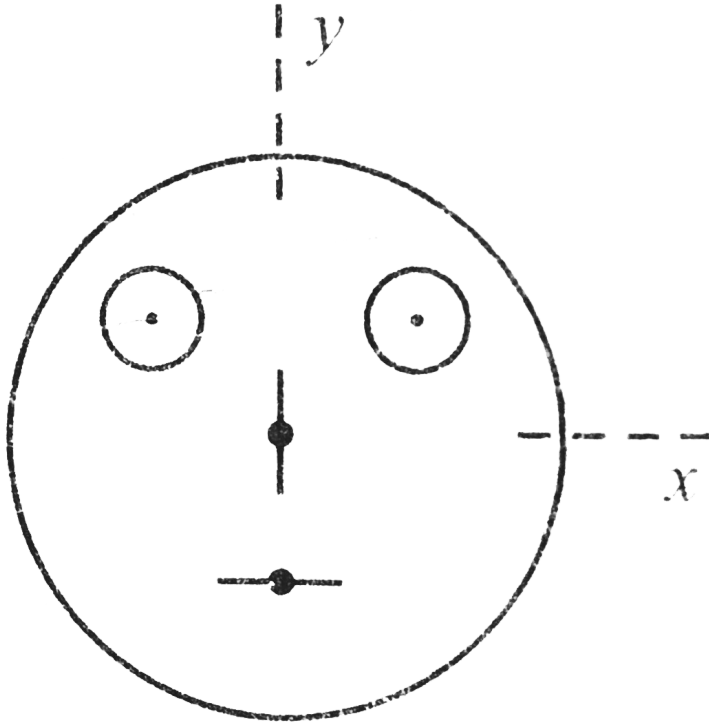

A. $\frac{a}{10}$

B. $\frac{a}{8}$

C. $\frac{a}{12}$

D. $\frac{a}{3}$

Answer: A



Watch Video Solution

10. Two small particles of equal masses start moving in opposite direction from a point A in a horizontal circular orbit. Their tangential velocities are V and $2V$, respectively as shown in the figure. Between collisions, the particles move with constant speed. After making how

many elastic collision , other the then that at A these two partical will again reach the point A ?

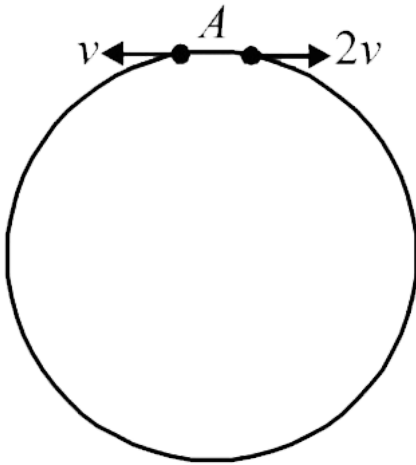

A. 4

B. 3

C. 2

D. 1

Answer: C



Watch Video Solution

11. A block of mass 2kg is free to move along the x-axis. It is at rest and from $t = 0$ onwards, it is subjected to a time-dependent force $F(t)$ in the x-direction. The force $F(t)$ varies with t as shown in figure. The kinetic energy of the

block after 4.5s is

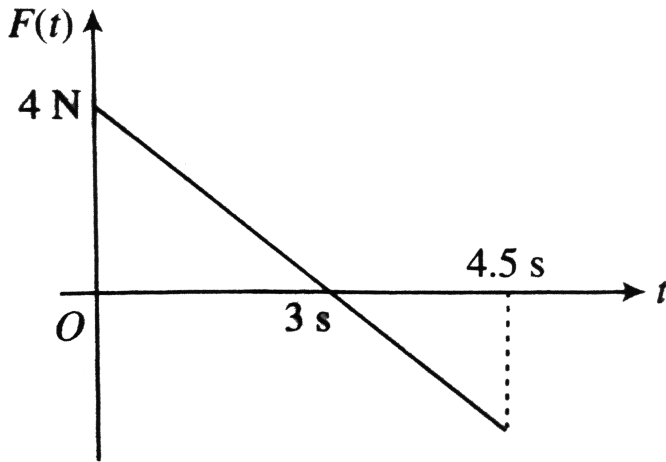

A. 4.50 J

B. 750 J

C. 5.06 J

D. 14.06 J

Answer: C



Watch Video Solution

12. A ball of mass 0.2 kg rests on a vertical post of height 5 m. A bullet of mass 0.01 kg, travelling with a velocity $V \text{ m/s}$ in a horizontal direction, hits the centre of the ball. After the collision, the ball and bullet travel independently. The ball hits the ground at a distance of 20 m and the bullet at a distance of 100 m from the foot of the post. The velocity

V of the bullet is

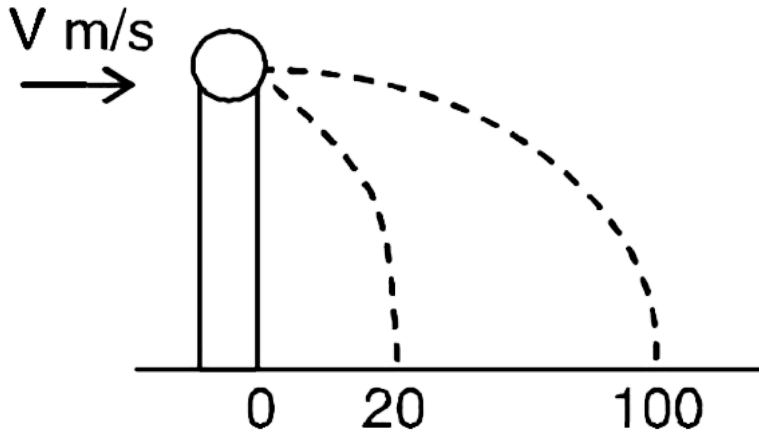

A. $250m / s$

B. $250\sqrt{2}m / s$

C. $400m / s$

D. $500m / s$

Answer: D



Watch Video Solution

MCQ_TYPE

1. A uniform rod of length $6a$ and mass $8m$ lies on a smooth horizontal table. Two particles of masses m and $2m$, moving in the same horizontal plane but in opposite directions with speeds $2v$ and v respectively strike and stick to the rod normally as shown in figure and stick to the rod. Denoting angular velocity (ω about the centre of mass), total energy and translational

velocity of centre of mass by ω , E and v_c respectively after the collision.

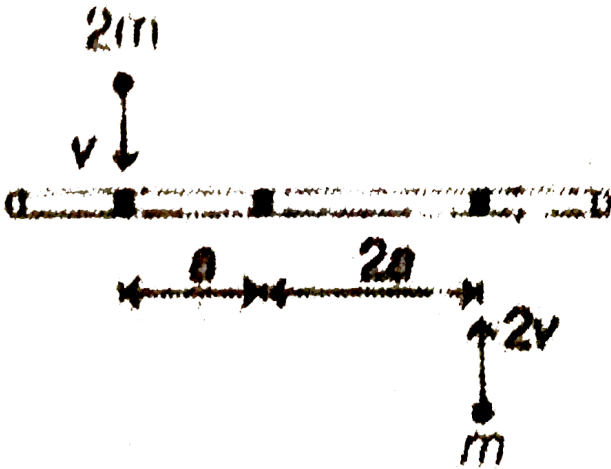

A. $V_c = 0$

B. $\omega = \frac{3v}{5a}$

C. $\omega = \frac{v}{5a}$

D. $E = \frac{3mv^2}{5}$

Answer: A::C::D



Watch Video Solution

2. Two blocks A and B , each of mass m , are connected by a massless spring of natural length l and spring constant K . The blocks are initially resting in a smooth horizontal floor with the spring at its natural length, as shown in Fig. A third identical block C , also of mass m , moves on the floor with a speed v along the line joining A and B , and collides

elastically with A . Then

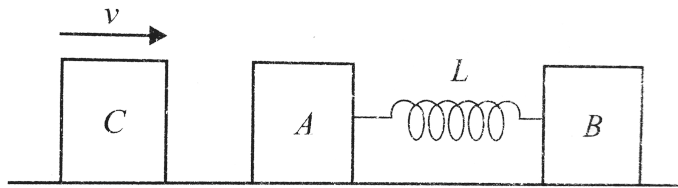

A. the kinetic energy of the $A - B$ system,
at maximum compression of the spring,
is zero.

B. the kinetic energy of the $A - B$ system,
at maximum compression of the spring,
is

C. the maximum compression of the spring

$$\text{is } \sqrt{\left(\frac{m}{K}\right)}$$

D. the maximum compression of the spring

$$\text{is } v \sqrt{\left(\frac{m}{2K}\right)}$$

Answer: B::D



Watch Video Solution

3. Two balls having linear momenta $\vec{p}_1 = p\hat{i}$ and $\vec{p}_2 = -p\hat{i}$, undergo a collision in free space. There is no external force acting on the

ball. Let \vec{p}'_1 and \vec{p}'_2 be their final momenta.

Which of the following option(s) is (are) NOT ALLOWED for an non zero value of p , a_1 , a_2 , b_1 , b_2 , c_1 and c_2 .

A.

$$\vec{p}'_1 = a_1 \hat{i} + b_1 \hat{j} + c_1 \hat{k}, \vec{p}'_2 = a_2 \hat{i} + b_2 \hat{j}$$

B. $\vec{p}'_1 = c_1 \hat{k}, \vec{p}'_2 = c_2 \hat{k}$

C.

$$\vec{p}'_1 = a_1 \hat{i} + b_1 \hat{j} + c_1 \hat{k}, \vec{p}'_2 = a_2 \hat{i} b_2 \hat{j} - c_2 \hat{k}$$

D. $\vec{p}'_1 = a_1 \hat{i} + b_1 \hat{j}, \vec{p}'_2 = a_2 \hat{i} + b_1 \hat{j}$

Answer: A::D



Watch Video Solution

4. A point mass of 1kg collides elastically with a stationary point mass of 5 kg. After their collision, the 1kg mass reverses its direction and moves with a speed of $2ms^{-1}$. Which of the following statements (s) is (are) correct for the system of these two masses?

A. Total momentum of the system is

$$3\text{kgms}^{-1}$$

B. Momentum of 5kg mass after collision is

$$4\text{kgms}^{-1}$$

C. Kinetic energy of the centre of mass is

$$0.75\text{J}$$

D. Total kinetic energy of the system is 4J

Answer: A:C



Watch Video Solution

1. Statement I: In an elastic collision between two bodies, the relative speed of the bodies after collision is equal to the relative speed before the collision.

Statement II: In an elastic collision, the linear momentum of the system is conserved.

A. Both Statement I and Statement II are true and Statement II is the correct explanation of Statement I

B. Both Statement I and Statement II are true but Statement II is not the correct explanation of Statement I.

C. Statement I is true and Statement II is false.

D. Statement I is false and Statement II is true.

Answer: D



Watch Video Solution

1. A small block of mass M moves on a frictionless surface of an inclined plane as shown in the figure. The angle of the incline suddenly changes from 60° to 30° at point B. The block is initially at rest at A. Assume that collisions between the block and the incline are totally inelastic. The speed of the block at point B immediately after it strikes the second

incline is

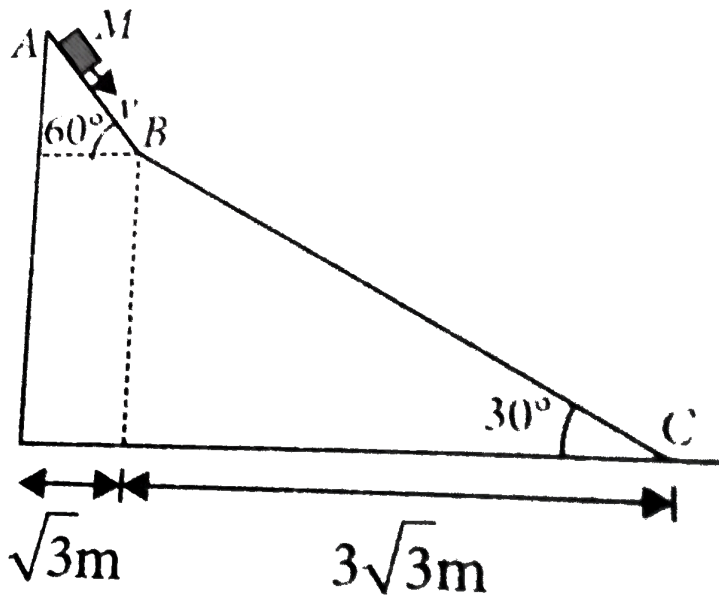

A. $\sqrt{60}m / s$

B. $\sqrt{45}m / s$

C. $\sqrt{30}m / s$

D. $\sqrt{15}m / s$

Answer: B



Watch Video Solution

2. A small block of mass M moves on a frictionless surface of an inclined plane as shown in the figure. The angle of the incline suddenly changes from 60° to 30° at point B. The block is initially at rest at A. Assume that collisions between the block and the incline are totally inelastic. The speed of the block at point B immediately after it strikes the second

incline is

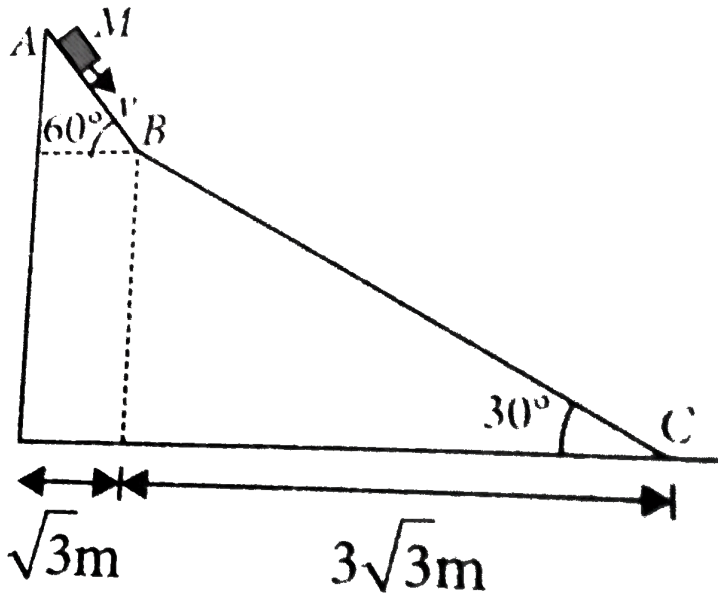

A. $\sqrt{120}m / s$

B. $\sqrt{105}m / s$

C. $\sqrt{90}m / s$

D. $\sqrt{75}m / s$

Answer: D



Watch Video Solution

3. A small block of mass M moves on a frictionless surface of an inclined plane, as shown in the figure. The angle of the incline suddenly changes from 60° to 30° at point B . The block is initially at rest at A .

If collision between the block and the incline is completely elastic, then the vertical (upward) component of the velocity of the blocks at

point B , immediately after it strikes the second incline is

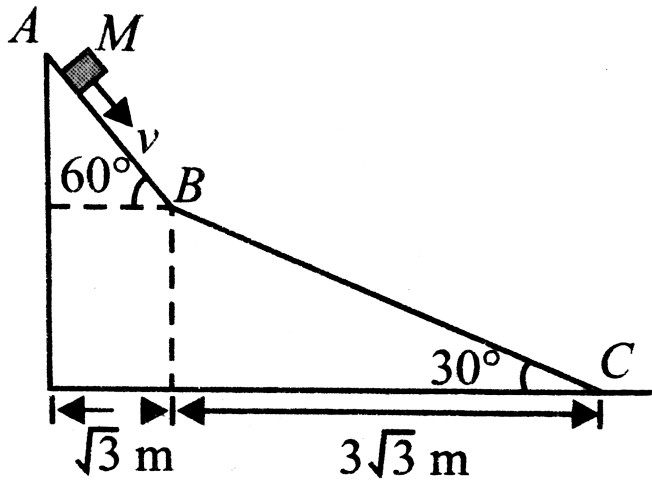

- A. $\sqrt{30} \text{ m} / \text{s}$
- B. $\sqrt{15} \text{ m} / \text{s}$
- C. 0
- D. $-\sqrt{15} \text{ m} / \text{s}$

Answer: C



Watch Video Solution

INTEGER_TYPE

1. Three objects A , B and C are kept in a straight line on a smooth horizontal surface. These have masses m , $2m$ and $3m$, respectively. The head-on elastic collision takes place between A and B and then B makes completely inelastic collision with C . All

motions occur on the same straight line. The

final speed of C will be

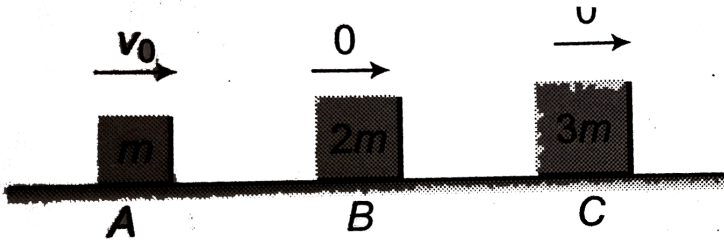

[Watch Video Solution](#)