



PHYSICS

BOOKS - CENGAGE PHYSICS (ENGLISH)

NEWTON'S LAWS OF MOTION 2

Illustration

1. A block of weight $100N$ lying on a horizontal surface just begins to move when a horizontal force of $25N$ acts on it. Determine the coefficient of static friction.



Watch Video Solution

2. In Fig force F is gradually increased from zero Draw the graph between applied force F and tension T in the string . The coefficient of static friction between the block and the ground is μ_s

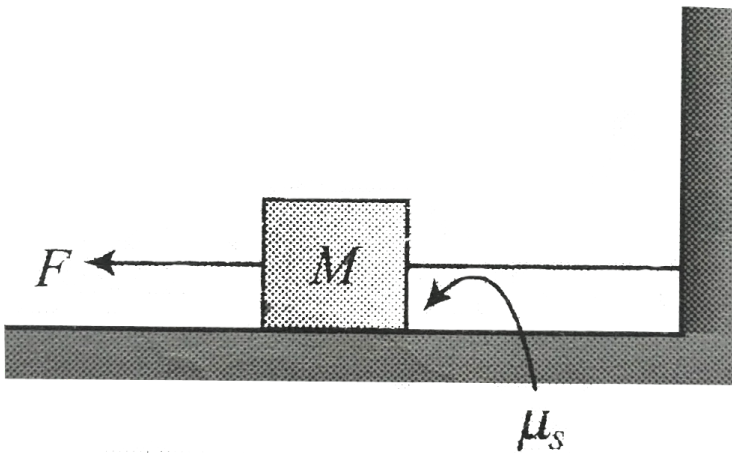

Watch Video Solution

3. Find the least pulling force which acting at an angle of 45° with the horizontal will slide a body weighing $5kg$ along a rough horizontal surface . The coefficient of friction $\mu_s = \mu_k = 1/3$ If a force of double this is applied along the same direction , find the resulting acceleration of the block

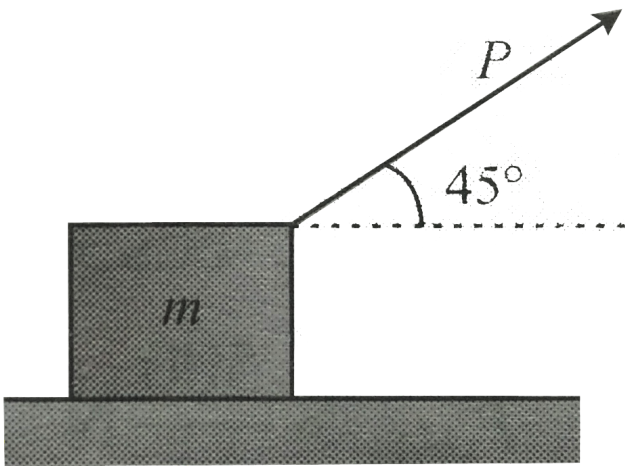

[Watch Video Solution](#)

4. Force F is gradually increased from zero .Determine whether the block will first slide or lift up?

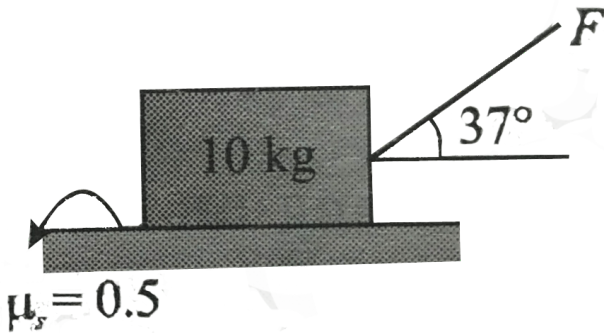

[▶ Watch Video Solution](#)

5. In Figure an object of mass $M = 10\text{kg}$ is kept on a rough table as seen from above forces are applying on it as shown . Find the direction of static friction if the

object does not move (Take $\mu = 0.4$)

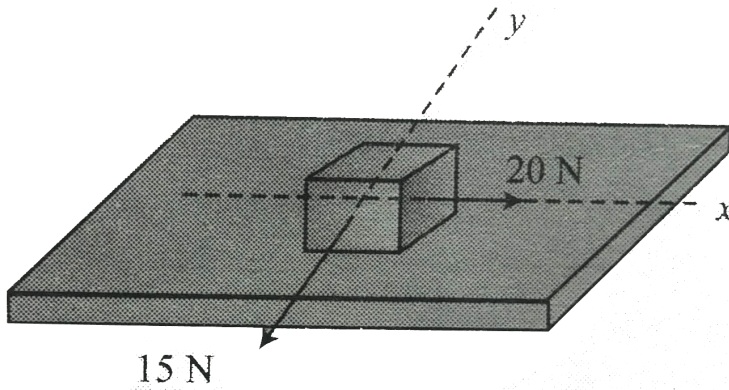

[Watch Video Solution](#)

6. A block of mass 2 kg is pushed against a rough vertical wall with a force of 40N. Coefficient of static friction being 0.5. Another horizontal force of 15 N, is applied on the block in a direction parallel to the wall. Will the block move? If yes in which direction? If no, find the frictional force exerted by the wall on the block.

7. Determine the magnitude of frictional force and acceleration of the block in each of the following cases :

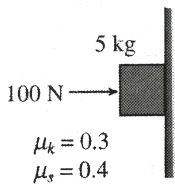

Case I

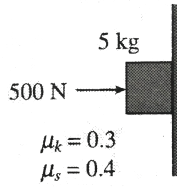

Case II

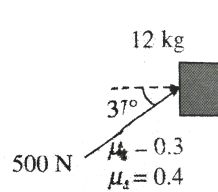

Case III

8. A block of mass m is supported on a rough wall by applying a force in figure Coefficient of static friction between block and wall is μ

For what range of value of p , the block remain in static

equilibrium ?

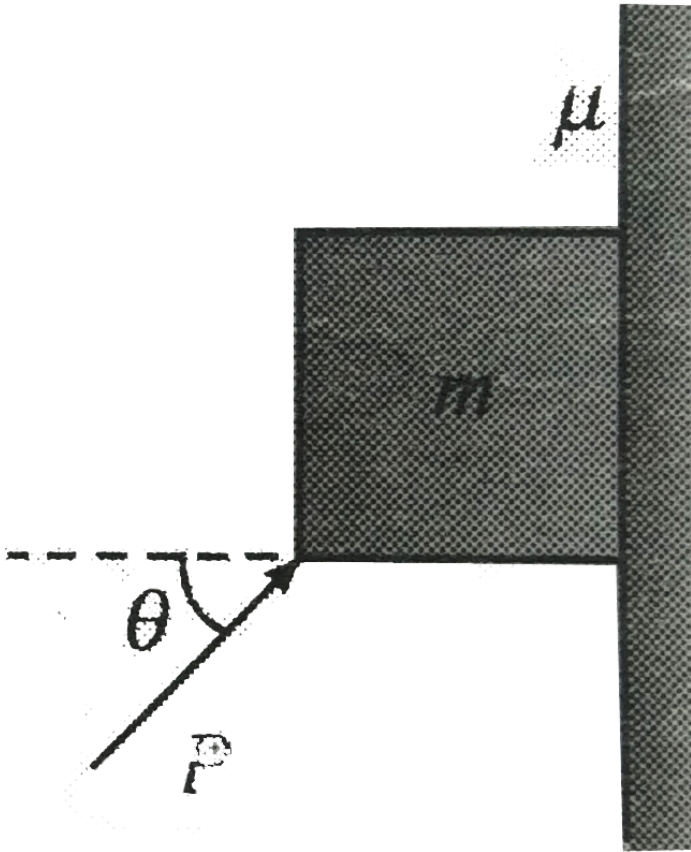

Watch Video Solution

9. A block A slides over another block B which is placed over a smooth inclined plane as shown in figure . The coefficient of friction between the two blocks A and B is μ . Mass of block B is two times the mass of block A . The acceleration of the centre of mass of two blocks is

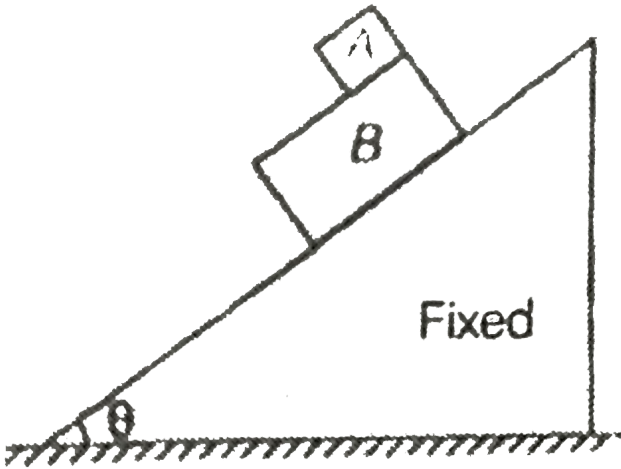

[Watch Video Solution](#)

10. Block A weight $4N$ and block B weight $8N$ The coefficient of kinetic friction is 0.25 for all surface. Find F to slide B at constant speed when

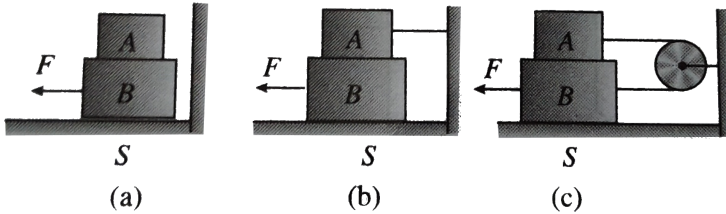

A is held at rest

[Watch Video Solution](#)

11. The friction coefficient between the board and the floor shown in figure is μ Find the maximum force that the man can exert on the rope so that the board does

not slip on the floor

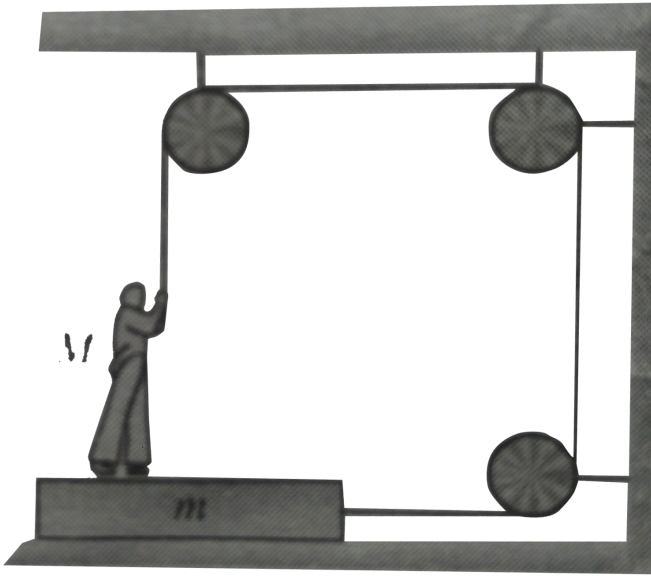

[Watch Video Solution](#)

12. A block of mass m lying on a horizontal surface (coefficient of static friction $= \mu_s$) is to be brought into motion by a pulling force F . At what angle θ with the horizontal should the force F be applied so that its

magnitude is minimum ? Also find the minimum magnitude

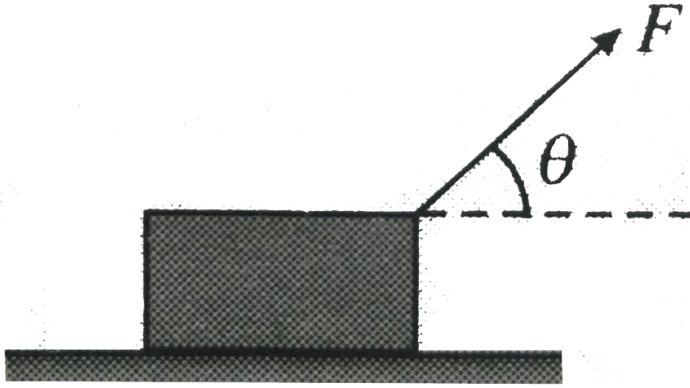

[Watch Video Solution](#)

13. A block of mass M is kept on a rough horizontal surface. The coefficient of static friction between the block and the surface is μ . The block is to be pulled by applying a force to it. What minimum force is needed to

slide the block? In which direction should this force act?



[Watch Video Solution](#)

14. A block lying on an inclined plane has a weight of $50N$. It just begins to slide down when inclination of plane with the horizontal is 30° . Find the coefficient of static plane friction.



[Watch Video Solution](#)

15. A block of mass $1kg$ is placed on a rough inclined plane at angle $\theta = 45^\circ$ with the horizontal. The block is

connected with a straight as straight as shown in figure

if $\mu = 3/4$ find the tension in string

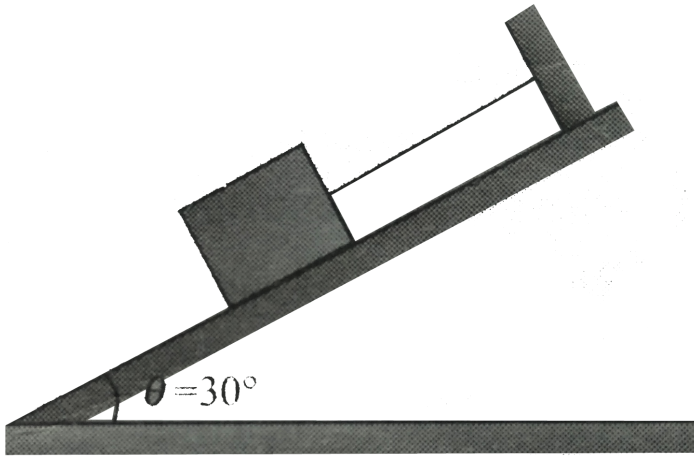

[Watch Video Solution](#)

16. An object of mass 10kg is to be kept at rest on an inclined plane making an angle of 37° to the horizontal by applying a force F along the plane upwards as shown in figure . The coefficient of static friction

between the object and the plane is 0.2 Find the magnitude of force F

[Take $g = 10\text{ m/s}^{-2}$]

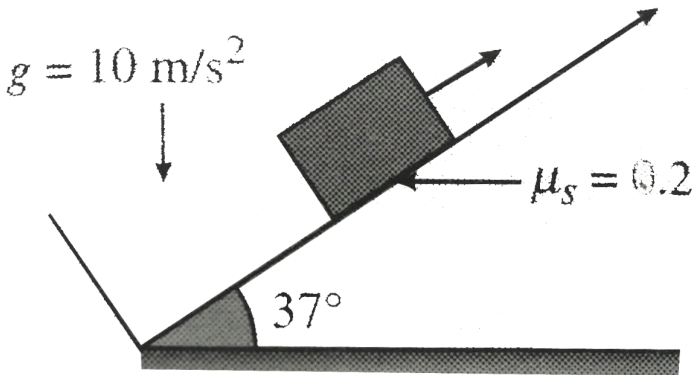

$$\sin 37^\circ = 0.6$$

$$\cos 37^\circ = 0.8$$

[Watch Video Solution](#)

17. A 5 kg block slides down a plane inclined at 30° to the horizontal. Find

(a) The acceleration of the block if the plane is

frictionless

b. The acceleration if the coefficient of kinetic friction is

$$1/2\sqrt{3}$$



Watch Video Solution

18. A $5kg$ block is projected upwards with an initial speed of $10ms^{-1}$ from the bottom of a plane inclined at 30° with horizontal . The coefficient of kinetic friction between the block and the plane is 0.2

a. How far does the block move up the plane ?

b. How long does it move up the plate ?

c. After time from its projection does the block again come to the bottom ? What speed does it arrive?



Watch Video Solution

19. A block of mass $M = 10\text{kg}$ is placed on an inclined plane, inclined at an angle $\theta = 37^\circ$ with the horizontal. The coefficient of friction between the block and the inclined plane is $\mu = 0.5$.

a. Calculate the acceleration of the block when it is released.

b. Now a force $F = 75\text{N}$ is applied on the block as shown. Find out the acceleration of the block if the block is initially at rest.

c. In case (b), how much force should be added to the 75N force so that the block starts to move up the incline.

d. In case (b), what is the minimum force by which the 75N force should be replaced so that the block does

not move?

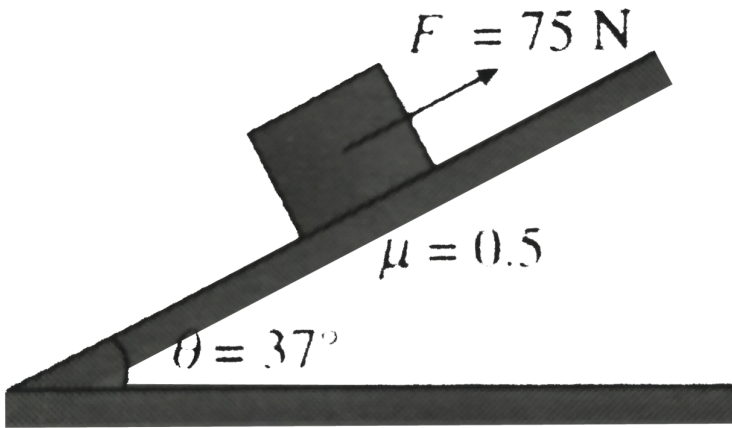
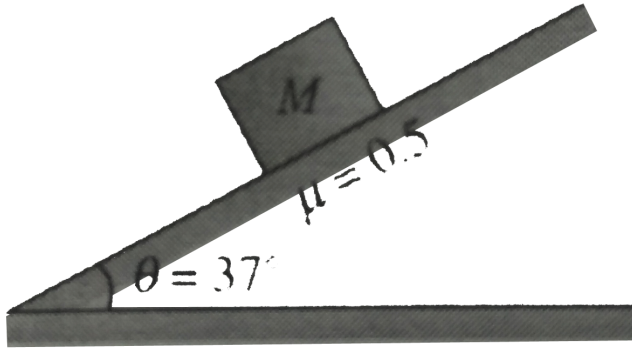

Watch Video Solution

20. Two block M and and m are arranged as shows in figure . If $M = 50kg$ then determine the minimum and maximum value of mass of block the heavy block M stationary

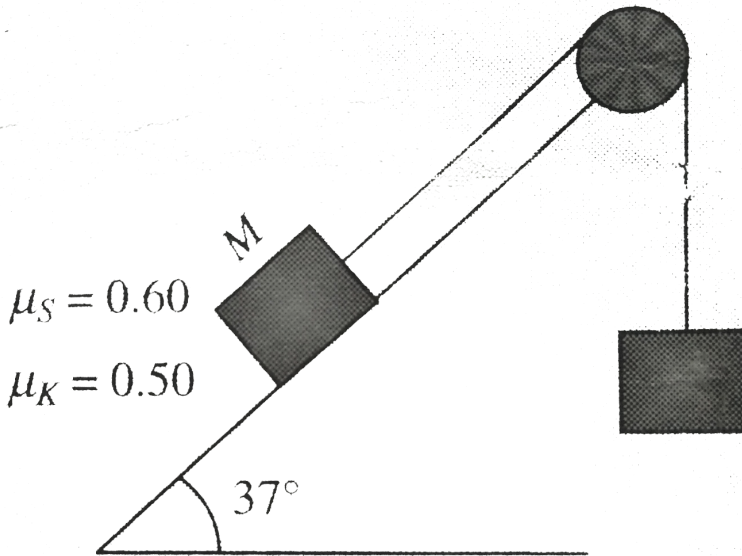

Watch Video Solution

21. Two block A and B of mass $m_A = 10kg$ and $m_B = 20kg$ are place on rough horizontal surface . The blocks are connected with a string. If the coefficient of friction between block A and ground is $\mu_A = 0.9$ and between block B and ground is $\mu_B = 0.3$ and the tension in the string in situation as shown in fig force $120N$ and $100N$ start acting when the system is at rest?

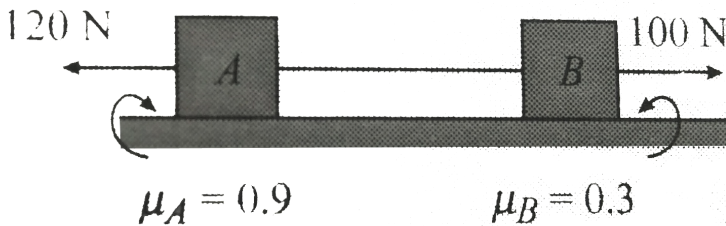

[Watch Video Solution](#)

22. Block A of mass m and block B of mass $2m$ are placed on a fixed triangular wedge by means of a light and inextensible string and a frictionless pulley as shown in fig . The wedge is inclined at 45° to the horizontal on both sides . The coefficient of friction between the block A and the wedge is $2/3$ and that between the block B and the wedge is $1/3$.If the system of A and B is released from rest then find .

a. the acceleration of A

b. tension in the string

c.the magnitude and direction of the frictional force

acting on A

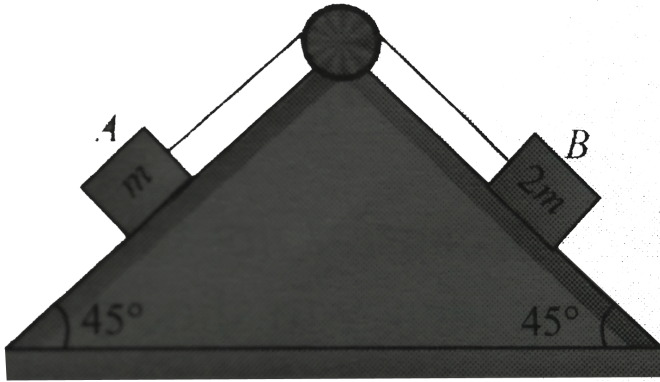

Watch Video Solution

23. Figure shown two blocks in contact sliding down an inclined surface of inclination 30° . The friction coefficient between block of mass $2kg$ and the incline is $\mu_1 = 0.20$ and that between the block of mass $4kg$ and the incline is $\mu_2 = 0.30$. Find the acceleration of $2.0kg$

$$\text{block } g = 10\text{ms}^{-2}$$

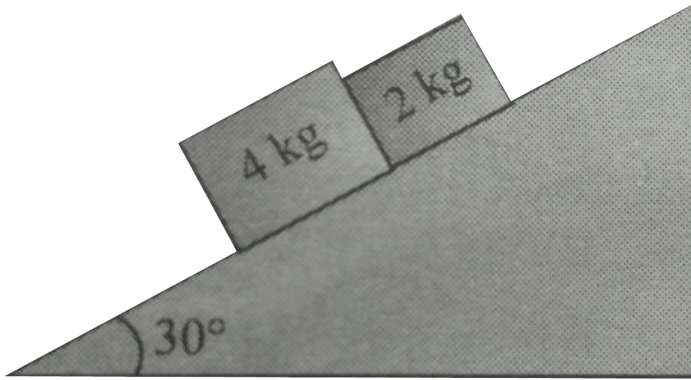

[▶ Watch Video Solution](#)

24. Two blocks m_1 and m_2 are acted upon by the forces F_1 and F_2 as shown in figure . If no relative sliding between is smooth , find the static friction between the blocks. Make necessary assumptions and discuss

different cases.

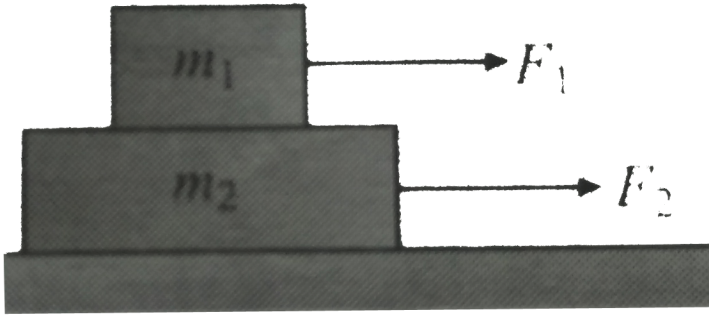

[Watch Video Solution](#)

25. In fig Block m_2 is loaded on block m_1 . If there is no relative sliding between the block and the inclined plane is smooth , find the friction force between the

block

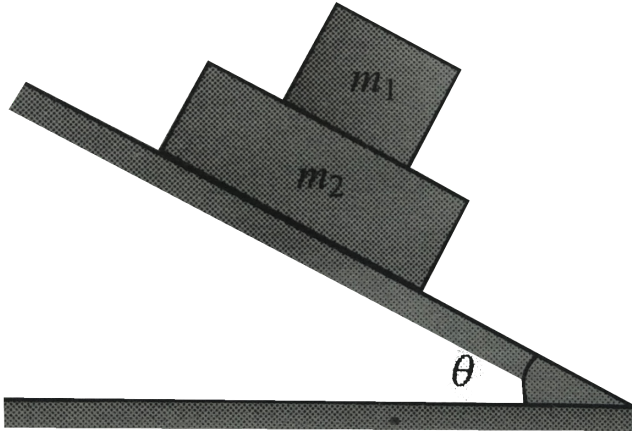

Watch Video Solution

26. There are two block as shown in the figure of masses $1kg$ and $4kg$. Friction coefficient between any two surfaces are 0.2 then find maximum value of

horizontal force F so that both blocks moves together.

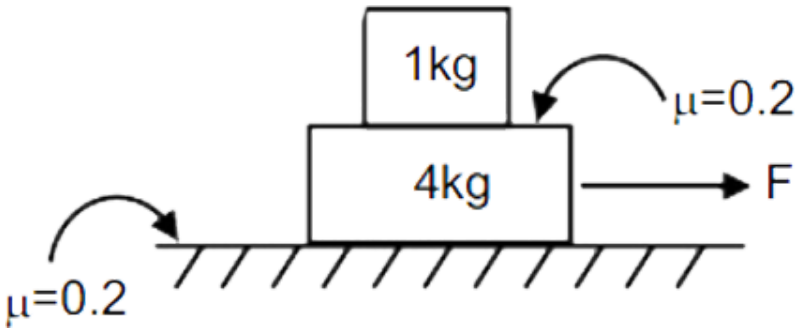

[Watch Video Solution](#)

27. Let us consider the next case in the previous illustration when there is no friction between ground and M . The coefficient of static and kinetic friction are μ_2 and μ_1 , respectively, and force F acts upper block as shown in figure

a. What is the maximum possible value of F so that the system moves together ?

b . If there is relative sliding between M and m then calculate acceleration of M and m

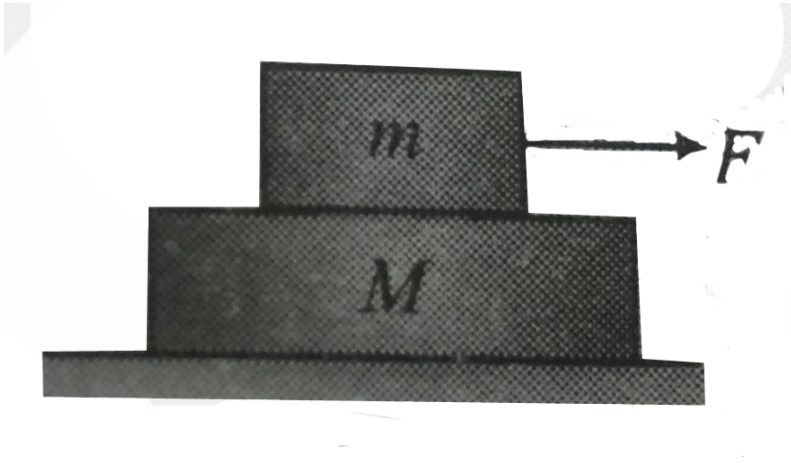

[Watch Video Solution](#)

28. Two blocks A and B of mass $10kg$ and $20kg$ respectively, are arranged as shown in figure In the figure given a constant force $F_0 = 120N$ act on block A and a force F applied horizontally on block B is gradually increased from zero. Discuss the direction

and nature of friction force and the accelerations of the block for different value of F

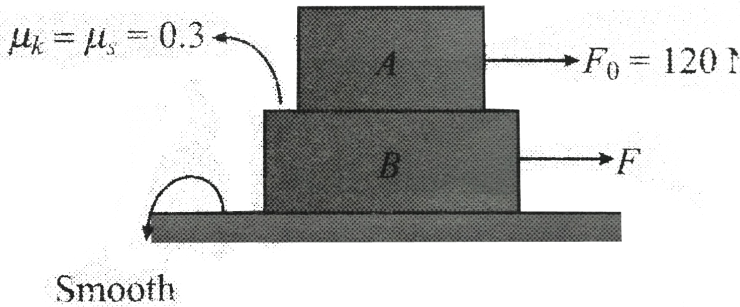

[Watch Video Solution](#)

29. In the Fig force $F = \alpha t$ is applied on the block of mass m_2 . Here α is a constant and t is the time. Find the acceleration of the block. Also draw the acceleration

time graph of both the block

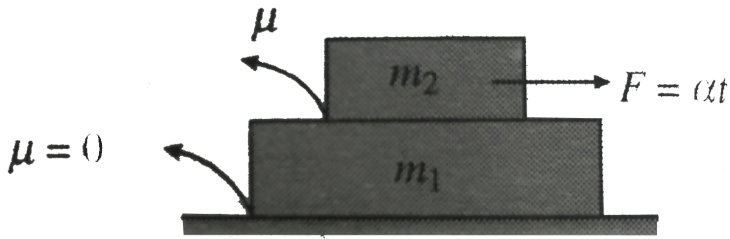

Watch Video Solution

30. The masses of the blocks A , B and C shown in fig

(a) are 4kg , 2kg and 2kg respectively Block A moves

with an acceleration of 2.5ms^{-2}

a. Block C is removed from its in position and placed on

block A fig (b). What is now the acceleration of block C

?

b. The position of the block A and B subsequently

interchanged find the new acceleration of C .

The coefficient of friction is the same for all the contact surface.



Watch Video Solution

31. Consider the two blocks as shown in Fig A force is applied on the lower blocks.

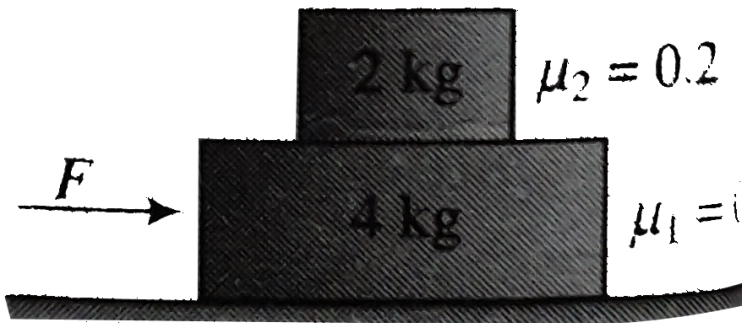

a. Where does the sliding begins first ?

b. What is the minimum force at which any part of system start sliding ?

c. At what value of force F will the sliding start at the other surface ?

d. For the following values of F , find the acceleration of the sliding two blocks , nature and value of friction at both rough surface?

i. $3N$ ii. $12N$ iii. $24N$



[Watch Video Solution](#)

32. (a) Find the acceleration of the two block shown in figuer (b) Find the friction force between all contact

surface

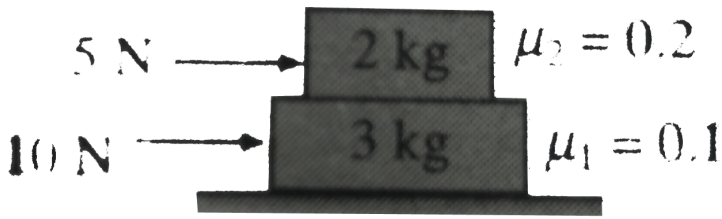

[Watch Video Solution](#)

33. The coefficient of friction between the block A of mass m and the triangular wedge B of mass M is μ . There is no friction between the wedge and the plane if the system (block A + wedge B) is released so that there is no sliding between A and B find the

inclination θ

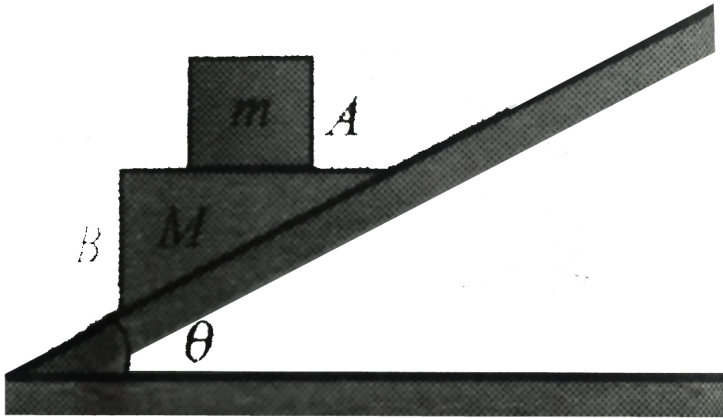

Watch Video Solution

34. A block A of mass m which is placed on the rough inclined face of a wedge of same mass being pulled through a light string and with force F as shown in figure. The coefficient of friction between the inclined face and block A is μ while there is no friction between the

ground and wedge it the whole system moves with same acceleration then find the value of F

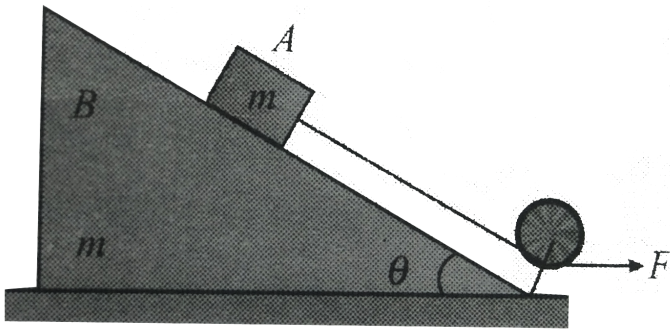

Watch Video Solution

35. Given the setup shown in Fig Block A , B and C have masses $m_A = M$ and $m_B = m_C = m$. The strings are assumed massless and unstretchable, and the pulleys frictionless. There is no friction between block B and the support table, but there is friction between blocks

B and C , denoted by a given coefficient μ

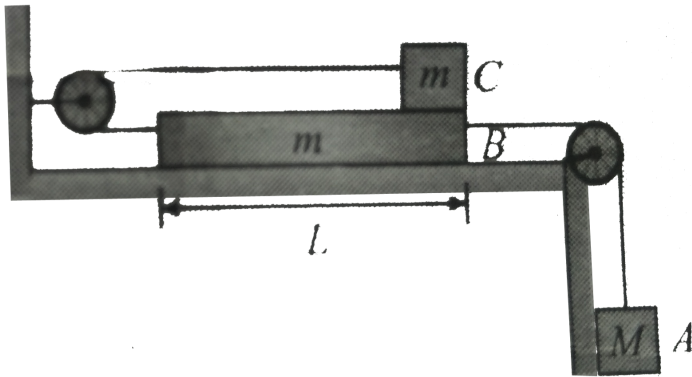

a. In terms of the given find (i) the acceleration of block A and B

b. Suppose the system is released from rest with block C near the right end of block B as shown in the above figure. If the length L of block B is given, what is the speed of block C as it reaches the left end of block B ? Treat the size of C as small

c. If the mass of block A is less than some critical value, the blocks will not accelerate when released from rest.

Write down an expression for that critical mass.



Watch Video Solution

36. The pulley of the system shown in Fig is massless and frictionless and thread and thread is inextensible
Then horizontal surface over which block C is smooth
while for all the remaining surface is μ

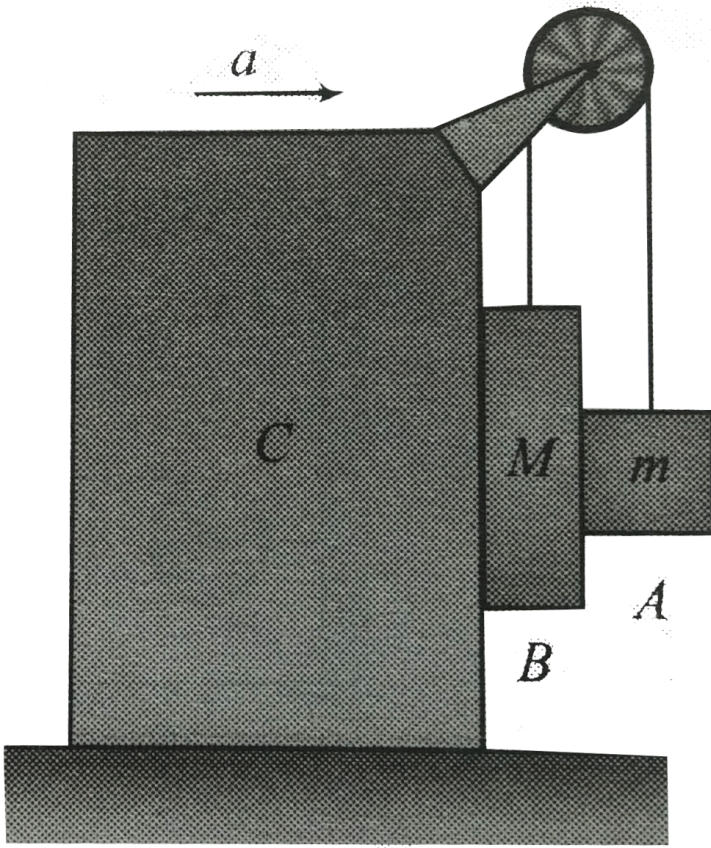

Calculate minimum acceleration a with which the system should be moved to the right so that suspended block A (mass m) and B (mass M and $M > m$) can remain stationary relative to C



Watch Video Solution

37. In Fig the coefficient of friction between the walls of block of mass m and the plank of mass M is μ . The same coefficient of friction is there between the plank and the horizontal floor. The force F is of 100N and the masses m and M are of 1kg and 3kg respectively. Find the value of μ . If the block does not slip along the wall of the plank.

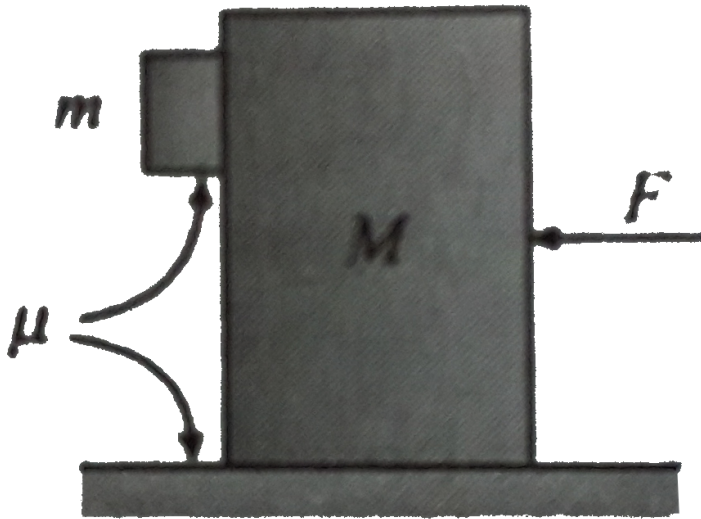

Watch Video Solution

38. The block of mass M and are arranged as the situation in fig is shown. The coefficient of friction between two block is μ and that between the bigger block and the ground is μ find the acceleration of the block.

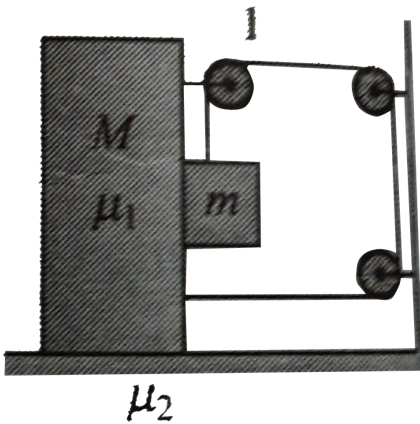

Watch Video Solution

39. A bar of mass m is placed on a triangular block of mass M as shown in figure. The friction coefficient between the two surfaces is μ and ground is smooth. Find the minimum and maximum horizontal force F required to be applied on block so that the bar will not slip on the inclined surface of block.

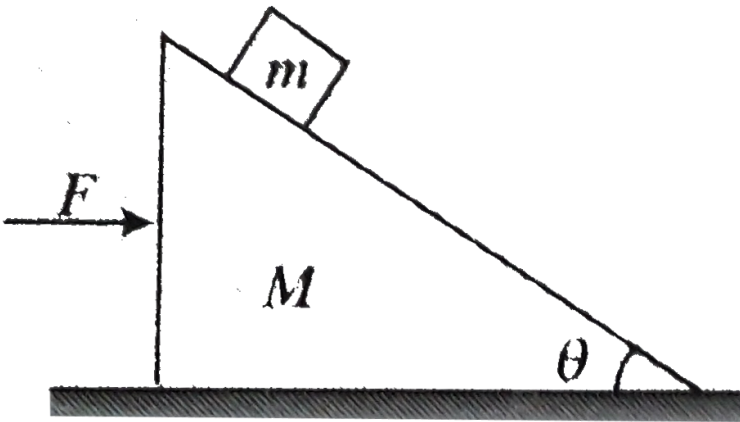

[Watch Video Solution](#)

40. A block of mass 1 kg is tied to a string of length 1 m, the other end of which is fixed. The block is moved on a smooth horizontal table with constant speed 10ms^{-1} . Find the tension in the string.



[Watch Video Solution](#)

41. The ball of mass m moves with speed v against a smooth, fixed vertical circular groove of radius R kept on smooth horizontal surface find the

- normal reaction of the floor on the ball.
- normal reaction of the vertical wall on the ball.



[Watch Video Solution](#)

42. A block of mass m is kept on the edge of a horizontal turn table of radius R which is rotating with constant angular velocity ω (along with the block) about its axis . If coefficient of friction is μ , find the friction force between block and table.

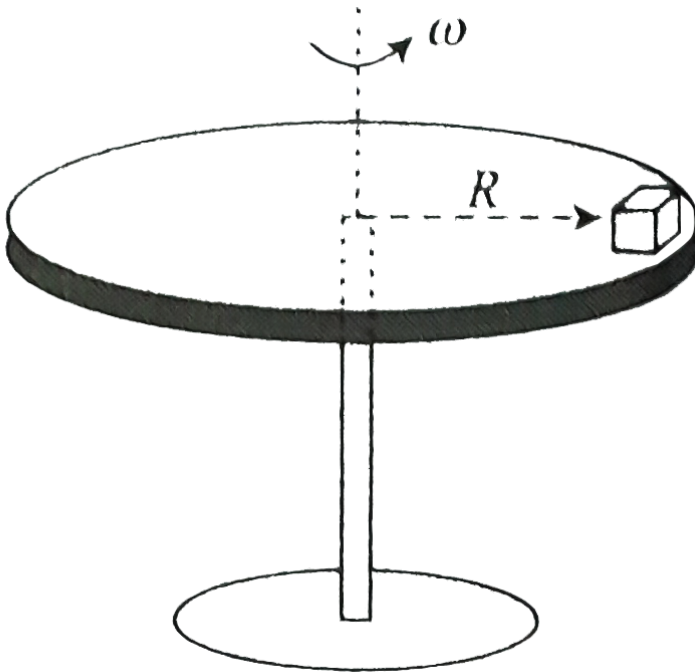

 [Watch Video Solution](#)

43. A car of mass m moving over a convex bridge of radius r . Find the normal reaction acting on car when it is at highest point the bridge.



Watch Video Solution

44. A car of mass m moving over a concave bridge of radius r . Find the normal reaction acting on car when it is at lowest point the bridge



Watch Video Solution

45. A small block is connected to one of two identical massless strings of length $16\frac{2}{3}cm$ each with their ends fixed to a verticle rod If the ratio of tensions T_1/T_2 is 4 : 1 ,then what will be the angular velocity of the block ? Take $g = 9.8ms^{-2}$

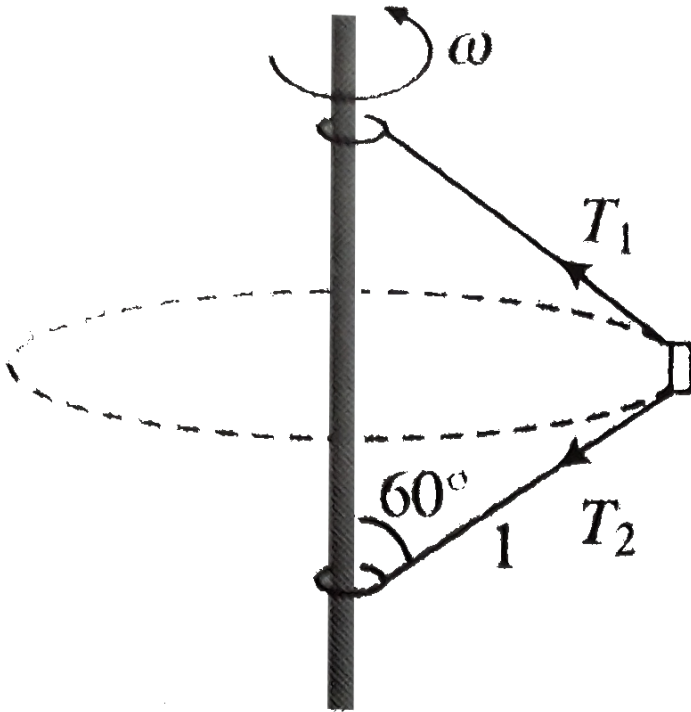

[Watch Video Solution](#)

46. Two wires AC and BC are tied at C of small sphere of mass 5kg which revolves at a constant speed v in the horizontal circle of radius 1.6m . Find the maximum value of v .

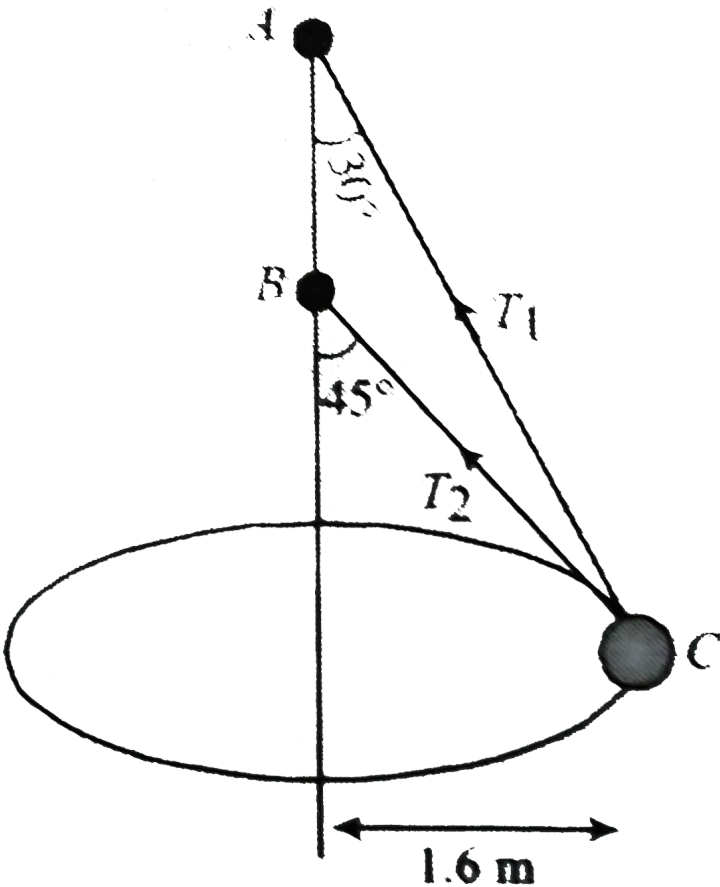



[Watch Video Solution](#)

47. A turn has a radius of $10m$ if a vehicle goes round it at an average speed of $18km/h$, what should be the proper angle of banking?



[Watch Video Solution](#)

48. A turn of radius $20 m$ is banked for the vehicles going at a speed of $36km/h$. If the coefficient of static friction between the road and the tyre is 0.4 , what are the possible speeds of a vehicle so that it neither slips down nor skids up?



49. A coin is pushed down tangentially from an angular position θ on a cylindrical surface, with a velocity v as shown in figure. If the coefficient of friction between the coin and surface is μ , find the tangential acceleration of the coin.

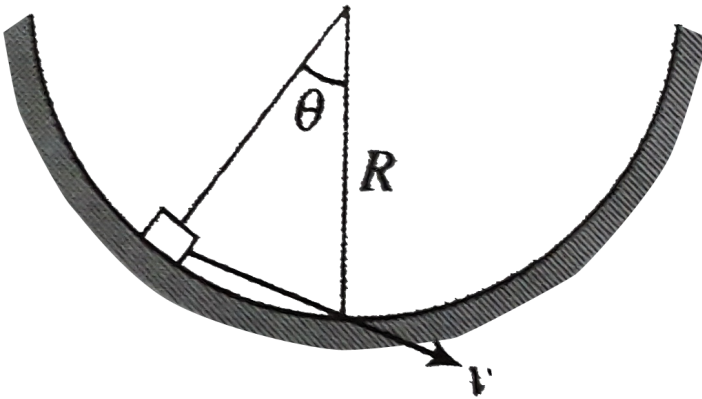

50. A particle of mass m is moving with a constant speed v in a circular path in a smooth horizontal plate (plan of the paper) by a spring force as shown in figure
If the natural length of the spring is l_0 and stiffness of the spring is k find the elongation of the spring

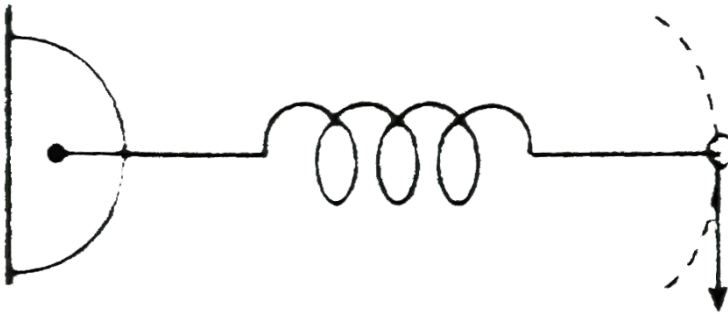

[Watch Video Solution](#)

51. A hemispherical bowl of radius R is rotating about its axis of symmetry which is kept vertical. A small ball

kept in the bowl rotates with the bowl without slipping on its surface. If the surface of the bowl is smooth and the angle made by the radius through the ball with the vertical is α . Find the angular speed at which the bowl is rotating.



[Watch Video Solution](#)

52. A block of mass m is pulled by a constant power P placed on a rough horizontal plane. The coefficient of friction between the block and surface is μ . Find the maximum velocity of the block.



[Watch Video Solution](#)

53. A block of mass M is connected with a particle of mass m by a light inextensible string as shown in fig. Assuming all contact surfaces as smooth, find the acceleration of the wedge after releasing the system.

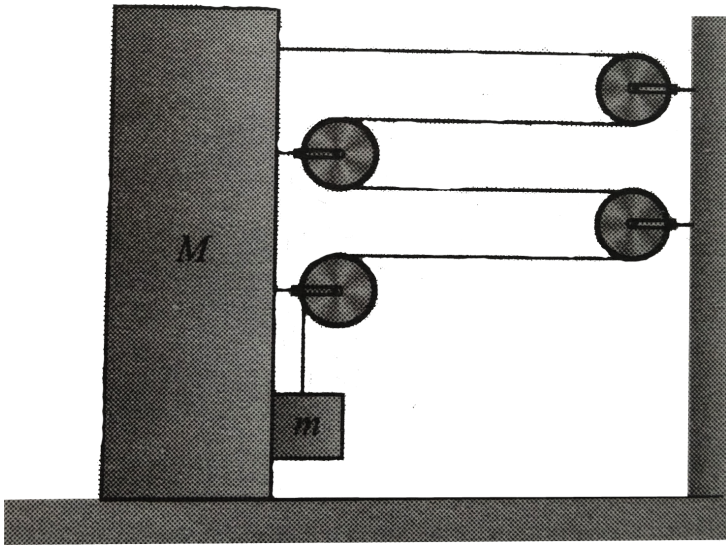

[Watch Video Solution](#)

54. In fig two block of mass m_A and m_B are rotating at radius r kept on a rough table consider friction (μ) between all the contact surface pulley is frictionless determine the angular speed of the turn table for which the blocks just begin to slide

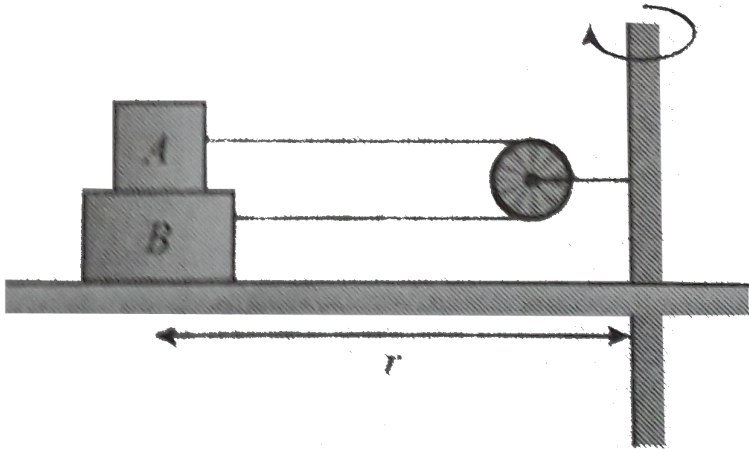

[Watch Video Solution](#)

55. An inclined plane of angle α is fixed onto a horizontal turntable with its line of greater slope in same plane as a diameter of turntable. A small block is placed on the inclined plane a distance r from the axis. The coefficient of friction between the block and the inclined plane is μ . The turntable along with inclined plane spins about its axis with constant minimum angular velocity ω .

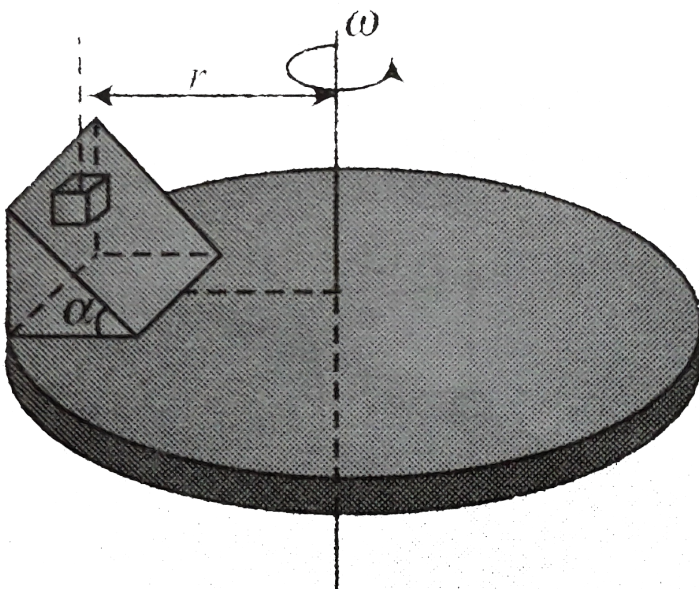

a. Find an expression for the minimum angular velocity ω to prevent the block from sliding down the plane in terms of g , r , μ and the angle θ

b. Now a block of mass m but having coefficient of friction 2μ is kept instead of the original block. Find the radius of friction force acting between block and incline now to the friction force active in part (a)



[Watch Video Solution](#)

56. A motorcycle has to move with a constant speed on an overbridge which is in the form of a circular arc of radius R and has a total length L . Suppose the motorcycle starts from the highest point.

a. what can its maximum velocity be for which the contact with the road is not broken at the highest point?

b. If the motorcycle goes at speed $\frac{1}{\sqrt{2}}$ times the maximum found in part a. where will it lose the contact with the road?

c. What maximum uniform speed can it maintain on the bridge if it does not lose contact anywhere on the bridge?



[Watch Video Solution](#)

57. A coin is pushed down tangentially from position θ on a cylindrical surface with a velocity v as shown in Fig.

If the coefficient of friction between the coin and surface is μ find the tangential acceleration of the coin

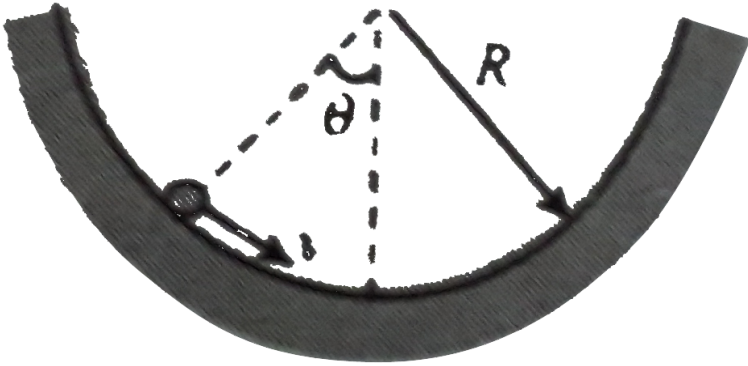

Watch Video Solution

58. In the situation shown in fig

a. What minimum force F will make any part or whole system move?

b. Find the acceleration of two blocks and value of

friction at the two surface if $F = 6N$

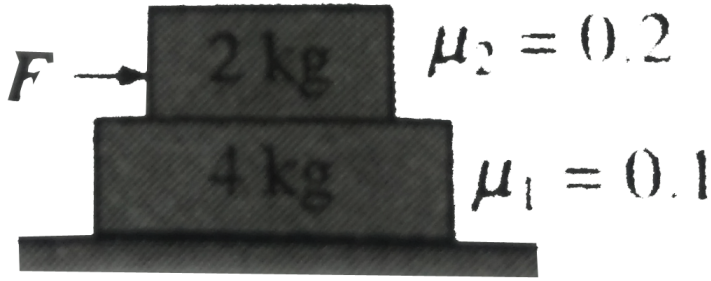

[Watch Video Solution](#)

59. A block of mass $1kg$ is tied to a string of length $1m$ the other end of which is fixed The block is moved on a smooth horizontal table with constant speed $10ms^{-1}$. Find the tension in the string

[Watch Video Solution](#)

Solved Examples

1. In the figure masses m_1 , m_2 and M are 20 kg, 5kg and 50kg respectively. The coefficient of friction between M and ground is zero. The coefficient of friction between m_1 and M and that between m_2 and ground is 0.3. The pulleys and the strings are massless. The string is perfectly horizontal between P_1 and m_1 and also between P_2 and m_2 . The string is perfectly vertical between P_1 and P_2 . An external horizontal force F is applied to the mass M . Take $g = 10m / s^2$.

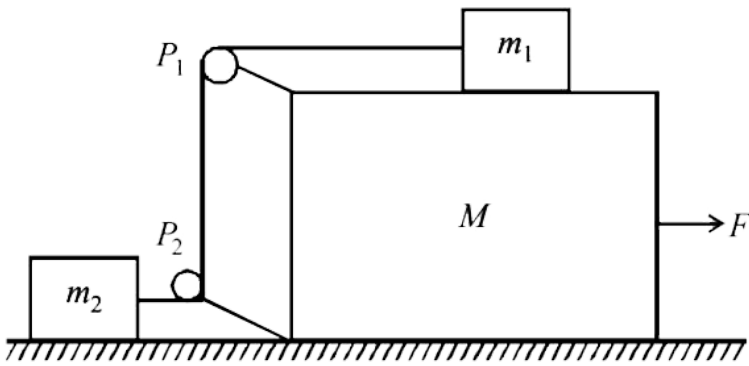

(a) Draw a free body diagram for mass M , clearly showing all the forces.

(b) Let the magnitude of the force of friction between m_1 and M be f_1 and that between m_2 and ground be f_2 . For a particular F it is found that $f_1 = 2f_2$. Find f_1 and f_2 . Write equations of motion of all the masses.

Find F , tension in the spring and acceleration of masses.

 [Watch Video Solution](#)

2. Blocks A , B and C are placed as shown in Fig and connected by the ropes of negligible mass . Both A and B weigh 25.0N each , and the coefficient of kinetic friction between each and the surface is 0.35 blocks C descends with constant velocity .

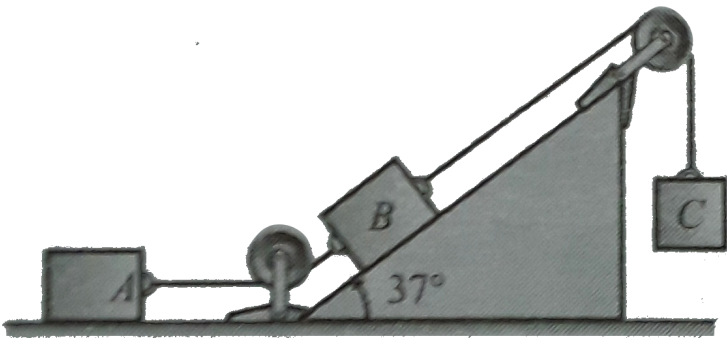

- a. Draw two separate free-body diagrams showing the forces acting on A and B
- b. Find the tension in the rope connecting blocks A and B
- c. What is the weight of blocks C ?
- d. If the rope connecting A and B were cut, what would be the acceleration of C ?



[Watch Video Solution](#)

3. Two blocks A and B of equal masses are placed on rough inclined plane as shown in Fig. When and where will the two blocks come on the same line on the inclined plane if they are released simultaneously? Initially the blocks A is $\sqrt{2}m$ behind the block B

.Coefficient of kinetic friction for the block A and B are 0.2 and 0.3 respectively ($g = 10ms^{-2}$)

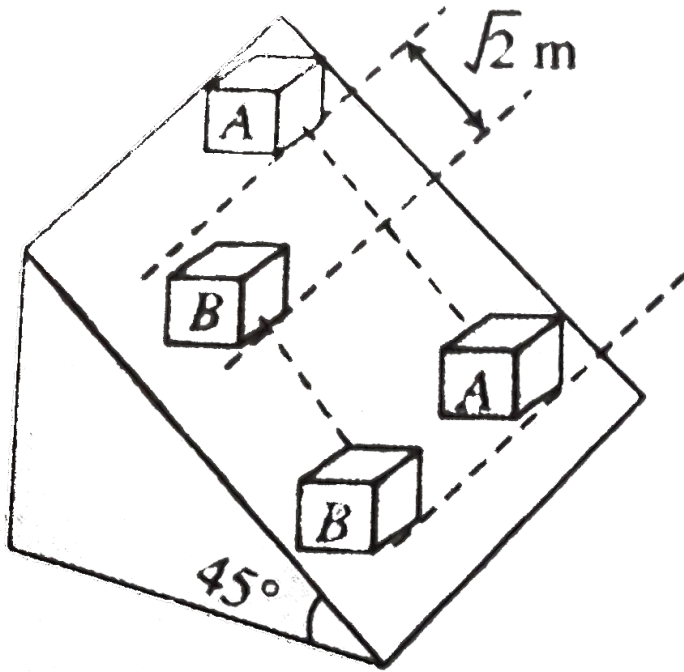

[▶ Watch Video Solution](#)

4. Find the acceleration a_1 , a_2 and a_3 of the three blocks shown in Fig if a horizontal force of $10N$ is

applied on

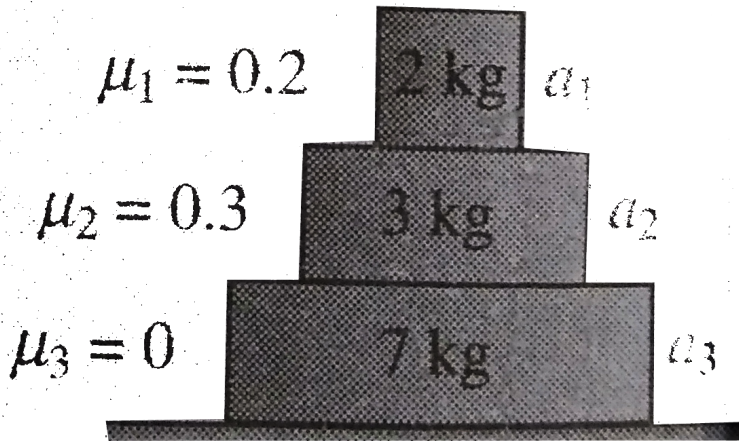

(a) 2kg blocks, (b) 3kg blocks and (c) 7kg blocks (Take $g = 10\text{ms}^{-2}$)

[Watch Video Solution](#)

5. In the situation shown in figure there is no friction between 2kg and ground.

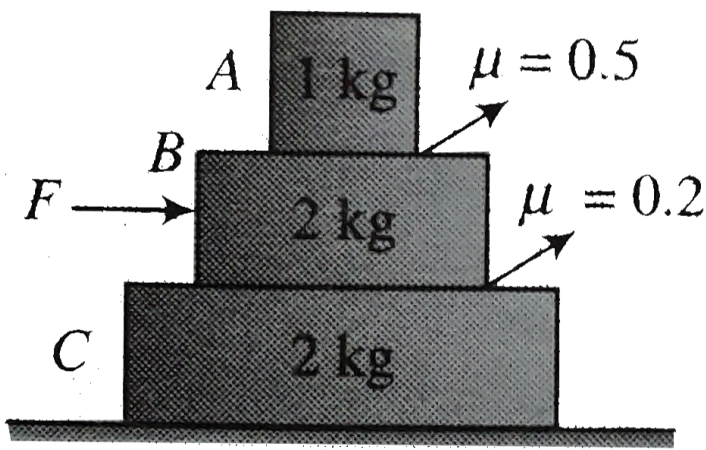

- For what maximum value of force F can all three blocks move together?
- Find the value of force F at which sliding starts at other rough surfaces.
- Find acceleration of all blocks, nature and value of friction force for the following values of force F (i) $10N$ (ii) N and (iii) $25N$



Watch Video Solution

6. Consider three blocks placed one over the other as shown in Fig. Let us now pull the blocks with the force of magnitudes $18N$, $100N$ and $15N$. Take $m_1 = m_2 = m_3 = 10kg$. If the coefficient of static and kinetic friction between all contacting surfaces are $\mu_s = 0.2$ respectively find the

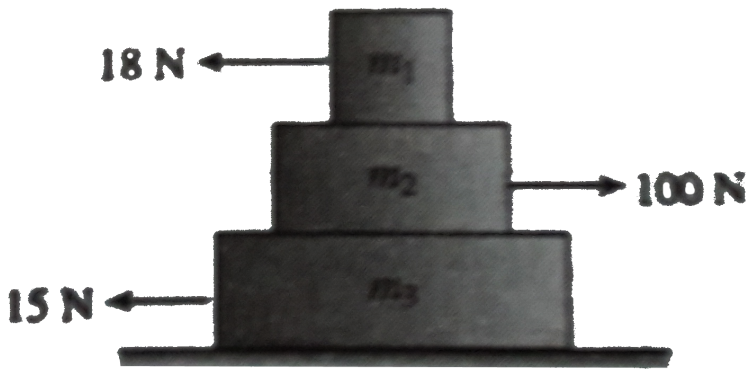

(a) Acceleration of the blocks

(b) Friction at each surface



[Watch Video Solution](#)

7. A track consists of two circular parts ABC and CDE of equal radius 100 m and joined smoothly as shown in figure. Each part subtends a right angle at its centre. A cycle weighing 100 kg together with rider travels at a constant speed of 18 km/h on the track. A. Find the normal contact force by the road on the cycle when it is at B and at D. b. Find the force of friction exerted by the track on the tyres when the cycle is at B, C and D. c. Find the normal force between the road and the cycle just before and just after the cycle crosses C. d. What should be the minimum friction coefficient between the road and the tyre, which will ensure that the cyclist can

move with constant speed? Take $g = 10 \frac{m}{s^2}$

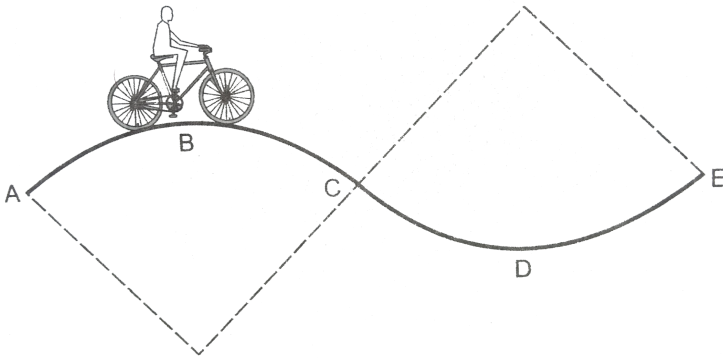

Figure 7-E1



Watch Video Solution

8. Two blocks $A(m_A = 5kg)$ and $B(m_B = 15kg)$ are placed as shown in Fig A variable force $F = 200$ starts acting from time $t = 0$ on lower block B just large enough to Determine the force F to make block B sliding out from between the blocks A and the ground at this instant , plot a graph between acceleration of

both the blocks and time

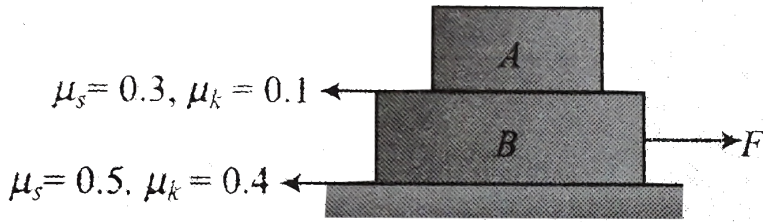

Watch Video Solution

9. A block of mass $m_1 = 20\text{kg}$ is placed on a wedge of mass $m_2 = 30\text{kg}$ which rests on a smooth floor as shown in Fig (a). Friction exists between block and wedge.

a. Find the acceleration of each block if (i) $F = 180\text{N}$ and (ii) $F = 400\text{N}$

b. Solve the problem if force $F = 180\text{N}$ is in the direction

upwards as shown in Fig (b)

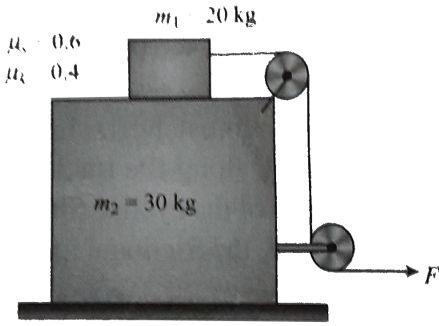

(a)

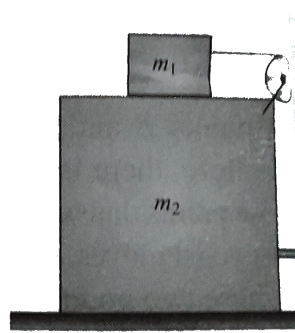

(b)

[Watch Video Solution](#)

10. Consider the situation shown in Fig. The horizontal surface below the bigger block is smooth the coefficient of friction between the block is μ find the minimum and the maximum force F that can be applied in order to keep the smaller blocks at rest with

respect to the bigger block

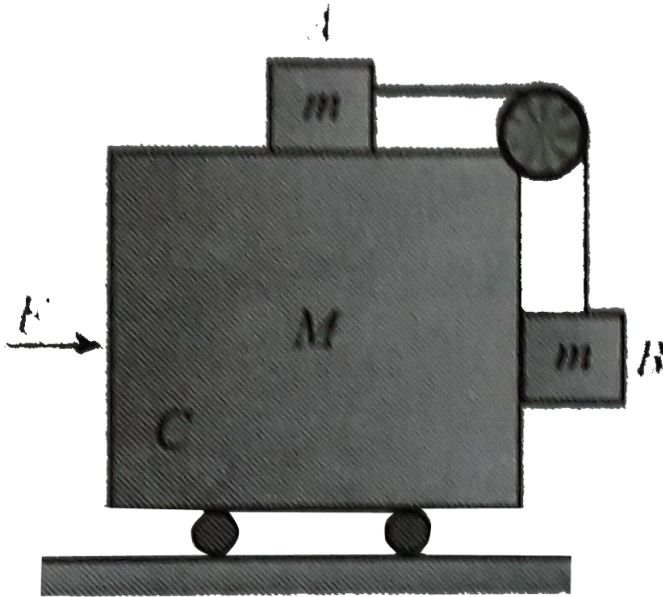

[Watch Video Solution](#)

11. A metal ring of mass m and radius R is placed on a smooth horizontal table and is set rotating about its own axis in such a way that each part of the ring moves with a speed v . Find the tension in the ring.



[Watch Video Solution](#)

12. A thin uniform copper rod of length l and mass m rotates uniformly with an angular velocity ω in a horizontal plane about a vertical axis passing through one of its ends. Determine the tension in the rod as a function of the distance r from the rotation axis. Find the elongation of the rod.



[Watch Video Solution](#)

Exercise 7.1

1. A block weighing $20N$ rests on a horizontal surface .
The coefficient of static friction between the block and surface is 0.4 and the coefficient of kinetic friction is 0.20

- a. How much is the friction force exerted on the block?
- b. How much will the friction force be if a horizontal force of $5N$ is exerted on the block?
- c. What is the minimum force that will start the block in motion ?
- d. What is the minimum force that will keep the block in motion once it has been started ?
- e. If the horizontal force is $10N$ what is the friction force?



[Watch Video Solution](#)

2. A block of mass m rests on a rough floor . The coefficient of friction between the block and the floor is

μ

a. Two boys apply force P at an angle θ to the horizontal. One of them pushes the block , the other one pulls. Which one would require less efforts to cause impending motion of the block?

b. What is the minimum force required to move the block by pulling it ?

c. Shown that the block is pushes at a certain angle θ_0 it cannot be moved fro whatever the value of P be



[Watch Video Solution](#)

3. What is the value of friction f for the following value of applied force F ?

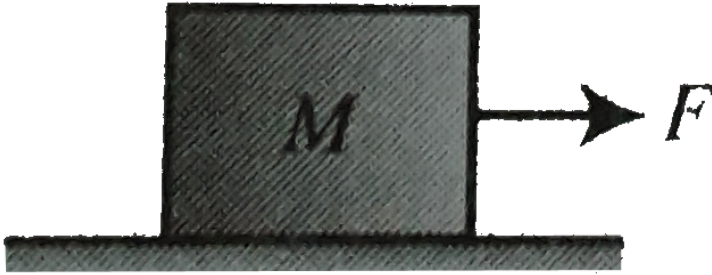

a. $1N$ b. $2N$ c. $3N$ d. $4N$ e. $20N$

Assume the coefficient of friction to be

$\mu_s = 0.3$; $\mu_k = 0.25$ Mass of the body is $m = 1kg$.

(Assume $g = 10ms^{-2}$)



Watch Video Solution

4. A block of mass 5kg rests on a rough horizontal surface. It is found that a force of 10N is required to make the block just move. However, once the motion begins, a force of only 8N is enough to maintain the motion. Find the coefficient of kinetic and static friction between the block and the horizontal surface.

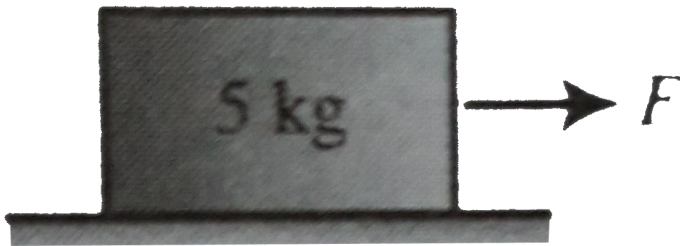

[Watch Video Solution](#)

5. A body of mass m is kept on a rough horizontal surface of friction coefficient μ . A force P is applied horizontally, but the body is not moving. Find the net force F exerted by the surface on the body.

 [Watch Video Solution](#)

6. Determine the magnitude of frictional force and acceleration of the block in each of the following cases :

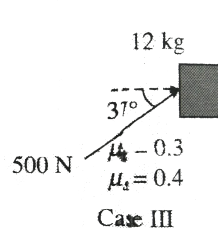
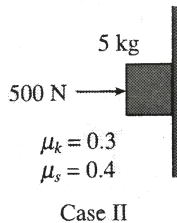
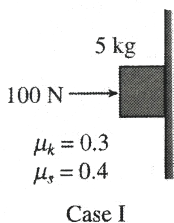

 [Watch Video Solution](#)

7. A 5 kg box is moving straight across the floor at a constant speed by a force of 30 N as shown in figure

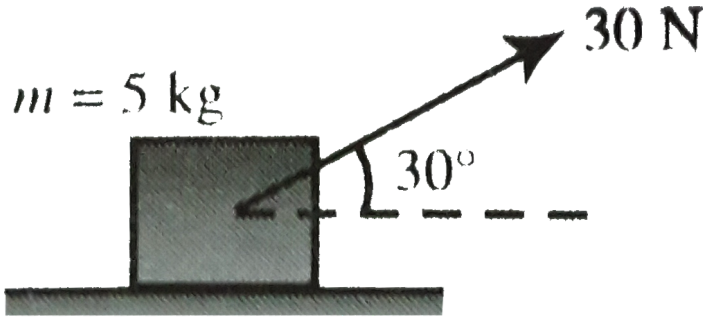

- How large a friction force impedes the motion of the box ?
- Find μ_k between the box and the floor

[Watch Video Solution](#)

8. A block of mass $m = 3\text{ kg}$ slides on a rough inclined plane of coefficient of friction 0.2 Find the resultant

force offered by the plane on the block

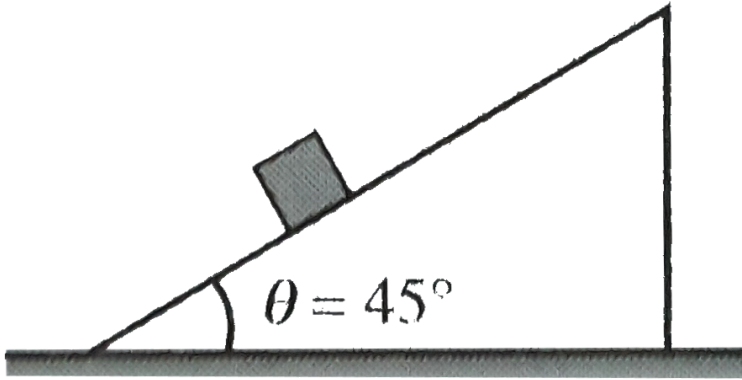

[▶ Watch Video Solution](#)

9. A block slides down on inclined plane (angle of inclination 60°) with an acceleration $g/2$ Find the

coefficient friction

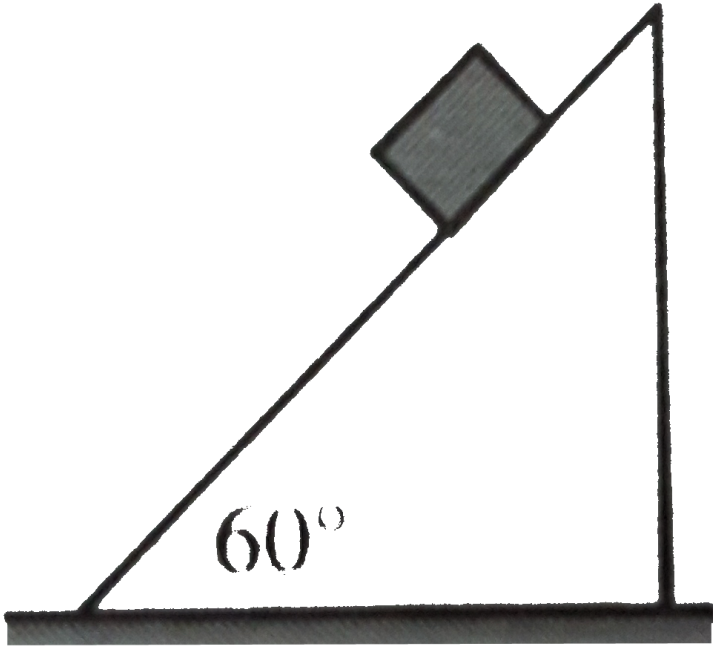

Watch Video Solution

10. An insect crawls up a hemispherical surface very slowly (see fig.). The coefficient of friction between the insect and the surface is $1/3$. If the line joining the

center of the hemispherical surface to the insect makes an angle α with the vertical, the maximum possible value of α is given by

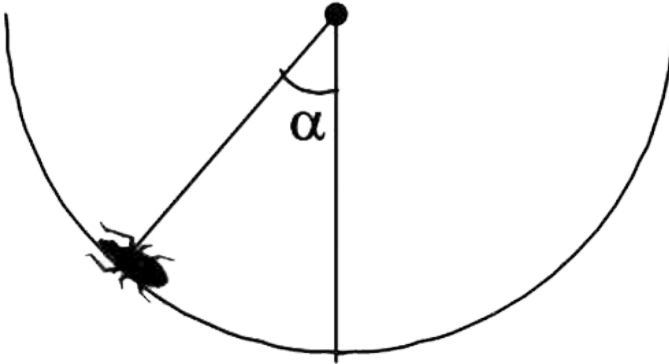

[Watch Video Solution](#)

11. In Fig if f_1 , f_2 and T are the friction forces on $2kg$ block $3kg$ block and tension in the string respectively the find their value initially before applying the forces

tension in string was zero

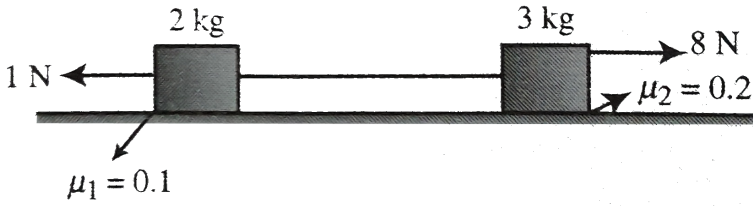

[▶ Watch Video Solution](#)

12. Find the friction on the 2 kg block in the arrangement shown in figure

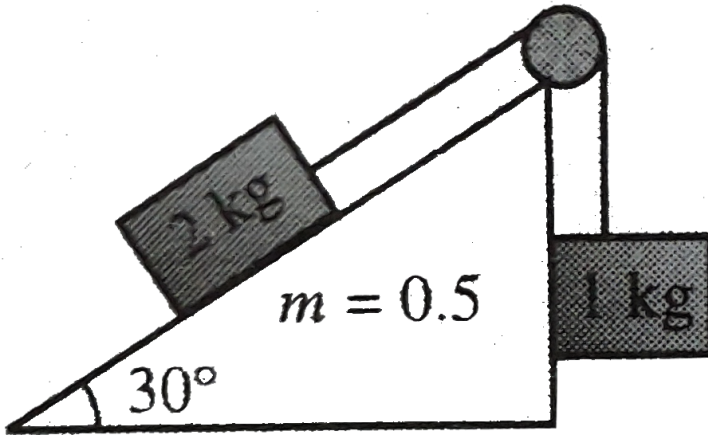

[▶ Watch Video Solution](#)

13. A goods train has 25 compartments. Will the tension in coupling between the fourth and fifth compartment be the same as that in the coupling between the 21st and the 22nd compartments ?



Watch Video Solution

14. A box of bananas weighing $40.0N$ rests on a horizontal surface is 0.40 and the coefficient of kinetic friction is 0.20

a. If no horizontal force is applied to the box and the box is at rest , how large is the friction force exerted on

the box ?

b. What is the magnitude of the friction forces if a monkey applies a horizontal force of $6.0N$ to the box and the box is initial at rest?

c. What minimum horizontal force must the monkey apply to start the box in motion ?

d. What minimum horizontal force must the monkey apply to keep the box moving at constant velocity once it has been starts?

e. If the monkey applies a horizontal force of $18.0N$ What is the magnitude of the friction force and what is the box's acceleration ?



[Watch Video Solution](#)

15. A mass of mass 60kg is pulling a mass M by an inextensible light rope passing through a smooth and massless pulley as shown in figure. The coefficient of friction between the mass and ground is $\mu = 1/2$ find the maximum value of M that can be pulled on the ground



 [Watch Video Solution](#)

16. a. Block A , as shown in figure weight 60.0N The coefficient of static friction between the block and the surface on which it rest is 0.25 .The waight w is 12N The system is in equilibrium .Find the friction for exerted on block A

b. Find the maximum weight w for which the system will remain in equilibrium



[Watch Video Solution](#)

17. If the coefficient of friction between M and the inclined surfaces is $\mu = 1/\sqrt{3}$ find the minimum mass m of the rod so that the of mass $M = 10kg$ remain

stationary on the inclined plane

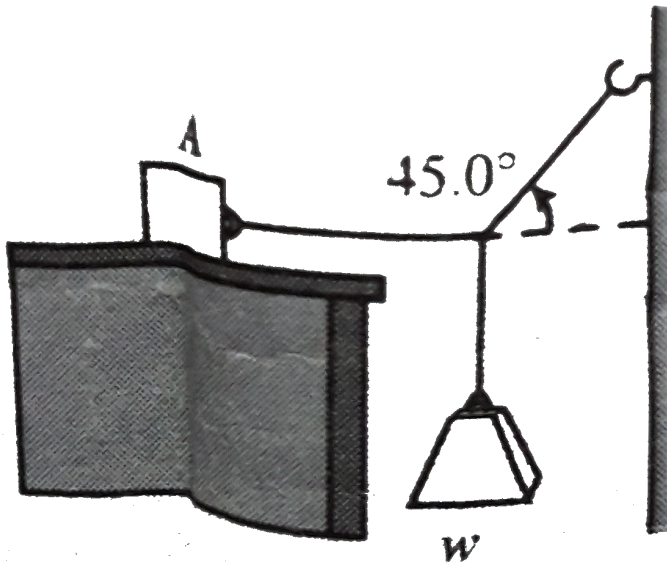

[Watch Video Solution](#)

18. A block of mass m is placed on an inclined plane. With what acceleration A towards right should the system move on a horizontal surface so that m does not slide on the surface of inclined plane? Also

calculate the force supplied by wedge on the block.

Assume all surfaces are smooth.

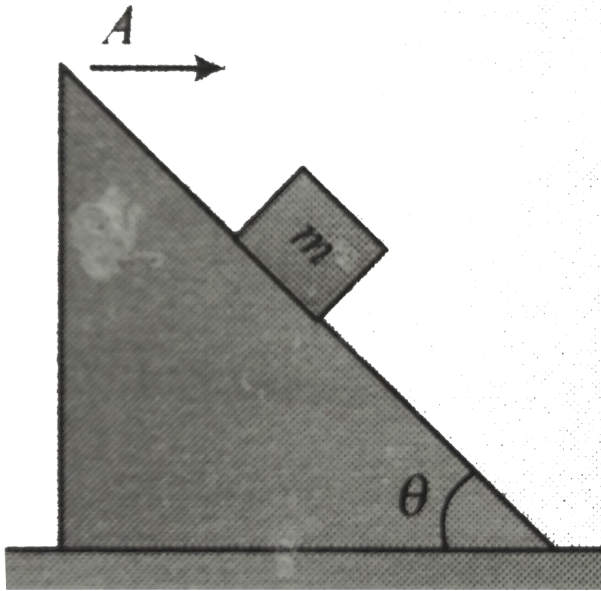

[Watch Video Solution](#)

19. A block of mass $5kg$ rests on a rough horizontal surface. It is found that a force of $10N$ is required to make the block just move. However, once the motion

begins, a force of only $8N$ is enough to maintain the motion find the coefficient of kinetic and static friction between the block and the horizontal surface

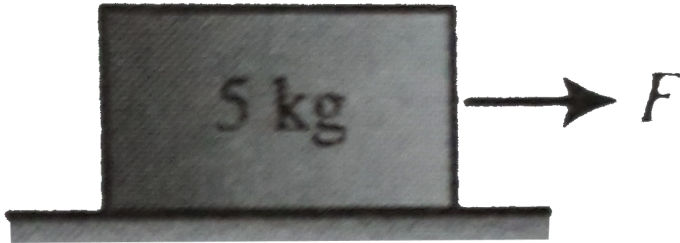

[Watch Video Solution](#)

20. A thin rod of length $1m$ is fixed in a vertical position inside a train, which is moving horizontally with constant acceleration $4ms^{-2}$. A bead can slide on the rod and friction coefficient between them is 0.5 . If the

bead is released from rest at the top of the rod , it will reach the bottom in



[Watch Video Solution](#)

21. With what minimum velocity should be projected from left end A toward end B such that it reaches the other end B of conveyer belt moving with constant velocity v The friction coefficient between block and

belt is μ

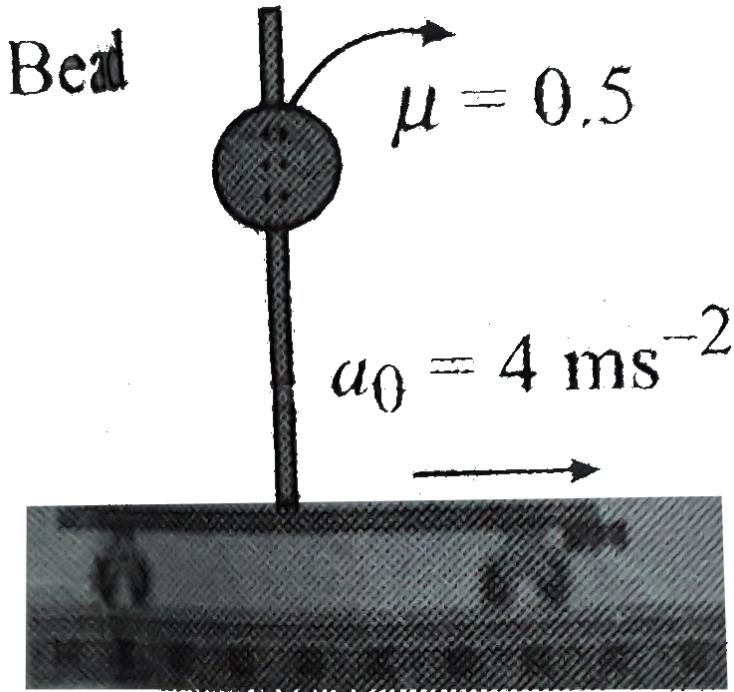

Watch Video Solution

22. A block mass $m = 2\text{kg}$ is accelerating by a force $F = 20\text{N}$ applied on a smooth light pulley as shown in fig 7.86 If the coefficient of kinetic friction between the

block and the surface is $\mu = 0.3$ find its acceleration

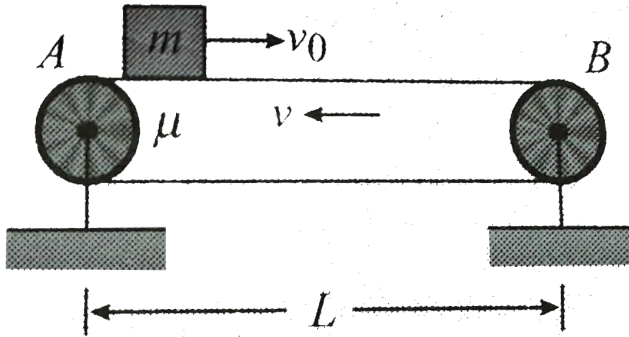

[Watch Video Solution](#)

23. A uniform chain of length L and mass M overhangs a horizontal table with its two third part on the table. The friction coefficient between the table and the chain is μ . Find the work done by the friction during the period the chain slips off the table.

[Watch Video Solution](#)

24. Two small spheres of masses m_1 and m_2 are connected by a light rigid rod. The system is placed between a rough floor and smooth vertical wall as shown in Fig. The coefficient of friction between the floor and the sphere of mass m_2 is μ . Find the minimum value of θ so that the system of masses does not slip



[Watch Video Solution](#)

25. Two blocks of masses m_1 and m_2 connected by a string and placed on a rough inclined plane having coefficient of friction μ is shown in fig 7.89 Find the

ratio of masses m_1 / m_2 so that

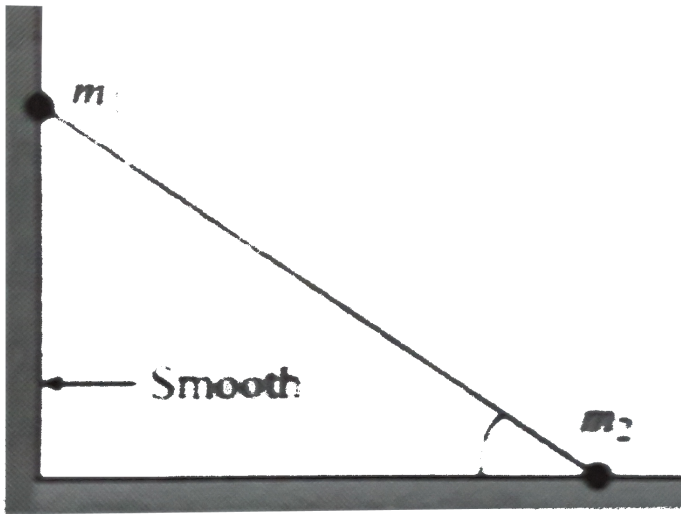

- a. the block m_1 start moving downward
- b. the block m_1 start moving upward
- c. no motion takes place



Watch Video Solution

1. A block of mass 1kg is horizontal thrown with a velocity of 10m s^{-1} on a stationary long of mass 2kg whose surface has a $\mu = 0.5$. Plane rest on friction surface find the time when m_1 comes to rest w.r.t. plane

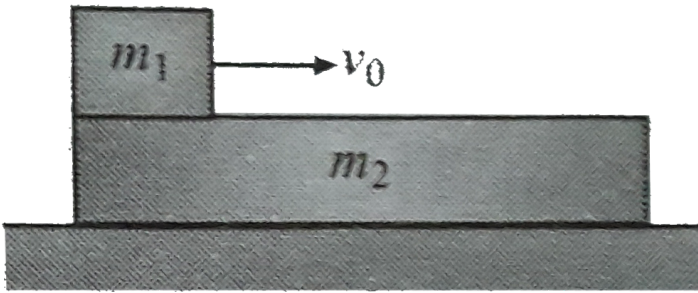

[Watch Video Solution](#)

2. In Fig. initially the system is at rest .Find out minimum value of F for which sliding start between the two

blocks Given $m_A = 10\text{kg}$ and $m_B = 20\text{kg}$



[Watch Video Solution](#)

3. Find the acceleration of the two blocks . The system is initially at rest and the friction are as shown in fig

.Given $m_A = m_B = 10\text{kg}$

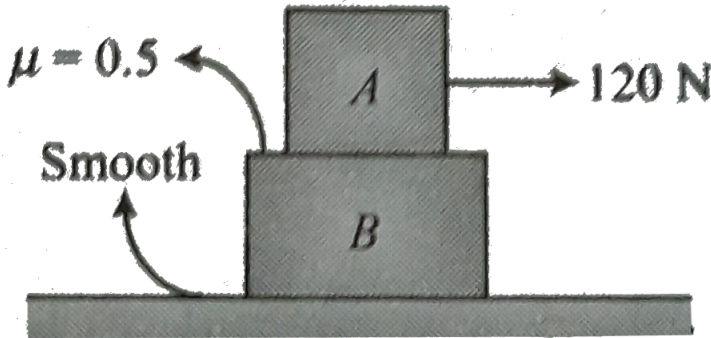

[Watch Video Solution](#)

4. Find the acceleration of the two blocks . The system is initially at rest and the friction are as shown in fig

.Given $m_A = m_B = 10\text{kg}$

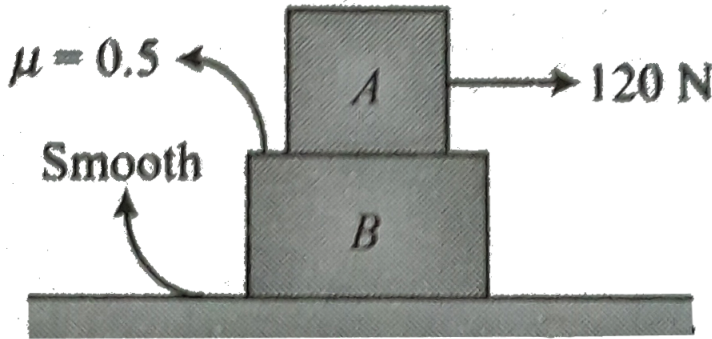

[Watch Video Solution](#)

5. Find the acceleration of the two blocks The system initially at rest and the friction coefficient are as shown in fig 7.140? Also find maximum F for which two blocks

will move together Given $m_A = 10\text{kg}$ and $m_B = 20\text{kg}$

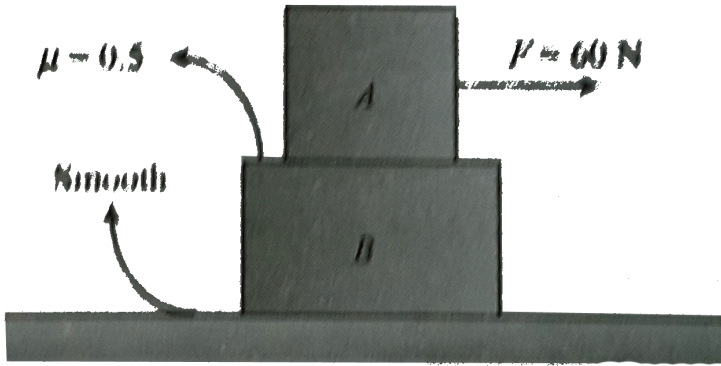

Watch Video Solution

6. The block A is kept over a plan B. The maximum horizontal acceleration of the system in order to prevent slipping of A over B is $a = 2\text{ms}^{-2}$ find the

coefficient of friction between A and B

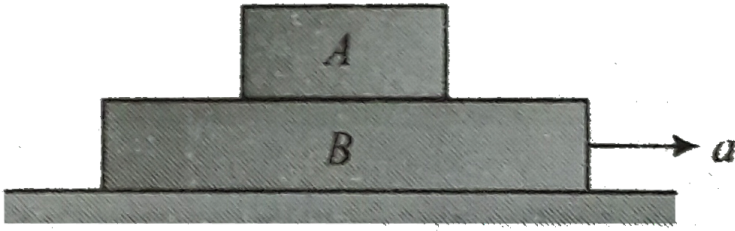

[Watch Video Solution](#)

7. Figure shown a small block A of mass m kept at the left end of a plank B of mass $M = 2m$ and length l . The system can slide on a horizontal road. The system is started towards right with the initial velocity v . The friction coefficient between the road and the plank is $1/2$ and that between the plank and the block is $1/4$. Find

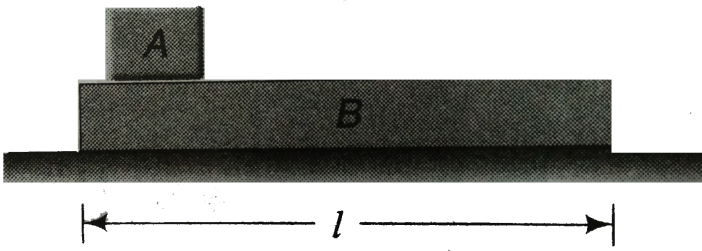

- (a) the time elapsed before the block separates from the plank
- (b) displacement of block and plank relative to ground till that moment.

 [Watch Video Solution](#)

8. A small block of mass m is placed on a plank of mass M . The block is connected to plank with the help of a light string passing over a light smooth pulley shown in fig. The co-efficient of static friction between the plank

is μ The co-efficient of friction between the plank and the maximum horizontal force F applied on the block of mass m can make block not to slide relatively?

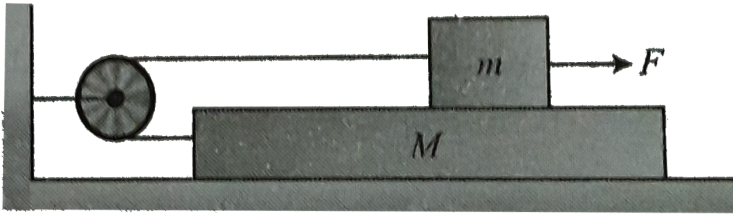

[Watch Video Solution](#)

9. Two block A and B are arranged as shown in figure ($m_A = 5kg$ and $m_B = 10kg$) Find the acceleration of

blocks if $F = 40N$

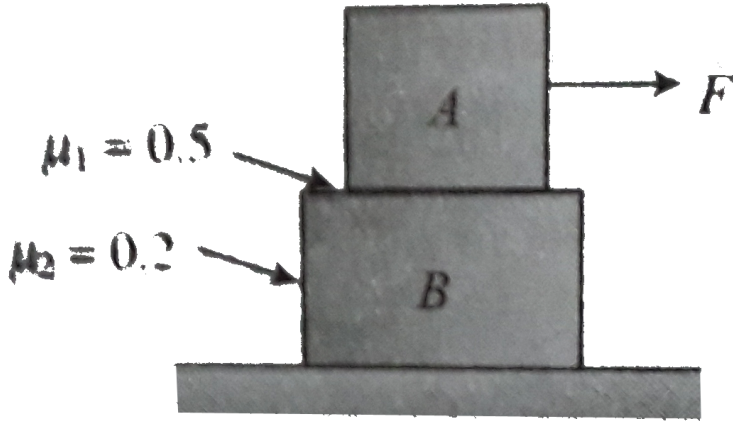

[Watch Video Solution](#)

10. In Fig block 1 is placed on top of block 2 .Both of then have a mass of $1kg$ The coefficient of friction between block 1 and 2 are $\mu_s = 0.75$ and $\mu_k = 0.60$ The table is frictionless A force $p/2$ is applied on block 1 in the left and force P on block 2 to the right .Find

the minimum value of p such that sliding accore
between the two blocks

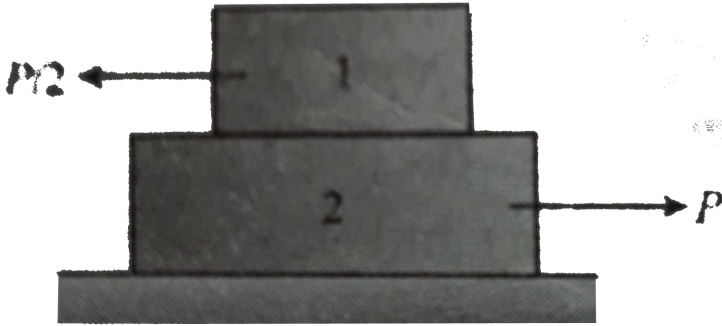

[Watch Video Solution](#)

11. A mass of $80kg$ stands on a horizontal weight machine of negligible mass , attched to a massless platform P that sliding down at 37° incline. The ewight machine reads $72kg$ the man is always at rest weight machine calculate

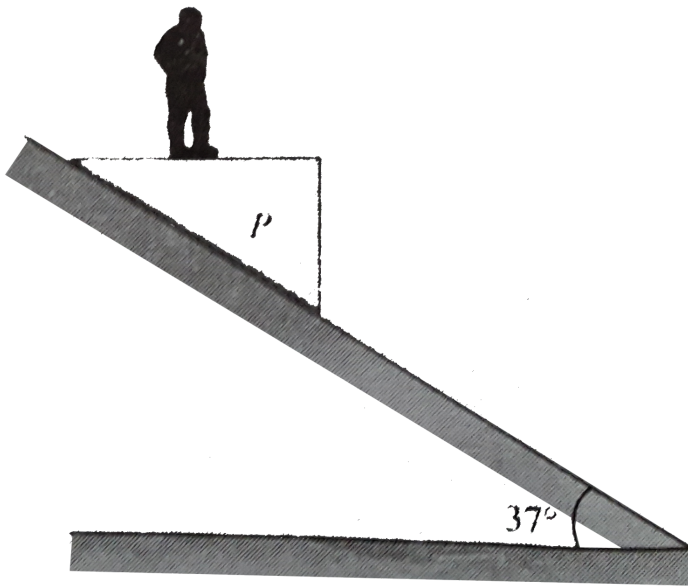

a. the vertical acceleration of the man.

b. the coefficient of kinetic friction μ between platform and incline.

[▶ Watch Video Solution](#)

12. A block of mass 1kg is horizontal thrown with a velocity of 10ms^{-1} on a stationary long of mass 2kg

whose surface has a $\mu = 0.5$. Plane rest on friction surface find the time when m_1 comes to rest w.r.t. plane

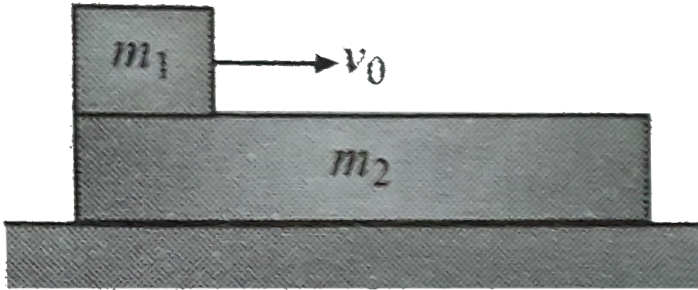

[Watch Video Solution](#)

13. In figure the coefficient of friction between the floor and the block B is 0.1. The coefficient of friction between the block B and A is 0.2. The mass of A is $m/2$ and B is m . What is the maximum horizontal force F can be applied

to the block B so that two blocks move together?

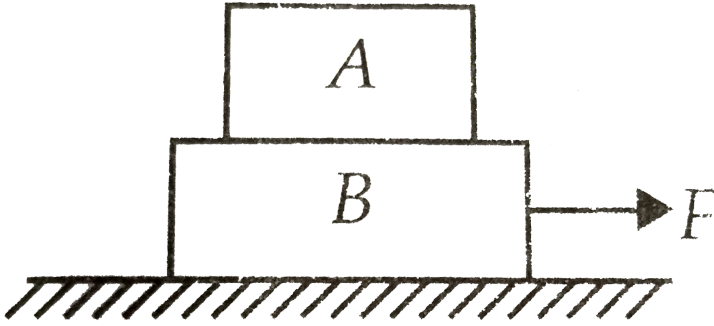

[Watch Video Solution](#)

14. Find minimum normal force to be each hand to hold there identical books in verticle position Each books has mass m and the value of coefficient of friction between the books as well as between hand and the

book is μ

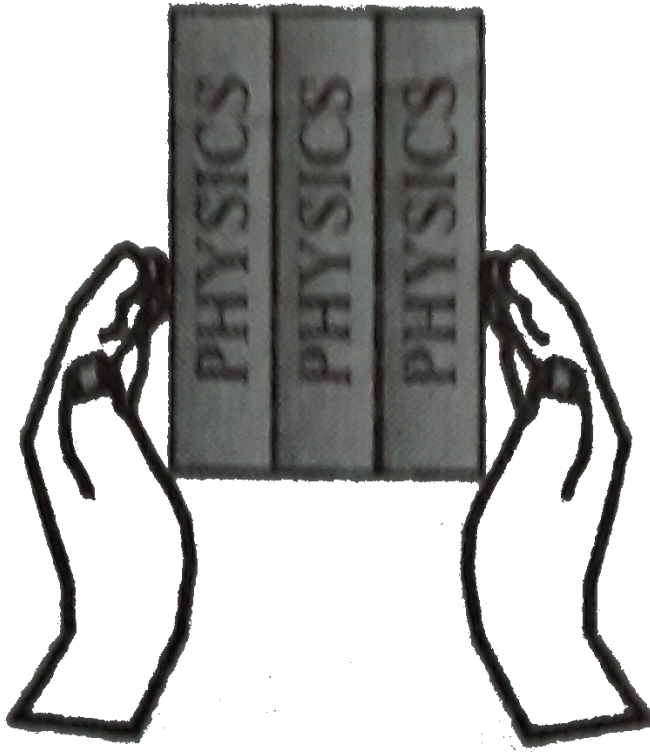

Watch Video Solution

15. A plank of mass M is placed on a rough horizontal surface μ and a constant horizontal force F is applied on

it . A man of mass m runs on the plank find the range of acceleration of the man that the plank does not move on the surface. Coefficient of friction between the plank and the surface is μ .Assume that the man does not slip on the plank

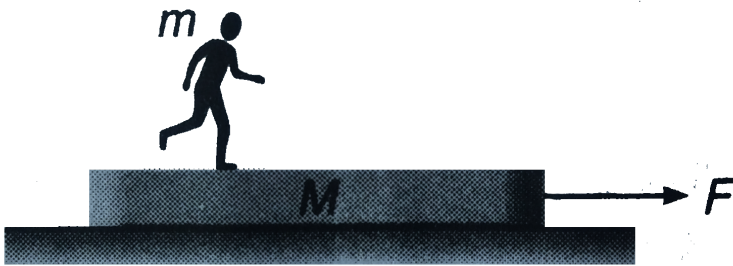

[Watch Video Solution](#)

16. A man of mass m is moving with a constant acceleration a w.r.t plank is .The plank lies on a smooth horizontal floor If the mass of plank M then calculate

the acceleration of plank and man w.r.t ground and
frictional force extended by plank on man

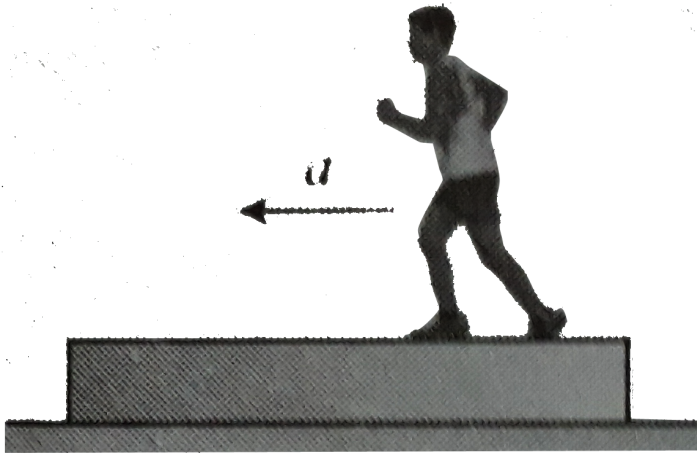

[▶ Watch Video Solution](#)

Exercise 7.3

1. Three masses are attached to strings rotating in the horizontal plank. The string pass over two pulleys as

shown in fig will this system be in equilibrium

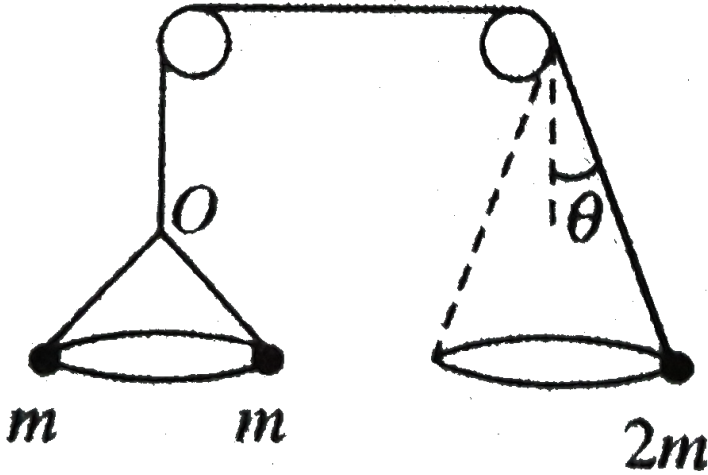

[▶ Watch Video Solution](#)

2. Can force determine the direction of motion ?

Direction of acceleration ?

[▶ Watch Video Solution](#)

3. You are riding on a Ferris wheel that is rotating with a constant speed. The car in which you are riding always maintains its correct upward orientation, it does not invert.

a. What is the direction of the normal force on you from the seat when you are at the top of the wheel?

i. upward ii. downward iii. impossible to determine

b. From the same choices, what is the direction of the net force on you when you are at the top of the wheel?



[Watch Video Solution](#)

4. A bead slides freely along a curved wire lying on a horizontal surface at constant speed as shown in Fig

a. Draw the vectors representing the force exerted by the wire on the bead at point A ,B and C

b. Suppose the bead in figure speeds up with constant tangential acceleration as it moves toward the right

Draw the vector representing the force on the bead at point A B and C

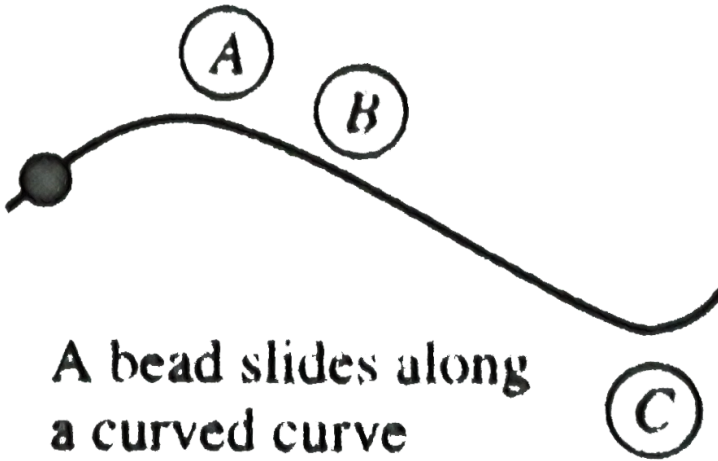

[Watch Video Solution](#)

5. A smooth block loosely fits in a circular tube placed on a horizontal surface . The block moves along the tube (fig) Which wall (inner or outer) will exert a non zero normal contact force on the block?

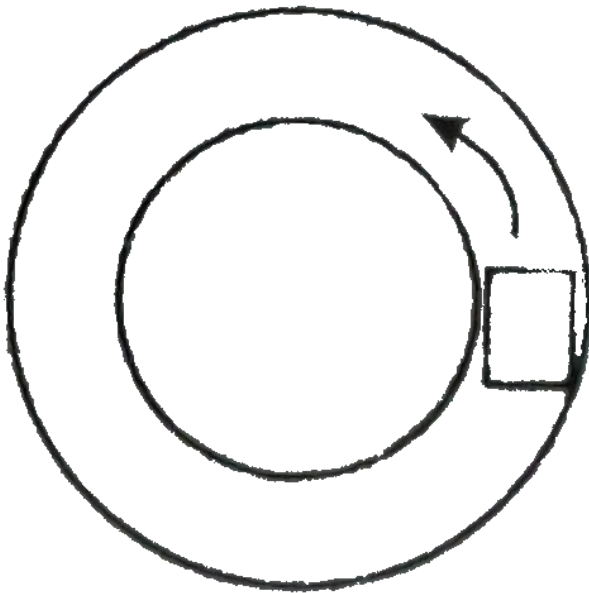

[Watch Video Solution](#)

6. An amusement park ride consist of a large verticle cylinder that spins about its axis first fast enough that any person inside is held up against the wall when the is μ_s and the radius of the cylider is R



a. Shown that maximum period of revolution neccessary

to keep the person from falling is $T = (4\pi^2\mu_s R/g)^{1/2}$

b. Obtain a numerical value for T taking $R = 4.00m$

and $\mu_s = 0.400$. How many revolutions per minute

does the cylinder make?

c. If the rate of revolution of the cylinder is make to be

some what larger what happens to the magnitude of

each one of the forces acting on the person ? What

happens to the motion of the person ?

d. If instead the cylinder rate revolution is made to be somewhat smaller what happens to the magnitude and what happens to the motion of the person ?



[Watch Video Solution](#)

7. Tarzan ($m = 85.0\text{kg}$) tries to cross a river by swinging on a vine . The vine is 10.0m just and his speed at the bottom of the swing (as he just clears the water) will be 8.00m s^{-1} Tarzan does not know that the vine has a breaking strength of 1000N Does he make it across the river safely ?



[Watch Video Solution](#)

8. A roller-coaster car a mass of 500kg when fully loaded with passengers

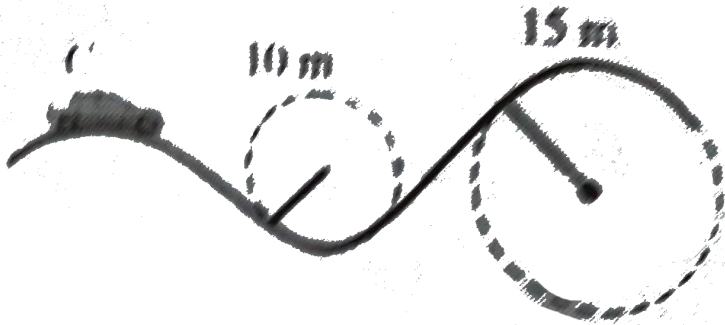

a. If the vehicle has a speed of 20.0ms^{-1} at point A what is the force exerted by the track on the car at this point ?

b. What is the maximum speed the vehicle can have at point B and still remain on the track?

 [Watch Video Solution](#)

9. An air puck of mass m_1 is tied to a string allowed to revolved in a circle of radius R on a frictionless horizontal table . The other end of the string passes through a small hole in the centre of the table , and a load of mass m_2 is tied to the string? The suspended load remains in equilibrium while the pack on the tabletop revolves.

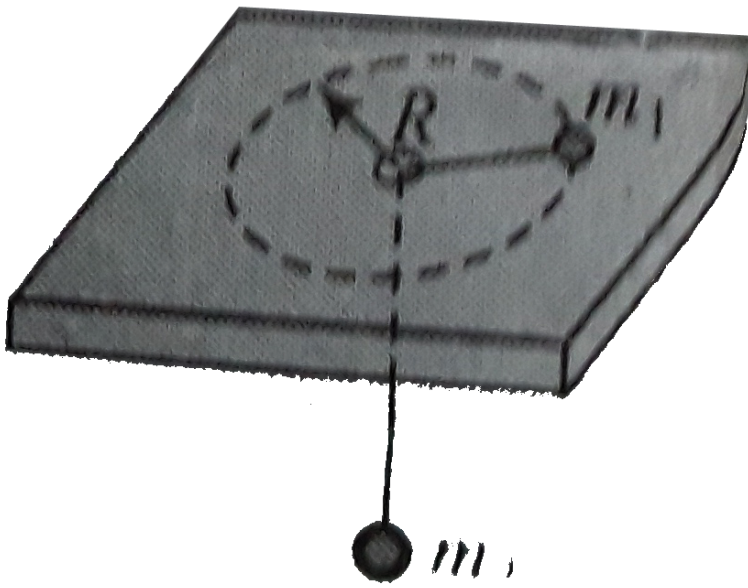

- a. Find the tension in the string
- b. Find the radial force acting on the puck
- c. Find the speed of the puck
- d. Qualitaively describe what will happen in the motion of the puck if the value of m_2 is somewhat increased by placing an additional load on it.
- e. Qualitaively describe what will happen in the motion of the puck if the value of m_2 is instead decreased removing a part from the hanging load.



[Watch Video Solution](#)

10. A sleeve A can slide freely along a smooth rod bent in the shape of a half circle of radius R . The system is set in rotaion with a constant angular velocity ω about

a vertical axis OO' . Find the angle θ corresponding to the steady position of the sleeve



 [Watch Video Solution](#)

11. A ball suspended by a thread swings in a vertical plane so that its acceleration in the extreme position and lowest position are equal. The angle θ of thread deflection in the extreme position will be

 [Watch Video Solution](#)

12. A simple pendulum is oscillating with angular displacement 90° . For what angle with vertical the acceleration of bob direction horizontal?



Watch Video Solution

13. A car moves at a constant speed of 56.4 km per hour. How much distance does it cover in 3.5 hours ?



Watch Video Solution

14. A block of mass m is kept on a horizontal ruler. The friction of coefficient between the ruler and the block is

μ . The ruler is fixed at one end and the block is at a distance L from the fixed end. The ruler is rotated about the fixed end in the horizontal plane through the fixed end. a. What can the maximum angular speed of the ruler b) if the angular speed of ruler is uniformly increased from zero to an angular acceleration α , at what angular speed will the block slip?

 [Watch Video Solution](#)

15. An old record player of 15.0cm radius at 33.0rev min^{-1} while mounted on a 30° incline as shown in figure

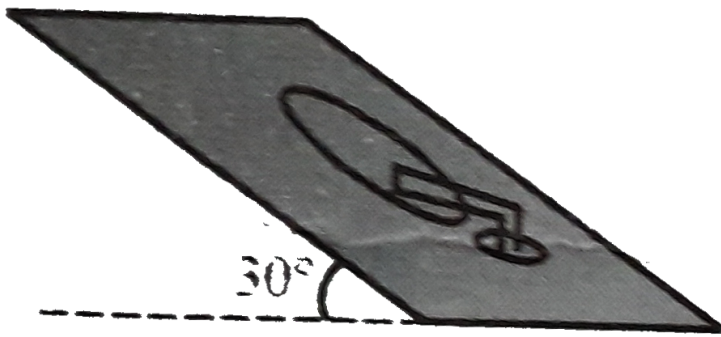

- a. If a mass m can be placed anywhere on the rotating record, where is the most critical place on the disc where slipping might occur?
- b. Calculate the least possible coefficient of friction that must exist if no slipping occurs.

 [Watch Video Solution](#)

16. A $60 - kg$ woman is on a large vertical swing of radius $20m$. The swing rotates with constant speed

- a. At what speed would she feel weightless at the top?
- b. At this speed what is her apparent weight at the bottom?



[Watch Video Solution](#)

17. A rod OA rotates about a horizontal axis through O with a constant anticlockwise velocity $\omega = 3 \text{ rad s}^{-1}$. As it passes the position $\theta = 0$, a small block of mass m is placed on it at a radial distance $r = 450 \text{ mm}$ if the block is observed to slip at $\theta = 50^\circ$. Find the coefficient of static friction between the block and the rod.

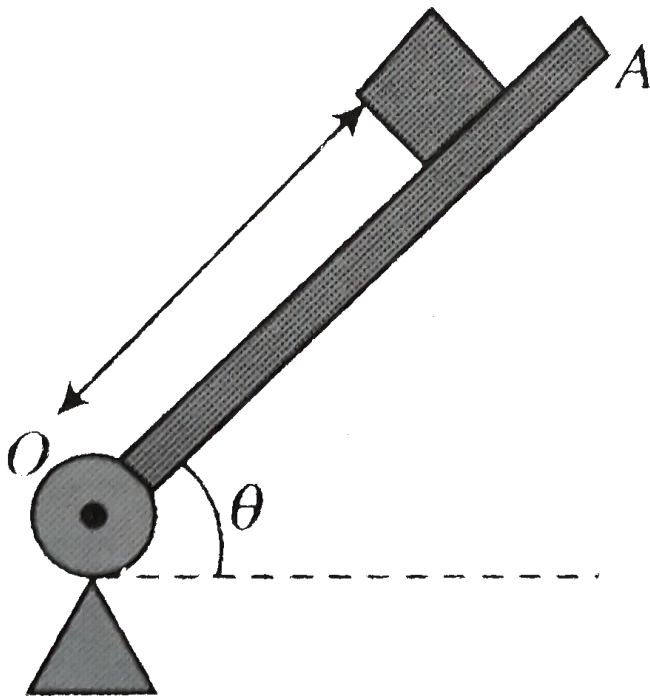

(Given that $\sin 50^\circ = 0.766$, $\cos 50^\circ = 0.64$)

[▶ Watch Video Solution](#)

18. A small mass m and its supporting wire because a simple pendulum when the horizontal cord is cut . Find

the ratio of the tension in the supporting wire immediately after the cord is cut to the tension in the wire before the cord is cut

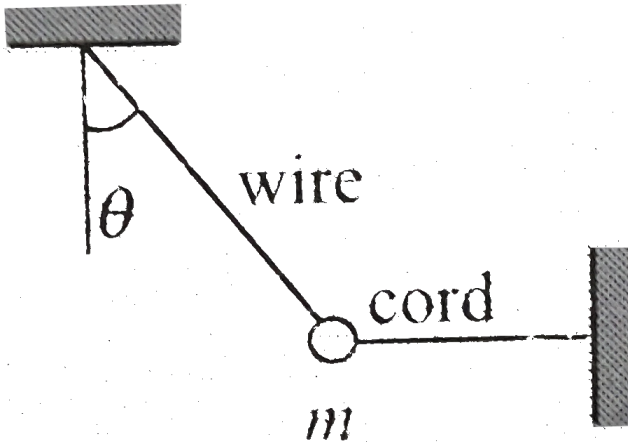

[Watch Video Solution](#)

19. A simple pendulum is constructed by attaching a bob of mass m to a string of length L fixed at its upper end. The bob oscillates in a vertical circle. It is found

that the speed of the bob is v when the string makes an angle α with the vertical. Find the tension in the string and the magnitude of net force on the bob at that instant.



[Watch Video Solution](#)

20. A car is moving with uniform speed over a circular bridge of radius R which subtends an angle of 90° at its center. Find the minimum possible speed so that the car can cross the bridge without losing the contact anywhere



[Watch Video Solution](#)

21. A block of mass m fitted with a light spring of stiffness k and natural length l_0 kept on a smooth radial groove made on a disc rotating with a constant angular axis. If the block is released slowly. Find the maximum elongation of the spring



 [Watch Video Solution](#)

22. A disc of radius R rotates from rest about a vertical axis with a constant angular acceleration such that a coin placed with a tangential between a as shown in figure. If the coefficient of static friction between the coin and disc is μ_s . Find the velocity of the before it

start sliding relative as the disc

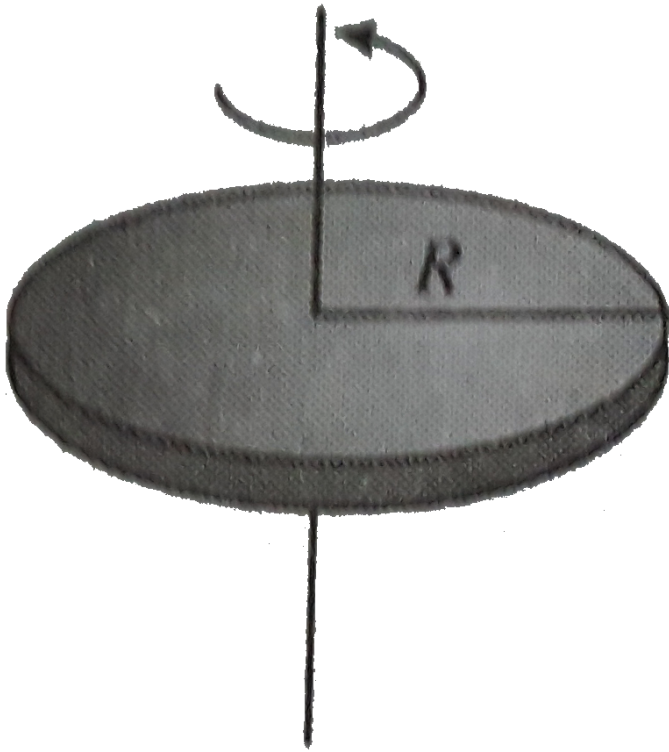

Watch Video Solution

23. There are two blocks of masses m_1 and m_2 , m_1 is placed on m_2 on a table which is rotating with an

angular velocity ω about the vertical axis . The coefficient of friction between the block is μ_1 and between m_2 and table is μ_2 ($\mu_1 < \mu_2$) if block are placed at distance R from the axis of rotation , for relative sliding between the surface in contact , find the

a. friction force at the contacting surface

b. maximum angular speed ω

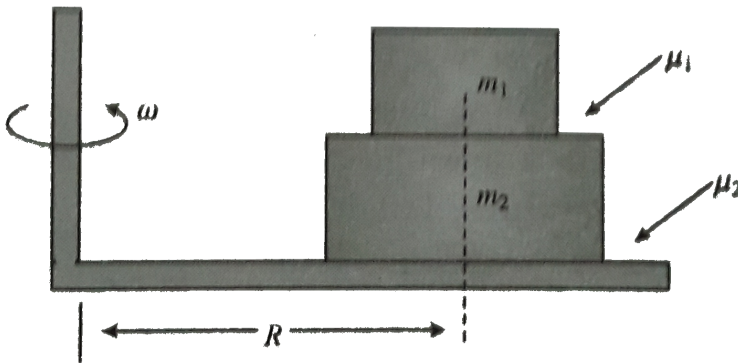

[Watch Video Solution](#)

24. A small wedge whose base is horizontal is fixed to a vertical rod as shown in fig . The sloping side of the wedge is frictionless and the wedge is spun with a constant angular speed ω about vertical axis as shown in the fig find the

a. value of angular speed ω for which the block of mass m just does not slide down the wedge.

b. normal reaction on the block by wedge when block

does not slip relative to wedge.

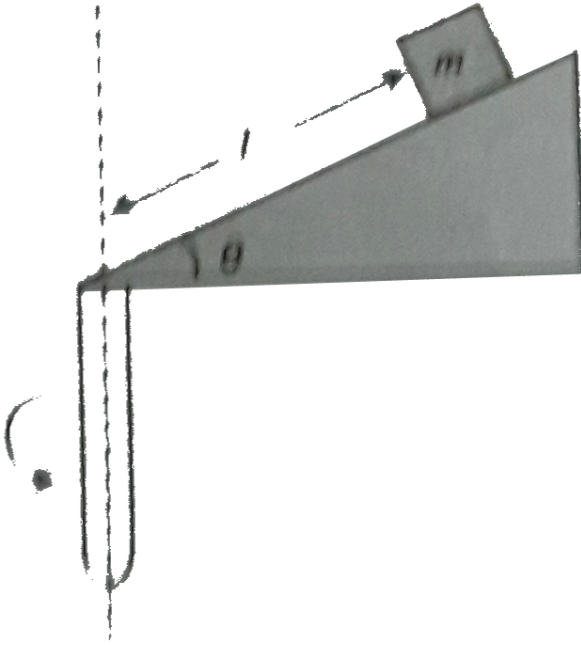

[Watch Video Solution](#)

25. A table with smooth horizontal surface is turning at an angular speed ω about its axis. A groove is made on the surface along a radius and a particle is gently

placed inside the groove at a distance a from the centre. Find the speed of the particle as its distance from the centre becomes L .

 [Watch Video Solution](#)

26. A table with smooth horizontal surface is fixed in a cabin that rotates with a uniform angular velocity ω in a circular path of radius R . A smooth groove AB of length L ($L < R$) is made on the surface of the table. The groove makes an angle θ with the radius OA of the circle in which the cabin rotates. A small particle is kept at the point A in the groove and is released to move along AB . Find the time taken by the particle to reach

the point B.

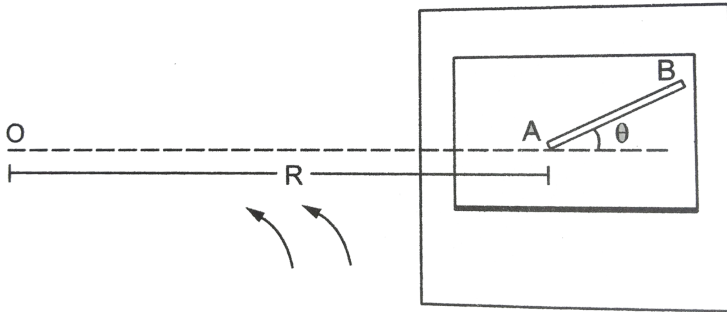

Figure 7-E3



[Watch Video Solution](#)

27. A child is swinging a ball of mass M around on a light spring which has spring constant k . The ball describes a horizontal circle. The stretched spring has a length l and makes an angle θ with the vertical as shown in fig. the acceleration due to gravity is g neglect

air resistance.

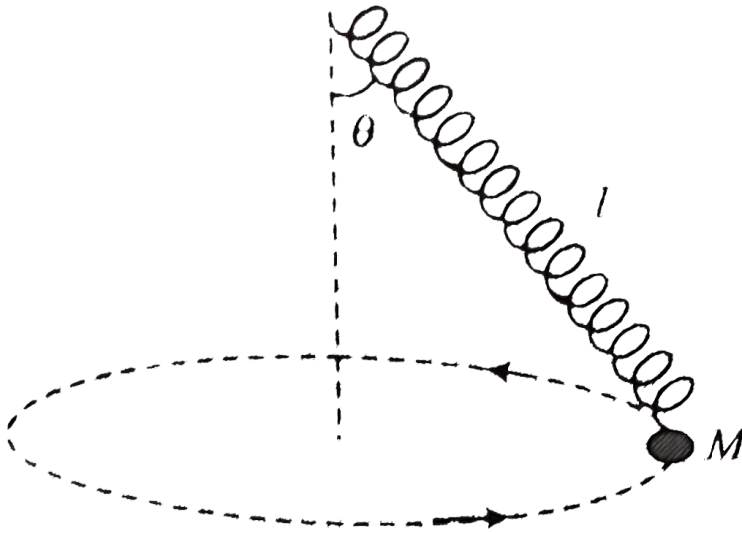

a. In terms of only the given quantities , what is the magnitude of force F that the spring exerts on man M ?

b. In terms of F , k and l what is the natural length l_0 of the spring i.e. the length of the spring when it is not stretched?

c. In terms of F , l , M and B what is the speed v of the ball?



Watch Video Solution

Subjective

1. A block of mass $m = 4\text{kg}$ is placed over a rough inclined plane as shown in fig . The coefficient of friction between the block and the plane $\mu = 0.5$ A force $F = 10\text{N}$ is applied on the block at an angle of 30° . Find the contact force between the block and the plane.

k



Watch Video Solution

2. Block A as shown in figure weight $1.40N$ and block B weight $4.20N$ The coefficient of kinetic friction between all surface is 0.30 Find the magnitude of the horizontal force necessary to drag block B to the left at constant speed if A and B are connected by a light , flexible cord passing around a fixed , frictionless pulley.

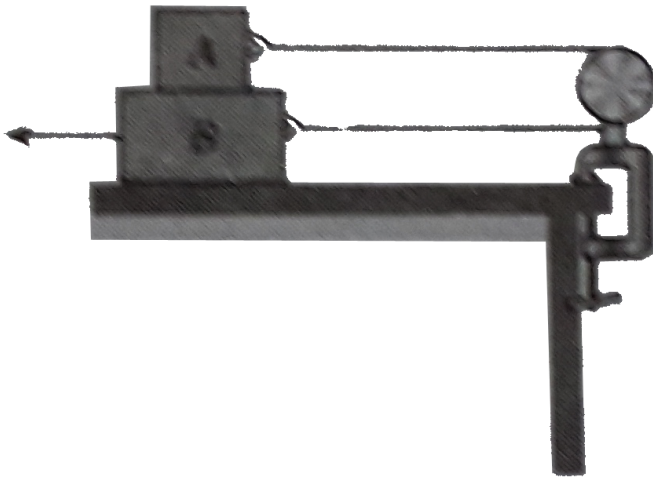

 [Watch Video Solution](#)

3. Two blocks, with masses m_1 and m_2 are stacked as shown in fig and placed on a frictionless horizontal surface. There is a friction between the two blocks. An external force of magnitude F is applied to the top block at an angle α below the horizontal. The coefficient of friction between m_1 and m_2 are μ_s

b. If the two blocks move together, find their acceleration

b. Calculate the maximum value of force so that blocks will move together



[Watch Video Solution](#)

4. Block A has a mass of 30kg and block B has a mass of 15kg . The coefficient of friction between all surface of contact are $\mu_s = 0.15$ and $\mu_k = 0.10$ Knowing that $\theta = 30^\circ$ and that the magnitude of the force F applied to block A is 250N Determine (a) acceleration of block A and (b) the tension in the rope



[Watch Video Solution](#)

5. Block A weight 20kg placed on a smooth surface. Weight B of 2kg is mounted on the block. The coefficient of friction between the block and the weight is 0.25 Calculate the acceleration of the block and the

weight and also the frictional force between the block and the weight when a horizontal force $2N$ applied to the weight as shown in fig What will these quantities be if the horizontal force is $20N$? ($g = 10ms^{-2}$)



[Watch Video Solution](#)

6. In figure find the acceleration of m assuming that there is friction between m and M and all other surfaces are smooth and pulleys light and $\mu =$ coefficient of friction between m and M



[Watch Video Solution](#)

7. The masses of the block A and B are m and M . Between A and B there is a constant force F but B can slide frictionlessly on the horizontal surface. A is set in motion with velocity v_0 while B is at rest. What is the distance moved by A relative to B before they move with the same velocity?

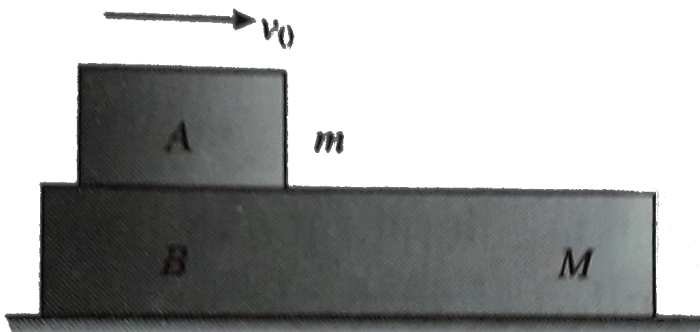

[Watch Video Solution](#)

8. Two block of masses m and M are connected by a chord passing around a frictionless pulley which is attached to a rotating frame , which rotates about a vertical axis with an angular velocity ω If the coefficient of friction between the two masses and the surface are μ_1 and μ_2 respectively determine the value of ω at

which the block starts sliding radially ($M > m$)

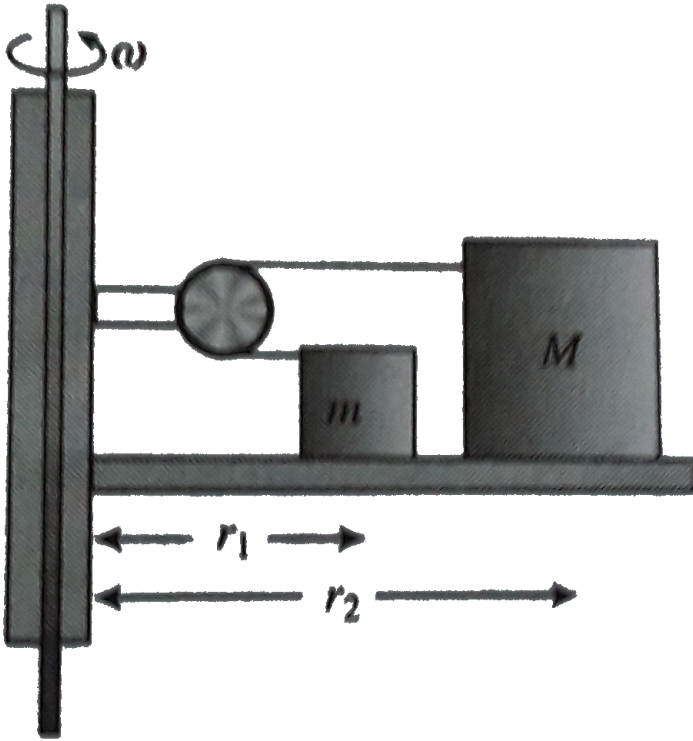

[Watch Video Solution](#)

9. A block with mass m_1 is placed on an inclined plane with slope angle α and is connected to a second

hanging block with mass m_2 by a cord passing over a small frictionless pulley as shown in fig 7.247. The coefficient of static friction is μ_s and the coefficient of kinetic friction is μ_k

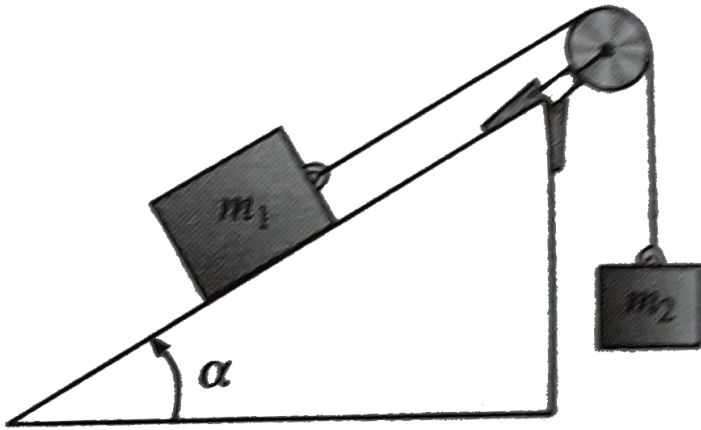

- Find the mass m_2 for which block m_1 moves up plane at constant speed once it is set in motion
- Find the mass m_2 for which block m_1 moves down the plane at constant speed once it is set in motion
- For what range of m_2 will the blocks remain at rest if they are released from rest?



Watch Video Solution

10. Consider three blocks placed one over the other as shown in Fig. Let us now pull the blocks with the force of magnitudes $18N$, $100N$ and $15N$. Take $m_1 = m_2 = m_3 = 10kg$. If the coefficient of static and kinetic friction between all contacting surfaces are $\mu_s = 0.2$ respectively find the

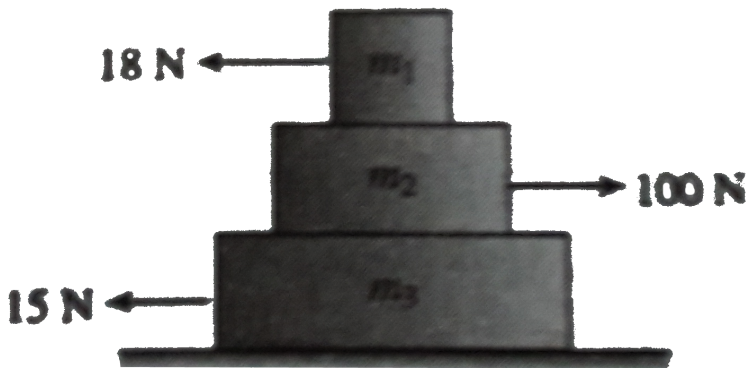

- (a) Acceleration of the blocks
- (b) Friction at each surface



Watch Video Solution

11. Four blocks are arranged on a smooth horizontal surface as shown in figure. The masses of the blocks are given (see the fig). The coefficient of static friction between the top and the bottom blocks is μ_s . What is the maximum value of the horizontal force F applied to one of the bottom blocks as shown that makes all four blocks with the same acceleration?

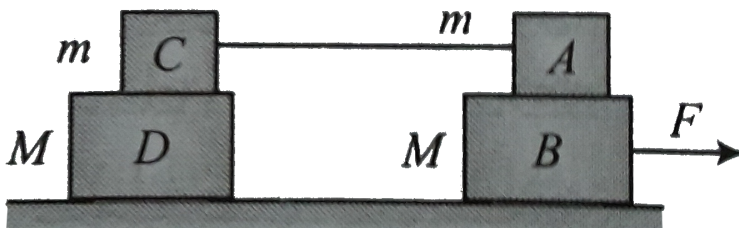

Watch Video Solution

12. A block of mass m is pressed against a wall which is moving with an acceleration a as shown in figure. If the block is pulled at an angle θ with downward vertical by a force F and it does not slide relative to the wall. Find the

a. friction force between the block and wall

b. minimum magnitude of F so as to cause a relative

sliding between the block and wall

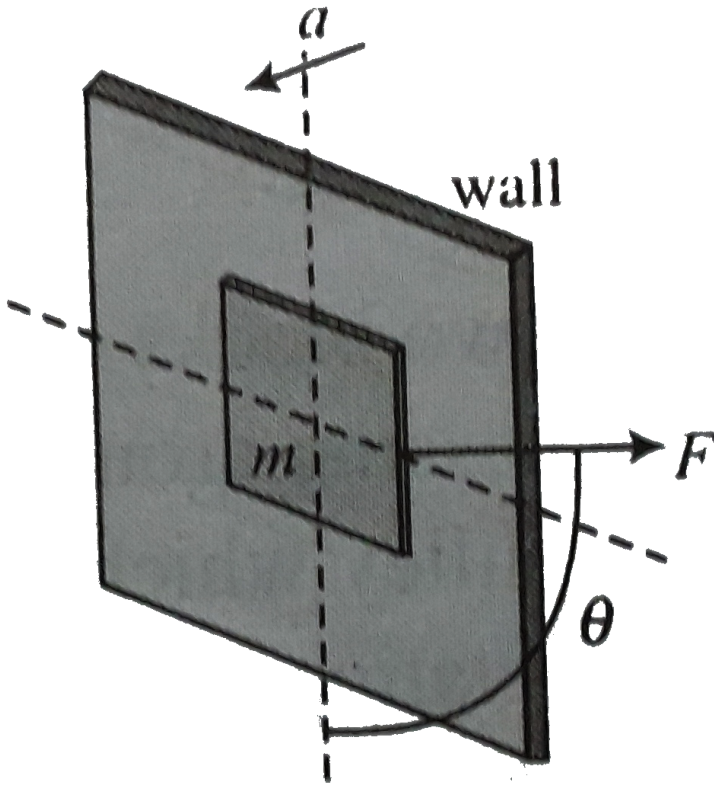

[▶ Watch Video Solution](#)

13. In the arrangement shown in figure pulleys are mass of block A, b and C is $m_1 = 5kg$ $m_2 = 4kg$ and

$m_3 = 2.5\text{kg}$ respectively. Co-efficient of friction of friction for both the plane is $\mu = 0.50$. Calculate acceleration of which block when system is released from rest

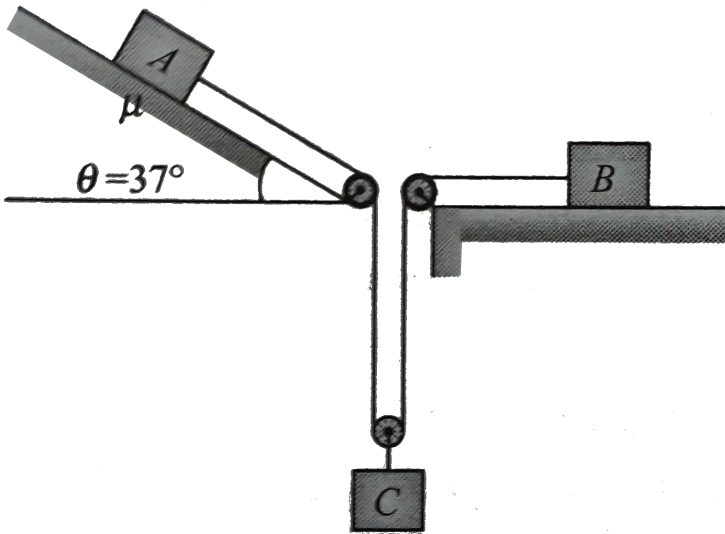

[Watch Video Solution](#)

14. In the arrangement shown in figure mass of blocks A, B and C is 18.5kg , 8kg and 1.5kg respectively. The

bottom surface of A is smooth while coefficient of friction that between block A and C is $\mu_1 = 1/3$ between B and floor is $\mu_2 = 1/5$ System is released from rest $v = 0$ and pulley are light and friction Calculate acceleration of block A, B and C

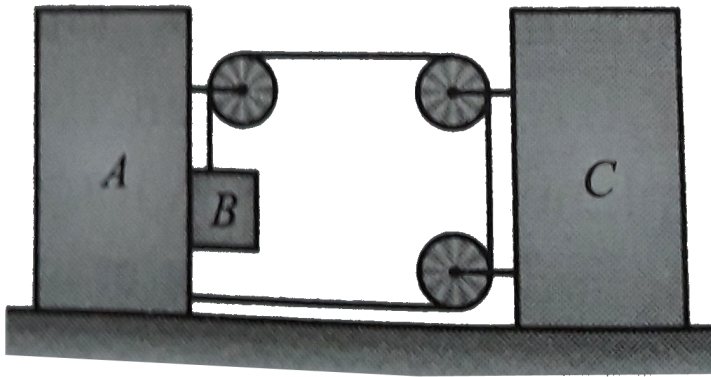

[▶ Watch Video Solution](#)

15. A cubical block is experiencing three forces $F_1 = 20N$ acts at angle 45° with horizontal and lies in

diagram plane of the cube $F_2 = 30N$ acts along y - axis and $F_3 = 40N$ acts in x - direction as shown in fig find the friction force acting on the block if it is at rest

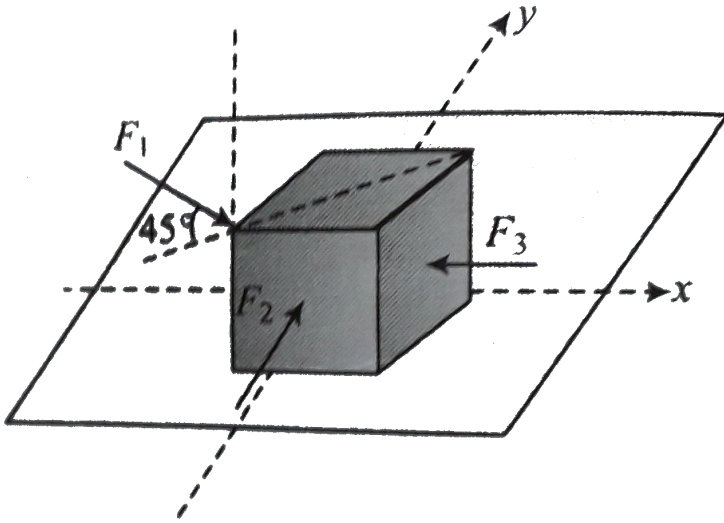

[▶ Watch Video Solution](#)

16. A block of mass $m = 3kg$ is resting over a rough horizontal surface having coefficient of friction $\mu = 1/3$ The block is pulled to the right by applying a

force F inclined at angle 37° with the horizontal as shown in fig .The force increases with time according to law $F = 2t$ newton Calculate its velocity v at $t = 10s$ ($g = 10ms^{-2}$)

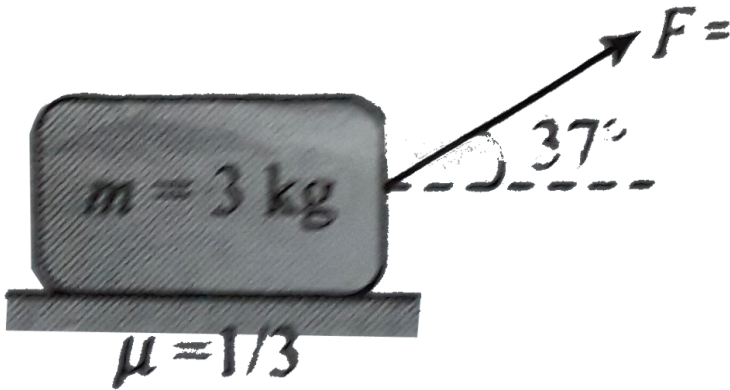

[Watch Video Solution](#)

17. The mass of the wedge shown in fig is $M = 4kg$ and that of block is $m = 1kg$ The horizontal surface beneath the wedge is smooth while the wedge and

block is equal to $\mu = 0.1$. Taking $g = 9.8\text{ms}^{-2}$ and assuming pulley to be massless and frictionless. Calculate maximum possible value of force F upto which the block will remain stationary relative to the wedge.

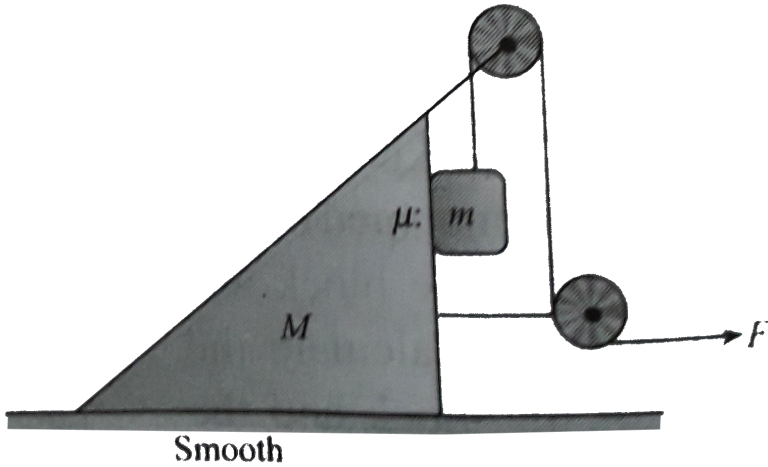

[Watch Video Solution](#)

18. Block B of mass $m_B = 0.5\text{kg}$ rests on block A, with mass $m_A = 1.5\text{kg}$ which in turn is on a horizontal

tabletop (as shown in figure) .The coefficient of kinetic friction between block A and the tabletop is $\mu_k = 0.4$ and the coefficient of static friction between block A and block B is $\mu_s = 0.6$ A light string attached block A passes over a frictionless, massless pulley and block C is suspended from the other end of the string. What is the largest mass m_c (in kg) that block C can have so that block A and B still slide together when the system is released from rest?

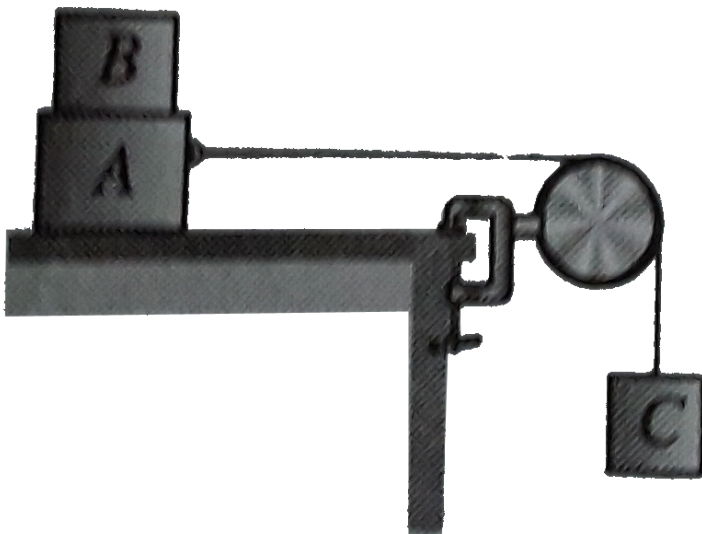



Watch Video Solution

19. With two hands you hold a cone motionless upside down, as shown in figure. The mass of the cone is ($m = 1\text{kg}$) and the coefficient of static friction between your fingers and the cone is ($\mu = 0.5$) what is the minimum normal force you must apply with each hand in order to hold up the cone? Consider only

translational equilibrium

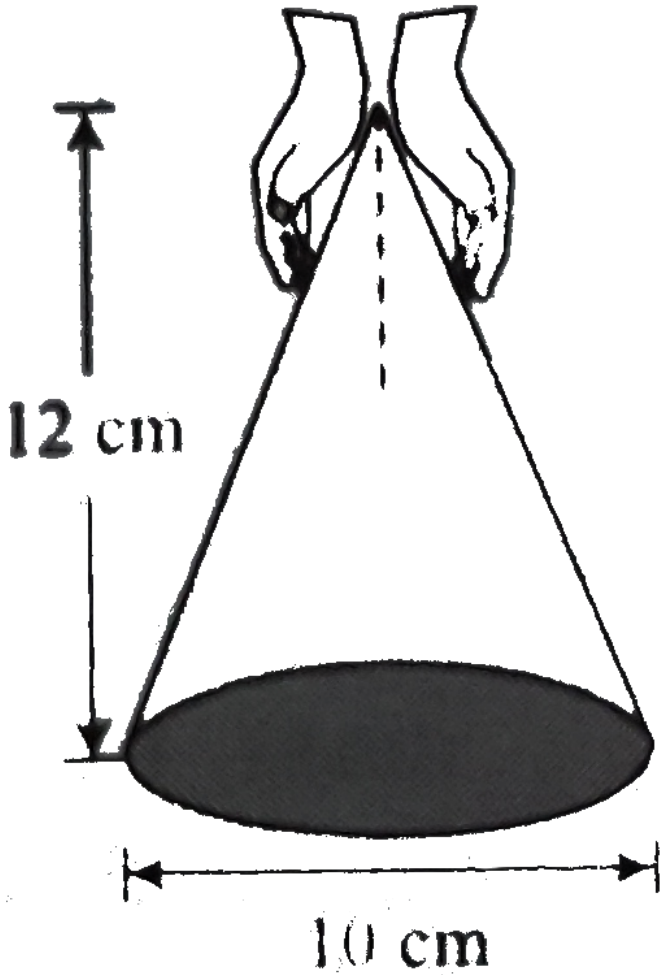

[Watch Video Solution](#)

20. A prismatic block of mass m is kept on a groove . The bottom line of the groove makes an angle θ with horizontal . The angle between the flat surface 1 and 2 making the groove is ϕ If the groove is symmetrical with the normal to the inclined plane containing the bottom line of the groove

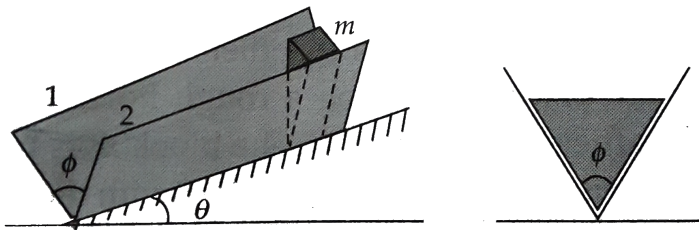

- Find the coefficient of friction μ_0 between the block and groove so that the block begins to slide.
- If $\mu > \mu_0$ find the friction force on the block.
- If $\mu < \mu_0$ find the acceleration of the block.

21. A block of mass m_1 connected with another of mass m_2 by a light spring of natural length l_0 and stiffness k is kept stationary on a rough horizontal surface. The coefficient of friction between m_1 and surface is μ and the block m_2 is smooth. The block m_2 is moved with certain the block m_1 in horizontal plane Find the (a) maximum to m_1 and (b) acceleration of m_2 in part(a)

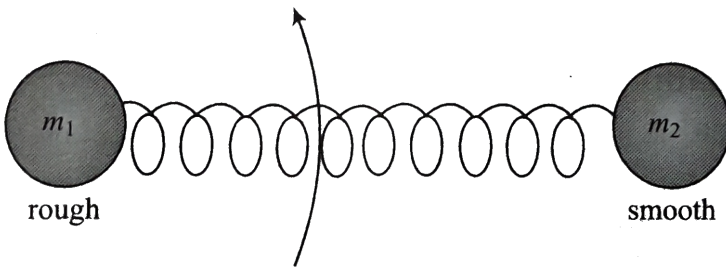

 [Watch Video Solution](#)

Single Correct

1. Two block of masses M_1 and, M_2 are connected with a string which passed over a smooth pulley . The mass M_1 is placed on a tough inclined plane as shown in figure .The coefficient of friction between and block and the inclined plane is μ what should be the minimum mass M_2 so that the block M_1 slides upwards?

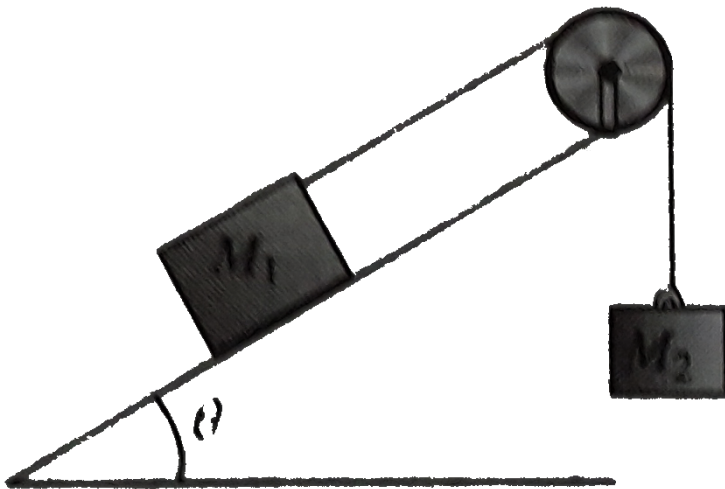

A. $M_2 = M_1(\sin \theta + \mu \cos \theta)$

B. $M_2 = M_1(\sin \theta - \mu \cos \theta)$

C. $M_2 = \frac{M_1}{\sin \theta + \mu \cos \theta}$

D. $M_2 = \frac{M_1}{\sin \theta - \mu \cos \theta}$

Answer: a



Watch Video Solution

2. A box of mass $8kg$ placed on a rough inclined plane of inclination θ its downward motion can be prevented by applying an upward pull F and it can be made to slide upward applying a force $2F$. The coefficient of friction between the box and the inclined plane is

A. $(\tan \theta) / 3$

B. $3 \tan \theta$

C. $(\tan \theta) / 2$

D. $2 \tan \theta$

Answer: a



Watch Video Solution

3. A block of mass 15kg is resting on a rough inclined plane as shown in figure ,The block is tied by a horizontal string which has a tension 50N The

coefficient of contact is

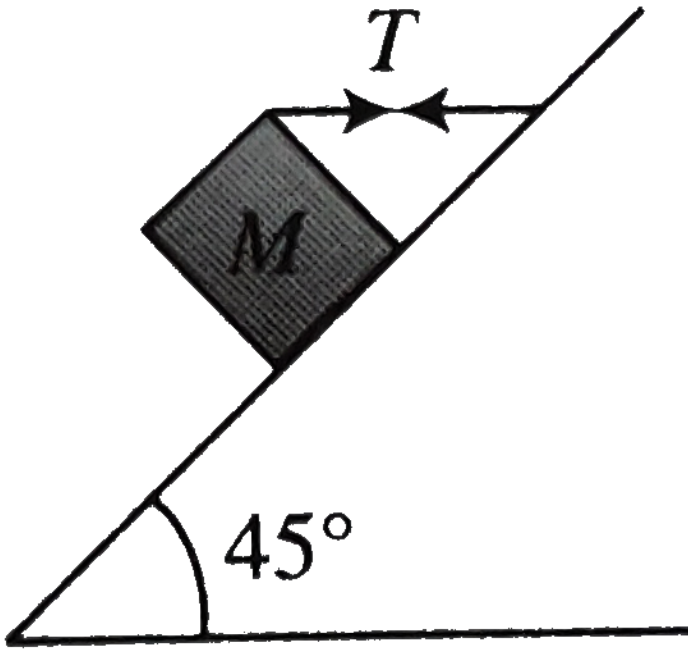

A. $1/2$

B. $2/3$

C. $3/4$

D. $1/4$

Answer: a



Watch Video Solution

4. A horizontal force just sufficient to move a body of mass $4kg$ lying on a rough horizontal surface is applied on it .The coefficient of static and kinetic friction the body and the surface are 0.8 and 0.6 respectively If the force continues to act even after the block has started moving the acceleration of the block in ms^{-2} is ($g = 10ms^{-2}$)

A. $1/4$

B. $1/2$

C. 2

D. 4

Answer: c



Watch Video Solution

5. Blocks A and B in the Fig are connected by a bar of negligible weight .Mass of each block is $170kg$ and $\mu_A = 0.2$ and $\mu_B = 0.4$ where μ_A and μ_B are the coefficient of limiting friction between block and plane

calculate the force developed in the bar ($g = 10\text{m/s}^{-2}$)

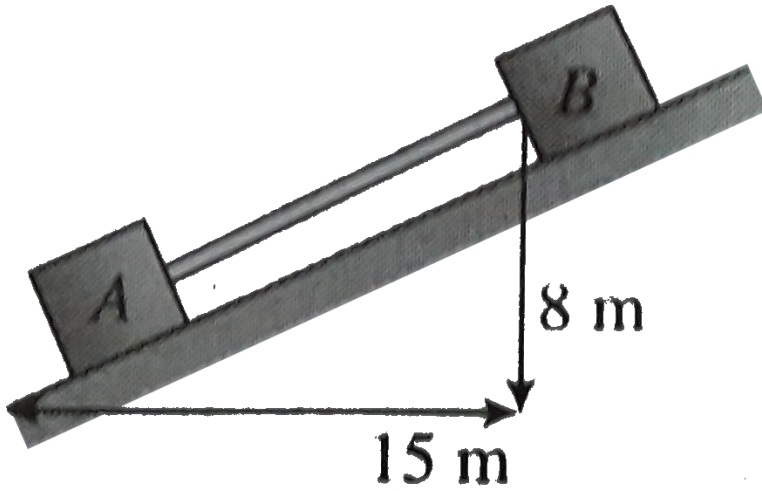

A. 150N

B. 75N

C. 200N

D. 250N

Answer: a



Watch Video Solution

6. The upper half of an inclined plane of inclination θ is perfectly smooth while lower half is rough. A block starting from rest at the top of the plane will again come to rest at the bottom, if the coefficient of friction between the block and lower half of the plane is given by

A. $2 \tan \phi$

B. $\tan \phi$

C. $2 \sin \phi$

D. $2 \cos \phi$

Answer: a

7. A block of mass m is placed on another block of mass M which itself is lying on a horizontal surface. The coefficient of friction between two blocks is μ_1 and that between the block of mass M and horizontal surface is μ_2 . What maximum horizontal force can be applied to the lower block move without separation?

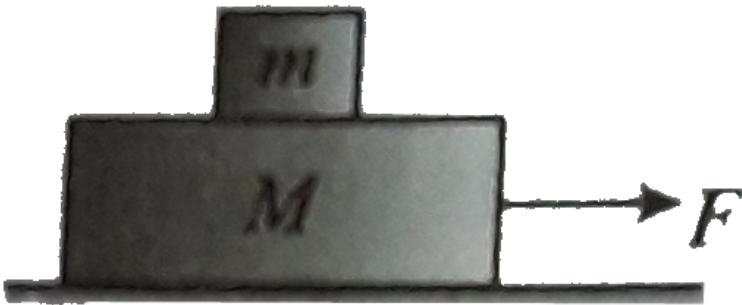

A. $(M + m)(\mu_2 - \mu_1)g$

B. $(M - m)(\mu_2 - \mu_1)g$

C. $(M - m)(\mu_2 + \mu_1)g$

D. $(M + m)(\mu_2 + \mu_1)g$

Answer: d



Watch Video Solution

8. Two block A and B of masses $6kg$ and $3kg$ rest on a smooth horizontal surface as shown in figure If coefficient of friction between A and Bb is 0.4 the maximum horizontal force which can make them move

without separation is

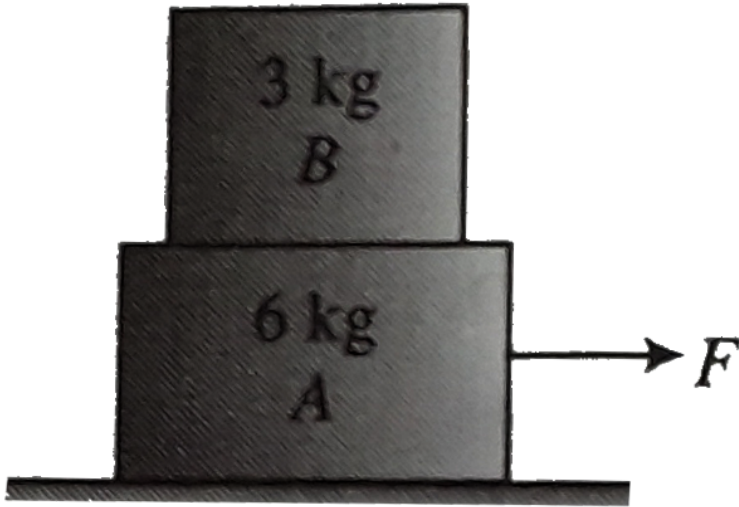

A. $72N$

B. $40N$

C. $36N$

D. $20N$

Answer: c



Watch Video Solution

9. Two blocks of masses M_1 and M_2 are connected with a string passing over a pulley as shown in figure. The block M_1 lies on a horizontal surface. Friction between the block M_1 and the horizontal surface is μ . The system accelerates. What additional mass m should be placed on the block M_1 so that the system does not

accelerate ?

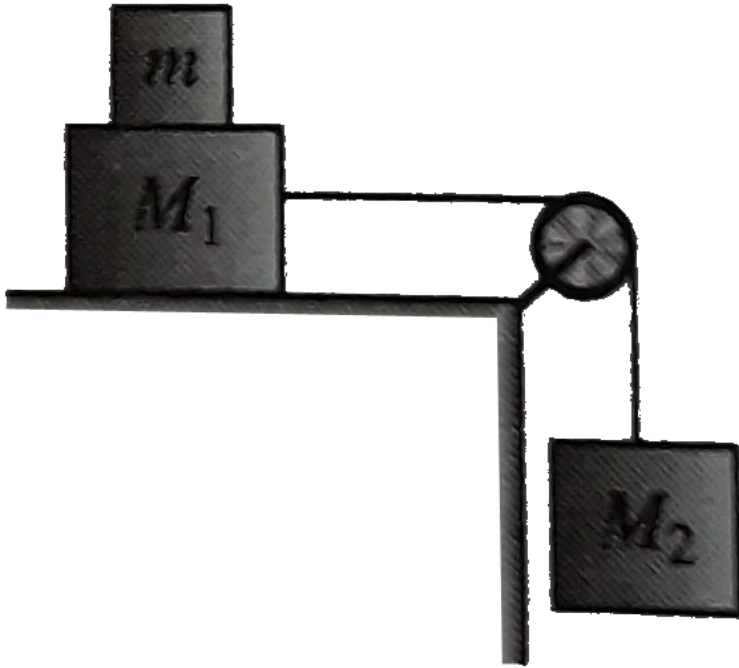

A. $\frac{M_2 - M_1}{\mu}$

B. $\frac{M_2}{\mu} - M_1$

C. $M_2 - \frac{M_1}{\mu}$

D. $(M_2 - M_1)\mu$

Answer: b



Watch Video Solution

10. A system is pushed by a force F as shown in figure
All surfaces are smooth except between B and C is μ .
Minimum value fo F to prevent block B from down
ward slipping is

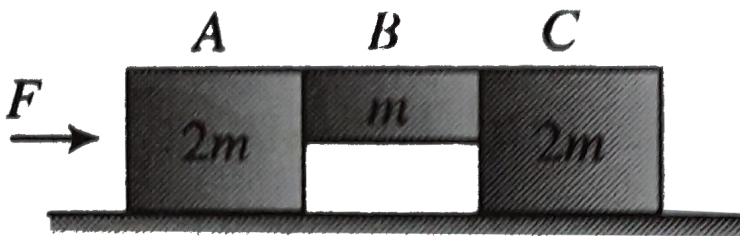

A. $\left(\frac{3}{2\mu}\right)mg$

B. $\left(\frac{5}{2\mu}\right)mg$

C. $\left(\frac{5}{2}\right)\mu mg$

D. $\left(\frac{3}{2}\right)\mu mg$

Answer: B



Watch Video Solution

11. A body of mass M is resting on a rough horizontal plane surface the coefficient of friction being equal to μ . At $t = 0$ a horizontal force $F = F_0 t$ starts acting on it, where F_0 is a constant find the time T at which the motion starts?

A. $\mu Mg / F_0$

B. $mg / \mu F_0$

C. $\mu F_0 Mg$

D. None of these

Answer: a



Watch Video Solution

12. The maximum value of mass of block C so that neither A nor B moves is (given that mass of A is $100kg$ and the of B $140kg$. Pulleys are smooth and friction coefficient between A and B and horizontal surface

$\mu = 0.3$) (Taking $g = 10 \text{ m s}^{-2}$)

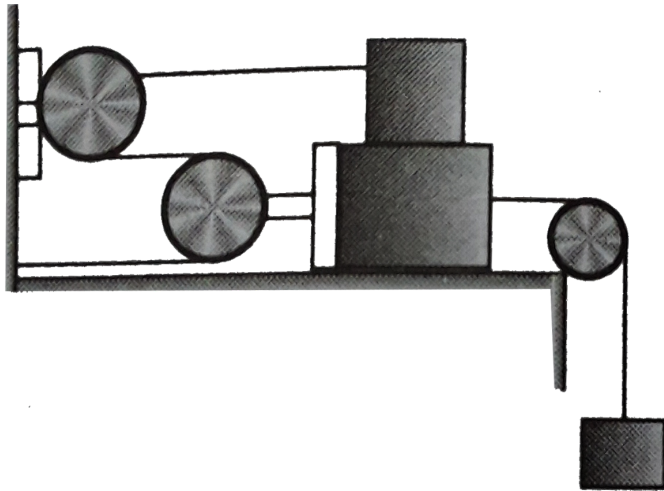

A. 210 kg

B. 190 kg

C. 185 kg

D. 162 kg

Answer: d



Watch Video Solution

13. A block A of mass 2kg is placed over smooth block B of mass 4kg which is placed over a smooth horizontal floor. The coefficient of friction between A and B is 0.4 when a horizontal force of magnitude 10N is applied on A the acceleration of block of A and B are

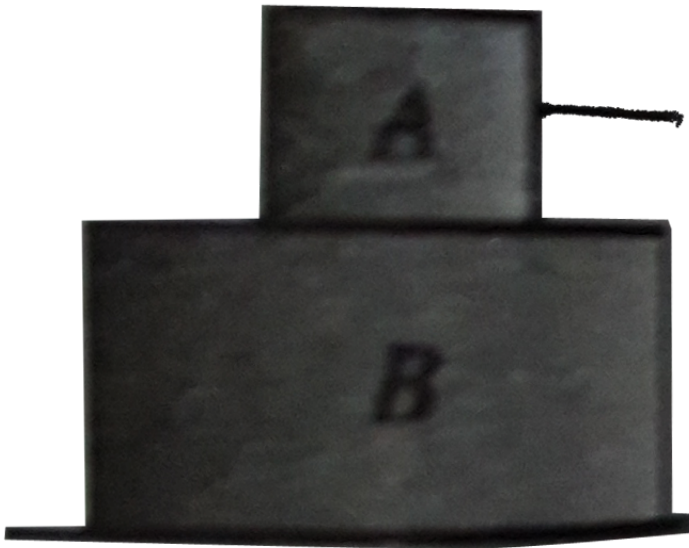

A. 1ms^{-2} and 2ms^{-2} , respectively

B. $5ms^{-2}$ and $2.5ms^{-2}$, respectively

C. Both the block will moves together with
acceleration $1/3ms^{-2}$

D. Both the block will moves together with
acceleration $5/3ms^{-2}$

Answer: d



Watch Video Solution

14. Two block m and M tied together with an inextensible string are placed at rest on a rough horizontal surface with coefficient of friction μ The block m is pulled with a variable force F at a varying

angle θ with the horizontal. The value of θ at which the least value of F is required to move the blocks given by

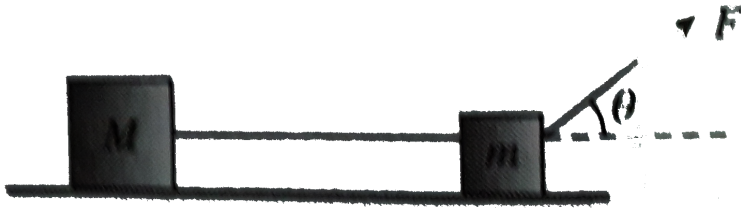

Rough surface (μ)

A. $\theta = \tan^{-1} \mu$

B. $\theta > \tan^{-1} \mu$

C. $\theta < \tan^{-1} \mu$

D. Insufficient data

Answer: a



Watch Video Solution

15. A trolley has a simple pendulum suspended from a frame fixed to its desk. A block B is in contact on its vertical end. The trolley is on horizontal rails and has an acceleration toward the right such that the block is just prevented from falling. The value of coefficient of

friction between A and B is 0.5 to the vertical is

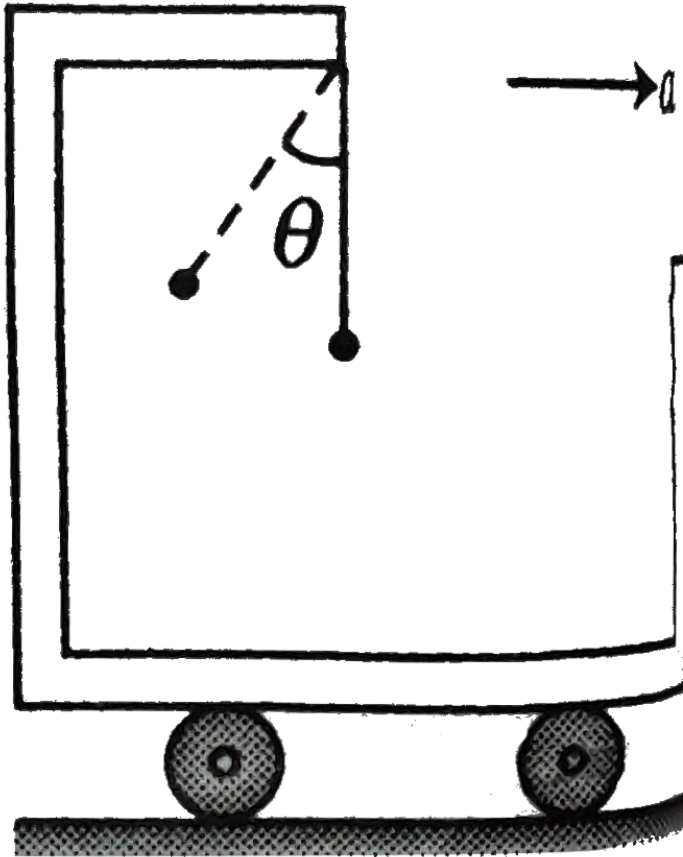

A. $\tan^{-1}\left(\frac{1}{2}\right)$

B. $\tan^{-1}(3)$

C. $\tan^{-1}(\sqrt{2})$

D. $\tan^{-1}(2)$

Answer: D



Watch Video Solution

16. Two blocks M and m are arranged as shown in the diagram. The coefficient of friction between the block is $\mu_1 = 0.25$ and between the ground and M is $\mu_2 = \frac{1}{3}$. If $M = 8\text{kg}$ then find the value of m so that the system

will remain at rest

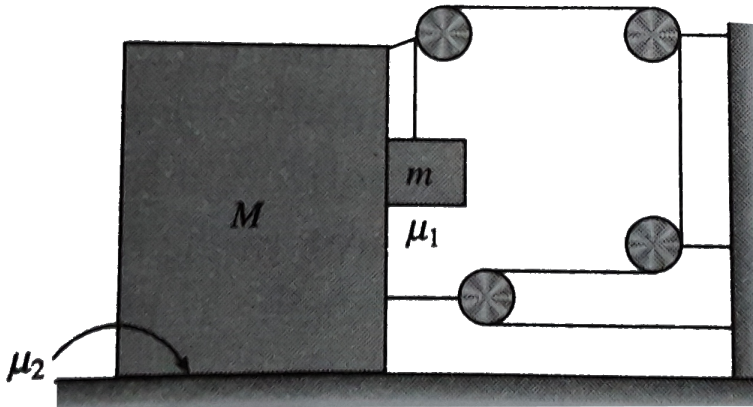

A. $4/3kg$

B. $8/9kg$

C. $1kg$

D. $8/5kg$

Answer: c



Watch Video Solution

17. A body of mass m is launched up on a rough inclined plane making an angle 45° with horizontal. If the time of ascent is half of the time of descent, the frictional coefficient between plane and body is

A. $\frac{2}{5}$

B. $\frac{3}{5}$

C. $\frac{3}{4}$

D. $\frac{4}{5}$

Answer: b



Watch Video Solution

18. A block of mass m is placed at rest on a horizontal rough surface with angle of friction ϕ . The block is pulled with a force F at an angle θ with the horizontal. The minimum value of F required to move the block is

A. $\frac{F}{M}(\cos \phi - \sin \phi) - \mu g$

B. $\frac{\mu F}{M} \cos \phi$

C. $\frac{F}{M}(\cos \phi + \sin \phi) - \mu g$

D. $\frac{F}{M} \sin \phi$

Answer: c



Watch Video Solution

19. The time taken by a body to slide down a rough 45° inclined plane is twice that required to slide down a smooth 45° inclined plane. The coefficient of kinetic friction between the object and rough plane is given by

A. $\sqrt{\frac{1}{1 - n^2}}$

B. $\sqrt{1 - \frac{1}{n^2}}$

C. $1 - \frac{1}{n^2}$

D. $\frac{1}{2 - n^2}$

Answer: c



Watch Video Solution

20. A passenger is traveling a train moving at 40ms^{-1} . A suitcase is kept on the berth. The driver of the train applies brakes such that the speed of the train decreases at a constant rate to 20ms^{-1} in 5s . What should be the minimum coefficient of friction between the suitcase and the berth if the suitcase is not to slide during retardation of the train?

A. 0.3

B. 0.5

C. 0.1

D. 0.2

Answer: b



Watch Video Solution

21. In figure the tension in the rope (rope is light) is

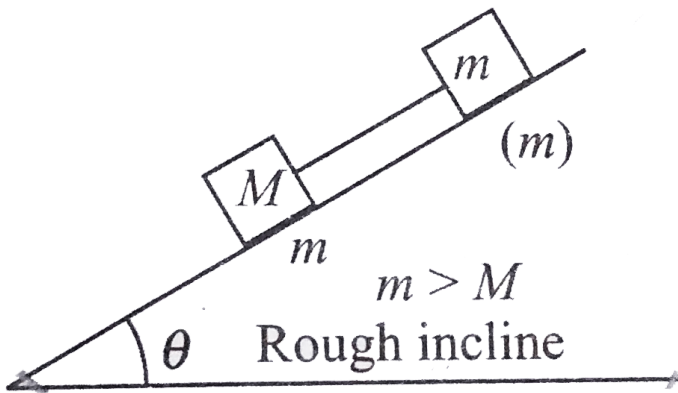

- A. $(M + m)g \sin \theta$
- B. $(M + m)g \sin \theta - \mu mg \cos \theta$
- C. Zero
- D. $(M + m)g \sin \theta$

Answer: c



Watch Video Solution

22. An inclined plane is moving up with constant velocity v . A block kept on incline is at rest. Calculate the work done by gravity, friction force, and normal

reaction on block in time interval of t .

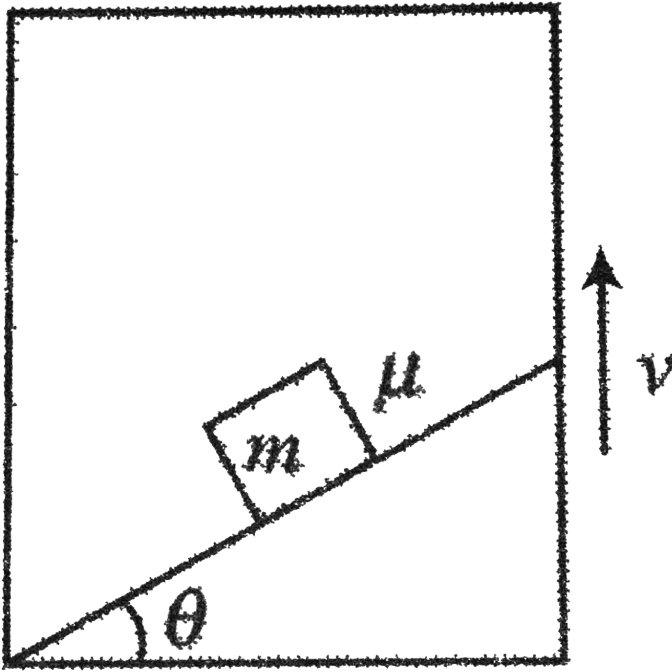

- A. The contact force between block and inclined is parallel to the incline
- B. The contact force between block and inclined is of the magnitude $m(g + a)$

C. The contact force between block and inclined is perpendicular to the incline

D. The contact force is of the magnitude $mg \cos \theta$

Answer: b



Watch Video Solution

23. A block of mass m lying on a rough horizontal plane is acted upon by a horizontal force P and another force Q inclined at an angle θ to the vertical. The minimum value of coefficient of friction of friction between the block and the surface for which the block will remain in

equilibrium is

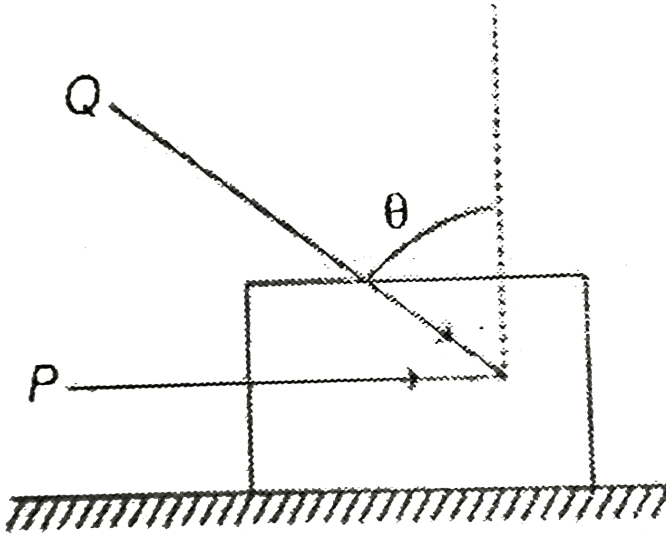

- A. $(P \sin \theta - Q) / (mg - \cos \theta)$
- B. $(P - Q \sin \theta) / (mg + \cos \theta)$
- C. $(P \cos \theta + Q) / (mg - \cos \theta)$
- D. $(P + Q \sin \theta) / (mg + Q \cos \theta)$

Answer: b





24. A horizontal force of 25 N is necessary to just hold a block stationary against between the block and the wall is 0.4 The weight of the block is

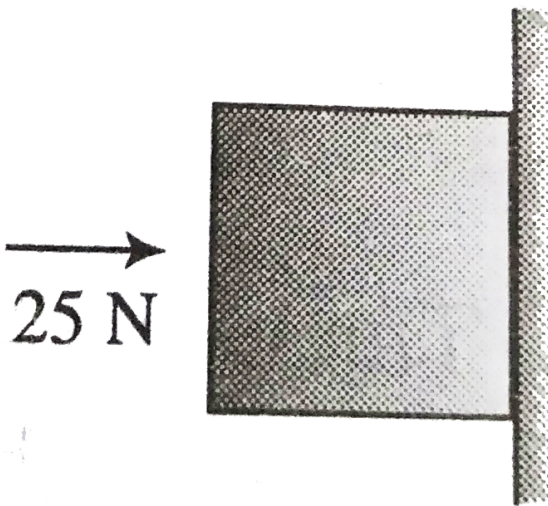

A. 2.5 N

B. 20 N

C. $10N$

D. $5N$

Answer: c



Watch Video Solution

25. A solid block of mass $2kg$ is resting inside a cube shown in figure The cube is moving with a velocity $\hat{v} = 5\hat{i} + 2\hat{j}ms^{-1}$ If the coefficient of friction between the surface of cube and block is 0.2 then the force of friction between the block and cube is



A. $10N$

B. $4N$

C. $14N$

D. Zero

Answer: d



Watch Video Solution

26. A block of mass m is lying on a wedge having inclination angle $\alpha = \tan^{-1}\left(\frac{1}{5}\right)$ wedge is moving with a constant acceleration $a = 2ms^{-2}$ The minimum value of coefficient of friction μ so that m remain

stationary w.r.t. wedge is

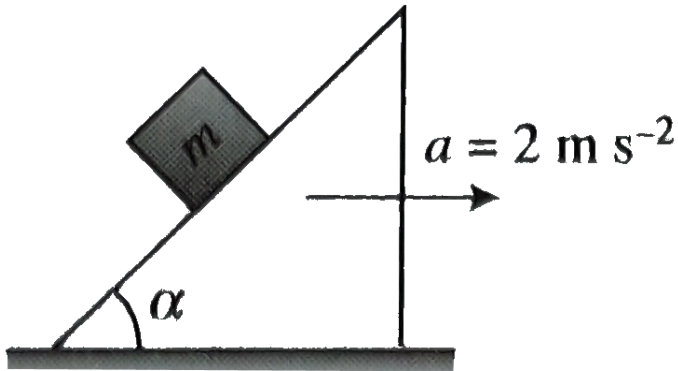

A. $2/9$

B. $5/12$

C. $1/5$

D. $2/5$

Answer: b



Watch Video Solution

27. In Fig the block are at rest a force of $10N$ act on the block of $4kg$ mass .The coefficient of staic friction and the coefficient of kinetic friction are $\mu_s = 0.2$ and $\mu_s = 0.15$ for both the surface in contact The magnitude of frcition force acting between the surface of contact between the $2kg$ and $4kg$ block in this situation is

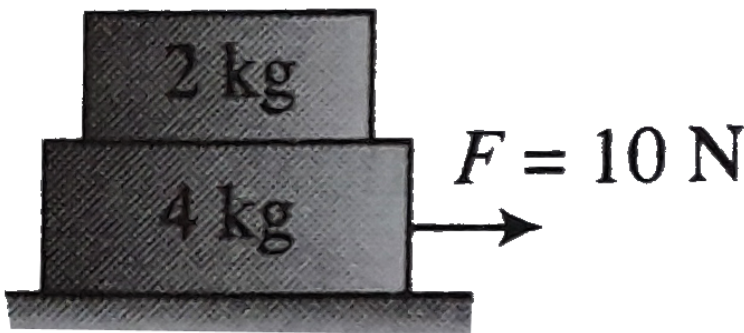

A. $3N$

B. $4N$

C. $3.33N$

D. Zero

Answer: d



Watch Video Solution

28. The masses of the block A and B are m and M . Between A and B there is a constant force F but B can slide frictionlessly on the horizontal surface. A is set in motion with velocity v_0 while B is at rest. What is the distance moved by A relative to B before they move

with the same velocity

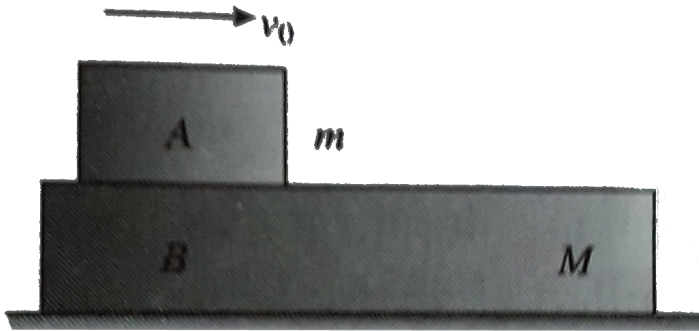

- A. $\frac{mMv_0^2}{F(m - M)}$
- B. $\frac{mMv_0^2}{2F(m - M)}$
- C. $\frac{mMv_0^2}{F(m + M)}$
- D. $\frac{mMv_0^2}{2F(m + M)}$

Answer: d



Watch Video Solution

29. Three blocks A, B, and C of equal mass m are placed one over the other on a frictionless surface (table) as shown in figure. The coefficient of friction between any blocks A, B, and C is μ . The maximum value of mass of block D so that the blocks A, B, and C move without slipping over each other is

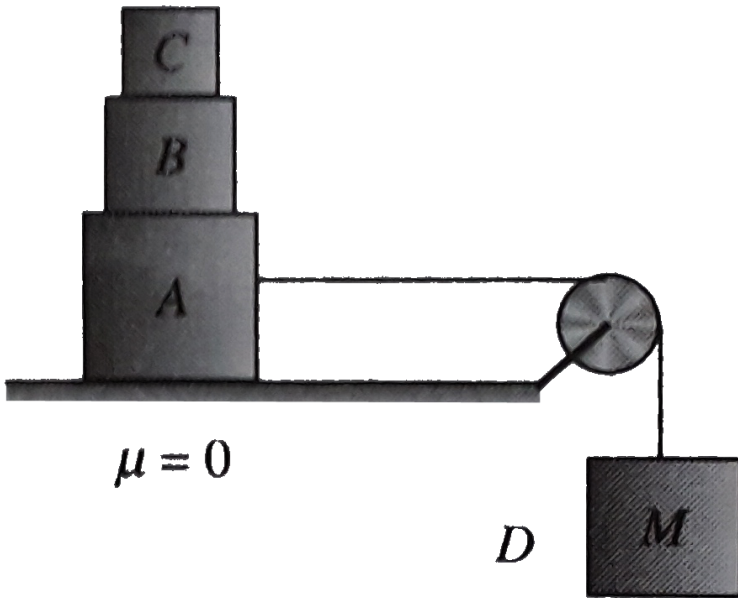

A. $\frac{3m\mu}{\mu + 1}$

B. $\frac{3m(1 - \mu)}{\mu}$

C. $\frac{3m(1 + \mu)}{\mu}$

D. $\frac{3m\mu}{(1 - \mu)}$

Answer: d



Watch Video Solution

30. Two blocks of masses of $0.2kg$ and $0.5kg$ which are placed $22m$ apart on a horizontal surface ($\mu = 0.5$) are acted upon by two forces of magnitude $3N$ each as shown in figure in time $t = 0$ Then the time t at which

they collide with each other is

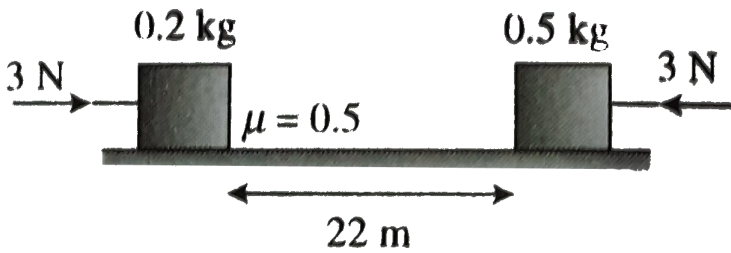

A. $1s$

B. $\sqrt{2}s$

C. $2s$

D. None

Answer: C



Watch Video Solution

31. A chain of length L is placed on a horizontal surface as shown in figure. At any instant x is the length of chain on rough surface and the remaining portion lies on smooth surface. Initially $x = 0$. A horizontal force P is applied to the chain (as shown in figure) in the duration from $x = 0 \rightarrow x = L$. For chain to move with constant speed

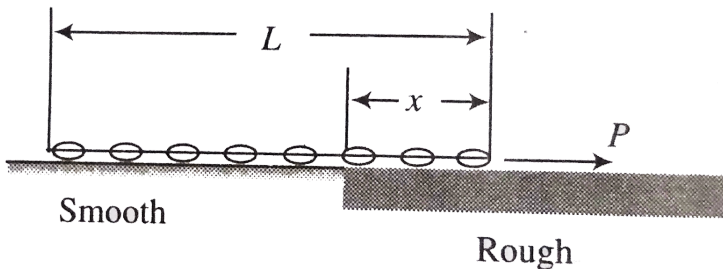

- A. The magnitude of P should increase with time
- B. The magnitude of P should decrease with time

C. The magnitude of P should increase first and then decrease with time

D. The magnitude of P should decrease first and then increase with time

Answer: a



Watch Video Solution

32. A vehicle is moving with a velocity v on a curved road of width b and radius of curvature R . For counteracting the centrifugal force on the vehicle, the difference in elevation required between the

outer and inner edges of the rod is

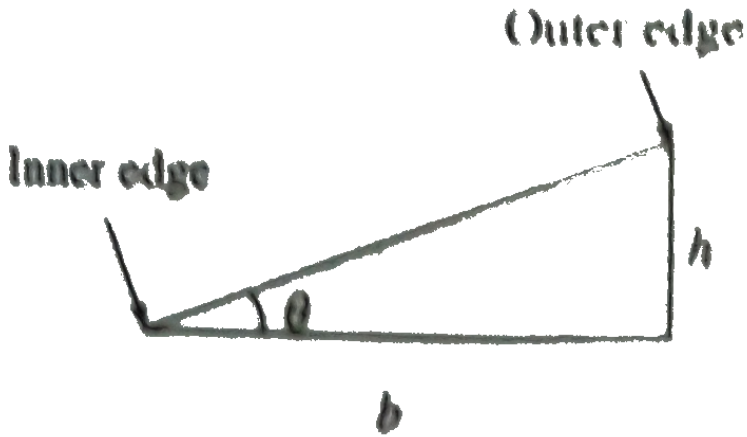

A. $v^3 b / Rg$

B. vb / Rg

C. vb^2 / Rg

D. $vb / R'g$

Answer: a



Watch Video Solution

33. A circular road of radius $1000m$ has hanging angle 45° . The maximum safe speed (in ms^{-1}) of a car having a mass $2000kg$ will be (if the coefficient of friction between tyre and road is 0.3)

A. 172

B. 124

C. 99

D. 86

Answer: A



Watch Video Solution

34. A circular table of radius $0.5m$ has a smooth diametrical groove. A half of mass $90g$ is placed inside the groove along with a spring constant $10^2 Ncm^{-1}$. One end of the spring is tied to the table and the other end to the ball. The ball is at a distance of $.0.1m$ from the center when the table is at rest. On rotating the table with a constant angular frequency of $10^2 \frac{rad}{s^{-1}}$ the ball moves away from the center by a distance nearly equal to

A. $10^{-1}m$

B. $10^{-2}m$

C. $10^{-3}m$

D. $2 \times 10^{-1}m$

Answer: b



Watch Video Solution

35. A disc of radius R rotates from rest about a vertical axis with a constant angular acceleration such that a coin placed with a tangential between a as shown in figure If the coefficient of static friction between the coin and disc is μ_s . Find the velocity of the before it

start sliding relative as the disc

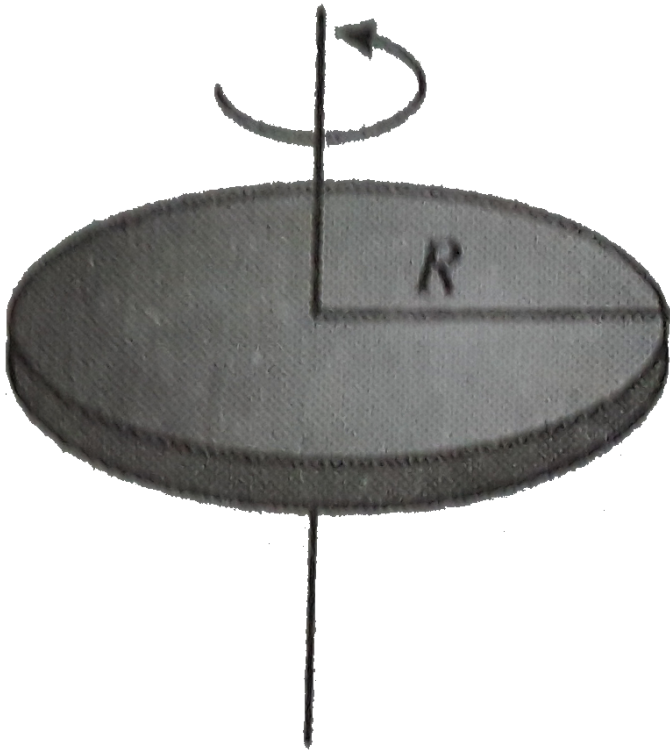

A. 0.1

B. 0.2

C. 0.3

D. 0.4

Answer: b



Watch Video Solution

36. A house is built on the top of a hill with 45° slope. Due to the sliding of material and sand top from top to the bottom of hill, the slip angle has been reduced if the coefficient of static friction between sand particles is 0.75. What is the final angle attained by hill?

$$(\tan^{-1} 0.75 = 37^\circ)$$

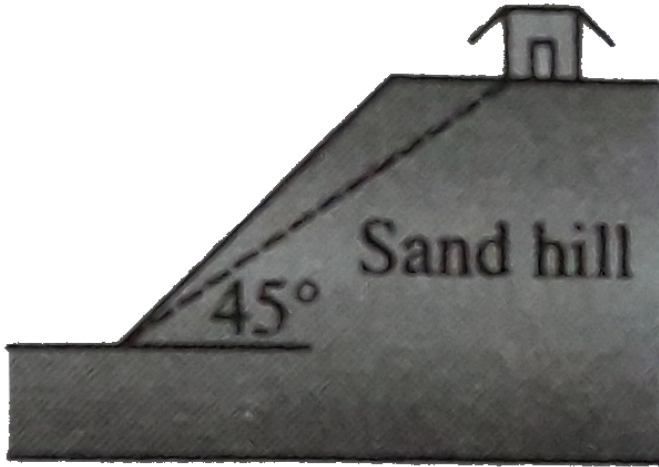

- A. 8°
- B. 45°
- C. 37°
- D. 30°

Answer: c



Watch Video Solution

37. A block of mass 4 kg is pressed against the wall by a force of 80 N as shown in figure Determine the value of the friction force and block's acceleration (Take $\mu_s = 0.2, \mu_k = 0.15$)

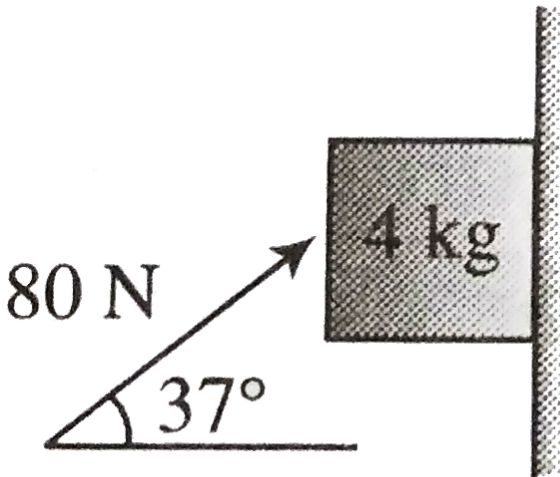

A. $8\text{ N}, 0\text{ m s}^{-2}$

B. $32\text{ N}, 6\text{ m s}^{-2}$

C. $8N, 6ms^{-2}$

D. $32N, 2ms^{-2}$

Answer: a



Watch Video Solution

38. For the situation shown in Fig the block is stationary w.r.t.inclined fixed in an elevator the alevator is having an acceleration of $\sqrt{5}a_0$ whose components are shown in the figure the surface is rough and coefficient of static friction between the inclined and block is μ
Determine the magnitude of force exerted by inclined

on the block (Take $a_0 = g/2$ and $\theta = 37^\circ$, $\mu_s = 0.2$)

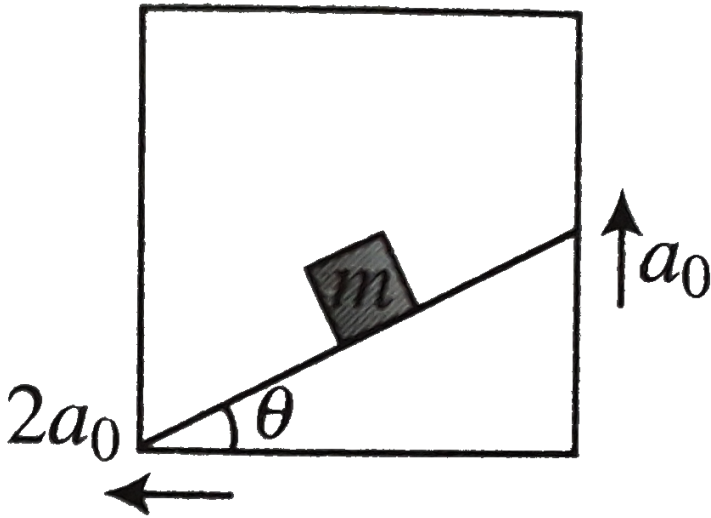

- A. $\frac{mg}{10}$
- B. $\frac{9mg}{25}$
- C. $\frac{3mg}{25} \times \sqrt{41}$
- D. $\frac{\sqrt{13}mg}{2}$

Answer: d



39. If the coefficient of friction between all surface figure is 0.4 then find the minimum force F to have equilibrium of the system.

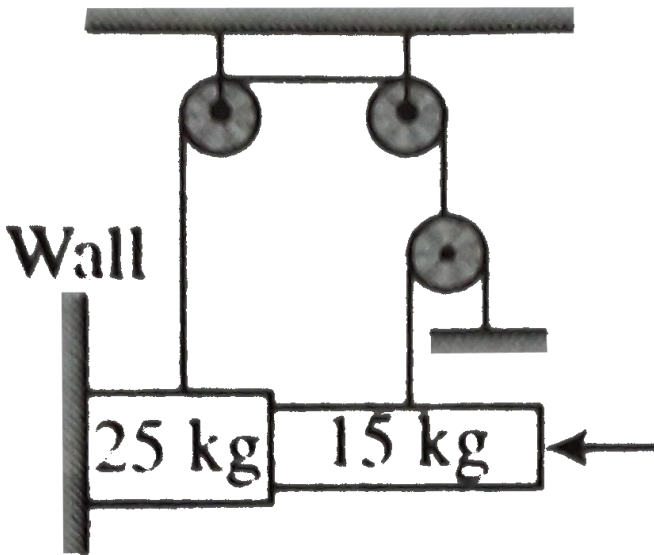

- A. $62.5N$
- B. $150N$

C. $31.25N$

D. $50N$

Answer: c



Watch Video Solution

40. Find the least horizontal force P to start motion of any part of the system of the three blocks resting upon one another as shown in figure. The weights of blocks are $A = 300N$, $B = 100N$ and $C = 200N$. Between A and B , the coefficient of friction is 0.3 between B and C

is 0.2 and between C and the ground is 0.1

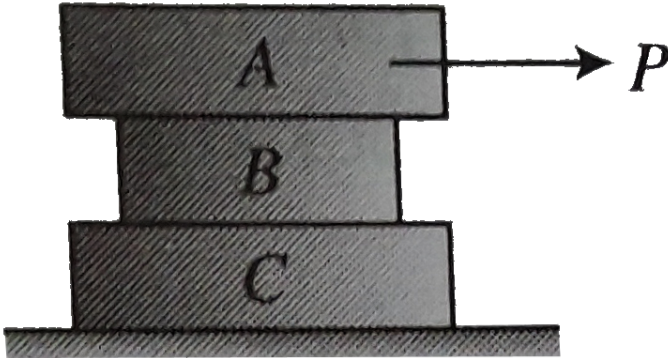

A. $60N$

B. $90N$

C. $80N$

D. $70N$

Answer: a



Watch Video Solution

41. A block of mass m is attached with a massless spring of force constant k . The block is placed over a rough inclined surface for which the coefficient of friction is $\mu = \frac{3}{4}$. The minimum value of M required to move the block up the plane is (Neglect mass of string, mass of pulley and friction in pulley)

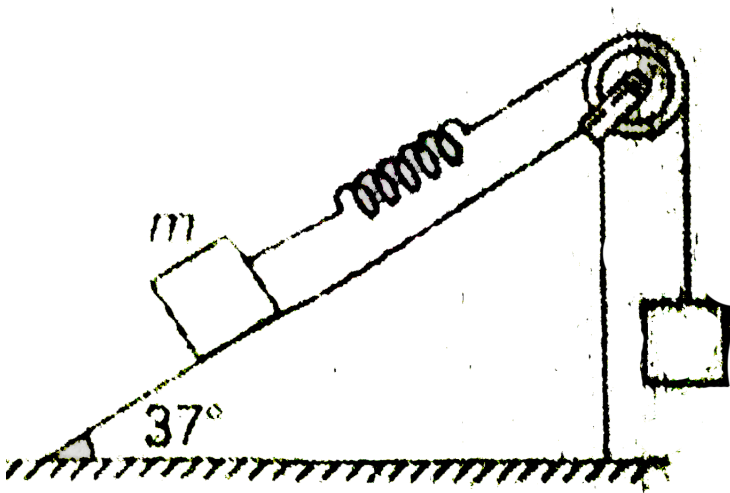

A. $m/2$

B. $m/3$

C. $m/4$

D. None of these

Answer: a



Watch Video Solution

42. In the system shown in Fig the friction coefficient between ground and bigger block is μ . There is no friction between both the blocks. The string connecting both the blocks is light, all three pulleys are light and frictionless. Then the minimum limiting value of μ so

that the system remain in equilibrium , is

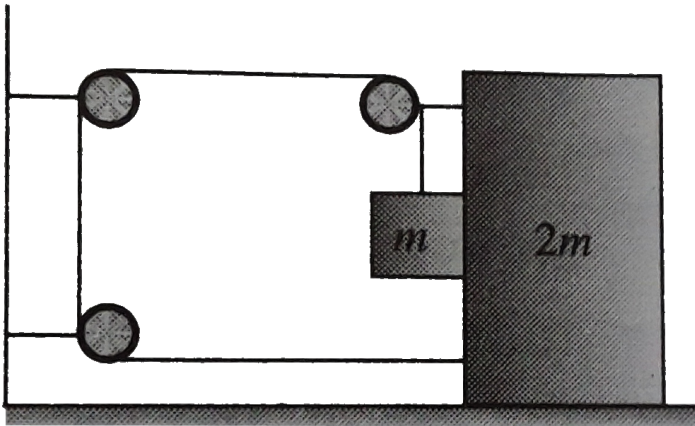

A. $\frac{1}{2}$

B. $\frac{1}{3}$

C. $\frac{2}{3}$

D. $\frac{3}{2}$

Answer: c

 Watch Video Solution

43. Two block A of 6kg and B of 4kg are placed in contact with each other as shown in figure

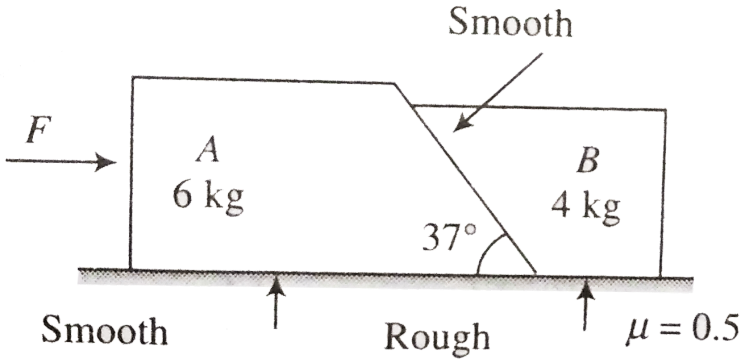

There is no friction A and ground and between both the blocks .The coefficient of friction between B and ground is 0.5 A horizontal force F is applied on A find the minimum and maximum value of F which can be applied so that both blocks can move combinely without any relative between them.

A. 10N , 50N

B. $12N, 50N$

C. $12N, 75N$

D. None of these

Answer: c



Watch Video Solution

44. Two blocks of masses $3kg$ and $2kg$ are placed side by side on an inclined as shown in figure A force $F = 292A$ force $F = 20N$ is active on $2kg$ block along the inclined .The coefficient of friction between the block and the inclined is same and equal to 0.1 .Find

the normal force exerted by 2kg block on 3kg block

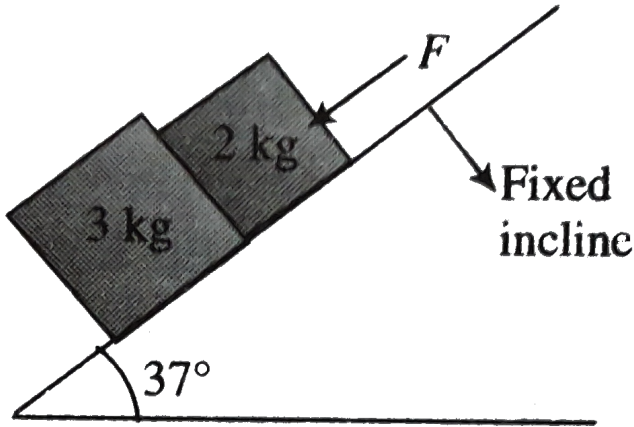

- A. 18N
- B. 30N
- C. 12N
- D. 27.6N

Answer: c



Watch Video Solution

45. Determine the time in which the smaller block reaches other end of bigger block in figure

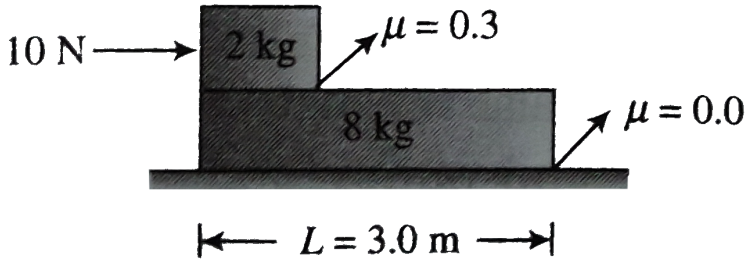

- A. $4s$
- B. $8s$
- C. $2.19s$
- D. $2.13s$

Answer: c



Watch Video Solution

46. A uniform chain is placed at rest on a rough surface of base length l and height h on an irregular surface as shown in figure. Then the minimum coefficient of friction between the chain and the surface must be equal to

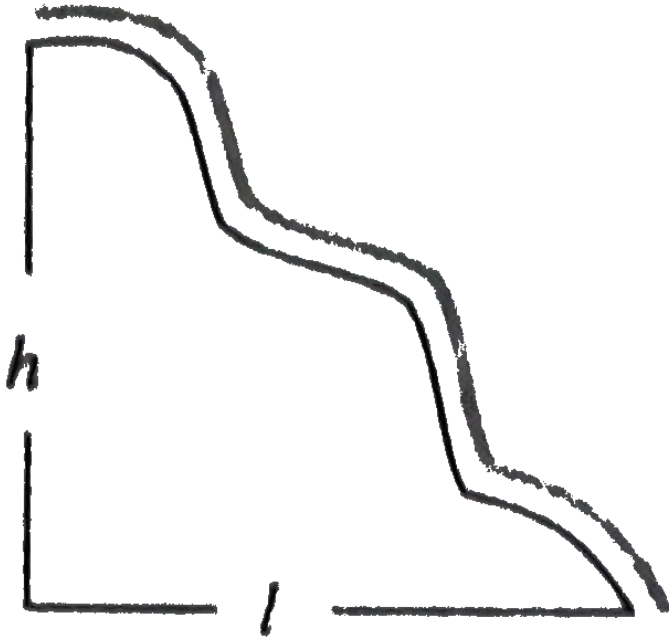

A. $\mu = \frac{h}{2l}$

$$\text{B. } \mu = \frac{h}{l}$$

$$\text{C. } \mu = \frac{3h}{2l}$$

$$\text{D. } \mu = \frac{2h}{3l}$$

Answer: b



Watch Video Solution

47. A block of mass m is at rest on a rough wedge as shown in figure. What is the force exerted by the wedge

on the block?

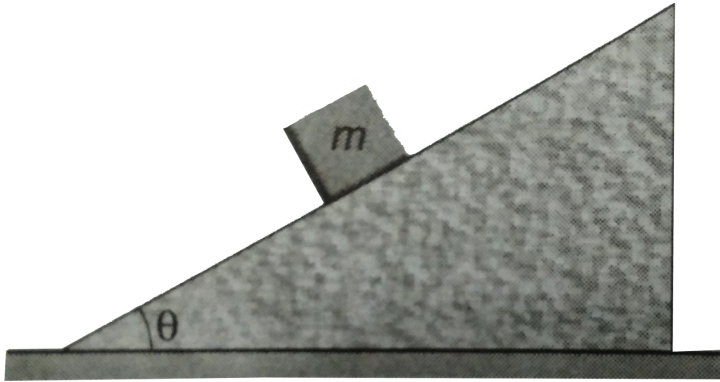

- A. Net force applied by m on M is mg
- B. Normal force applied by m on M is mg
- C. Force of friction applied by m on M is mg
- D. None of the above

Answer: A



Watch Video Solution

48. A triangular prism of mass m placed on it is released from rest on a smooth inclined plane of inclination θ . The block does not slip on the prism. Then

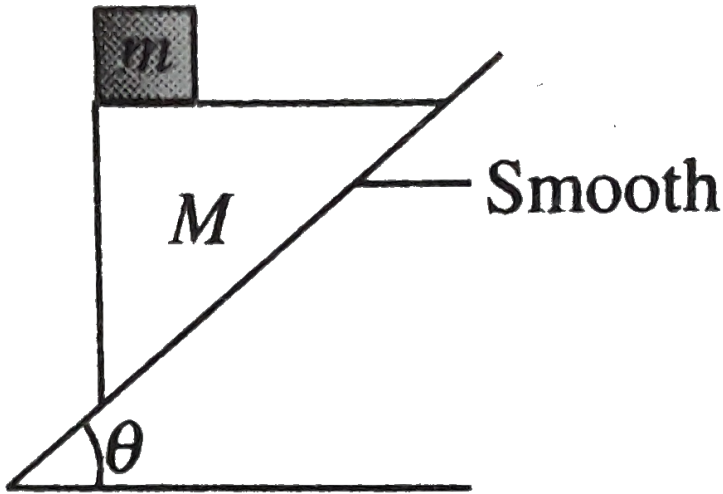

- A. The acceleration of the prism is $g \cos \theta$
- B. The acceleration of the prism is $g \tan \theta$
- C. The minimum coefficient of friction between the block and the prism is $\mu_{\min} = \cot \theta$

D. The minimum coefficient of friction between the block and the prism is $\mu_{\min} = \tan \theta$

Answer: d



Watch Video Solution

49. A block of mass m is kept on the floor of a freely falling lift. During the free fall of the lift, the block is pulled horizontally with a force of $F = 5N$, $\mu_s = 0.1$

The friction force on the block will be

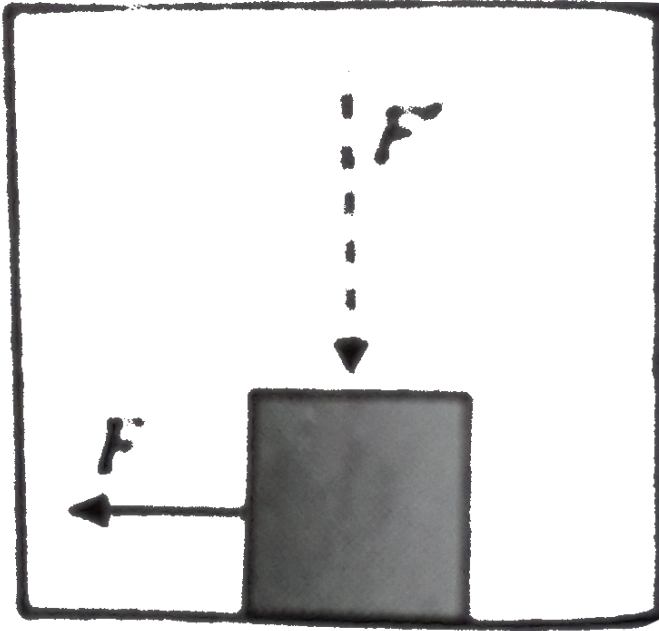

A. $5N$

B. $2N$

C. $0N$

D. $1N$

Answer: c



Watch Video Solution

50. If in pervious problem, an additional force $F' = 100N$ is applied in vertical direction as shown in figure The friction force acting on the block is

A. *zero*

B. $10N$

C. $20N$

D. $5N$

Answer: d



Watch Video Solution

51. A rectangular wooden box $10\text{cm} \times 20\text{cm} \times 40\text{cm}$ is kept on a horizontal surface with its largest face on the surface. A minimum force of 10N applied parallel to the surface sets the box in sliding motion along the surface. If the surface is frictionless, the minimum force applied parallel to the surface, to set the box in motion, is

- A. less than 10N
- B. May be greater or less than 10N
- C. greater than 10N
- D. equal to 10N

Answer: d



Watch Video Solution

52. Two blocks (m and M) are arranged as in figure
Then is friction between ground and M only and other
surface are frictionless between ground and
 M is $\mu = 0.25$ The maximum ratio of m and M (m/M)
so that the system remain is at rest

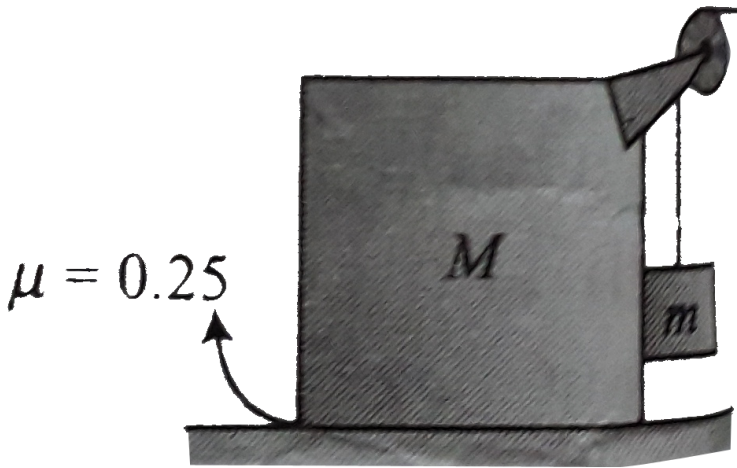

- A. $\frac{1}{3}$
- B. $\frac{1}{4}$

C. 3

D. none of these

Answer: a



Watch Video Solution

53. In the pulley arrangement shown in Fig the pulley p_2 is movable. Assuming the coefficient of friction between m and surface to be μ the minimum value of M for

which m is at rest is

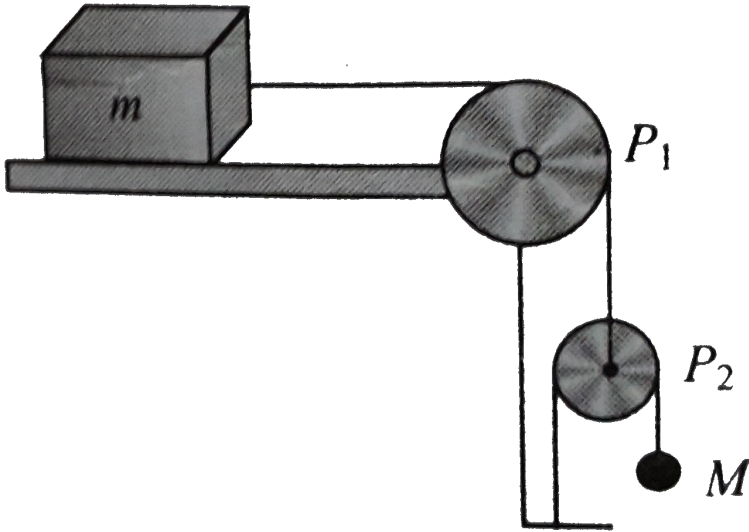

A. $M = \frac{\mu m}{2}$

B. $m = \frac{\mu M}{2}$

C. $M = \frac{m}{2\mu}$

D. $m = \frac{M}{2\mu}$

Answer: a



Watch Video Solution

54. In the arrangement shown in Fig there is no friction between of mass $2m$ and ground but there is friction between the block of masses m is stationary with respect to block of mass $2m$. The value of friction between m and $2m$ is

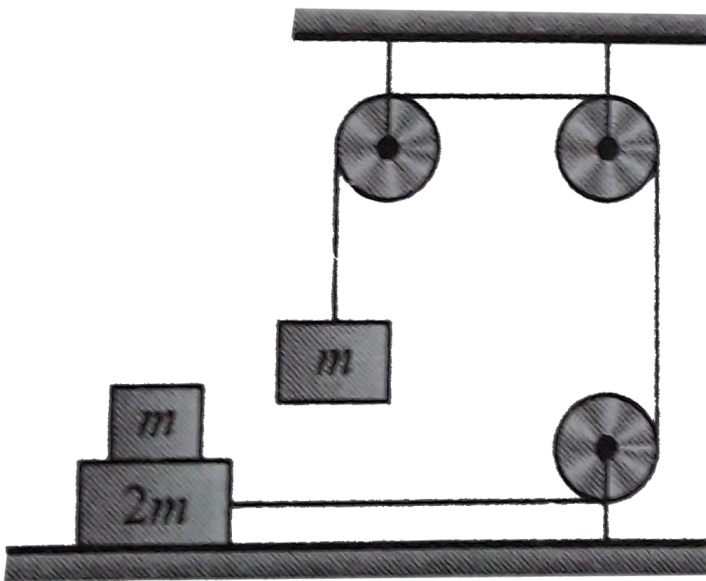

Smooth

A. $\frac{1}{2}$

B. $\frac{1}{\sqrt{2}}$

C. $\frac{1}{4}$

D. $\frac{1}{3}$

Answer: c



Watch Video Solution

55. A lift moving with a uniform velocity v in which a block of mass m is lying. The friction force offered by the when coefficient of friction is $\mu = 0.5$ will be

A. zero

B. $mg/2$

C. mg

D. $2mg$

Answer: a



Watch Video Solution

56. A block of mass is kept on an inclined plane of a lift moving down with acceleration of $2ms^{-2}$ What should be the minimum coefficient of friction to let the block

move down with constant velocity?

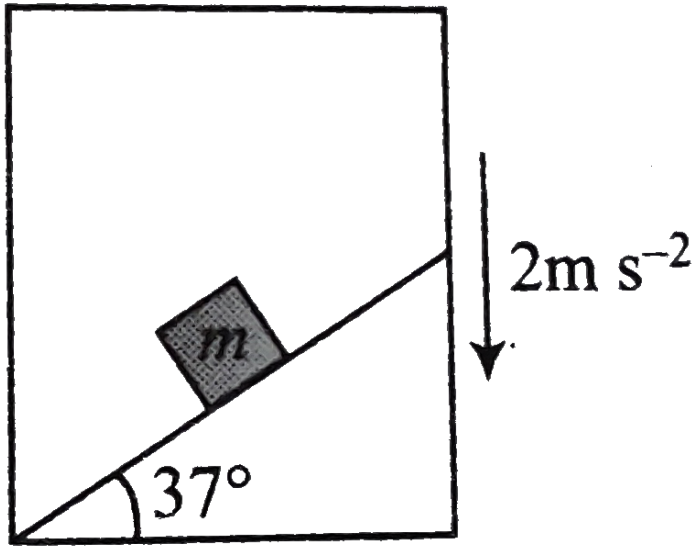

A. $\mu = \frac{1}{\sqrt{3}}$

B. $\mu = 0.4$

C. $\mu = 0.8$

D. $\mu =$ not defined

Answer: a

57. A system is pushed by a force F as shown in figure. All surfaces are smooth except between B and C is μ . Minimum value of F to prevent block B from downward slipping is

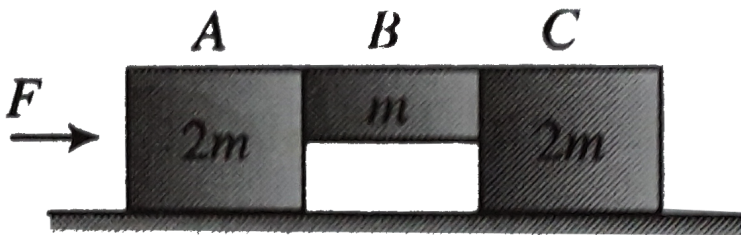

- A. $\left(\frac{3}{2\mu}\right)mg$
- B. $\left(\frac{5}{2\mu}\right)mg$
- C. $\left(\frac{5}{2}\right)\mu mg$
- D. $\left(\frac{3}{2}\right)\mu mg$

Answer: b



Watch Video Solution

58. A system is pushed by a force F as shown in figure
All surfaces are smooth except between B and C is μ .
Minimum value fo F to prevent block B from down
ward slipping is

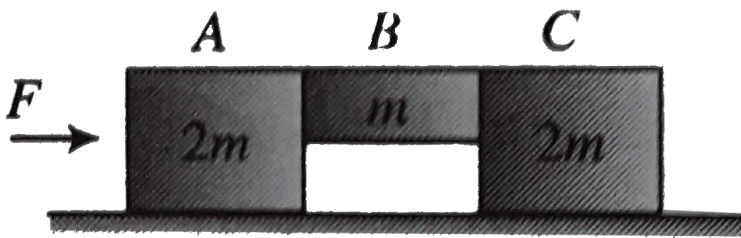

A. $\left(\frac{5}{3\mu}\right)mg$

B. $\left(\frac{5}{2\mu}\right)mg$

C. $\left(\frac{5}{2}\right)\mu mg$

D. None of these

Answer: a



Watch Video Solution

59. A block of mass M is being pulled along horizontal surface. The coefficient of friction between the block and the surface is μ . If another block of mass $M/2$ is placed on top of the block and it is again pulled on the surface, the coefficient of friction between the block and the surface will be

A. μ

B. $\frac{3\mu}{2}$

C. 2μ

D. $\frac{5\mu}{2}$

Answer: a



Watch Video Solution

60. Block A as shown in Fig weighs $2.0N$ and block B weighs $6.0N$ The coefficient of ikinetic friction between all surface is 0.25 Find the magnitude of the horizontal force necessary to drag block B to the left at constant speed if A and B are connected by a light , fixeible cord

passing around a fixed, frictionless pulley

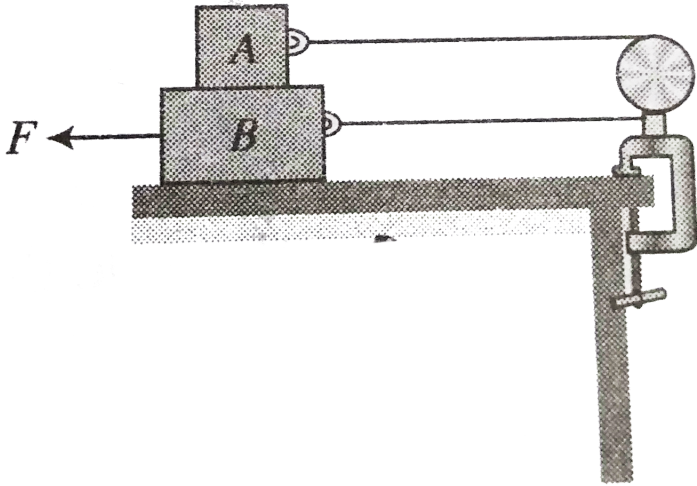

A. $2N$

B. $3N$

C. $5N$

D. $6N$

Answer: b



Watch Video Solution

61. Figure shown a wooden block at rest in equilibrium on a rough horizontal plane being acted upon by force $F_1 = 10N$, $F_2 = 2N$, as shown .IF F_1 is removed , the resulting force acting on the block will be

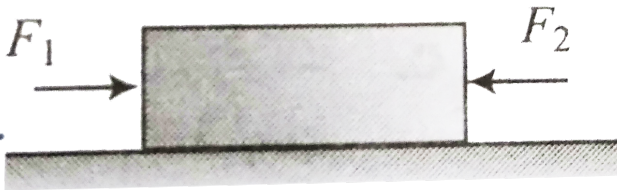

- A. $2N$ toward left
- B. $2N$ toward right
- C. $0N$
- D. cannot be determined

Answer: c



Watch Video Solution

62. A block of mass 2 kg is pushed against a rough vertical wall with a force of 40N. Coefficient of static friction being 0.5. Another horizontal force of 15 N, is applied on the block in a direction parallel to the wall. Will the block move? If yes in which direction? If no, find the frictional force exerted by the wall on the block.

A. will move at angle 37° with vertical with acceleration $5/2ms^{-2}$ downward.

B. will move at angle 37° with vertical with acceleration $5/2ms^{-2}$ upward.

C. will move at angle 45° with vertical with acceleration $5/2ms^{-2}$ downward.

D. none of these

Answer: a



Watch Video Solution

63. A stone of mass m tied to the end of a string revolves in a vertical circle of radius R . The net forces at the lowest and highest points of the circle directed vertically downwards are



T_1 and v_1 denote the tension and speed at the lowest point. T_2 and v_2 denote corresponding values at the highest point.

- A. Lowest point highest point
 $mg - T_1$ $mg + T_2$
- B. Lowest point highest point
 $mg + T_1$ $mg - T_2$
- C. Lowest point highest point
 $mg + T_1 - \frac{mv^2}{r}$ $mg - T_2 + \frac{mv^2}{r}$
- D. Lowest point highest point
 $mg - T_1 - \frac{m_1v_1^2}{R}$ $mg + T + \frac{m_1v_1^2}{R}$

Answer: a



Watch Video Solution

64. A smooth wire of length $2\pi r$ is bent into a circle and kept in a vertical plane. A bead can slide smoothly on the wire. When the circle is rotating with angular speed ω about the vertical diameter AB , as shown in figure, the bead is at rest with respect to the circular ring at position P as shown. then the value of ω^2 is

equal to :

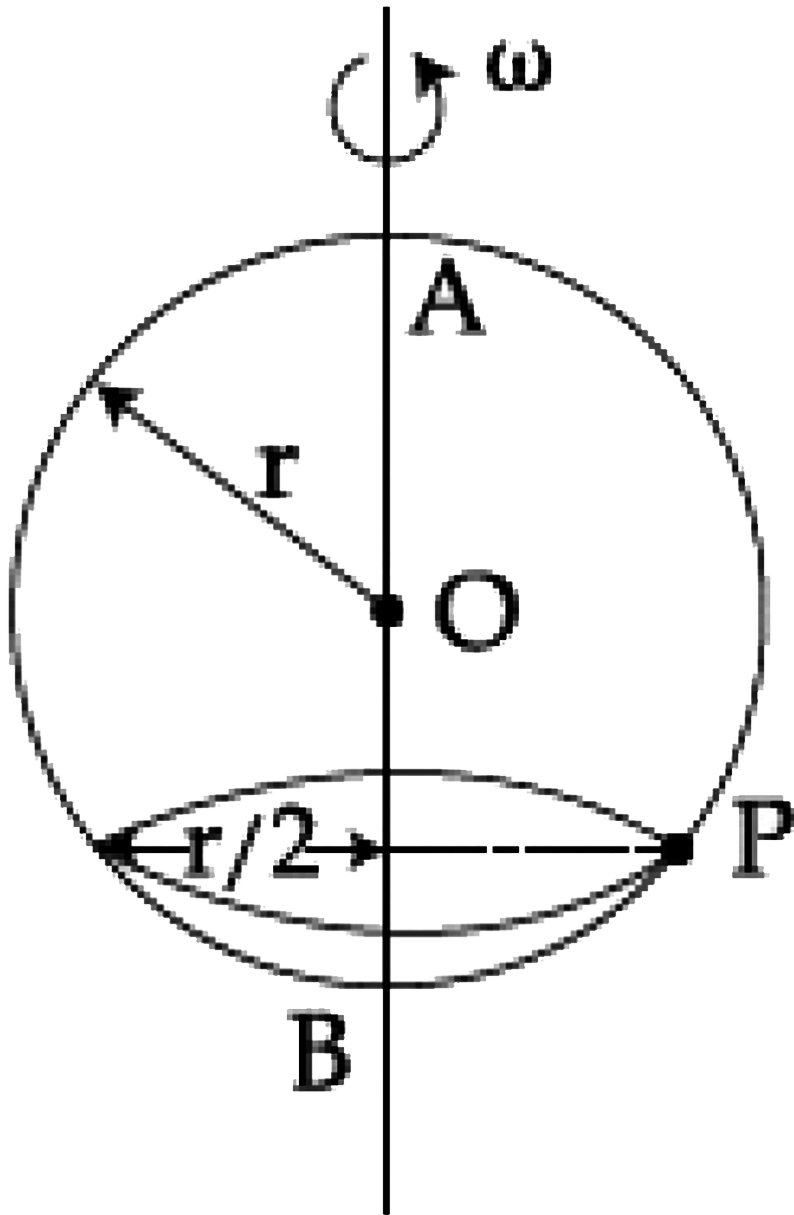

A. $\frac{2g}{a}$

B. $\frac{g}{2a}$

C. $\frac{2g}{a\sqrt{3}}$

D. $\frac{g\sqrt{3}}{2a}$

Answer: c



Watch Video Solution

65. When the string of a conical pendulum makes an angle of 45° with the vertical , its time is T_1 when the string makes an angle of 60° with the vertical , its time

period is T_2 then T_1^2 / T_2^2 is

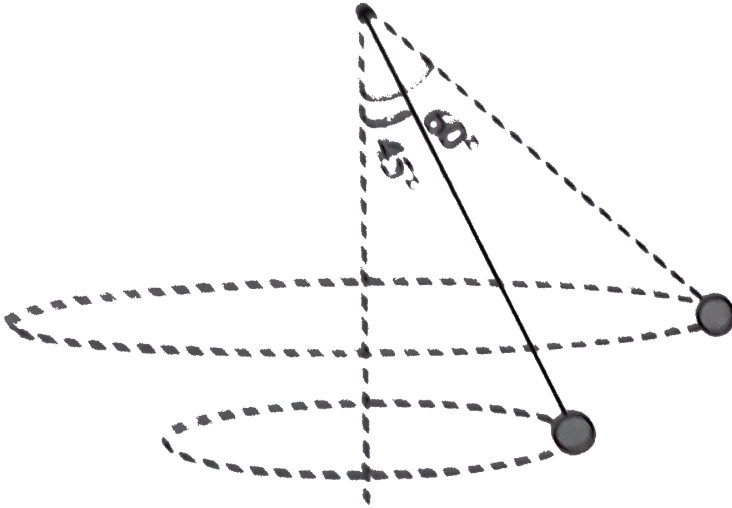

A. 2

B. $\sqrt{2}$

C. 0.5

D. none of these

Answer: b



Watch Video Solution

66. Three identical particles are joined together by a thread as shown in figure All the particles are moving in a horizontal plane. If the velocity of the outermost particle is v_0 , then the ratio of tension in the three sections of the string ($T_1 : T_2 : T_3 = ?$) is

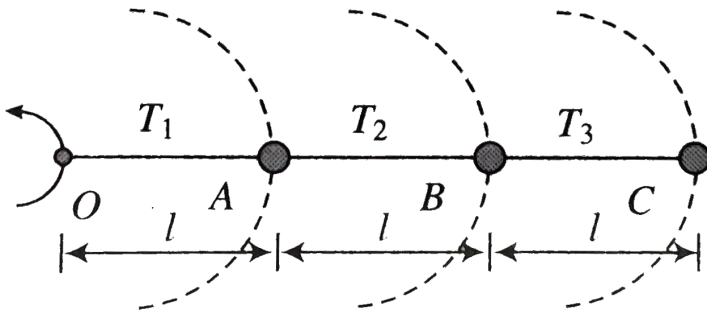

A. 6 : 5 : 3

B. 3 : 5 : 6

C. 3 : 4 : 5

D. none of these

Answer: A



Watch Video Solution

67. Two identical particles are attached at the end of a light string which passes through a hole at the center of a table. One of the particles is made to move in a circle on a table with angular velocity ω_1 and the other is made to move in a horizontal circle with angular velocity ω_2 if l_1 and l_2 are the lengths of the string from the hole to the particles, then in order that the particles do not slip under the table

neither moves down nor move up the ratio l_1 / l_2 is

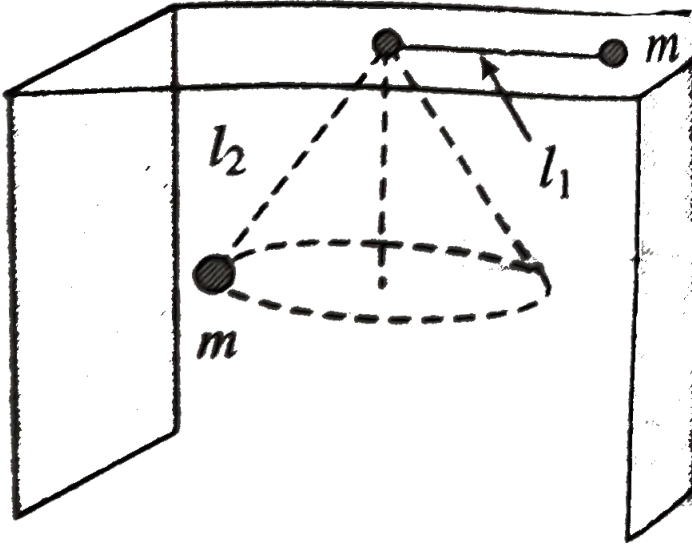

- A. $\frac{\omega_1}{\omega_2}$
- B. $\frac{\omega_2}{\omega_1}$
- C. $\frac{\omega_1^2}{\omega_2^2}$
- D. $\frac{\omega_2^2}{\omega_1^2}$

Answer: d



68. A block of mass m is revolving in a smooth horizontal plane with a constant speed v . If the radius of the circle path is R find the total contact force received by the block

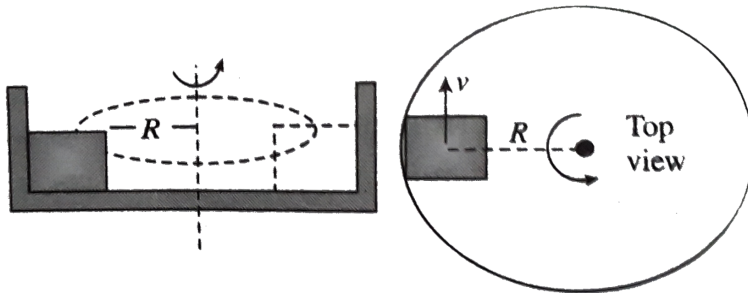

A. $\frac{mv^2}{R}$

B. mg

C. $m\sqrt{\frac{v^4}{R^2} + 4g^2}$

$$D. m \sqrt{\frac{v^4}{R^2} + g^2}$$

Answer: D



Watch Video Solution

69. A particle is projected with a speed $v_0 = \sqrt{gR}$. The coefficient of friction the particle and the hemispherical plane is $\mu = 0.5$ Then , the acceleration of the

partical is

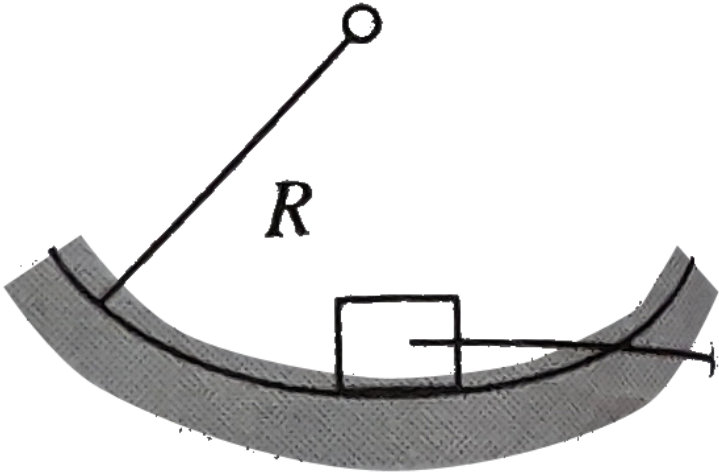

A. g

B. $\frac{\sqrt{5}g}{2}$

C. $\sqrt{2}g$

D. none of these

Answer: B



Watch Video Solution

70. A car travels with constant speed on a circular road level ground in figure F_{air} is the force of air resistance acts opposite to the motion of car which of the other forces shown best represents the horizontal force of the road on the car's tires?

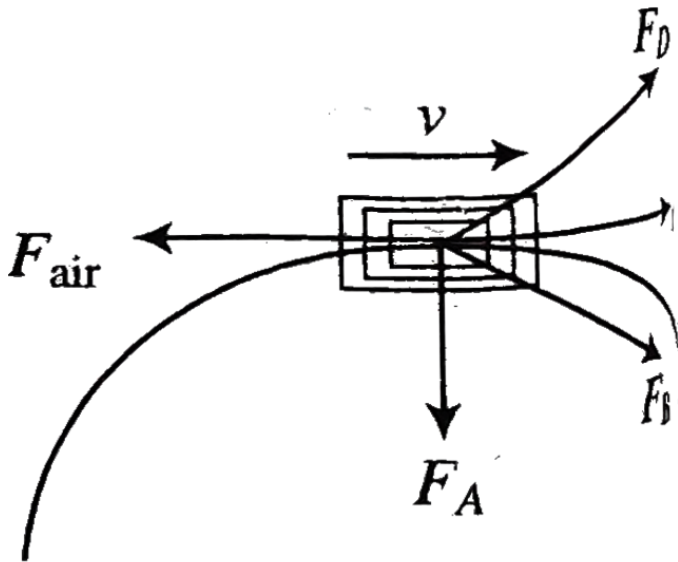

A. F_C

B. F_D

C. F_A

D. F_B

Answer: D



Watch Video Solution

71. A block of mass m is projected on a smooth horizontal circular track with velocity v what is the average normal force exerted by the circular walls on

the block during motion A to B?

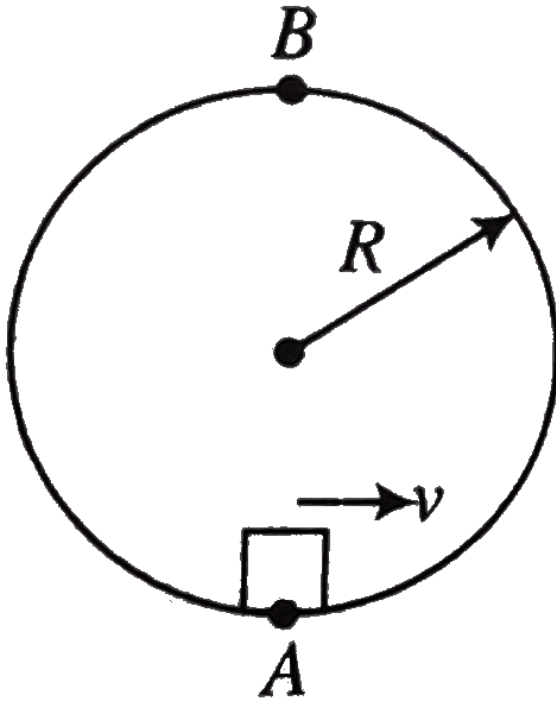

- A. $\frac{mv^2}{R}$
- B. $\frac{mv^2}{\pi R}$
- C. $\frac{2mv^2}{R}$
- D. $\frac{2mv^2}{\pi R}$

Answer: d



Watch Video Solution

72. In the figure shown q is in coulomb and t in second.

At time $t = 1s$

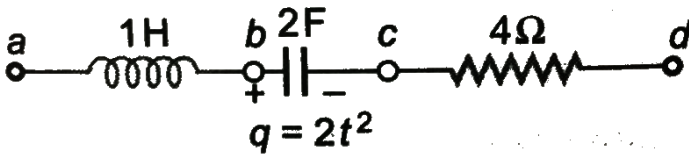

- A. Car A completes its journey before car B
- B. Both cars complete their journey in same time
- C. Velocity of car A is greater than that of car B
- D. Car B of car A is journey before carA

Answer: d



Watch Video Solution

73. Consider the setup is of a Ferris wheel in an amusement part. The wheel is turning in a counterclockwise manner. Contrary i.e. parallel to the x -axis. Determine the orientation of the normal to seat

as it passes point A

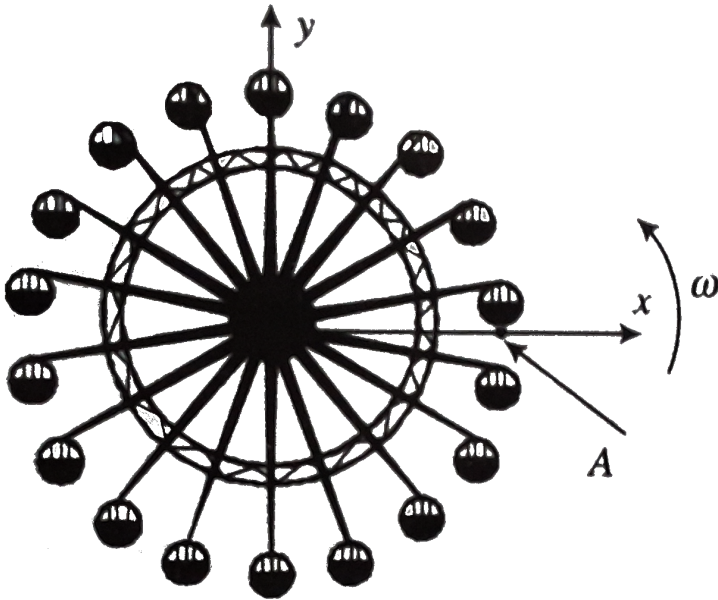

- A. parallel to the x-axis
- B. in the first/third quadrants
- C. parallel to the y-axis
- D. in the second/fourth quadrants

Answer: d



74. Two blocks of masses m_1 and m_2 are connected through a massless inextensible string. A block of mass m_1 is placed at the fixed rigid inclined surface while the block of mass m_2 hanging at the other end of the string which is passing through a fixed massless frictionless pulley shown in figure. The coefficient of static friction between the block and the inclined plane is 0.8. The system of masses m_1 and m_2 released from

rest

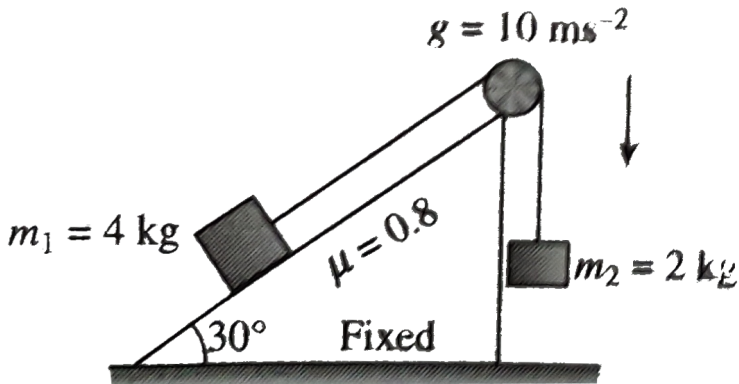

- A. The tension in the string is 20 N after releasing the system
- B. The contact force by the inclined surface on the block is along normal to the inclined surface
- C. The magnitude of contact force by the inclined surface on the m_1 is $20\sqrt{3} \text{ N}$
- D. None of these

Answer: a,b,c

 Watch Video Solution

75. In Fig if $F = 4N$, $m = 2kg$ $M = 4kg$ then

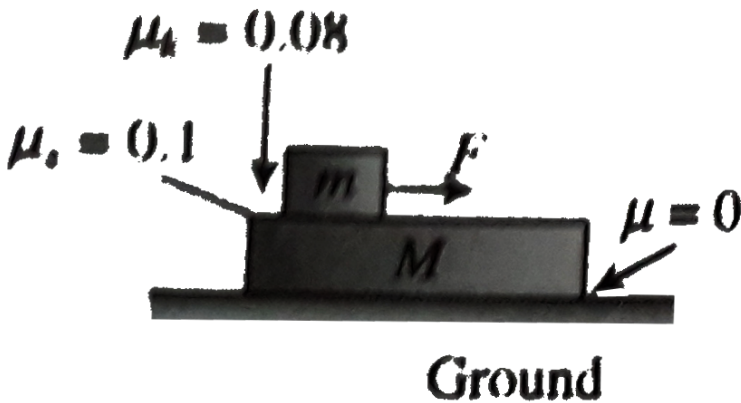

- A. The acceleration of m w.r.t. ground is $2/3ms^{-2}$
- B. The acceleration of m w.r.t. ground is $1.2ms^{-2}$
- C. Acceleration of M is $0.4ms^{-2}$

D. Acceleration of M w.r.t. ground is $2/3ms^{-2}$

Answer: b,c

 [Watch Video Solution](#)

76. A $20kg$ blocks is placed on of $50kg$ block as shown in figure An horizontal force F acting on A causes an acceleration of $3ms^{-2}$ to A and $2ms^{-2}$ to B as shown in the figure for this situation mark out the corect statement(s)

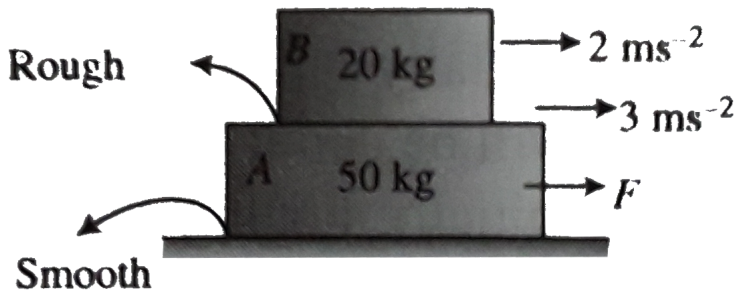

A. The friction force between A and B is $40N$

B. The net force acting on A is $150N$

C. The value of F is $190N$

D. The value of F is $150N$

Answer: a,b,c



Watch Video Solution

77. Find the acceleration of the two blocks . The system is initially at rest and the friction are as shown in fig

.Given $m_A = m_B = 10\text{kg}$

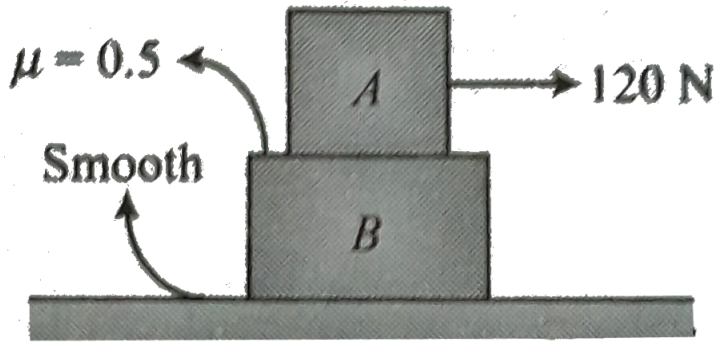

- A. on A supports its motion
- B. on B opposes its motion relative to A
- C. on B oppose its motion
- D. oppose the motion of both

Answer: a,b,c



Watch Video Solution

78. Two rough blocks A and B, A placed over B move with acceleration \vec{a}_A and \vec{a}_B velocities $\vec{v}(A)$ and \vec{v}_B by the action of horizontal forces \vec{F}_A and \vec{F}_B , respectively. When no friction exists between the blocks A and B,

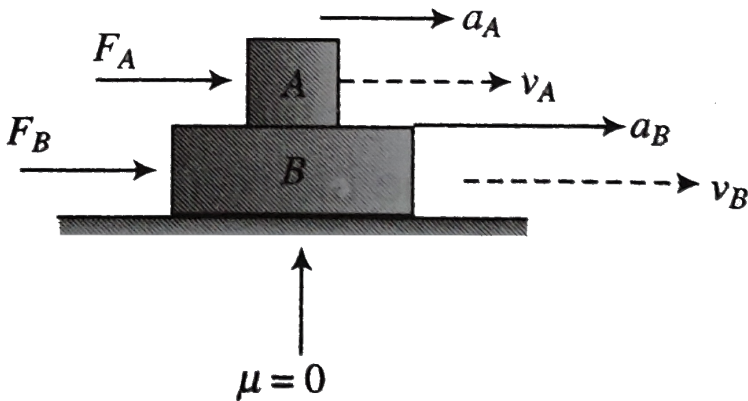

A. $v_A = v_B$

B. $a_A = a_B$

C. Both (a) and (b)

D. $\frac{F_A}{m_A} = \frac{F_B}{m_B}$

Answer: a,b,c,d,



Watch Video Solution

79. Mark the correct statement (s) regarding friction .

A. Friction force can be zero though the contact surface is rough

B. Even though there is no relative motion between surface friction force may exist between them

C. The expressions $f_L = \mu_s N$ or $f_k = \mu_s N$ are approximate expressions

D. The expression $f_L = \mu_s N$ tells that the direction of f_L and N are the same.

Answer: a,b,c

 [Watch Video Solution](#)

80. A 3kg block of wood is on a level surface where $\mu_s = 0.25$ and $\mu_k = 0.2$. A force of 7N is being applied horizontal to the block. Mark the correct statement(s) regarding this situation.

A. If the block is initially at rest, it will remain at rest and friction force will be about 7N

B. If the block is initially moving then it will continue its motion forever if the force applied is in the direction of the motion of the block

C. If the block is initially moving and the direction of applied force is opposite to that of motion of block, then block moves with an acceleration of $1/3 \text{ m s}^{-2}$ along its initial direction of motion

D. If the block is initially moving and direction of applied force is opposite to that of initial motion of the block then the block decelerates, comes to a stop and starts moving in the opposite direction.

Answer: a,b,c



Watch Video Solution

81. A block is resting over a rough horizontal floor. At $t = 0$ a time-varying force starts acting on it, the force is described by equation $F = kt$ where k is constant and r is in seconds. Marks the correct statement (s) for

this situation .

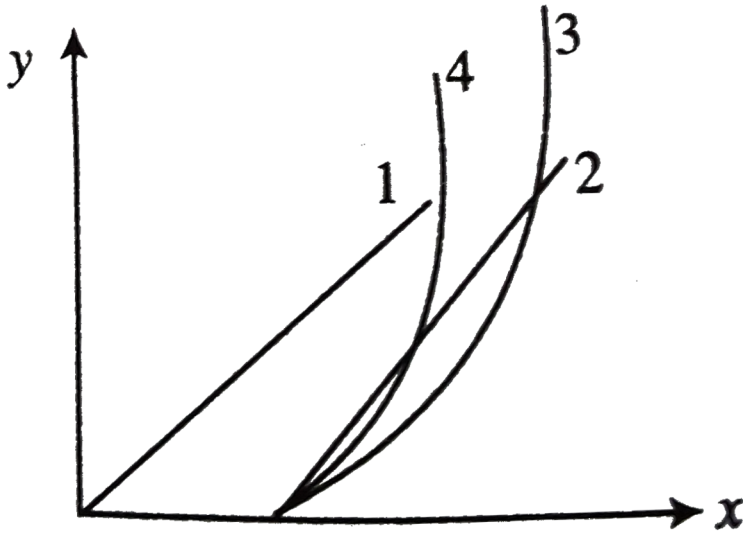

- A. Curve 1 shows acceleration - time graph
- B. Curve 2 shows acceleration - time graph
- C. Curve 3 shows velocity - time graph
- D. Curve 4 shows displacement - time graph

Answer: b



Watch Video Solution

82. Two blocks A and B of masses $5kg$ and $2kg$ respectively connected by a spring of force constant $= 100Nm^{-1}$ are placed on an inclined plane of inclined 30° as shown in figure If the system is released from rest

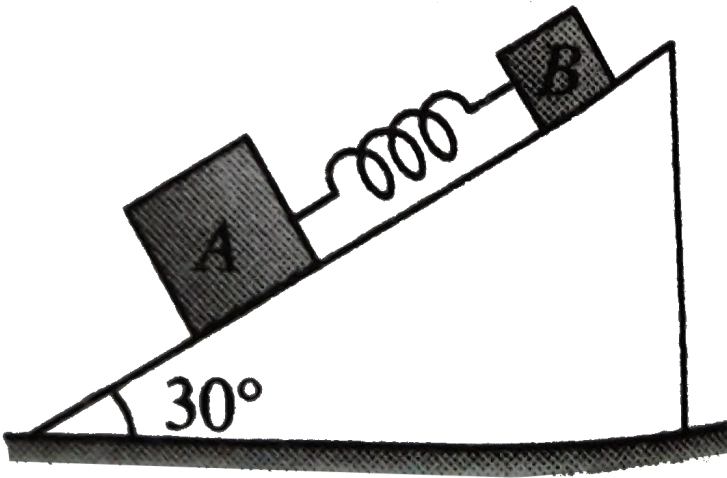

A. There will be no compression or elongation in the spring if all surface are smooth

B. There will be no compression or elongation in the spring if A is rough and B is smooth

C. Maximum elongation in the spring 35cm If all surface are smooth

D. There will be no compression or elongation in the spring if A is smooth and B is rough

Answer: a,d



Watch Video Solution

83. The coefficient of friction between the two two blocks is 0.3 where as the surface AB is smooth

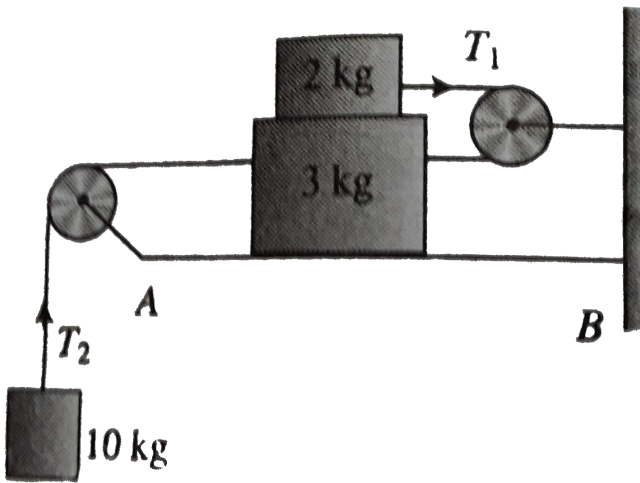

- A. Acceleration of the system masses is $88/15 m s^{-2}$
- B. Net force acting on $3 kg$ mass is greater than that on $2 kg$ mass
- C. Tension $T_2 > T_1$
- D. Since $10 kg$ mass is acceleration downward, so the net force acting on it should be greater than any of the two blocks shown in figure

Answer: a,b,c



Watch Video Solution

84. A 10kg block is placed on top of a 40kg block as shown in figure .A horizontal force F acting on B cause an acceleration of 2m.s^{-2} to B .For this situation marks our the correct statement(s)

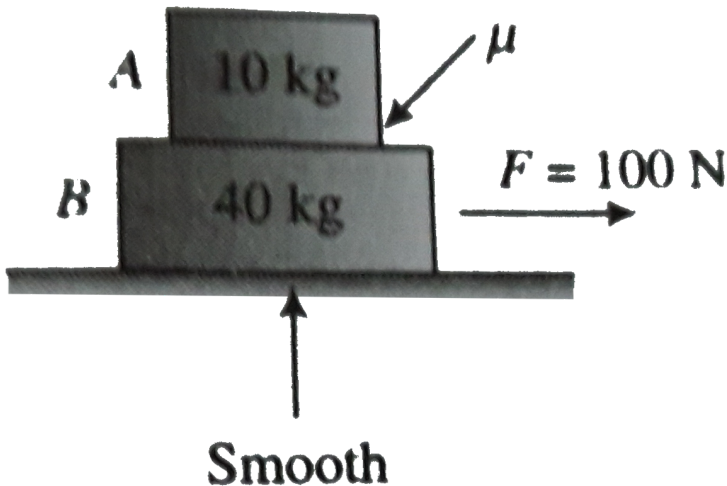

- A. The acceleration of A may be $2ms^{-2}$ or less than $2ms^{-2}$
- B. The acceleration of A mass also be $2ms^{-2}$
- C. The coefficient of friction between the blocks may be 0.2
- D. The coefficient of friction between the blocks must be 0.2 only

Answer: b,c



Watch Video Solution

85. A car moving along a circular track of radius $50.0m$ acceleration from rest at $3.00ms^{-2}$ Consider a situation when the car's centripetal acceleration equal its tangential acceleration

A. The angle around the track does the car travel is

1 rad

B. The magnitude of the car's total acceleration at

that is $3\sqrt{2}ms^{-1}$

C. Time elapses before this situation is $\sqrt{\frac{50}{3}}s$

D. The distance travelled by the car during this time

$25m$

Answer: b,c,d



Watch Video Solution

86. A particle of m_1 moves in a circular path of radius R on a rotating table. A string connecting the particles m_1 and m_2 passes over a smooth hole made on the table as shown in figure. If mass m_1 does not slide relative to the rotating table, mark the correct option as

applicable.

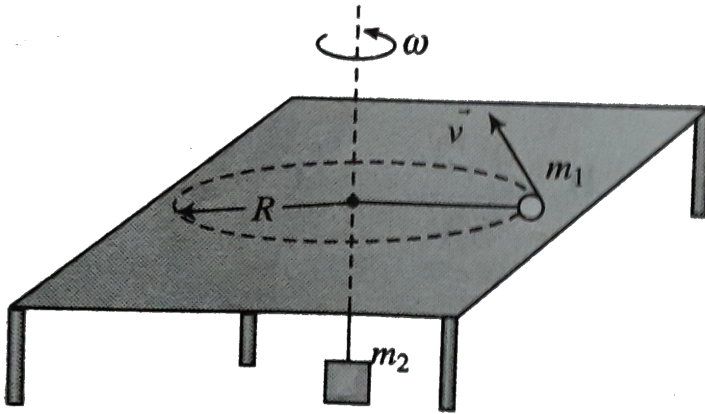

A. The friction force acting on the block

m_1 is $(m_1\omega^2 R - m_2g)$ along radial rotation

towards center of rotation

B. The friction force acting on the block

m_1 is $(m_1\omega^2 R - m_2g)$ along tangential direction

in the direction opposite to \vec{v}

C. The maximum angular velocity of the particle is

$$\sqrt{\left(\frac{m_2 + \mu m_1}{m_1}\right) \frac{g}{R}}$$

D. The minimum angular velocity of the particle is

$$\sqrt{\left(\frac{m_2 - \mu m_1}{m_1}\right) \frac{g}{R}}$$

Answer: a,c,d



Watch Video Solution

87. Block B rests on a smooth surface .The coefficient of static friction between A and B is $\mu = 0.4$ where $F = 30N$ then

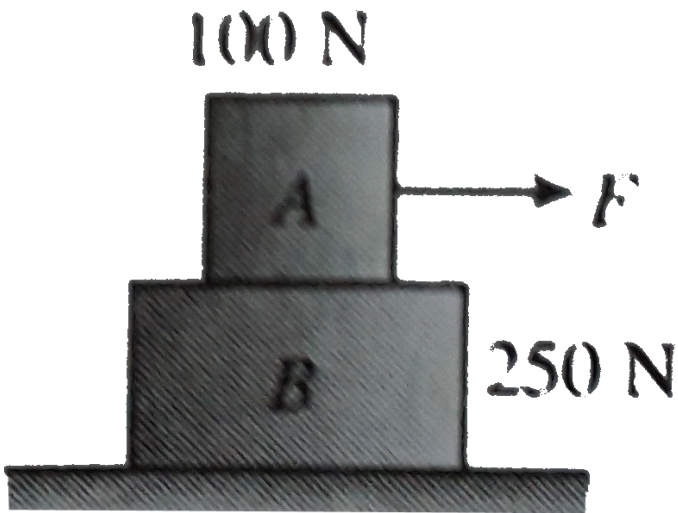

Acceleration of upper block is

A. $3/2\text{ms}^{-2}$

B. $6/7\text{ms}^{-2}$

C. $4/3\text{ms}^{-2}$

D. $3/7\text{ms}^{-2}$

Answer: B



Multiple Correct

1. Block B rests on a smooth surface. The coefficient of static friction between A and B is $\mu = 0.4$ where $F = 30\text{N}$ then

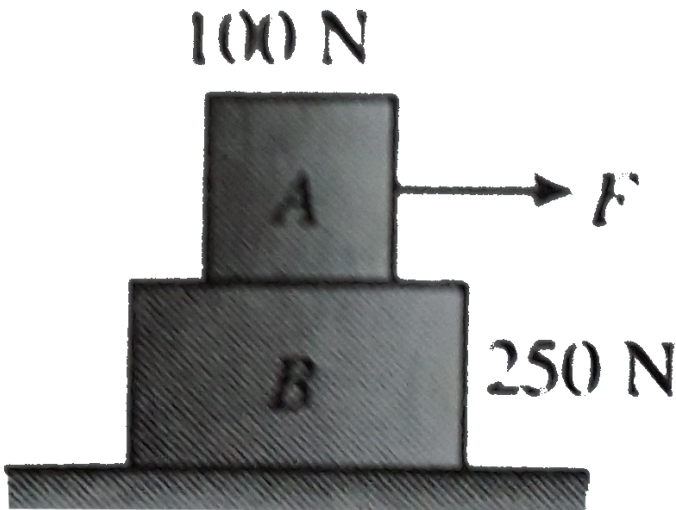

Acceleration of upper block is

A. $3/7ms^{-2}$

B. $4/3ms^{-2}$

C. $6/7ms^{-2}$

D. $3/2ms^{-2}$

Answer: c



Watch Video Solution

2. Block B rests on a smooth surface . If the coefficient of static friction between A and B is $\mu = 0.4$.

Determine the acceleration of each , if

(a) $F = 30N$ and

(b) $F = 250N (g = 10m/s^2)$

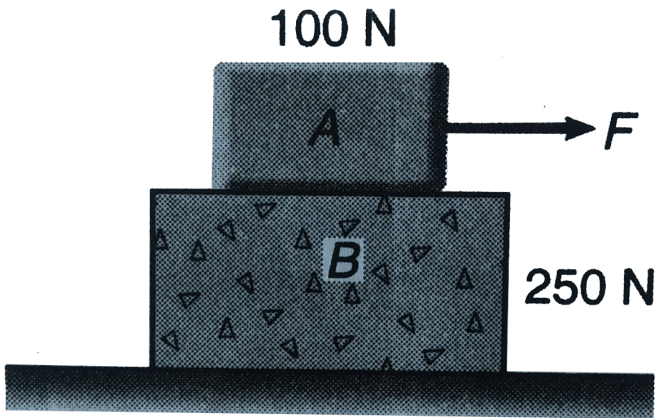

A. $4/5ms^{-2}$

B. $3/2ms^{-2}$

C. $3/5ms^{-2}$

D. $8/5ms^{-2}$

Answer: d



Watch Video Solution

Linked Comprehension

1. A monkey of mass m clings a rope to a slung over a fixed pulley. The opposite end of the rope is tied to a weight of mass M lying on a horizontal table. The coefficient of friction between the weight and the table is μ . Find the acceleration of weight M . The monkey moves downward with respect to the rope with an acceleration b .

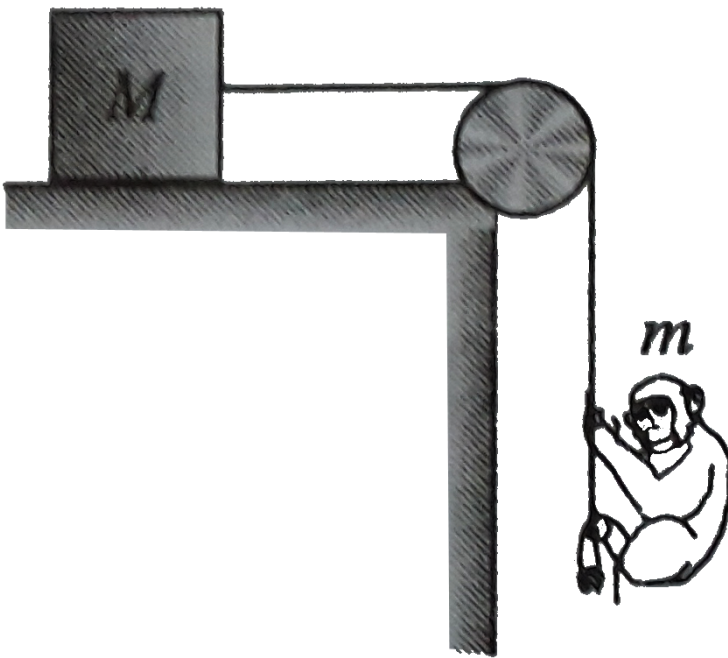

The acceleration of weight is

A.
$$\frac{2m(g + b) - \mu Mg}{M + 2m}$$

B.
$$\frac{m(g + b) - \mu Mg}{2(M + m)}$$

C.
$$\frac{m(g + b) - 3\mu Mg}{M + 3m}$$

D.
$$\frac{m(g + b) - \mu Mg}{M + 2m}$$

Answer: d



Watch Video Solution

2. A monkey of mass m clings a rope to a slung over a fixed pulley. The opposite end of the rope is tied to a weight of mass M lying on a horizontal table. The coefficient of friction between the weight and the table is μ . Find the acceleration of weight and the tension of the rope for two cases. The monkey moves downward with respect to the rope with an acceleration b .

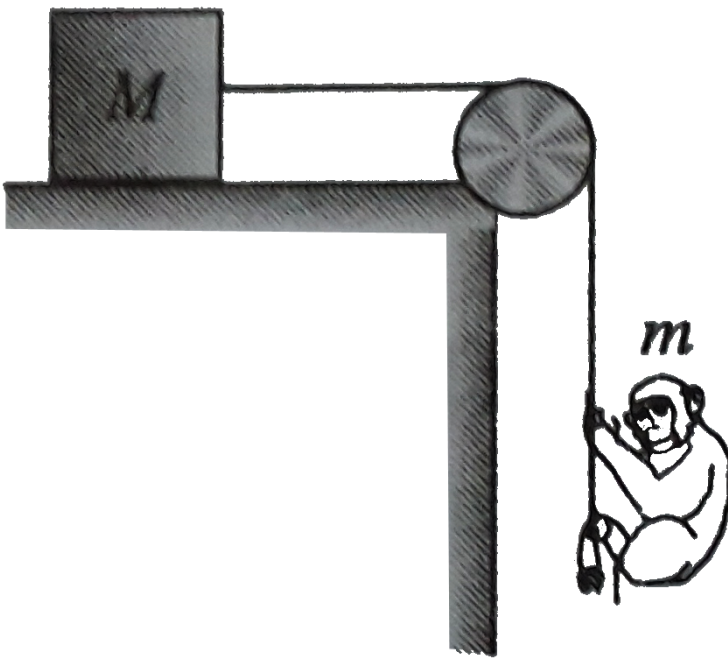

The tension of rope is

A. $\frac{Mm(\mu g + g + b)}{M + m}$

B. $\frac{Mm(\mu g - g + b)}{M + m}$

C. $\frac{Mm(\mu g + g - b)}{M + m}$

D. $\frac{Mm(\mu g - g - b)}{M + m}$

Answer: c



3. Block A weight $4N$ and block B weight $8N$ The coefficient of kinetic friction is 0.25 for all surface. Find F to slide B at constant speed when

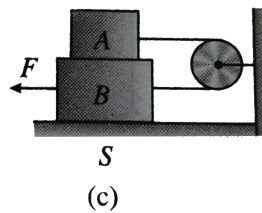
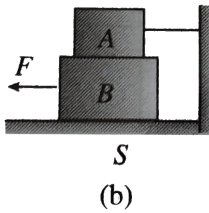
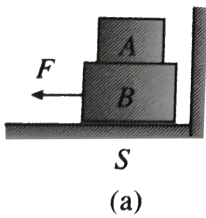

A is held at rest

A. $2N$

B. $3N$

C. $4N$

D. $5N$

Answer: b



Watch Video Solution

4. Block A weighs $4N$ and block B weighs $8N$. The coefficient of kinetic friction is 0.25 for all surfaces. Find the force F to slide B at a constant speed when (a) A rests on B and moves with it (b) A is held at rest and (c) A and B are connected by a light cord passing over a smooth pulley as shown in fig 7.31 (a - c) respectively.

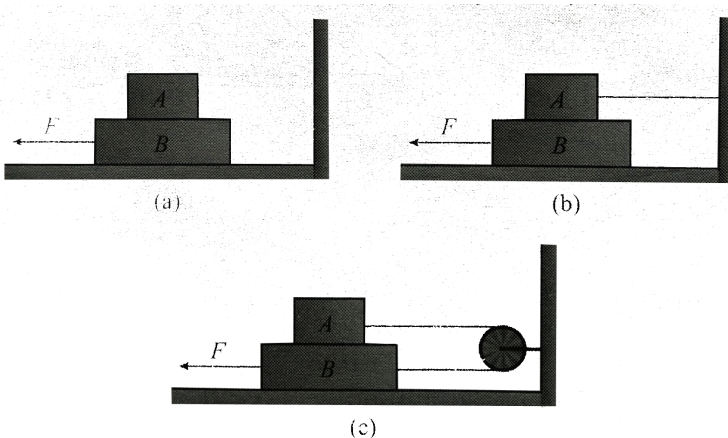

A. $2N$

B. $3N$

C. $4N$

D. $5N$

Answer: c



Watch Video Solution

5. Block A as shown in figure weight $1.40N$ and block B weight $4.20N$ The coefficient of kinetic friction between all surface is 0.30 Find the magnitude of the horizontal force necessary to drag block B to the left at constant speed if A and B are connected by a light , flexible cort

passing around a fixed, frictionless pulley.

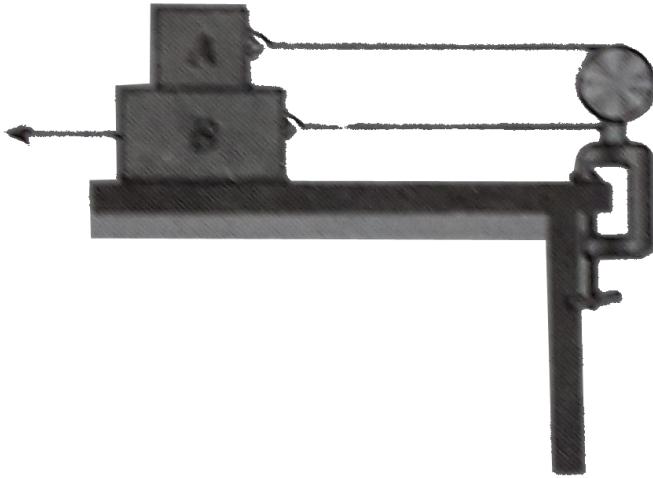

A. $2N$

B. $3N$

C. $4N$

D. $5N$

Answer: d

 [Watch Video Solution](#)

6. Block A of mass m and block B of mass $2m$ are placed on a fixed triangular wedge by means of a massless inextensible string and a frictionless pulley as shown in figure. The wedge is inclined at 45° to the horizontal on both sides. The coefficient of friction between blocks A and the wedge is $\frac{2}{3}$ and that between block B and the wedge is $\frac{1}{3}$. The system is released from rest. Find the following:

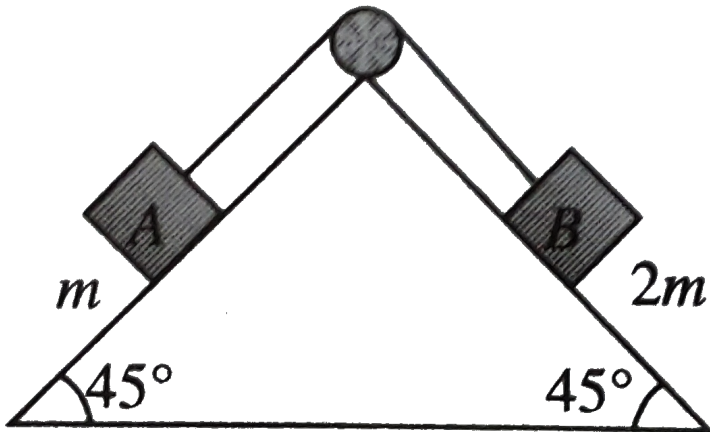

The acceleration of A is

A. $\frac{g}{3\sqrt{2}}$

B. Zero

C. $(g)(\sqrt{7})$

D. $\frac{g}{2\sqrt{3}}$

Answer: b



Watch Video Solution

7. Block A of mass m and block B of mass $2m$ are placed on a fixed triangular wedge by means of a massless inextensible string and a frictionless pulley as shown in figure. The wedge is inclined at 45° to the horizontal on both sides. The coefficient of friction between blocks A

and the wedge is $2/3$ and that between block B and is released from rest find the following

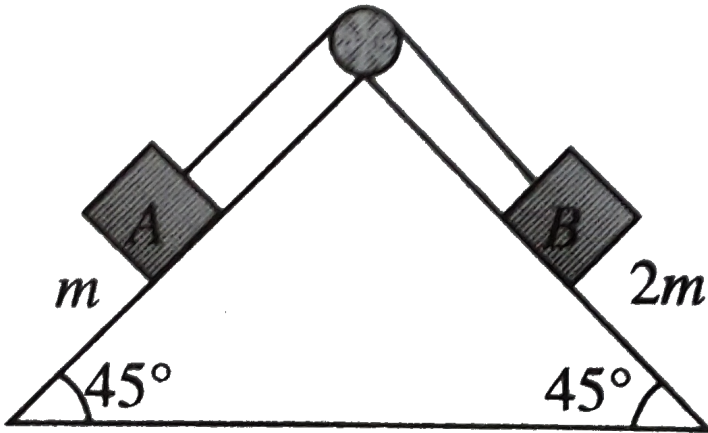

The tension in the string is

- A. $\frac{3}{\sqrt{5}}mg$
- B. $\frac{5}{3\sqrt{2}}mg$
- C. $\frac{2\sqrt{2}mg}{3}$
- D. $\frac{mg}{5}$

Answer: c



Watch Video Solution

8. Block A of mass m and block B of mass $2m$ are placed on a fixed triangular wedge by means of a massless inextensible string and a frictionless pulley as shown in figure. The wedge is inclined at 45° to the horizontal on both sides. The coefficient of friction between blocks A and the wedge is $\frac{2}{3}$ and that between block B and the wedge is $\frac{1}{3}$. The system is released from rest. Find the following:

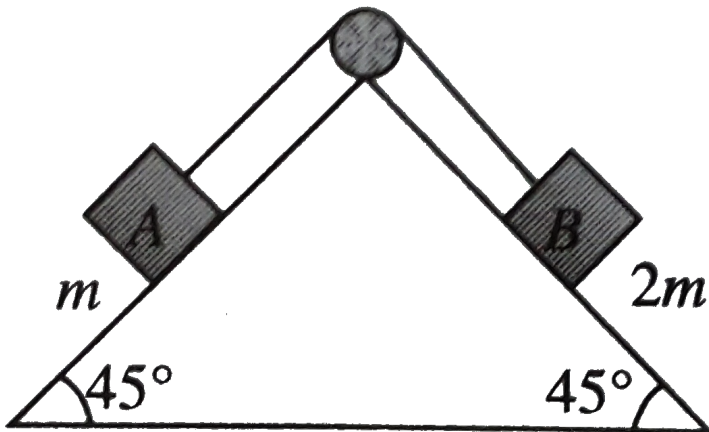

The magnitude and direction of the force of friction acting on A are

- A. mg down the plane
- B. $\frac{mg}{2}$ up the plane
- C. $\frac{mg}{\sqrt{2}}$, up the plane
- D. $\frac{mg}{3\sqrt{2}}$ down the plane

Answer: D



Watch Video Solution

9. Two forces F_1 and F_2 are acting on a rod abc as shown in figure.

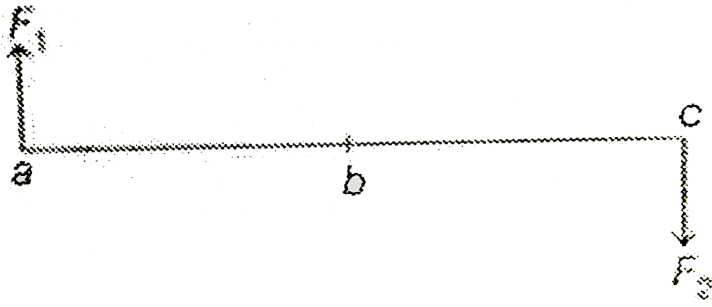

A. $\sqrt{31}N$

B. $\sqrt{26}N$

C. $\sqrt{41}N$

D. $\sqrt{36}N$

Answer: c



Watch Video Solution

10. A block of mass 10kg is kept on a rough floor. The coefficient of friction between floor and block are $\mu_s = 0.4$ and $\mu_k = 0.3$ forces $F_1 = 5\text{N}$ and $F_2 = 4\text{N}$ are applied on the block as shown in figure

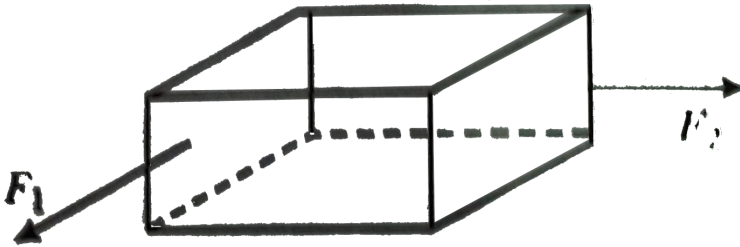

If $F_1 = 5\text{N}$ and $F_2 = a\text{N}$ for what maximum value of a the motion of block impendride?

A. $\sqrt{1557}\text{N}$

B. $\sqrt{1225}\text{N}$

C. $\sqrt{1664}\text{N}$

D. $\sqrt{875}N$

Answer: a



Watch Video Solution

11. Block A has mass $40kg$ and B has $15kg$ and F is $500N$ parallel to smooth inclined plane. The system is moving together

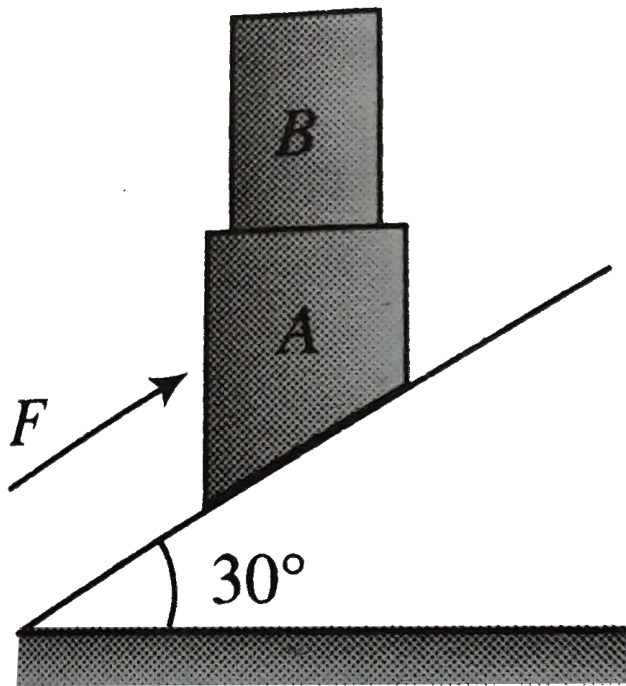

The acceleration of the system is

A. $\frac{45}{11}ms^{-2}$

B. $\frac{23}{11}ms^{-2}$

C. $\frac{13}{7}ms^{-2}$

D. $\frac{8}{3}ms^{-2}$

Answer: a



Watch Video Solution

12. Block A has mass 40kg and B has 15kg and F is 500N parallel to smooth inclined plane. The system is moving together

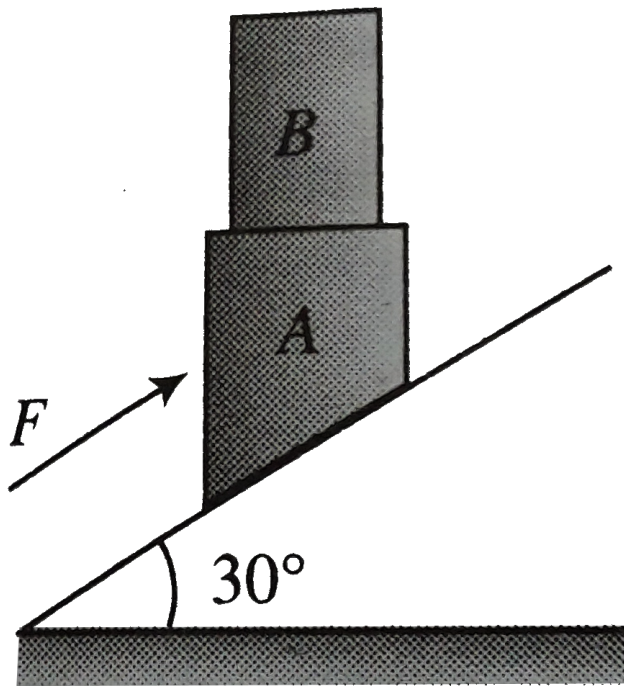

The least coefficient of friction between A and B is

- A. $\frac{5\sqrt{2}}{12}$
- B. $\frac{9\sqrt{3}}{53}$
- C. $\frac{9\sqrt{2}}{28}$
- D. $\frac{5\sqrt{3}}{18}$

Answer: B

 Watch Video Solution

13. A 10kg block rests on a 5kg bracket as shown in figure. The 5kg bracket rests on a horizontal surface. The coefficient of friction between the 10kg block and the bracket on which it rests are $\mu_s = 0.40$ and $\mu_k = 0.30$.

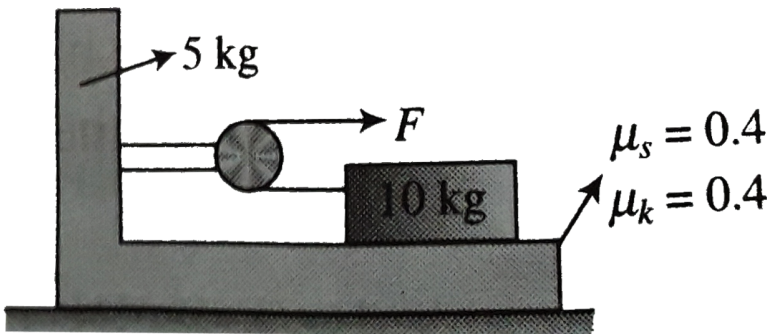

The maximum force F that can be applied if the 10kg block is not to slide on the bracket is

A. $32N$

B. $24N$

C. $18N$

D. $48N$

Answer: b



Watch Video Solution

14. A $10kg$ block rests on a $5kg$ bracket as shown in figure. The $5kg$ bracket rests on a horizontal surface. The coefficient of friction between the $10kg$ block and the bracket on which it rests are $\mu_s = 0.40$ and $\mu_k = 0.30$

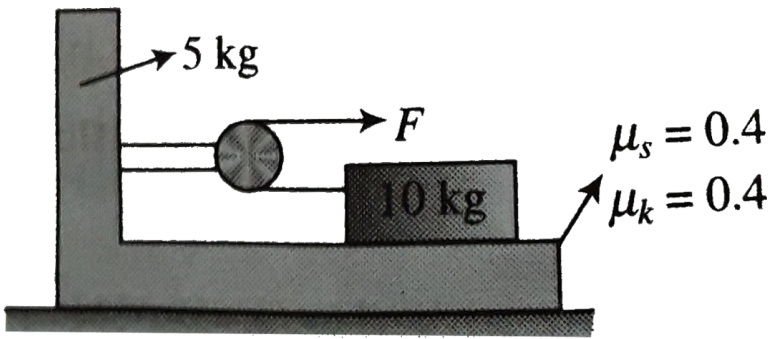

If the 10kg block is not to slide on the bracket , the corresponding acceleration of the 5kg bracket is

- A. 1.6ms^{-2}
- B. 0.8ms^{-2}
- C. 1.2ms^{-2}
- D. 2.4ms^{-2}

Answer: a

[Watch Video Solution](#)

15. A sufficiently long plane of mass $4kg$ is placed on a smooth horizontal surfaces A small block of mass $2kg$ is placed over the plank and is being acted upon by a time varying horizontal force $F = (0.5t)$ where F is in newton and t is in second as shown in figure. The coefficient of friction slipping the plank and the block is given is $\mu_s = \mu_k = \mu$, at time $t = 12s$ the relative slipping between the plank and the block is just likely to occur

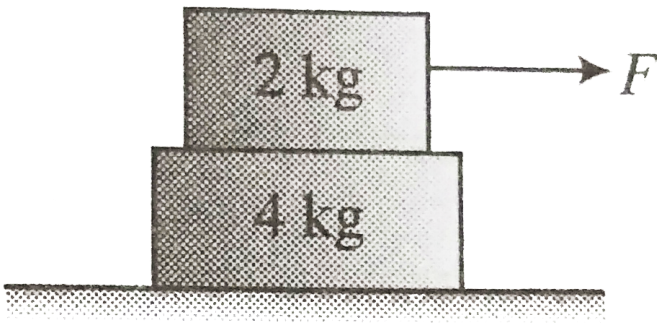

The coefficient of friction μ is equal to

- A. 0.10
- B. 0.15
- C. 0.20
- D. 0.30

Answer: c

 [Watch Video Solution](#)

16. A sufficiently long plank of mass 4kg is placed on a smooth horizontal surface. A small block of mass 2kg is placed over the plank and is being acted upon by a time varying horizontal force $F = (0.5t)$ where f is in newton and t is in second as shown in figure. The coefficient of friction slipping the plank and the block is given is $\mu_s = \mu_k = \mu$ time $t = 12\text{s}$ the relative slipping between the plank and the block is just likely to occur

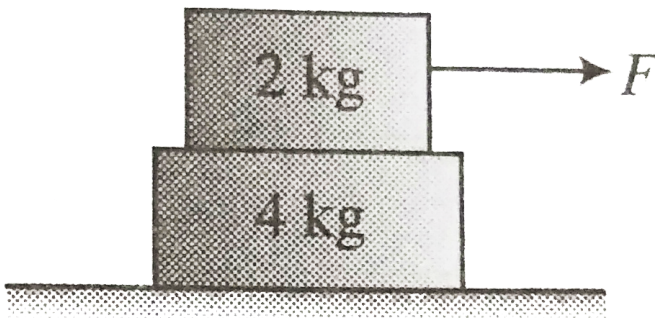

The acceleration a versus time t graph for the and the block shown in figure below is correctly represented in

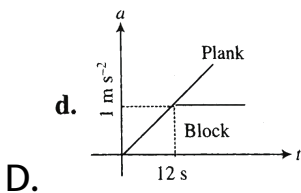
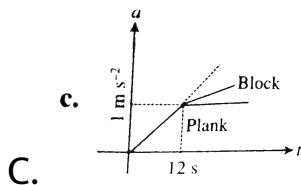
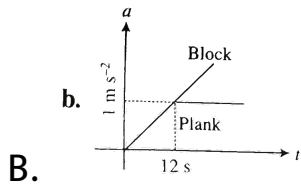
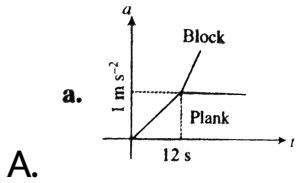

Answer: a



Watch Video Solution

17. A sufficiently long plank of mass 4kg is placed on a smooth horizontal surface. A small block of mass 2kg is placed over the plank and is being acted upon by a time varying horizontal force $F = (0.5t)$ where f is in newton and t is in second as shown in figure. The coefficient of friction slipping the plank and the block is given is $\mu_s = \mu_k = \mu$ time $t = 12\text{s}$ the relative slipping between the plank and the block is just likely to occur

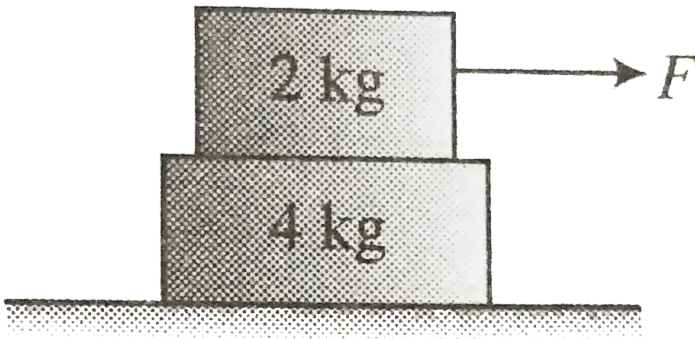

The average acceleration of the plank in the time interval $0 \rightarrow 15\text{s}$ in the figure will be

A. $0.20ms^{-2}$

B. $0.30ms^{-2}$

C. $0.40ms^{-2}$

D. $0.60ms^{-2}$

Answer: d



Watch Video Solution

18. A plank A of mass M rests on a smooth horizontal surface over which it can move without friction. A cube B of mass m lies on the plank at one edge. The coefficient of friction between the plank and the cube is μ . The size of cube is very small in comparison to the

plank.

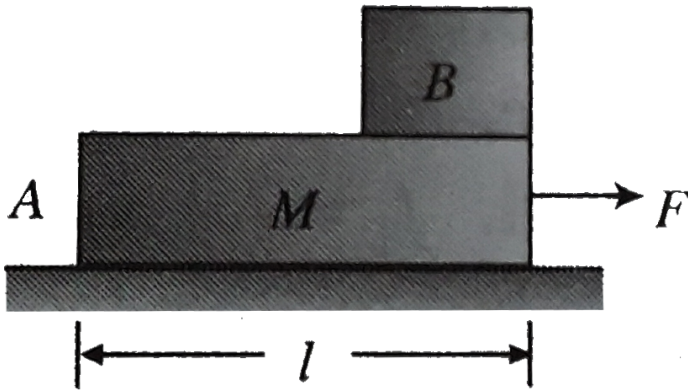

At what force F applied to the plank in the horizontal direction will the cube begin to slide towards the other end of the plank?

- A. $F > \mu(m + M)g$
- B. $F > 0.5\mu(m + M)g$
- C. $F = 0.5\mu(m + M)g$
- D. $F = \mu(m + M)g$

Answer: d



Watch Video Solution

19. A plank A of mass M rests on a smooth horizontal surface over which it can move without friction. A cube B of mass m lies on the plank at one edge. The coefficient of friction between the plank and the cube is μ . The size of cube is very small in comparison to the plank.

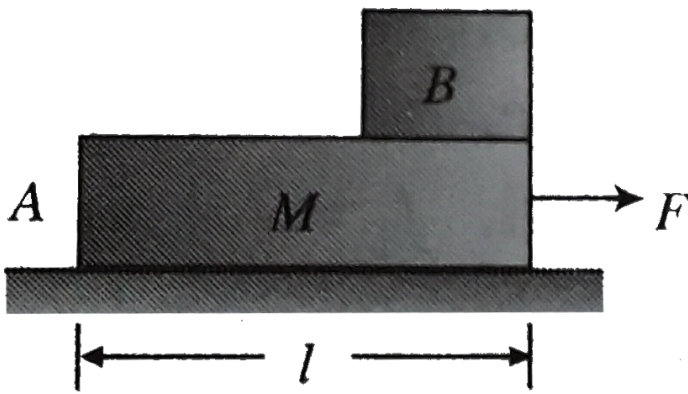

At what force F applied to the plank in the horizontal direction will be cube begin to slide towards the other end of the plank?

- A. $\sqrt{\frac{Ml}{F - \mu g(M + m)}}$
- B. $\sqrt{\frac{2Ml}{F - \mu g(M + m)}}$
- C. $\sqrt{\frac{Ml}{F + \mu g(M + m)}}$
- D. $\sqrt{\frac{Ml}{F + \mu g(M + m)}}$

Answer: b



Watch Video Solution

20. A small block of mass m is placed over a long plank of mass M the coefficient of friction between them is μ . Ground is smooth. At $t = 0$ m is given a velocity v_1 and M a velocity v_2 ($> v_1$) as shown in Fig. After this M is maintained at constant acceleration a ($< \mu g$)

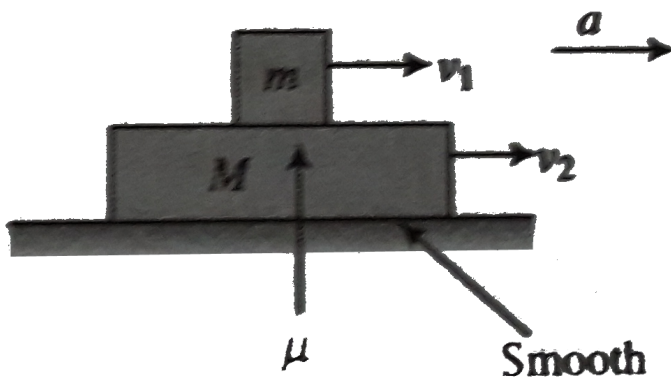

Initially there will be some relative motion between the block and the plank, but after some time relative

motion will cease and velocities of both will become

Find the time t_0 when the velocities of both block and plank become same.

A. $\frac{v_2 - v_1}{\mu g + a}$

B. $\frac{v_2 + v_1}{\mu g - a}$

C. $\frac{v_2 - v_1}{\mu g - a}$

D. $\frac{v_2 + v_1}{\mu g + a}$

Answer: c



Watch Video Solution

21. A small block of mass m is placed over a long plank of mass M the coefficient of friction between them is μ ground is smooth At $t = 0$ m is given a velocity v_1 and M a velocity v_2 ($> v_1$) as shown in figure After this M is maintained at constant acceleration a ($< \mu g$)

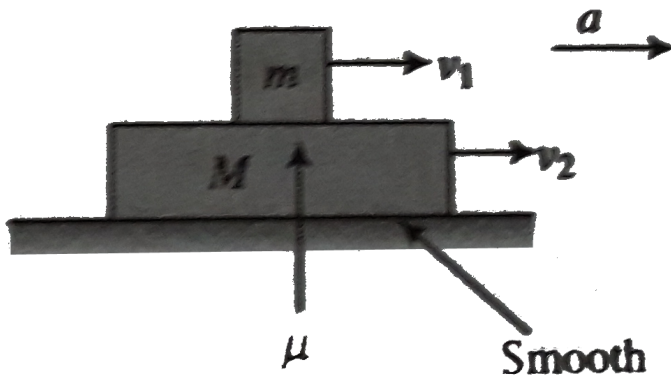

Initially there will be some relative motion between the block and the plank ,but after some time relative motion will cease and velocities of both will become

Draw the velocity of block as a function of time.

time.

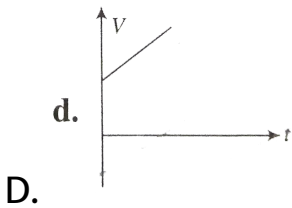
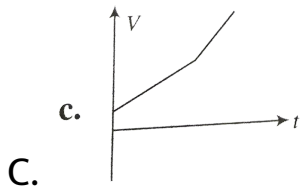
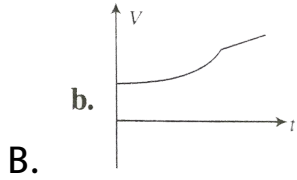
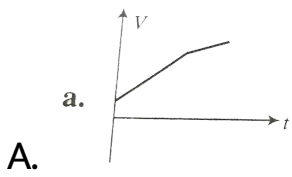

Answer: a



Watch Video Solution

22. A small block of mass m is placed over a long plank of mass M the coefficient of friction between them is μ ground is smooth At $t = 0$ m is given a velocity v_1 and M a velocity v_2 ($> v_1$) as shown in figure After this M is maintained at constant acceleration a ($< \mu g$)

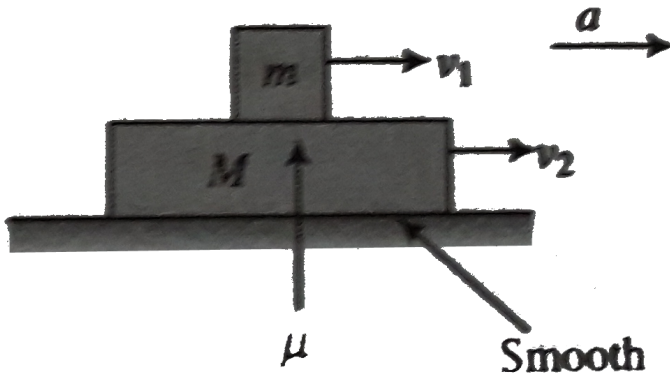

Initially there will be some relative motion between the block and the plank ,but after some time relative motion will cease and velocities of both will become

Find the forward force acting on the plank before after t_0 respectively.

A. $Ma, (M + m)a$

B. $\mu mg + Ma, (M + m)a$

C. $\mu Mg + ma + Ma$

D. $(M + m)a, \mu mg + Ma$

Answer: b



Watch Video Solution

23. A block of mass $4kg$ pressed against a rough wall by two perpendicular horizontal forces F_1 and F_2 as

shown in figure Coefficient of static friction between the block and wall is 0.6 and that of kinetic friction is 0.5

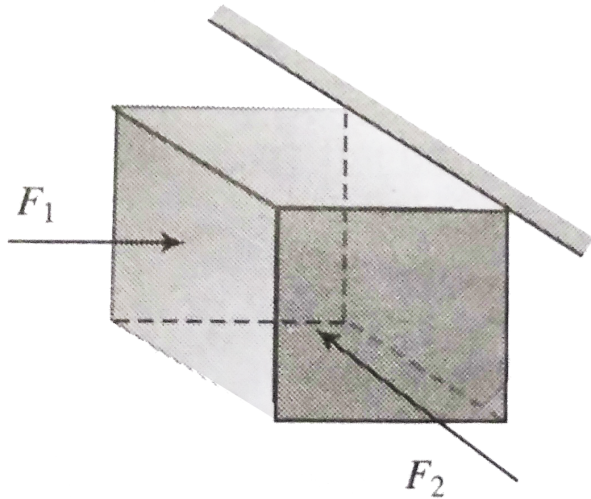

For $F_1 = 300N$ and $F_2 = 100N$ find the direction and magnitude of friction force acting on the block

- A. $180N$ vertically upward
- B. $40N$ vertically upward

C. $107.7N$ making an angle of $\tan^{-1}\left(\frac{2}{5}\right)$ will the horizontal the upward direction

D. $91.6N$ making an angle of $\tan^{-1}\left(\frac{2}{5}\right)$ will the horizontal the upward direction

Answer: c

 [Watch Video Solution](#)

24. A block of mass $4kg$ pressed against a rough wall by two perpendicular horizontal forces $F_1 = 300N$ and $F_2 = 100N$ as shown in figure Coefficient of static friction between the block and wall is 0.6 and that of kinetic friction is 0.5

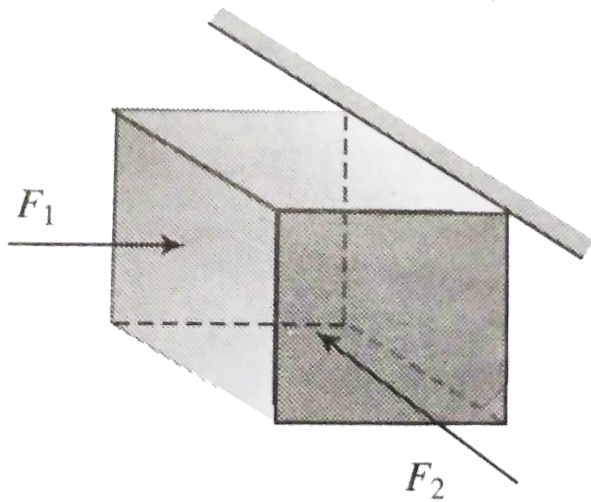

For the above data, what is the acceleration of block?

A. Zero

B. $\frac{140}{4}ms^{-2}$,upward

C. $\frac{180}{4}ms^{-2}$,upward

D. $\frac{107.7}{4}ms^{-2}$ at an $\tan^{-1}\left(\frac{2}{5}\right)$ with the

horizontal in the upward direction

Answer: a



Watch Video Solution

25. A block of mass $4kg$ pressed against a rough wall by two perpendicular horizontal forces F_1 and F_2 as shown in figure Coefficient of static friction between the block and wall is 0.6 and that of kinetic friction is 0.5

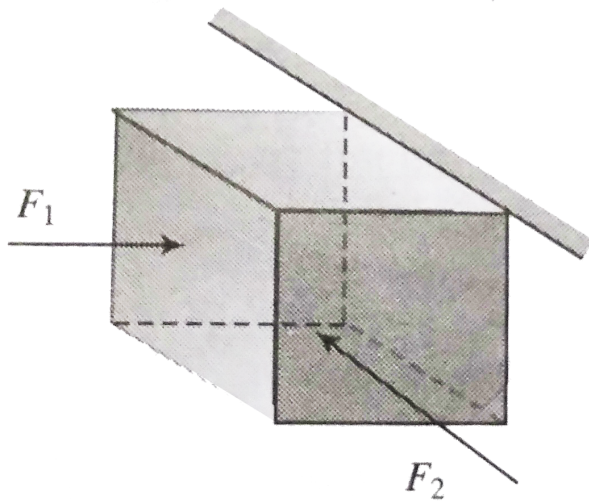

For $F_1 = 150N$ and $F_2 = 100N$ find the direction and magnitude of friction acting on the block

A. $90N$ making an angle of $\tan^{-1}\left(\frac{2}{5}\right)$ with the

horizontal in the upward direction

B. $75N$ making an angle of $\tan^{-1}\left(\frac{2}{5}\right)$ with the

horizontal in the upward direction

C. $107.7N$ making an angle of $\tan^{-1}\left(\frac{2}{5}\right)$ with the

horizontal in the upward direction

D. Zero

Answer: b



Watch Video Solution

26. A block of mass 4kg pressed against a rough wall by two perpendicular horizontal forces F_1 and F_2 as shown in figure. Coefficient of static friction between the block and wall is 0.6 and that of kinetic friction is 0.5

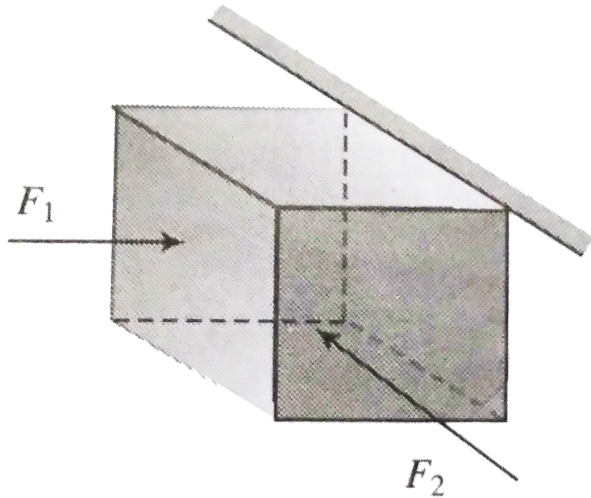

For the data of Q 28 ,Find the magnitude of acceleration of the block

A. Zero

B. $22.5ms^{-2}$

C. $26.925ms^{-2}$

D. $9.175ms^{-2}$

Answer: d



Watch Video Solution

27. A system of two blocks and a light string are kept on two inclined faces (rough) as shown in figure. All the required data is mentioned in the diagram pulley is light and frictionless

$(Take g = 10ms^{-2}, \sin 37^\circ = 3/5)$

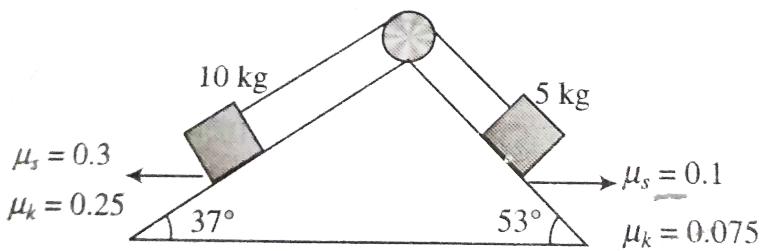

If the system is released from rest , then the acceleration of the system is

- A. $\frac{7}{15}ms^{-2}$
- B. Zero
- C. $\frac{47}{15}ms^{-2}$
- D. $\frac{2.25}{15}ms^{-2}$

Answer: b

[Watch Video Solution](#)

28. A system of two blocks and a light string are kept on two inclined faces (rough) as shown in figure. All the required data is mentioned in the diagram pulley is light and frictionless

(Take $g = 10\text{ms}^{-2}$, $\sin 37^\circ = 3/5$)

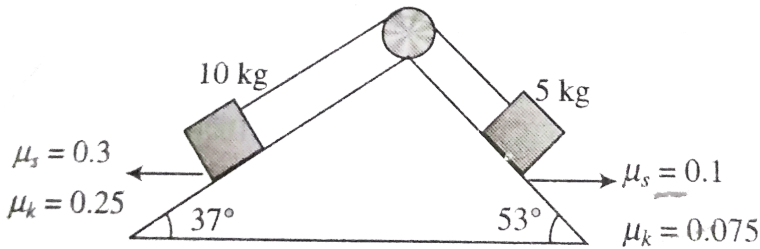

If the system is released from rest , then the acceleration of the system is

A. $13.33s$

B. $80s$

C. Infinite

D. Question is irrelevant

Answer: a

 [Watch Video Solution](#)

29. A system of two blocks and a light string are kept on two inclined faces (rough) as shown in figure. All the required data is mentioned in the diagram pulley is light and frictionless

(Take $g = 10\text{ms}^{-2}$, $\sin 37^\circ = 3/5$)

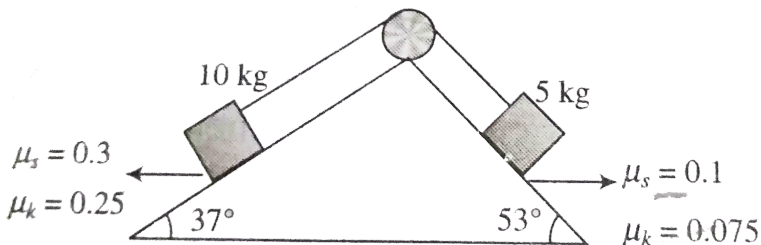

If the system is released from rest , then the acceleration of the system is

- A. The system first decelerates, comes to a stop, and then continues to move in the opposite direction
- B. The system will continuously move with constant speed
- C. The system first decelerates and then come to a stop
- D. The system acceleration and its speed increases with time

Answer: c



Watch Video Solution

30. A system of two blocks is placed on a rough horizontal surface as shown in figure below. The coefficient of static and kinetic friction at two surfaces are shown. A force F is horizontally applied on the upper block as shown. Let f_1, f_2 represent the frictional force between upper and lower surface of contact respectively and a_1, a_2 represent the acceleration of 3kg and 2kg block respectively.

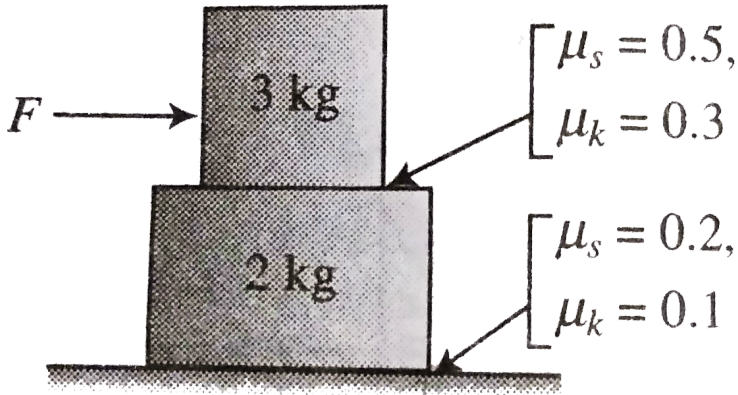

For $F = 12N$ mark the correct option

- A. For a particular value of $F (< F_0)$ there is no motion at any of the contact surface
- B. The value of F_0 is $10N$
- C. The F increases beyond F_0 , f_1 increases and continues to increase until it reaches its limiting value
- D. All of the above

Answer: d



Watch Video Solution

31. A system of two blocks is placed on a rough horizontal surface as shown in figure below. The coefficient of static and kinetic friction at two surfaces are shown. A force F is horizontally applied on the upper block as shown. Let f_1, f_2 represent the frictional force between upper and lower surface of contact respectively and a_1, a_2 represent the acceleration of 3kg and 2kg block respectively.

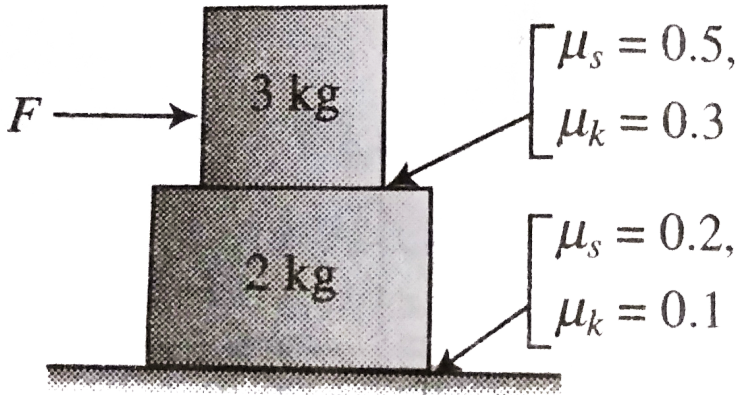

For $F = 12N$ mark the correct option

A.

$$f_1 = 7.8N, f_2 = 7.8N, a_1 = 1.4ms^{-2}, a_2 = 0ms^{-2}$$

B. $f_1 = 7.8N, f_2 = 10N, a_1 = a_2 = 1.4ms^{-2}, a_2$

C. $f_1 = 7.8N, f_2 = 5N, a_1 = a_2 = 1.4ms^{-2}$

D. $f_1 = 7.4N, f_2 = 5N, a_1 = a_2 = 1.2ms^{-2}$

Answer: c



32. A system of two blocks is placed on a rough horizontal surface as shown in figure below. The coefficient of static and kinetic friction at two surfaces are shown. A force F is horizontal applied on the upper block as shown. Let f_1, f_2 represent the frictional force between upper and lower surface of contact respectively and a_1, a_2 represent the acceleration of 3kg and 2kg block respectively.

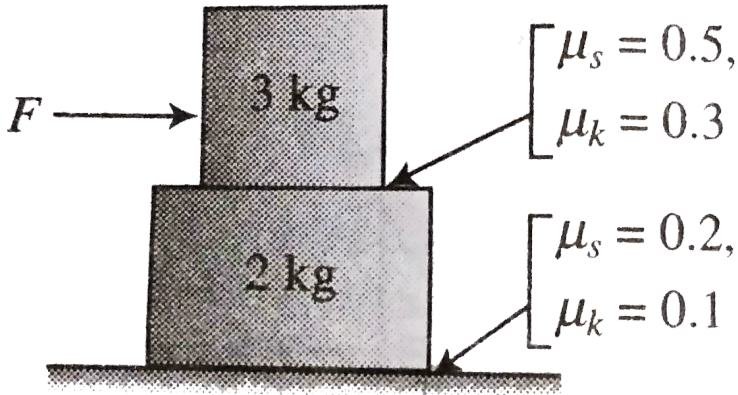

For relative motion to be there between two blocks the minimum value of F should be

- A. $15N$
- B. $30N$
- C. $25N$
- D. $32N$

Answer: b



33. Two bodies A and B of masses 10kg and 5kg placed very slightly separated as shown in figure. The coefficient of friction between the floor and the blocks are as $\mu_s = 0.4$. Block A is pushed by an external force F . The value of F can be changed when the weight between block A and ground breaks, block A will start pressing block B, which will start pressing the vertical wall.

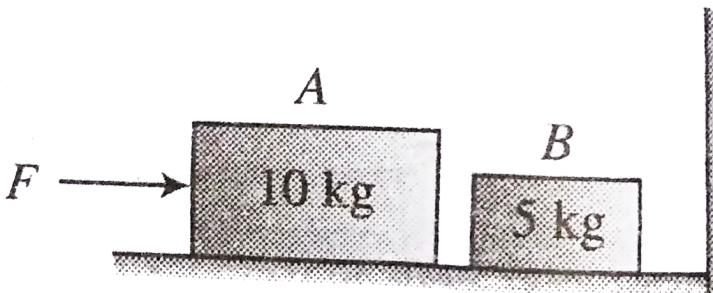

If $F = 20\text{N}$, with how much force does block A press block B?

A. $10N$

B. $20N$

C. $30N$

D. Zero

Answer: d



Watch Video Solution

34. Two bodies A and B of masses $10kg$ and $5kg$ placed very slightly separated as shown in figure. The coefficient of friction between the floor and the block are as $\mu_s = 0.4$. Block A is pushed by an external force F . The value of F can be changed when the weight

between block A and ground breaks block A will start

pressing block B will start pressing the vertical wall

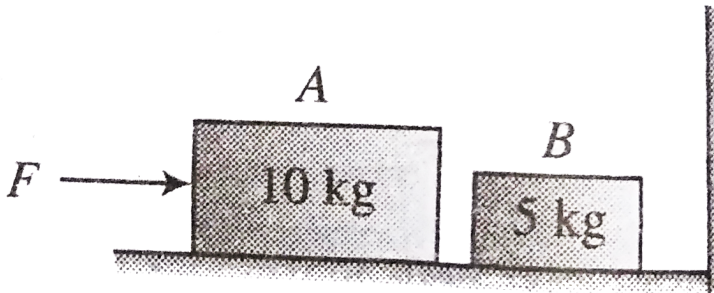

If $F = 50N$ the friction force acting between block B and ground will be

A. $10N$

B. $20N$

C. $30N$

D. None

Answer: a



Watch Video Solution

35. Two bodies A and B of masses 10kg and 5kg placed very slightly separated as shown in figure. The coefficient of friction between the floor and the blocks are as $\mu_s = 0.4$. Block A is pushed by an external force F . The value of F can be changed when the weight between block A and ground breaks, block A will start pressing block B, which will start pressing the vertical wall.

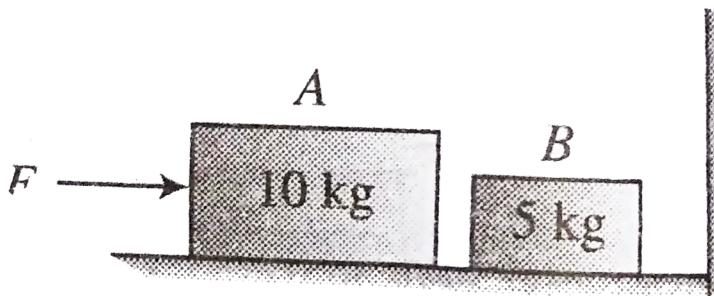

The force of friction acting on B verius with the applied force F acceleration to curve

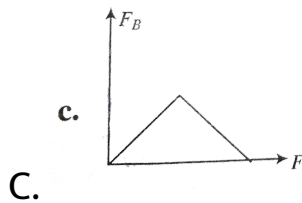
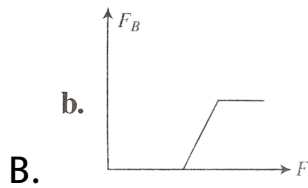
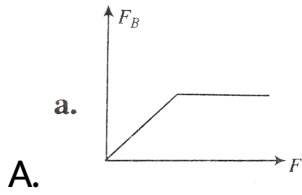

D. 

Answer: b



Watch Video Solution

36. On a stationary block of mass 2kg a horizontal forces F starts acting at $t = 0$ whose variation with time is shown in figure .The coefficient of friction between the block and ground is 0.5 New answer the following question

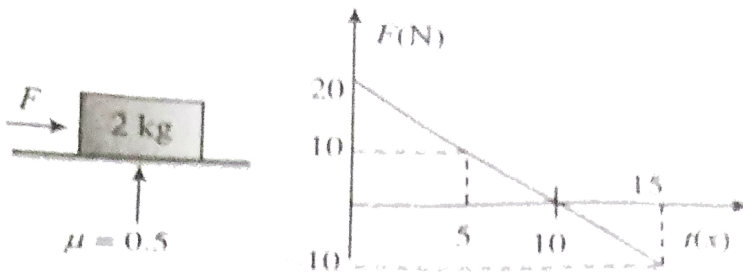

Find the time when acceleration of the block is zero

- A. At 5s only
- B. At 10s only
- C. Both at 5s and 10s

D. At a time after $t = 5$ only

Answer: c

 [Watch Video Solution](#)

37. On a stationary block of mass 2 kg a horizontal force F starts acting at $t = 0$ whose variation with time is shown in figure. The coefficient of friction between the block and ground is 0.5 . Answer the following question

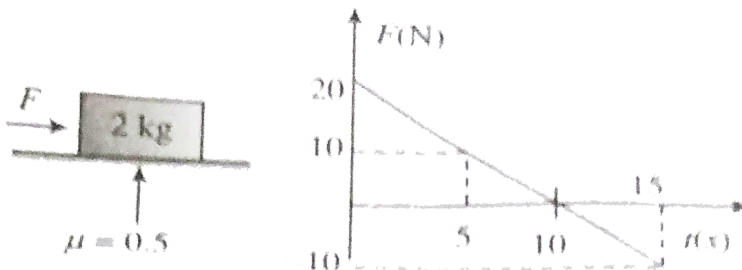

Find the velocity of the block when for the first time its acceleration become zero

A. 12.5ms^{-1}

B. 25ms^{-1}

C. 10ms^{-1}

D. None of these

Answer: a



Watch Video Solution

38. On a stationary block of mass 2kg a horizontal forces F starts acting at $t = 0$ whose variation with

time is shown in figure .The coefficient of friction between the block and ground is 0.5 New answer the following question

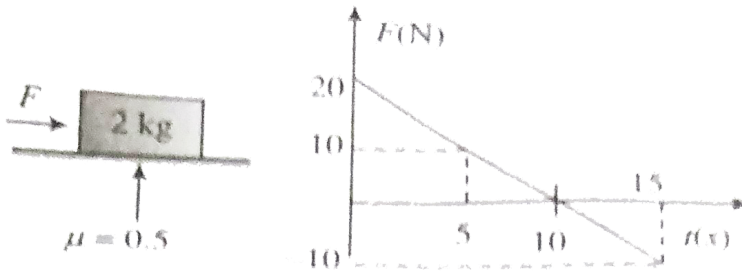

Find the velocity of the at $t = 12s$

- A. $20ms^{-1}$
- B. $-12ms^{-1}$
- C. $+6ms^{-1}$
- D. Zero

Answer: d

39. A long conveyer belt moves with a constant velocity of 8 m s^{-1} . Two blocks A and B each of mass 2 kg are placed gently on the belt with B on A, initial velocity of block is zero. Coefficient of friction between A and belt is 0.1. There is no friction between A and B. Length of A is 4 m .

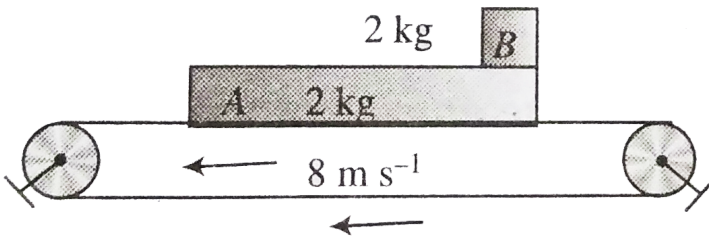

Find the time when A falls off. Initially, B is on the right end of A. Ignore the dimensions of B.

A. $1s$

B. $3s$

C. $2s$

D. $4s$

Answer: c



Watch Video Solution

40. A long conveyer belt moves with a constant velocity of $8ms^{-1}$. Two block A and B each of mass $2kg$ are placed gently on the belt with B on A, initial velocity of block is zero Coefficient of friction between A and belt is 0.1 There is no friction between A and B length of A is

4m

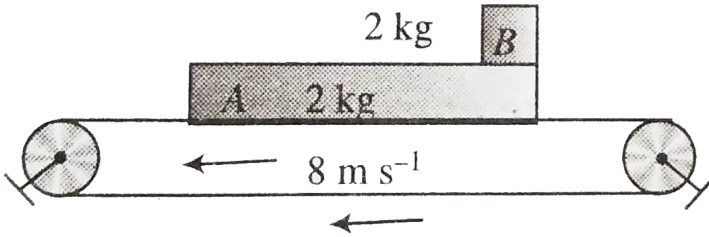

Find the velocity of A when B falls off A

A. 2 m s^{-1}

B. 4 m s^{-1}

C. 6 m s^{-1}

D. 8 m s^{-1}

Answer: b



Watch Video Solution

41. A long conveyer belt moves with a constant velocity of 8 m s^{-1} . Two blocks A and B each of mass 2 kg are placed gently on the belt with B on A, initial velocity of block is zero. Coefficient of friction between A and belt is 0.1. There is no friction between A and B. Length of A is 4 m .

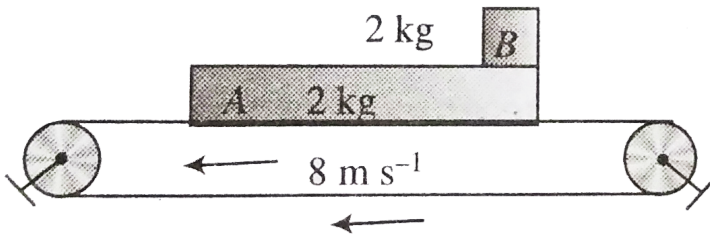

Find the velocity of A when B falls off A

A. 8 m

B. 6 m

C. 2 m

D. None of these

Answer: c



Watch Video Solution

42. Two smooth blocks of masses m and m' connected by a light inextensible strings are moving on a smooth wedge of mass M . If a force F acts on the wedge the blocks do not slide relative to the wedge. Find the (a)

acceleration of the wedge and (b) value of F .

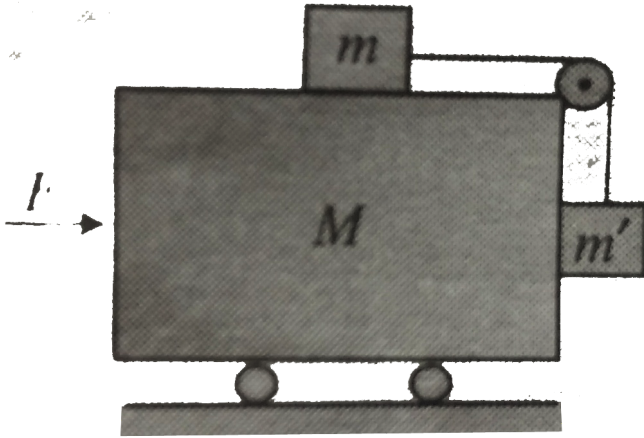

- A. $\frac{m'}{m + M}g$
- B. $\frac{m'}{m}g$
- C. $\frac{m'}{M}g$
- D. $\frac{m}{m'}g$

Answer: b



Watch Video Solution

43. Two smooth blocks of masses m and m' connected by a light inextensible strings are moving on a smooth wedge of mass M . If a force F acts on the wedge the blocks do not slide relative to the wedge. Find the (a) acceleration of the wedge and (b) value of F .

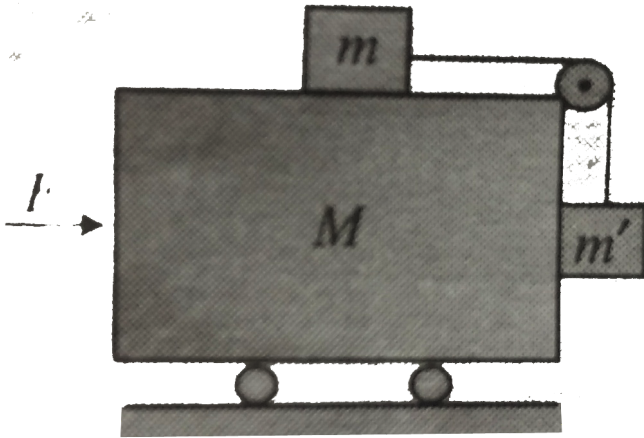

A. $(M + m + m') \frac{m'}{m} g$

B. $(M + m + m') \frac{m'}{m + M} g$

C. $(M + m + m') \frac{m'}{m' + M} g$

$$D. (M + m + m') \frac{M}{m' + M} g$$

Answer: a



Watch Video Solution

44. A person of mass 75kg works in a where his job is to arrange heavy articles in a stone - room As shown in figure he place a packing of mass 20kg on a ramp that is inclined to the horizontal at 37° and pushed it up the ramp with an acceleration 1.5ms^{-2} . This is the minimum acceleration for the packege to reach the top to the ramp. The coefficient of static and friction between the shoes of the person and the ground is 0.8 and coefficient of kinetic friction for the motion of

package on the is 0.5

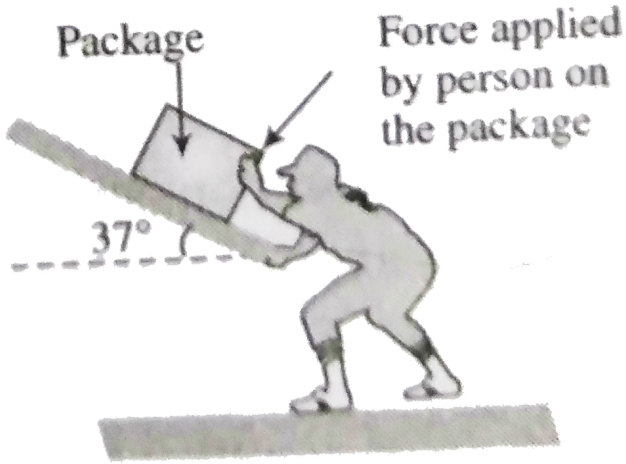

Force applied by the person on the package is

A. $120N$

B. $250N$

C. $210N$

D. None of these

Answer: d



Watch Video Solution

45. A person of mass 75kg works in a where his job is to arrange heavy articles in a stone - room As shown in figure he place a packing of mass 20kg on a ramp that is inclined to the horizontal at 37° and pushed it up the ramp with an acceleration 1.5ms^{-2} .This is the minimum acceleration for the packege to reach the top to the ramp.The coefficient of static and friction between the shoes of the person and the ground is 0.8 and coefficient of kinetic friction for the motion of package on the is 0.5

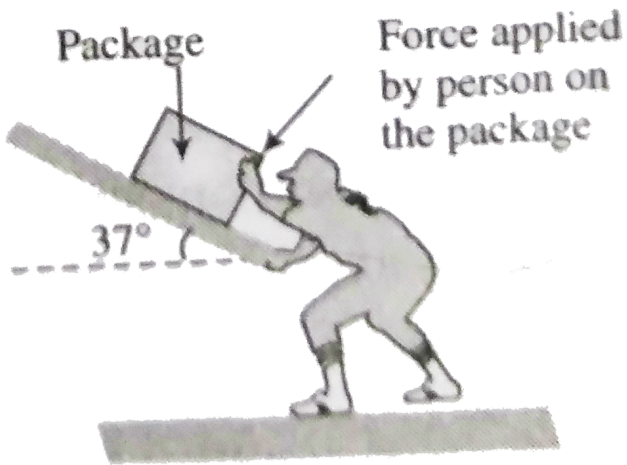

Force applied by the person on the package is

A. $168N$

B. $200N$

C. $480N$

D. None of these

Answer: d



Watch Video Solution

46. A person of mass 75kg works in a warehouse where his job is to arrange heavy articles in a store room. As shown in figure he places a packing of mass 20kg on a ramp that is inclined to the horizontal at 37° and pushes it up the ramp with an acceleration 1.5ms^{-2} . This is the minimum acceleration for the package to reach the top of the ramp. The coefficient of static friction between the shoes of the person and the ground is 0.8 and coefficient of kinetic friction for the motion of package on the ramp is 0.5 .

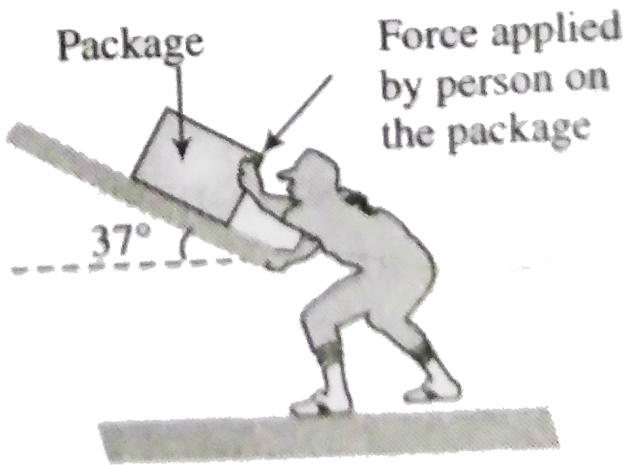

Force applied by the person on the package is

- A. $120N$
- B. $250N$
- C. $210N$
- D. None of these

Answer: d

 **Watch Video Solution**

47. A person of mass 75kg works in a warehouse where his job is to arrange heavy articles in a store - room. As shown in figure he places a packing of mass 20kg on a ramp that is inclined to the horizontal at 37° and pushes it up the ramp with an acceleration 1.5ms^{-2} . This is the minimum acceleration for the package to reach the top of the ramp. The coefficient of static friction between the shoes of the person and the ground is 0.8 and coefficient of kinetic friction for the motion of package on the ramp is 0.5 .

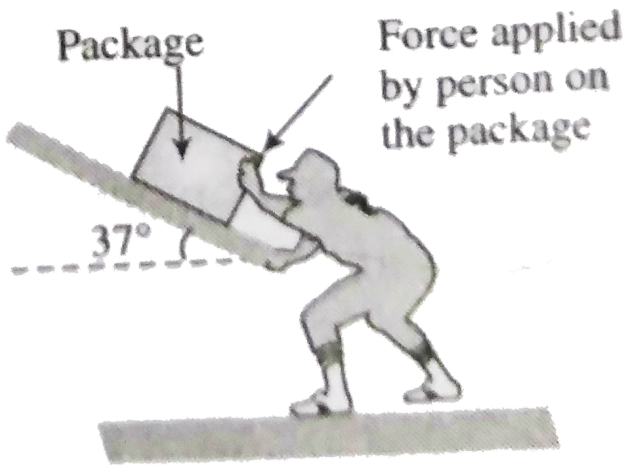

Force applied by the person on the package is

- A. $160N$
- B. $200N$
- C. $180N$
- D. None of these

Answer: d

 **Watch Video Solution**

48. figure depicts a block sliding along a frictionless ramp in vertical plane Eight numbered arrows in the diagram represent direction to be referred to when answering the questions

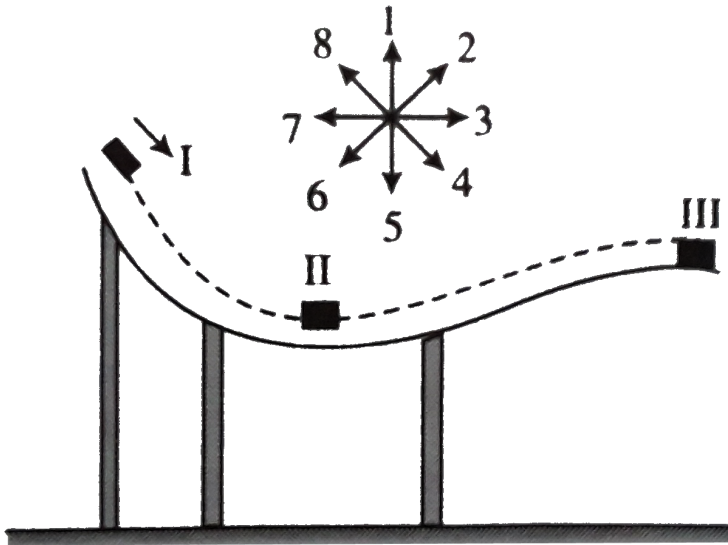

Position - i : Starts sliding on curve path

Position - ii : Lowest position of the curve path

Position - iii : Just outside of the curve path

The direction of the acceleration of the blocks when in position ii is best represented by which of the arrows in the diagram?

A. 4

B. 5

C. 2

D. None of the arrows, the acceleration is zero

Answer: a



Watch Video Solution

49. figure depicts a block sliding along a frictionless ramp in vertical plane Eight numbered arrows in the diagram represent direction to be referred to when answering the questions

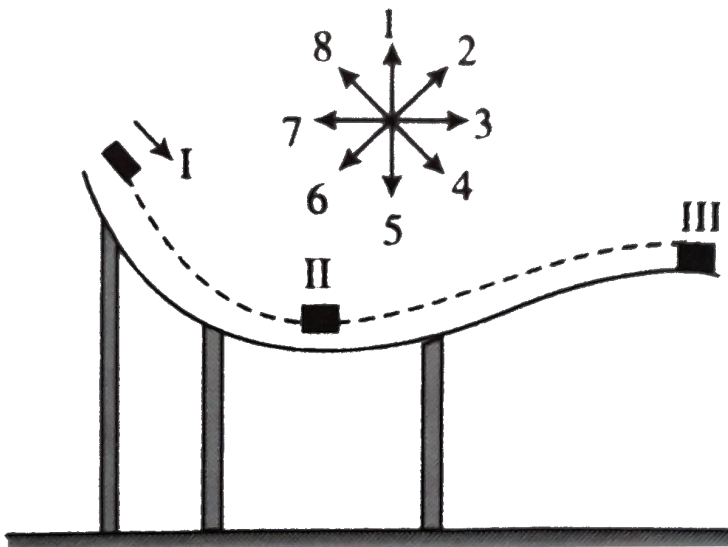

Position - i : Starts sliding on curve path

Position - ii : Lowest position of the curve path

Position - iii : Just outside of the curve path

The direction of the acceleration of the blocks when in

position ii is best represented by which of the arrows in the diagram?

A. 5

B. 8

C. 1

D. 3

Answer: c



Watch Video Solution

50. figure depicts a block sliding along a frictionless ramp in vertical plane Eight numbered arrows in the

diagram represent direction to be referred to when answering the questions

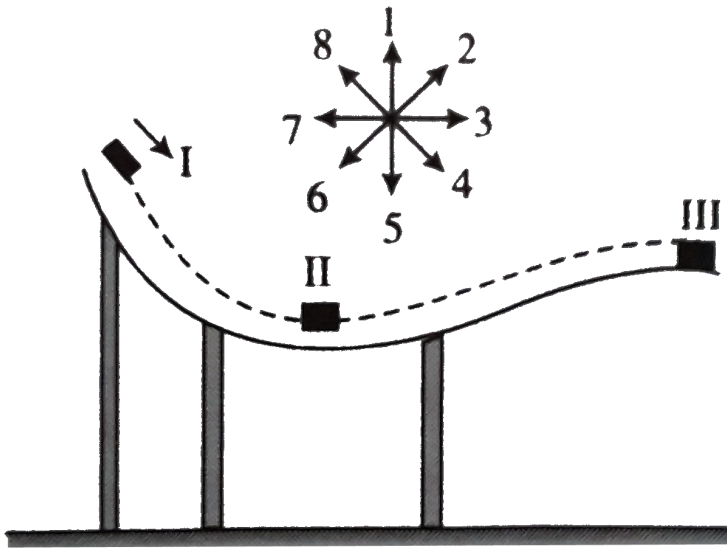

Position - i : Starts sliding on curve path

Position - ii : Lowest position of the curve path

Position - iii : Just outside of the curve path

The direction of the acceleration of the blocks (after leaving the ramp) at position i is best represented by which of the arrows in the diagram?

A. 5

B. 6

C. 2

D. None of the arrows, the acceleration is zero

Answer: a



Watch Video Solution

51. The coin is rotating with a plate without sliding. If the coefficient of friction between the coin and plane is $\mu = 0.75$ the friction between the coin and plate is

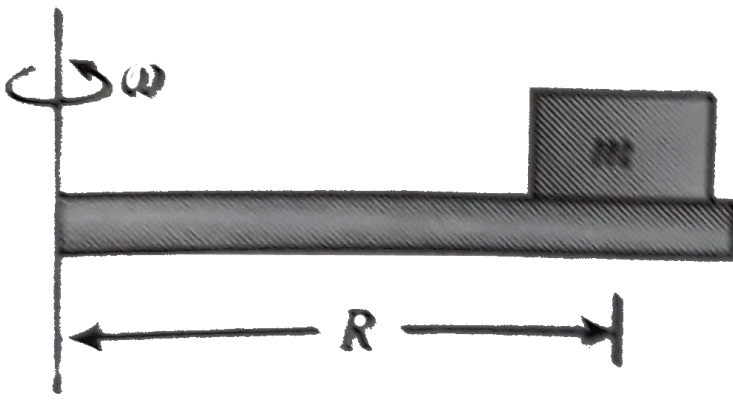

If the angular frequency of the rotation of the plate is

$\omega = \sqrt{\frac{g}{2R}}$ the friction force acting on coin is

A. $\frac{3}{4}mg \rightarrow$

B. $\frac{mg}{4} \leftarrow$

C. $\frac{mg}{2} \leftarrow$

D. $\frac{mg}{2} \rightarrow$

Answer: c

 **Watch Video Solution**

52. The coin is rotating with a plate without sliding. If the coefficient of friction between the coin and plane is $\mu = 0.75$ the friction between the coin and plate is



If the plate is rotating along and the coin is gently placed on the rotating plate, the frictional force on the coin is



[Watch Video Solution](#)

Integer

1. Block B of mass $m_B = 0.5\text{kg}$ rests on block A, with mass $m_A = 1.5\text{kg}$ which in turn is on a horizontal tabletop (as shown in figure). The coefficient of kinetic friction between block A and the tabletop is $\mu_k = 0.4$ and the coefficient of static friction between block A and block B is $\mu_s = 0.6$. A light string attached to block A passes over a frictionless, massless pulley and block C is suspended from the other end of the string. What is the largest mass m_c (in kg) that block C can have so that block A and B still slide together when the system

is relaxed from rest?

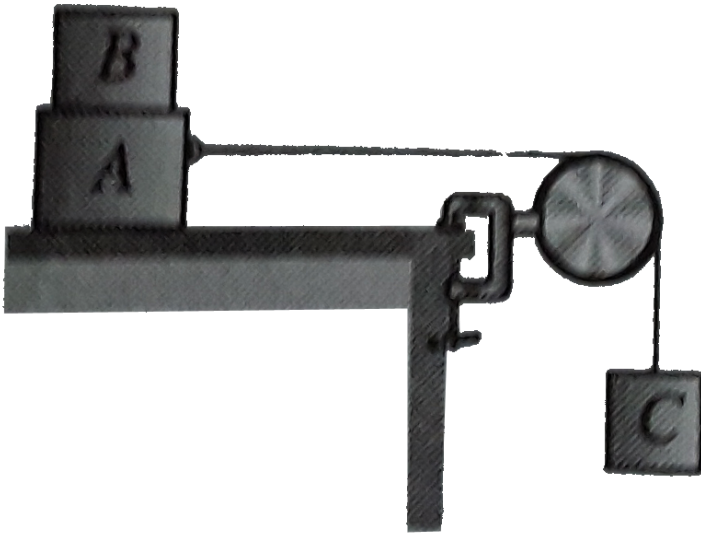

Watch Video Solution

2. A block of mass $m = 2\text{kg}$ is resting on a inclined plane of inclination 30° as shown in figure The coefficient of friction between the block and the plane is $\mu = 0.5$ what minimum force F (in newton) should be applied perpendicular to the plane on the block so that

the does not slip on the plane?

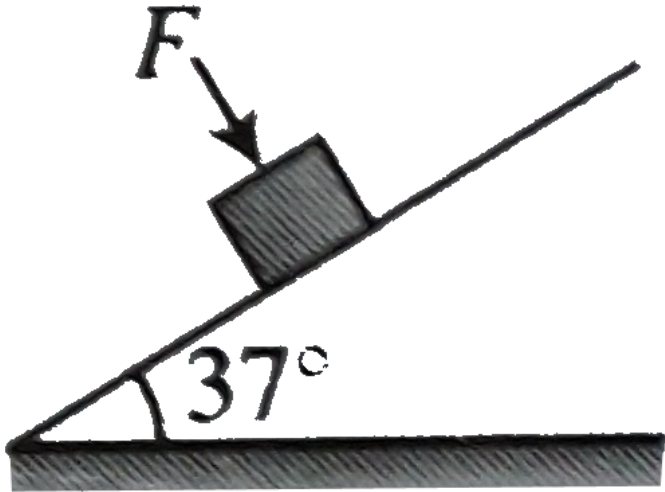

[Watch Video Solution](#)

3. A block A of mass m is placed over a plank B of mass $2m$. Plank B is placed over a smooth horizontal surface. The coefficient of friction between A and B is 0.4 . Block A is given a velocity v_0 toward right. Find acceleration

(in ms^{-2} of B relative to A)

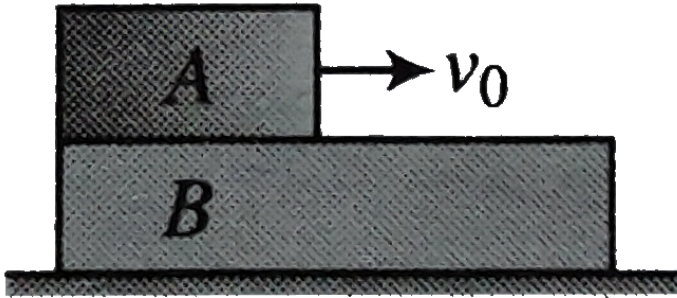

[▶ Watch Video Solution](#)

4. A rod AB of length $2m$ is hinging at point A and its other end B is attached to a platform on which a point of mass m is kept. Rod rotates about point A maintaining angle $\theta = 30^\circ$ with the vertical in such a way that platform remain horizontal and revolves on the horizontal circular path. If the coefficient of static friction

between the block and platform is $\mu = 0.1$ then find the maximum angular velocity in rad s^{-1} of rod so that the block does not slip on the platform ($g = 10\text{m s}^{-2}$)

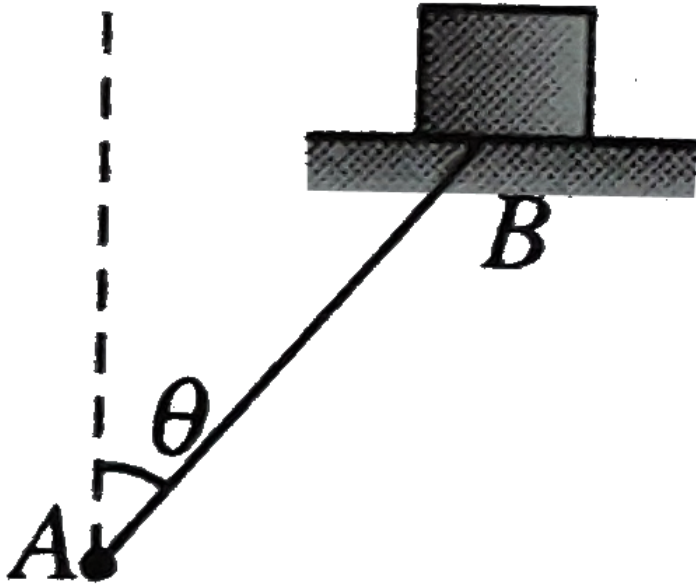

[Watch Video Solution](#)

5. A block A of weight W slide down an inclined plane S of slope 37° at a contact velocity, while the plane B also of weight W rests on top of A. The plank B is attached by a cord to the top of plane. The coefficient of kinetic friction μ is the same between the surface A and B and between S and A. Determine the value of $1/\mu$

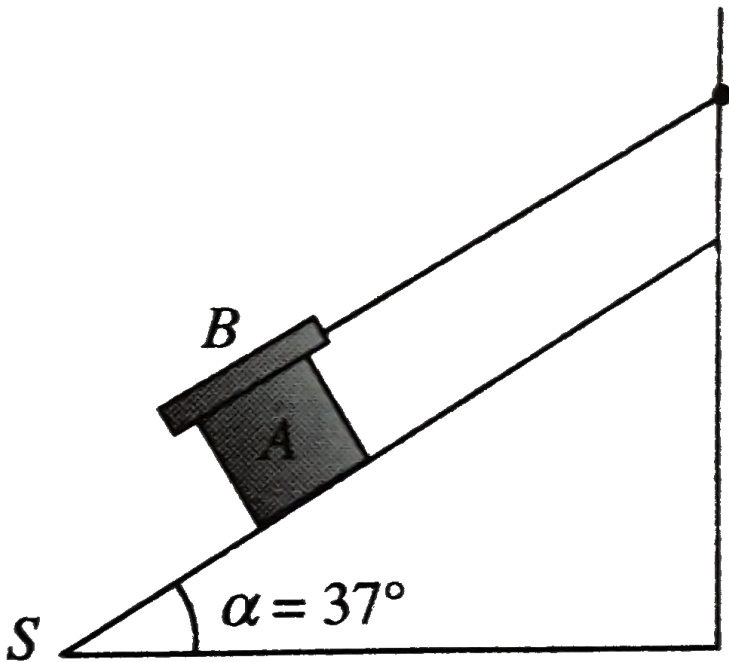

Watch Video Solution

6. A block of mass m kg lies on a horizontal surface in a truck. The coefficient of static friction between the block and the surface is 0.6. If the acceleration of the truck is 5 m s^{-2} . The frictional force acting on the block is



[Watch Video Solution](#)

True And False

1. "When a person walks on a rough surface the frictional force exerted by the surface on the person is

opposite to the direction of his motion". Is it true or false ?



[Watch Video Solution](#)

2. A simple pendulum with a bob of mass m swings with an angular amplitude of 40° . When its angular displacement is 20° , the tension in the string is greater than $mg\cos 20^\circ$



[Watch Video Solution](#)

3. The pulley arrangement in Fig are identical .The mass of the rope is negligible in figure the mass m is lifted up

by attached a mass $2m$ to the other end of the rope . In

(b), m is lifed up by pulley the other end of the rope

with a constant in both cases



(a)

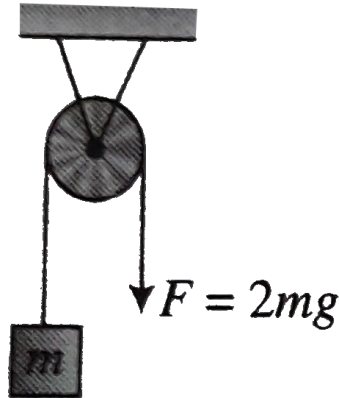

(b)

[Watch Video Solution](#)

4. In the arrangement shown in figure, the ends P and Q of an unstretchable string move downwards with uniform speed U . Pulleys A and B are fixed. Mass M

moves upwards with a speed

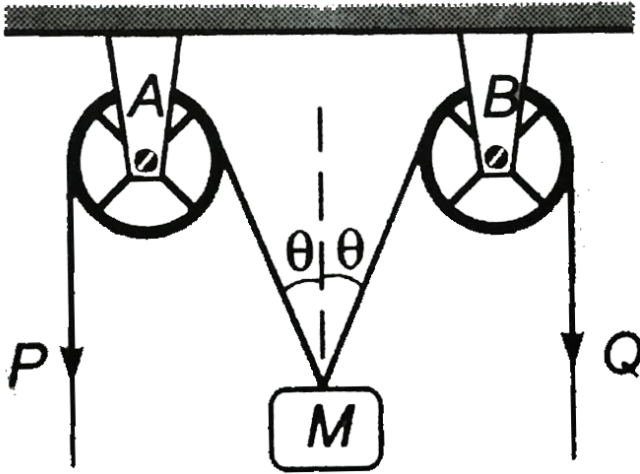

- (a) $2U \cos \theta$ (b) $\frac{U}{\cos \theta}$ (c) $\frac{2U}{\cos \theta}$ (d) $U \cos \theta$

 [Watch Video Solution](#)

Single correct answer type

1. A ship of mass $3 \times 10^7 \text{ kg}$ initially at rest, is pulled by a force of $5 \times 10^5 \text{ N}$ through a distance of 3m. Assuming that the resistance due to water is negligible, the speed of the ship is

A. 1.5 m s^{-1}

B. 60 m s^{-1}

C. 0.1 m s^{-1}

D. 5 m s^{-1}

Answer: c



Watch Video Solution

2. A block of mass 2 kg rest on a plane inclined al an angle pf 30° with the horizontal. The coefficient of friction between the block and the surface is 0.7. what will be the frictional force acting on the block?

A. $9.8N$

B. $0.7 \times 9.8 \times (\sqrt{3})N$

C. $9.8 \times (\sqrt{3})N$

D. $0.7 \times 9.8N$

Answer: a



Watch Video Solution

3. When a bicycle is in motion, the force of friction exerted by the ground on the two wheels is such that it acts

A. In the backward on the front wheel and in the forward on the rear wheel

B. In the forward direction on the front wheel and in the backward on the rear wheel

C. In the backward direction on both and the rear wheel

D. In the forward direction on both the front and the rear wheel

Answer: a



Watch Video Solution

4. A car is moving in a circular horizontal track of radius 10 m with a constant speed of 10m s^{-1} . A plumb bob is suspended from the roof of the car by a light rigid rod of length 1 m. The angle made by the rod with track is

A. Zero

B. 30°

C. 45°

D. 60°

Answer: c



Watch Video Solution

5. A block of mass 0.1 kg is held against a wall applying a horizontal force of 5 N on the block. If the coefficient of friction between the block and the wall is 0.5 , the magnitude of the frictional force acting on the block is :

A. 2.5 N

B. 0.98 N

C. 4.9 N

D. 0.49 N

Answer: b



Watch Video Solution

6. An insect crawls up a hemispherical surface very slowly (see fig.). The coefficient of friction between the insect and the surface is $1/3$. If the line joining the center of the hemispherical surface to the insect makes an angle α with the vertical, the maximum possible

value of α is given by

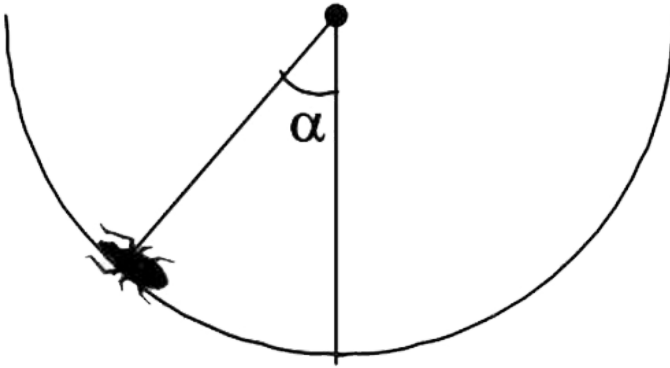

A. $\cot \alpha = 3$

B. $\tan \alpha = 3$

C. $\sec \alpha = 3$

D. $\operatorname{cosec} \alpha = 3$

Answer: a



Watch Video Solution

7. The pulleys and strings shown in the figure are smooth and of negligible mass. For the system to remain in equilibrium, the angle θ should be

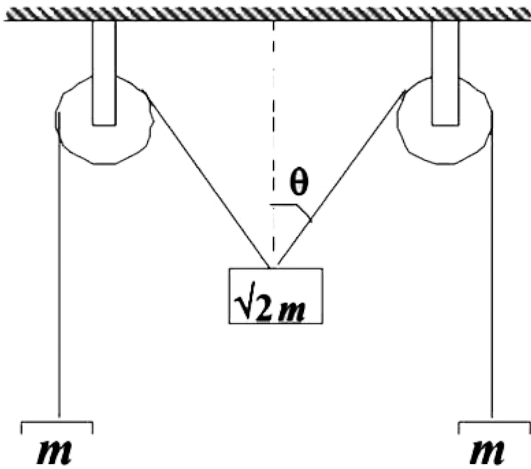

- A. 0°
- B. 30°
- C. 45°
- D. 60°

Answer: c



Watch Video Solution

8. A string of negligible mass going over a clamped pulley of mass m supports a block of mass M as shown in the figure. The force on the pulley by the clamp is

given by

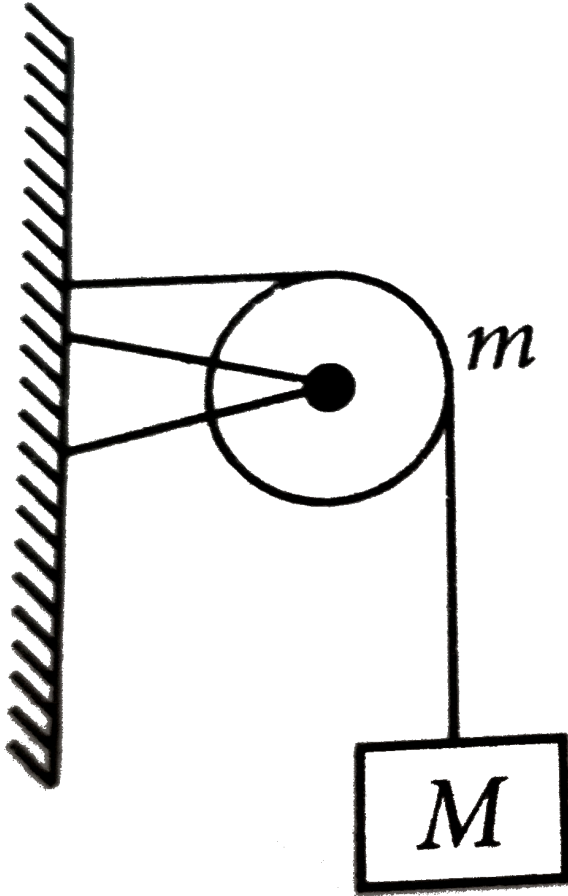

A. $\sqrt{2}Mg$

B. $\sqrt{2}mg$

C. $\left(\sqrt{(M+m)^2 + m^2}\right)g$

D. $\left(\sqrt{(M + m)^2 + M^2}\right)g$

Answer: d

 Watch Video Solution

9. What is the maximum value of the force F such that the block shown in the arrangement, does not move?

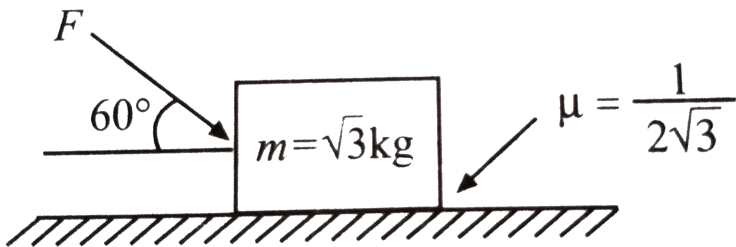

A. $20N$

B. $10N$

C. $12N$

D. $15N$

Answer: a

 [Watch Video Solution](#)

10. Two masses each equal to m are lying on x -axis at $(-a, 0)$ $(+a, 0)$ respectively as shown in figure They are connected by a light string A force F is applied at the origin along vertical direction As a result the masses move toward each other without losing contact with ground What is the acceleration of each mass? Assume the instantaneous position of the

masses as $(-x, 0)$ and $(x, 0)$

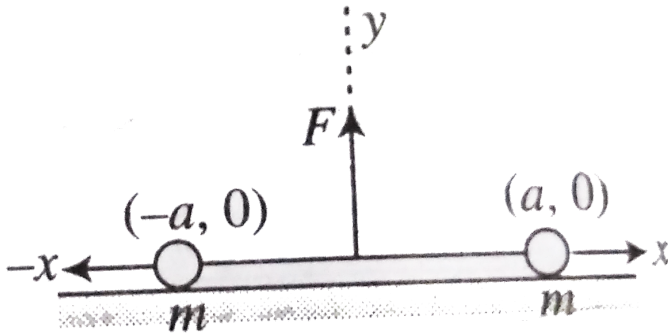

A. a. $\frac{2F}{m} \sqrt{\frac{a^2 - x^2}{x}}$

B. b. $\frac{2F}{m} \cdot \frac{x}{\sqrt{a^2 - x^2}}$

C. c. $\frac{F}{2m} \cdot \frac{x}{\sqrt{a^2 - x^2}}$

D. d. $\frac{F}{m} \frac{x}{\sqrt{a^2 - x^2}}$

Answer: c



Watch Video Solution

11. A block of mass m is on an inclined plane of angle θ . The coefficient of friction between the block and the plane is μ and $\tan \theta > \mu$. The block is held stationary by applying a force P parallel to the plane. The direction of force pointing up the plane is taken to be positive. As P is varied from $P_1 = mg(\sin \theta - \mu \cos \theta)$ to $P_2 = mg(\sin \theta + \mu \cos \theta)$, the frictional force f versus P graph will look like

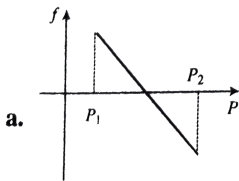

A.

B. 

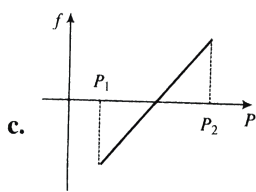

C.

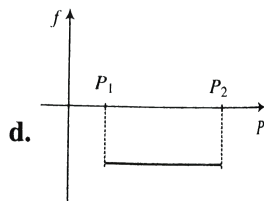

D.

Answer: a



Watch Video Solution

12. A ball of mass (m) 0.5 kg is attached to the end of a string having length (L) 0.5m. The ball is rotated on a horizontal circular path about vertical axis. The maximum tension that the string can bear is 324 N. Find the maximum possible value of angular velocity of

ball (in rads^{-1}).

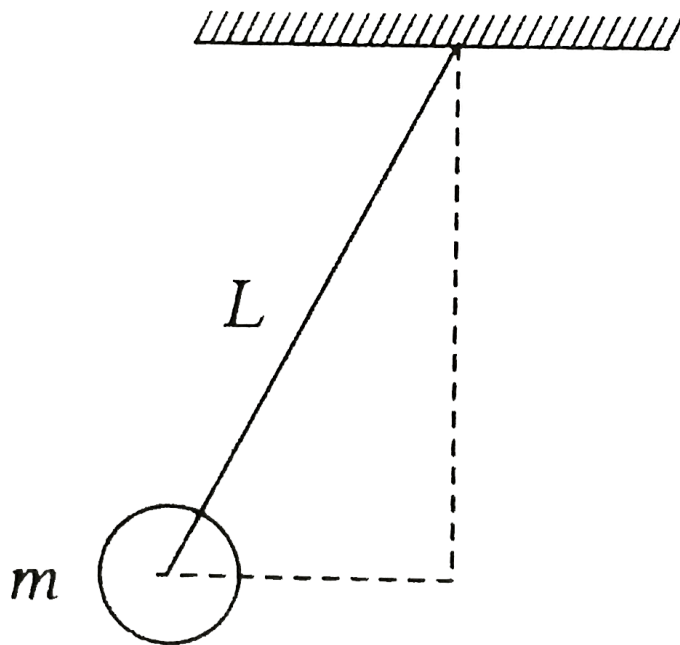

A. 9

B. 18

C. 27

D. 36

Answer: d



Watch Video Solution

13. A block of mass $m_1 = 1\text{kg}$ and another mass $m_2 = 2\text{kg}$ are placed together (see figure) on an inclined plane with angle of inclination θ . Various values of θ are given in list I. The coefficient of friction between the block m_1 and the plank is always zero. The coefficient of static and dynamic friction between the block m_2 and the plank are equal to $\mu = 0.3$. In List II, expressions for the friction on the block m_2 are given. Match the correct expressions of the frictionless in List II with the angle given in list I and choose the correct option. The acceleration due to gravity denoted by g .

[Useful

information

$$\tan(5.5^\circ) = 0.1 \tan(11.5^\circ) = 0.2 \tan(16.5^\circ) = 0.3]$$

List 1 P. $\theta = 5^\circ$ Q. $\theta = 10^\circ$

R. $\theta = 15^\circ$ S. $\theta = 20^\circ$

List 2

1. $m_2 g \sin \theta$ 2. $(m_1 + m_2) g \sin \theta$

3. $\mu m_2 g \cos \theta$ 4. $\mu (m_1 + m_2) g \cos \theta$

A. a. $P - 1, Q - 1, R - 1, S - 3$

B. b. $P - 2, Q - 2, R - 2, S - 3$

C. c. $P - 2, Q - 2, R - 2, S - 4$

D. d. $P - 2, Q - 2, R - 3, S - 3$

Answer: d



Watch Video Solution

Multiple correct answer type

1. A reference frame attached to the earth

A. a. is an inertial frame by definition

B. b. cannot be an inertial frame because the Earth
is revolving round the sun

C. c. is an inertial frame because Newton's laws are
applicable in this frame

D. d. cannot be an inertial frame because the Earth
is rotating about its own axis

Answer: b,c



2. A particle P is sliding down a frictionless hemispherical bowl. It passes the point A at $t = 0$. At this instant of time, the horizontal component of its velocity is v . A bead Q of the same mass as P is ejected from A at $t = 0$ along the horizontal string AB , with a speed v . Friction between the bead and the string may be neglected. Let t_P and t_Q be the respective times taken by P and Q to reach the point B . Then:

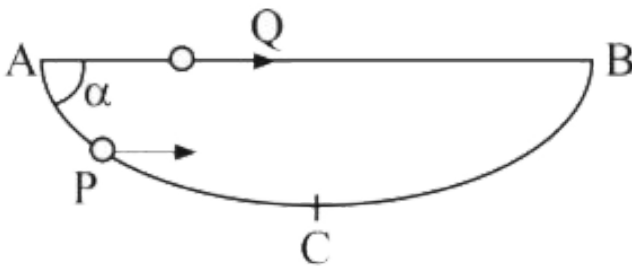

A. $t_p < t_Q$

B. $t_p = t_Q$

C. $t_p > t_Q$

D. $\frac{t_p}{t_Q} = \frac{\text{Length of arc } ACB}{\text{Length of } AB}$

Answer: a



Watch Video Solution

3. A small block of mass of 0.1 kg lies on a fixed inclined plane PQ which makes an angle θ with the horizontal. A horizontal force of 1N acts on the block through its centre of mass as shown in figure.

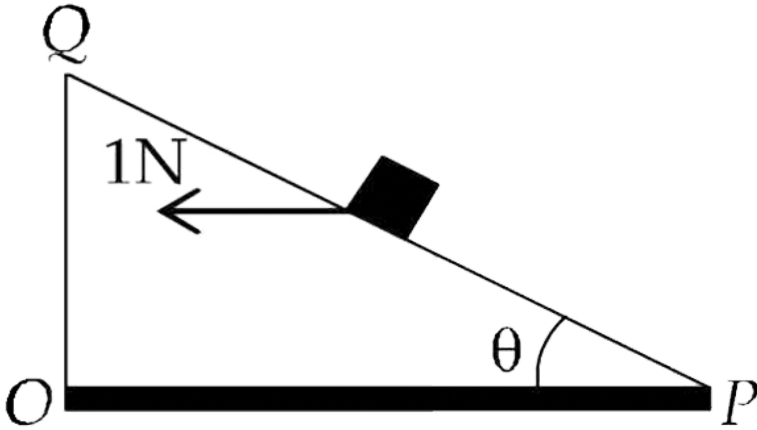

The block remains stationary if (take $g = 10\text{m/s}^2$)

A. $\theta = 45^\circ$

B. $\theta > 45^\circ$ and a frictional force acts on the block
toward P

C. $\theta > 45^\circ$ and a frictional force acts on the block
toward Q

D. $\theta < 45^\circ$ and a frictional force acts on the block
toward Q

Answer: a,c,



Watch Video Solution

Assertion -reasoning

1. STATEMENT-1: A cloth covers a table. Some dishes are kept on it. The cloth can be pulled out without dislodging the dishes from the table.

STATEMENT-2: For every action there is an equal and opposite reaction.

A. statement -I is true ,statement II is true

,Statement II is the correct explanation for

statement -I

B. Statement -I is true ,Statement II is true

statement II is not the correct explanation for

statement -I

C. Statement -I is true ,Statement II is false

D. Statement -I is false ,Statement II is true

Answer: b



Watch Video Solution

2. STATEMENT-1: It is easier to pull a heavy object than to push it on a level ground and

STATEMENT-2: The magnitude of frictional force depends on the nature of the two surfaces in contact.

A. statement -I is true ,statement II is true

,Statement II is the correct explanation for statement -I

B. Statement -I is true ,Statement II is true

statement II is not the correct explanation for statement -I

C. Statement -I is true ,Statement II is false

D. Statement -I is false ,Statement II is true

Answer: b



[Watch Video Solution](#)

Integer type

1. A block is moving on an inclined plane making an angle 45° with the horizontal and the coefficient of friction is μ . The force required to just push it up the inclined plane is 3 times the force required to just prevent it from sliding down. If we define $N = 10\mu$, then N is



[Watch Video Solution](#)