



PHYSICS

BOOKS - DC PANDEY ENGLISH

CALORIMETRY & HEAT TRANSFER

Example

1. How much heat is required to convert 8.0 g of ice at -15° to steam at 100° ? (Given, $c_{ice} = 0.53 \text{ cal/g} -^{\circ} \text{C}$, $L_f = 80 \text{ cal/g}$ and $L_v = 539 \text{ cal/g}$, and $c_{water} = 1 \text{ cal/g} -^{\circ} \text{C}$).

[Watch Video Solution](#)

2. In the above problem if heat is supplied at a constant rate of $q = 10\text{cal} / \text{min}$, then plot temperature versus time graph.

 [Watch Video Solution](#)

3. 10 g of water at $70^\circ C$ is mixed with 5 g of water at $30^\circ C$. Find the temperature of the mixture in equilibrium. Specific heat of water is $1\text{cal} / \text{g} - ^\circ C$.

 [Watch Video Solution](#)

4. The temperature of equal masses of three different liquids A, B and C are $12^{\circ}C$, $19^{\circ}C$ and $28^{\circ}C$ respectively. The temperature when A and B are mixed is $16^{\circ}C$ and when B and C are mixed it is $23^{\circ}C$. What should be the temperature when A and C are mixed?



[Watch Video Solution](#)

5. In a container of negligible mass 30g of steam at $100^{\circ}C$ is added to 200g of water that has a temperature of $40^{\circ}C$. If no heat is lost to the surroundings, what is the final temperature of the system? Also find masses of water and steam in equilibrium. Take $L_v = 539\text{cal/g}$ and $c_{\text{water}} = 1\text{cal/g} - ^{\circ}C$.

 [Watch Video Solution](#)

6. In a insulated vessel, 0.05 kg steam at 373 K and 0.45 kg of ice at 253 K are mixed. Find the final temperature of the mixture (in kelvin.)

$$\text{Given, } L_{\text{fusion}} = 80\text{cal/g} = 336\text{J/g}$$

$$L_{\text{vaporization}} = 540\text{cal/g} = 2268\text{J/g}$$

$$s_{\text{ice}} = 2100\text{J/kg} - \text{K} = 0.5\text{cal/g} - \text{K}$$

$$\text{and } s_{\text{water}} = 4200\text{J/kg} - \text{K} = 1\text{cal/g} - \text{K}.$$

 [Watch Video Solution](#)

7. An ice cube of mass 0.1 kg at 0°C is placed in an isolated container which is at 227°C . The specific heat s

of the container varies with temperature T according to the empirical relation $s = A + BT$, where $A = 100 \text{ cal/kgK}$ and $B = 2 \times (10^{-2}) \text{ cal/kg}$. If the final temperature of the container is 27°C , determine the mass of the container.

(Latent heat of fusion for water = $8 \times (10^4) \text{ cal/kg}$, specific heat of water = $10^3 \text{ cal/kg} - \text{K}$).



[Watch Video Solution](#)

8. In which of the following process, convection does not take place primarily?

(a) Sea and land breeze

(b) Boiling of water

(c) Warming of glass of bulb due to filament

(d) Heating air around a furnace

 [Watch Video Solution](#)

9. A copper rod 2 m long has a circular cross-section of radius 1 cm. One end is kept at $100^\circ C$ and the other at $0^\circ C$. The surface is insulated so that negligible heat is lost through the surface. In steady state, find

(a) the thermal resistance of the bar

(b) the thermal current H

(c) the temperature gradient $\frac{dT}{dx}$ and

(d) the temperature at a distance 25 cm from the hot end.

Thermal conductivity of copper is $401 W / m - K$.

 [Watch Video Solution](#)

10. Three rods made of the same material and having the same cross-section have been joined as shown in the figure. Each rod is of the same length. The left and right ends are kept at $0^{\circ}C$ and $90^{\circ}C$, respectively. The temperature of junction of the three rods will be

- (a) $45^{\circ}C$ (b) $60^{\circ}C$
(c) $30^{\circ}C$ (d) $20^{\circ}C$.

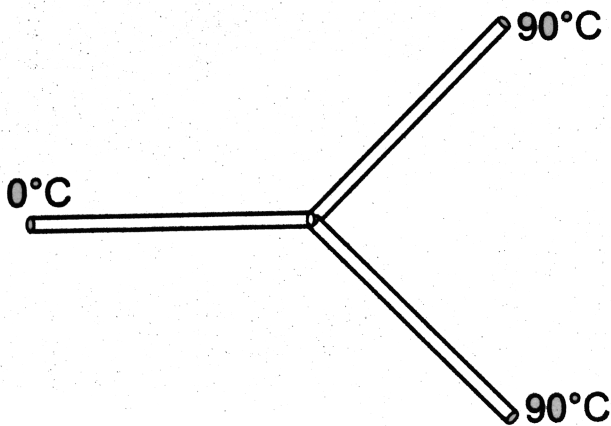

Watch Video Solution

11. Figure shows a copper rod joined to a steel rod. The rods have equal length and and the equal cross sectional area. The free end of the copper rod is kept at $0^{\circ}C$ and that of the steel rod is kept at $100^{\circ}C$. Find the temperature at the junction of the rods. conductivity of copper $= 390Wm^{-1}C^{-1}$ and that of steel $= 46Wm^{-1}C^{-1}$.

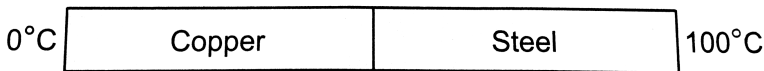

 [Watch Video Solution](#)

12. A spherical black body with a radius of 12 cm radiates 450 W power at 500 K. If the radius were halved and the

temperature doubled, the power radiated in watt would be

(a)225 (b)450

(c) 900 (d)1800



[Watch Video Solution](#)

13. A cylinder of radius R made of a material of thermal conductivity K_1 is surrounded by a cylindrical shell of inner radius R and outer radius $2R$ made of a material of thermal conductivity K_2 . The two ends of the combined system are maintained at two different temperatures. There is no loss of heat across the cylindrical surface and the system is in steady state. The effective thermal conductivity of the system is

(a) $K_1 + K_2$ (b) $K_1K_2 / (K_1 + K_2)$

(c) $(K_1 + 3K_2) / 4$

(d) $(3K_1 + K_2) / 4$.

 [Watch Video Solution](#)

14. A body cools in 10 minutes from $60^\circ C$ to $40^\circ C$. What will be its temperature after next 10 minutes? The temperature of the surroundings is $10^\circ C$.

 [Watch Video Solution](#)

Example Type 1

1. Thermal conductivity of the conductor shown in figure is K . Find thermal resistance between points a and b .

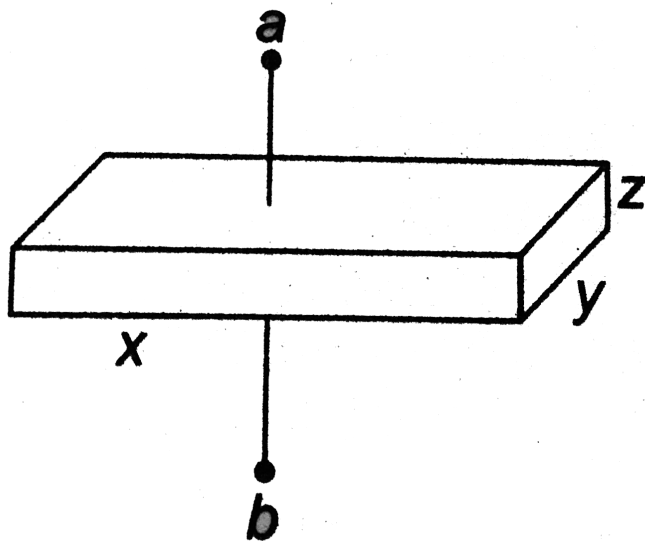

 [Watch Video Solution](#)

2. Thermal conductivity of inner core of radius r is K and of the outer one of radius $2r$ is $2K$. Find equivalent value

of thermal conductivity between its two ends.

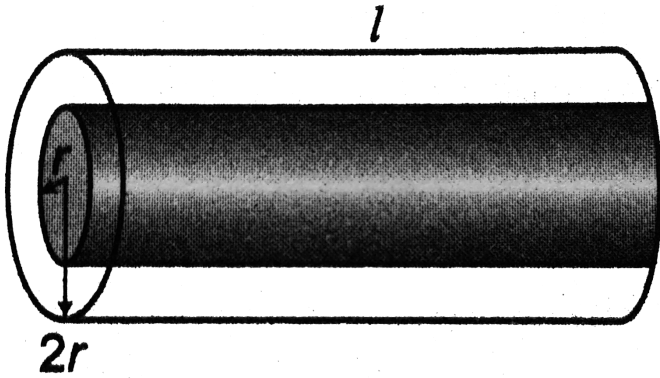

[▶ Watch Video Solution](#)

3. A spherical body of radius 'b' has a concentric cavity of radius 'a' as shown. Thermal conductivity of the material is K. Find thermal resistance between inner surface P and

outer surface Q.

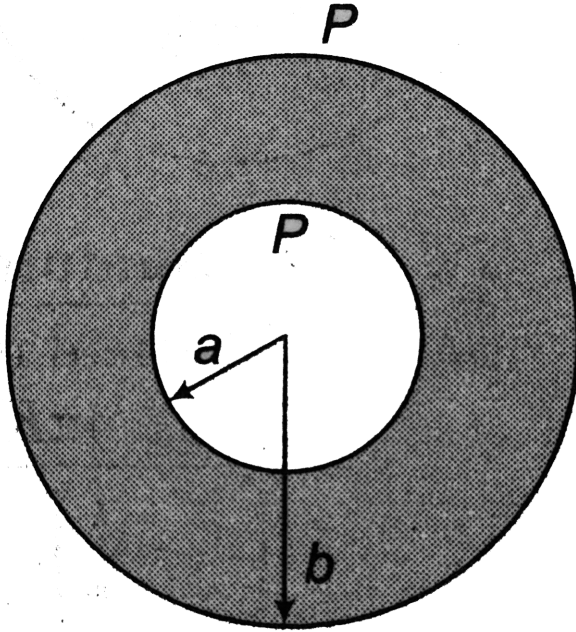

[▶ Watch Video Solution](#)

4. In the above example, if temperature of inner surface P is kept constant at θ_1 and of the outer surface Q at $\theta_2 (< \theta_1)$. Then,

Find.

(a) rate of heat flow or heat current from inner surface to outer surface.

(b) temperature θ at a distance r ($a < r < b$) from centre.



[Watch Video Solution](#)

Example Type 2

1. One end of the rod of length l , thermal conductivity K and area of cross-section A is maintained at a constant temperature of $100^\circ C$. At the other end large quantity of ice is kept at $0^\circ C$. Due to temperature difference, heat flows from left end to right end of the rod. Due to this heat ice will start melting. Neglecting the radiation losses

find the expression of rate of melting of ice.

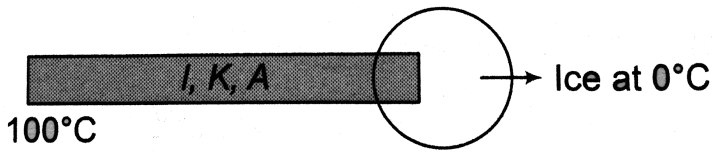

[Watch Video Solution](#)

2. B point of the rod shown in figure is maintained at $200^{\circ}C$. At left end A, there is water at $100^{\circ}C$ and at right end C there is ice at $0^{\circ}C$. Heat currents H_1 and H_2 will flow on both sides. Due to H_1 , water will convert into steam and due to H_2 ice will be melted. If latent heat of vaporization is $540\text{cal}/g$ and latent heat of fusion is $80\text{cal}/g$ then neglecting the radiation losses find $\frac{l_1}{l_2}$ so that rate of melting of ice is two times the rate of

conversion of water into steam.

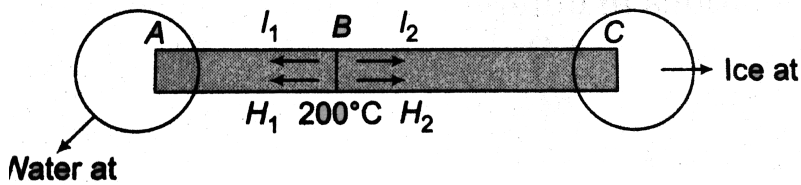

[Watch Video Solution](#)

Example Type 3

1. Three discs, A, B and C having radii 2m, 4m and 6m respectively are coated with carbon black on their outer surfaces. The wavelengths corresponding to maximum intensity are $300nm$, $400nm$ and $500nm$, respectively. The power radiated by them are Q_A , Q_B and Q_C respectively

(a) Q_A is maximum (b) Q_B is maximum (c) Q_C is maximum

(d) $Q_A = Q_B = Q_C$



[Watch Video Solution](#)

Example Type 4

1. Two spheres, one solid and other hollow are kept in atmosphere at same temperature. They are made of same material and their radii are also same. Which sphere will cool at a faster rate initially?



[Watch Video Solution](#)

2. The ratio of specific heats of two spheres is 2:3, radii 1:2, emissivity 3:1 and density 1:1. Initially, they are kept at same temperatures in atmosphere. Which sphere will cool at a faster rate initially.



[Watch Video Solution](#)

3. Two metallic spheres S_1 and S_2 are made of the same material and have got identical surface finish. The mass of S_1 is thrice that of S_2 . Both the spheres are heated to the same high temperature and placed in the same room having lower temperature but are thermally insulated from each other. the ratio of the initial rate of cooling of

S_1 to that of S_2 is

$$(a) \frac{1}{3} (b) \frac{1}{\sqrt{3}} (c) \frac{\sqrt{3}}{1} (d) \left(\frac{1}{3}\right)^{\frac{1}{3}}$$



[Watch Video Solution](#)

4. Two identical conducting rods are first connected independently to two vessels, one containing water at $100^\circ C$ and the other containing ice at $0^\circ C$. In the second case, the rods are joined end to end and connected to the same vessels. Let q_1 and q_2 gram per second be the rate of melting of ice in the two cases respectively. The ratio

$\frac{q_1}{q_2}$ is

$$(a) \frac{1}{2} (b) \frac{2}{1} (c) \frac{4}{1} (d) \frac{1}{4}$$



[Watch Video Solution](#)

Miscellaneous Examples

1. Two metal cubes with 3 cm- edges of copper and aluminium are arranged as shown in figure. Find

(a) the total thermal current from one reservoir to the other

(b) the ratio of the thermal current carried by the copper cube to that carried by the aluminium cube. Thermal conductivity of copper is 401 W/m-K and that of

aluminium id $237 \text{ W/m} \cdot \text{K}$.

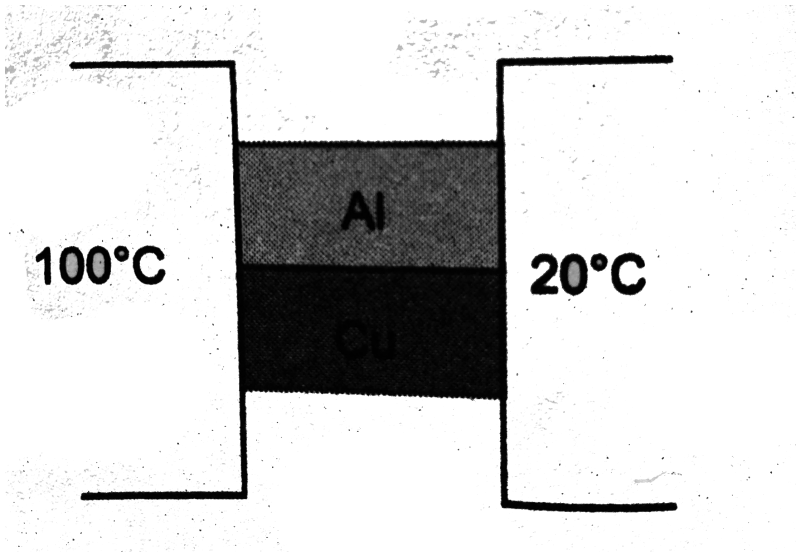

[▶ Watch Video Solution](#)

2. One end of a copper rod of length 1 m and area of cross-section $400 \times (10^{-4}) \text{ m}^2$ is maintained at 100°C . At the other end of the rod ice is kept at 0°C . Neglecting the loss of heat from the surrounding, find the mass of ice

melted

in

1h.

Given,

$$K_{Cu} = 401 \text{ W/m} \cdot \text{K} \text{ and } L_f = 3.35 \times (10^5) \text{ J/kg.}$$

 [Watch Video Solution](#)

3. Two bodies A and B have thermal emissivities of 0.01 and 0.81 respectively. The outer surface areas of the two bodies are same. The two bodies emit total radiant power at the same rate. The wavelength λ_B corresponding to maximum spectral radiancy from B is shifted from the wavelength corresponding to maximum spectral radiancy in the radiation from A by $1.0 \mu\text{m}$. If the temperature of A is 5802 K, calculate (a) the temperature of B, (b) wavelength λ_B .

 [Watch Video Solution](#)

4. 5g of water at $30^{\circ}C$ and 5g of ice at $-29^{\circ}C$ are mixed together in a calorimeter. Find the final temperature of mixture. Water equivalent of calorimeter is negligible, specific heat of ice = $0.5\text{cal/g} - ^{\circ}C$ and latent heat of ice = 80cal/g .



[Watch Video Solution](#)

5. A bullet of mass 10 g moving with a speed of 20m/s hits an ice block of mass 990 g kept on a frictionless floor and gets stuck in it. How much ice will melt if 50% of the lost kinetic energy goes to ice?

(Temperature of ice block = $0^{\circ}C$.)

 [Watch Video Solution](#)

6. At 1 atmospheric pressure, 1.000 g of water having a volume of 1.000cm^3 becomes 1671 cm^3 of steam when boiled. The heat of vaporization of water at 1 atmosphere is 539cal/g . What is the change in internal energy during the process ?

 [Watch Video Solution](#)

7. At 1 atmospheric pressure, 1000 g of water having a volume of 1000cm^3 becomes 1.097cm^3 of ice on freezing. The heat of fusion of water at 1 atmosphere is 80.0cal/g . What is the change in internal energy during the process?

 [Watch Video Solution](#)

8. Two plates each of area A , thickness L_1 and L_2 , thermal conductivities K_1 and K_2 respectively are joined to form a single plate of thickness $(L_1 + L_2)$. If the temperatures of the free surfaces are T_1 and T_2 . Calculate.

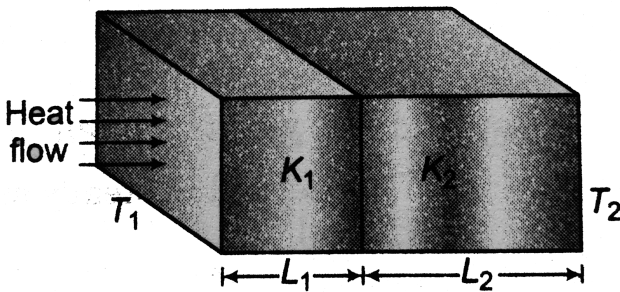

- (a) rate of flow of heat
- (b) temperature of interface and
- (c) equivalent thermal conductivity.

9. One end of a rod length 20cm is inserted in a furnace at 800K . The sides of the rod are covered with an insulating material and the other end emits radiation like a blackbody. The temperature of this end is 750K in the steady state. The temperature of the surrounding air is 300K . Assuming radiation to be the only important mode of energy transfer between the surrounding and the open end of the rod, find the thermal conductivity of the rod. Stefan constant $\sigma = 6.0 \times 10^{-8} \text{Wm}^{-2}\text{K}^{-4}$.



Watch Video Solution

10. Three rods of material x and three of material y are connected as shown in figure. All the rods are identical in length and cross sectional area. If the end A is maintained at $60^\circ C$ and the junction E at $10^\circ C$, calculate the temperature of the junction B . The thermal conductivity of x is $800 W m^{-1} \cdot ^\circ C^{-1}$ and that of y is $400 W m^{-1} \cdot ^\circ C^{-1}$.

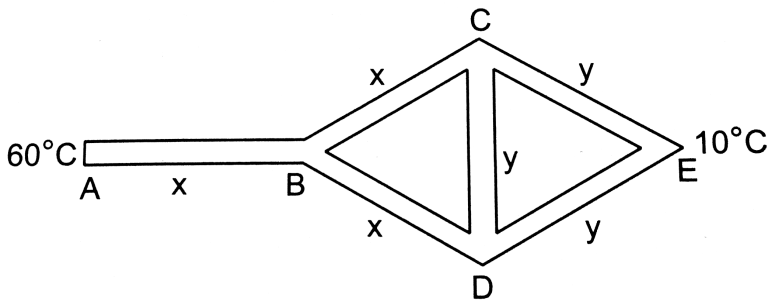

Watch Video Solution

11. A hollow sphere of glass whose external and internal radii are 11 cm and 9 cm respectively is completely filled with ice at $0^{\circ}C$ and placed in a bath of boiling water. How long will it take for the ice to melt completely? Given that density of ice = $0.9g/cm^3$, latent heat of fusion of ice = $80cal/g$ and thermal conductivity of glass = $0.002cal/cm - s^{\circ}C$.



Watch Video Solution

12. A point source of heat of power P is placed at the centre of a spherical shell of mean radius R . The material of the shell has thermal conductivity K . If the temperature difference between the outer and inner surface of the

shell in not to exceed T , the thickness of the shell should not be less than



[Watch Video Solution](#)

13. A steam cylindrical pipe of radius 5 cm carries steam at $100^{\circ}C$. The pipe is covered by a jacket of insulating material 2 cm thick having a thermal conductivity $0.07 W/m - K$. If the temperature at the outer wall of the pipe jacket is $20^{\circ}C$, how much heat is lost through the

jacket per metre length in an hours?

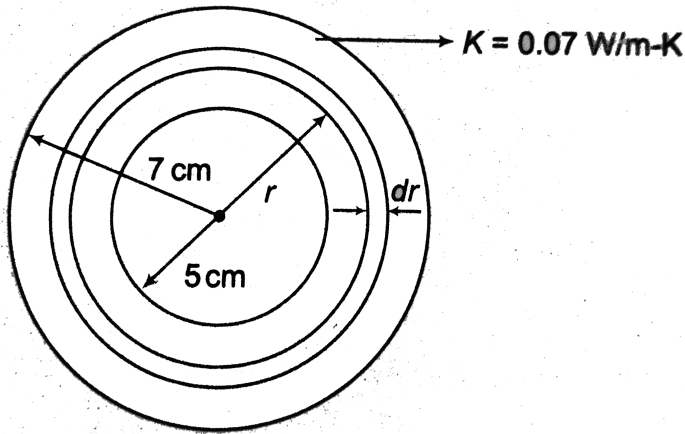

[Watch Video Solution](#)

Exercise 22 1

1. 10g ice at 0°C is converted into steam at 100°C . Find total heat required.

($L_f = 80 \text{ cal/g}$, $S_w = 1 \text{ cal/g} - ^\circ \text{C}$, $l_v = 540 \text{ cal/g}$)

[Watch Video Solution](#)

2. Three liquids A, B and C of specific heats $1\text{cal}/g - ^\circ C$, $0.5\text{cal}/g - ^\circ C$ and $0.25\text{cal}/g - ^\circ C$ are at temperatures $20^\circ C$, $40^\circ C$ and $60^\circ C$ respectively. Find temperature in equilibrium if they are mixed together. Their masses are equal.

 [Watch Video Solution](#)

3. Equal masses of ice ($at 0^\circ C$) and water are in contact. Find the temperature of water needed to just melt the complete ice.

 [Watch Video Solution](#)

4. A lead bullet just melts when stopped by an obstacle. Assuming that 25 per cent of the heat is absorbed by the obstacle, find the velocity of the bullet if its initial temperature is $27^{\circ}C$. (Melting point of lead= $327^{\circ}C$, specific heat of lead = $0.03\text{cal} / \text{gm} - ^{\circ}C$, latent heat of fusion of lead= $6\text{cal} / \text{gm}$, $J = 4.2J / \text{cal}$).

 [Watch Video Solution](#)

5. The temperature of 100g of water is to be raised from $24^{\circ}C$ to $90^{\circ}C$ by adding steam to it. Calculate the mass of the steam required for this purpose.

 [Watch Video Solution](#)

6. 15 g ice at $0^{\circ}C$ is mixed with 10 g water at $40^{\circ}C$. Find the temperature of mixture. Also, find mass of water and ice in the mixture.

 [Watch Video Solution](#)

7. Three liquids P, Q and R are given 4 kg of P at $60^{\circ}C$ and 1 kg of R at $50^{\circ}C$ when mixed produce a resultant temperature $55^{\circ}C$. A mixture of 1 kg of P at $60^{\circ}C$ and 1 kg of Q at $50^{\circ}C$ shows a temperature of $55^{\circ}C$. What will be the resulting temperature when 1 kg of Q at $60^{\circ}C$ is mixed with 1 kg of R at $50^{\circ}C$?

 [Watch Video Solution](#)

Exercise 22 2

1. A rod is heated at one end as shown in figure. In steady state temperature of different sections becomes constant but not same. Why so?

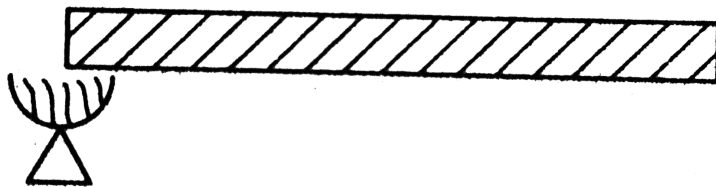

[▶ Watch Video Solution](#)

2. Show that the SI units of thermal conductivity are $W / m - K$.

[▶ Watch Video Solution](#)

3. Find SI units of thermal resistance.



[Watch Video Solution](#)

4. Suppose a liquid in a container is heated at the top rather than at the bottom. What is the main process by which the rest of the liquid becomes hot?



[Watch Video Solution](#)

5. Three rods each of same length and cross - section are joined in series. The thermal conductivity of the materials are K , $2K$ and $3K$ respectively. If one end is kept at $200^{\circ}C$ and the other at $100^{\circ}C$. What would be the

temperature of the junctions in the steady state? Assume that no heat is lost due to radiation from the sides of the rods.



Watch Video Solution

6. A rod CD of thermal resistance $5.0KW_{-1}$ is joined at the middle of an identical rod AB as shown in figure. The ends A, B and D are maintained at $100^{\circ}C$, $0^{\circ}C$ and

$25^{\circ}C$ respectively. Find the heat current in CD .

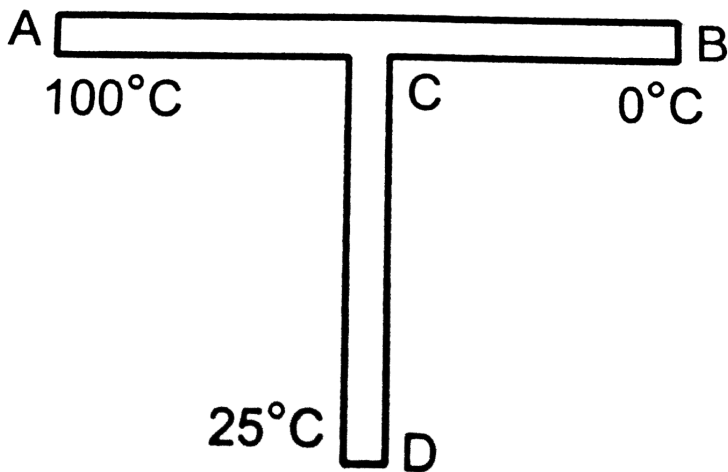

[Watch Video Solution](#)

7. A liquid takes 5 minutes to cool from $80^{\circ}C$ to $50^{\circ}C$.

How much time will it take to cool from $60^{\circ}C$ to $30^{\circ}C$?

The temperature of surroundings is $20^{\circ}C$.

[Watch Video Solution](#)

Assertion And Reason

1. Assertion : Specific heat of any substance remains constant at all temperatures.

Reason : It is given by $s = \frac{1}{m} \cdot \frac{dQ}{dt}$.

- A. If both Assertion and Reason are true and the Reason is correct explanation of the Assertion.
- B. If both Assertion and Reason are true but Reason is not the correct explanation of Assertion.
- C. If Assertion is true, but the Reason is false.
- D. If Assertion is false but the Reason is true.

Answer: D



2. Assertion : When temperature of a body is increased, in radiant energy, number of low wavelength photons get increased.

Reason : According to Wien's displacement law $\lambda_m \propto \frac{1}{T}$.

- A. If both Assertion and Reason are true and the Reason is correct explanation of the Assertion.
- B. If both Assertion and Reason are true but Reason is not the correct explanation of Assertion.
- C. If Assertion is true, but the Reason is false.
- D. If Assertion is false but the Reason is true.

Answer: A



Watch Video Solution

3. Assertion : Warming a room by a heat blower is an example of forced convection.

Reason : Natural convection takes place due to gravity.

A. If both Assertion and Reason are true and the

Reason is correct explanation of the Assertion.

B. If both Assertion and Reason are true but Reason is

not the correct explanation of Assertion.

C. If Assertion is true, but the Reason is false.

D. If Assertion is false but the Reason is true.

Answer: B



Watch Video Solution

4. Assertion : A conducting rod is placed between boiling water and ice. If rod is broken into two equal parts and two parts are connected side by side, then rate of melting of ice will increase ot four times.

Reason : Thermal resistance will become four times.

A. If both Assertion and Reason are true and the

Reason is correct explanation of the Assertion.

B. If both Assertion and Reason are true but Reason is

not the correct explanation of Assertion.

C. If Assertion is true, but the Reason is false.

D. If Assertion is false but the Reason is true.

Answer: C

 [Watch Video Solution](#)

5. Assertion : A normal body can radiate energy more than a perfectly black body.

Reason : A perfectly black body is always black in colour.

A. If both Assertion and Reason are true and the

Reason is correct explanation of the Assertion.

B. If both Assertion and Reason are true but Reason is not the correct explanation of Assertion.

C. If Assertion is true, but the Reason is false.

D. If Assertion is false but the Reason is true.

Answer: C



Watch Video Solution

6. Assertion : According to Newton's law, good conductors of electricity are also conductors of heat.

Reason : At a given temperature , $e_{\lambda} \propto a_{\lambda}$ for any body.

- A. If both Assertion and Reason are true and the Reason is correct explanation of the Assertion.
- B. If both Assertion and Reason are true but Reason is not the correct explanation of Assertion.
- C. If Assertion is true, but the Reason is false.
- D. If Assertion is false but the Reason is true.

Answer: D

 [Watch Video Solution](#)

7. Assertion : Good conductors of electricity are also good conductors of heat due to large number of free electrons.

Reason : It is easy to conduct heat from free electrons.

- A. If both Assertion and Reason are true and the Reason is correct explanation of the Assertion.
- B. If both Assertion and Reason are true but Reason is not the correct explanation of Assertion.
- C. If Assertion is true, but the Reason is false.
- D. If Assertion is false but the Reason is true.

Answer: A

 [Watch Video Solution](#)

8. Assertion : Emissivity of any body (e) is always less than its absorptive power (a).

Reason : Both the quantities are dimensionless.

- A. If both Assertion and Reason are true and the Reason is correct explanation of the Assertion.
- B. If both Assertion and Reason are true but Reason is not the correct explanation of Assertion.
- C. If Assertion is true, but the Reason is false.
- D. If Assertion is false but the Reason is true.

Answer: D

 [Watch Video Solution](#)

9. Assertion : Heat is supplied at constant rate from one end of a conducting rod. In steady state, temperature of all points of the rod becomes uniform.

Reason : In steady state, temperature of rod does not increase.

A. If both Assertion and Reason are true and the Reason is correct explanation of the Assertion.

B. If both Assertion and Reason are true but Reason is not the correct explanation of Assertion.

C. If Assertion is true, but the Reason is false.

D. If Assertion is false but the Reason is true.

Answer: D



Watch Video Solution

10. Assertion : A solid sphere and a hollow sphere of same material and same radius are kept at same temperature in atmosphere. Rate of cooling of hollow sphere will be more.

Reason : If all other conditions are same, then rate of cooling is inversely proportional to the mass of body.

A. If both Assertion and Reason are true and the

Reason is correct explanation of the Assertion.

B. If both Assertion and Reason are true but Reason is

not the correct explanation of Assertion.

C. If Assertion is true, but the Reason is false.

D. If Assertion is false but the Reason is true.

Answer: A



Watch Video Solution

Level 1 Objective

1. For an enclosure maintained at 2000K, the maximum radiation occurs at wavelength λ_m . If the temperature is raised to 3000K, the peak will shift to

A. $0.5\lambda_m$

B. λ_m

C. $\frac{2}{3}\lambda_m$

D. $\frac{3}{2}\lambda_m$

Answer: C



Watch Video Solution

2. A substance cools from $75^{\circ}C$ to $70^{\circ}C$ in T_1 minute, from $70^{\circ}C$ to $65^{\circ}C$ in T_2 minute and from $65^{\circ}C \rightarrow 60^{\circ}C$ in T_3 minute, then.

A. $T_1 = T_2 = T_3$

B. $T_1 < T_2 < T_3$

C. $T_1 > T_2 > T_3$

D. $T_1 > T_2 = T_3$

Answer: B



Watch Video Solution

3. Two liquids are at temperatures $20^{\circ}C$ and $40^{\circ}C$. When same mass of both of them is mixed, the temperature of the mixture is $32^{\circ}C$. What is the ratio of their specific heats?

A. $1/3$

B. $2/5$

C. $3/2$

D. $2/3$

Answer: D



4. The specific heat of a metal at low temperatures varies according to $S = aT^3$, where a is a constant and T is absolute temperature. The heat energy needed to raise unit mass of the metal from temperature $T = 1K$ to $T = 2K$ is

A. $3a$

B. $\frac{15a}{4}$

C. $\frac{2a}{3}$

D. $\frac{13a}{4}$

Answer: B



Watch Video Solution

5. The intensity of radiation emitted by the sun has its maximum value at a wavelength of 510 nm and that emitted by the North star has the maximum value at 350 nm. If these stars behave like black bodies, then the ratio of the surface temperature of the sun and North star is

A. 1.46

B. 0.69

C. 1.21

D. 0.83

Answer: B



[Watch Video Solution](#)

6. A solid material is supplied heat at a constant rate. The temperature of material is changing with heat input as shown in the figure. What does the slope of DE represent

?

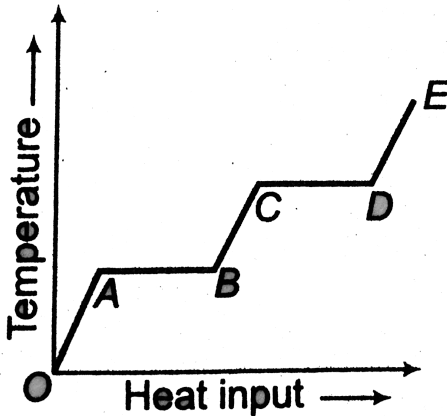

- A. Latent heat of liquid
- B. Latent heat of vaporization
- C. Heat capacity of vapour
- D. Inverse of heat capacity of vapour

Answer: D



Watch Video Solution

7. Two ends of rods of length L and radius R of the same material of kept at the same temperature. Which of the following rods conducts the maximum heat?

A. $L=50$ cm, $R = 1$ cm

B. $L = 100$ cm, $R = 2$ cm

C. $L = 25$ cm, $R = 0.5$ cm

D. $L = 75$ cm , $R = 1.5$ cm

Answer: B



Watch Video Solution

8. 1 g of ice at $0^{\circ}C$ is mixed with 1 g of steam at $100^{\circ}C$. After thermal equilibrium is achieved, the temperature of the mixture is

A. $100^{\circ}C$

B. $55^{\circ}C$

C. $75^{\circ}C$

D. $0^{\circ}C$

Answer: A



9. A wall has two layers A and B each made of different materials. The layer A is 10cm thick and B is 20 cm thick. The thermal conductivity of A is thrice that of B. Under thermal equilibrium temperature difference across the wall is $35^{\circ}C$. The difference of temperature across the layer A is

A. $30^{\circ}C$

B. $14^{\circ}C$

C. $8.75^{\circ}C$

D. $5^{\circ}C$

Answer: D



Watch Video Solution

10. A wall is made of equally thick layers A and B of different materials. Thermal conductivity of A is twice that of B. In the steady state, the temperature difference across the wall is $36^{\circ}C$. The temperature difference across the layer A is

A. $6^{\circ}C$

B. $12^{\circ}C$

C. $18^{\circ}C$

D. $24^{\circ}C$

Answer: B



Watch Video Solution

11. The end of two rods of different materials with their thermal conductivities, area of cross-section and lengths all in the ratio 1:2 are maintained at the same temperature difference. If the rate of flow of heat in the first rod is 4 cal/s . Then, in the second rod rate of heat flow in cal/s will be

A. 1

B. 2

C. 8

D. 16

Answer: C



Watch Video Solution

Level 1 Subjective

1. A thin square steel plate 10 cm on a side is heated in a black smith's forge to temperature of $800^{\circ}C$. If the emissivity is 0.60, what is the total rate of radiation of energy ?



[Watch Video Solution](#)

2. A lead bullet penetrates into a solid object and melts. Assuming that 50% of its K.E. was used to heat it, calculate the initial speed of the bullet, The initial temp, of bullet is $27^{\circ}C$ and its melting point is $327^{\circ}C$ Latent

heat of fusion of lead = $2.5 \times 10^4 \text{ Jkg}^{-1}$ and sp heat

capacity of lead = $125 \text{ Jkg}^{-1} \text{ K}^{-1}$



[Watch Video Solution](#)

3. A ball is dropped on a floor from a height of 2.0 m . After the collision it rises up to a height of 1.5 m . Assume that 40% of the mechanical energy lost goes as thermal energy into the ball. Calculate the rise in the temperature of the ball in the collision. Heat capacity of the ball is 800 JK^{-1}



[Watch Video Solution](#)

4. A nuclear power plant generates 500 MW of waste heat that must be carried away by water pumped from a lake. If the water temperature is to rise by $10^{\circ}C$, what is the required flow rate in kg/s ?

 [Watch Video Solution](#)

5. The emissivity of tungsten is 0.4. A tungsten sphere with a radius of 4.0 cm is suspended within a large evacuated enclosure whose walls are at 300 K. What power input is required to maintain the sphere at a temperature of 3000 K if heat conduction along supports is neglected ?

Take, $\sigma = 5.67 \times (10^{-8}) Wm^2 - K^4$.

 [Watch Video Solution](#)

6. A pot with a steel bottom 1.2 cm thick rests on a hot stove. The area of the bottom of the pot is 0.150m^2 . The water inside the pot is at 100°C and 0.440kg are evaporated every 5.0 minute. Find the temperature of the lower surface of the pot, which is in contact with the stove. Take

$$L_v = 2.256 \times (10^6) J / kg \text{ and } k_{steel} = 50.2 W / m - K .$$

 [Watch Video Solution](#)

7. A carpenter builds an outer house wall with a layer of wood 2.0 cm thick on the outside and a layer of an

insulation 3.5 cm thick as the inside wall surface. The wood has $K = 0.08 \text{ W/m.K}$ and the insulation has $K = 0.01 \text{ W/m.K}$. The interior surface temperature is 19°C and the exterior surface temperature is -10°C .

(a) What is the temperature at the plane where the wood meets the insulation?

(b) What is the rate of heat flow per square metre through this wall ?

 [Watch Video Solution](#)

8. A closely thermally insulated vessel contains 100 g of water at 0°C . If the air from this vessel is rapidly pumped out, intensive evaporation will produce cooling and as a result of this, water freeze. How much ice will be formed

by this method? If latent heat of fusion is $80\text{cal}/g$ and of evaporation $560\text{cal}/g$.

[Hint If m gram ice is formed, $mL_f = (100 - m)l_v$]

 [Watch Video Solution](#)

9. In a container of negligible mass 140 g of ice initially at -15°C is added to 200 g of water that has a temperature of 40°C . If no heat is lost to the surroundings, what is the final temperature of the system and masses of water and ice in mixture ?

 [Watch Video Solution](#)

10. A certain amount of ice is supplied heat at a constant rate for 7 minutes. For the first one minute the temperature rises uniformly with time. Then, it remains constant for the next 4 minute and again the temperature rises at uniform rate for the last two minutes. Calculate the final temperature at the end of seven minutes.

(Given, L of ice $= 336 \times (10^3) J/kg$ and specific heat of water $= 4200 J/kg - K$).



[Watch Video Solution](#)

11. Four identical rods AB , CD , CF and DE are joined as shown in figure. The length, cross-sectional area and

thermal conductivity of each rod are l , A and K respectively. The ends A , E and F are maintained at temperature T_1 , T_2 and T_3 respectively. Assuming no loss of heat to the atmosphere, find the temperature at B .

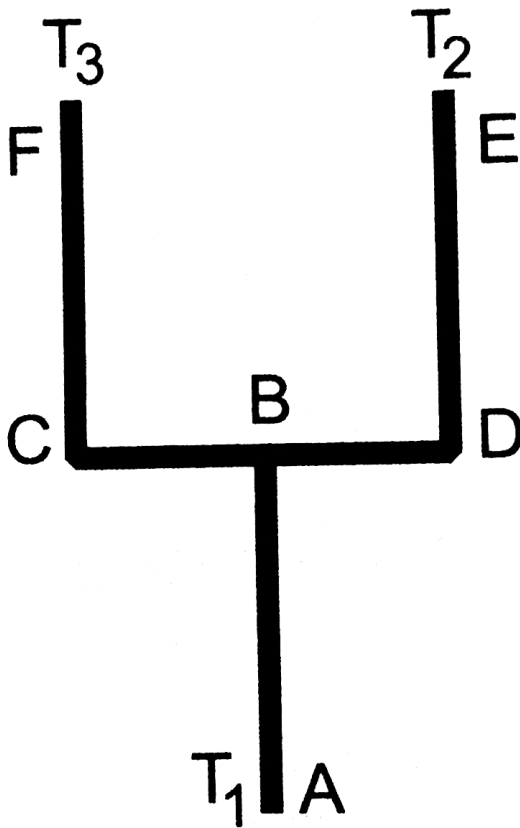

 Watch Video Solution

12. The ends of a copper rod of length 1m and area of cross-section 1cm^2 are maintained at 0°C and 100°C . At the centre of the rod there is a source of heat of power 25 W. Calculate the temperature gradient in the two halves of the rod in steady state. Thermal conductivity of copper is $400\text{Wm}^{-1}\text{K}^{-1}$.



Watch Video Solution

13. A copper sphere is suspended in an evacuated chamber maintained at 300K . The sphere is maintained at a constant temperature of 500K by heating it electrically. A total of 210W of electric power is needed to do it. When the surface of the copper sphere is completely blackened,

$700W$ is needed to maintain the same temperature of the sphere. Calculate the emissivity of copper.



[Watch Video Solution](#)

Level 2 Single Correct

1. A cylindrical rod with one end in a steam chamber and the other end in ice results in melting of 0.1 g of ice per second. If the rod is replaced by another with half the length and double the radius of the first and if the thermal conductivity of material of second rod is $1/4$ that of first, the rate at which ice melts in g/s will be

A. (a) 0.4

B. (b) 0.05

C. (c) 0.2

D. (d) 0.1

Answer: C



Watch Video Solution

2. Two sheets of thickness d and $3d$, are touching each other. The temperature just outside the thinner sheet is T_1 and on the side of the thicker sheet is T_3 . The interface temperature is T_2 . T_1, T_2 and T_3 are in arithmetic progression. The ratio of thermal conductivity of thinner sheet to thicker sheet is .

A. (a) 1:3

B. (b) 3:1

C. (c) 2:3

D. (d) 3:9

Answer: A



Watch Video Solution

3. A long rod has one end at $0^\circ C$ and other end at a high temperature. The coefficient of thermal conductivity varies with distance from the low temperature end as $K = K_0(1 + ax)$, where $K_0 = 10^2$ SI unit and $a = 1m^{-1}$. At what distance from the first end the

temperature will be $100^{\circ}C$? The area of cross-section is 1cm^2 and rate of heat conduction is 1 W.

- A. 2.7 m
- B. 1.7m
- C. 3 m
- D. 1.5 m

Answer: B

 [Watch Video Solution](#)

4. Two rods are of same material and having same length and area. If heat ΔQ flows through them for 12 min when they are joined side by side. If now both the rods are

joined in parallel, then the same amount of heat ΔQ will flow in

- A. 24 min
- B. 3 min
- C. 12 min
- D. 6 min

Answer: B

 [Watch Video Solution](#)

5. Three rods of identical cross-sectional area and made from the same metal form the sides of an isosceles triangle ABC right angled at B as shown in the figure. The

points A and B are maintained at temperature T and $(\sqrt{2})T$ respectively in the steady state. Assuming that only heat conduction takes place, temperature of point C will be

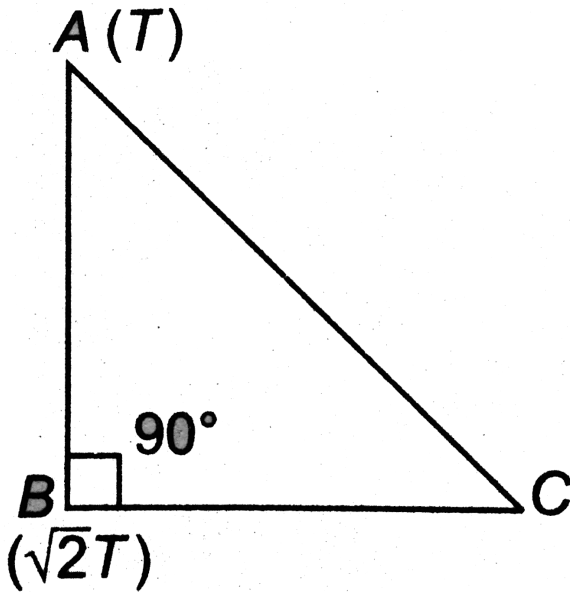

- A. $\frac{T}{(\sqrt{2}) - 1}$
- B. $\frac{T}{(\sqrt{2}) + 1}$

C. $\frac{3T}{(\sqrt{2}) + 1}$

D. $\frac{T}{(\sqrt{3})(\sqrt{2} - 1)}$

Answer: C



Watch Video Solution

6. A kettle with 2 litre water at $27^{\circ}C$ is heated by operating coil heater of power 1 kW. The heat is lost to the atmosphere at constant rate $160J/s$, when its lid is open. In how much time will water heated to $77^{\circ}C$ with the lid open ? (specific heat of water = $4.2kJ/^{\circ}C - kg$)

A. 8 min 20 s

B. 6 min 2 s

C. 14 min

D. 7 min

Answer: A



Watch Video Solution

7. The temperature of the two outer surfaces of a composite slab consisting of two materials having coefficient of thermal conductivity K and $2K$ and thickness x and $4x$ respectively are T_2 and T_1 ($T_2 > T_1$). The rate of heat transfer through the slab in steady state is

$\left(\frac{AK(T_2 - T_1)}{x}\right) f$. where, f is equal to

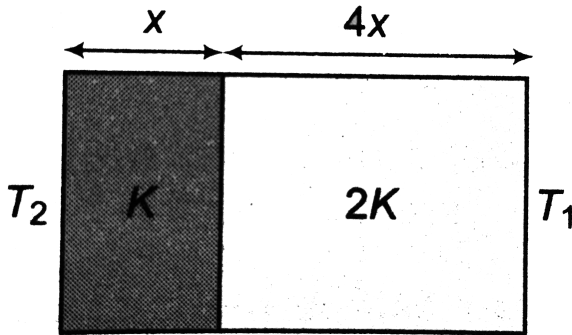

- A. 1
- B. $1/2$
- C. $2/3$
- D. $1/3$

Answer: D

 [Watch Video Solution](#)

Level 2 More Than One Correct

1. A solid sphere and a hollow sphere of the same material and of equal radii are heated to the same temperature

A. both will emit equal amount of radiation per unit time in the beginning

B. both will absorb equal amount of radiation per second from the surroundings in the beginning

C. the initial rate of cooling will be the same for both the spheres

D. the two spheres will have equal temperatures at any instant

Answer: A:B

 Watch Video Solution

2. Three identical conducting rods are connected as shown in figure. Given that $\theta_a = 40^\circ C$, $\theta_c = 30^\circ C$ and $\theta_d = 20^\circ C$. Choose the correct options.

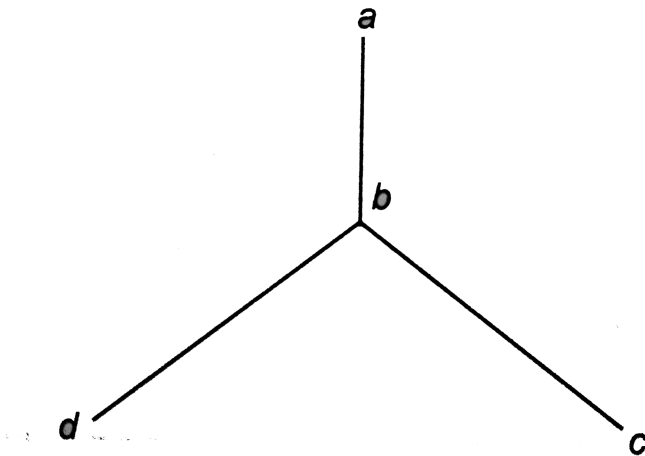

A. temperature of junction b is $15^\circ C$.

B. temperature of junction b is $30^{\circ} C$

C. heat will flow from c to b

D. heat will flow from b to d

Answer: B::D



Watch Video Solution

3. Two liquids of specific heat ratio 1:2 are at temperature 2θ and θ

A. if equal amounts of them are mixed, then temperature of mixture is 1.5θ

B. if equal amounts of them are mixed, then

temperature of mixture is $\frac{4}{3}\theta$

C. for their equal amounts, the ratio of heat capacities

is 1:1

D. for their equal amounts, the ratio of their heat

capacities is 1:2.

Answer: B::D

 [Watch Video Solution](#)

4. Two conducting rods when connected between two points at constant but different temperatures separately, the rate of heat flow through them is q_1 and q_2 .

A. When they are connected in series, the net rate of

heat flow is $q_1 + q_2$

B. When they are connected in series, the net rate of

heat flow is $\left(\frac{q_1 q_2}{q_1 + q_2} \right)$

C. When they are connected in parallel, the net rate of

heat flow is $q_1 + q_2$

D. When they are connected in parallel, the net rate of

heat flow is $\left(\frac{q_1 q_2}{q_1 + q_2} \right)$

Answer: B::C



Watch Video Solution

5. Choose the correct options.

A. Good absorbers of a particular wavelength are good emitters of same wavelength. This statement was given by Kirchhoff.

B. At low temperature of a body the rate of cooling is directly proportional to temperature of the body.

This statement was given by the Newton

C. Emissive power of a perfectly black body is 1

D. Absorptive power of a perfectly black body is 1

Answer: A::D



Watch Video Solution

Level 2 Subjective

1. As a physicist, you put heat into a 500 g solid sample at the rate of $10.0 \text{ kJ} / \text{min}$, while recording its temperature as a function of time. You plot your data and obtain the graph shown in figure.

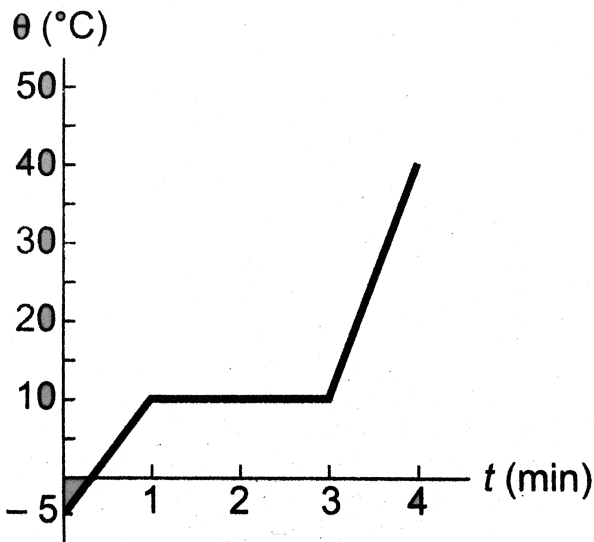

- (a) What is the latent heat of fusion for this solid?
- (b) What is the specific heat of solid state of the material?



[Watch Video Solution](#)

2. A hot body placed in air is cooled down according to Newton's law of cooling, the rate of decrease of temperature being k times the temperature difference from the surrounding. Starting from $t = 0$, find the time in which the body will lose half the maximum heat it can lose.



[Watch Video Solution](#)

3. Three rods of copper, brass and steel are welded together to form a Y-shaped structure. The cross-sectional area of each rod is 4cm^2 . The end of copper rod

is maintained at $100^{\circ}C$ and the ends of the brass and steel rods at $80^{\circ}C$ and $60^{\circ}C$ respectively. Assume that there is no loss of heat from the surfaces of the rods. The lengths of rods are : copper 46 cm, brass 13 cm and steel 12 cm.

(a) What is the temperature of the junction point?

(b) What is the heat current in the copper rod?

$K(\text{copper}) = 0.92$, $K(\text{steel}) = 0.12$ and $K(\text{brass}) = 0.26$
 $\text{cal} / \text{cm} - \text{s}^{\circ}C$.



[Watch Video Solution](#)

4. Ice at $0^{\circ}C$ is added to 200 g of water initially at $70^{\circ}C$ in a vacuum flask. When 50 g of ice has been added and has all melted the temperature of the flask and contents

is $40^{\circ}C$. When a further 80 g of ice has been added and has all melted the temperature of the whole becomes $10^{\circ}C$. Find the latent heat of fusion of ice.

 [Watch Video Solution](#)

5. A copper cube of mass 200g slides down an a rough inclined plane of inclination 37° at a constant speed. Assume that any loss in mechanical energy goes into the copper block as thermal energy .Find the increase in the temperature of the block as it slides down through 60cm. Specific heat capacity of copper = $420Jkg^{-1}K^{-1}$

 [Watch Video Solution](#)

6. A cylindrical block of length 0.4 m and area of cross-section $0.04m^2$ is placed coaxially on a thin metal disc of mass 0.4 kg and of the same cross - section. The upper face of the cylinder is maintained at a constant temperature of 400 K and the initial temperature of the disc is 300K. if the thermal conductivity of the material of the cylinder is $10\text{watt}/m - K$ and the specific heat of the material of the disc is $600J/kg - K$, how long will it take for the temperature of the disc to increase to 350 K? Assume for purpose of calculation the thermal conductivity of the disc to be very high and the system to be thermally insulated except for the upper face of the cylinder.



[Watch Video Solution](#)

7. A metallic cylindrical vessel whose inner and outer radii are r_1 and r_2 is filled with ice at $0^\circ C$. The mass of the ice in the cylinder is m . Circular portions of the cylinder is sealed with completely adiabatic walls. The vessel is kept in air. Temperature of the air is $50^\circ C$. How long will it take for the ice to melt completely. Thermal conductivity of the cylinder is K and its length is l . Latent heat of fusion of L .



[Watch Video Solution](#)

8. An electric heater is placed inside a room of total wall area $137m^2$ to maintain the temperature inside at $20^\circ C$. The outside temperature is $-10^\circ C$. The walls are made of three composite materials. The inner most layer is made

of wood of thickness 2.5 cm the middle layer is of cement of thickness 1 cm and the exterior layer is of brick of thickness 2.5 cm. Find the power of electric heater assuming that there is no heat losses through the floor and ceiling. The thermal conductivities of wood, cement and brick are $0.125 \text{ W/m}^\circ - \text{C}$, $1.5 \text{ W/m}^\circ - \text{C}$ and $1.0 \text{ W/m}^\circ - \text{C}$ respectively.



[Watch Video Solution](#)

9. A 2 m long wire of resistance 4Ω and diameter 0.64 mm is coated with plastic insulation of thickness 0.66 mm. A current of 5A flows through the wire. Find the temperature difference across the insulation in the steady

state. Thermal conductivity of plastic is

$$0.16 \times (10^{-2}) \text{ cal / scm}^\circ - C.$$

 [Watch Video Solution](#)

10. Two bodies of masses m_1 and m_2 and specific heat capacities S_1 and S_2 are connected by a rod of length l , cross-section area A , thermal conductivity K and negligible heat capacity. The whole system is thermally insulated. At time $t = 0$, the temperature of the first body is T_1 and the temperature of the second body is $T_2 (T_2 > T_1)$. Find the temperature difference between the two bodies at time t .

 [Watch Video Solution](#)

11. A rod of length l with thermally insulated lateral surface consists of material whose heat conductivity coefficient varies with temperature as $k = a/T$, where a is a constant. The ends of the rod are kept at temperatures T_1 and T_2 . Find the function $T(x)$, where x is the distance from the end whose temperature is T_1 .



Watch Video Solution

12. One end of a uniform brass rod 20 cm long and 10cm^2 cross-sectional area is kept at 100°C . The other end is in perfect thermal contact with another rod of identical cross-section and length 10 cm. The free end of this rod is kept in melting ice and when the steady state has been

reached, it is found that 360 g of ice melts per hour.

Calculate the thermal conductivity of the rod, given that

the thermal conductivity of brass is

$0.25 \text{ cal / scm}^\circ \text{ C}$ and $L = 80 \text{ cal / g}$.



[Watch Video Solution](#)

13. Heat flows radially outwards through a spherical shell of outside radius R_2 and inner radius R_1 . The temperature of inner surface of shell is θ_1 and that of outer is θ_2 . At what radial distance from centre of shell the temperature is just half way between θ_1 and θ_2 ?



[Watch Video Solution](#)

14. A layer of ice of thickness y is on the surface of a lake. The air is at a constant temperature $-\theta^{\circ}C$ and the ice water interface is at $0^{\circ}C$. Show that the rate at which the thickness increases is given by

$$\frac{dy}{dt} = \frac{K\theta}{L\rho y}$$

where, K is the thermal conductivity of the ice, L the latent heat of fusion and ρ is the density of the ice.



[Watch Video Solution](#)