



PHYSICS

BOOKS - DC PANDEY ENGLISH

CENTRE OF MASS, IMPULSE AND MOMENTUM

Only One Option Is Correct For Jee Mains

1. The centre of mass of the shaped portion of the disc is (The mass is uniformly distributed in the shaded portion)

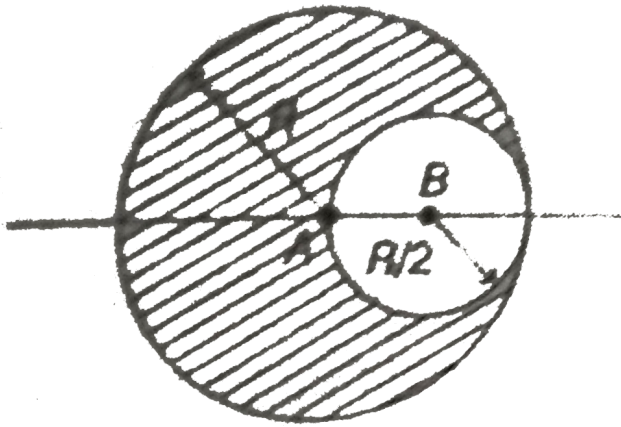

- A. $\frac{R}{6}$ to the left of A
- B. $\frac{R}{12}$ to the left A
- C. $\frac{R}{6}$ to the right of A
- D. $\frac{R}{12}$ to the right of A

Answer:



Watch Video Solution

2. Two particles having mass ratio $n : 1$ are interconnected by a light inextensible string that passes over a smooth pulley . If the system is released , then the acceleration of the centre of mass of the system is

A. $(n - 1)^2 g$

B. $\left(\frac{n + 1}{n - 1}\right)^2 g$

C. $\left(\frac{n - 1}{n + 1}\right)^2 g$

D. $\left(\frac{n + 1}{n - 1}\right)g$

Answer:



Watch Video Solution

3. A ball of mass 50 gm is dropped from a height $h=10\text{m}$. It rebounds losing 75 percent of its kinetic energy. If it remains in contact with the ground for $\Delta t = 0.01$ sec. the impulse of the impact force is (take $g = 10\text{m/s}^2$)

A. $1.3\text{N} - \text{s}$

B. 1.06 N-s

C. 1300 N-s

D. 105 N-s

Answer:



Watch Video Solution

4. In an arrangement shown, bob A on the left is pulled aside. It is then released and allowed to collide with other bob B which is at rest. A perfectly inelastic collision occurs and the system rises to a height $h/4$. The ratio of the masses of the bobs is

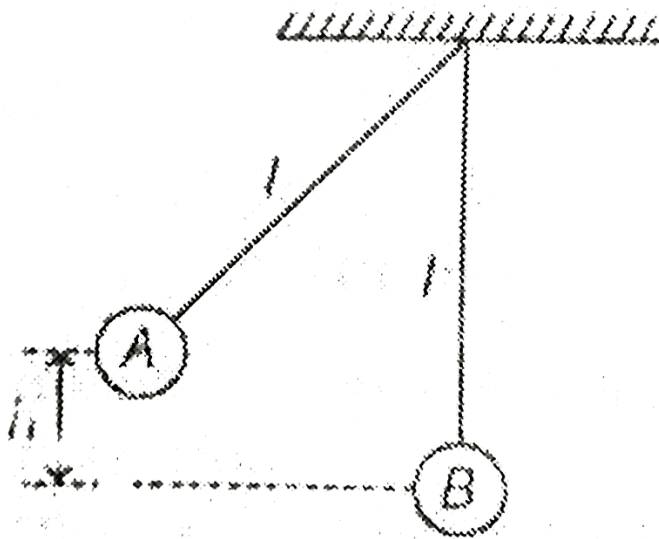

- A. 1
- B. 2
- C. 3

D. 4

Answer:

 [Watch Video Solution](#)

5. There are hundred identical blocks equally spaced on a frictionless track as shown in the figure . Initially , all the blocks are separate . Each collision is perfectly inelastic . The final velocity will be

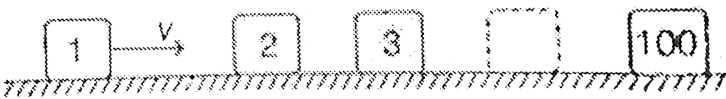

A. $\frac{V}{99}$

B. $\frac{V}{100}$

C. zero

D. NONE

Answer:



Watch Video Solution

6. A stationary body explodes into two fragments of masses m_1 and m_2 . If momentum of one fragment is p , the energy of explosion is

A. $\frac{p^2}{2(m_1 + m_2)}$

B. $\frac{p^2}{2\sqrt{m_1 + m_2}}$

C. $\frac{p^2(m_1 + m_2)}{2m_1m_2}$

D. $\frac{p^2(m_1 + m_2)}{m_1m_2}$

Answer:

 [Watch Video Solution](#)

7. A ball collides with an inclined plane of inclination θ after falling through a distance h . if it moves horizontal just after the impact, the coefficient of restitution is

A. $\tan^2 \theta$

B. $\cot^2 \theta$

C. $\tan \theta$

D. $\cot \theta$

Answer:

 [Watch Video Solution](#)

8. Three blocks are initially placed as shown in the figure. Block A has mass m and initial velocity v to the right. Block B with mass m and block C with mass $4m$ are both initially at rest. Neglect friction. All collisions are elastic. The final velocity of blocks A is

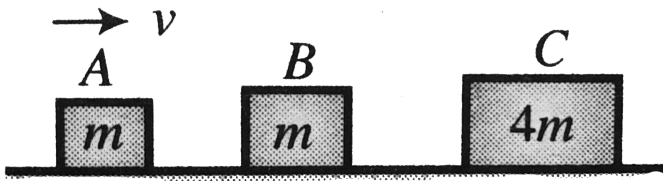

- A. $0.6 v$ to the left
- B. $0.4 v$ to the left
- C. v to the left
- D. $0.4 v$ to the right

Answer:



Watch Video Solution

9. A force exerts an impulse I on a particle changing its speed from initial velocity u to final velocity $2u$. The applied force and the initial velocity are oppositely oriented along the same line.

The work done by the force is

A. $\frac{3}{2} I u$

B. $\frac{1}{2} I u$

C. $I u$

D. $2 I u$

Answer:



Watch Video Solution

10. A ball is projected from ground with a velocity V at an angle θ to the vertical. On its path it makes an elastic collision with a vertical wall and returns to ground. The total time of flight of the ball is

A. $\frac{2v\sin\theta}{g}$

B. $\frac{2v\cos\theta}{g}$

C. $\frac{v\sin 2\theta}{g}$

D. $\frac{v\cos\theta}{g}$

Answer:



Watch Video Solution

11. An open water tight railway wagon of mass $5 \times 10^3 \text{ kg}$ moves at an initial velocity 1.2 m/s without friction on a railway track.

Rain drops fall vertically downwards into the wagon. The velocity of the wagon after it has collected 10^3 kg of water will be :-

A. 0.5 m/s

B. 0.6 m/s

C. 1 m/s

D. 0.8 m/s

Answer:



[Watch Video Solution](#)

12. A rocket of mass 4000 kg is set for vertical firing. How much gas must be ejected per second so that the rocket may have

initial upwards acceleration of magnitude $19.6m/s^2$? [Exhaust

speed of fuel = $980m/s$]

A. $240kgs^{-1}$

B. $60kgs^{-1}$

C. $120kgs^{-1}$

D. $20kgs^{-1}$

Answer:



[Watch Video Solution](#)

13. A 2kg toy car can move along an x axis. Graph shows force F_x , acting on the car which being at rest at time $t = 0$. The

velocity of the particle at $t = 10\text{s}$ is:

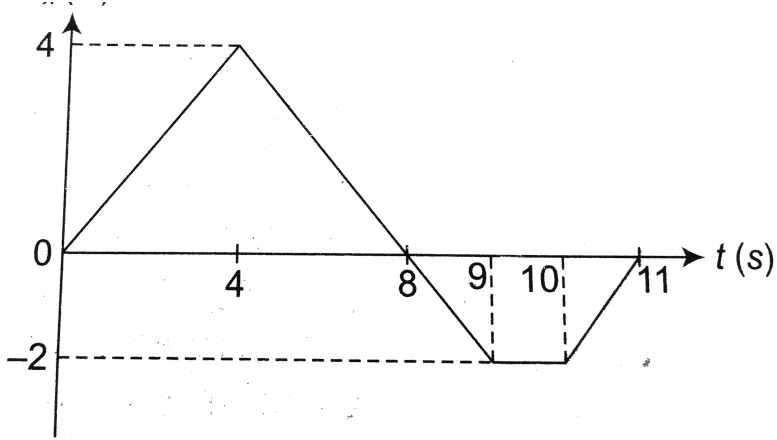

A. 2 m/s

B. 5 m/s

C. 6.5 m/s

D. 4.5 m/s

Answer:



Watch Video Solution

14. The displacement of a particle of mass 2kg moving in a straight line varies with times as $x = (2t^3 + 2)m$. Impulse of the force acting on the particle over a time interval between $t = 0$ and $t = 1$ s is

A. 10 N-s

B. 12 N-s

C. 8 N-s

D. 6 N-s

Answer:



Watch Video Solution

15. Ball 1 collides directly with another identical ball 2 at rest. Velocity of second ball becomes two times that of 1 after collision. Find the coefficient of restitution between the two balls?



Watch Video Solution

16. A particle of mass 1 kg is projected at an angle of 30° with horizontal with velocity $v = 40 \text{ m/s}$. The change in linear momentum of the particle after time $t = 1 \text{ s}$ will be ($g = 10 \text{ m/s}^2$)

A. 7.5 kg-m/s

B. 15 kg - m/s

C. 10 kg-m/s

D. $20 \text{ kg}\cdot\text{m/s}$

Answer:

 [Watch Video Solution](#)

17. Two blocks of masses 3kg and 6kg respectively are placed on a smooth horizontal surface. They are connected by a light spring of force constant $k = 200\text{N/m}$. Initially the spring is unstretched. The indicated velocities are imparted to the blocks. Find the maximum extension of the spring.

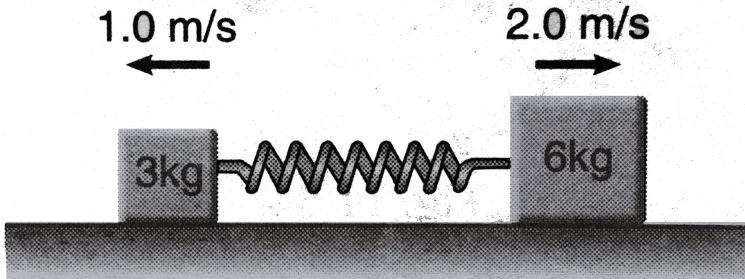

A. 30 cm

B. 25 cm

C. 20 cm

D. 15 cm

Answer:



Watch Video Solution

18. The centre of mass of a non uniform rod of length L , whose mass per unit length varies as $\rho = \frac{k \cdot x^2}{L}$ where k is a constant and x is the distance of any point from one end is (from the same end)

A. $\frac{3L}{4}$

B. $\frac{L}{8}$

C. $\frac{K}{L}$

D. $\frac{3K}{L}$

Answer:



Watch Video Solution

19. A particle of mass m is made to move with uniform speed u along the perimeter of a regular polygon of n sides. What is the magnitude of impulse applied by the particle at each corner of the polygon?

A. $2 mv \sin \frac{\pi}{2n}$

B. $mv \sin \frac{\pi}{2n}$

C. $m v \cos \frac{\pi}{2n}$

D. $2 mv \cos \frac{\pi}{2n}$

Answer:



Watch Video Solution

20. From a circular disc of radius R , a square is cut out with a radius as its diagonal. The center of mass of remaining portion is at a distance from the center)

A. $\frac{R}{\pi - 2}$

B. $\frac{R}{\pi}$

C. $\frac{R}{2(2\pi - 1)}$

D. $\frac{R}{2}$

Answer:



Watch Video Solution

21. A Force $F = (2\hat{i} + \hat{j} + 3\hat{k})$ N acts on a particle of mass 1 kg for 2 s . If initial velocity of particle is $u = (2\hat{i} + \hat{j})$ m/s . Speed of particle at the end of 2 s will be

A. 12 m/s

B. 6 m/s

C. 9 m/s

D. 4 m/s

Answer:



[Watch Video Solution](#)

22. A bullet is fired from a gun The force on a bullet is $F = 600 - 2 \times 10^5 t$ newton. The force reduces to zero just

when the bullet leaves barrel Find the impulse imparted to the bullet .

A. 8 N-s

B. 0.9 N-s

C. 1.8 N-s

D. 2.4 N-s

Answer:



[Watch Video Solution](#)

23. A uniform rod of length l is kept vertically on a rough horizontal surface at $x = 0$. It is rotated slightly and released . When the rod finally falls on the horizontal surface , the lower

end will remain at

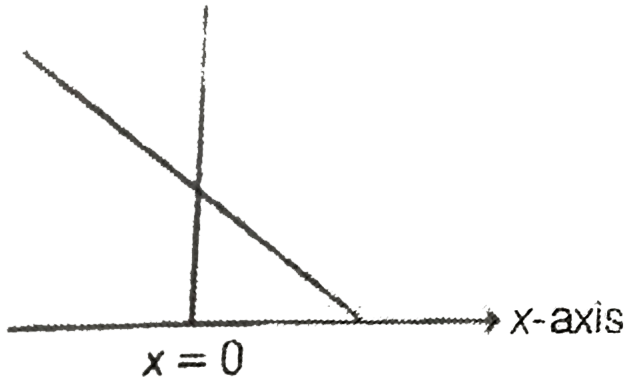

A. $x = 1/2$

B. $x > 1/2$

C. $x < 1/2$

D. $x = 0$

Answer:



Watch Video Solution

24. An object comprises of a uniform ring of radius R and its uniform chord AB (not necessarily made of the same material) as shown. Which of the following can not be the centre of mass of object

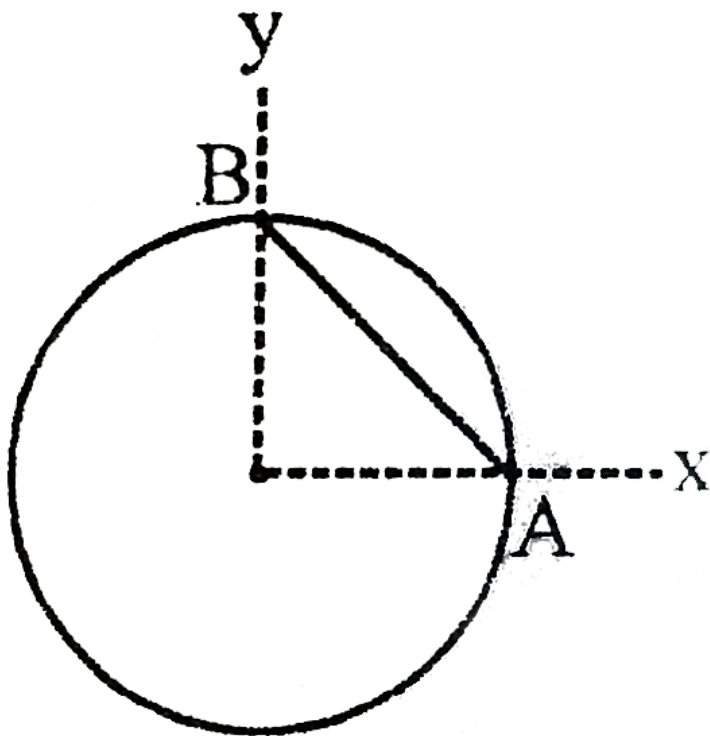

A. $(R/3, R/3)$

B. $(R/\sqrt{2}, R/\sqrt{2})$

C. $(R/4, R/4)$

D. None of these

Answer:



Watch Video Solution

25. A projectile of mass $3m$ explodes at highest point of its path. It breaks into three equal parts. One part retraces its path, the second one comes to rest. The range of the projectile was 100 m if no explosion would have taken place. The distance of the third part from the point of projection when it finally lands on the ground is -

A. 100 m

B. 50 m

C. 250 m

D. 300 m

Answer:



Watch Video Solution

26. Choose the correct option:

A metre rule, weighing 100 g rests on a table with a part projecting over the edge. Find the length of the part projecting out if a 5 g body hung at the end just tills the rule.

A. (a) 37.5 cm

B. (b) 26.8 cm

C. (c) 40.2 cm

D. (d) 47.6 cm

Answer:

[Watch Video Solution](#)

27. Four particle of masses $m_1 = 2m, m_2 = 4m, m_3 = m$ and m_4 are placed at four corners of a square. What should be the value of m_4 so that the centres of mass of all the four particle are exactly at the centre of the square ?

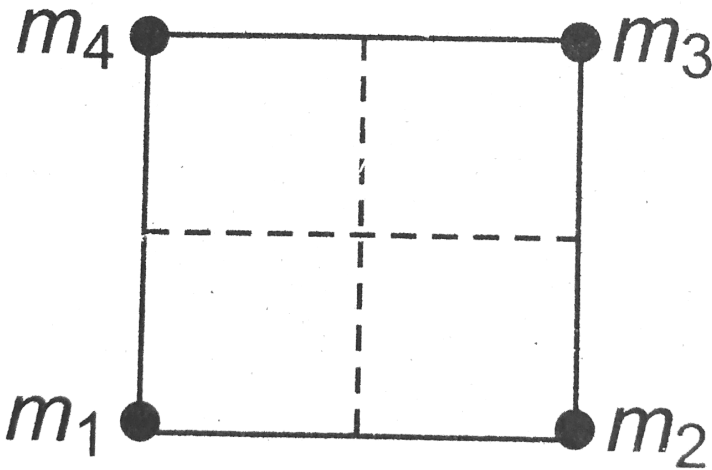

A. 2m

B. 8 m

C. 6 m

D. None of these

Answer:



[Watch Video Solution](#)

28. Mass is non - uniformly distributed on the circumference of a ring of radius a and centre at origin . Let b be the distance of centre of mass of the ring from origin. Then ,

A. $b = a$

B. $0 \leq b \leq a$

C. $b < a$

D. $b > a$

Answer:



Watch Video Solution

29. A man of mass 80 kg is riding on a small cart of mass 40 kg which is rolling along a level floor at a speed 2 m/s . He is running on the cart , so that his velocity relative to the cart is 3 m/s in the direction opposite to the motion of cart . What is the speed of the centre of the mass of the system ?

A. 1.5 m/s

B. 1 m/s

C. 3 m/s

D. Zero

Answer:



Watch Video Solution

30. Two smooth objects with a coefficient of restitution e , collides directly and bounce as shown .

Newton ' law of restitution gives

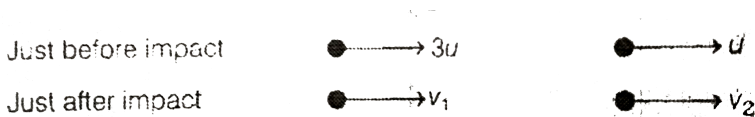

A. $e \times 4u = v_2 + v_1$

B. $e \times 2u = v_1 - v_2$

C. $e \times 2u = v_2 - v_1$

D. It cannot be applied as the masses are not known

Answer:



Watch Video Solution

31. Two billiard balls of same size and mass are in contact on a billiard table. A third ball of same mass and size strikes them symmetrically and remains at rest after the impact. Find the coefficient of restitution between the balls?

A. $\frac{1}{2}$

B. $\frac{1}{3}$

C. $\frac{2}{3}$

D. $\frac{3}{4}$

Answer:



Watch Video Solution

32. After perfectly inelastic collision between two identical balls moving with same speed in different directions, the speed of the combined mass becomes half the initial speed. Find the angle between the two before collision.

A. 60°

B. 45°

C. 120°

D. 30°

Answer:



[Watch Video Solution](#)

33. A ball strikes a horizontal floor at an angle $\theta = 45^\circ$ with the normal to floor. The coefficient of restitution between the

ball and the floor is $e = 1/2$. The fraction of its kinetic energy lost in the collision is.

A. $\frac{5}{8}$

B. $\frac{3}{8}$

C. $\frac{3}{4}$

D. $\frac{1}{4}$

Answer:



[Watch Video Solution](#)

34. A gardener waters the plants by a pipe of diameter 1 cm . The water comes out at the rate of 20 cc/s . The reactionary force exerted on the hand of the gardener is

A. 2.54×10^{-5} N

B. $1.62 \times 10^{-3} \text{ N}$

C. $5.1 \times 10^{-3} \text{ N}$

D. Zero

Answer:



[Watch Video Solution](#)

35. A bead can slide on a smooth straight wire and a particle of mass m attached to the bead by a light string of length L . The particle is held in contact with the wire and with the string taut and is then let fall. If the bead has mass $2m$ then when the string makes an angle θ with the wire, the bead will have

slipped a distance.

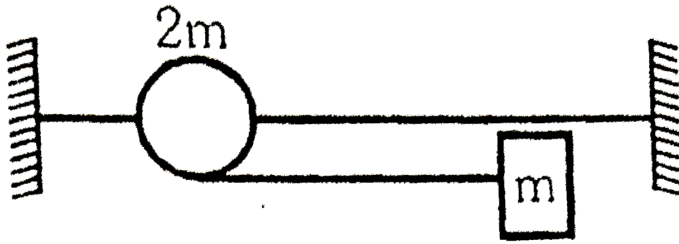

A. $L(1 - \cos\theta)$

B. $\frac{L}{2}(1 - \cos\theta)$

C. $\frac{L}{3}(1 - \cos\theta)$

D. $\frac{L}{6}(1 - \cos\theta)$

Answer:



Watch Video Solution

36. A man of mass m moves with a constant speed on a plank of mass M and length l kept initially at rest on a frictionless

horizontal surface, from one end to the other in time t . The speed of the plank relative to ground while man is moving, is

A. $\frac{L}{t} \left(\frac{M}{m} \right)$

B. $\frac{L}{t} \left(\frac{m}{M + m} \right)$

C. $\frac{L}{t} \left(\frac{M}{M - m} \right)$

D. None of these

Answer:



Watch Video Solution

37. Two particles of equal mass ' m ' are projected from the ground with speed v_1 and v_2 at angles θ_1 and θ_2 at the same times as shown in figure. The centre of mass of the two

particles.

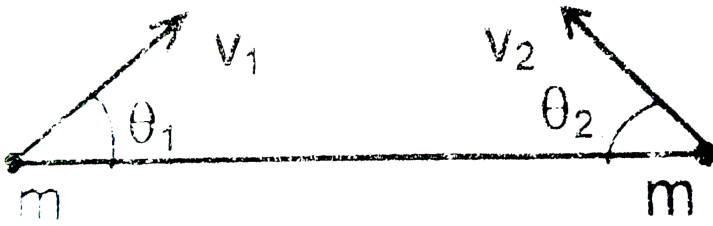

- A. will move in a parabolic path for any values of v_1, v_2, θ_1 and θ_2
- B. can move in a vertical line
- C. can move in horizontal line
- D. will move in a straight line for any value of v_1, v_2, θ_1 and θ_2

Answer:



Watch Video Solution

38. Two blocks of masses 2 kg and 1 kg respectively are tied to the ends of a string which passes over a light frictionless pulley . The masses are held at rest at the same horizontal level and then released . The distance traversed by centre of mass in 2 s is ($g = 10 \text{ m/s}^2$)

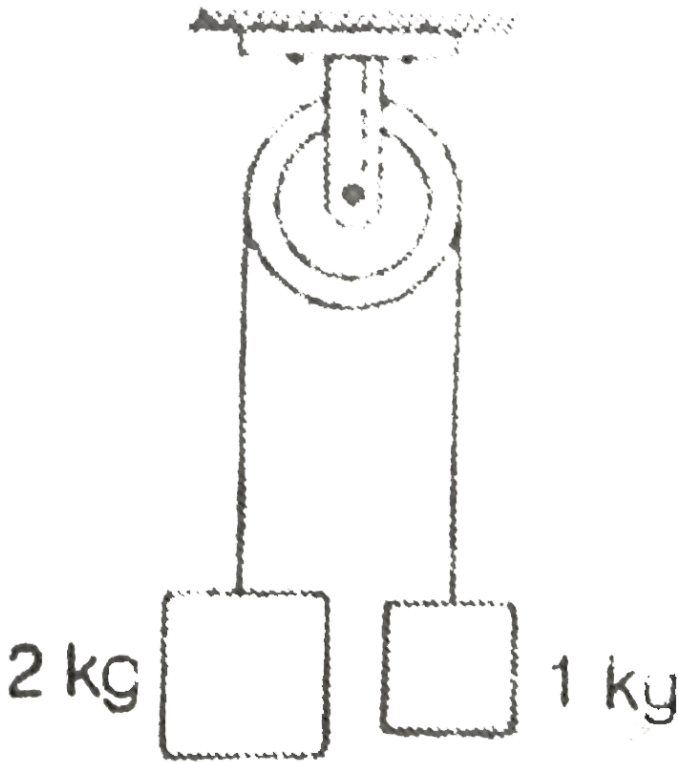

A. 1.42 m

B. 2.22 m

C. 3.12 m

D. 3.33 m

Answer:



[Watch Video Solution](#)

39. A boy of mass 60kg is standing over a platform of mass 40kg placed over a smooth horizontal surface. He throws a stone of mass 1kg with velocity $v = 10\text{m/s}$ at an angle of 45° with respect to the ground. Find the displacement of the platform (with boy) on the horizontal surface when the stone lands on the ground. Take $g = 10\text{m/s}^2$.

A. 25 cm

B. 5 cm

C. 10 cm

D. 50 cm

Answer:



Watch Video Solution

40. A particle of mass m moving with a speed v hits elastically another stationary particle of mass $2m$ on a smooth horizontal circular tube of radius r . Find the time when the next collision will take place?

A. $\frac{2\pi r}{v}$

B. $\frac{4\pi r}{v}$

C. $\frac{3\pi r}{2v}$

D. $\frac{\pi r}{v}$

Answer:



Watch Video Solution

41. A particle of mass 100 g moving at an initial speed u collides with another particle of same mass kept initially at rest. If the total kinetic energy becomes 0.2 J after the collision what could be minimum and the maximum value of u .

A. minimum value of v is 2 m/s

B. maximum value of v is 4 m/s

C. minimum value of v is 3 m/s

D. maximum value of v is 6 m/s

Answer:



Watch Video Solution

42. A sphere is moving with velocity vector $2\hat{i} + 2\hat{j}$ immediately before it hits a vertical wall. The wall is parallel to \hat{j} and the coefficient of restitution of the sphere and the wall is $e = \frac{1}{2}$.

Find the velocity of the sphere after it hits the wall?

A. $\hat{i} - \hat{j}$ B. $-\hat{i} + 2\hat{j}$ C. $-\hat{i} - \hat{j}$ D. $2\hat{i} - \hat{j}$

A. $\hat{i} - \hat{j}$

B. $-\hat{i} + 2\hat{j}$

C. $-\hat{i} - \hat{j}$

D. $2\hat{i} - \hat{j}$

Answer:



[Watch Video Solution](#)

43. In one dimensional elastic collision of equal masses, the velocities are interchanged. Can velocities in one dimensional collision be interchanged if the masses are not equal?



[Watch Video Solution](#)

44. Infinite number of bricks are placed one over the other as shown in the figure. Each succeeding brick having half the length and breadth of its preceding brick and the mass of each succeeding bricks being $(1/4)^{th}$ of the preceding one. Taking 'O' as the origin, the x coordinate of centre of mass of the

system of bricks is at

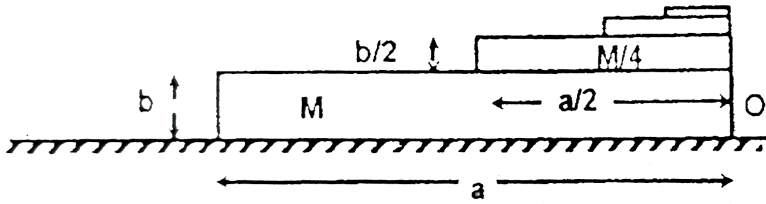

- A. $-\frac{a}{7}$
- B. $\frac{3a}{7}$
- C. $-\frac{3a}{7}$
- D. $-\frac{2a}{7}$

Answer:

 [Watch Video Solution](#)

45. A ball of mass m moving vertically down, collides with inclined surface of the wedge. After the collision, wedge starts

moving in horizontal direction with velocity v_0 . If all the surfaces are smooth then impulse applied by wedge on the ball during collision is given by

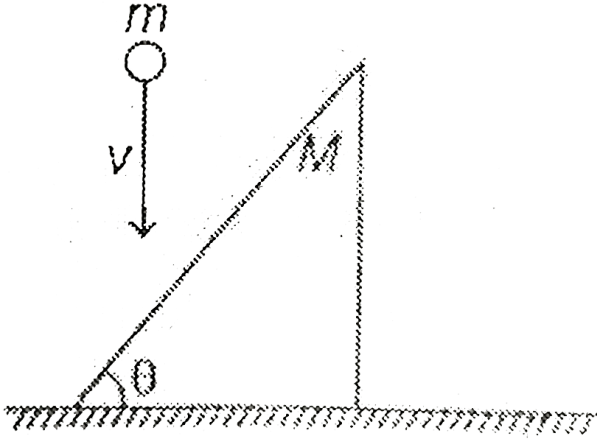

A. $Mv_0\sin\theta$

B. $Mv_0\cos\theta$

C. $\frac{Mv_0}{\sin\theta}$

D. $\frac{Mv_0}{\cos\theta}$

Answer:



Watch Video Solution

46. Block A is hanging from a vertical spring and is at rest. Block B strikes the block A with velocity v and sticks to it. Then the value of v for which the spring just attains natural length is

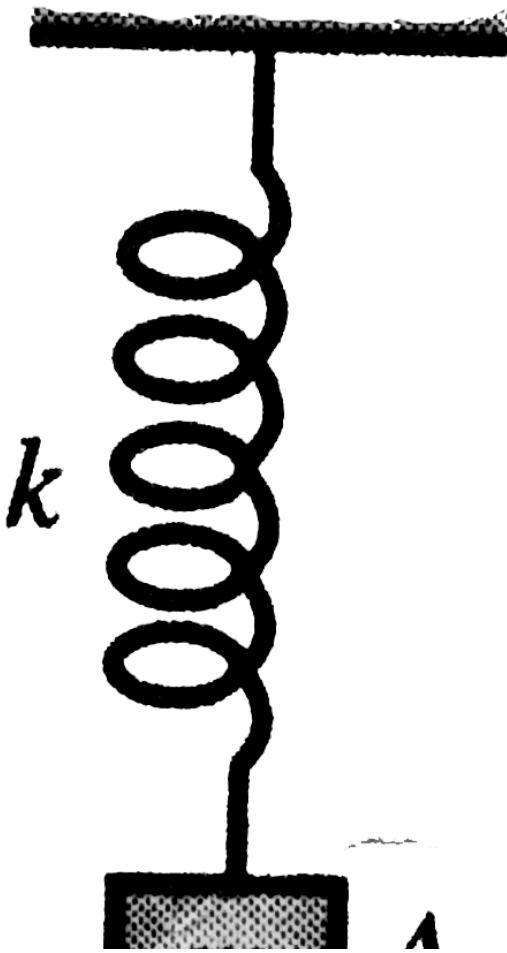

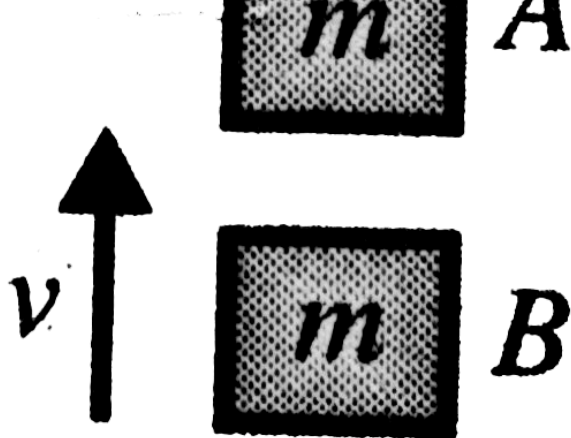

A. $\sqrt{\frac{5mg^2}{k}}$

B. $\sqrt{\frac{6mg^2}{k}}$

C. $\sqrt{\frac{4mg^2}{k}}$

D. $\sqrt{\frac{8mg^2}{k}}$

Answer:



Watch Video Solution

47. Choose the correct option:

Three blocks of identical masses are placed on a frictionless table as shown . The centre block is at rest , whereas the other two blocks are moving directly towards the stationary block with identical speed v . The centre block is initially closer to the left block than the right one . All collisions are elastic . After long time , which of the following is true .



- A. (a) The centre block is moving towards left
- B. (b) The centre block is at rest somewhere to the left of its initial position .
- C. (c) The centre block is at rest at its initial position

D. (d) The centre block is at rest somewhere to the right of its initial position .

Answer:



[Watch Video Solution](#)

48. A stream of water droplets, each of mass $m = 0.001\text{kg}$ are fired horizontally at a velocity of 10m/s towards a vertical steel plate where they collide. The droplets are spaced equidistant with a spacing of 1cm . What is approximate average force exerted on the plate by the water droplets. (Assuming that they do not rebound after collision.)

A. 10 N

B. 100 N

C. 1 N

D. 0.1 N

Answer:



Watch Video Solution

49. Seven particles are placed at the seven corners of a cube of side ' a ' (except at origin) . The mass of each particle is ' m ' . The

centre of mass of the system is

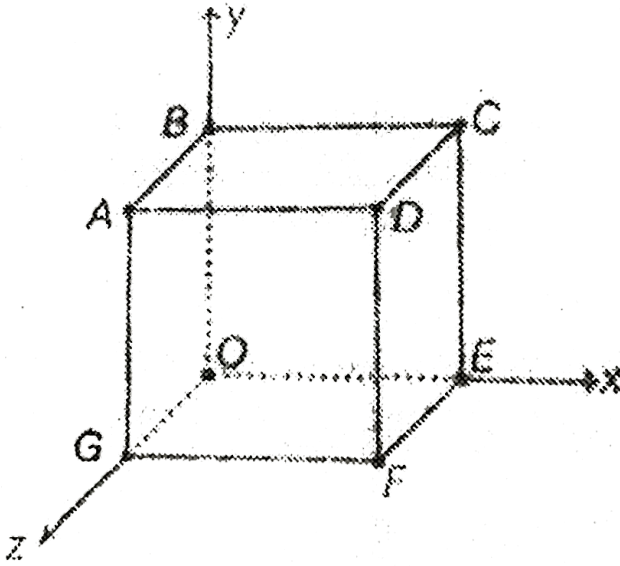

A. $\frac{a}{\sqrt{3}} \hat{i} + \frac{a}{\sqrt{3}} \hat{j} + \frac{a}{\sqrt{3}} \hat{k}$

B. $\frac{a}{3} \hat{i} + \frac{a}{5} \hat{j} + \frac{a}{3} \hat{k}$

C. $\frac{4a}{7} \hat{i} + \frac{4a}{7} \hat{j} + \frac{4a}{7} \hat{k}$

D. $\frac{5a}{7} \hat{i} + \frac{5a}{7} \hat{j} + \frac{5a}{7} \hat{k}$

Answer:



Watch Video Solution

1. As shown in the figure a body of mass m moving vertically with speed 3 m/s hits a smooth fixed inclined plane and rebounds with a velocity v_f in the horizontal direction. If angle of plane with horizontal is 30° , the velocity v_f will be

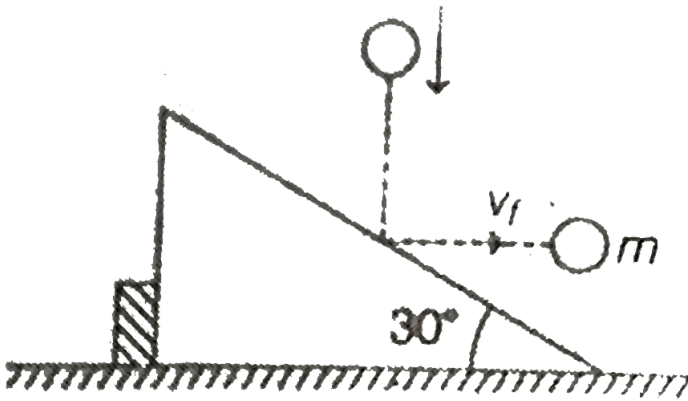

A. 3 m/s

B. $\sqrt{3} \text{ m/s}$

C. $1/\sqrt{3} \text{ m/s}$

D. 2 m/s

Answer:



Watch Video Solution

2. A hemisphere of radius R and mass $4m$ is free to slide with its base on a smooth horizontal table. A particle of mass m is placed on the top of the hemisphere. The angular velocity of the particle relative to centre of hemisphere at an angular displacement θ when velocity of hemisphere has become v is

A. $\frac{5v}{R\cos\theta}$

B. $\frac{2v}{R\cos\theta}$

C. $\frac{3v}{R\sin\theta}$

D. $\frac{5v}{R\sin\theta}$

Answer:



Watch Video Solution

3. Two blocks A and B of mass m and $2m$ respectively are connected by a light spring of force constant k . They are placed on a smooth horizontal surface. Spring is stretched by a length x and then released. Find the relative velocity of the blocks when the spring comes to its natural length

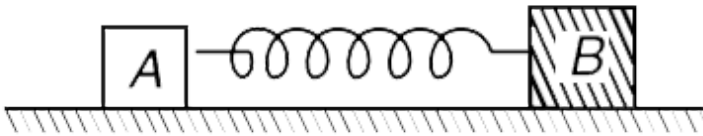

A. $\left(\sqrt{\frac{3k}{2m}}\right)x$

B. $\left(\sqrt{\frac{2k}{3m}}\right)x$

C. $\sqrt{\frac{2kx}{m}}$

D. $\sqrt{\frac{3km}{2x}}$

Answer:

 [Watch Video Solution](#)

4. A ball of mass m approaches a heavy wall of mass M with speed 4 m/s along the normal to the wall. The speed of wall before collision is 1 m/s towards the ball. The ball collides elastically with the wall. What can you say about the speed of the ball after collision? Will it be slightly less than or slightly higher than 6 m/s ?

- A. 5 m/s away from the wall
- B. 9 m/s away from the wall
- C. 3 m/s away from the wall

D. 6 m/s away from the wall

Answer:



Watch Video Solution

5. A tennis ball bounces down a flight of stairs, striking each step in turn and rebounding to half to height of the step. The coefficient of restitution is

A. $\frac{1}{2}$

B. $\frac{1}{\sqrt{2}}$

C. $\frac{1}{4}$

D. 1

Answer:

6. A particle of mass m_1 moves with speed v and collides head on with a stationary particles of mass m_2 . The first particle continues to move in the same direction

If $\frac{m_1}{m_2}$ is (e = coefficient of restitution)

A. $= e$

B. $> e$

C. $< e$

D. $> e^2$

Answer:

7. A gun fires a bullet. The barrel of the gun is inclined at an angle of 45° with horizontal. When the bullet leaves the barrel it will be travelling at an angle greater than 45° with the horizontal. Is this statement true or false?

A. 45°

B. less than 45°

C. more than 45°

D. zero

Answer:



Watch Video Solution

8. A small block of superdense material has a mass $\frac{M}{3}$, where M is the mass of earth. It is released from rest from a height h ($h \ll$ radius of earth) from the surface of earth. The speed of the block at a height $\frac{h}{2}$ is

A. \sqrt{gh}

B. $\frac{\sqrt{(3gh)}}{2}$

C. $\sqrt{\frac{2gh}{3}}$

D. $\sqrt{2gh}$

Answer:



Watch Video Solution

9. A block of mass m is pushed towards a movable wedge of mass nm and height h , with a velocity u . All surfaces are smooth. The minimum value of u for which the block will reach the top of the wedge is

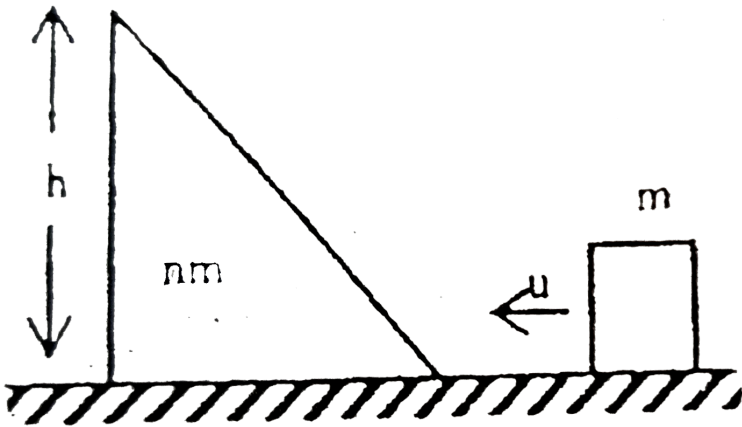

[▶ Watch Video Solution](#)

10. A block of mass m slides down on inclined wedge of same mass m as shown in figure . Friction is absent everywhere .

Acceleration of centre of mass of the block and wedge is

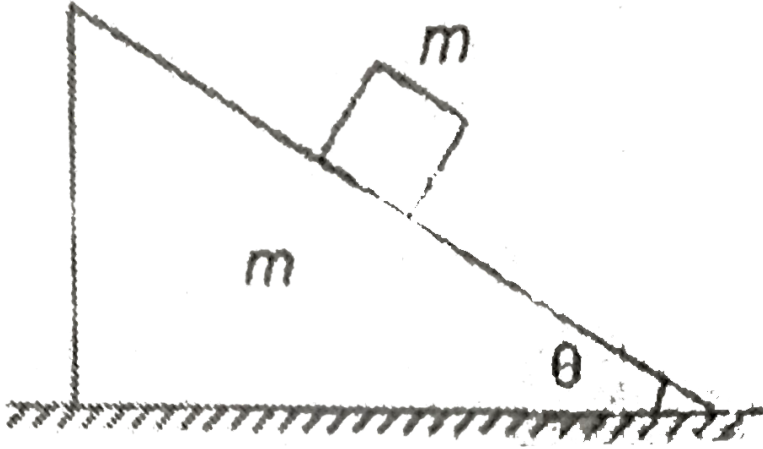

A. zero

B. $\frac{g \sin^2 \theta}{(1 + \sin^2 \theta)}$

C. $\frac{g \cos^2 \theta}{(1 + \sin^2 \theta)}$

D. $\frac{g \sin \theta}{(1 + \cos \theta)}$

Answer:



Watch Video Solution

11. A block A slides over another block B which is placed over a smooth inclined plane as shown in figure . The coefficient of friction between the two blocks A and B is μ . Mass of block B is two times the mass of block A . The acceleration of the centre of mass of two blocks is

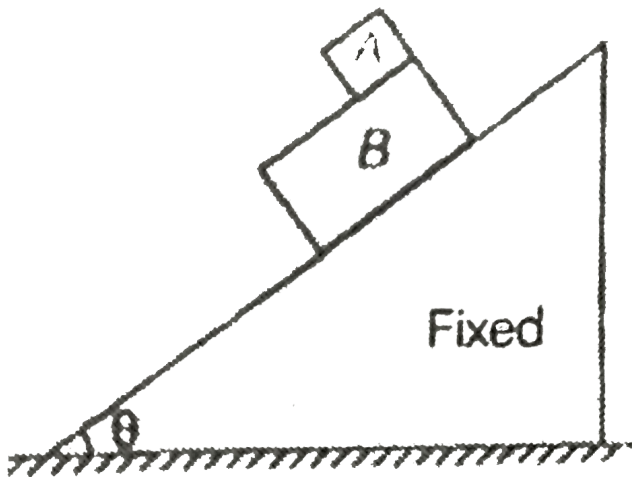

A. $g \sin \theta$

B. $\frac{g \sin \theta - \mu g \cos \theta}{3}$

C. $\frac{g \sin \theta}{3}$

D. $\frac{2g\sin\theta - \mu g\cos\theta}{3}$

Answer:



Watch Video Solution

12. The momentum of a particle is $P = A + Bt^2$. Where , A and B are constant perpendicular vectors . The force acting on the particle when its acceleration is at 45° with its velocity is

(a) $2\sqrt{\frac{A}{B}}B$ (b) $2B$ (c) zero (d) $2A$

A. $2\sqrt{\frac{A}{B}}B$

B. $2B$

C. zero

D. $2A$

Answer:



Watch Video Solution

13. Velocity of centre of mass of two particles is v and the sum of masses of two particles is m . Kinetic energy of the system

(A) will be equal to $\frac{1}{2}mv^2$ (B) will always be less than $\frac{1}{2}mv^2$

(C) will be greater than or equal to $\frac{1}{2}mv^2$ (D) will always be greater than $\frac{1}{2}mv^2$

A. will be equal to $\frac{1}{2}mv^2$

B. will always be less than $\frac{1}{2}mv^2$

C. will be greater than or equal to $\frac{1}{2}mv^2$

D. will always be greater than $\frac{1}{2}mv^2$

Answer:



14. Two blocks A and B of equal masses are attached to a string passing over a smooth pulley fixed to a wedge as shown in figure. Find the magnitude of acceleration of centre of mass of the two blocks when they are released from rest. Neglect friction.

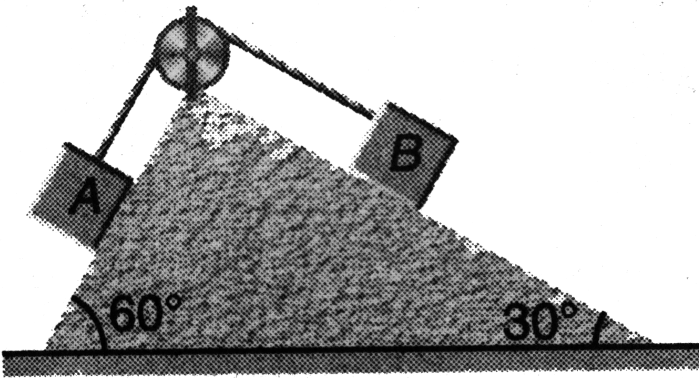

Fig. 11.23

A. $\left(\frac{\sqrt{3} - 1}{4\sqrt{2}} g \right)$

B. $(\sqrt{3} - 1)g$

C. $\frac{g}{2}$

D. $\left(\frac{\sqrt{3} - 1}{\sqrt{2}} g \right)$

Answer:



Watch Video Solution

15. A rope thrown over a pulley has a ladder with a man of mass m on one of its ends and a counter balancing mass M on its other end. The man climbs with a velocity v_r relative to ladder. Ignoring the masses of the pulley and the rope as well as the friction on the pulley axis, the velocity of the centre of mass of this system is:

A. $\frac{m}{M} v_r$

B. $\frac{m}{2M} v_r$

C. $\frac{M}{m}v_r$

D. $\frac{2M}{m}v_r$

Answer:



Watch Video Solution

16. Two particles of equal mass have velocities $\vec{v}_1 = 2\hat{i} = m/s^{-1}$ and $\vec{v}_2 = 2\hat{j}m/s^{-1}$. First particle has an acceleration $\vec{a}_1 = (3\hat{i} + 3\hat{j})ms^{-2}$ while the acceleration of the other particle is zero. The centre of mass of the two particles moves in a path of.

A. circle

B. parabola

C. staright line

D. ellipse

Answer:



Watch Video Solution

17. A particle of mass $2m$ is projected at an angle of 45° with horizontal with a velocity of $20\sqrt{2}m/s$. After $1s$ explosion takes place and the particle is broken into two equal pieces. As a result of explosion one part comes to rest. Find the maximum height attained by the other part. Take $g = 10m/s^2$.

A. 50 m

B. 25 m

C. 40 m

D. 35 m

Answer:



Watch Video Solution

18. Choose the correct option:

A system of two blocks A and B and a wedge C are released from rest as shown in figure . Masses of the blocks and the wedge are m , $2m$ and $2m$ respectively . The displacement of wedge C when block B slides down the plane a distance 10 cm is

(neglect friction)

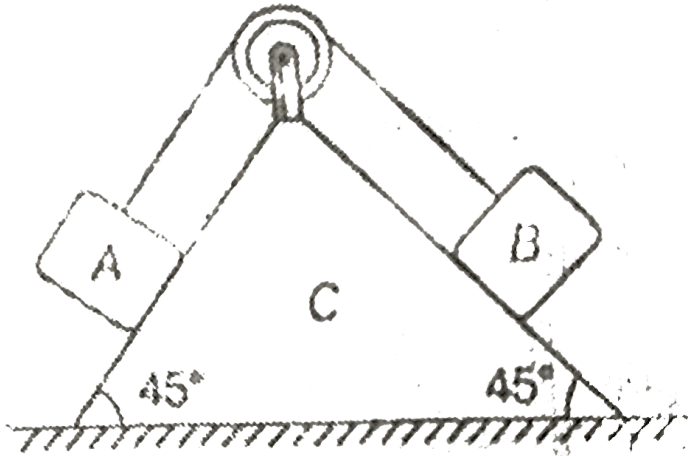

A. (a) $5\sqrt{2}$ cm

B. (b) $3\sqrt{2}$ cm

C. (c) 4 cm

D. (d) $\frac{5}{\sqrt{2}}$ cm

Answer:



Watch Video Solution

19. A small sphere of radius R is held against the inner surface of larger sphere of radius $6R$ (as shown in figure). The masses of large and small spheres are $4M$ and M respectively. This arrangement is placed on a horizontal table. There is no friction between any surfaces of contact. The small sphere is now released. Find the coordinates of the centre of the large sphere, when the smaller sphere reaches the other extreme position.

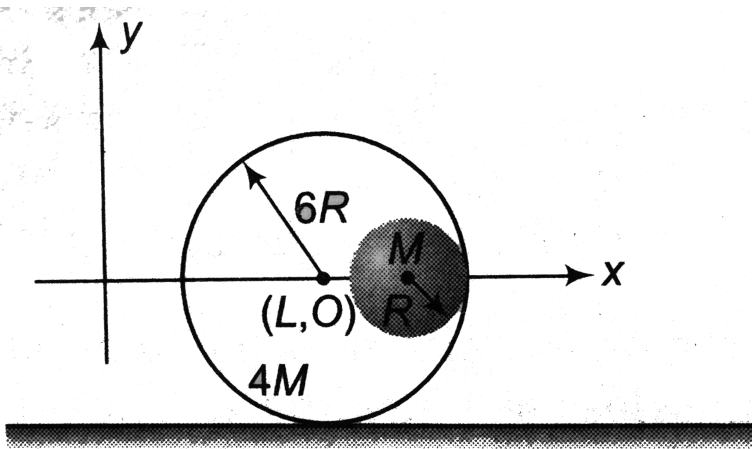

A. R

B. 2R

C. 3R

D. 4R

Answer:



Watch Video Solution

20. A block of mass m slides over a smooth wedge of mass M which is placed over a rough horizontal surface . The centre of mass of the system will move towards left

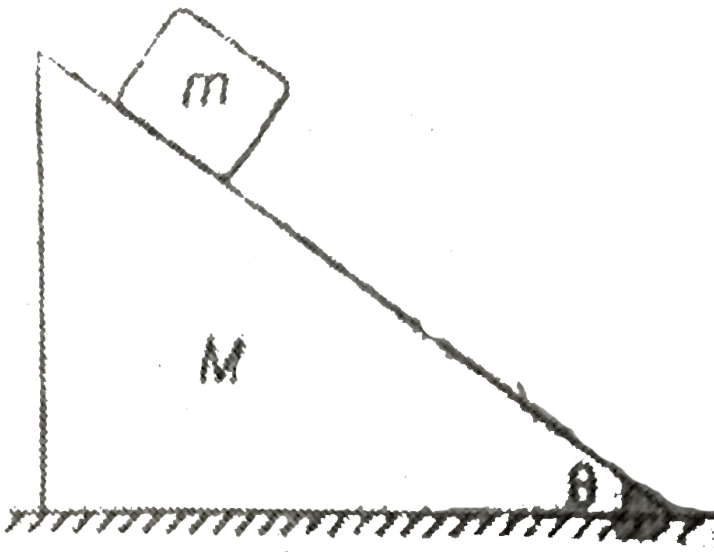

Here μ = coefficient of friction between the wedge and the ground .

- A. if $mg \cos \theta \sin \theta > \mu(M + m)g$
- B. if $mg \sin \theta > \mu Mg$
- C. if $mg \cos \theta \sin \theta > \mu Mg$
- D. None of the above

Answer:



21. Two particles A and B of equal mass m are attached by a string of length $2l$ and initially placed over a smooth horizontal table in the position shown in fig. particle B is projected across the table with speed u perpendicular to AB as shown in the figure. find the velocities of each particle after the string

becomes taut and the magnitude of the impulse tension.

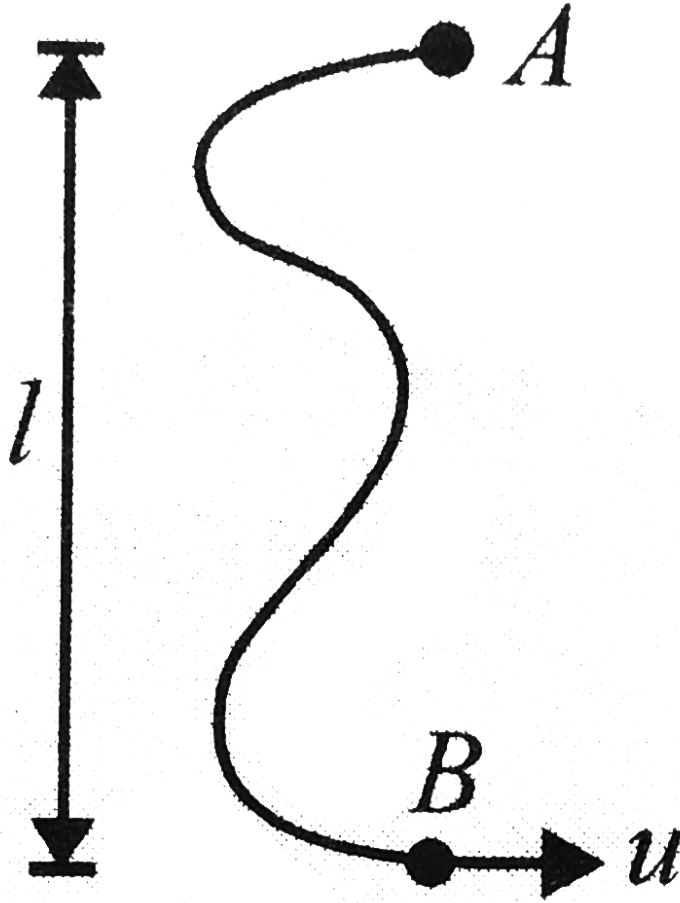

A. $\frac{u\sqrt{3}}{4}$

B. $u\sqrt{3}$

C. $\frac{u\sqrt{3}}{2}$

D. $\frac{u}{2}$

Answer:



Watch Video Solution

22. A mass m rests on a horizontal table. It is attached to a light inextensible string which passes over a smooth pulley and carries a mass m at the other end. If the mass m is raised vertically through a distance h and is then dropped, what is the

speed with which the mass $2m$ begins to rise?

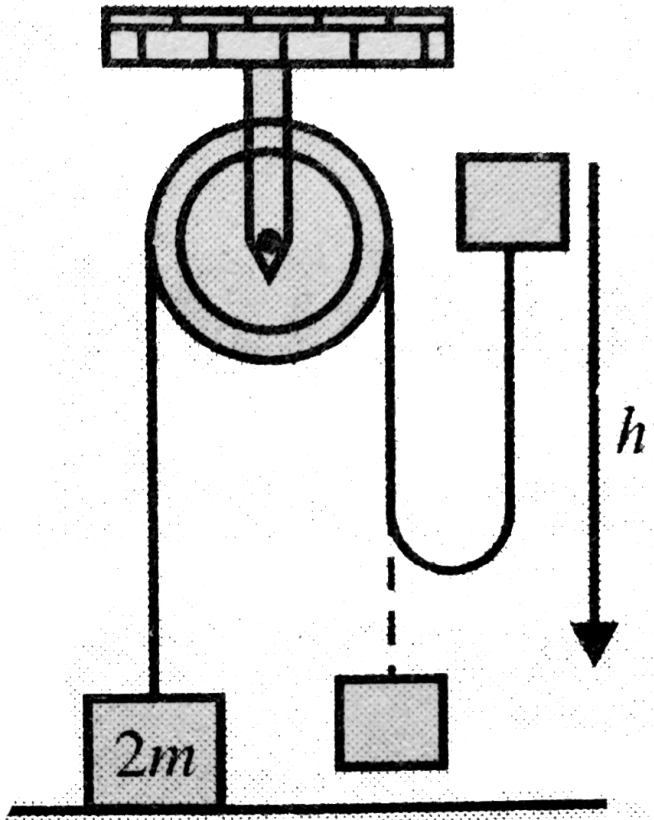

A. $\sqrt{2gh}$

B. $\frac{\sqrt{2gh}}{3}$

C. $\frac{\sqrt{gh}}{2}$

D. \sqrt{gh}

Answer:

 [Watch Video Solution](#)

23. Two identical balls A and B are released from the position shown in Fig. They collide elastically with each other on the horizontal portion. The ratio of heights attained by A and B after collision is (neglect friction)

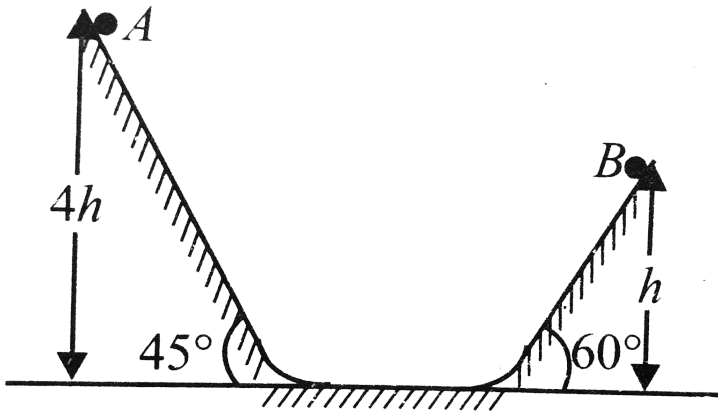

A. 1 : 4

B. 2: 1

C. 4: 13

D. 2: 5

Answer:



[Watch Video Solution](#)

24. A small block of mass M moves with velocity 5 m/s towards an another block of same mass M placed at a distance of 2 m on a rough horizontal surface . Coefficient of friction between the blocks and ground is 0.25 . Collision between the two blocks is elastic , the separation between the blocks , when both of them come to rest , is ($g = 10 \text{ m} / \text{s}^2$)

A. 3 m

B. 4 m

C. 2 m

D. 1.5 m

Answer:



[Watch Video Solution](#)

25. A particle of mass m collides with a stationary particle and continues to move at an angle of 45° with respect to the original direction . The second particle also recoils at an angle of 45° to this direction . The mass of the second particle is (collision is elastic)

A. m

B. $\sqrt{2}m$

C. $\frac{m}{\sqrt{2}}$

D. $\frac{m}{2}$

Answer:



Watch Video Solution

26. A gun fires a shell and recoils horizontally . If the shell travels along the barrel with speed v , the ratio of speed with which the gun recoils if (i) the barrel is horizontal (ii) inclined at an angle of 30° with horizontal is

A. 1

B. $\frac{2}{\sqrt{3}}$

C. $\frac{\sqrt{3}}{2}$

D. $\frac{1}{2}$

Answer:



Watch Video Solution

27. A body of mass m_0 is placed on a smooth horizontal surface . The mass of the body is decreasing exponentially with disintegration constant , λ . Assuming that the mass is ejected backwards with a relative velocity u . If initially the body was at rest , the speed of body at time t is

A. $ue^{\lambda t}$

B. $u\lambda t$

C. $ue^{-\lambda t}$

D. $u(1 - e^{-\lambda t})$

Answer:



[Watch Video Solution](#)

28. A balloon has 2 g of air . A small hole is pierced into it . The air comes out with relative velocity 4 m/s . If the balloon shrinks completely in 2.5 s , the average force acting on the balloon is

A. $0.008N$

B. $0.0032 N$

C. $8 N$

D. $3.2 N$

Answer:



[Watch Video Solution](#)

29. In a one-dimensional collision between two identical particles. A and B, B is stationary and A has momentum p before impact. During impact, B gives an impulse J to A. Find the coefficient of restitution between A and B?

A. $\frac{2J}{P} - 1$

B. $\frac{2J}{P} + 1$

C. $\frac{J}{P} + 1$

D. $\frac{J}{P} - 1$

Answer:



Watch Video Solution

30. Two particles one of mass m and the other of mass $2m$ are projected horizontally towards each other from the same level above the ground with velocities 10 m/s and 5 m/s respectively. They collide in air and stick to each other. The distance from A, where the combined mass finally land is

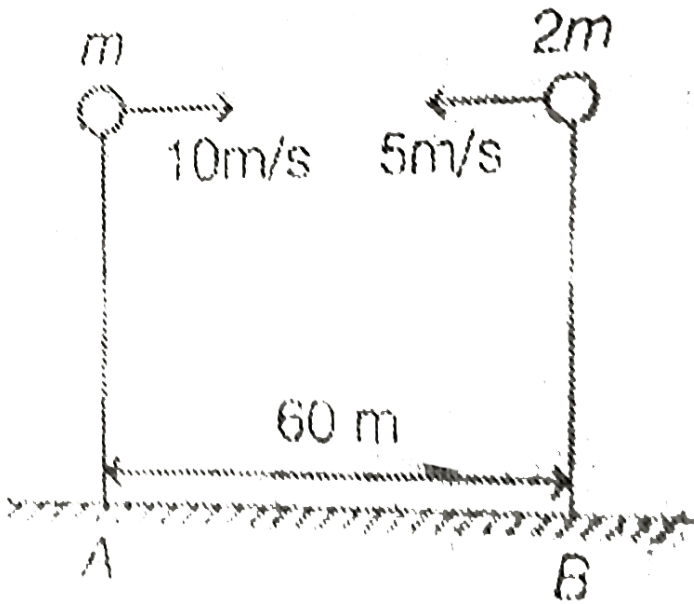

A. 40 m

B. 20 m

C. 30 m

D. 45 m

Answer:



[Watch Video Solution](#)

31. A ball A is falling vertically downwards with velocity v_1 . It strikes elastically with a wedge moving horizontally with velocity v_2 as shown in figure . What must be the ratio $\frac{v_1}{v_2}$, so that the ball bounces back in vertically upward direction

relative to the wedge

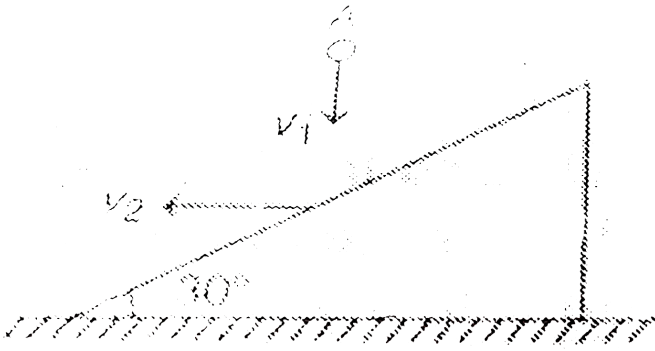

A. $\sqrt{3}$

B. $\frac{1}{\sqrt{3}}$

C. 2

D. $\frac{1}{2}$

Answer:



Watch Video Solution

32. A ball is projected from the point O with velocity 20 m/s at an angle of 60° with horizontal as shown in figure. At highest point of its trajectory it strikes a smooth plane of inclination 30° at point A. The collision is perfectly inelastic. The maximum height from the ground attained by the ball is ($g = 10 \text{ m/s}^2$)

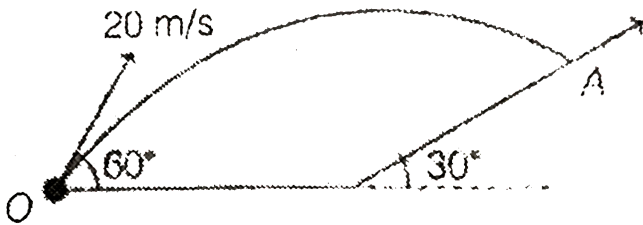

- A. 18.75m
- B. 15 m
- C. 22.5 m
- D. 20.25 m

Answer:



Watch Video Solution

33. A bullet of mass 'm' moving with velocity 'u' passes through a wooden block of mass $M = nm$ as shown in figure. The block is resting on a smooth horizontal floor. After passing through the block, velocity relative to the block is

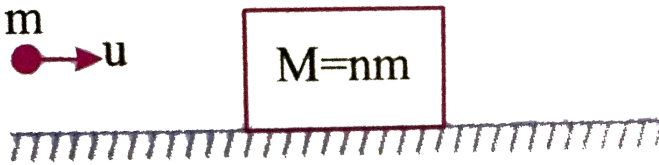

A. $\frac{(1+n)v - u}{n}$

B. $\frac{nv - u}{n + 1}$

C. $\frac{nu - v}{n + 1}$

D. $\frac{(1+n)v + u}{2n + 1}$

Answer:

34. A ball of mass m collides with the ground at an angle. With the vertical. If the collision lasts for time t , the average force exerted by the ground on the ball is : (e = coefficient of restitution between the ball and the ground)

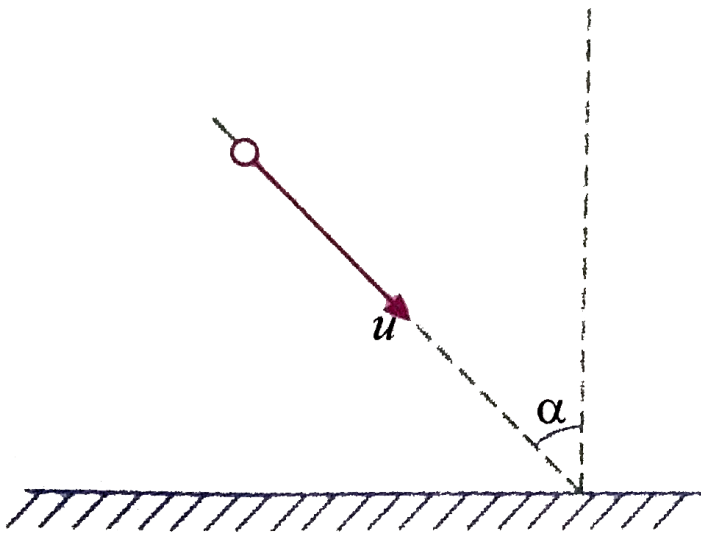

A. $\frac{emu \cos \alpha}{t}$

B. $\frac{2(1 + e)mu \cos \alpha}{t}$

C. $\frac{(1 + e)\mu \cos \alpha}{t}$

D. $\frac{e\mu}{t}$

Answer:



Watch Video Solution

35. A small ball falling vertically downward with constant velocity $2m/s$ strikes elastically an inclined plane moving with velocity $2m/s$ as shown in figure. The velocity of rebound of the ball with respect ground is

(A) $4m/s$

(B) $2\sqrt{5}m/s$

(C) $2\sqrt{2}m/s$

(D) $2m/s$

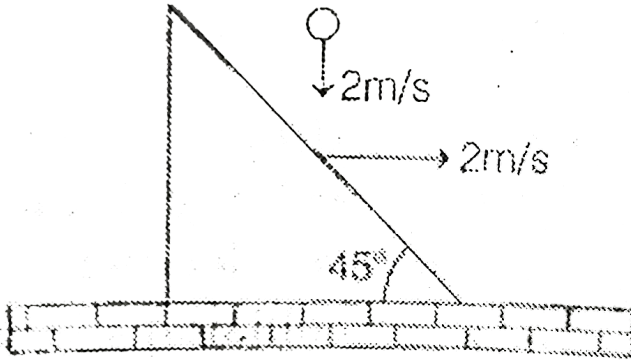

A. $4m/s$

B. $2\sqrt{5}m/s$

C. $2\sqrt{2}m/s$

D. $2m/s$

Answer:

 **Watch Video Solution**

36. Two blocks of mass m and $2m$ are kept on a smooth horizontal surface. They are connected by an ideal spring of force constant k . Initially the spring is unstretched. A constant force is applied to the heavier block in the direction shown in figure. Suppose at time t displacement of smaller block is x_1 then displacement of the heavier block at this moment would be

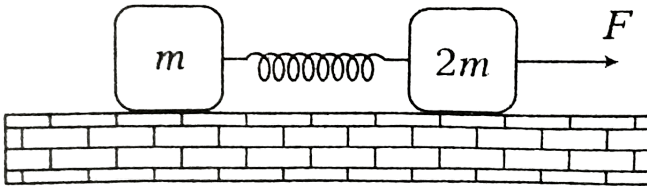

- A. $\frac{x}{2}$
- B. $\frac{Ft^2}{6m} + \frac{x}{3}$
- C. $\frac{x}{3}$
- D. $\frac{Ft^2}{4m} - \frac{x}{2}$

Answer:



Watch Video Solution

37. Blocks A and B shown in the figure are having equal masses m . The system is released from rest with the spring unstretched. The string between A and ground is cut, when there is maximum extension in the spring. The acceleration of

centre of mass of the two blocks at this instant is

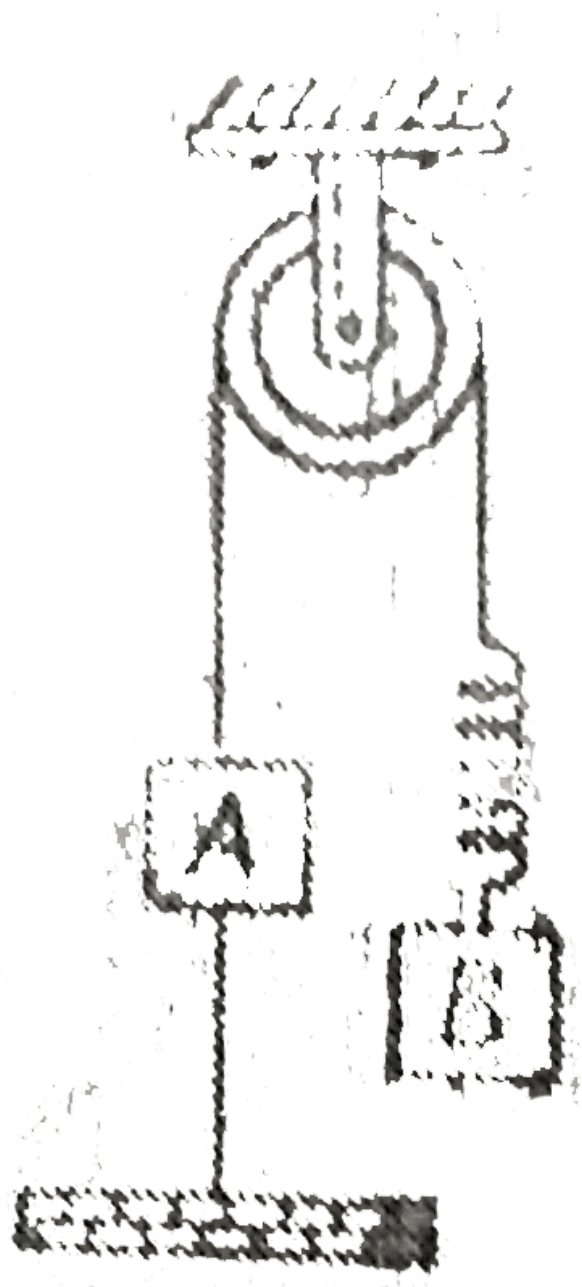

A. g

B. $\frac{g}{2}$

C. $2g$

D. zero

Answer:



[Watch Video Solution](#)

38. Both the blocks as shown in figure are given together a horizontal velocity towards right. The acceleration of the centre of mass of the system of block is ($m_A = 2m_B = 2kg$).

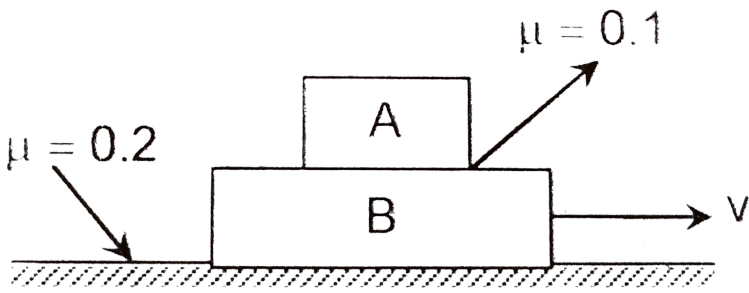

(A) zero (B) $5/3m/s^2$ (C) $7/3m/s^2$ (D) $2m/s^2$

A. zero

B. $5/3m/s^2$

C. $7/3m/s^2$

D. $2m/s^2$

Answer:



Watch Video Solution

39. A particle of mass $3m$ is projected from the ground at some angle with horizontal. Its horizontal range is R . At the highest point of its path it breaks into two pieces of masses m and $2m$ respectively. The smaller mass comes to rest. The larger mass finally falls at a distance x from the point of projection where x is equal to

(A) $\frac{4}{3}R$ (B) $\frac{3}{2}R$ (C) $\frac{5}{4}R$ (D) $2.5R$

A. $\frac{4}{3}R$

B. $\frac{3}{2}R$

C. $\frac{5}{4}R$

D. $2.5R$

Answer:



Watch Video Solution

40. A girl throws a ball with an initial velocity v at an angle 45° . The ball strikes a smooth vertical wall at a horizontal distance d from the girl and after rebound returns to her hands. What is the coefficient of restitution between wall and ball ? ($v^2 > dg$)

A. $v^2 - gd$

B. $\frac{gd}{v^2 - gd}$

C. $\frac{gd}{v^2}$

D. $\frac{v^2}{gd}$

Answer:



Watch Video Solution

41. Choose the correct answer:

A ball collides at B with velocity 10m/s at 30° with vertical.

There is a flag at A and a wall at C . Collision of ball with

ground is perfectly inelastic ($e = 0$) and that with wall is

elastic ($e = 1$). Given $AB = BC = 10\text{m}$. Find the time after

which ball will collide with the flag.

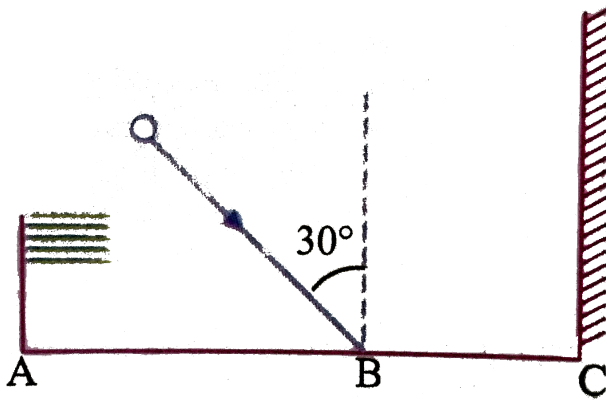

A. (a) 4

B. (b) 5

C. (c) 6

D. (d) ball will not collide with the flag

Answer:

 [Watch Video Solution](#)

42. Displacement-time graph of a particle moving in a straight line is as shown in figure. Mass of the particle is 2 kg. The total impulse imparted to the particle in a time interval from $t=0$ to $t=6$ s in N-s will be

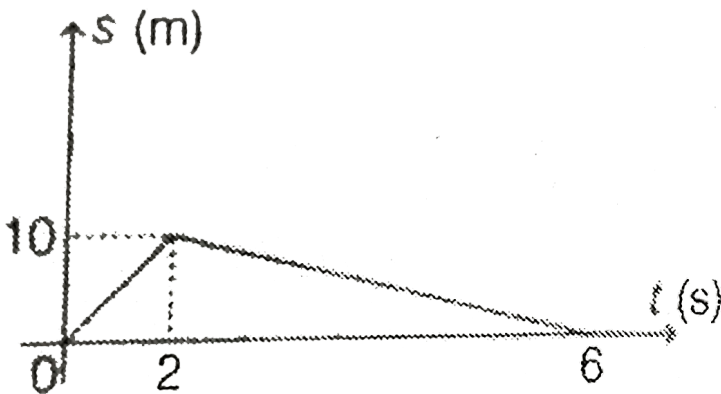

A. 30

B. 15

C. -30

D. -15

Answer:



[Watch Video Solution](#)

43. The lower end of a 4 m long uniform rod AB is pulled with constant speed $v=4 \text{ m/s}$. The speed of centre of mass of the

rod at $\theta = 60^\circ$ will be

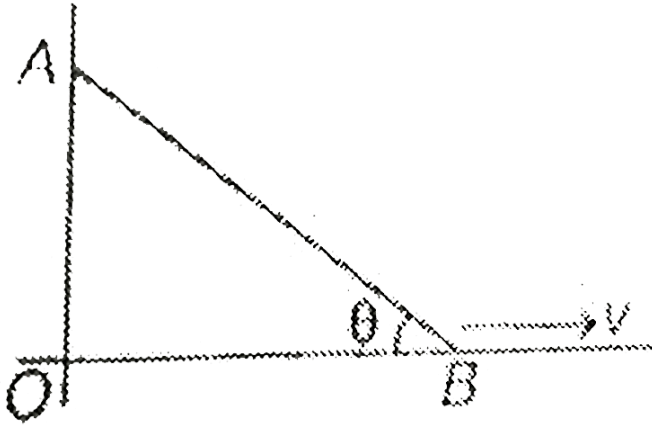

A. $\frac{4}{\sqrt{3}} m/s$

B. $2\sqrt{3} m/s$

C. $4 m/s$

D. $4\sqrt{3} m/s$

Answer:



Watch Video Solution

44. A rigid rod leans against a vertical wall (y-axis) as shown in figure. The other end of the rod is on the horizontal floor. Point A is pushed downwards with constant velocity. Path of the centre of the rod is

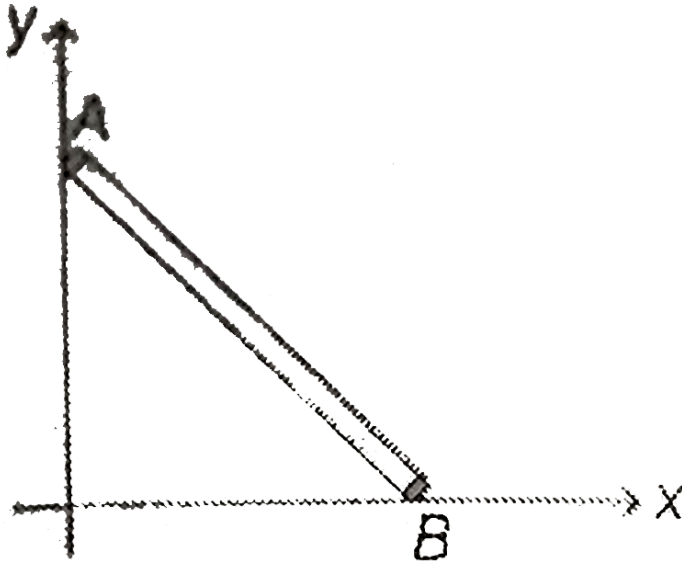

- A. a parabola
- B. an ellipse
- C. a circle of radius $l/2$ and centre at origin
- D. a circle of radius $l/2$ but centre not at origin

Answer:



Watch Video Solution

45. A bullet of mass m moving vertically upwards instantaneously with a velocity ' u ' hits the hanging block of mass ' m ' and gets embedded in it, as shown in the figure. The height through which the block rises after the collision.

(assume sufficient space above block) is:

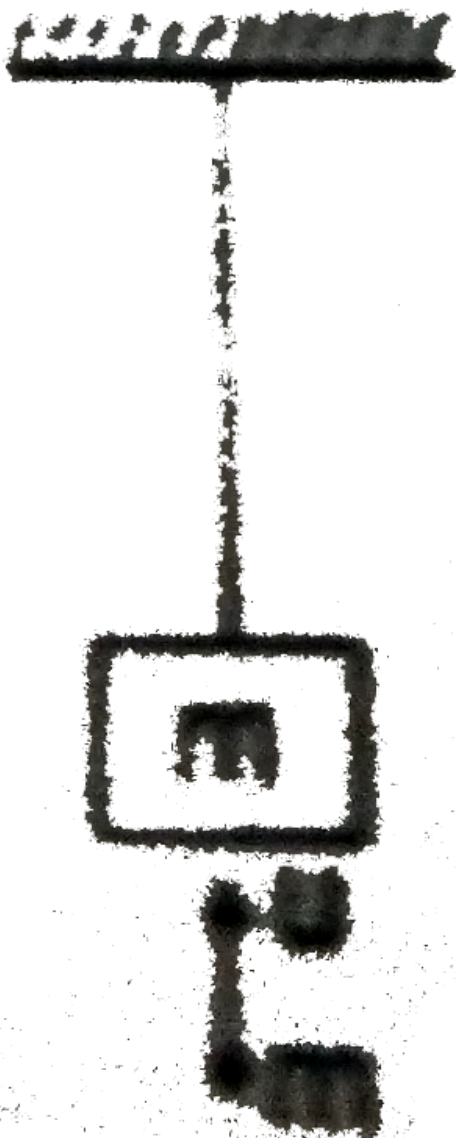

A. $u^2 / 2g$

B. u^2 / g

C. $u^2 / 8g$

D. $u^2 / 4g$

Answer:



Watch Video Solution

46. A super-ball of mass m is to bounce elastically back and forth between two rigid walls at a distance d from each other. Neglecting gravity and assuming the velocity of super-ball to be v_0 horizontally, the average force being exerted by the super-ball on each wall is

A. $\frac{1}{2} \frac{mv_0^2}{d}$

B. $\frac{mv_0^2}{d}$

C. $\frac{2mv_0^2}{d}$

D. $\frac{4mv_0^2}{d}$

Answer:



Watch Video Solution

47. A block of mass M with a semicircular of radius R , rests on a horizontal frictionless surface. A uniform cylinder of radius r and mass m is released from rest the top point A. The cylinder slips on the semicircular frictionless track. How far has the block moved when the cylinder reaches the bottom (point B) of the track ? How fast is the block moving when the cylinder

reaches the bottom of the track?

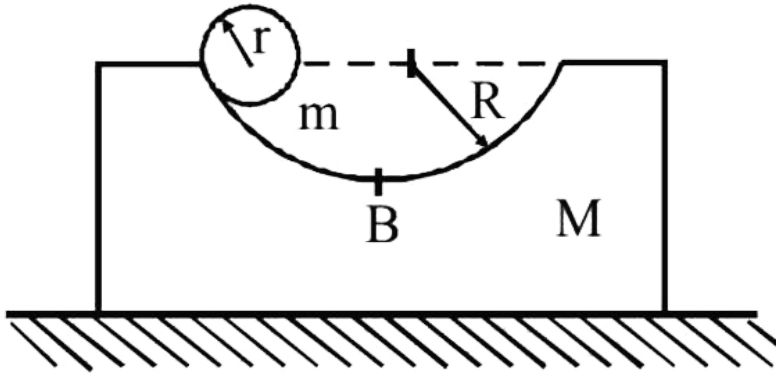

- A. $\frac{M(R - r)}{M + m}$
- B. $\frac{m(R - r)}{M + m}$
- C. $\frac{(M + m)R}{M}$

D. None of these

Answer:



Watch Video Solution

48. A block of mass M with a semicircular track of radius R , rests on a horizontal frictionless surface. A uniform cylinder of radius r and mass m is released from rest at the top point A. The cylinder slips on the semicircular frictionless track. How far has the block moved when the cylinder reaches the bottom (point B) of the track? How fast is the block moving when the cylinder reaches the bottom of the track?

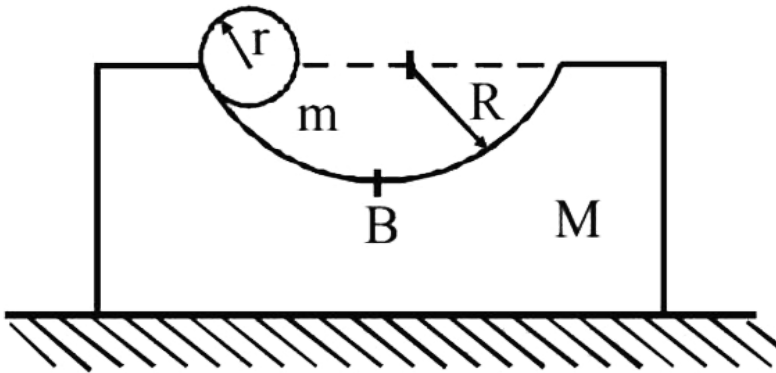

A. $M \sqrt{\frac{2g(R - r)}{M(M + m)}}$

B. $m \sqrt{\frac{2g(R - r)}{m(M + m)}}$

$$C. m \sqrt{\frac{2g(R - r)}{M(M + m)}}$$

$$D. M \sqrt{\frac{2g(R + r)}{M(M + m)}}$$

Answer:



Watch Video Solution

49. A skater of mass m standing on ice throws a stone of mass M with a velocity of v in a horizontal direction. The distance over which the skater will move back (the coefficient of friction between the skater and the ice is μ)

$$A. \frac{M^2 V^2}{2m\mu g}$$

$$B. \frac{MV^2}{2m^2\mu g}$$

$$C. \frac{M^2 V^2}{2m^2\mu g}$$

$$D. \frac{M^2 V^2}{2m^2\mu^2 g}$$

Answer:

 [Watch Video Solution](#)

50. A small ball on a frictionless horizontal surface moves towards right with velocity v . It collides with the wall and returns back and continues to and fro motion. If the average speed for first to and fro motion of the ball is $\left(\frac{2}{3}\right)v$, then the coefficient of restitution of impact is

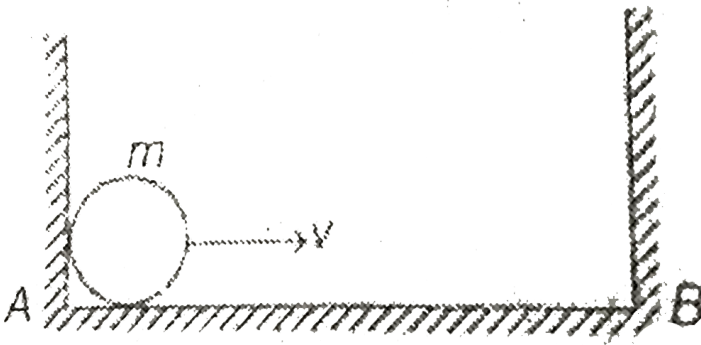

A. 0.5

B. 0.8

C. 0.25

D. 0.75

Answer:



Watch Video Solution

51. A body of mass m is dropped from a height of h . Simultaneously another body of mass $2m$ is thrown up vertically with such a velocity v that they collide at height $\frac{h}{2}$. If the collision is perfectly inelastic, the velocity of combined mass at the time of collision with the ground will be

A. $\sqrt{\frac{5gh}{4}}$

B. \sqrt{gh}

C. $\sqrt{\frac{gh}{4}}$

D. $\sqrt{\frac{13gh}{9}}$

Answer:



Watch Video Solution

52. Choose the correct option:

Two bars of masses m_1 and m_2 connected by a weightless spring of stiffness k , rest on a smooth horizontal plane. Bar 2 is shifted by a small distance x_0 to the left and released. The velocity of the centre of mass of the system when bar 1 breaks

off the wall is

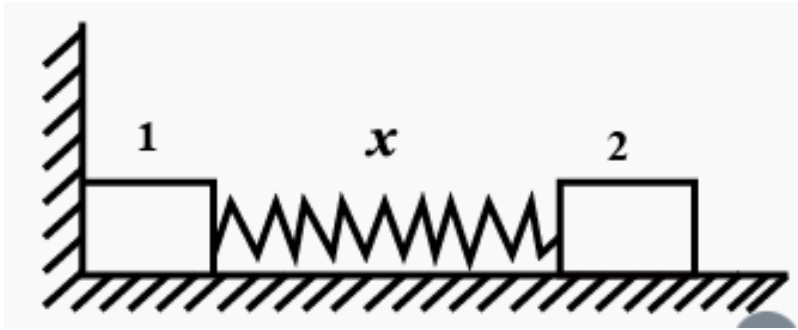

A. (a) $\frac{x\sqrt{m_2k}}{m_1 + m_2}$

B. (b) $x\sqrt{\frac{K}{m_1 + m_2}}$

C. (c) $\frac{x\sqrt{m_1k}}{m_1 + m_2}$

D. (d) $\frac{\sqrt{m_1k}}{m_1 + m_2}$

Answer:



Watch Video Solution

53. A rocket is projected vertically upwards. It explodes at the topmost point of its trajectory into three identical fragments. One of the fragments comes straight down in time t_1 while the other two land at a time t_2 after explosion. Find the height at which the explosion occurred in terms of t_1 and t_2 ?

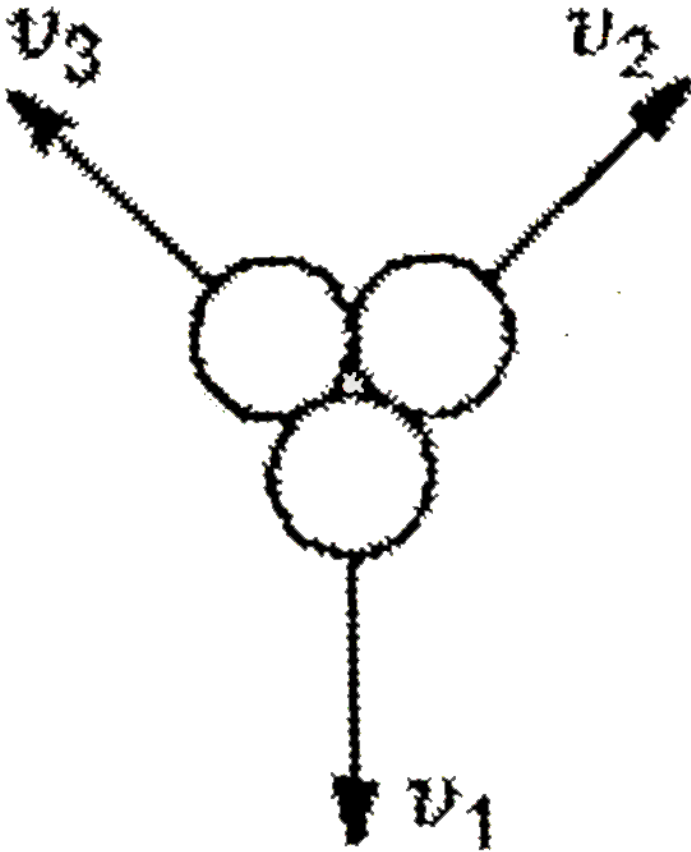

A. $\frac{gt_1t_2(t_2 + 3t_1)}{2(t_1 + t_2)}$

B. $\frac{gt_1t_2^2}{2t_3}$

C. $\frac{gt_1t_2(t_1 + 2t_2)}{2(2t_1 + t_2)}$

D. $\frac{gt_1t_2(2t_1 + t_2)}{4(t_1 + 2t_2)}$

Answer:



Watch Video Solution

54. A raindrop as it falls through fog or mist collects mass at a uniform rate. The drop starts from rest with zero radius and remains spherical at all times. The acceleration with which it falls

A. is constant and equal to $g/2$

B. is constant and equal to $g/3$

C. increases with me

D. decreases with time

Answer:

 [Watch Video Solution](#)

55. Choose the correct option:

A small block of mass 'm' is placed on bigger block of mass M_1 which is placed on a frictionless horizontal surface. The two blocks are given equal speed u_1 but opposite directions, as shown in the figure. After sometime, it is observed that both blocks are moving in the direction of motion of the lower block, with a speed greater than $\frac{u}{2}$. It can be concluded that -

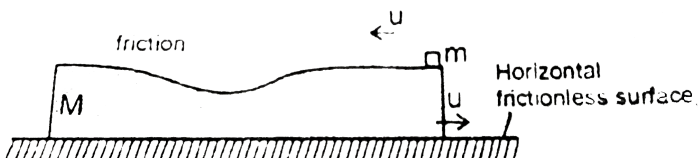

A. (a) $M > 3m$

B. (b) $3M < m$

C. (c) $m > 2M$

D. (d) M and m can have any value such that $M > m$

Answer:



[Watch Video Solution](#)

56. Choose the correct option:

A trolley is moving horizontally with a constant velocity of vm/s w.r.t. earth. A man starts running from one end of the trolley with velocity $1.5vm/s$ w.r.t. to trolley. After reaching the opposite end, the man return back and continues running with a velocity of $1.5vm/s$ w.r.t. the trolley in the backward direction. If the length of the trolley is L then the displacement

of the man with respect to earth during the process will be :-

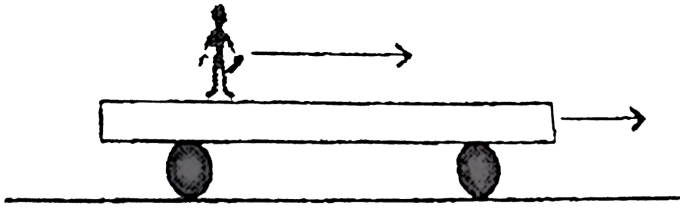

A. (a) $\frac{4}{3}L$

B. (b) $\frac{2}{3}L$

C. (c) $\frac{5L}{3}$

D. (d) $1.5L$

Answer:



Watch Video Solution

57. Choose the correct option:

A bullet of mass m penetrates a thickness h of a fixed plate of

mass M . If the plate was free to move, then the thickness penetrated will be

A. (a) $\frac{hM}{m}$

B. (b) $\frac{hm}{M + m}$

C. (c) $\frac{hM}{M + m}$

D. (d) $\frac{hM}{M}$

Answer:



Watch Video Solution

58. A small particle is placed at the top point A of a fixed smooth hemisphere of radius R . Particle is given small displacement towards right and it starts slipping. Calculate velocity of the particle after hitting horizontal perfectly

inelastic

surface.

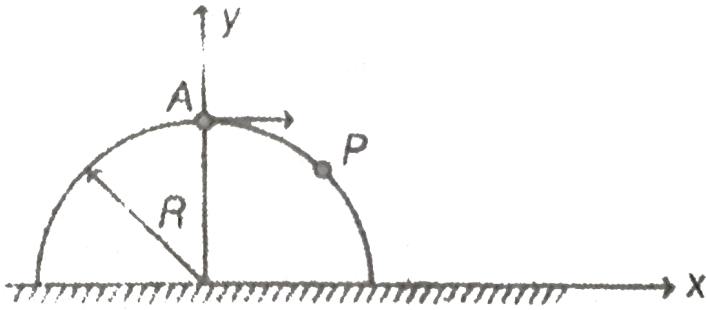

A. \sqrt{gR}

B. $\sqrt{\frac{2}{3}gR}$

C. $\frac{2}{3}\sqrt{\frac{2}{3}gR}$

D. $\sqrt{\frac{gR}{3}}$

Answer:



Watch Video Solution

59. Three masses A, B and C are kept on a smooth horizontal surface as shown in the figure. A sharp impulse is given to the mass A, so that it starts moving towards B with speed v_0 . What is the minimum value of m so that there is only one collision between masses A and B (all collisions are elastic)

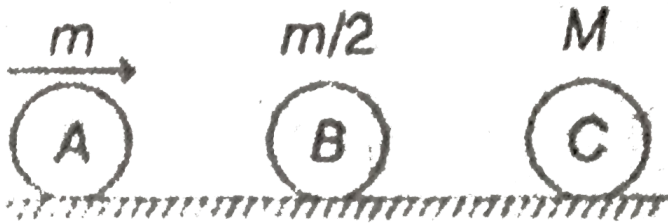

A. M

B. $\frac{10M}{3}$

C. $\frac{8M}{3}$

D. $(2M)$

Answer:



Watch Video Solution

60. A block of mass m is attached with a spring of force constant k . The block is kept on a frictionless plank. Mass of the plank is M and it is also kept on a horizontal frictionless surface. Initially the system is stationary. An impulse p is applied on the block as shown. The maximum compression in the spring will be

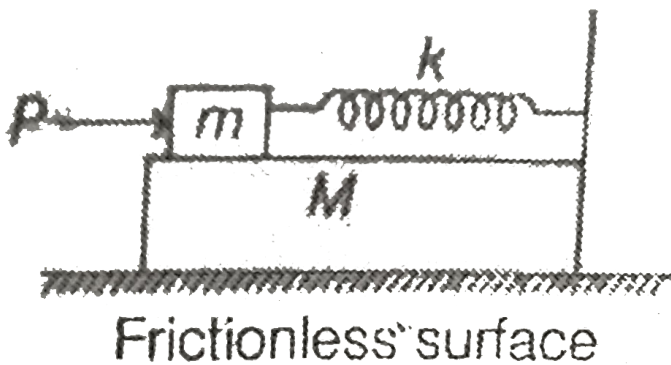

- A. $\sqrt{\frac{MP^2}{m(M+m)k}}$
- B. $\sqrt{\frac{mP^2}{M(M+m)k}}$

C. $\sqrt{\frac{MP^2}{m^2k}}$

D. $\sqrt{\frac{MP^2}{M^2k}}$

Answer:



Watch Video Solution

More A Than One Option Is Correct

1. A ball mass 2 kg moving horizontally with velocity 10 m/s hits a wedge of mass 5 kg placed on a horizontal surface as shown in the figure. Just after collision the velocity of wedge is 3.2 m/s.

There is no friction at any contact surface. Then (take \sin

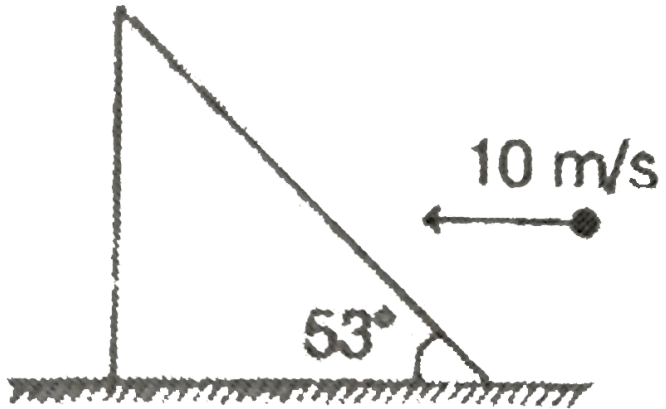

$30^\circ = 3/5$)

- A. Speed of ball just collision is $2\sqrt{10} \text{ m/s}$
- B. Impulse applied by ball on the wedge during collision is 20 N-s
- C. Both are correct
- D. Both are wrong

Answer:

 [Watch Video Solution](#)

Comprehension Type Questions

1. Comprehension # 1

If net force on a system in a particular direction is zero (say in horizontal direction), we can apply: $\Sigma m_R x_R = \Sigma m_L x_L$,

$$\Sigma m_R v_R = \Sigma m_L v_L \text{ and } \Sigma m_R a_R = \Sigma m_L a_L$$

Here R stands for the masses which are moving towards right and L for the masses towards left, x is displacement, v is velocity and a the acceleration (all with respect to ground).

A small block of mass $m = 1\text{kg}$ is placed over a wedge of mass $M = 4\text{kg}$ as shown in figure. Mass m is released from rest. All surface are smooth. Origin O is as shown.

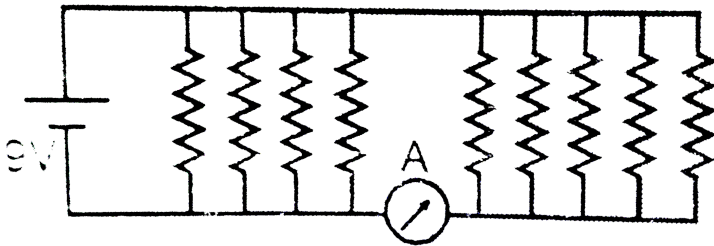

Final velocity of the wedge is m/s :-

A. $\sqrt{3}$

B. $\sqrt{2}$

C. $\frac{1}{\sqrt{2}}$

D. $\frac{1}{\sqrt{3}}$

Answer:



Watch Video Solution

2. Comprehension # 1

If net force on a system in a particular direction is zero (say in horizontal direction), we can apply: $\Sigma m_R x_R = \Sigma m_L x_L$,

$$\Sigma m_R v_R = \Sigma m_L v_L \text{ and } \Sigma m_R a_R = \Sigma m_L a_L$$

Here R stands for the masses which are moving towards right and L for the masses towards left, x is displacement, v is velocity and a the acceleration (all with respect to ground).

A small block of mass $m = 1\text{kg}$ is placed over a wedge of mass $M = 4\text{kg}$ as shown in figure. Mass m is released from rest. All surface are smooth. Origin O is as shown.

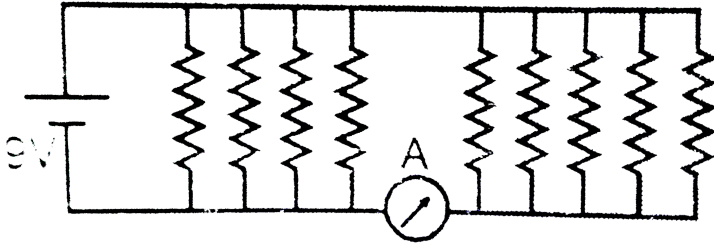

The block will strike the x-axis at $x = \dots\dots\dots m :-$

- A. 4.2
- B. 7.6
- C. 5.6
- D. 6.8

Answer:

 [Watch Video Solution](#)

3. Comprehension # 1

If net force on a system in a particular direction is zero (say in horizontal direction), we can apply: $\Sigma m_R x_R = \Sigma m_L x_L$,
 $\Sigma m_R v_R = \Sigma m_L v_L$ and $\Sigma m_R a_R = \Sigma m_L a_L$

Here R stands for the masses which are moving towards right and L for the masses towards left, x is displacement, v is velocity and a the acceleration (all with respect to ground).

A small block of mass $m = 1\text{kg}$ is placed over a wedge of mass $M = 4\text{kg}$ as shown in figure. Mass m is released from rest. All surface are smooth. Origin O is as shown.

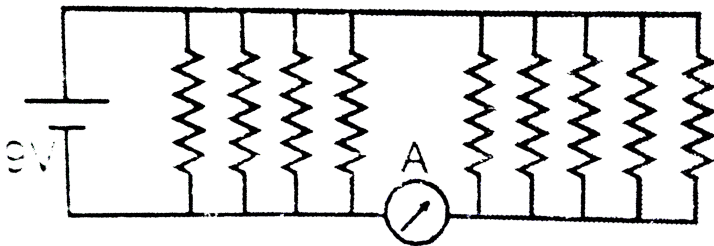

Normal reaction between the two blocks at an instant when absolute acceleration of m is $5\sqrt{3}m/s^2$ at 60° with horizontal

is N. Normal reaction at this instant is making 30° with horizontal.

A. 6

B. 10

C. 4

D. 5

Answer:



[Watch Video Solution](#)

4. Comprehension # 1

If net force on a system in a particular direction is zero (say in horizontal direction) we can apply:

$$\Sigma m_R x_R = \Sigma m_L x_L, \Sigma m_R v_R = \Sigma m_L v_L$$

and

$$\Sigma m_R a_R = \Sigma m_L a_L$$

Here R stands for the masses which are moving towards right and L for the masses towards left, x is displacement, v is velocity and a the acceleration (all with respect to ground). A small block of mass $m = 1\text{kg}$ is placed over a wedge of mass $M = 4\text{kg}$ as shown in figure. Mass m is released from rest. All surface are smooth. Origin O is as shown.

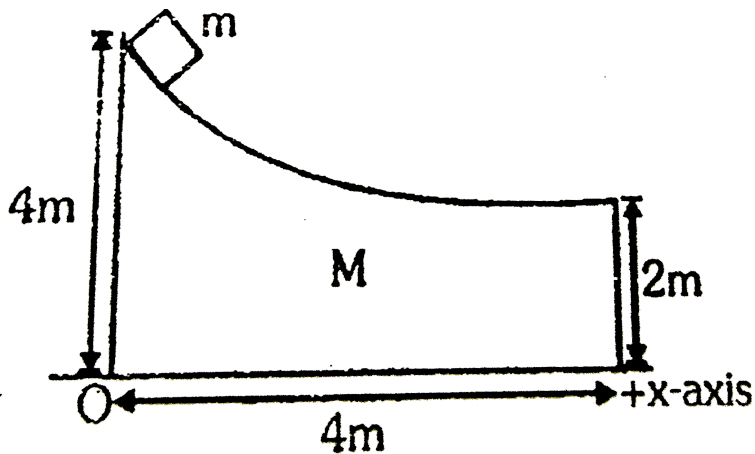

At the same instant reaction on the wedge from the ground isN.

A. 42.5

B. 40

C. 43.46

D. None of the above

Answer:

 [Watch Video Solution](#)

5. Comprehension # 2

When two bodies collide normally they exert equal and opposite impulses on each other. Impulse = change in linear momentum. Coefficient of restitution between two bodies is given by :- $e = \frac{|\text{Relative velocity of separation}|}{|\text{Relative velocity of approach}|} = 1$, for elastic collision.

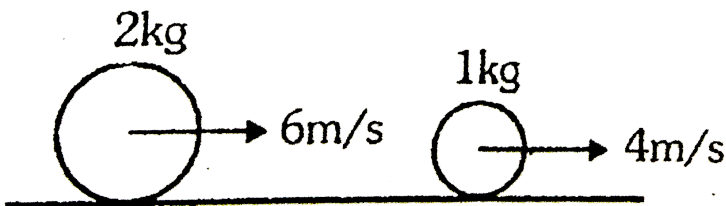

Two bodies collide as shown in figure. During collision they exert impulse of magnitude J on each other.

If the collision is elastic, the value of J is Ns .

A. $10/3$

B. $5/4$

C. $8/3$

D. $3/2$

Answer:



[Watch Video Solution](#)

6. Comprehension # 2

When two bodies collide normally they exert equal and opposite impulses on each other. Impulse = change in linear

momentum. Coefficient of restitution between two bodies is given by :-

$$e = \frac{|\text{Relative velocity of separation}|}{|\text{Relative velocity of approach}|} = 1, \text{ for elastic collision}$$



Two bodies collide as shown in figure. During collision they exert impulse of magnitude J on each other.

For what value of J (in Ns) the $2kg$ block will change its direction of velocity?

- A. $J < 12$
- B. $J > 12$
- C. $J < 10$
- D. $J > 10$

Answer:



Watch Video Solution

7. Two identical masses are as shown in figure. One is thrown upwards with velocity 20 m/s and another is just dropped simultaneously.

The masses collide in air and stick together. After how much time the combined mass will fall to the ground (calculate the time from the starting when the motion was started)

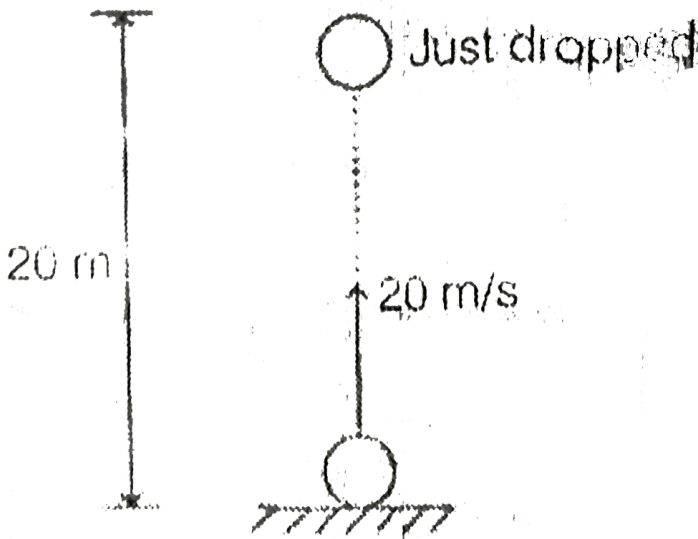

A. $(1 + \sqrt{2})s$

B. $2\sqrt{2}s$

C. $(2 + \sqrt{2})s$

D. None of the above

Answer:



[Watch Video Solution](#)

8. Two identical masses are as shown in figure. One is thrown upwards with velocity 20 m/s and another is just dropped simultaneously.

In the above problem, to what maximum height (from ground) with the combined mass rise ?

A. 25 m

B. 18 m

C. 15 m

D. 20 m

Answer:



[Watch Video Solution](#)

9. Two identical masses are as shown in figure. One is thrown upwards with velocity 20 m/s and another is just dropped simultaneously.

If the collision between them is elastic, find the time interval between their striking with ground 

A. Zero

B. 2 s

C. 1 s

D. 3 s

Answer:



Watch Video Solution

10. Comprehension # 4

When the mass of a system is variable, a thrust force has to be applied on it in addition to all other forces acting on it. This thrust force is given by : $\vec{F} = \vec{v}_r \left(\pm \frac{dm}{dt} \right)$. Here \vec{v}_r is the relative velocity with which the mass dm either enters or leaves the system.

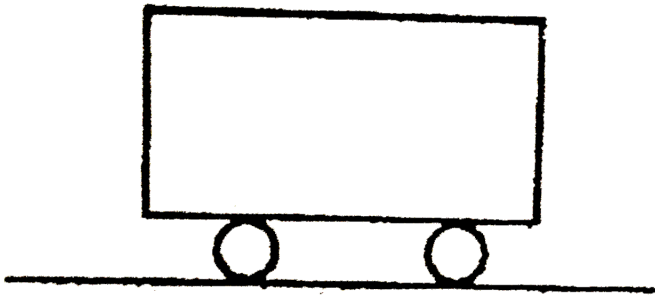

A car has total mass 50kg . Gases are ejected from its backwards with relative velocity 20m/s . The rate of ejection of gas is 2kg/s . Total mass of gas is 20kg . Coefficient of friction between the car and road is $\mu = 0.1$.

Car will start moving after time $t = \dots\dots\dots\text{s}$.

A. 4

B. 10

C. 5

D. 8

Answer:



11. Comprehension # 4

When the mass of a system is variable, a thrust force has to be applied on it in addition to all other forces acting on it. This thrust force is given by : $\vec{F} = \vec{v}_r \left(\pm \frac{dm}{dt} \right)$. Here \vec{v}_r is the relative velocity with which the mass dm either enters or leaves the system.

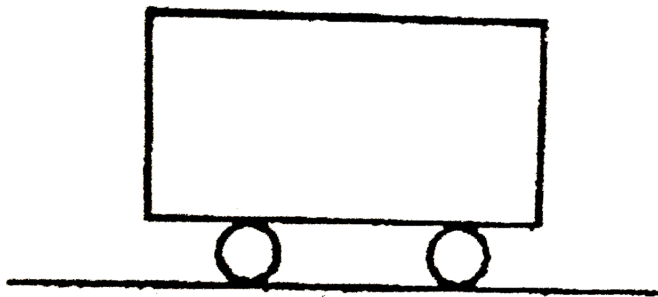

A car has total mass $50kg$. Gases are ejected from its backwards with relative velocity $20m/s$. The rate of ejection of gas is $2kg/s$. Total mass of gas is $20kg$. Coefficient of friction between

the car and road is $\mu = 0.1$.

Maximum speed of car will be $v = \dots\dots m/s$:- (Take

$$\ln\left(\frac{4}{3}\right) = 0.28)$$

A. 0.6

B. 0.8

C. 1.0

D. 1.2

Answer:



Watch Video Solution

12. A car has total mass 50 kg. Gases are ejected from this car backwards with relative velocity 20 m/s. The rate of ejection of gases is 2 kg/s. Total mass of gas is 20 kg. Coefficient of friction

between the car and road is $\mu = 0.1$

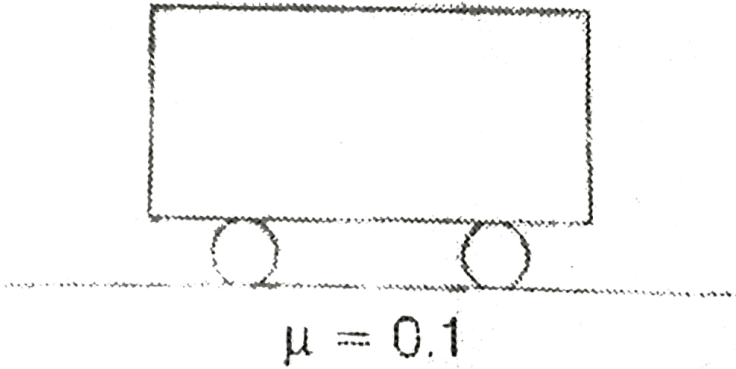

Car will start moving after time $t = \dots\dots\dots$ second.

A. 12.2

B. 6.4

C. 10.6

D. 5.8

Answer:

 [Watch Video Solution](#)

13. Acceleration of two identical particles moving in a straight line are as shown in figure.

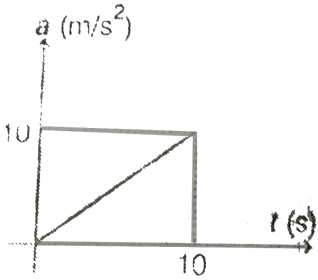

(i)

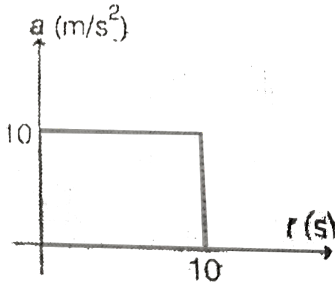

(ii)

The corresponding a - t graph of their centre of mass will be

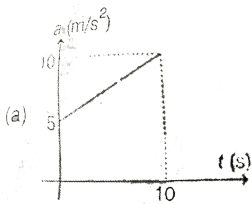

A.

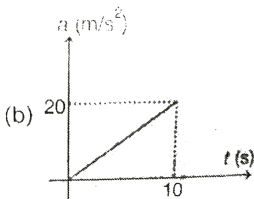

B.

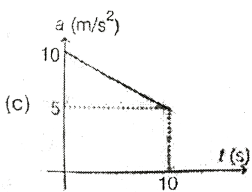

C.

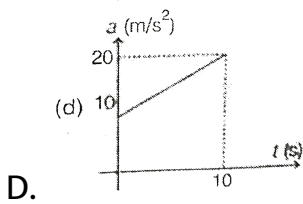

Answer:

 [Watch Video Solution](#)

14. Acceleration of two identical particles moving in a straight line are as shown in figure.

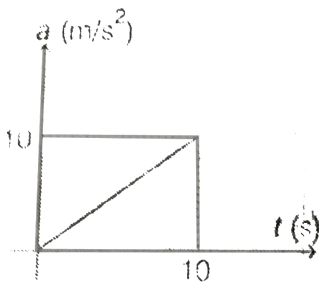

(i)

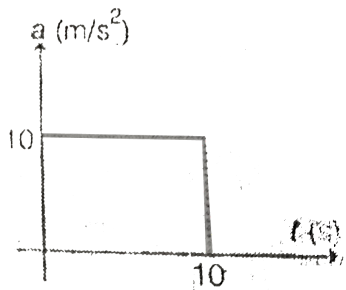

(ii)

If initial velocity of both the particles was zero. Then velocity of their centre of mass after 10 s will be

A. 40 m/s

B. 60 m/s

C. 75 m/s

D. 120 m/s

Answer:



Watch Video Solution

15. Comprehension # 5

One particle of mass 1kg is moving along positive x -axis with velocity 3m/s . Another particle of mass 2kg is moving along y -axis with 6m/s . At time $t = 0$, 1kg mass is at $(3\text{m}, 0)$ and 2kg at $(0, 9\text{m})$, $x - y$ plane is the horizontal plane. (Surface is smooth for question 1 and rough for question 2 and 3)

The centre of mass of the two particles is moving in a straight line for which equation is :

A. $y=x+2$

B. $y=4x+2$

C. $y=2x-4$

D. $y=2x+4$

Answer:



[Watch Video Solution](#)

Others

1. A long block A is at rest on a smooth horizontal surface. A small block B, whose mass is half of A, is placed on A at one end

and projected along A with some velocity u . The coefficient of friction between the blocks is μ :

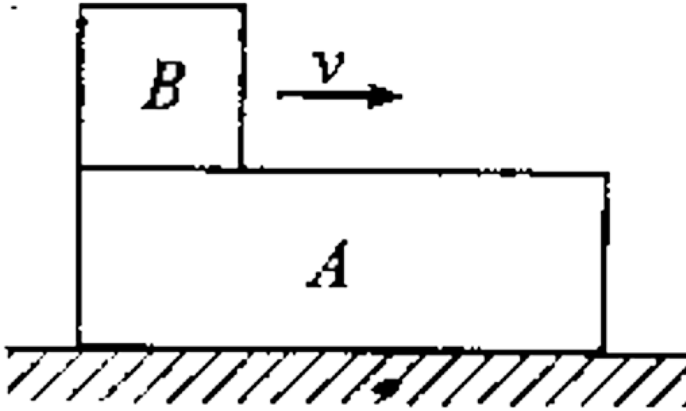

- A. the blocks will reach a final common velocity $u/3$
- B. the work done against friction is two-third of the initial kinetic energy of B
- C. before the block reach a common velocity the acceleration of A relative to B is $(2/3) \mu g$
- D. before the blocks reach a common velocity, the acceleration of A relative to B is $(3/2) \mu g$

Answer:



[Watch Video Solution](#)

2. In a one dimensional collision between two identical particles A and B, B is stationary and A has momentum p before impact. During impact, B gives impulse J to A.

- A. the total momentum of A plus B system is p before and after the impact and $(p - J)$ during the impact
- B. during the impact B gives impulse J to A
- C. the coefficient of restitution is $(2J/p) - 1$
- D. the coefficient of restitution is $(2J/p) + 1$

Answer:



[Watch Video Solution](#)

3. Ball A of mass m strikes a stationary ball B of mass M and undergoes an elastic collision. After collision ball A has a speed one third of its initial speed. The ratio of M/m is

A. $\frac{1}{4}$

B. $\frac{1}{2}$

C. 2

D. 4

Answer:



Watch Video Solution

4. Two small balls A and B of mass M and $3M$ hang from the ceiling by strings of equal length. The ball A is drawn aside, so that it is raised to a height H . It is then released and collides with ball B. Select the correct answer (s)

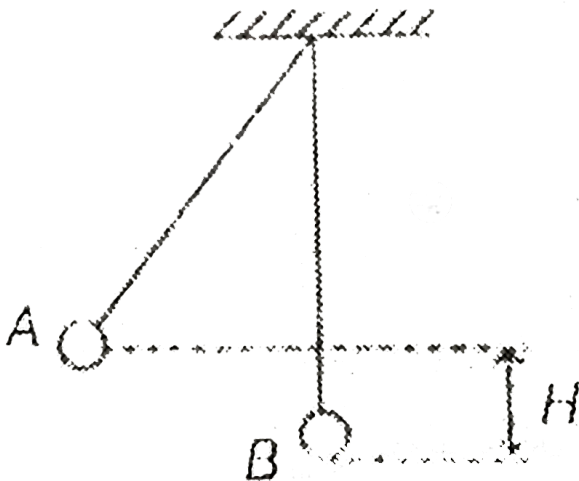

- A. If collision is elastic, ball B will rise to a height $H/4$
- B. If the collision is elastic ball A will rise up to a height $H/4$
- C. If the collision is perfectly inelastic, the combined mass will rise to a height $H/16$

D. If the collision is perfectly inelastic, the combined mass will rise to a height $H/4$

Answer: A,D



Watch Video Solution

5. Two particles of equal mass are projected simultaneously from the roof of a tower of height 20 m with same speed 20 m/s , one horizontally and the other vertically upwards. Choose the correct alternative (s).

- A. The acceleration of center of mass is $g/2$ downwards
- B. The acceleration of centre of mass is g downwards
- C. Maximum height of centre of mass from the ground is 25 m

D. Maximum height of centre of mass from the ground is 40

m

Answer:



[Watch Video Solution](#)

6. Two particles of same mass and charge are thrown in same direction along the horizontal with same velocity v from two different heights h_1 and h_2 ($h_1 < h_2$). Initially they were located in the same vertical line. Select the correct alternative (s).

A. Both the particles always lie on a vertical line

B. Acceleration of the centre of mass of the two particles is g downwards

C. Horizontal displacement on reaching to ground of particle lying at h_1 is less than the value, which would had been in the absence of charges on them

D. Horizontal displacement on reaching to ground of particle lying at h_2 is more than the value, which would had been in the absence of charges on them

Answer:



Watch Video Solution

7. A ball A collides elastically with an another identical ball B with velocity 10 m/s at an angle of 30° from the line joining

their centres C_1 and C_2 . Select the correct alternative (s).

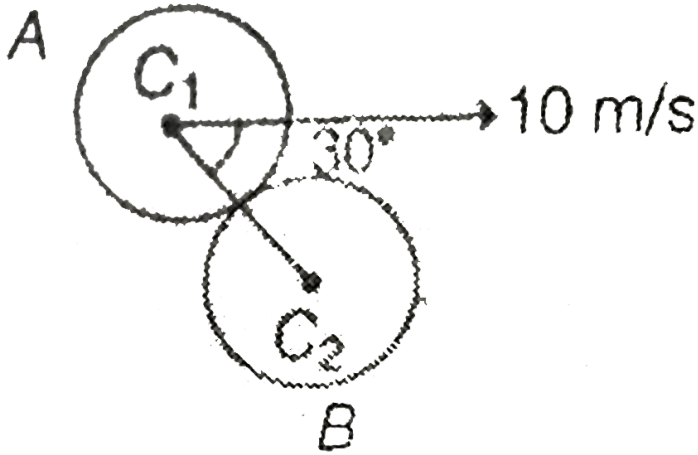

- A. Velocity of ball A after collision is 5 m/s
- B. Velocity of ball B after collision is $5\sqrt{3} \text{ m/s}$
- C. Velocity of ball B after collision is $10\sqrt{3} \text{ m/s}$
- D. Kinetic energy will not be conserved here, because collision is not head on

Answer: B,C,D



Watch Video Solution

8. A projectile is fixed on a horizontal ground. Coefficient of restitution between the projectile and the ground is 'e'. If a , b and c be the ration of time of flight $\left[\frac{T_1}{T_2} \right]$, maximum height $\left[\frac{H_1}{H_2} \right]$ and horizontal range $\left[\frac{R_1}{R_2} \right]$ in first two collisions with the ground, then a , b and c in terms of 'e' will be



[Watch Video Solution](#)

9. A man of mass m is standing on a stationary flat car of mass M . The car can move without friction along horizontal rails. The man starts walking with velocity v relative to the car. Work done by him

A. is less than $\frac{1}{2}mv^2$, if he walks along the rails

B. is equal to $\frac{1}{2}mv^2$, if he walks normal to the rails

C. can never be less than $\frac{1}{2}mv^2$,

D. is greater than $\frac{1}{2}mv^2$, if he walks along the rails

Answer:



[Watch Video Solution](#)

10. A particle moving with kinetic energy E makes a head on elastic collision with an identical particle at rest. During the collision

A. elastic potential energy of the system is always zero

B. maximum elastic potential energy of the system is $E/2$

C. minimum kinetic energy of the system is $E/2$

D. kinetic energy of the system is constant

Answer: B,C

 Watch Video Solution

11. A body is fired from point P and strikes at Q inside a smooth circular wall as shown in the figure. It rebounds to point S (diametrically opposite to P), then

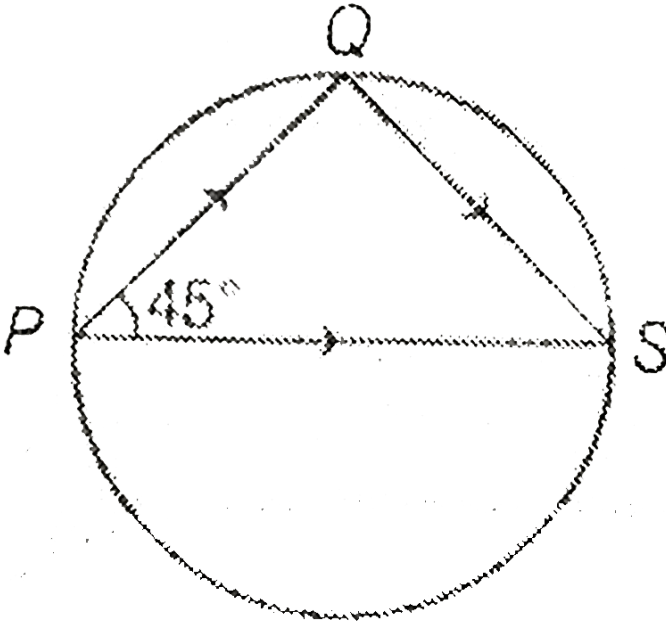

- A. the coefficient of restitution is $\frac{1}{2}$
- B. the coefficient of restitution is 1
- C. kinetic energy is conserved in this collision
- D. kinetic energy is not conserved in this collision

Answer: B,D



Watch Video Solution

12. A ball B of mass m is lying at rest on the top surface of a smooth horizontal table 5 m high. Another moving ball A of same mass makes an elastic collision with B slides off the table and strikes the floor at a horizontal distance of 10 m from the table. Then select the correct alternatives (s). $[g = 10 \text{ m/s}^2]$

- A. The velocity of the ball A before collision is 5 m/s

- B. The kinetic energy of the ball B at the time when it strikes the ground is $(mx100)$ J
- C. the velocity of the ball A before collision is 10 m/s
- D. The kinetic energy of the ball B at the time when it strikes the ground is $(50xm)$ J

Answer: C,D



Watch Video Solution

13. A ball strikes the ground at an angle α . and rebound at an angle β . with the vertical as shown in the figure .Then ,

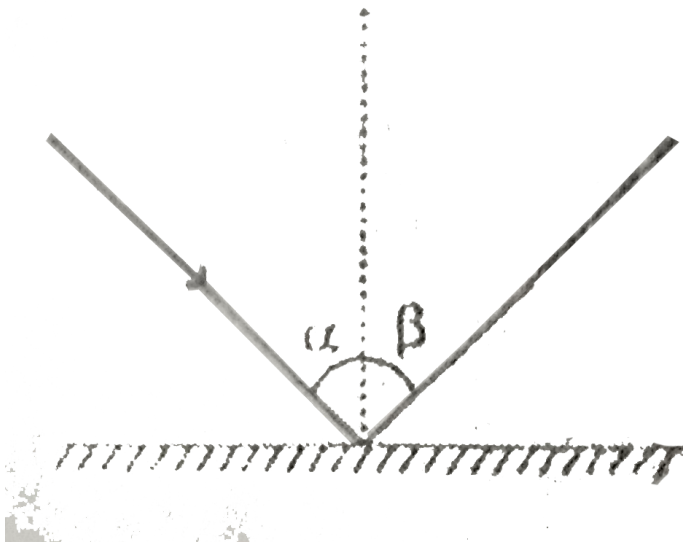

A. coefficient of restitution is $\frac{\tan \alpha}{\tan \beta}$

B. $\alpha < \beta$ the collision is inelastic

C. if $\alpha < \beta$ the collision is elastic

D. if $\alpha > \beta$ the collision is inelastic

Answer:



Watch Video Solution

14. A block of mass m moving with a velocity v_0 collides with a stationary block of mass M to which a spring of stiffness k is attached, as shown in Fig. Choose the correct alternative(s)

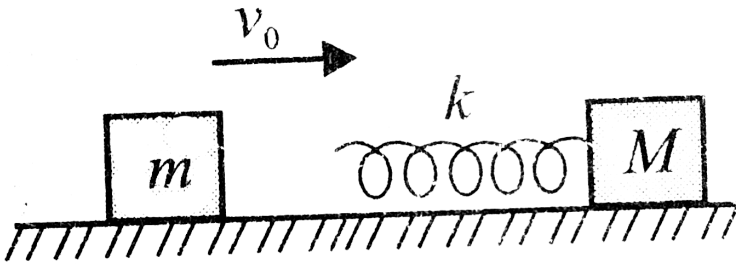

A. The velocity of centre of mass is $\frac{m}{m + M} v_0$

B. The initial kinetic energy of the system in the centre of mass frame is

$$\frac{1}{4} \left(\frac{mM}{M + m} \right) v_0^2$$

C. The maximum compression in the spring is

$$\sqrt{\frac{mM}{(m + M)k}}$$

D. When the spring is in the state of maximum compression

the kinetic energy in the centre of mass frame is zero

Answer:

 [Watch Video Solution](#)

15. A block of mass 1 kg is pushed towards another block of mass 2 kg from 6 m distance as shown in figure. Just after collision velocity of 2 kg block becomes 4 m/s

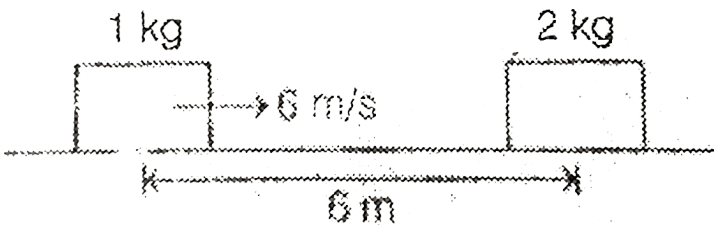

- A. Coefficient of restitution between two blocks is 1
- B. Coefficient of restitution between two blocks is $1/2$
- C. Velocity of centre of mass after 2 s is 2 m/s
- D. Velocity of centre of mass after 2 s is 1 m/s

Answer:

[▶ Watch Video Solution](#)

16. In the system shown in figure block A is not attached with wall. Block B is compressed 1m and then released at time $t = 0$.

Then,

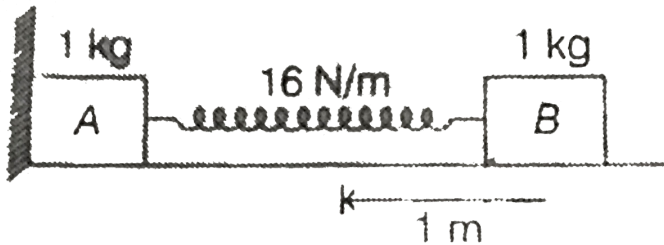

- A. net force of the system is non zero for $< \frac{\pi}{8}$ second
- B. net force on the system is non zero all the time
- C. final velocity of centre of mass is 4 m/s
- D. final velocity of centre of mass is 2 m/s

Answer:



Watch Video Solution

17. In which of the following cases the centre of mass of a rod is certainly not at its centre?

- A. the density continuously increase from left to right
- B. the density continuously decreases from left to right
- C. the density decreases from left to right upto the center and then increases
- D. the density increases from left to right upto the centre and then decreases

Answer:



Watch Video Solution

18. A nonzero external force acts on a system of particles. The velocity and the acceleration of the centre of mass are found to be v_0 and a_0 at an instant t . It is possible that:

A. $v_0 = 0, a_0 = 0$

B. $v_0 = 0, a_0 \neq 0$

C. $v_0 \neq 0, a_0 = 0$

D. $v_0 \neq 0, a_0 \neq 0$

Answer:

19. Two particles A and B of equal size but of masses $m\text{kg}$ and $2m\text{kg}$ are moving directly towards each other with speeds $21m/s$ and $4m/s$ respectively. After collision, A moves with a speed of $1m/s$ in the original direction. Then:

- A. The velocity of B after collision is 6 m/s opposite its direction of motion before collision.
- B. The coefficient of restitution is 0.2
- C. The loss of kinetic energy due to collision is 200 J
- D. The impulse of the force between the two balls is 40 N-s

Answer:



Watch Video Solution

20. Blocks of masses 0.5 kg each, resting on a horizontal frictionless tabletop, are connected with an unstretched spring of length $L = 20 \text{ cm}$, and of spring constant 16 N/m . The mass of the spring is negligible and at a certain moment the blocks are given an initial speed of $v_0 = 0.36 \text{ m/s}$ towards the wall. The block at the right collides with the wall elastically :

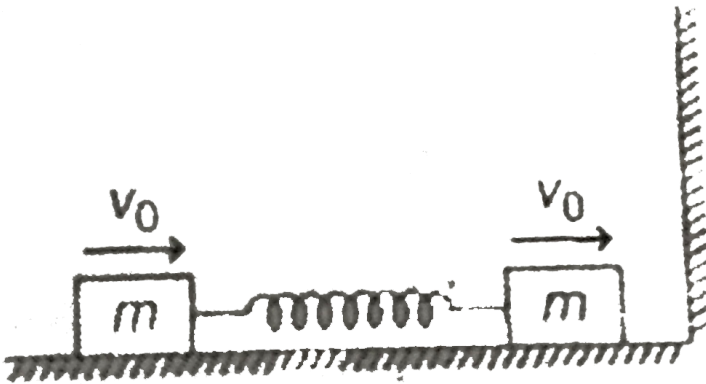

A. There will be 2 collisions with the wall

B. After 1st collision centre of mass comes to rest

C. After 2nd collision centre of mass moves to left with speed v_0

D. After all collisions are over the system oscillates about the centre of mass

Answer:



[Watch Video Solution](#)

21. Two identical particles A and B of mass m each are connected together by a light and inextensible string of length l . The particles are held at rest in air in same horizontal level at a separation l . Both particles are released simultaneously and one of them (say A) is given speed V_0 vertically upward. Choose the correct options (s). Ignore air resistance.

- A. The maximum height attained by the center of mass of the system of A and B is $\frac{v_0^2}{8g}$
- B. The kinetic energy of the system of A and B when the centre of mass is at its highest point is $\frac{mv_0^2}{2}$
- C. The maximum height attained by the centre of mass of the system of A and B is $\frac{v_0^2}{4g}$
- D. The kinetic energy of the system of A and B when the centre of mass is at its highest point is $\frac{mv_0^2}{4}$

Answer:



[Watch Video Solution](#)

22. A smooth sphere A of mass m collides elastically with an identical sphere B at rest. The velocity of A before collision is

8 m/s in a direction making 60° with the line of centres at the

time of impact, Then

- A. The sphere A comes to rest after collision
- B. The sphere B will move with a speed of 8 m/s after collision
- C. The directions of motion of A and B after collision are at right angles
- D. The speed of B after collision is 4 m/s

Answer:



[Watch Video Solution](#)

23. In the figure shown a stationary boy (at a point A) throws a ball towards a fixed wall which is 20 m away from him. The

ball hits the wall elastically and hits the ground at the point B, 20 m behind the boy. The total time elapsed is T_1 . The boy again throws the ball with same speed but at different angle from same point A towards the wall and after collision with the wall ball lands at same point B. But this time elapsed is T_2 . If $(T_2 - T_1) = 1\text{s}$, choose the correct options.

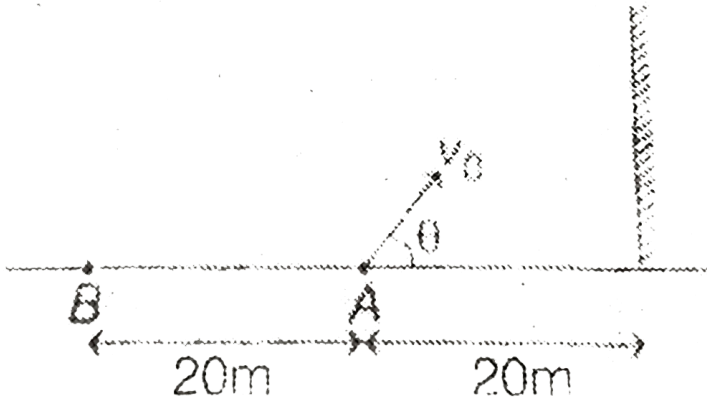

- A. a. Speed of throw of balls is 20 m/s
- B. b. Speed of throw of balls is 25 m/s
- C. c. The difference in their angle of projections is nearly 16°

D. d. The difference in the height of the points where balls hit the wall is nearly 10 m

Answer:

 [Watch Video Solution](#)

24. Comprehension # 5

One particle of mass $1kg$ is moving along positive x -axis with velocity $3m/s$. Another particle of mass $2kg$ is moving along y -axis with $6m/s$. At time $t = 0$, $1kg$ mass is at $(3m, 0)$ and $2kg$ at $(0, 9m)$, $x - y$ plane is the horizontal plane. (Surface is smooth for question 1 and rough for question 2 and 3)

If both the particles have the same value of coefficient of friction $\mu = 0.2$. The centre of mass will stop at time $t = \dots\dots\dots s$

∴

A. 1.5

B. 4.5

C. 3.0

D. 2.0

Answer:



Watch Video Solution

25. Comprehension # 5

One particle of mass 1kg is moving along positive x -axis with velocity 3m/s . Another particle of mass 2kg is moving along y -axis with 6m/s . At time $t = 0$, 1kg mass is at $(3\text{m}, 0)$ and 2kg at $(0, 9\text{m})$, $x - y$ plane is the horizontal plane. (Surface is rough for question, if coefficient of friction is 0.2 in both axis)

Co-ordinates of center of mass where it will stop finally are :-

A. (2.0 m,14.25 m)

B. (2.25 m,10 m)

C. (3.75 m,9 m)

D. (1.75 m,12 m)

Answer:



Watch Video Solution

26. A block of mass 1 kg is moving towards a movable wedge of mass 2 kg as shown in figure. All surfaces are smooth. When the block leaves the wedge from top, its velocity is making an angle $\theta = 30^\circ$ with horizontal.

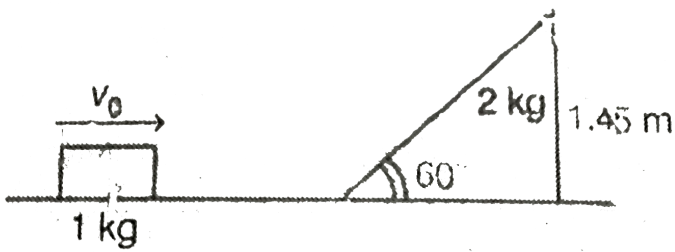

The value of v_0 in m/s is

- A. a. 4
- B. b. 7
- C. c. 10
- D. d. 9

Answer:

[Watch Video Solution](#)

27. A block of mass 1 kg is moving towards a movable wedge of mass 2 kg as shown in figure. All surfaces are smooth. When the

block leaves the wedge from top, its velocity is making an angle

$\theta = 30^\circ$ with horizontal.

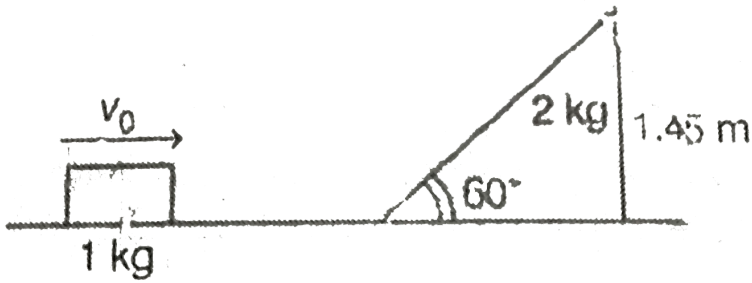

To what maximum height will the block rise

- A. 1.9 m
- B. 2.7 m
- C. 1.6 m
- D. 1.45 m

Answer:

 [Watch Video Solution](#)

28. A block of mass 1 kg is moving towards a movable wedge of mass 2 kg as shown in figure. All surfaces are smooth. When the block leaves the wedge from top, its velocity is making an angle $\theta = 30^\circ$ with horizontal.

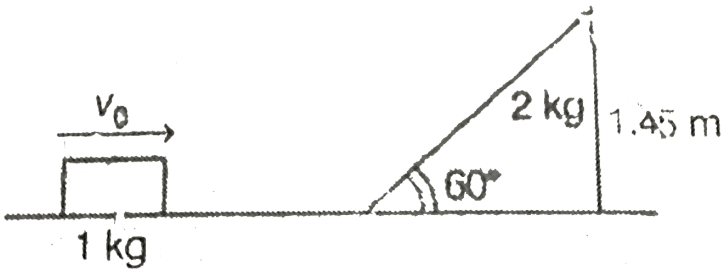

In the whole process let J be the magnitude of net impulse given to the block by the wedge, J_H its horizontal component and J_V its vertical component. Then

A. $J = \frac{8}{\sqrt{3}} \text{ N-s}$

B. $J_H = 4 \text{ N-s}$

C. $J_V = \frac{4}{\sqrt{3}} \text{ N-s}$

D. All of the above

Answer:



Watch Video Solution

29. Two blocks (from very far apart) are approaching towards each other with velocities as shown in figure. The coefficient of friction for the blocks is $\mu = 0.2$.

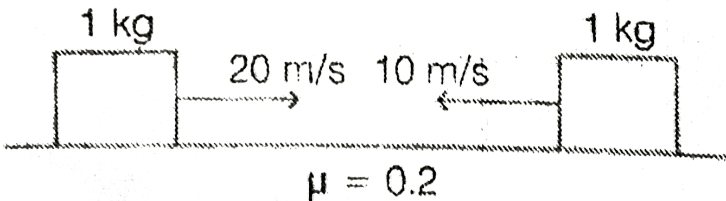

Linear momentum of the system is

- A. conserved all the time
- B. never conserved
- C. is conserved only upto 5 s
- D. None of the above

Answer:

[Watch Video Solution](#)

30. Two blocks (from very far apart) are approaching towards each other with velocities as shown in figure. The coefficient of friction for the blocks is $\mu = 0.2$.

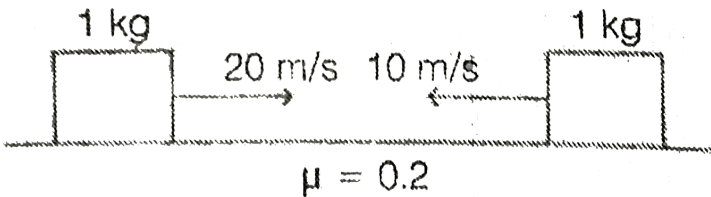

How much distance will centre of mass travel before coming permanently to rest.

- A. 25 m
- B. 37.5 m
- C. 42.5 m

D. 50 m

Answer:

 [Watch Video Solution](#)

31. Comprehension # 6

A 1kg block is given a velocity of 15m/s towards right over a very long rough plank of mass 2kg as shown in figure.

The correct graph showing linear momentum of 1kg (i.e. p_1) and of 2kg (i.e. p_2) versus time is :

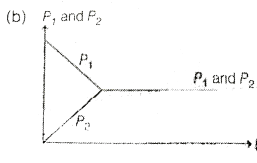
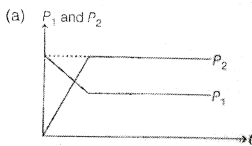

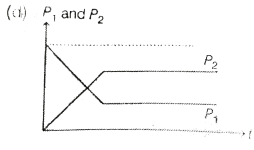
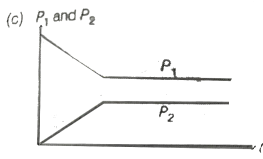

Answer:

 [Watch Video Solution](#)

32. Comprehension # 6

A 1kg block is given a velocity of 15m/s towards right over a very long rough plank of mass 2kg as shown in figure.

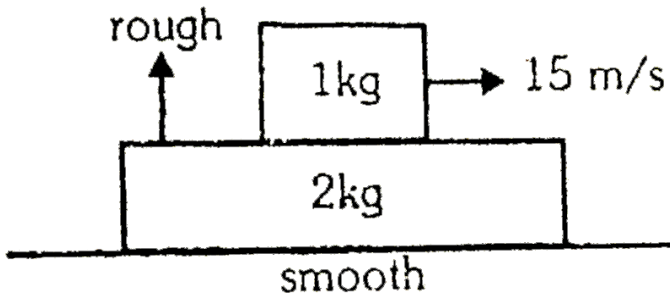

If coefficient of friction between the two blocks is equal to 0.4, then magnitude of initial slope of p_1 versus t and p_2 versus t (in SI unit) will be :-

- A. 4 and 2
- B. 2 and 4
- C. 4 and 4
- D. 2 and 2

Answer:



[Watch Video Solution](#)

33. Comprehension # 6

A 1kg block is given a velocity of 15m/s towards right over a very long rough plank of mass 2kg as shown in figure.

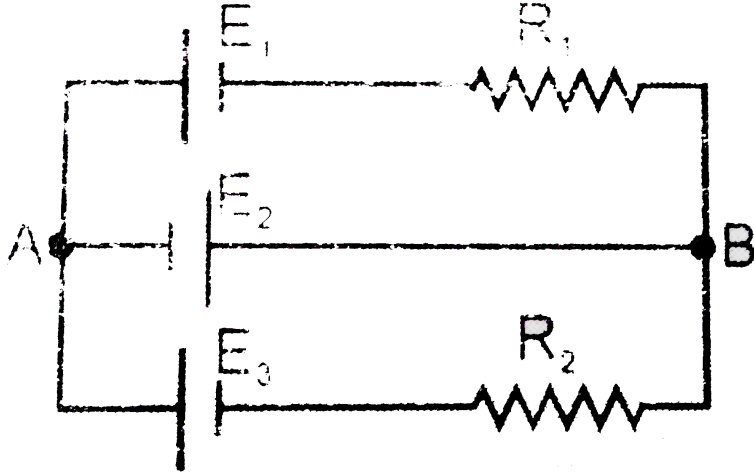

figure. If coefficient of friction between the two blocks is equal to 0.4 Momentum of both the blocks are equal at time $t = \dots\dots\dots s$:

- A. 1.75
- B. 1.875
- C. 2.5
- D. 1.25

Answer:



Watch Video Solution

34. A ball of mass 3 kg is thrown upwards with velocity 20 m/s. After 1 s it explodes in 2 pieces one of mass 1 kg and other of 2 kg. After explosion both the pieces maintain their vertical velocities but on ground they fall 90 m apart.

Speed of both the pieces just after explosion are (both in m/s)

A. $10\sqrt{5}$, $10\sqrt{2}$

B. 30, 20

C. $20\sqrt{3}$, $10\sqrt{3}$

D. $20\sqrt{2}$, 20

Answer:



Watch Video Solution

35. A ball of mass 3 kg is thrown upwards with velocity 20 m/s. After 1 s it explodes in 2 pieces one of mass 1 kg and other of 2 kg. After explosion both the pieces maintain their vertical velocities but on ground they fall 90 m apart. Energy produced (in joule) during explosion is

- A. 150
- B. 200
- C. 300
- D. 450

Answer:



[Watch Video Solution](#)

36. Two blocks of equal mass m are connected by an unstretched spring and the system is kept at rest on a frictionless horizontal surface. A constant force F is applied on the first block pulling away from the other as shown in Fig.

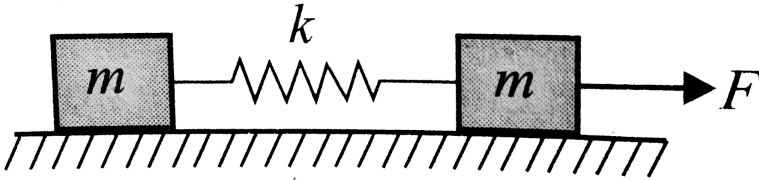

Then the displacement of the centre of mass in at time t is

- A. $\frac{Ft^2}{2m}$
- B. $\frac{Ft^2}{3m}$
- C. $\frac{Ft^2}{4m}$
- D. $\frac{Ft^2}{m}$

Answer:

37. Two blocks of equal mass m are connected by an unstretched spring and the system is kept at rest on a frictionless horizontal surface. A constant force F is applied on the first block pulling away from the other as shown in Fig.

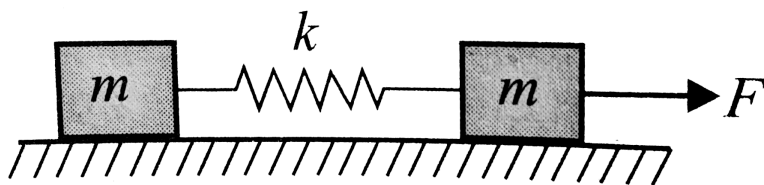

If the extension of the spring is x_0 at time t , then the displacement of the first block at this instant is

A. $\frac{1}{2} \left(\frac{Ft^2}{2m} + x_0 \right)$

B. $\left(\frac{Ft^2}{2m} - x_0 \right)$

C. $\frac{1}{2} \left(\frac{Ft^2}{2m} - x_0 \right)$

D. $\left(\frac{Ft^2}{2m} + x_0 \right)$

Answer:

 **Watch Video Solution**

38. Two blocks of equal mass m are connected by an unstretched spring and the system is kept at rest on a frictionless horizontal surface. A constant force F is applied on the first block pulling away from the other as shown in Fig.

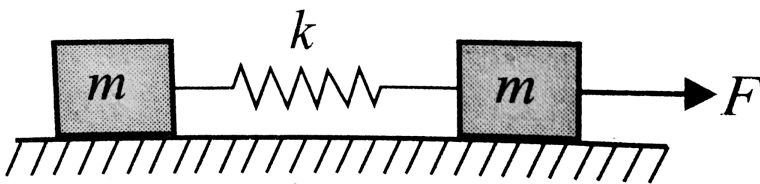

If the extension of the spring is x_0 at time t , then the displacement of the first block at this instant is

A. $\left(\frac{Ft^2}{2m} - \times_0 \right)$

B. $\frac{1}{2} \left(\frac{Ft^2}{2m} + \times_0 \right)$

C. $\frac{1}{2} \left(\frac{2Ft^2}{m} - \times_0 \right)$

D. $\frac{1}{2} \left(\frac{Ft^2}{2m} - \times_0 \right)$

Answer:



Watch Video Solution

39. Two balls marked 1 and 2 of the same mass m and a third ball marked 3 of mass M are arranged over a smooth horizontal surface as shown in the figure. Ball 1 moves with a velocity v_1 towards ball 2. All collisions are assumed to be elastic. If $M < m$, the number of collisions between the balls will be.



- A. one
- B. two
- C. three
- D. four

Answer:

 [Watch Video Solution](#)

40. Two balls marked 1 and 2 of the same mass m and a third ball marked 3 of mass M are arranged over a smooth horizontal surface as shown in the figure. Ball 1 moves with a velocity v_1 towards ball 2. All collisions are assumed to be elastic. If $M < m$, the number of collisions between the balls will be.



A. one

B. two

C. three

D. four

Answer:



Watch Video Solution

41. A system consists of block A and B each of mass m connected by a light spring as shown in the figure with block B in contact with a wall. The block A compresses the spring by $3mg/k$ from natural length of spring and then released from rest. Neglect friction anywhere

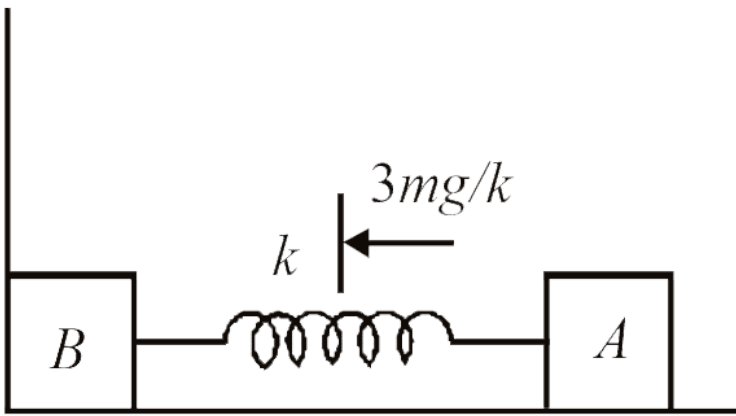

Acceleration of centre of mass of system comprising A and B just after A is released is

- A. 0
- B. $\frac{3g}{2}$
- C. $3g$
- D. $g/2$

Answer:



Watch Video Solution

42. A system consists of block A and B each of mass m connected by a light spring as shown in the figure with block B in contact with a wall. The block A compresses the spring by $3mg/k$ from natural length of spring and then released from rest. Neglect friction anywhere.

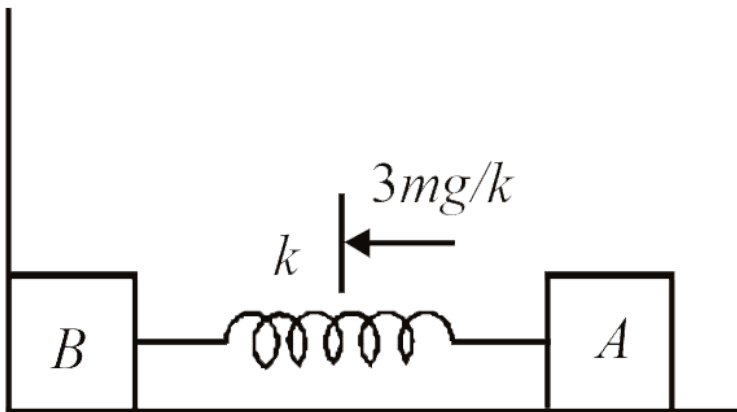

Velocity of centre of mass of system comprising A and B when block B just loses contact with the wall

A. $\sqrt{\frac{m}{K}}$

B. $\frac{3g}{2} \sqrt{\frac{m}{k}}$

C. $2g\sqrt{\frac{m}{k}}$

D. None of these

Answer:

 [Watch Video Solution](#)

43. If net force on a system of particles is zero, then match the following.

Table-1	Table-2
(A) Acceleration of centre of mass	(P) Constant
(B) Momentum of centre of mass	(Q) Zero
(C) Velocity of centre of mass	(R) May be zero
(D) Velocity of an individual particle of the system	(S) May be constant

 [Watch Video Solution](#)

44. In the arrangement shown in figure match the following:

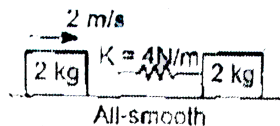

Column-1	Column-2
(A) Velocity of centre of mass	(P) 2 SI unit
(B) Velocity of combined mass when compression in the spring is maximum	(Q) 1 SI unit
(C) Maximum compression in the spring	(R) 4 SI unit
(D) Maximum potential energy stored in the spring	(S) 0.5 SI unit

 [Watch Video Solution](#)

45. A particle of mass m , kinetic energy K and momentum p collides head on elastically with another of mass $2m$ at rest.

Match the following columns after collision.)

column1

column2

A momentum of first particle

P $3/4 p$

B Momentum of second particle

Q $-K/9$

C Kinetic energy of first particle

R $-p/3$

D Kinetic energy of second particle

S $8K/9$



Watch Video Solution

46. Match the following: (P = momentum of particle, K = kinetic energy of particle)

Column-1	Column-2
(A) P is increased by 200%, corresponding change in K	(P) 800%
(B) K is increased by 300%, corresponding change in P	(Q) 200%
(C) P is increased by 1%, corresponding change in K	(R) 0.5%
(D) K is increased by 1%, corresponding change in P	(S) 2%
	(T) None



Watch Video Solution

47. Four points are placed at four corners of a square of side 4 m as shown. Match the following table.

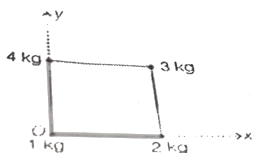

Table-1	Table-2
(A) x -co-ordinate of centre of mass of 4 kg and 2 kg	(P) $(7/2)m$
(B) x -co-ordinate of centre of mass of 4 kg, 2 kg and 3 kg	(Q) $4/3 m$
(C) y -co-ordinate of centre of mass of 1 kg, 4 kg and 3 kg	(R) $3 m$
(D) y -co-ordinate of centre of mass of 1 kg and 3 kg	(S) $(20/9) m$



Watch Video Solution

48. In a two block system shown in figure match the following.

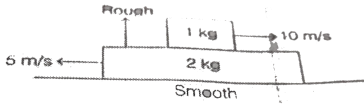

Table-1	Table-2
(A) Velocity of centre of mass	(P) Keep on changing all the time
(B) Momentum of centre of mass	(Q) First decreases then becomes zero
(C) Momentum of 1 kg block	(R) Zero
(D) Kinetic energy of 2 kg block	(S) Constant

[Watch Video Solution](#)

49. Two balls of mass m and $2m$ each have momentum $2p$ and p in the direction shown in figure. During collision they exert an impulse of magnitude p on each other.



Column I	Column II
(A) After collision momentum of m	(p) $2p$
(B) After collision momentum of $2m$	(q) p
(C) Coefficient of restitution between them	(r) 1
	(s) None

 [Watch Video Solution](#)

50. A particle of mass 1 kg is projected upwards with velocity 60 m/s. Another particle of mass 2 kg is just deopper from a certain height. After 2 kg is just of the particles have collided with ground, match the following [Take $g = 10 \text{ m/s}^2$]

 [Watch Video Solution](#)