



## PHYSICS

### BOOKS - DC PANDEY ENGLISH

#### CIRCULAR MOTION

#### Example

1. A particle moves in a circular path of radius  $0.5m$  at a speed that uniformly increases. Find the angular acceleration of particle if its speed changes from  $2.0m/s$  to  $4.0m/s$  in  $4.0s$



[Watch Video Solution](#)

2. The speed of a particle moving in a circle of radius  $r = 2m$  varies with time  $t$  as  $v = t^2$ , where  $t$  is in second and  $v$  in  $m/s$ . Find the radial,

tangential and net acceleration at  $t = 2s$ .

 [Watch Video Solution](#)

3. In circular motion, what are the possible values (zero, positive or negative) of the following:

(a)  $\omega$ .  $v$  (b)  $v$ .  $a$ , (c)  $\omega$ .  $\alpha$

 [Watch Video Solution](#)

4. A small block of mass  $100g$  moves with uniform speed in a horizontal circular groove, with vertical side walls of radius  $25cm$ . If the block takes  $2.0s$  to complete one round, find the constant force by the side wall of the groove.

 [Watch Video Solution](#)



5. A fighter plane is pulling out for a dive at a speed of  $900\text{km/h}$ . Assuming its path to be a vertical circle of radius  $2000\text{m}$  and its mass to be  $16000\text{kg}$ , find the force exerted by the air on it at the lowest point.

Take  $g = 9.8\text{m/s}^2$

 [Watch Video Solution](#)

6. Three particles, each of the mass  $m$  are situated at the vertices of an equilateral triangle of side  $a$ . The only forces acting on the particles are their mutual gravitational forces. It is desired that each particle moves in a circle while maintaining the original mutual separation  $a$ . Find the initial velocity that should be given to each particle and also the time period of the circular motion.  $\left( F = \frac{Gm_1m_2}{r^2} \right)$

 [Watch Video Solution](#)

7. (a) How many revolutions per minute must the apparatus shown in figure make about a vertical axis so that the cord makes an angle of  $45^\circ$

with the vertical ?

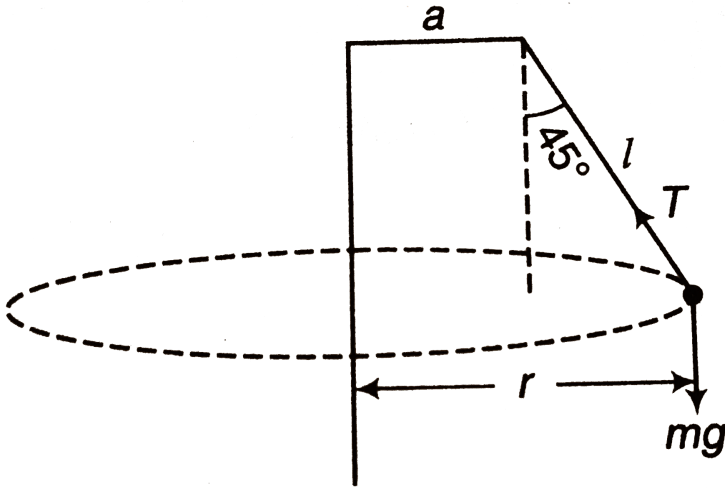

(b) What is the tension in the cord then? Given,  $l = \sqrt{2}m$ ,  $a = 20\text{cm}$  and  $m = 5.0\text{kg}$ ?

[▶ Watch Video Solution](#)

8. A turn of radius  $20\text{m}$  is banked for the vehicle of mass  $200\text{kg}$  going at a speed of  $10\text{m/s}$ . Find the direction and magnitude of frictional force (a)

$5\text{m/s}$

(b)  $15\text{m/s}$

Assume that friction is sufficient to prevent slipping. ( $g = 10\text{m/s}^2$ )



[Watch Video Solution](#)

9. A particle of mass  $m$  is placed over a horizontal circular table rotating with an angular velocity  $\omega$  about a vertical axis passing through its centre. The distance of the object from the axis is  $r$ . Find the force of friction  $f$  between the particle and the table.



[Watch Video Solution](#)

10. Two blocks  $A$  and  $B$  of masses  $1kg$  and  $3kg$  are attached with two massless strings as shown in figure. The system is kept over a smooth table and it rotates about the axis shown in figure with constant angular speed  $\omega = 2rad/s$ . Find direction and magnitude of centrifugal force on

(a)  $A$  as observed by  $B$

(b)  $B$  as observed by  $A$



[Watch Video Solution](#)

11. A stone tied to a string of length  $L$  is whirled in a vertical circle with the other end of the string at the centre. At a certain instant of time the stone is at lowest position and has a speed  $u$ . Find the magnitude of the change in its velocity as it reaches a position, where the string is horizontal.



[Watch Video Solution](#)

12. With what minimum speed  $v$  must a small ball should be pushed inside a smooth vertical tube from a height  $h$  so that it may reach the

top of the tube? Radius of the tube is  $R$  .

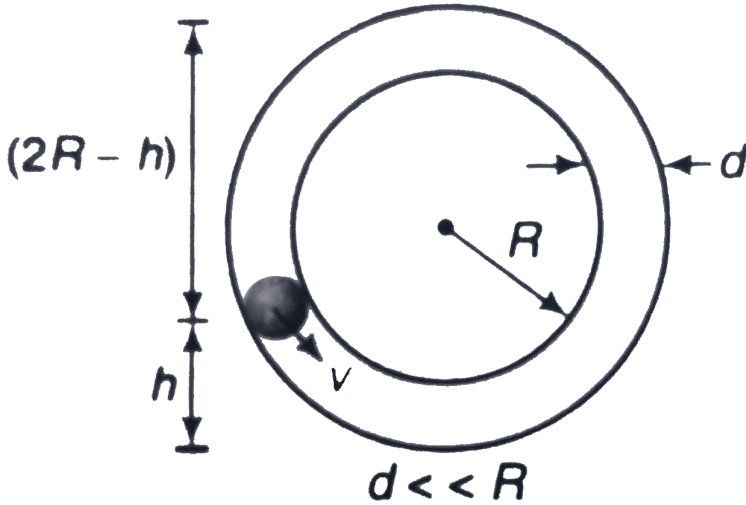

[▶ Watch Video Solution](#)

13. A particle is suspended from a fixed point by a string of length  $5m$ . It is projected from the equilibrium position with such a velocity that the string slackens after the particle has reached a height  $8m$  above lowest point. Find the velocity of the particle, just before the string slackens.

Find also, to what to what height the particle can rise further?

[▶ Watch Video Solution](#)

14. A heavy particle hanging from a fixed point by a light inextensible string of length  $l$  is projected horizontally with speed  $\sqrt{gl}$ . Find the speed of the particle and the inclination of the string to the vertical at the instant of the motion when the tension in the string is equal to the weight of the particle.

 [Watch Video Solution](#)

15. Calculate the average angular velocity of the hour hand of the of a clock.

 [Watch Video Solution](#)

16. An object revolves uniformly in a circle of diameter 0.80 m and completes  $100 \text{ rev min}^{-1}$ . Find its time period and angular velocity.

 [Watch Video Solution](#)

17. One end of a cylindrical glass rod ( $\mu = 1.5$ ) of radius 1.0 cm is rounded in the shape of a hemisphere. The rod is immersed in water ( $\mu = 4/3$ ) and an object is placed in the water along the axis of the rod at a distance of 8.0 cm from the rounded edge. Locate the image of the object.

 [Watch Video Solution](#)

18. A particle moves in a circle of radius 4 m with a linear velocity of  $20\text{ms}^{-1}$ . Find the angular velocity.

 [Watch Video Solution](#)

19. If the length of the second's hand in a stop clock is 3 cm the angular velocity and linear velocity of the tip is

 [Watch Video Solution](#)

20. A point on the rim of a disc starts circular motion from rest and after time  $t$ , it gains an angular acceleration given by  $\alpha = 3t - t^2$ . Calculate the angular velocity after 2 s.



[Watch Video Solution](#)

21. The wheel of a motor rotates with a constant acceleration of  $4 \text{ rad s}^{-1}$ . If the wheel starts from rest, how many revolutions will it make in the first 20 second?



[Watch Video Solution](#)

22. The wheel of a car, accelerated uniformly from rest, rotates through 1.5 rad during the first second. Find the angle rotated during the next second.



[Watch Video Solution](#)



23. Find the magnitude of the centripetal acceleration of a particle on the tip of a blade, 0.30 metre in diameter, rotating at 1200 revolution per minute.

 [Watch Video Solution](#)

24. Find the acceleration of a particle placed on the surface of the earth at the equator, due to the earth rotation. The radius of earth is 6400 km and time period of revolution of the earth about its axis is 24 h.

 [Watch Video Solution](#)

25. Consider



The potential difference  $V_A - V_B$  is.

 [Watch Video Solution](#)

26. A particle moves in a circular path of radius  $0.5m$  at a speed that uniformly increases. Find the angular acceleration of particle if its speed changes from  $2.0m/s$  to  $4.0m/s$  in  $4.0s$



[Watch Video Solution](#)

27. A car is travelling along a circular curve that has a radius of  $50m$ . If its speed is  $16m/s$  and is increasing uniformly at  $8m/s^2$ . Determine the magnitude of its acceleration at this instant.



[Watch Video Solution](#)

28. The speed of a particle moving in a circle of radius  $r = 2m$  varies with time  $t$  as  $v = t^2$ , where  $t$  is in second and  $v$  in  $m/s$ . Find the radial, tangential and net acceleration at  $t = 2s$ .



[Watch Video Solution](#)

29. A particle moves in a circle of radius  $2\text{cm}$  at a speed given by  $v = 4t$ , where  $v$  is in  $\text{cm.s}^{-1}$  and  $t$  is in seconds.

(a) Find the tangential acceleration at  $t = 1\text{s}$

(b) Find total acceleration at  $t = 1\text{s}$ .



[Watch Video Solution](#)

30. A cyclist is riding with a speed of  $27\text{ km/h}$ . As he approaches a circular turn on the road of radius  $80\text{m}$ , he applies brakes and reduces his speed at the constant rate of  $0.50\text{m/s}$  every second. What is the magnitude and direction of the net acceleration of the cyclist on the circular turn?



[Watch Video Solution](#)

31. A ball of mass  $0.25\text{ kg}$  attached to the end of a string of length  $1.96\text{ m}$  is moving in a horizontal circle. The string will break if the tension is more than  $25\text{ N}$ . What is the maximum speed with which the ball can be moved



[Watch Video Solution](#)

**32.** A spaceman in training is rotated in a seat at the end of a horizontal arm of length 5 m. If he can withstand acceleration upto 9 g, then what is the maximum number of revolutions per second permissible? (Take,  $g = 10\text{ms}^{-2}$ )

 [Watch Video Solution](#)

**33.** A string breaks under a load of 4.8kg A mass of 0.5 kg is attached to one end of a string 2 m long and is rotated in a horizontal circle . Calculate the greatest number of revolutions that the mass can make without breaking the string .

 [Watch Video Solution](#)

**34.** A ball of mass 0.12 kg is being whirled in a horizontal circle at the end of a string 0.5 m long. It is capable of making 231 revolutions in one minute. Find the breaking tension of the string



[Watch Video Solution](#)

35. A gramophone disc rotates at 60 rpm . A coin of mass 18 g is placed at a distance of 8 cm from the centre . Calculate centrifugal force on the coin . Take  $\pi^2 = 9.87$  .



[Watch Video Solution](#)

36. Find the maximum speed at which a car can take turn round a curve of 30 cm radius on a level road if the coefficient of friction between the tyres and the road is 0.4. Take  $g = 10\text{ms}^{-2}$  .



[Watch Video Solution](#)

37. A cyclist speeding at  $4.5\text{km h}^{-1}$  on a level road takes a sharp circular turn of radius 3 m without reducing the speed The coefficient of static friction between the road and the tyres is 0.1 will the cyclist slip while

taking the turn (i) with a speed of  $405\text{km h}^{-1}$  and (ii) with a speed of  $9\text{km h}^{-1}$ ?

 [Watch Video Solution](#)

**38.** A turn of radius 600 m is banked for a vehicle of mass 200 kg going with a speed of  $180\text{km h}^{-1}$ . Determine the banking angle of its path.

 [Watch Video Solution](#)

**39.** A train has to negotiate a curve of radius 2000 m. By how much should the outer rail be raised with respect to inner rail for a speed of  $72\text{km h}^{-1}$ . The distance between the rails is 1 m.

 [Watch Video Solution](#)

**40.** A circular racetrack of radius 300 m is banked at an angle of  $15^\circ$ . The coefficient of friction between the wheels of a race car and the road is 0.2.

The optimum speed of the race car to avoid wear and tear on its tyres is



[Watch Video Solution](#)

41. A cyclist speeding at  $6ms^{-1}$  in a circle of 18 m radius makes an angle  $\theta$  with the vertical. Calculate  $\theta$ . Also determine the minimum possible value of the coefficient of friction between the tyres and the ground?



[Watch Video Solution](#)

42. A body of mass 200g tied to one end of string is revolved in a horizontal circle of radius 50cm with angular speed 60 revolution per minute (rpm) on a smooth horizontal surface. Find (a) linear speed, (b) the acceleration and (c) tension in the sting. what will happen if string is broken? (Take  $\pi^2 = 10$ )



[Watch Video Solution](#)

43. A ball of mass ( $m$ ) 0.5 kg is attached to the end of a string having length ( $L$ ) 0.5 m. The ball is rotated on a horizontal circular path about vertical axis. The maximum tension that the string can bear is 324 N. The maximum possible value of angular velocity of ball (in radian/s) is:

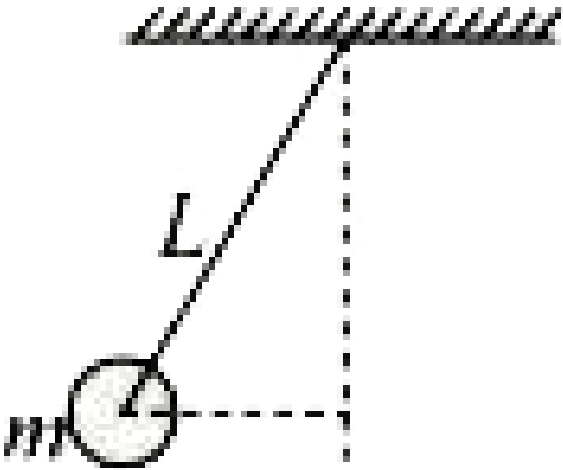

[Watch Video Solution](#)

44. A boy whirls a stone of small mass in a horizontal circle of radius  $1.5m$  and at height  $2.9m$  above level ground. The string breaks and the stone flies off horizontally and strikes the ground after travelling a



horizontal distance of  $10m$  . What is the magnitude of the centripetal acceleration of the stone while in circular motion ?



[Watch Video Solution](#)

**45.** IN a rotor, a hollow vertical cylindrical structure rotates about its axis and a person rests against the inner wall. At a particular speed of the rotor, the floor below the person is removed and the person hangs resting against the wall without any floor. If the radius of the rotor is  $2m$  and the coefficient of static friction between the wall and the person is  $0.2$ , find the minimum speed at which the floor may be removed Take  $g = 10 \frac{m}{s^2}$ .



[Watch Video Solution](#)

**46.** One end of a string of length  $1 m$  is tied to a body of mass  $0.5 kg$ . It is whirled in a vertical circle with angular frequency  $4 rad/s$ . The tension in the string, when the body is at lower most point of its motion, will be equal to (take,  $g = 10 ms^{-1}$ )



[Watch Video Solution](#)

47. A ball of mass  $0.6\text{kg}$  attached to a light inextensible string rotates in a vertical circle of radius  $0.75\text{m}$  such that it has speed of  $5\text{ms}^{-1}$  when the string is horizontal. Tension in the string when it is horizontal on other side is ( $g = 10\text{ms}^{-2}$ ).



[Watch Video Solution](#)

48. A simple pendulum is constructed by attaching a bob of mass  $m$  to a string of length  $L$  fixed at its upper end. The bob oscillates in a vertical circle. It is found that the speed of the bob is  $v$  when the string makes an angle  $\theta$  with the vertical. Find the tension in the string at this instant.



[Watch Video Solution](#)

49. A heavy particle hanging from a fixed point by a light inextensible string of length  $l$  is projected horizontally with speed  $(gl)$ . Then the

speed of the particle and the inclination of the string to the vertical at the instant of the motion when the tension in the string equal the weight of the particle-

 [Watch Video Solution](#)

50. A particle of mass  $m$  is attached to a string of length  $L$  and given velocity  $\sqrt{10gL}$  in the horizontal direction at the lowest point. Find tension in the string when the particle is at (i) lowest position (ii) highest position,

 [Watch Video Solution](#)

51. A hemispherical bowl of radius  $R$  is set rotating about its axis of symmetry which is kept vertical. A small block kept in the bowl rotates with the bowl without slipping on its surface. If the surface of the bowl is smooth, and the angle made by the radius through the block with the vertical is  $\theta$ , find the angular speed at which the bowl is rotating.

 [Watch Video Solution](#)

## Solved Examples

1. In the figure shown,  $u = \sqrt{6gR}$  ( $> \sqrt{5gR}$ )

Find  $h$ ,  $v$ ,  $a_r$ ,  $a_t$ ,  $T$  and  $F_{\text{net}}$  when

(a)  $\theta = 60^\circ$

(b)  $\theta = 90^\circ$

(c)  $\theta = 180^\circ$

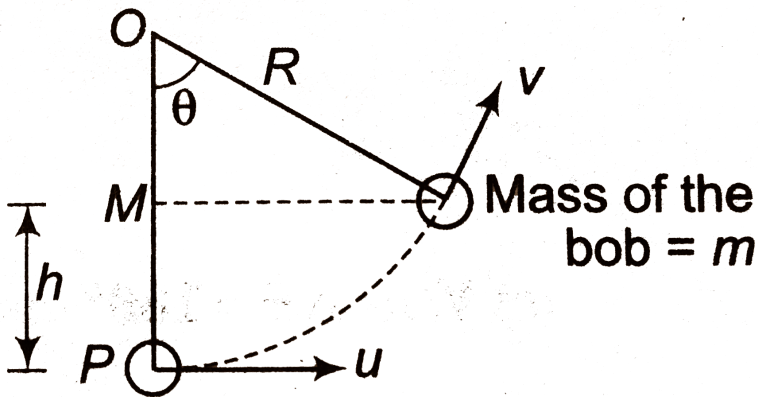

Watch Video Solution

2. A ball of mass  $m$  is released from point  $A$  where,  $\theta_0 = 53^\circ$ .

Length of pendulum is  $l$ . Find  $v$ ,  $a_r$ ,  $a_t$ ,  $a$ ,  $T$  and  $F_{net}$  at

(a) point  $A$

(b) point  $C$

(c) point  $P$  where  $\theta = 37^\circ$

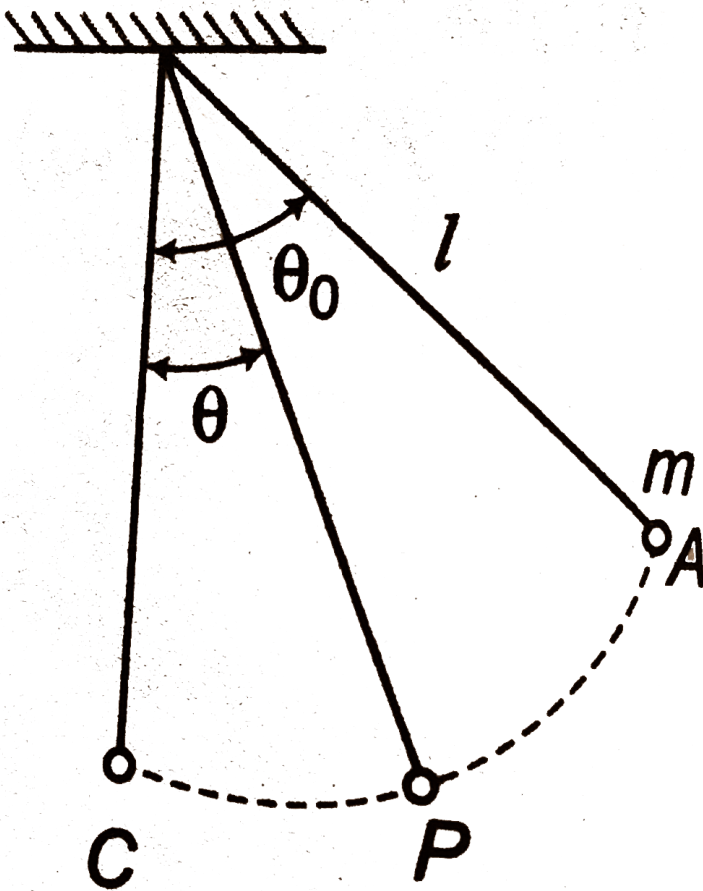

Watch Video Solution

1. A particle of mass  $m$  starts moving in a circular path of constant radius  $r$ , such that its centripetal acceleration  $a_c$  is varying with time as  $a_c = K^2 r / t^2$ , where  $K$  is a constant. What is the power delivered to the particle by the force acting on it ?

 [Watch Video Solution](#)

2. If a point moves along a circle with constant speed, prove that its angular speed about any point on the circle is half of that about the centre.

 [Watch Video Solution](#)

3. What is the radius of curvature of the parabola traced out by the projectile in the previous problem projected with speed  $v$  at an angle of  $\theta$  to the horizontal?

theta with the horizontal at a point where the particle velocity makes an angle  $\frac{\theta}{2}$  with the horizontal?

 [Watch Video Solution](#)

4. A point moves along a circle with a speed  $v = kt$ , where  $K = 0.5 \text{ m/s}^2$

Find the total acceleration of the point the moment when it has covered the  $n^{\text{th}}$  Fraction of the circle after the beginning of motion, where  $n = \frac{1}{10}$ .

 [Watch Video Solution](#)

5. In a two dimensional motion of a body, prove that tangential acceleration is nothing but component of acceleration along velocity.

 [Watch Video Solution](#)

1. Is the acceleration of particle in uniform circular motion constant or variable?

 [Watch Video Solution](#)

2. Which of the following quantities may remain constant during the motion of an object along a curved path ?

(i) Velocity

(ii) Speed

(iii) Acceleration

(iv) Magnitude of acceleration

 [Watch Video Solution](#)

3. A particle moves in a circle of radius  $1.0\text{cm}$  with a speed given by  $v = 2t$ , where  $v$  is in  $\text{cm/s}$  and  $t$  in seconds.

(a) Find the radial acceleration of the particle at  $t = 1\text{s}$ .



(b) Find the tangential acceleration of the particle at  $t = 1\text{ s}$ .

Find the magnitude of net acceleration of the particle at  $t = 1\text{ s}$ .

 [Watch Video Solution](#)

4. A particle is moving with a constant speed in a circular path. Find the ratio of average velocity to its instantaneous velocity when the particle rotates an angle  $\theta = \left(\frac{\pi}{2}\right)$ .

 [Watch Video Solution](#)

5. A particle is moving with a constant angular acceleration of  $4\text{ rad/s}^2$  in a circular path. At time  $t = 0$ , particle was at rest. Find the time at which the magnitudes of centripetal acceleration and tangential acceleration are equal.

 [Watch Video Solution](#)

6. A particle is rotates in a circular path of radius  $54m$  with varying speed  $v = 4t^2$  . Here  $v$  is in  $m/s$  and  $t$  inn second . Find angle between velocity and acceleeration at  $t = 3s$  .



[Watch Video Solution](#)

7. Figur shows the total acceleration and velocity of a particle moving clockwise in a circle of radius  $2.5m$  at a given instant of time. At this instant, find:

- (a) the radius acceleration,
- (b) the speed of the acceleration,

(c) its tangential acceleration.

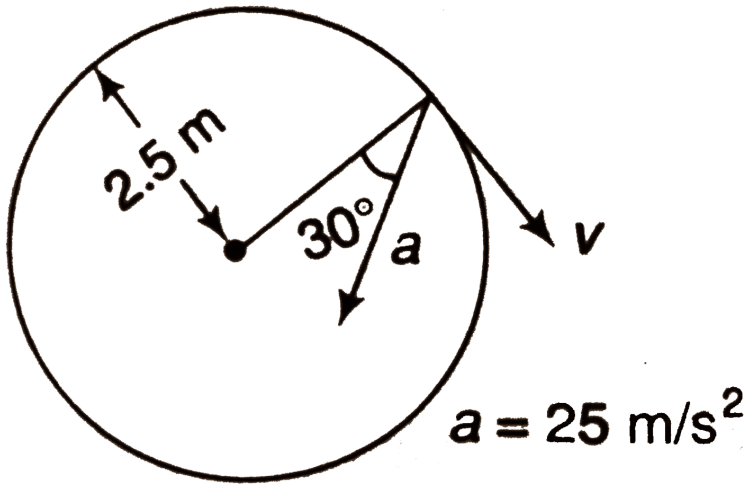

[▶ Watch Video Solution](#)

## Exercise 10.2

1. A turn has a radius of  $10\text{m}$  if a vehicle goes round it at an average speed of  $18\text{km/h}$ , what should be the proper angle of banking?

[▶ Watch Video Solution](#)

2. If the road of the previous problem is horizontal (no banking), what should be the minimum friction coefficient so that a scooter going at  $18\text{ km/h}$  does not skid?

 [Watch Video Solution](#)

3. A circular road of radius  $50\text{ m}$  has the angle of banking equal to  $30^\circ$ . At what should a vehicle go on this road so that the friction is not used?

 [Watch Video Solution](#)

4. Is a body in uniform circular motion in equilibrium?

 [Watch Video Solution](#)

5. A car driver going at speed  $v$  suddenly finds a wide wall at a distance  $r$ . Should he apply brakes or turn the car in a circle of radius  $r$  to avoid

hitting the wall.

[▶ Watch Video Solution](#)

6. A  $4\text{ kg}$  block is attached to a vertical rod by means of two strings of equal length. When the system rotates about the axis of the rod, the strings are extended as shown in figure.

(a) How many revolutions per minute must the system make in order for the tension in the upper string to be  $200\text{ N}$  ?

(b) What is the tension in the lower string then ?

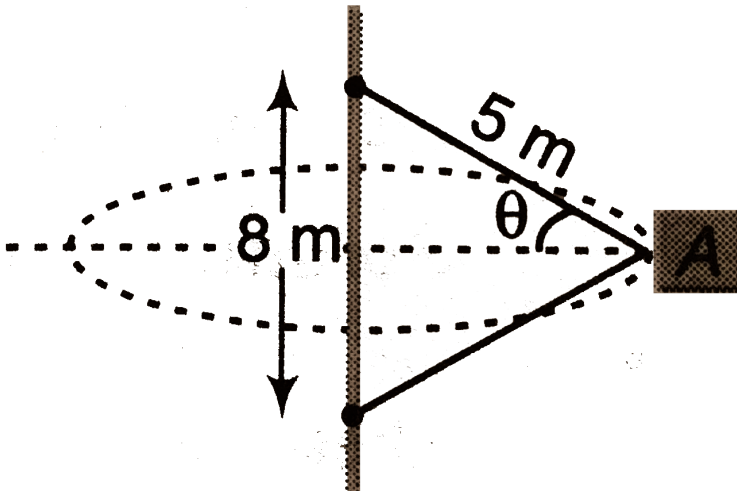

[▶ Watch Video Solution](#)

7. A car moves at a constant speed on a straight but hilly road. One section has a crest and dip of the  $250m$  radius.

(a) As the car passes over the crest the normal force on the car is half the  $16kN$  weight of the car. What will the normal force on the car as it passes through the bottom of the dip?

(b) What is the greatest speed at which the car can move without leaving the road at the top of the hill?

(c) Moving at a speed found in part (b) what will be the normal force on the car as it moves through the bottom of the dip? (Take,  $g = 10m/s^2$ )



[Watch Video Solution](#)

### Exercise 10.3

1. In the figure shown in fig. 10.33, a bob attached with a light string of radius  $R$  is given an initial velocity  $u = \sqrt{4gR}$  at the bottommost point.

(a) At what height will the string be slack.

(b) What is velocity of the bob just before slacking of string.

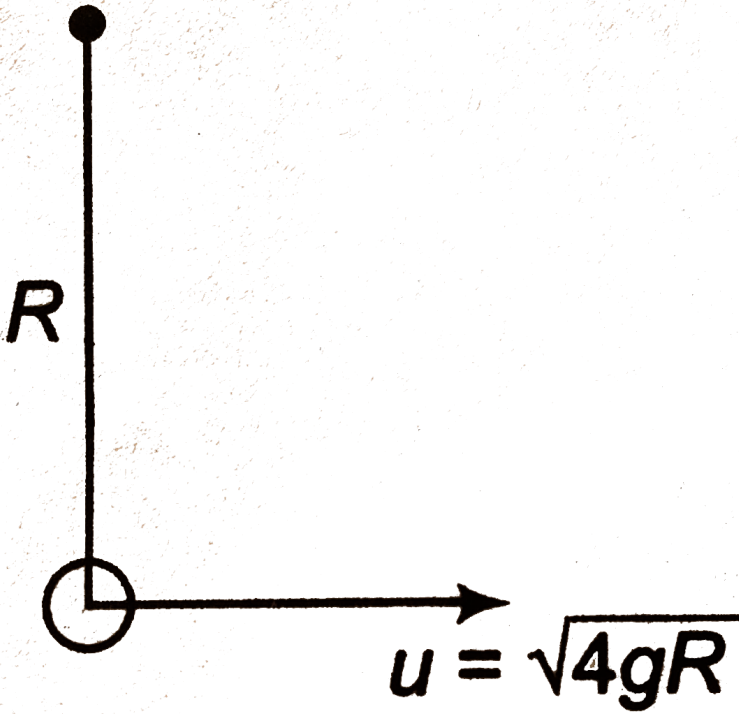

[Watch Video Solution](#)

2. In the above question, if  $u = \sqrt{gR}$  then

(a) after rotating an angle  $\theta$ , velocity of the bob becomes zero. Find the value of  $\theta$ .

(b) If mass of the bob is ' $m$ ' then what is the tension in the string when velocity becomes zero?



Watch Video Solution

3. The bob rotates in a circular path ,if  $u = \sqrt{7gR}$  then It

(a) What is the velocity at topmost point?

(b) What is tension at topmost point?

(c) What is tension at bottommost point?



Watch Video Solution

4. A bob is suspended from a crane by a cable of length  $l = 5m$  . The crane and load are moving at a constant speed  $v_0$  . The crane is stopped by a bumper and the cable swings out an angle of  $60^\circ$  . Find the initial speed  $v_0$ . ( $g = 9.8m/s^2$ )







## Assertion And Reason

1. Assertion: A particle is rotating in a circle with constant speed as shown. Between point  $A$  and  $B$ , ratio of average acceleration and average velocity  $v$  can be stopped in a minimum distance  $d$ . If the same car, moving with same speed  $v$  takes a circular turn, then minimum safe radius can be  $2d$ .

Reason:  $d = \frac{v^2}{2\mu g}$  and minimum safe radius  $= \frac{v^2}{\mu g}$

- A. If both Assertion and Reason are true and the Reason is correct explanation of the Assertion.
- B. If both Assertion and Reason are true but Reason is not the correct explanation of Assertion.
- C. If Assertion is true, true but the Reason is false.
- D. If Assertion is false but the Reason is true.

Answer: B

 Watch Video Solution

2. Assertion: A particle is rotating in a circle with constant speed as shown. Between point  $A$  and  $B$ , ratio of average acceleration and average velocity is angular velocity of particle about point  $O$ .

Reason: Since speed is constant, angular velocity is also constant.

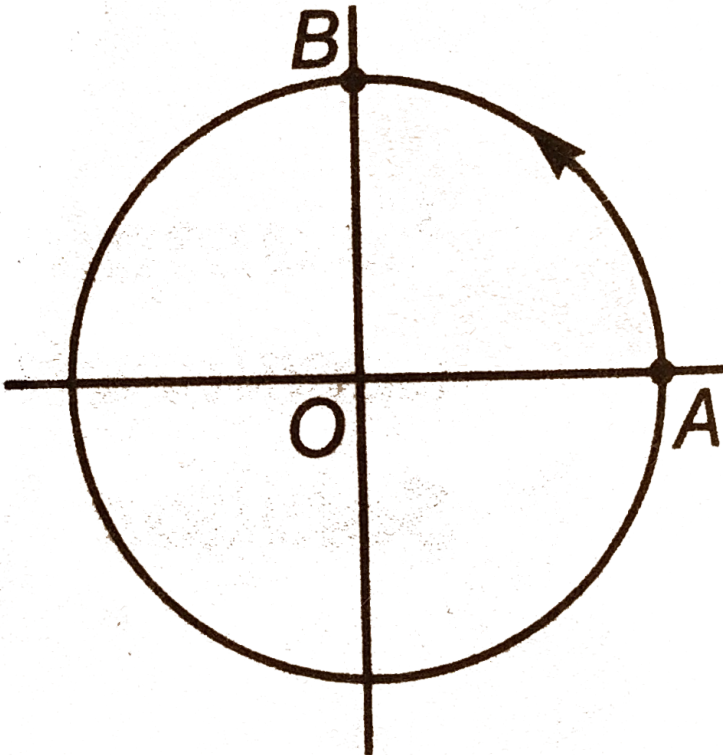

- A. If both Assertion and Reason are true and the Reason is correct explanation of the Assertion.
- B. If both Assertion and Reason are true but Reason is not the correct explanation of Assertion.
- C. If Assertion is true, true but the Reason is false.
- D. If Assertion is false but the Reason is true.

**Answer: B**



**Watch Video Solution**

**3. Assertion:** A frame moving in a circle with constant speed can never be an inertial frame.

**Reason:** It has a constant acceleration.

- A. If both Assertion and Reason are true and the Reason is correct explanation of the Assertion.

B. If both Assertion and Reason are true but Reason is not the correct explanation of Assertion.

C. If Assertion is true, true but the Reason is false.

D. If Assertion is false but the Reason is true.

**Answer: C**



[Watch Video Solution](#)

4. Assertion: In circular motion, dot product of velocity vector ( $v$ ) and acceleration vector ( $a$ ) may be positive, negative or zero.

Reason: Dot product of angular velocity vector and linear velocity vector is always zero.

A. If both Assertion and Reason are true and the Reason is correct explanation of the Assertion.

B. If both Assertion and Reason are true but Reason is not the correct explanation of Assertion.

C. If Assertion is true, true but the Reason is false.

D. If Assertion is false but the Reason is true.

**Answer: B**



[Watch Video Solution](#)

5. Assertion: Velocity and acceleration of a particle in circular motion at some instant are:

$$v = (2\hat{i})ms^{-1} \text{ and } a = (-\hat{i} + 2\hat{j})ms^{-2}, \text{ then radius of circle is } 2m.$$

Reason: Speed of particle is decreasing at a rate of  $1ms^{-2}$ .

A. If both Assertion and Reason are true and the Reason is correct explanation of the Assertion.

B. If both Assertion and Reason are true but Reason is not the correct explanation of Assertion.

C. If Assertion is true, true but the Reason is false.

D. If Assertion is false but the Reason is true.

Answer: B

[▶ Watch Video Solution](#)

6. Assertion: In vertical circular motion, acceleration of bob at position  $A$  is greater than ' $g$ '.

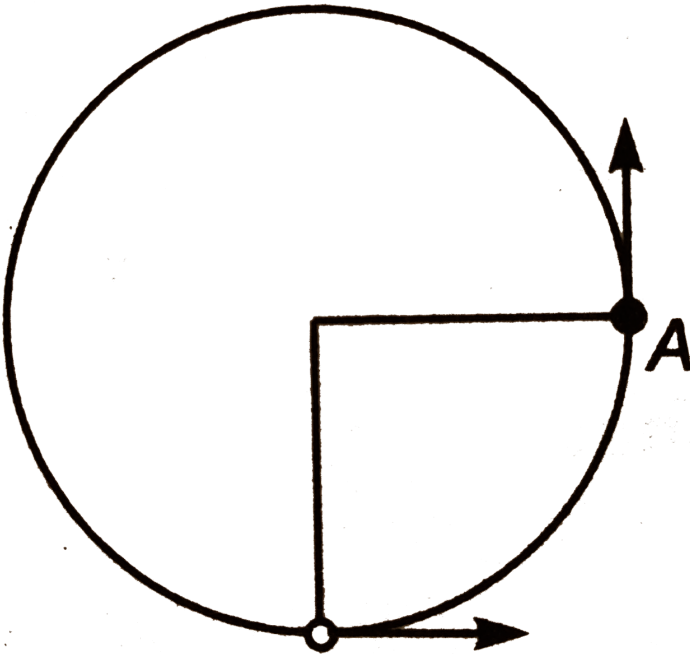

Reason: Net acceleration at  $A$  is resultant of tangential and radial components of acceleration.

- A. If both Assertion and Reason are true and the Reason is correct explanation of the Assertion.
- B. If both Assertion and Reason are true but Reason is not the correct explanation of Assertion.
- C. If Assertion is true, true but the Reason is false.
- D. If Assertion is false but the Reason is true.

**Answer: A**



**Watch Video Solution**

7. Assertion: A pendulum is oscillating between points  $A$ ,  $B$  and  $C$ .  
Acceleration of bob at points  $A$  or  $C$  is zero.

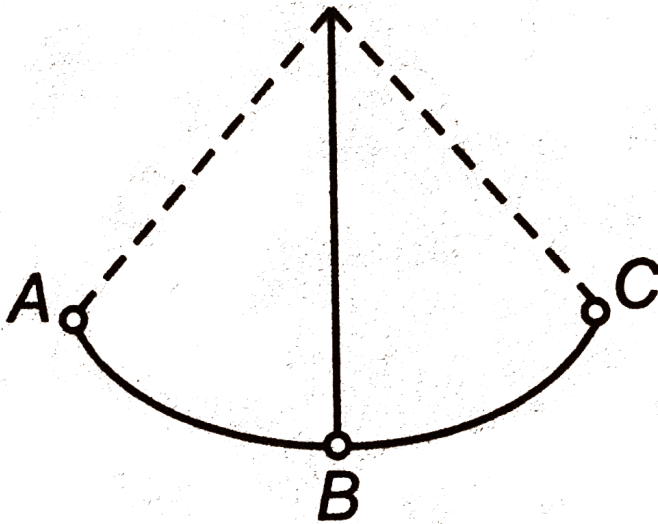

Reason: Velocity at these points is zero.

- A. If both Assertion and Reason are true and the Reason is correct explanation of the Assertion.
- B. If both Assertion and Reason are true but Reason is not the correct explanation of Assertion.
- C. If Assertion is true, true but the Reason is false.
- D. If Assertion is false but the Reason is true.

Answer: D



Watch Video Solution



8. Assertion: Speed of a particle moving in a circle varies with time as,  $u = (4t - 12)$ . Such type of circular motion is not possible.

Reason: Speed cannot change linearly with time.

- A. If both Assertion and Reason are true and the Reason is correct explanation of the Assertion.
- B. If both Assertion and Reason are true but Reason is not the correct explanation of Assertion.
- C. If Assertion is true, true but the Reason is false.
- D. If Assertion is false but the Reason is true.

**Answer: C**



Watch Video Solution

9. Assertion: Circular and projectile motions both are two dimensional motion. But In circular motion, we cannot apply  $v = u + at$  directly, whereas in projectile motion we can.

Reason: Projectile motion takes place under gravity, while in circular motion gravity has no role.

- A. If both Assertion and Reason are true and the Reason is correct explanation of the Assertion.
- B. If both Assertion and Reason are true but Reason is not the correct explanation of Assertion.
- C. If Assertion is true, true but the Reason is false.
- D. If Assertion is false but the Reason is true.

**Answer: C**



**Watch Video Solution**

10. Assertion: A particle of mass  $m$  takes uniform horizontal circular motion inside a smooth funnel as shown. Normal reaction in this case is not  $mg \cos \theta$ .

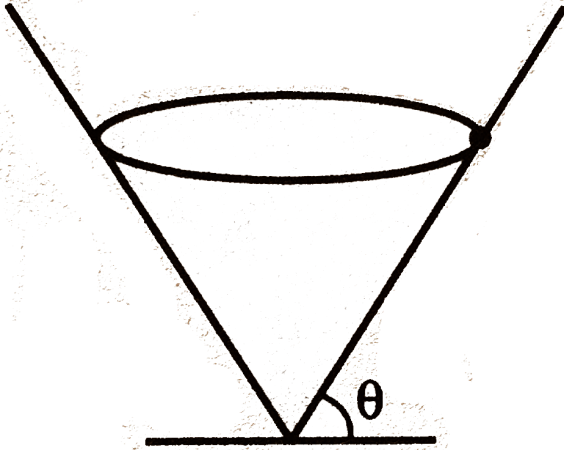

Reason: Acceleration of particle is not along the surface of funnel.

- A. If both Assertion and Reason are true and the Reason is correct explanation of the Assertion.
- B. If both Assertion and Reason are true but Reason is not the correct explanation of Assertion.
- C. If Assertion is true, true but the Reason is false.
- D. If Assertion is false but the Reason is true.

**Answer: A**



[Watch Video Solution](#)

**11. Assertion:** When water in a bucket is whirled fast overhead, the water does not fall out at the top of the circular path.

**Reason:** The centripetal force in this position on water is more than the weight of water.

- A. If both Assertion and Reason are true and the Reason is correct explanation of the Assertion.
- B. If both Assertion and Reason are true but Reason is not the correct explanation of Assertion.
- C. If Assertion is true, true but the Reason is false.
- D. If Assertion is false but the Reason is true.

**Answer: A**



[Watch Video Solution](#)

12. Two fixed frictionless inclined planes making angles  $30^\circ$  and  $60^\circ$  with the vertical are shown in the figure. Two blocks A and B are placed on the two planes. What is the relative vertical acceleration of A with respect to B?

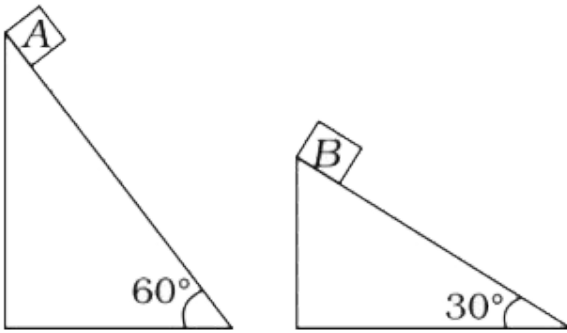

A.  $90^\circ, \cos^{-1}\left(\frac{1}{\sqrt{3}}\right)0^\circ$

B.  $0^\circ, \cos^{-1}\sqrt{3}, 90^\circ$

C.  $0^\circ, \cos^{-1}\sqrt{3}, 90^\circ$

D.  $\cos^{-1}\left(\frac{1}{\sqrt{3}}\right)90^\circ, 0^\circ$



Watch Video Solution

13. On a frictionless horizontal surface, assumed to be the  $x - y$  plane, a small trolley  $A$  is moving along a straight line parallel to the  $y -$  axis (see figure) with a constant velocity of  $(\sqrt{3} - 1)m/s$ . At a particular instant, when the line  $OA$  makes an angle of  $45^\circ$  with the  $x -$  axis, a ball is thrown along the surface from the origin  $O$ . Its velocity makes an angle  $\phi$  with the  $x -$  axis and it hits the trolley.

(a) The motion of the ball is observed from the frame of the trolley.

Calculate the angle  $\theta$  made by the velocity vector of the ball with the  $x -$  axis in this frame.

(b) Find the speed of the ball with respect to the surface, if

$$\phi = (4\theta) / (3).$$

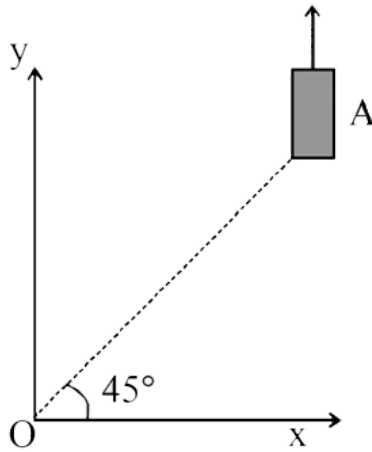

A.  $\sin^{-1}\left(\frac{u^2}{3gR} + \frac{2}{3}\right)$

B.  $\cos^{-1}\left(\frac{u^2}{3gR} + \frac{2}{3}\right)$

C.  $\cos^{-1}\left(\frac{u^2}{6gR} + \frac{4}{3}\right)$

D.  $\sin^{-1}\left(\frac{u^2}{6gR} + \frac{2}{3}\right)$



Watch Video Solution

**14.** Assertion : A uniform circular motion is an accelerated motion.

Reason : Direction of acceleration is parallel to be velocity vector.

- A. If both Assertion and Reason are correct and Reason is the correct explanation of Assertion.
- B. If both Assertion and Reason are correct but Reason is not the correct explanation of Assertion.
- C. If Assertion is true but Reason is false.
- D. If Assertion is false but Reason is true.

**Answer: D**



**Watch Video Solution**

**15.** Assertion In circular motion, dot product of  $v$  and  $\omega$  is always zero.

Reason  $\omega$  is always perpendicular to the plane of the circular motion.

- A. If both Assertion and Reason are correct and Reason is the correct explanation of Assertion.



B. If both Assertion and Reason are correct but Reason is not the correct explanation of Assertion.

C. If Assertion is true but Reason is false.

D. If Assertion is false but Reason is true.

**Answer: A**

 [Watch Video Solution](#)

**16. STATEMENT -1 :** In non - uniform circular motion acceleration of a particles is along the tangent of the circle .

**STATEMENT -2 :** In uniform circular motion acceleration of a particle is zero .

**STATEMENT -3 :** In no - uniform circular motion acceleration of a particle is towards the centre of the circle.

A. If both Assertion and Reason are correct and Reason is the correct explanation of Assertion.

B. If both Assertion and Reason are correct but Reason is not the correct explanation of Assertion.

C. If Assertion is true but Reason is false.

D. If Assertion is false but Reason is true.

**Answer: D**

 [Watch Video Solution](#)

17. Assertion In circular motion, average speed and average velocity are never equal.

Reason In any curvilinear path, these two are never equal.

A. If both Assertion and Reason are correct and Reason is the correct explanation of Assertion.

B. If both Assertion and Reason are correct but Reason is not the correct explanation of Assertion.

C. If Assertion is true but Reason is false.

D. If Assertion is false but Reason is true.

**Answer: A**

 [Watch Video Solution](#)

**18.** Assertion A particle is rotating in a circle of radius 1 m. At some given instant, its speed is  $2\text{ms}^{-1}$ . Then acceleration of particle at the given instant is  $4\text{ms}^{-2}$ .

Reason Centripetal acceleration at this instant is  $4\text{ms}^{-2}$  towards centre of circle.

A. If both Assertion and Reason are correct and Reason is the correct explanation of Assertion.

B. If both Assertion and Reason are correct but Reason is not the correct explanation of Assertion.

C. If Assertion is true but Reason is false.

D. If Assertion is false but Reason is true.

**Answer: B**



[Watch Video Solution](#)

**19.** Assertion Centripetal force  $(mv^2) / (R)$  acts on a particle rotating in a circle.

Reason Summation of net force acting on the particle is equal to  $(mv^2) / (R)$  in the above case.

- A. If both Assertion and Reason are correct and Reason is the correct explanation of Assertion.
- B. If both Assertion and Reason are correct but Reason is not the correct explanation of Assertion.
- C. If Assertion is true but Reason is false.
- D. If Assertion is false but Reason is true.

**Answer: A**



[Watch Video Solution](#)

**20.** Assertion If a particle is rotating in a circle, then centrifugal force is acting on the particle in radially outward direction .

Reason centrifugal force is equal and opposite to the centripetal force.

- A. If both Assertion and Reason are correct and Reason is the correct explanation of Assertion.
- B. If both Assertion and Reason are correct but Reason is not the correct explanation of Assertion.
- C. If Assertion is true but Reason is false.
- D. If Assertion is false but Reason is true.

**Answer: A**



[Watch Video Solution](#)

**21. Assertion** When a car takes a circular turn on a horizontal road, then normal reaction on inner wheels is always less than the normal reaction on outer wheels.

**Reason** This is for rotational equilibrium of car.

- A. If both Assertion and Reason are correct and Reason is the correct explanation of Assertion.
- B. If both Assertion and Reason are correct but Reason is not the correct explanation of Assertion.
- C. If Assertion is true but Reason is false.
- D. If Assertion is false but Reason is true.

**Answer: D**



**Watch Video Solution**

**22. Assertion** When water in a bucket is whirled fast overhead, the water does not fall out at the top of the circular path.

**Reason** The centripetal force in this position on water is more than the weight of water.

- A. If both Assertion and Reason are correct and Reason is the correct explanation of Assertion.
- B. If both Assertion and Reason are correct but Reason is not the correct explanation of Assertion.
- C. If Assertion is true but Reason is false.
- D. If Assertion is false but Reason is true.

**Answer: A**



[Watch Video Solution](#)

**23.** Assertion In circular motion, average speed and average velocity are never equal.

Reason In any curvilinear path, these two are never equal.

- A. If both Assertion and Reason are correct and Reason is the correct explanation of Assertion.
- B. If both Assertion and Reason are correct but Reason is not the correct explanation of Assertion.
- C. If Assertion is true but Reason is false.
- D. If Assertion is false but Reason is true.

**Answer: A**



[Watch Video Solution](#)

**24.** Assertion Angle ( $\theta$ ) between  $a$  and  $v$  in circular motion is

$$0^\circ < \theta < 180^\circ$$



Reason Angle between any two vectors lies in the above range.

- A. If both Assertion and Reason are correct and Reason is the correct explanation of Assertion.
- B. If both Assertion and Reason are correct but Reason is not the correct explanation of Assertion.
- C. If Assertion is true but Reason is false.
- D. If Assertion is false but Reason is true.

**Answer: C**



[Watch Video Solution](#)

**25.** Assertion A ball tied by thread is undergoing circular motion (of radius  $R$ ) in a vertical plane. (Thread always remains in vertical plane). The difference of maximum and minimum tension in thread is independent of speed ( $u$ ) of ball at the lowest position ( $u > \sqrt{5gR}$ ).

Reason For a ball of mass  $m$  tied by thread undergoing vertical circular

motion (of radius  $R$ ), difference in maximum and minimum magnitude of centripetal acceleration of the ball is independent of speed ( $u$ ) of ball at the lowest position ( $u_{gr}\sqrt{5gR}$ ).

- A. (a)Both Assertion and Reason are correct and Reason is the correct explanation of Assertion.
- B. If both Assertion and Reason are correct but Reason is not the correct explanation of Assertion.
- C. If Assertion is true but Reason is false.
- D. If Assertion is false but Reason is true.

**Answer: A**



**Watch Video Solution**

**26.** Assertion One end of a massless rod of length  $l$  is hinged so that it is free to rotate in vertical plane about a horizontal axis. If a particle is attached to the other end of the rod, then the minimum speed at lower

most position of the particle is  $\sqrt{5gl}$  to complete the circular motion.

Reason Work done by centripetal force on the particle is always zero.

- A. If both Assertion and Reason are correct and Reason is the correct explanation of Assertion.
- B. If both Assertion and Reason are correct but Reason is not the correct explanation of Assertion.
- C. If Assertion is true but Reason is false.
- D. If Assertion is false but Reason is true.

**Answer: D**



[Watch Video Solution](#)

**27. Assertion** A car moves along a road with uniform speed. The path of car lies in vertical plane and shown in figure. The radius of curvature (R) of the path is same everywhere. If the car does not lose contact with road at the highest point, it can travel the shown path without losing

contact with road anywhere else.

Reason For car to loose contact with road, the normal reaction between car and road should be zero.

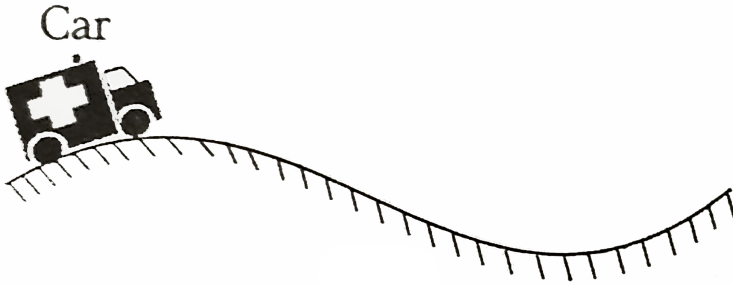

- A. If both Assertion and Reason are correct and Reason is the correct explanation of Assertion.
- B. If both Assertion and Reason are correct but Reason is not the correct explanation of Assertion.
- C. If Assertion is true but Reason is false.
- D. If Assertion is false but Reason is true.

**Answer: D**



**Watch Video Solution**

28. Assertion A small block of mass  $m$  is rotating in a circle inside a smooth cone as shown in figure. In this case the normal reaction,

$$N \neq mg \cos \theta$$

Reason In this case, acceleration of the block is not along the surface of cone. It is horizontal.

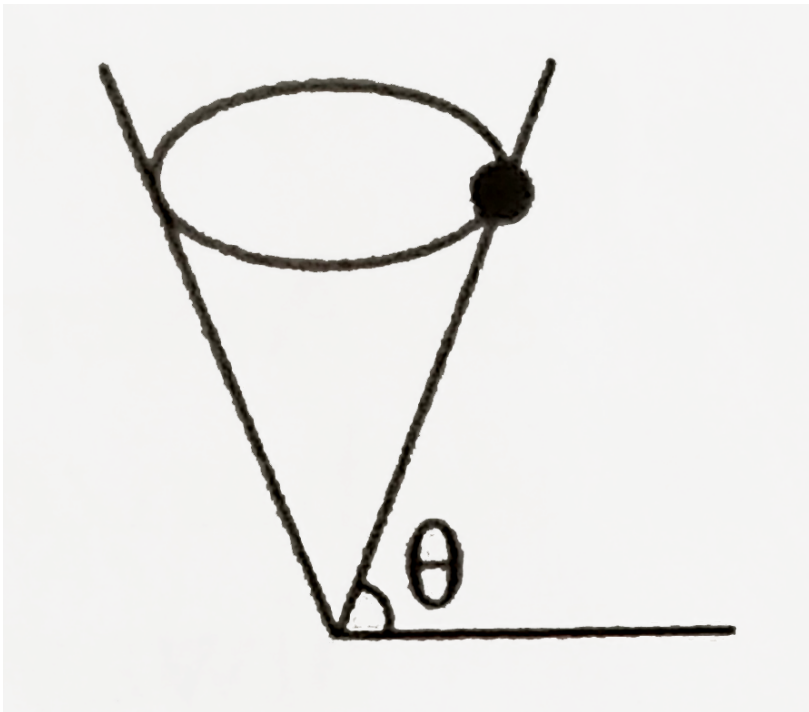

A. If both Assertion and Reason are correct and Reason is the correct explanation of Assertion.

B. If both Assertion and Reason are correct but Reason is not the correct explanation of Assertion.

C. If Assertion is true but Reason is false.

D. If Assertion is false but Reason is true.

**Answer: A**

 [Watch Video Solution](#)

## Level 1 Objective

1. A particle is revolving in a circle with increasing its speed uniformly.

Which of the following is constant ?

A. Centripetal acceleration

B. Tangential acceleration

C. Angular acceleration

D. None of these

**Answer: C**



**Watch Video Solution**

2. A particle is moving in a circular path with a constant speed. If  $\theta$  is the angular displacement, then starting from  $\theta = 0$ , the maximum and minimum change in the linear momentum will occur when value of  $\theta$  is respectively

- A.  $45^\circ$  and  $90^\circ$
- B.  $90^\circ$  and  $180^\circ$
- C.  $180^\circ$  and  $360^\circ$
- D.  $90^\circ$  and  $270^\circ$

**Answer: C**



**Watch Video Solution**

3. A simple pendulum of length  $l$  has maximum angular displacement  $\theta$  .

Then maximum kinetic energy of a bob of mass  $m$  is

A.  $\frac{1}{2}mgl$

B.  $\frac{1}{2}mgl \cos \theta$

C.  $mgl(1 - \cos \theta)$

D.  $\frac{1}{2}mgl \sin \theta$

**Answer: C**



[Watch Video Solution](#)

4. A particle of mass  $m$  is fixed to one end of a light rigid rod of length  $l$  and rotated in a vertical circular path about its other end. The minimum speed of the particle at its highest point must be

A. zero

B.  $\sqrt{gl}$



C.  $\sqrt{1.5gl}$

D.  $\sqrt{2gl}$

**Answer: A**



**Watch Video Solution**

5. A simple pendulum of length  $l$  and mass  $m$  is initially at its lowest position. It is given the minimum horizontal speed necessary after to move in a circular path about the point of suspension. The tension in the string at the lowest position of the bob is

A.  $3mg$

B.  $4mg$

C.  $5mg$

D.  $6mg$

**Answer: D**



**Watch Video Solution**

6. A point moves along a circle having a radius  $20\text{cm}$  with a constant tangential acceleration  $5\text{cm} / \text{s}^2$ . How much time is needed after motion begins for the normal acceleration of the point to be equal to tangential acceleration?

A.  $1\text{s}$

B.  $2\text{s}$

C.  $3\text{s}$

D.  $4\text{s}$

**Answer: B**

[Watch Video Solution](#)

7. A ring of mass  $(2\pi)\text{kg}$  and of radius  $0.25\text{m}$  is making  $300\text{rpm}$  about an axis through its perpendicular to its plane. The tension in newton

developed in ring is approximately a) 50 b) 100 c) 175 d) 247

A. 50

B. 100

C. 175

D. 250

**Answer: D**



[Watch Video Solution](#)

8. A car is moving on a circular level road of curvature  $300m$  . If the coefficient of friction is  $0.3$  and acceleration due to gravity is  $10m/s^2$  , the maximum speed of the car be a)  $90\text{ km/h}$  b)  $81\text{ km/h}$  c)  $108\text{ km/h}$  d)  $162\text{ km/h}$

A.  $90Km/h$

B.  $81Km/h$

C.  $108Km/h$

D.  $162Km/h$

**Answer: C**



**Watch Video Solution**

9. In a conical pendulum arrangement, a string of length 1 m is fixed at one end with a bob of mass 100 g and the string makes  $2\pi$  r v s<sup>-1</sup> around a vertical axis through a fixed point. The angle of inclination of the string with vertical is: (Take  $g = 10 \text{ m s}^{-2}$ )

A.  $\tan^{-1}\left(\frac{5}{8}\right)$

B.  $\tan^{-1}\left(\frac{3}{5}\right)$

C.  $\cos^{-1}\left(\frac{3}{5}\right)$

D.  $\cos^{-1}\left(\frac{5}{8}\right)$

**Answer: D**



**Watch Video Solution**

10. In the previous question the tension in the string is

A.  $\frac{5}{8}N$

B.  $\frac{8}{5}N$

C.  $\frac{50}{8}N$

D.  $\frac{80}{5}N$

**Answer: B**



[Watch Video Solution](#)

11. A small particle of mass  $0.36g$  rests on a horizontal turntable at a distance  $25cm$  from the axis of spindle. The turntable is acceleration at rate of  $\alpha = \frac{1}{3}rads^{-2}$ . The frictional force that the table exerts on the particle  $2s$  after the startup is

A.  $40\mu N$

B.  $30\mu N$

C.  $50\mu N$

D.  $60\mu N$

**Answer: C**



**Watch Video Solution**

12. A simple pendulum of length  $l$  and bob of mass  $m$  is displaced from its equilibrium position  $O$  to a position  $P$  so that height of  $P$  above  $O$  is  $h$ . If is then released. What is the tension in the string when the bob passes through the through the equilibrium position  $O$ ? Neglect friction.  $v$  is the velocity of the bob at  $O$

A.  $m\left(g + \frac{v^2}{l}\right)$

B.  $\frac{2mgh}{l}$

C.  $mg\left(1 + \frac{h}{l}\right)$

D.  $mg\left(1 + \frac{2h}{l}\right)$

**Answer: D**



[Watch Video Solution](#)

13. Two particles revolve concentrically in a horizontal plane in the same direction. The time required to complete one revolution for particle  $A$  is  $3 \text{ min}$  , while for particle  $B$  is  $1 \text{ min}$  . The time required for  $A$  to complete one revolution relative to  $B$  is

A.  $2 \text{ min}$

B.  $1 \text{ min}$

C.  $1.5 \text{ min}$

D.  $1.25 \text{ min}$

**Answer: C**



[Watch Video Solution](#)

14. Three particles  $A$ ,  $B$  and  $C$  move in a circle in anticlockwise direction with speeds  $1 \text{ min}^{-1}$ ,  $2.5 \text{ m s}^{-1}$  and  $2 \text{ m s}^{-1}$  respectively. The initial

positions of  $A$ ,  $B$  and  $C$  shown in figure . the ratio of distance travelled by  $A$ ,  $B$  and  $C$  by the instant they meet for the first time is

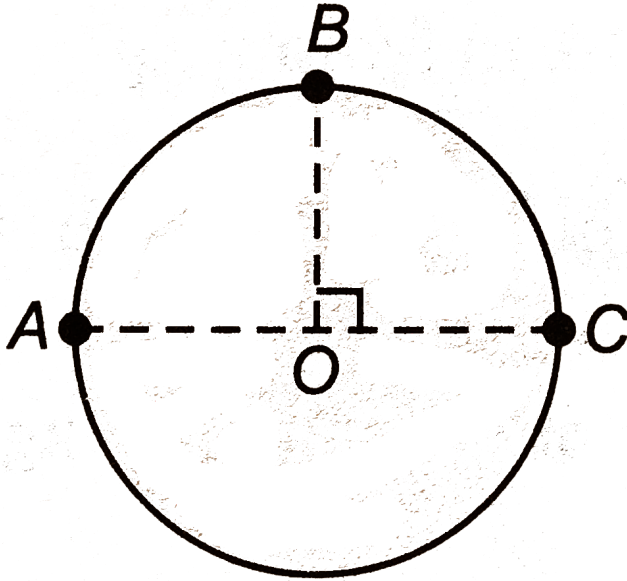

A. 3 : 2

B. 5 : 4

C. 3 : 5

D. data insufficient

**Answer: B**



**Watch Video Solution**



1. A car is travelling along a circular curve that has a radius of  $50m$  . If its speed is  $16m/s$  and is increasing uniformly at  $8m/s^2$  . Determine the magnitude of its acceleration at this instant.

 [Watch Video Solution](#)

2. A  $70kg$  man stands in contact against the inner wall of a hollow cylindrical drum of radius  $3m$  rotating about its vertical axis. The coefficient of friction between the wall and his clothing is  $0.15$  . What is the minimum rotational speed of the cylinder to enable the man to remain stuck to the wall (without falling) when the floor is suddenly removed?

 [Watch Video Solution](#)

3. A particle is projected with a speed  $u$  at angle  $\theta$  with the horizontal. Consider a small part of its path near the highest position and take it approximately to be a circular arc. What is the radius of this circle? This radius is called the adius of curvature of the curve at the point.

 [Watch Video Solution](#)

4. Find the maximum speed at which a truck can safely travel without toppling over, on a curve of radius  $250m$  . The height of the centre of gravity of the truck above the ground is  $1.5m$  and the distance between the wheels is  $1.5m$  , the truck being horizontal.

 [Watch Video Solution](#)

5. A hemispherical bowl of radius  $R$  is set rotating about its axis of symmetry which is kept vertical. A small block kept in the bowl rotates with the bowl without slipping on its surface. If the surfaces of the bowl

is smooth, and the angle made by the radius through the block with the vertical is  $\theta$ , find the angular speed at which the bowl is rotating.

 [Watch Video Solution](#)

6. Show that the angle made by the string with the vertical in a conical pendulum is given by  $\cos \theta = \frac{g}{L\omega^2}$ , where  $L$  is the string and  $\omega$  is the angular speed.

 [Watch Video Solution](#)

7. A boy whirls a stone of small mass in a horizontal circle of radius  $1.5m$  and at height  $2.9m$  above level ground. The string breaks and the stone flies off horizontally and strikes the ground after travelling a horizontal distance of  $10m$ . What is the magnitude of the centripetal acceleration of the stone while in circular motion ?

A.  $33ms^{-2}$

B.  $63ms^{-2}$

C.  $93ms^{-2}$

D.  $113ms^{-2}$

**Answer: A::B::C**



**Watch Video Solution**

8. A block of mass  $m$  is kept on a horizontal ruler. The friction coefficient between the ruler and the block is  $\mu$ . The ruler is fixed at one end and the block is at a distance  $L$  from the fixed end. The ruler is rotated about the fixed end in the horizontal plane through the fixed end.

a. What can the maximum angular speed of the ruler b) if the angular speed of ruler is uniformly increased from zero to an angular acceleration  $\alpha$ , at what angular speed will the block slip?



**Watch Video Solution**

9. A thin circular wire of radius  $R$  rotates about its vertical diameter with an angular frequency  $\omega$ . Show that a small bead on the wire remain at its lowermost point for  $\omega \leq \sqrt{g/R}$ . What is angle made by the radius vector joining the centre to the bead with the vertical downward direction for  $\omega = \sqrt{2g/R}$ ? Neglect friction.

A. 60

B. 30

C. 90

D. 0



Watch Video Solution

10. Two block tied with a massless string of length  $3m$  are placed on a rotating table as shown. The axis of rotation is  $1m$  from  $1kg$  mass and  $2m$  from  $2kg$  mass. The angular speed  $\omega = 4rad/s$ . Ground below  $2kg$  block is smooth and below  $1kg$  block is rough. ( $g = 10m/s^2$ )

(a) Find tension in the string, force of friction on  $1\text{kg}$  block and its direction.

(b) If coefficient of friction between  $1\text{kg}$  block and ground is  $\mu = 0.8$ . Find maximum angular speed so that neither of the blocks slips.

(c) If maximum tension in the string can be  $100\text{N}$ , then maximum angular speed so that neither of the blocks slips.

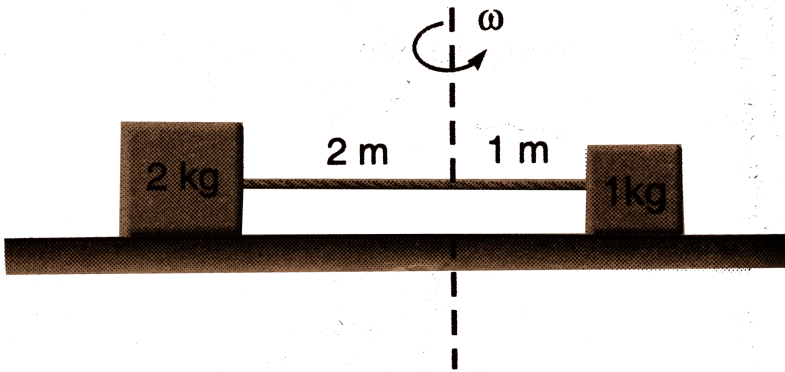

[Watch Video Solution](#)

11. A small block slides with velocity  $0.5\sqrt{gr}$  on the horizontal frictionless surface as shown in the figure. The block leaves the surface at point  $C$ .

Calculate angle  $\theta$  in the figure.

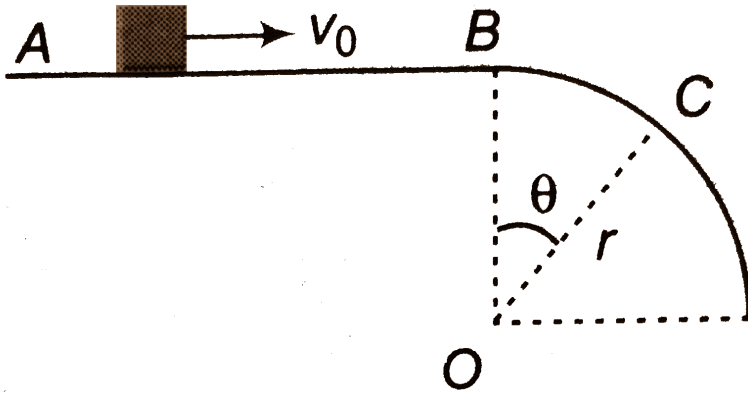

A.  $\cos^{-1}\left(\frac{3}{4}\right)$

B.  $\cos^{-1}\left(\frac{4}{9}\right)$

C.  $\cos^{-1}\left(\frac{1}{4}\right)$

D.  $\cos^{-1}\left(\frac{5}{4}\right)$

**Answer: A::C::D**



**Watch Video Solution**

12. The bob of the pendulum shown in figure describes an arc of a circle in a vertical plane. If the tension in the cord is 2.5 times the weight of the

bob for the position shown. Find the velocity and the acceleration of the bob in that position.

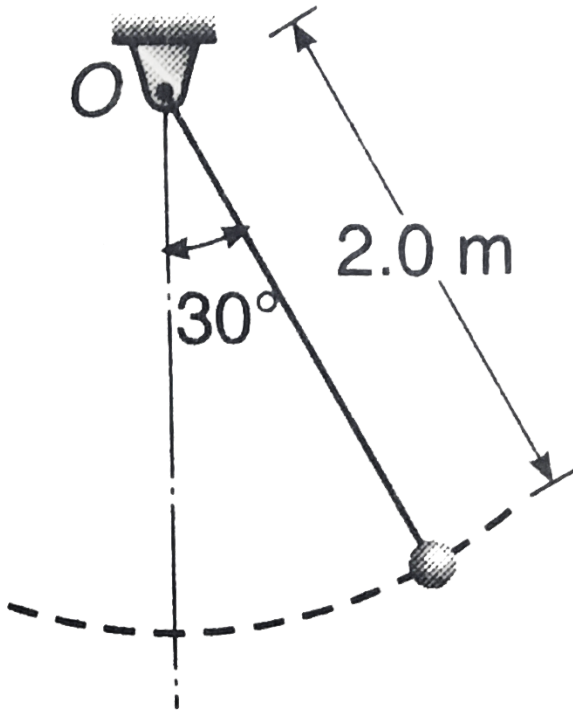

A.  $16.75\text{ms}^{-1}$ ,  $5.66\text{ms}^{-2}$

B.  $5.66\text{ms}^{-1}$ ,  $16.75\text{ms}^{-2}$

C.  $2.88\text{ms}^{-1}$ ,  $16.75\text{ms}^{-2}$

D.  $5.66\text{ms}^{-1}$ ,  $8.34\text{ms}^{-2}$



Answer: A::B

 Watch Video Solution

13. The sphere at  $A$  is given a downward velocity  $v_0$  of magnitude  $5m/s$  and swings in a vertical plane at the end of a rope of length  $l = 2m$  attached to a support at  $O$ . Determine the angle  $\theta$  at which the rope will break, knowing that it can withstand a maximum tension equal to twice the weight of the sphere.

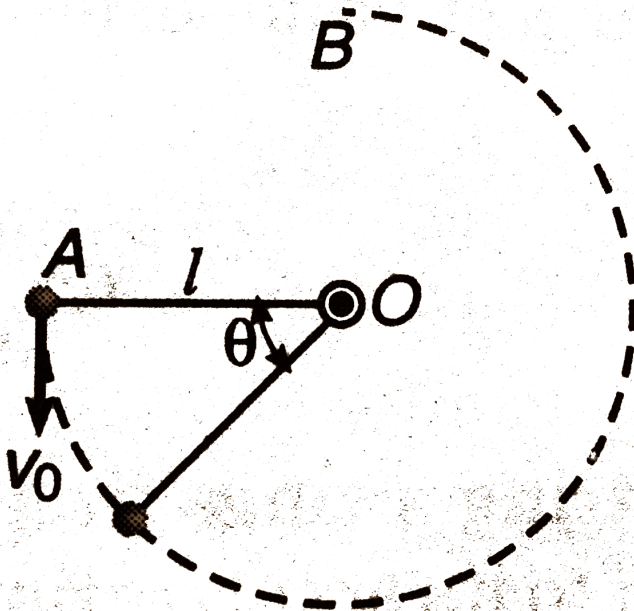

Level 2 Single Correct

1. A collar  $B$  of mass  $2\text{ kg}$  is constrained to move along horizontal smooth and fixed circular track of radius  $5\text{ m}$  and having spring constant  $200\text{ Nm}^{-1}$  is undeformed when the collar is at  $A$ . If the collar starts from rest at  $B$  the normal reaction exerted by the track on the collar when it passes through  $A$  is

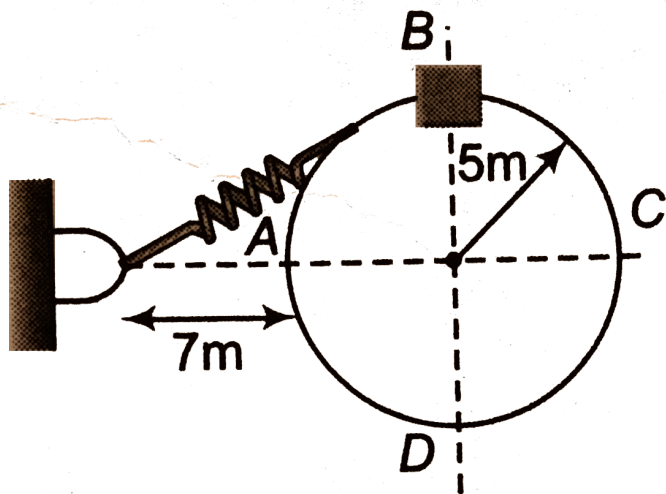

A.  $360\text{ N}$

B.  $720\text{ N}$

C.  $1440N$

D.  $2880N$

**Answer: C**



**Watch Video Solution**

2. A particle is at rest with respect to the wall of an inverted cone rotating with uniform angular velocity  $\omega$  about its central axis. The displacement

of particle along the surface up or down, the equilibrium of particle is

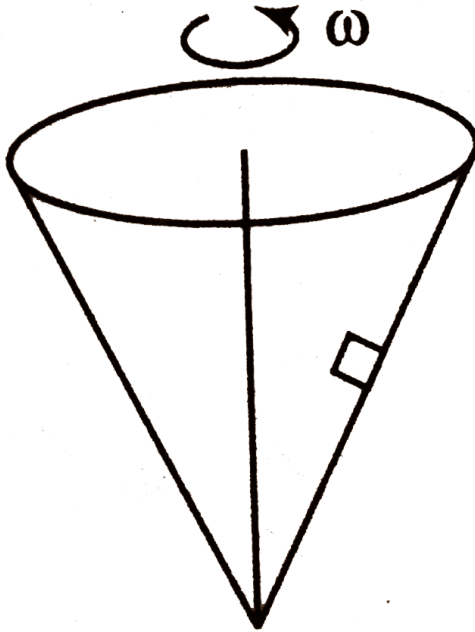

- A. (a)stable
- B. (b)unstable
- C. (c)neutral
- D. (d)None of these

**Answer: B**



**Watch Video Solution**

3. A rough horizontal plate rotates with angular velocity  $\omega$  about a fixed vertical axis. A particle of mass  $m$  lies on the plate at a distance  $\frac{5a}{4}$  from this axis. The coefficient of friction between the plate and the particle is  $\frac{1}{3}$ . The largest value of  $\omega^2$  for which the particle will continue to be at rest on the revolving plate is

A. (a)  $\frac{g}{3a}$

B. (b)  $\frac{4g}{5a}$

C. (c)  $\frac{4g}{9a}$

D. (d)  $\frac{4g}{15a}$

**Answer: D**



**Watch Video Solution**

4. A ball attached to one end of a string swings in a vertical plane such that its acceleration at point  $A$  (extreme position) is equal to its

acceleration at point  $B$  (mean position), The angle  $\theta$  is

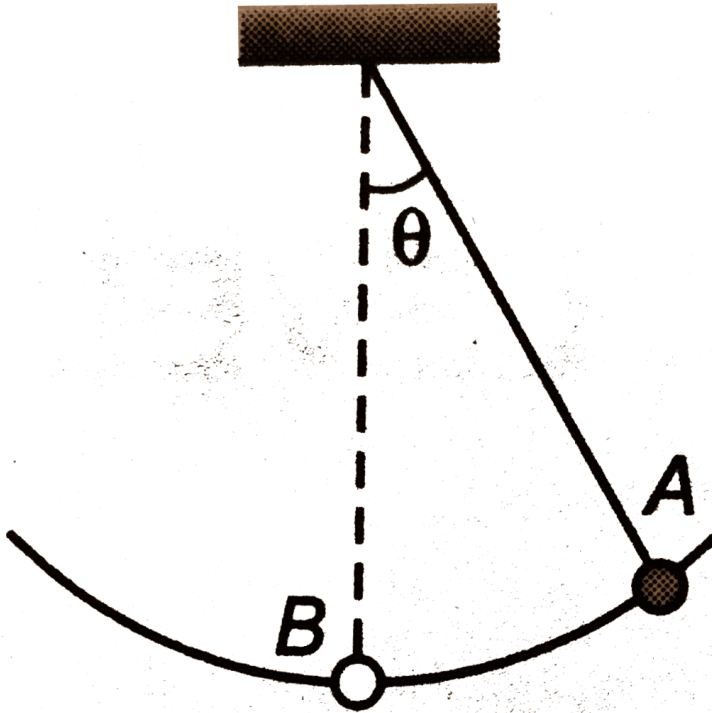

A. (a)  $\cos^{-1}\left(\frac{2}{5}\right)$

B. (b)  $\cos^{-1}\left(\frac{4}{5}\right)$

C. (c)  $\cos^{-1}\left(\frac{3}{5}\right)$

D. (d) None of these

**Answer: C**



**Watch Video Solution**

5. A skier plans to ski a smooth fixed hemisphere of radius  $R$ . He starts from rest from a curve smooth surface of height  $\left(\frac{R}{4}\right)$ . The angle  $\theta$  at which he leaves the hemisphere is

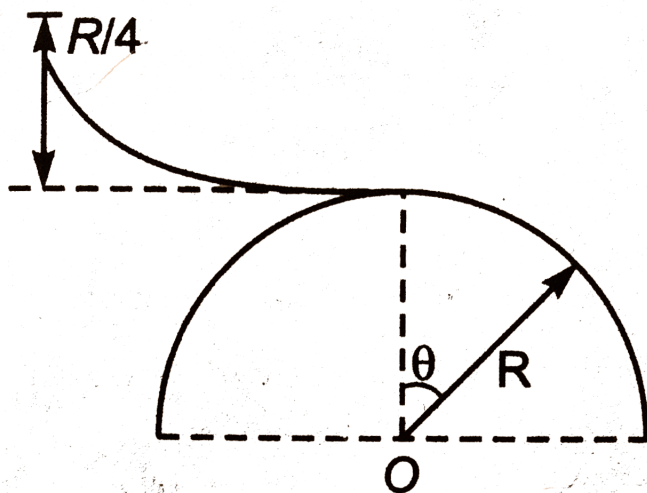

- A.  $\cos^{-1}\left(\frac{2}{3}\right)$
- B.  $\frac{\cos^{-1}(5)}{\sqrt{3}}$
- C.  $\cos^{-1}\left(\frac{5}{6}\right)$
- D.  $\cos^{-1}\left[\frac{5}{2\sqrt{3}}\right]$

Answer: C

 Watch Video Solution

6. A section of fixed smooth circular track of radius  $R$  in vertical plane is shown in the figure. A block is released from position  $A$  and leaves the track at  $B$ . The radius of curvature of its trajectory just after it leaves the track is ?

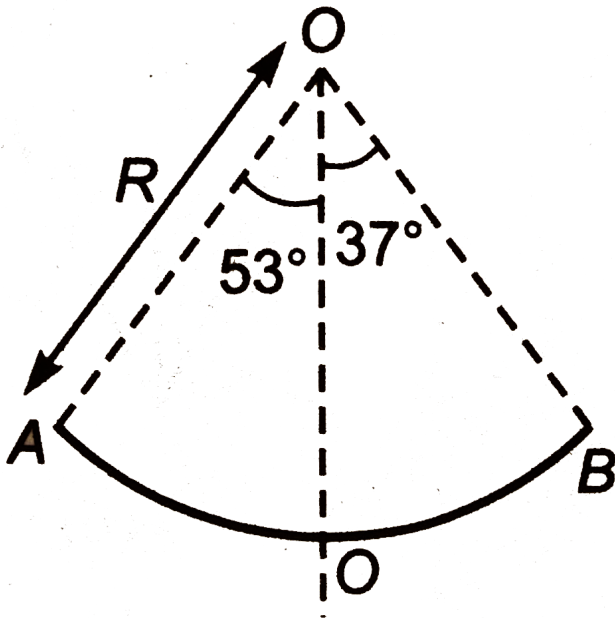

A. (a)  $R$



B. (b)  $\frac{R}{4}$

C. (c)  $\frac{R}{2}$

D. (d)  $\frac{R}{2}$

**Answer: C**



**Watch Video Solution**

7. A particle is projected with velocity  $u$  horizontally from the top of a smooth sphere of radius  $a$  so that it slides down the outside of the sphere. If the particle leaves the sphere when it has fallen a height  $\frac{a}{4}$ , the value of  $u$  is

A.  $\sqrt{ag}$

B.  $\frac{\sqrt{ag}}{4}$

C.  $\frac{\sqrt{ag}}{2}$

D.  $\frac{\sqrt{ag}}{3}$

**Answer: C**



**Watch Video Solution**

8. A particle of mass  $m$  describes a circle of radius  $r$  . The centripetal acceleration of the particle is  $\frac{4}{r^2}$  . What will be the momentum of the particle ?

A.  $2\frac{m}{r}$

B.  $2\frac{m}{\sqrt{r}}$

C.  $4\frac{m}{\sqrt{r}}$

D. None of these

**Answer: B**



**Watch Video Solution**

9. A  $10\text{kg}$  ball attached at the end of a rigid massless rod of length  $1\text{m}$  rotates at constant speed in a horizontal circle of radius  $0.5\text{m}$  and period of  $1.58\text{s}$ , as shown in the figure. The force exerted by the rod on the ball is ( $g = 10\text{ms}^{-2}$ )

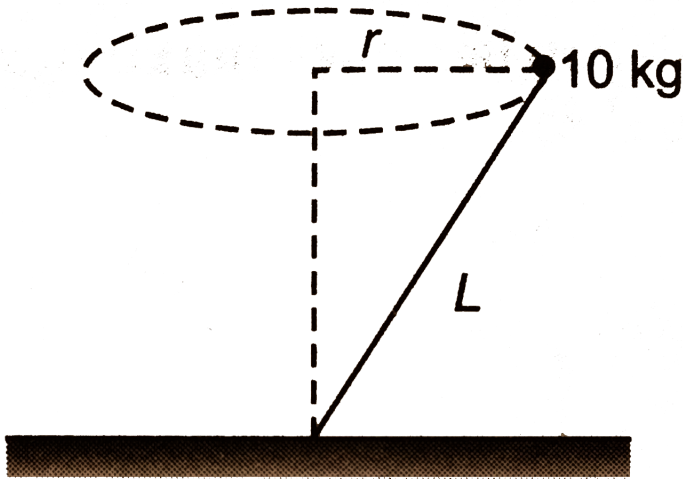

- A.  $158\text{N}$
- B.  $128\text{N}$
- C.  $110\text{N}$
- D.  $98\text{N}$

**Answer: B**

10. A disc is rotating in a room. A boy standing near the rim of the disc of radius  $R$  finds the water droplet falling from the ceiling is always falling on his head. As one drop hits his head, other one starts from the ceiling. If height of the roof above his head is  $H$ , then angular velocity of the disc is

A.  $\pi \sqrt{\frac{2gR}{H^2}}$

B.  $\pi \sqrt{\frac{2gH}{R^2}}$

C.  $\pi \sqrt{\frac{2g}{H}}$

D. None of these

**Answer: C**

11. In a clock, what is the time period of meeting of the minute hand and the second hand ?

A.  $59s$

B.  $\frac{60}{59}s$

C.  $\frac{59}{60}s$

D.  $\frac{3600}{59}s$

**Answer: D**



[Watch Video Solution](#)

12. A particle of mass  $m$  starts to slide down from the top of the fixed smooth sphere. What is the tangential acceleration when it break off the sphere ?

A.  $\frac{2g}{3}$

B.  $\frac{\sqrt{5}g}{3}$

C.  $g$

D.  $\frac{g}{3}$

**Answer: B**



[Watch Video Solution](#)

13. A particle is given an initial speed  $u$  inside a smooth spherical shell of radius  $R$  so that it is just able to complete the circle. Acceleration of the particle, when its velocity is vertical, is

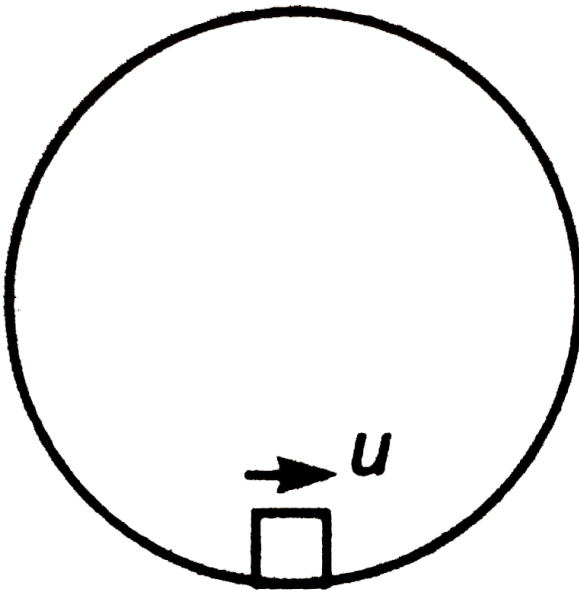

A.  $g\sqrt{10}$

B.  $g$

C.  $g\sqrt{2}$

D.  $g\sqrt{6}$

**Answer: A**



**Watch Video Solution**

**14.** An insect of mass  $m = 3kg$  is inside a vertical drum of radius  $2m$  that is rotating with an angular velocity of  $5rad\,s^{-1}$ . The insect doesn't fall

off. Then, the minimum coefficient of friction required is

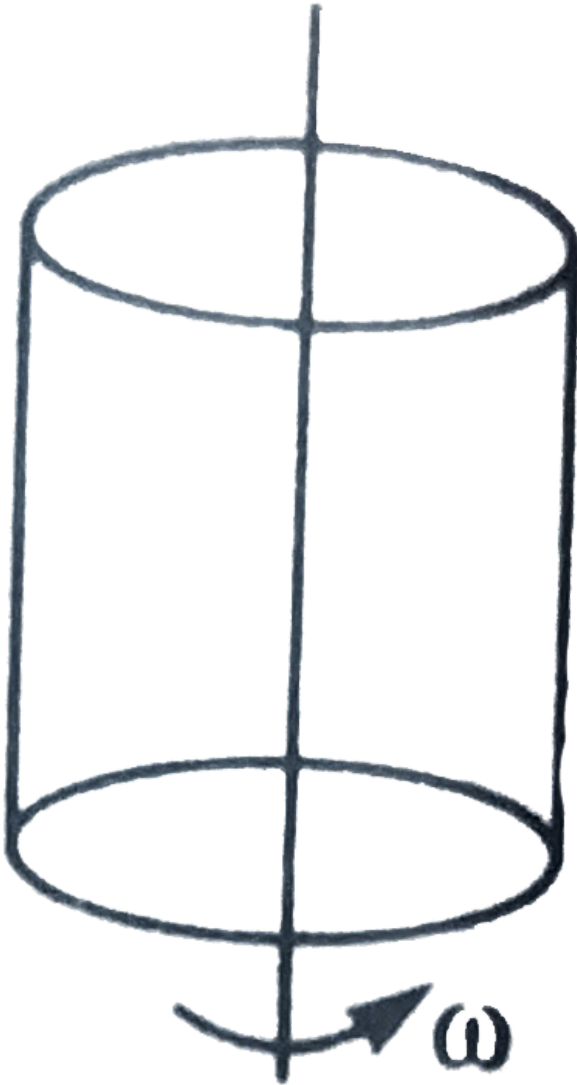

A. 0.5



B. 0.4

C. 0.2

D. None of these

**Answer: C**



**Watch Video Solution**

15. A simple pendulum is released from rest with the string in horizontal position. The vertical component of the velocity of the bob becomes maximum, when the string makes an angle  $\theta$  with the vertical. The angle  $\theta$  is equal to

A. (a)  $\frac{\pi}{4}$

B. (b)  $\cos^{-1}\left(\frac{1}{\sqrt{3}}\right)$

C. (c)  $\sin^{-1}\left(\frac{1}{\sqrt{3}}\right)$

D. (d)  $\frac{\pi}{3}$

**Answer: B**



**Watch Video Solution**

**16.** A particle is moving in a circle of radius  $R$  in such a way that at any instant the normal and tangential component of the acceleration are equal. If its speed at  $t = 0$  is  $u_0$  the time taken to complete the first revolution is

A.  $\frac{R}{v_0}$

B.  $\frac{R}{v_0} e^{-2\pi}$

C.  $\frac{R}{v_0} (1 - e^{-2\pi})$

D.  $\frac{R}{v_0} (1 + e^{-2\pi})$

**Answer: C**



**Watch Video Solution**

17. A particle is moving in a circular path in the vertical plane. It is attached at one end of a string of length  $l$  whose other end is fixed. The velocity at lowest point is  $u$ . The tension in the string  $T$  and acceleration of the particle is  $a$  at any position. Then  $T \cdot a$  is zero at highest point if

A.  $u > \sqrt{5gl}$

B.  $u = \sqrt{5gl}$

C. Both (a) and (b) are correct

D. Both (a) and (b) are wrong

**Answer: B**



**Watch Video Solution**

18. A particle is moving in a circular path in the vertical plane. It is attached at one end of a string of length  $l$  whose other end is fixed. The velocity at lowest point is  $u$ . The tension in the string is  $T$  and

acceleration of the particle is  $a$  at any position then 'T.  $a$ ' is positive at the lowest point for

A.  $u = \sqrt{2gl}$

B.  $u = \sqrt{5gl}$

C.  $u = \sqrt{7gl}$

D. any value of  $u$

**Answer: D**



[Watch Video Solution](#)

## Level 2 More Than One Correct

1. A ball tied to the end of the string swings in a vertical plane in a vertical circle under the influence of gravity.

A. When the string makes an angle  $90^\circ$  with the vertical, the tangential acceleration is zero and radial acceleration is somewhere

between minimum and maximum

- B. When the string makes an angle  $90^\circ$  with the vertical, the tangential acceleration is maximum and radial acceleration is somewhere between maximum and minimum
- C. At no place in circular motion, tangential acceleration is equal to radial acceleration
- D. When radial acceleration has its maximum value, the tangential acceleration is zero

**Answer: B::D**



**Watch Video Solution**

2. A small spherical ball is suspended through a string of length  $l$ . The whole arrangement is placed in a vehicle which is moving with velocity  $v$ . Now, suddenly the vehicle stops and ball starts moving along a circular

path. If tension in the string at the highest point is twice the weight of the ball then (assume that the ball completes the vertical circle)

A.  $v = \sqrt{5gl}$

B.  $v = \sqrt{7gl}$

C. velocity of the ball at highest point is  $\sqrt{gl}$

D. velocity of the ball at highest point is  $\sqrt{3gl}$

**Answer: B::D**



**Watch Video Solution**

3. A particle is describing circular motion in a horizontal plane in contact with the smooth surface of a fixed rigid circular cone with its axis vertical and vertex down. The height of the plane of motion above the vertex is  $h$  and the semi-vertical angle of the cone is  $\alpha$ . The period of revolution of

the particle

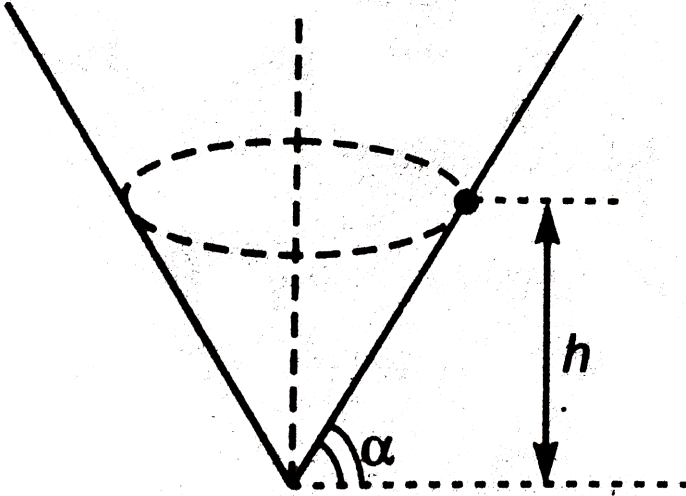

- A. increases as  $h$  increases
- B. decreases as  $h$  decreases
- C. increases as  $\alpha$  increases
- D. decreases as  $\alpha$  decreases

Answer: A::D



Watch Video Solution

4. In circular motion of a particle,

- A. particle cannot have uniform motion
- B. particle cannot have uniformly acceleration motion
- C. particle cannot have net acceleration equal to zero
- D. particle cannot have any force in tangential direction

**Answer: A::B::C**



[Watch Video Solution](#)

5. A smooth cone is rotated with an angular velocity  $\omega$  as shown. A block  $A$  is placed at height  $h$ . Block has no motion relative to cone. Choose the



correct options, when  $\omega$  is increased.

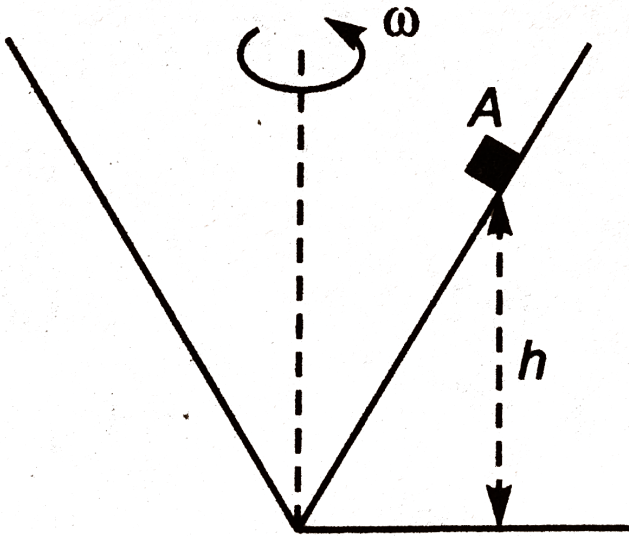

- A. net force acting on block will increase
- B. normal reaction acting on block will increase
- C.  $h$  will increase
- D. normal reaction will remain unchanged

Answer: D



Watch Video Solution

1. A ball with mass  $m$  is attached to the end of a rod of mass  $M$  and length  $l$ . The other end of the rod is pivoted so that the ball can move in a vertical circle. The rod is held in the horizontal position as shown in figure and then given just enough a downward push so that the ball swings down and just reaches the vertical upward position having zero speed there. Now answer the following questions.

The change in potential energy of the system (ball+rod) is

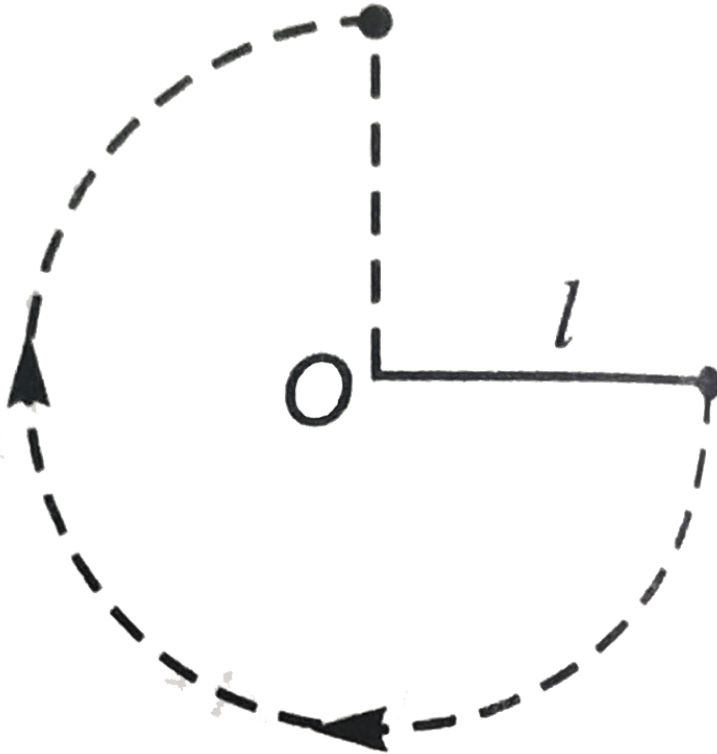

A.  $mgl$

B.  $(M + m)gl$

C.  $\left(\frac{M}{2} + m\right)gl$

D.  $\frac{(M + m)}{2}gl$

**Answer: C**



**Watch Video Solution**

2. A ball with mass  $m$  is attached to the end of a rod of mass  $M$  and length  $l$ . The other end of the rod is pivoted so that the ball can move in a vertical circle. The rod is held in the horizontal position as shown in figure and then given just enough a downward push so that the ball swings down and just reaches the vertical upward position having zero speed there. Now answer the following questions.

The initial speed given to the ball is

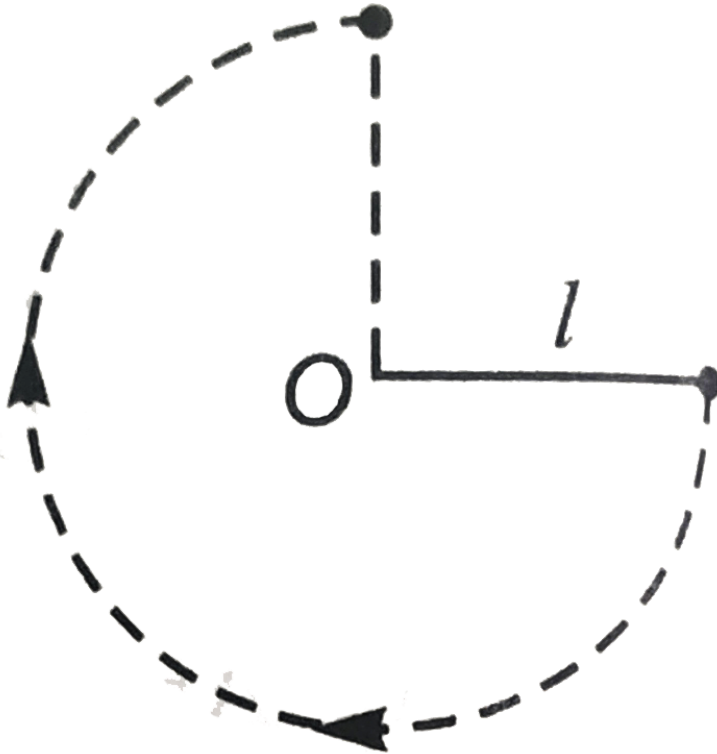

A.  $\sqrt{\frac{Mgl + 2mgl}{m}}$

B.  $\sqrt{2gl}$

C.  $\sqrt{\frac{2Mgl + mgl}{m}}$

D. None of these

**Answer: D**



**Watch Video Solution**

3. A small particle of mass  $m$  attached with a light inextensible thread of length  $L$  is moving in a vertical circle. In the given case particle is moving in complete vertical circle and ratio of its maximum to minimum velocity is 2:1 .

Minimum velocity of the particle is



A. (a)  $4\sqrt{\frac{gL}{3}}$

B. (b)  $2\sqrt{\frac{gL}{3}}$

C. (c)  $\sqrt{\frac{gL}{3}}$

D. (d)  $3\sqrt{\frac{gL}{3}}$

**Answer: B**

4. A small particle of mass  $m$  attached with a light inextensible thread of length  $L$  is moving in a vertical circle. In the given case particle is moving in complete vertical circle and ratio of its maximum to minimum velocity is 2 : 1 .

Kinetic energy of the particle at the lower most position is





A. (a)  $\frac{4mgL}{3}$

B. (b)  $2mgL$

C. (c)  $\frac{8mgL}{3}$

D. (d)  $\frac{2mgL}{3}$

**Answer: C**



**Watch Video Solution**

5. A small particle of mass  $m$  attached with a light inextensible thread of length  $L$  is moving in a vertical circle. In the given case particle is moving in complete vertical circle and ratio of its maximum to minimum velocity is 2:1 .

Velocity of the particle when it is moving vertically downward is

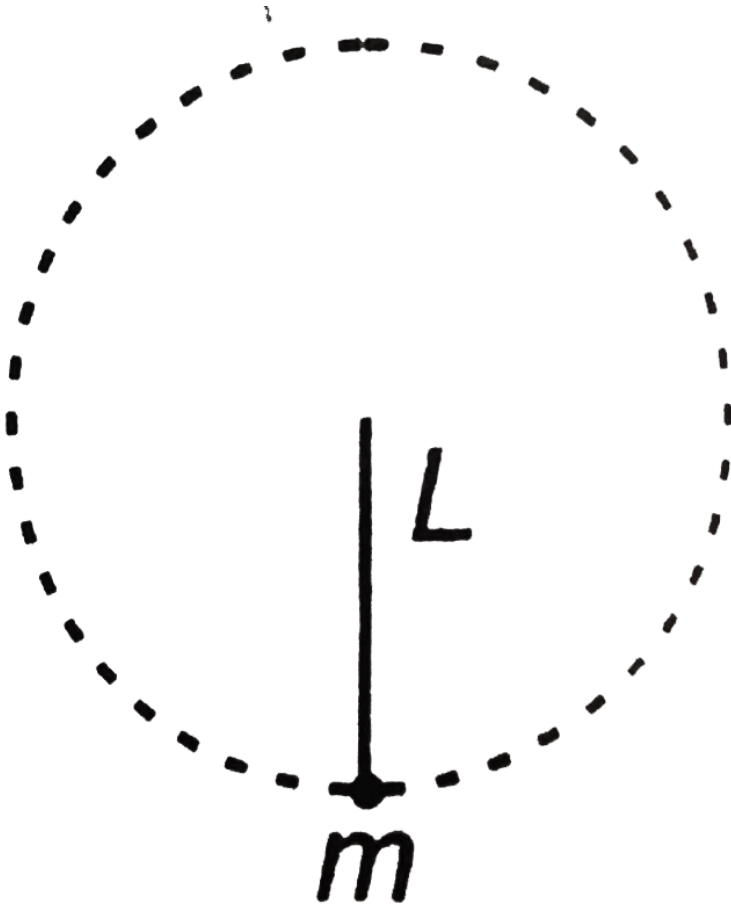

A. (a)  $\sqrt{\frac{10gL}{3}}$

B. (b)  $2\sqrt{\frac{gL}{3}}$

C. (c)  $\sqrt{\frac{8gL}{3}}$

D. (d)  $\sqrt{\frac{13gL}{3}}$

**Answer: A**



**Watch Video Solution**

## Level 2 Subjective

1. Bob  $B$  of the pendulum  $AB$  is given an initial velocity  $\sqrt{3Lg}$  in horizontal direction. Find the maximum height of the bob from the starting point,

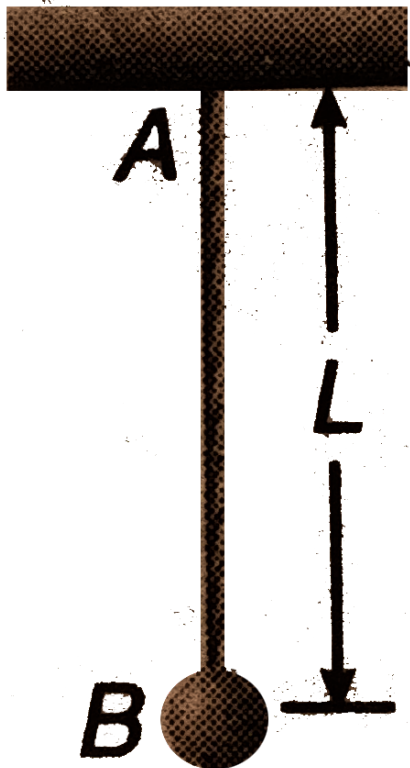

(a) if  $AB$  is a massless rod,

(b) if  $AB$  is a massless string.



[Watch Video Solution](#)

2. A small sphere  $B$  of mass  $m$  is released from rest in the position shown and swings freely in a vertical plane, first about  $O$  and then about the peg  $A$  after the cord comes in contact with the peg. Determine the tension in

the cord

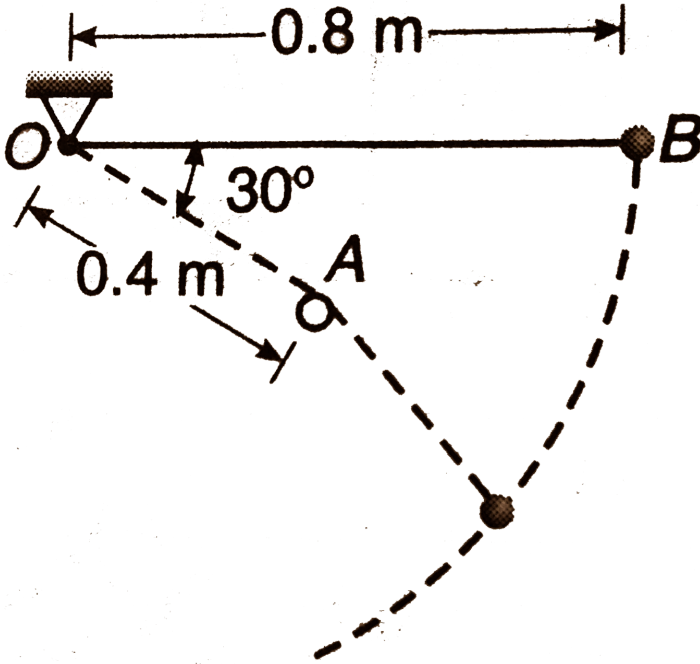

(a) just before the sphere comes in contact with the peg.

(b) just after it comes in contact with the peg.



[Watch Video Solution](#)

3. A particle of mass  $m$  is suspended by a string of length  $l$  from a fixed rigid support. A sufficient horizontal velocity  $= \sqrt{3gl}$  is imparted to it

suddenly. Calculate the angle made by the string with the vertical when the acceleration of the particle is inclined to the string by  $45^\circ$ .

 [Watch Video Solution](#)

4. A turn of radius 20 m is banked for the vehicles going at a speed of 36km/h. If the coefficient of static friction between the road and the tyre is 0.4, what are the possible speeds of a vehicle so that it neither slips down nor skids up?

 [Watch Video Solution](#)

5. What is the radius of curvature of the parabola traced out by the projectile in which a particle is projected by a speed  $u$  at an angle ' $\theta$ ' with the horizontal, at a point where the particle velocity makes an angle  $\frac{\theta}{2}$  with the horizontal?

 [Watch Video Solution](#)

6. A particle is projected with velocity  $20\sqrt{2}m/s$  at  $45^\circ$  with horizontal. After  $1s$ , find tangential and normal acceleration of the particle. Also, find radius of curvature of the trajectory at that point. (Take  $g = 10m/s^2$ )



[Watch Video Solution](#)

7. If the system shown in the figure is rotated in a horizontal circle with angular velocity  $\omega$ . Find ( $g = 10m/s^2$ )

(a) the minimum value of  $\omega$  to start relative motion between the two blocks.

(b) tension in the string connecting  $m_1$  and  $m_2$  when slipping just starts between the blocks

The coefficient of friction between the two masses is  $0.5$  and there is no friction between  $m_2$  and ground. The dimensions of the masses can be

neglected. (Take  $R = 0.5m$ ,  $m_1 = 2Kg$ ,  $m_2 = 1Kg$ )

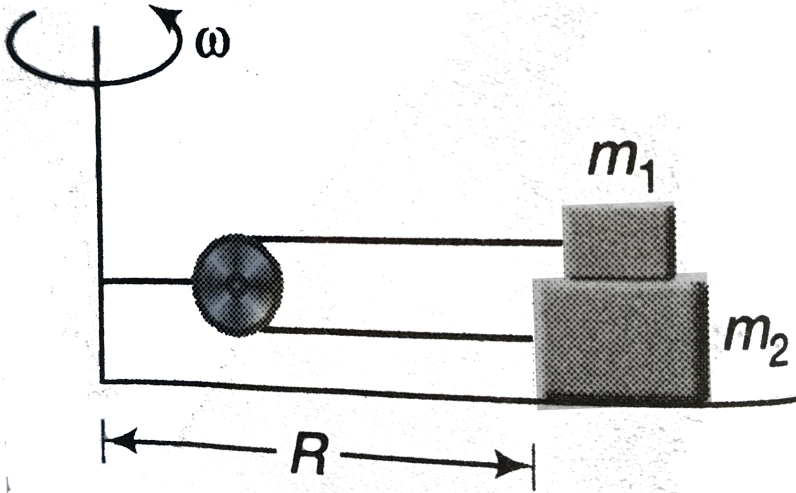

[▶ Watch Video Solution](#)

8. The simple  $2Kg$  pendulum is released from rest in the horizontal position. As it reaches the bottom position, the cord wraps around the smooth fixed pin at  $B$  and continues in the smaller arc in the vertical plane. Calculate the magnitude of the force  $R$  supported by the pin at  $B$



when the pendulum passes the position  $\theta = 30^\circ$ , ( $g = 9.8 \text{ m/s}^2$ )

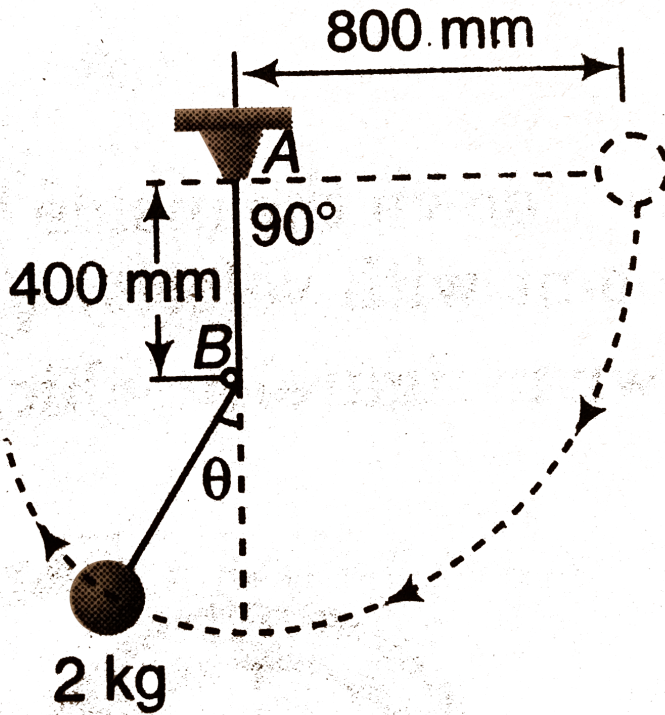

[▶ Watch Video Solution](#)

9. A circular tube of mass  $M$  placed vertically on a horizontal surface as shown in the figure. Two small spheres, each of mass  $m$ , just fit in the tube, are released from the top. If  $\theta$  gives the angle between radius vector of either ball with the vertical, obtain the value of the ratio  $M/m$  if the

tube breaks its contact with ground when  $\theta = 60^\circ$ . Neglect any friction.

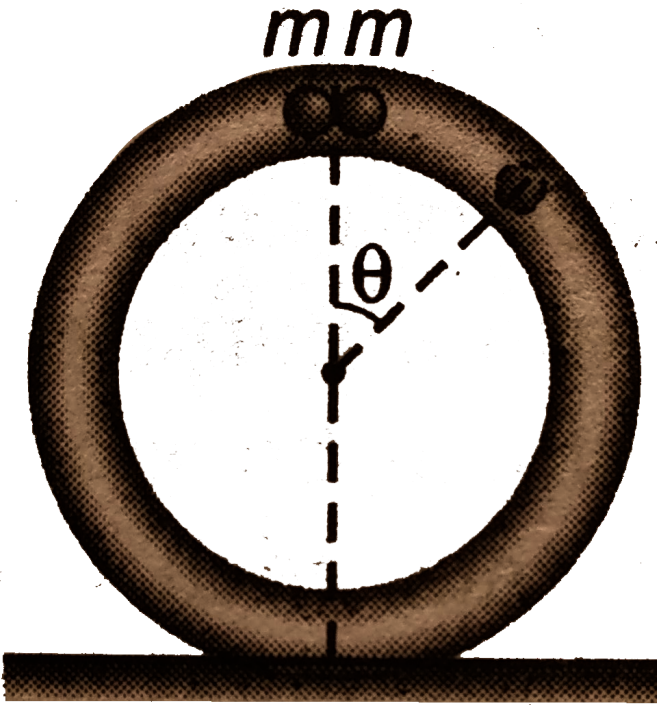

[▶ Watch Video Solution](#)

10. A table with smooth horizontal surface is turning at an angular speed  $\omega$  about its axis. A groove is made on the surface along a radius and a particle is gently placed inside the groove at a distance  $a$  from the centre. Find the speed of the speed of the particle as its distance from the centre becomes  $L$ .

A.  $\omega\sqrt{L^2 - a^2}$

B.  $\omega\sqrt{a^2 - L^2}$

C.  $\omega\sqrt{2L^2 - a^2}$

D.  $\omega\sqrt{L^2}$

**Answer: A::B**



**Watch Video Solution**

**11.** A block of mass  $m$  slides on a frictionless table. It is constrained to move inside a ring of radius  $R$ . At time  $t = 0$ , block is moving along the inside of the ring (i.e. in the tangential direction) with velocity  $v_0$ . The coefficient of friction between the block and the ring is  $\mu$ . Find the speed

of the block at time  $t$ .

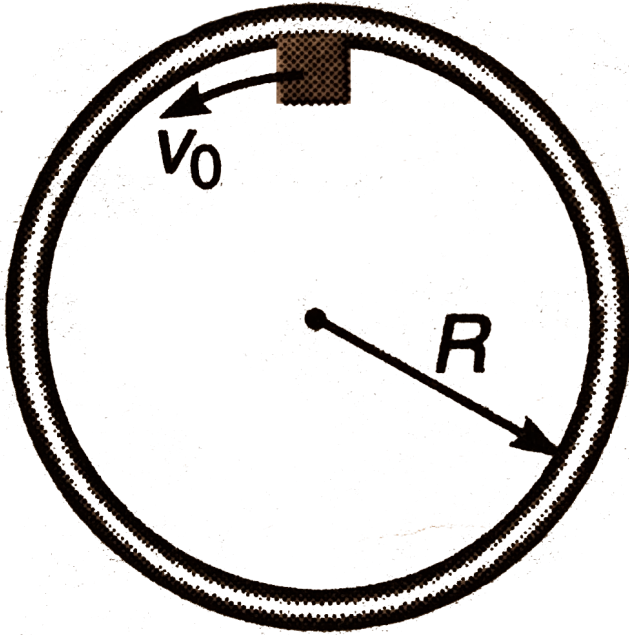

Watch Video Solution

12. A ring of mass  $M$  hangs from a thread and two beads of mass  $m$  slides on it without friction. The beads are released simultaneously from the top of the ring and slides down in opposite sides. Show that the ring

will

start

to

rise,

if

$$m > \frac{3M}{2}$$

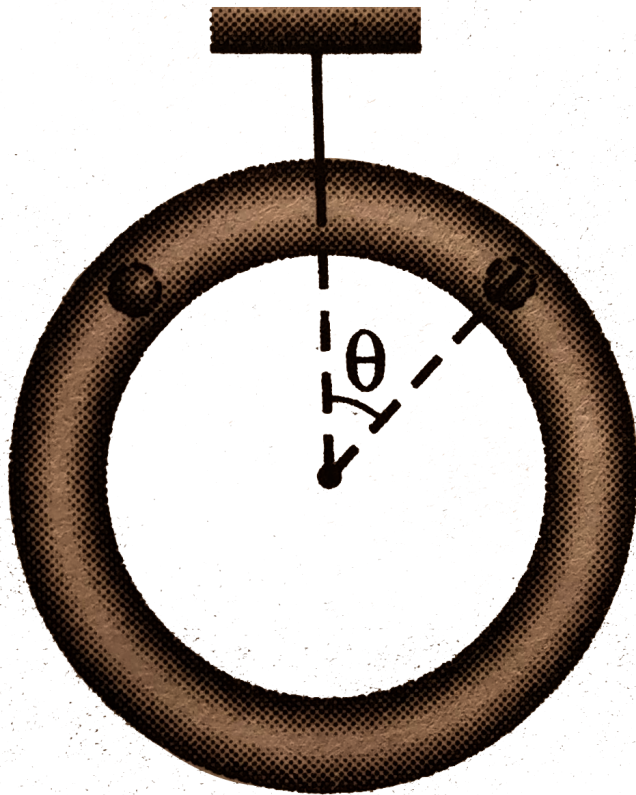

[Watch Video Solution](#)

**13.** A smooth circular tube of radius  $R$  is fixed in a vertical plane. A particle is projected from its lowest point with a velocity just sufficient to carry it to the highest point. Show that the time taken by the particle to reach the

end of the horizontal diameter is  $\left(\frac{\sqrt{R}}{g}\right) \ln(1 + \sqrt{2})$ .

Hint :  $\int \sec \theta \cdot d\theta = \ln(\sec \theta + \tan \theta)$



[Watch Video Solution](#)

## Subjective Questions

1. A particle is given an initial speed  $u$  inside a smooth spherical shell of radius  $R$  so that it is just able to complete the circle. Acceleration of the

particle, when its velocity is vertical, is

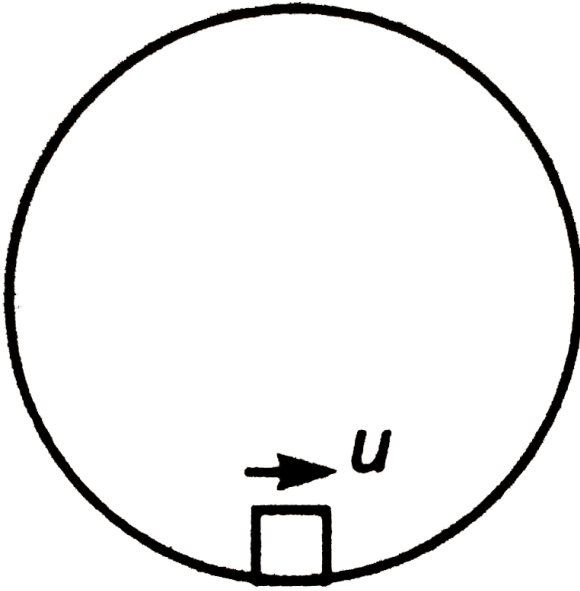

[▶ Watch Video Solution](#)

2. A vertical frictionless semicircular track of radius  $1m$  fixed on the edge of a movable trolley (figure). Initially, the system is at rest and a mass  $m$  is kept at the top of the track. The trolley starts moving to the right with a uniform horizontal acceleration  $a = 2g/9$ . The mass slides down the track, eventually losing contact with it and dropping to the floor  $1.3m$  below the trolley. This  $1.3m$  is from the point where mass loses contact.

$$(g = 10\text{m/s}^2)$$

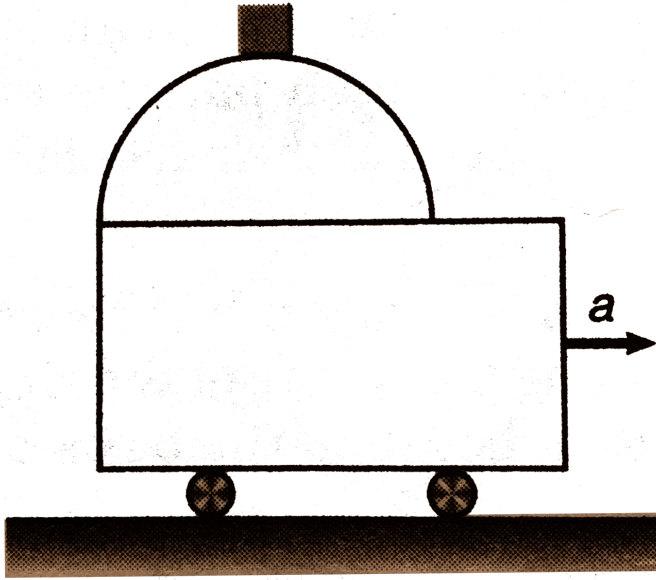

- (a) Calculate the angle  $\theta$  at which it loses contact with the trolley and
- (b) the time taken by the mass to drop on the floor, after losing contact.

[▶ Watch Video Solution](#)

JEE Main

1. The magnitude of displacement of a particle moving in a circle of radius  $a$  with constant angular speed  $\omega$  varies with time  $t$  is



A.  $2a \sin \omega t$

B.  $2a \sin \frac{\omega t}{2}$

C.  $2a \cos \omega t$

D.  $2a \cos \frac{\omega t}{2}$

**Answer: B**



**Watch Video Solution**

2. A particle moves in  $x - y$  plane according to the law  $x = 4 \sin 6t$  and  $y = 4(1 - \cos 6t)$ . The distance traversed by the particle in 4 second is ( $x$  &  $y$  are in meters)

A. 96 m

B. 48 m

C. 24 m

D. 108 m

Answer: A

 Watch Video Solution

3. A  $x$  and  $y$  co-ordinates of a particle are  $x = A \sin(\omega t)$  and  $y = A \sin(\omega t + \pi/2)$ . Then, the motion of the particle is

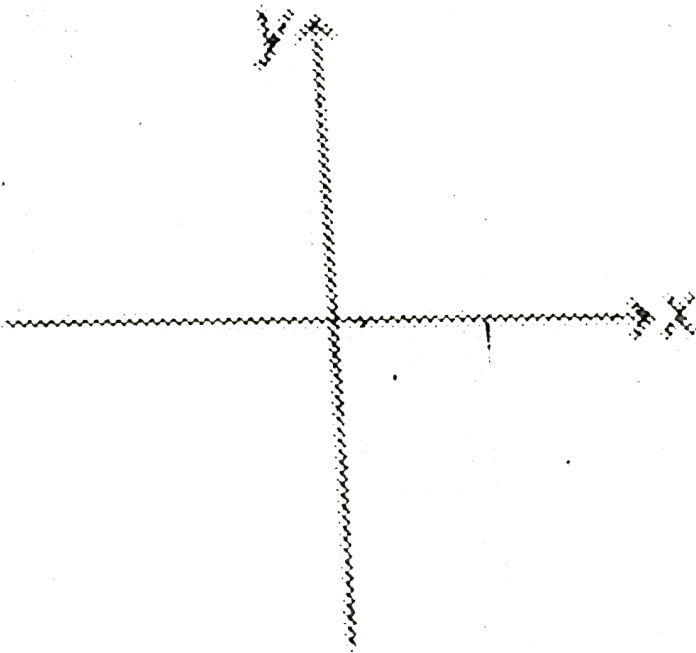

A. circular anticlockwise

B. circular clockwise

C. elliptical clockwise

D. rectilinear

**Answer: B**



[Watch Video Solution](#)

4. Position vector of a particle moving in  $x - y$  plane at time  $t$  is

$r = a(1 - \cos \omega t)\hat{i} + a \sin \omega t\hat{j}$ . The path of the particle is

A. a circle of radius  $a$  and centre and  $(a,0)$

B. a circle of radius  $a$  and centre at  $(0,0)$

C. an ellipse

D. Neither a circle nor an ellipse

**Answer: A**



[Watch Video Solution](#)

5. Starting from rest, a particle rotates in a circle of radius  $R = \sqrt{2}m$  with an angular acceleration  $= \frac{\pi}{4} \text{ rad/s}^2$ . The magnitude of average velocity of the particle over the time it rotates quarter circle is:

A. 1.5 m/s

B. 2 m/s

C. 1 m/s

D. 1.25 m/s

**Answer: C**



[Watch Video Solution](#)

6. A bob hangs from a rigid support by an inextensible string of length  $l$ . If it is displaced through a distance  $l$  (from the lowest position) keeping the string straight and then released. The speed of the bob at the lowest

position is

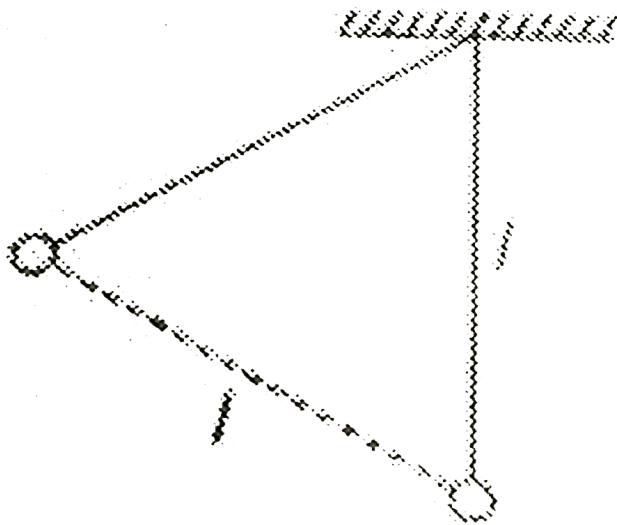

- A.  $\sqrt{gl}$
- B.  $\sqrt{3gl}$
- C.  $\sqrt{2gl}$
- D.  $\sqrt{1.5gl}$

**Answer: A**



**Watch Video Solution**

7. A particle suspended from a fixed point, by a light inextensible thread of length  $L$  is projected horizontally from its lowest position with velocity  $7gL$ . The thread will slack after swinging through an angle  $\theta$ , such that

A.  $127^\circ$

B.  $135^\circ$

C.  $120^\circ$

D.  $150^\circ$

**Answer: C**



[Watch Video Solution](#)

8. With what minimum speed  $v$  must a small ball should be pushed inside a smooth vertical tube from a height  $h$  so that it may reach the top of the

tube? Radius of the tube is  $R$ .

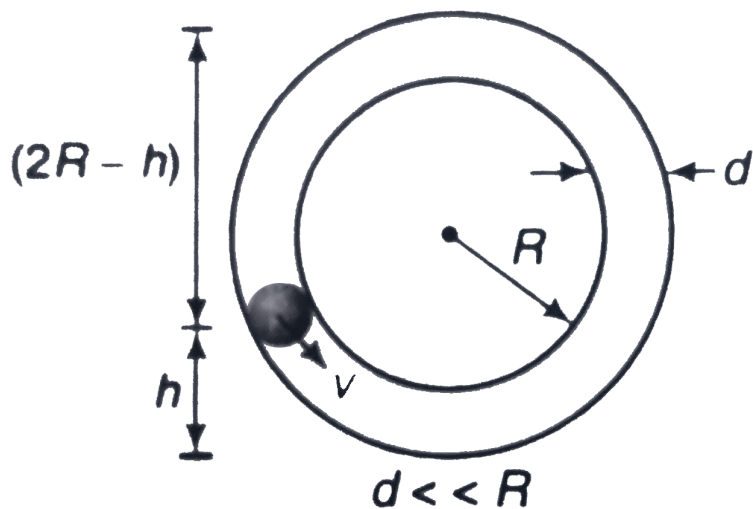

A.  $\sqrt{2g(h + 2R)}$

B.  $\frac{5}{2}R$

C.  $\sqrt{g(5R - 2h)}$

D.  $\sqrt{2g(2R - h)}$

**Answer: D**



**Watch Video Solution**

9. The second's hand of a watch has length 6 cm. Speed of end point and magnitude of difference of velocities at two perpendicular positions will be

- A.  $2\pi$  and zero
- B.  $2\sqrt{2}\pi$  and  $2\pi\text{mm/s}$
- C.  $2\sqrt{2}\pi$  and  $2\pi\text{mm/s}$
- D.  $2\pi$  and  $2\sqrt{2}\pi\text{mm/s}$

**Answer: D**



[Watch Video Solution](#)

10. A pendulum bob is swinging in a vertical plane such that its angular amplitude is less than  $90^\circ$ . At its highest point, the string is cut. Which trajectory is possible for the bob afterwards ?

A. 



(b)

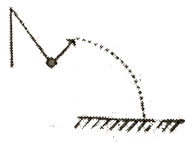

B.

(c)

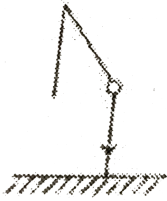

C.

(d)

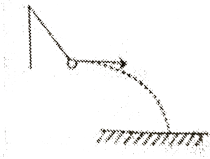

D.

**Answer: C**



**Watch Video Solution**

**11.** A hollow vertical cylinder of radius  $R$  is rotated with angular velocity  $\omega$  about an axis through its centre. What is the minimum coefficient of static friction between block  $M$  and cylinder wall necessary to keep the

block suspended on the inside of the cylinder ?

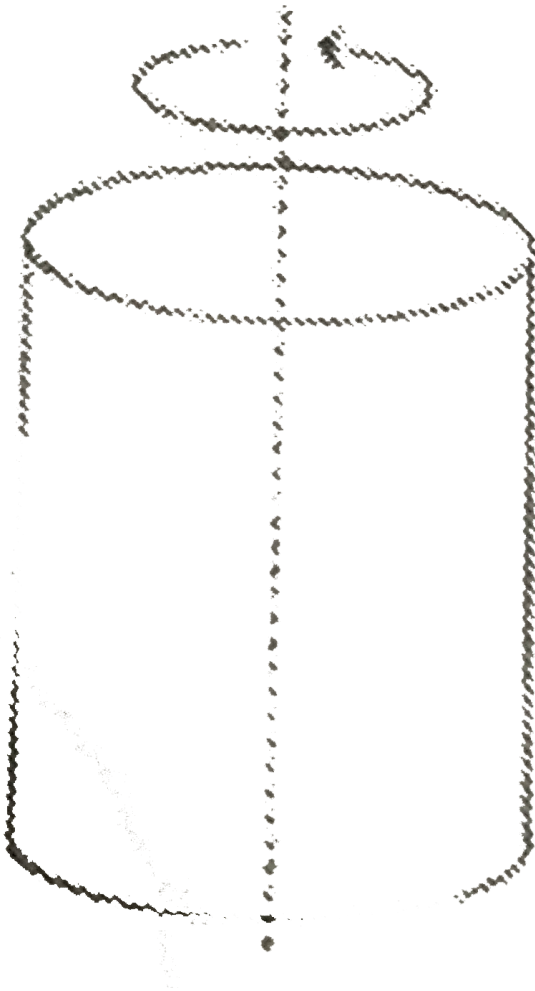

A.  $\mu = \frac{gR}{\omega^2}$

B.  $\mu = \frac{\omega^2 g}{R}$

C.  $\mu = \frac{\omega^2 R}{g}$

D.  $\mu = \frac{g}{\omega^2 R}$

**Answer: D**



**Watch Video Solution**

12. A bob of mass  $m$  attached to an inextensible string of length  $l$  is suspended from a verticle support. The bob rotates in a horizontal circle with an angular speed  $\omega \text{ rad/s}$  about the verticle. About the point of suspension.

A.  $l / \cos \theta$

B.  $l \sin \theta$

C.  $l / \sin \theta$

D.  $l \cos \theta$

**Answer: D**



**Watch Video Solution**

13. A particle of mass  $m$  attached to a string of length  $l$  is descending circular motion on a smooth plane inclined at an angle  $\alpha$  with the horizontal. For the particle to reach the highest point its velocity at the lowest point should exceed.

A.  $\sqrt{5gl}$

B.  $\sqrt{5gl(\cos \alpha + 1)}$

C.  $\sqrt{5gl / \tan \alpha}$

D.  $\sqrt{5gl \sin \alpha}$

**Answer: D**



**Watch Video Solution**

14. A pendulum of mass 1 kg and length = 1m is released from rest at angle =  $60^\circ$ . The power delivered by all the forces acting on the bob at angle =  $30^\circ$  will be: ( $g = 10 \text{ m/s}^2$ )

A. 13.4 W

B. 20.4 W

C. 24.6 W

D. zero

**Answer: A**



**Watch Video Solution**

15. (a) A ball, suspended by a thread, swings in a vertical plane so that its acceleration in the extreme and the lowest positions are equal. The angle  $\theta$  of thread deflection in the extreme position will be

( b) The kinetic energy of a particle moving in a circle of radius R depends on the distance covered as  $T = as^2$ , where 'a' is a constant. Find the force acting on the particle as a function of s.

A.  $\tan^{-1}(2)$

B.  $\tan^{-1}(\sqrt{2})$

C.  $\tan^{-1}\left(\frac{1}{2}\right)$

D.  $2 \tan^{-1}\left(\frac{1}{2}\right)$

**Answer: D**

 [Watch Video Solution](#)

16. A simple pendulum consisting of a mass  $M$  attached to a string of length  $L$  is released from rest at an angle  $\alpha$ . A pin is located at a distance  $l$  below the pivot point. When the pendulum swings down, the string hits the pin as shown in figure. The maximum angle  $\theta$  which the string makes with the vertical after hitting the pin is

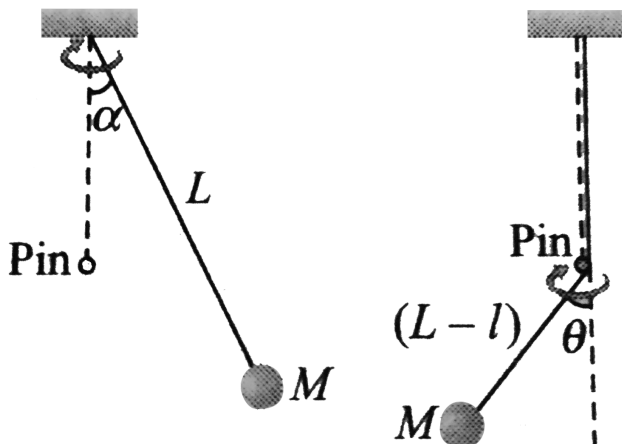

A.  $\cos^{-1} \left[ \frac{L \cos \alpha + l}{L + l} \right]$

B.  $\cos^{-1} \left[ \frac{L \cos \alpha + l}{L - l} \right]$

C.  $\cos^{-1} \left[ \frac{L \cos \alpha - l}{L - l} \right]$

D.  $\cos^{-1} \left[ \frac{L \cos \alpha - l}{L + l} \right]$

**Answer: C**



**Watch Video Solution**

17. A particle moves along a circle of radius  $(20/\pi)m$  with constant tangential acceleration. If the velocity of the particle is  $80m/s$  at the end of the second revolution after motion has begun the tangential acceleration is .

A.  $160\pi m / s^2$

B.  $40\pi m / s^2$

C.  $80m / s^2$

D.  $640\pi m / s^2$

**Answer: C**



**Watch Video Solution**

**18.** The velocity and acceleration vectors of a particle undergoing circular motion are  $v = 2\hat{i}m/s$  and  $a = 2\hat{i} + 4\hat{j}m/s^2$  respectively at some instant of time. The radius of the circle is

A. 1 m

B. 2 m

C. 3 m

D. 4 m

**Answer: A**



**Watch Video Solution**



19. A particle mass  $m$  begins to slide down a fixed smooth sphere from the top of its vertical diameter. Calculate its tangential acceleration, radial acceleration and total acceleration when it breaks off.

A.  $\frac{2g}{3}$

B.  $\frac{\sqrt{5}g}{3}$

C.  $g$

D.  $\frac{g}{3}$

**Answer: B**



[Watch Video Solution](#)

20. A car is moving in a circular horizontal track of radius 10 m with a constant speed of  $10\text{ms}^{-1}$ . A plumb bob is suspended from the roof of the car by a light rigid rod of length 1 m. The angle made by the rod with track is

A. zero

B.  $30^\circ$

C.  $45^\circ$

D.  $60^\circ$

Answer: C

 Watch Video Solution

21. Two identical balls 1 and 2 are tied to two strings as shown in figure. They are rotated about point O. Ball 1 is observed from ball 2, centrifugal force on ball 1 is  $F_1$ . Similarly, ball 2 is observed from ball 1 and centrifugal force on ball 2 is  $F_2$ , then



A.  $|F_1| = |F_2| = 0$

B.  $|F_1| > |F_2|$

C.  $|F_1| = |F_2| \neq 0$

D.  $F_1$  and  $F_2$  are antiparallel

**Answer: B**



**Watch Video Solution**

22. A particle starts moving from rest at  $t = 0$  with a tangential acceleration of constant magnitude of  $\pi m / s^2$  along a circle of radius 6 m. The value of average acceleration, average velocity and average speed during the first  $2\sqrt{3}$  s of motion, are respectively :

A.  $3\sqrt{2}m / s^2, \pi m / s, \pi\sqrt{3}m / s$

B.  $\pi m / s^2, 2\sqrt{3}m / s, \pi\sqrt{3}m / s$

C.  $\pi\sqrt{3}m / s^2, 2\sqrt{3}m / s, \pi m / s$

D. None of the above

**Answer: B**



**Watch Video Solution**

23. A uniform disc of radius 'R' is rotating about vertical axis passing through the centre in horizontal plane with constant angular speed. A massless pole AB is fixed on its circumference as shown in the figure. A light string of length  $2R$  is tied at A and a small bob at its other end. In equilibrium string makes an angle  $37^\circ$  with vertical. The angular speed of disc is (take  $R = \frac{3}{11}m$ ,  $g = 10m/s^2$ )

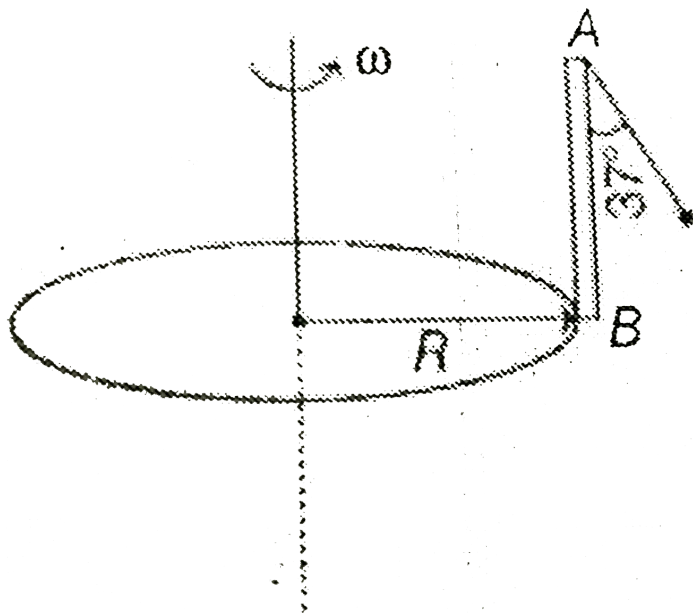

A.  $\frac{11}{\sqrt{2}}$  rad/s

B.  $7\sqrt{2}$  rad/s

C.  $4\sqrt{2}$  rad/s

D.  $\frac{5}{\sqrt{2}}$  rad/s

**Answer: D**



**Watch Video Solution**

**JEE Advanced**

1. A pendulum of length  $l = 1\text{m}$  is released from  $\theta_0 = 60^\circ$ . The rate of change of speed of the bob at  $\theta = 30^\circ$  is.

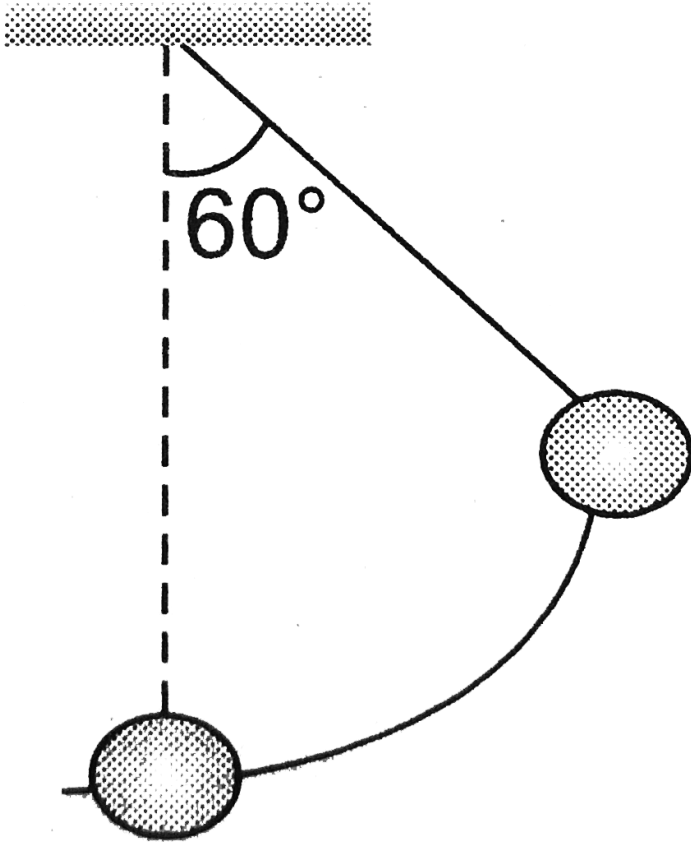

A.  $5\sqrt{3}m/s^2$

B.  $5m/s^2$

C.  $10m/s^2$

D.  $2.5m/s^2$

**Answer: B**



**Watch Video Solution**

2. A particle starts traveling on a circle with constant tangential acceleration. The angle between velocity vector and acceleration vector, at the moment when particle completes half the circular track, is

A.  $\tan^{-1}(2\pi)$

B.  $\tan^{-1}(\pi)$

C.  $\tan^{-1}(3\pi)$

D.  $\tan^{-1}(2)$

**Answer: A**



**Watch Video Solution**

3. A block of mass  $m$  is placed inside a smooth hollow cylinder of radius  $R$  kept horizontally. Initially system was at rest. Now cylinder is given constant acceleration  $2g$  in the horizontal direction by external agent. Find the maximum angular displacement of the block with the vertical.

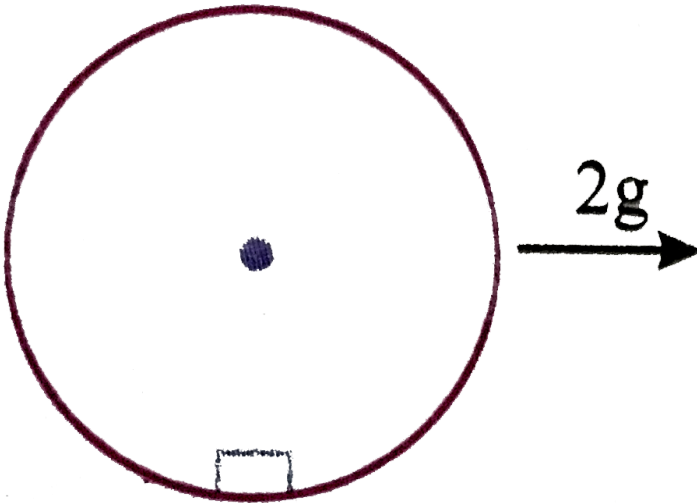

A.  $2 \tan^{-1}(2)$

B.  $\tan^{-1}(2)$

C.  $\tan^{-1}(1)$

D.  $\tan^{-1}\left(\frac{1}{2}\right)$



Answer: A

 Watch Video Solution

4. A simple pendulum is vibrating with an angular amplitude of  $90^\circ$  as shown in figure. For what value of  $\alpha$  (angle between string and vertical) during its motion, the total acceleration is directed horizontally?

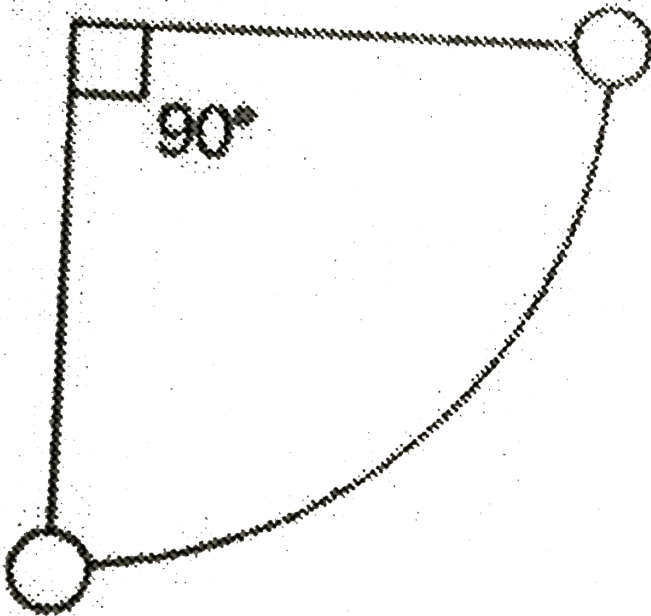

A.  $\tan^{-1}\left(\frac{1}{2}\right)$

B.  $\tan^{-1}\left(\frac{1}{\sqrt{2}}\right)$

C.  $\cos^{-1}(1/\sqrt{3})$

D.  $\sin^{-2}(1/\sqrt{3})$

Answer: C

 Watch Video Solution

5. A ball of mass  $m$  is attached to one end of a light rod of length  $l$ , the other end of which is hinged. What minimum velocity  $v$  should be imparted to the ball downwards, so that it can complete the circle ?

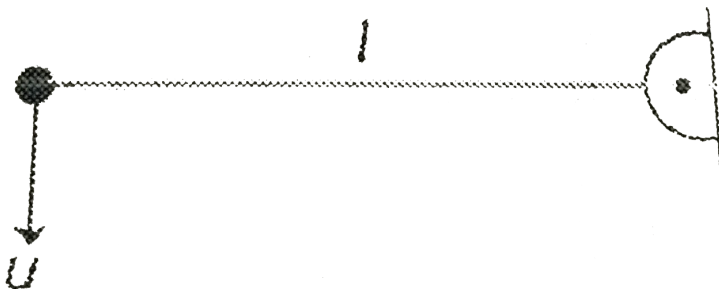

A.  $\sqrt{gl}$

B.  $\sqrt{5gl}$

C.  $\sqrt{3gl}$

D.  $\sqrt{2gl}$

Answer: D

 Watch Video Solution

6. A particle is given an initial speed  $u$  inside a smooth spherical shell of radius  $R$  so that it is just able to complete the circle. Acceleration of the particle, when its velocity is vertical, is

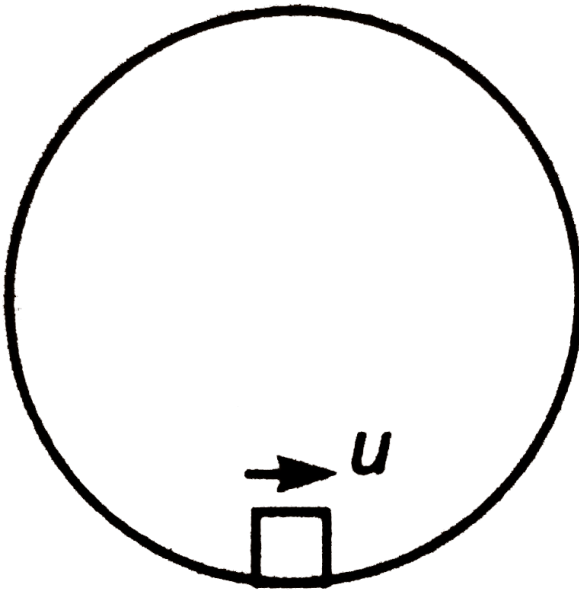

A.  $g\sqrt{10}$

B.  $g$

C.  $g\sqrt{2}$

D.  $3g$

Answer: A

 Watch Video Solution

7. A bob is suspended from a crane by a cable of length  $l = 5m$ . The crane and load are moving at a constant speed  $v_0$ . The crane is stopped by a bumper and the cable swings out an angle of  $60^\circ$ . Find the initial speed  $v_0$ . ( $g = 9.8m/s^2$ )

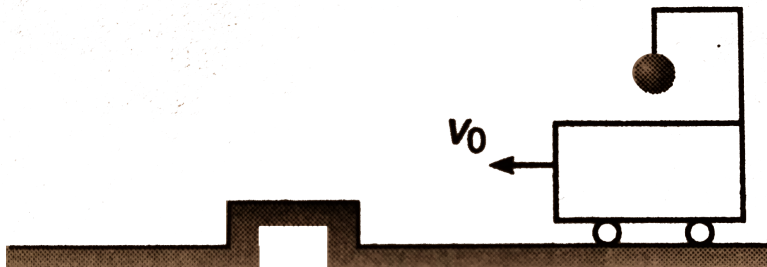

A. 10 m/s

B. 7 m/s

C. 4 m/s

D. 2 m/s

**Answer: B**

 [Watch Video Solution](#)

8. A smooth sphere of radius  $R$  is made to translate line with a constant acceleration  $a=g$ . A particle kept on the top of the sphere is released from there at zero velocity with respect to the sphere. Find the speed of the particle with respect to the sphere as a function of angle  $\theta$  as it slides down.

A.  $\frac{\sqrt{Rg(\sin \theta + \cos \theta)}}{2}$

B.  $\sqrt{Rg(1 + \cos \theta - \sin \theta)}$

C.  $\sqrt{4Rg \sin \theta}$

$$D. \sqrt{2Rg(1 + \sin \theta - \cos \theta)}$$

Answer: D

 Watch Video Solution

9. Two bodies of masses  $m$  and  $4m$  are attached with string as shown in the figure. The body of mass  $m$  hanging from a string of length  $l$  is executing oscillations of angular amplitude  $\theta_0$  while the other body is at rest. The minimum coefficient of friction between the mass  $4m$  and the horizontal surface should be

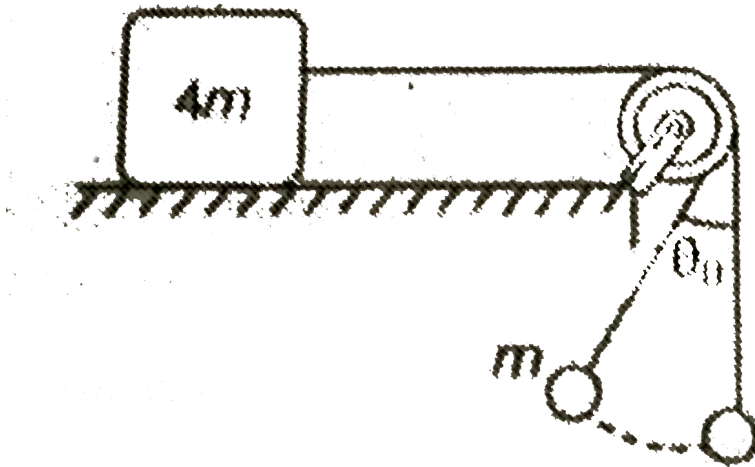

A.  $\left(\frac{2 - \cos \theta_0}{3}\right)$

B.  $2 \cos^2\left(\frac{\theta_0}{2}\right)$

C.  $\left(\frac{1 - \cos \theta_0}{2}\right)$

D.  $\left(\frac{3 - 2 \cos \theta_0}{4}\right)$

**Answer: D**



**Watch Video Solution**

**10.** Two beads A and B of equal mass  $m$  are connected by a light inextensible chord. They are constrained to move on a frictionless ring in vertical plane. The blocks are released from rest as shown in figure. The

tension in the chord just after the release is

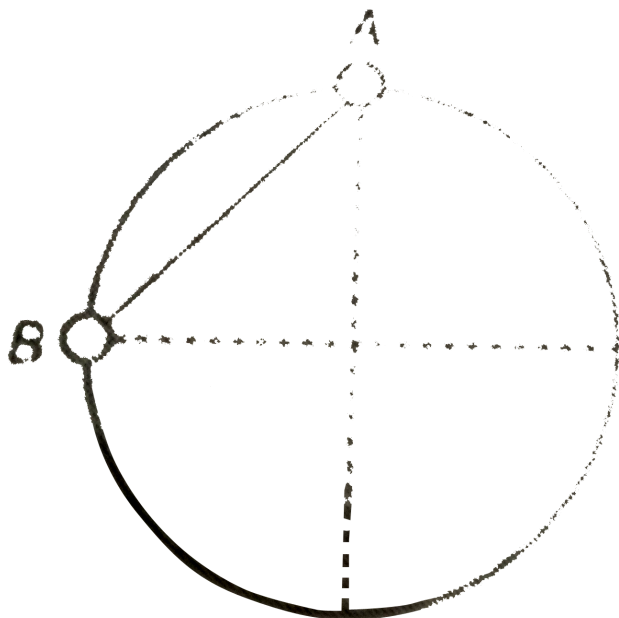

- A.  $\frac{mg}{4}$
- B.  $\sqrt{2}mg$
- C.  $\frac{mg}{2}$
- D.  $\frac{mg}{\sqrt{2}}$

**Answer: D**



**Watch Video Solution**



11. A small block of mass  $m$  is released from rest from point A inside a smooth hemispher bowl of radius  $R$ , which is fixed on ground such that OA is horizontal. The ratio ( $x$ ) of magnitude of centripetal force and normal reaction on the block at any point B varies with  $\theta$  as :

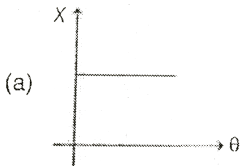
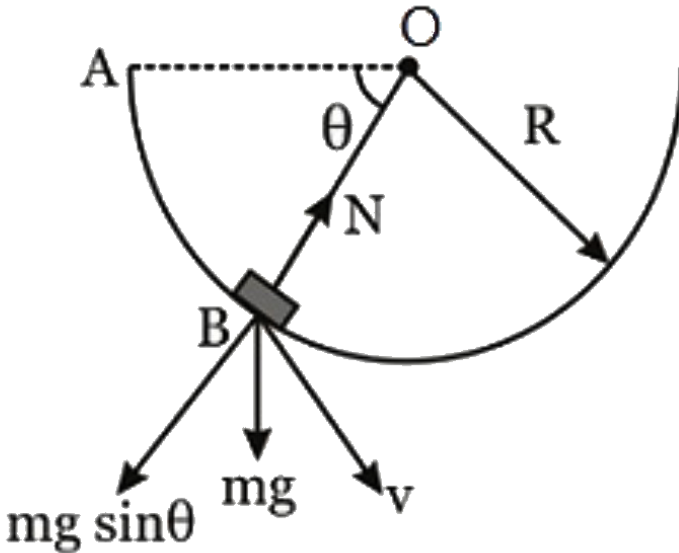

A.

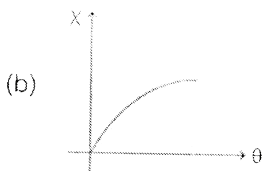

B.

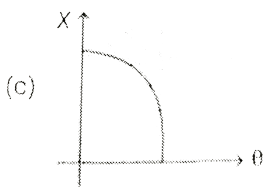

C.

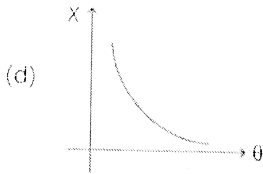

D.

**Answer: A**



**Watch Video Solution**

**12.** An automobile enters a turn whose radius is  $R$ . The road is banked at angle  $\theta$ . Friction is negligible between wheels of the automobile and road, Mass of automobile is  $m$  and speed is  $v$ . Select the correct alternative.

A. net force on the automobile is zero

B. normal reaction on the automobile is  $mg \cos \theta$

C. normal reaction on the automobile is  $mg \sec \theta$

D. net force on the automobile is  $\sqrt{(mg)^2 + (mv^2/R)^2}$

Answer: C

 Watch Video Solution

13. A ball of mass 1 kg is released from position A inside a wedge with a hemispherical cut of radius 0.5 m as shown in figure. The force exerted by the wedge on ball, when the ball is in position B is (neglect friction everywhere) (Take  $g = 10\text{ m/s}^2$ )

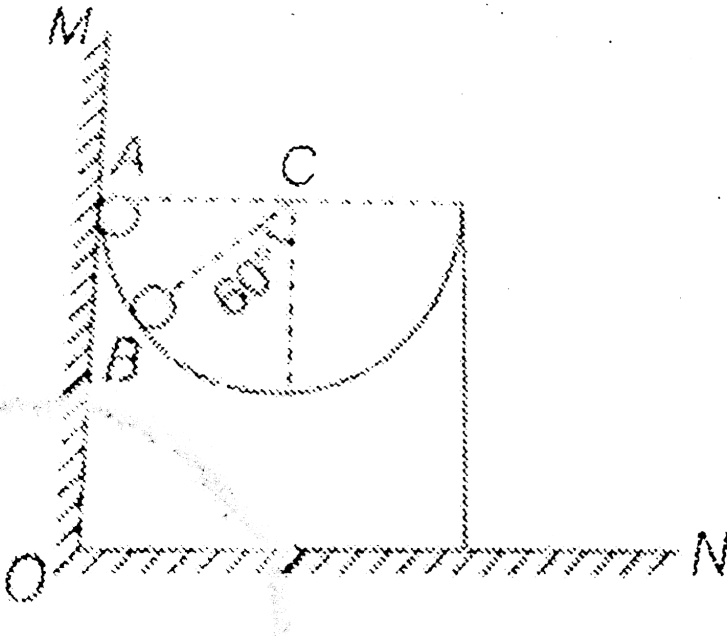

A. 10 N

B.  $5\sqrt{3}N$

C.  $\frac{15\sqrt{3}}{2}N$

D. 15 N

**Answer: C**



**Watch Video Solution**

**14.** A partical of mass  $m$  oscillates along the horizontal diameter  $AB$  inside a smooth spherical  $AB$  inside a smooth sperical shell of radius  $R$ . At any instate  $K$ .  $E$ . of the partical is  $K$ . Then force applied by partical

on the on the shell at this instant is:

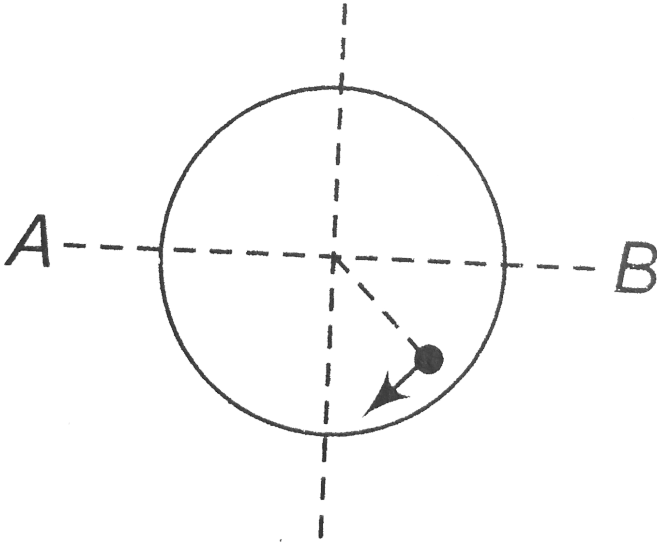

- A.  $\frac{K}{R}$
- B.  $\frac{2K}{R}$
- C.  $\frac{3K}{R}$
- D.  $\frac{K}{2R}$

**Answer: C**



**Watch Video Solution**

15. A bead of mass  $m$  is attached to one end of a spring of natural length  $R$  and spring constant  $K = \frac{(\sqrt{3} + 1)mg}{R}$ . The other end of the spring is fixed at a point A on a smooth vertical ring of radius  $R$  as shown in fig. The normal reaction at B just after it is released to move is

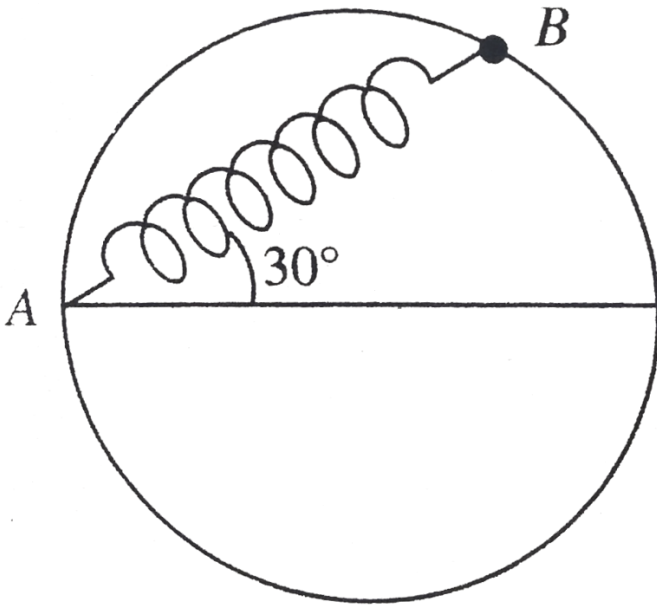

- A.  $\frac{mg}{2}$
- B.  $\sqrt{3}mg$
- C.  $3\sqrt{3}mg$
- D.  $\frac{3\sqrt{3}mg}{2}$

**Answer: D**



[Watch Video Solution](#)

16. A particle is moving in a circular path. The acceleration and momentum of the particle at a certain moment are  $a = (4\hat{i} + 3\hat{j})m/s^2$  and  $p = (8\hat{i} - 6\hat{j})\text{kg}\cdot\text{m}/\text{s}$ . The motion of the particle is

- A. uniform circular motion
- B. accelerated circular motion
- C. deaccelerated circular motion
- D. we cannot say anything with a and p only

**Answer: B**



[Watch Video Solution](#)

17. A ball of mass 'm' is rotating in a circle of radius 'r' with speed v inside a smooth cone as shown in figure. Let N be the normal reaction on the ball by the cone .then choose the wrong option.

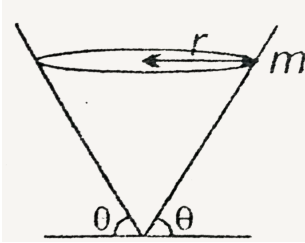

A.  $N = mg \cos \theta$

B.  $g \sin \theta = \frac{v^2}{r} \cos \theta$

C.  $N \sin \theta - \frac{mv^2}{r} = 0$

D. None of these

**Answer: A**

[▶ Watch Video Solution](#)

18. A block of mass  $m = 1\text{kg}$  has a speed  $v = 4\text{m/s}$  at  $\theta = 60^\circ$  on a circular track of radius  $R = 2\text{ m}$  as shown in figure. Size of the block is



negligible. Coefficient of friction between block and the track is  $\mu = 0.5$ .

The force of friction between the two is

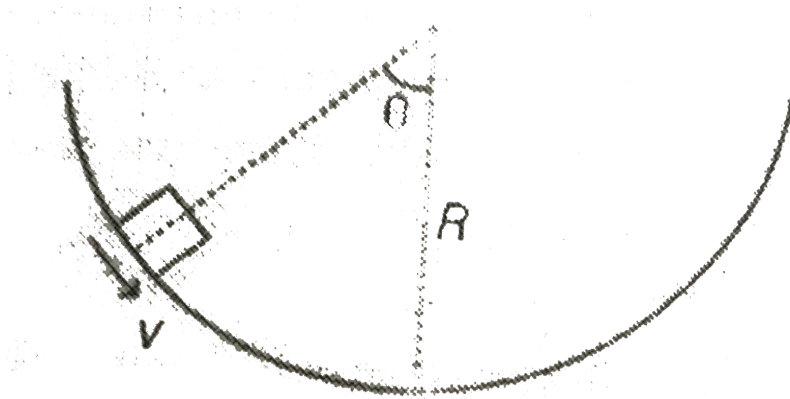

A. 10 N

B. 8.5 N

C. 6.5 N

D. 5 N

**Answer: C**



**Watch Video Solution**

19. Two blocks of masses 1 kg and 2 kg are joined by a massless inextensible string of length 3m. Both blocks are kept on a horizontal table as shown. Friction coefficient between 2 kg block and table is zero. They are rotated about a vertical axis passing at a distance of 1m from 1 kg. Force of friction on 1kg block is (assume that there is enough friction between 1 kg block ground)

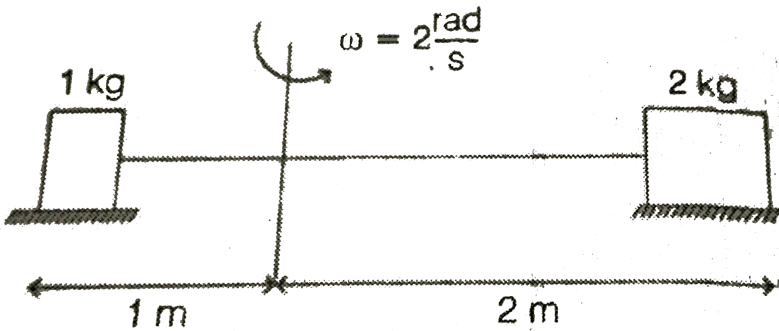

- A. 12 N towards centre
- B. 20 N towards centre
- C. 20 N away from the centre
- D. 12 N away from the centre

Answer: C

20. Two different blocks of equal mass  $m$  are released from two positions as shown in figure. Net force on the block at bottommost point in case (i) is say  $F_1$  and in case (ii) is say  $F_2$ . Then

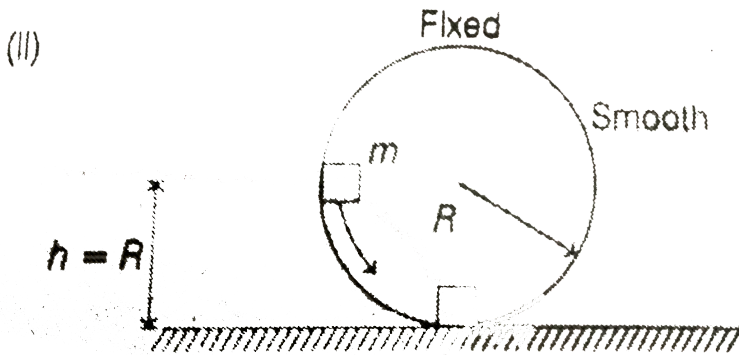
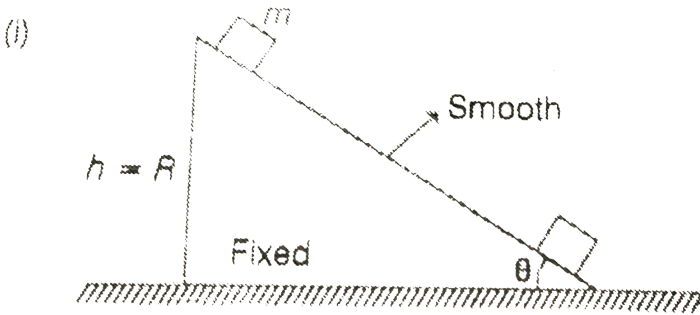

A.  $F_1 = F_2$

B.  $F_1 > F_2$

C.  $F_1 < F_2$

D. Data insufficient

Answer: C

 Watch Video Solution

21. Choose the correct option:

A small collar of mass  $m$  is given an initial velocity of magnitude  $v_0$  on the horizontal circular track fabricated from a slender rod. If the coefficient of kinetic friction is  $\mu_K$ , determine the distance traveled before the collar comes to rest. (Recognize that the friction force depends on the net normal force).

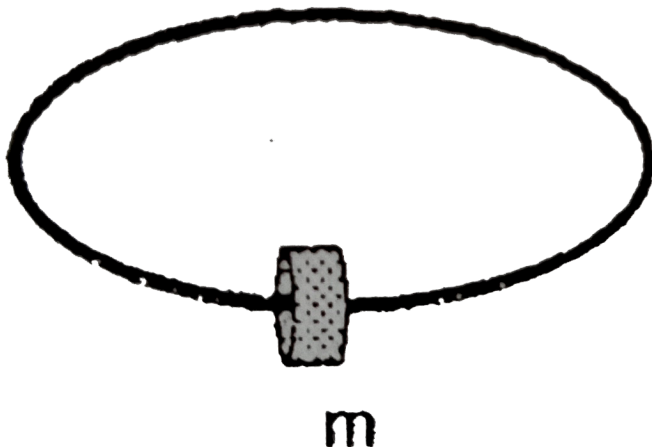

- A. (a)  $\frac{r}{\mu} \ln \left[ \frac{v_0^2 + \sqrt{v_0^4 + r^2 g^2}}{rg} \right]$
- B. (b)  $\frac{r}{4\mu} \ln \left[ \frac{v_0^2 + \sqrt{v_0^4 + r^2 g^2}}{rg} \right]$
- C. (c)  $\frac{2r}{\mu} \ln \left[ \frac{v_0^2 + \sqrt{v_0^4 + r^2 g^2}}{rg} \right]$
- D. (d)  $\frac{r}{2\mu} \ln \left[ \frac{v_0^2 + \sqrt{v_0^4 + r^2 g^2}}{rg} \right]$

**Answer: D**



**Watch Video Solution**

**22.** A small ball is rolled with speed  $u$  from point A along a smooth circular track as shown in figure. If  $x = 3R$ , then

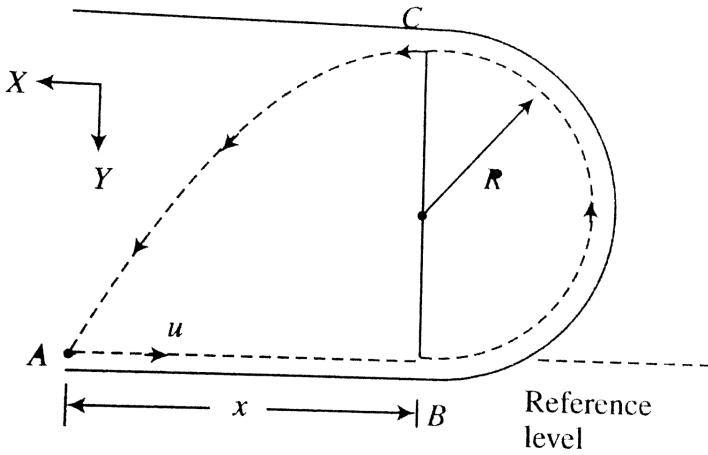

Determine the required speed  $u$  so that the ball returns to A, the point of projection after passing through C, the highest point.

- A.  $\frac{3}{2}\sqrt{gR}$
- B.  $\frac{1}{2}\sqrt{gR}$
- C.  $\frac{9}{2}\sqrt{gR}$
- D. None of these

**Answer: D**

 [Watch Video Solution](#)

23. A smooth circular track of mass  $M$  is vertically hung by a string down the ceiling. Two small rings, each of mass  $m$ , are initially at rest at the top of the track. They then slide down simultaneously along the track in opposite directions. Find the position of the rings when the tension in the string is zero.

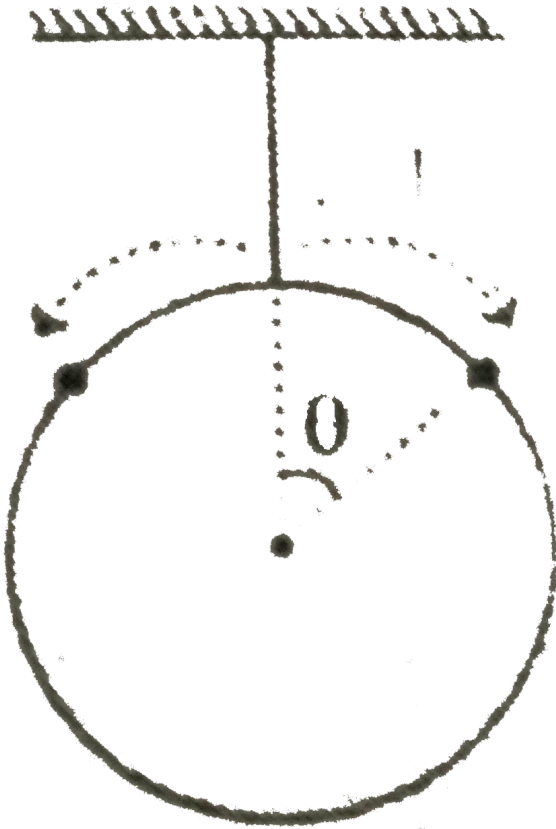

$$A. \theta = \sin^{-1} \left[ \frac{1}{3} \left( 1 + \sqrt{1 - \frac{GM}{3m}} \right) \right]$$

$$\text{B. } \theta = \cos^{-1} \left[ \frac{5}{3} \left( 1 + \sqrt{1 - \frac{3M}{2m}} \right) \right]$$

$$\text{C. } \theta = \cos^{-1} \left[ \frac{1}{3} \left( 1 + \sqrt{1 - \frac{3M}{2m}} \right) \right]$$

$$\text{D. } \theta = \cos^{-1} \left[ \frac{1}{3} \left( 1 + \sqrt{1 - \frac{5M}{3m}} \right) \right]$$

**Answer: C**

 [Watch Video Solution](#)

**24.** A particle of mass  $m$ , moving in a circle of radius  $R$ , has a velocity  $v = v_0(1 - e^{-\gamma t})$ . The power delivered to the particle by the force at  $t = 0$  is

 [Watch Video Solution](#)

**More than One Option is Correct**

**1.** A particle is moving on a circular path of radius 1 m with 2 m/s. If speed starts increasing at a rate of  $2m/s^2$ , then acceleration of particle is



A. distance travelled by the particle is 4m

B. displacement of the particle is  $2 \sin 2$

C. average speed of the particle is 2 m/s

D. average velocity of the particle is zero

**Answer: A::B::C**

 [Watch Video Solution](#)

2. During uniform circular motion of a particle

A. distance-time graph is a straight line

B. distance-time graph is a parabola

C. displacement-time graph is a straight line

D. displacement-time graph is a parabola

**Answer: A**

 [Watch Video Solution](#)

3. A small spherical ball is suspended through a string of length  $l$ . The whole arrangement is placed in a vehicle which is moving with velocity  $v$ . Now, suddenly the vehicle stops and ball starts moving along a circular path. If tension in the string at the highest point is twice the weight of the ball then (assume that the ball completes the vertical circle)

A.  $v = \sqrt{5gl}$

B.  $v = \sqrt{7gl}$

C. velocity of the ball at highest point is  $\sqrt{gl}$

D. velocity of the ball at the highest point is  $\sqrt{3gl}$

**Answer: B::D**



**Watch Video Solution**

4. In the system shown in the figure the mass  $m$  moves in a circular arc of angular amplitude  $60^\circ$ . Mass  $4m$  is stationary. Then :

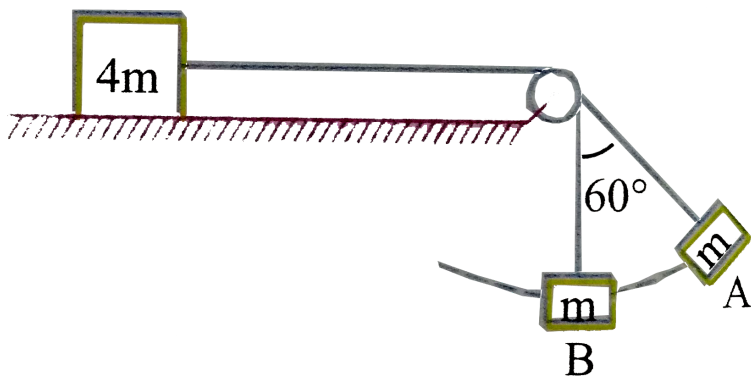

- A. the minimum value of coefficient of friction between the mass  $4m$  and the surface of the table is 0.50
- B. the work done by gravitational force on the block  $m$  is positive when it moves from A to B
- C. the power delivered by the tension when  $m$  moves from A to B is zero
- D. the kinetic energy of  $m$  in position B equals the work done by gravitational force on the block when it moves from position A to B

**Answer: A::B::C::D**



**Watch Video Solution**

5. A small block of mass  $m$  is released from rest from position A inside a smooth hemispherical bowl of radius  $R$  as shown in figure. Choose the wrong option.

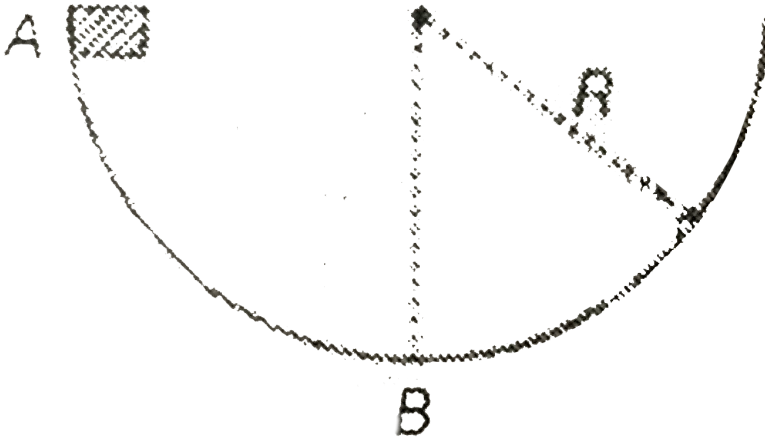

- A. Acceleration of block is constant throughout
- B. Acceleration of block is  $g$  at A
- C. Acceleration of block is  $3g$  at B
- D. Acceleration of block is  $2g$  at B

Answer: A::C



Watch Video Solution

6. A curved road is banked for speed  $v_0$ . When a car moves along the road with a constant speed  $v$ , the force the friction between the road and the tyres is  $F$ . Which of the following statements(s) is (are) correct ?

- A. If  $v = 0$ ,  $F = 0$
- B. If  $v = < v_0$ ,  $F$  acts outwards
- C. If  $v > v_0$ ,  $F$  acts inwards
- D. If  $v = v_0$ ,  $F = 0$

**Answer: B::C::D**



[Watch Video Solution](#)

7. A block of mass  $m$  is moving in a circle of radius  $R$  with speed  $v$  inside a smooth cone as shown in figure. Choose the wrong options

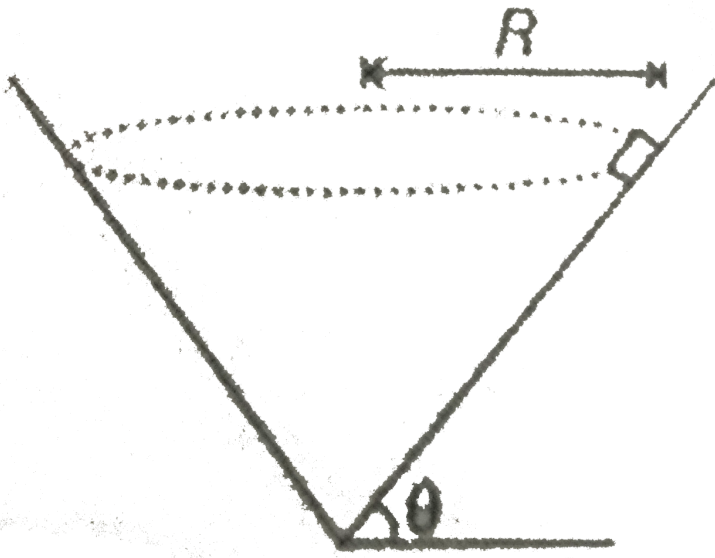

A. (a)  $N=0$  if  $v = \sqrt{Rg \tan \theta}$

B. (b)  $N \sin \theta = \frac{mv^2}{R}$

C. (c) Block is in equilibrium

D. (d) Block is accelerated

Answer: A:C



Watch Video Solution

8. A stone is tied to a string and swings with uniform motion in a horizontal circle. The string breaks and at a time  $t$ , the stone is displaced  $\Delta r = 3\hat{i} + 4\hat{j} - 5\hat{k}$  metres. (The positive  $z$ -axis is vertically up) Select the correct alternative.

A. the time  $t$  is 1 s

B. the time  $t$  is 0.5 s

C. the speed of the stone while in circular motion is 5 m/s

D. the speed of the stone while in circular motion is  $5\sqrt{2} \text{ m/s}$

**Answer: A::C**



[Watch Video Solution](#)

9. In the figure, the block on the smooth table is set into motion in a circular orbit of radius  $r$  around the centre hole. The hanging mass is identical to the mass on the table and remains in equilibrium. Neglect friction. The string connecting the two blocks is massless and

inextensible. Select the correct alternatives.

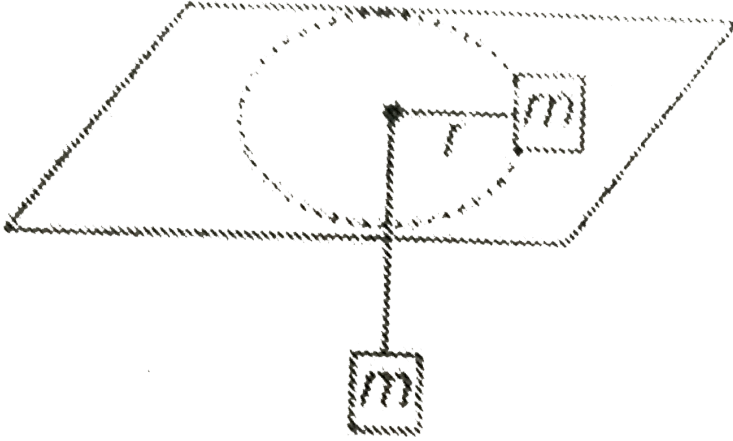

- A. The angular speed  $\omega$  of the block in its circular motion is  $\sqrt{\frac{g}{r}}$
- B. Kinetic energy as function of  $r$  is given by  $\frac{mgr}{2}$
- C. Angular momentum about the hole is conserved
- D. The block on table is in equilibrium

**Answer: A::B::C**



**Watch Video Solution**



10. Acceleration of a particle in x-y plane varies with time as  $a = (2t\hat{i} + 3t^2\hat{j}) m/s^2$ . At time  $t = 0$ , velocity of particle is  $2m/s$  along positive x direction and particle starts from origin. Find velocity and coordinates of particle at  $t = 1s$ .

A. acceleration of particle is  $8m/s^2$

B. tangential acceleration of particle is  $\frac{6}{\sqrt{5}} m/s^2$

C. radial acceleration of particle is  $\frac{2}{\sqrt{5}} m/s^2$

D. radius of curvature to the path is  $\frac{5\sqrt{5}}{2} m$

**Answer: B::C::D**



**Watch Video Solution**

11. For a car taking a turn on a horizontal surface, let  $N_1$  and  $N_2$  be the normal reactions of the road on the inner and outer wheels respectively

A.  $N_1 > N_2$

B.  $N_2 > N_1$

C.  $N_1 = N_2$

D. the maximum value of  $v$  to avoid overturning is  $\sqrt{\frac{arg}{h}}$

**Answer: B::D**



**Watch Video Solution**

**12.** A small sphere of mass  $m$  is connected by a string to a nail at  $O$  and moves in a circle of radius  $r$  on the smooth plane inclined at an angle  $\theta$  with the horizontal. If the sphere has a velocity  $u$  at the top position A. Mark the correct options.

1) the tension in the string as the sphere passes the  $90^\circ$  position B is equal to  $m(u^2/l - 2g\sin\theta)$

2) the tension in the string at the bottom most position C is equal to  $m(u^2/l + 5g\sin\theta)$

3) the tension in the string as the sphere passes the  $90^\circ$  position B is equal to  $m(u^2/l + 2g\sin\theta)$

4) the tension in the string at the bottom most position C is equal to

$$m \left( \frac{u^2}{l} - 5g \sin \theta \right)$$

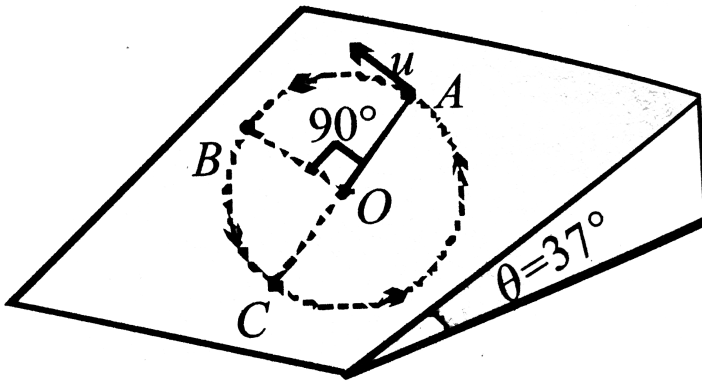

A. the tension in the string as the sphere passes the  $90^\circ$  position B is

$$\text{equal to } m \left( \frac{u^2}{l} - 2g \sin \theta \right)$$

B. the tension in the string at the bottom most position C is equal to

$$m \left( \frac{u^2}{l} + 5g \sin \theta \right)$$

C. the tension in the string as the sphere passes the  $90^\circ$  position B is

$$\text{equal to } m \left( \frac{u^2}{l} + 2g \sin \theta \right)$$

D. the tension in the string at the bottom most position C is equal to

$$m \left( \frac{u^2}{l} - 5g \sin \theta \right)$$

Answer: B::C

 Watch Video Solution

13. A particle of mass ' $m$ ' is moving in horizontal circle inside a smooth inverted fixed vertical cone above height ' $h$ ' from apex. Angle of cone is  $\theta$ , then

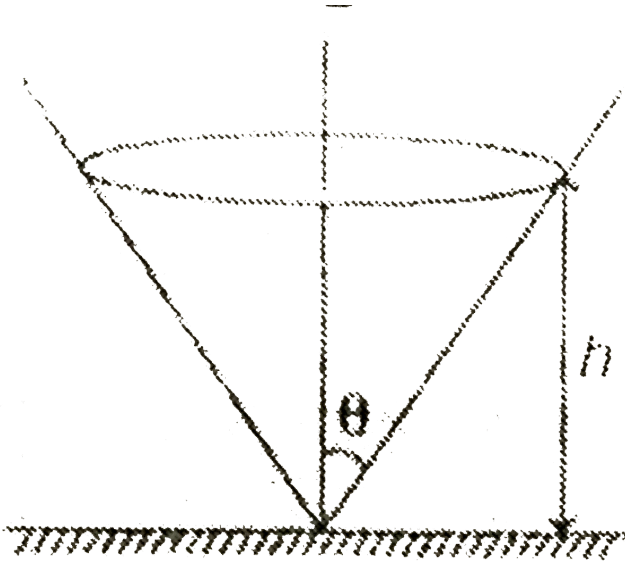

- A. Normal force on particle by surface of cone is  $mg \cos \theta$
- B. Normal force on particle by surface of cone is  $mg \cos e\theta$

C. Time period of revolution of particle increases, if  $\theta$  increase keeping

$h$  constant

D. Time period of revolution increases, if  $h$  increases keeping  $\theta$  fixed.

**Answer: B::C::D**



**Watch Video Solution**

## Comprehension

1. A particle is moving in a circle of radius  $R$  with constant speed. The time period of the particle is  $T$ . In a time  $t = \frac{T}{6}$

Average speed of the particle is .....

A.  $\frac{\pi R}{6T}$

B.  $\frac{2\pi R}{3T}$

C.  $\frac{2\pi R}{T}$

D.  $\frac{R}{T}$

**Answer: C**



**Watch Video Solution**

2. A particle is moving in a circle of radius  $R$  with constant speed. The time period of the particle is  $T$ . In a time  $t = \frac{T}{6}$

Average velocity of the particle is.....

A.  $\frac{3R}{T}$

B.  $\frac{6R}{T}$

C.  $\frac{2R}{T}$

D.  $\frac{4R}{T}$

**Answer: B**



**Watch Video Solution**

3. A bob of mass 1 kg is suspended from an inextensible string of length 1 m. When the string makes an angle  $60^\circ$  with vertical, speed of the bob is 4 m/s

Net acceleration of the bob at this instant is

A.  $16m / s^2$

B.  $20.4m / s^2$

C.  $18.2m / s^2$

D.  $10.4m / s^2$

**Answer: C**



**Watch Video Solution**

4. A bob of mass 1 kg is suspended from an inextensible string of length 1 m. When the string makes an angle  $60^\circ$  with vertical, speed of the bob is 4 m/s

Upto what maximum height will the bob rise with respect to the bottommost point ?

A. 1.6 m

B. 1.8 m

C. 1.3 m

D. 2 m

**Answer: C**



[Watch Video Solution](#)

5. A block is released from height ( $\neq 0$ ) on a rough track AB as shown in figure. Coefficient of friction between the block and the surface is  $\mu = 0.5$ . Track BC is smooth. From C onwards there is a circular smooth track of radius  $R = 50$  cm



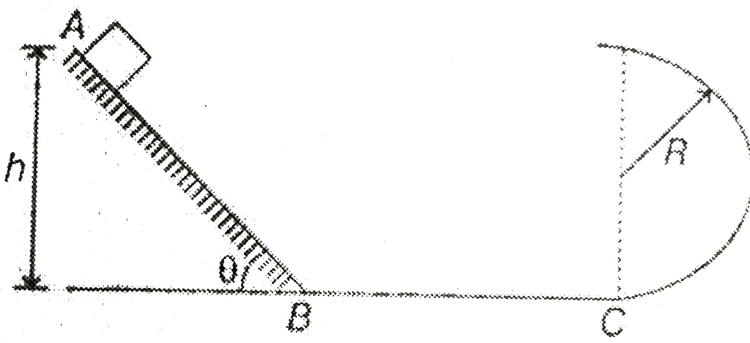

For what value of  $h$  block does not leave contact with any surface ? Given,

$$\tan \theta = \frac{3}{4} \text{ and } g = 10 \text{ m/s}^2$$

- A.  $h = 2.5 \text{ m}$
- B.  $h \leq 2.0 \text{ m}$
- C.  $h = 2.0 \text{ m}$
- D.  $h \leq 1.5 \text{ m}$

**Answer: D**

[▶ Watch Video Solution](#)

6. A block is released from height ( $\neq 0$ ) on a rough track AB as shown in figure. Coefficient of friction between the block and the surface is  $\mu = 0.5$

. Track BC is smooth. From C onwards there is a circular smooth track of radius  $R = 50$  cm

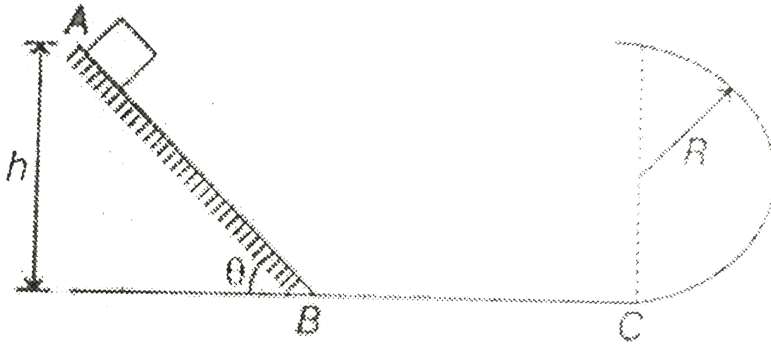

If the block is placed on the above calculate height, how many times will the block cross point C ?

- A. infinite number of times
- B. 2 times
- C. 4 times
- D. 3 times

**Answer: A**

[Watch Video Solution](#)

7. A small ball (of negligible size) is placed over a sphere of same mass and radius 1 m as shown. All surface are smooth. A slight push is given to the ball. When the radius vector joining the ball makes an angle of  $30^\circ$  with the vertical, speed of sphere is  $v$ . ( $g = 10\text{ m/s}^2$ )

Value of  $v$  in m/s is

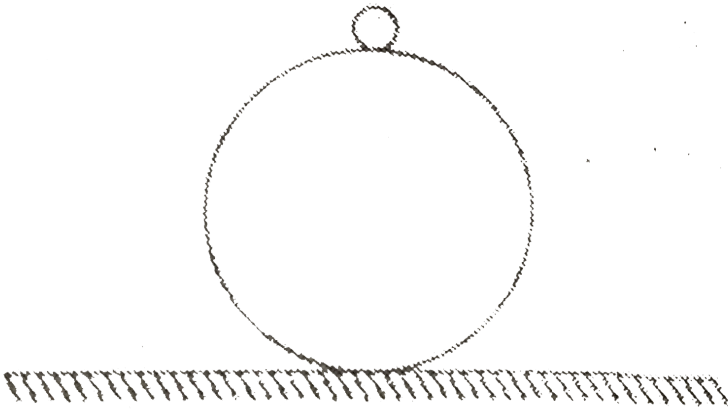

A. 0.9

B. 1.6

C. 2.4

D. 0.4

**Answer: A**



8. A small ball (of negligible size) is placed over a sphere of same mass and radius 1 m as shown. All surface are smooth. A slight push is given to the ball. When the radius vector joining the ball makes an angle of  $30^\circ$  with the vertical, speed of sphere is  $v$ . ( $g = 10\text{ m/s}^2$ )

If mass of ball and sphere be 1 kg each then the normal reaction between the two at this instant is ?

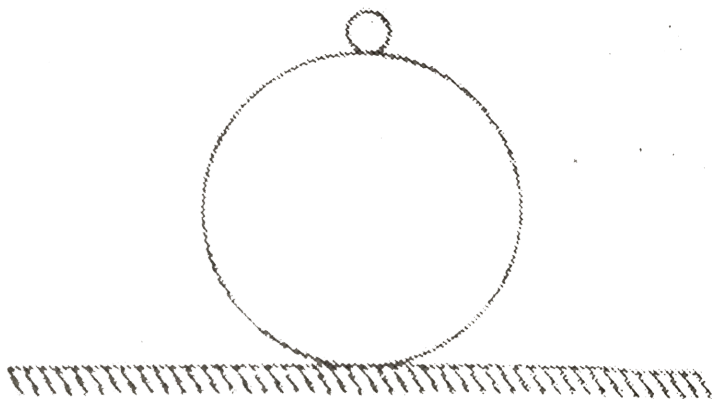

- A. 5.62 N
- B. 7.68 N
- C. 4.81 N
- D. 3.47 N

Answer: D

 Watch Video Solution

9. A small block of mass  $m$  projected horizontally from the top of the smooth and fixed hemisphere of radius  $r$  with speed  $u$  as shown. For values of  $u \geq u_0$  ( $u_0 = \sqrt{gr}$ ) it does not slide on the hemisphere. I.e., leaves the surface at the top itself.

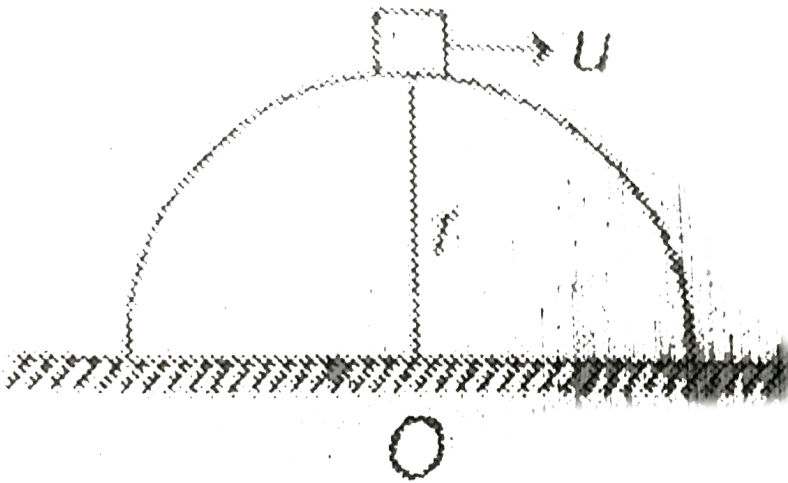

For  $u = 2u_0$ , it lands at point P on ground. Find OP.

A.  $\sqrt{2}r$

B.  $2r$

C.  $4r$

D.  $2\sqrt{2}r$

**Answer: D**



**Watch Video Solution**

**10.** A small block of mass  $m$  projected horizontally from the top of the smooth and fixed hemisphere of radius  $r$  with speed  $u$  as shown. For values of  $u \geq u_0$  ( $u_0 = \sqrt{gr}$ ) it does not slide on the hemisphere. I.e., leaves the surface at the top itself.

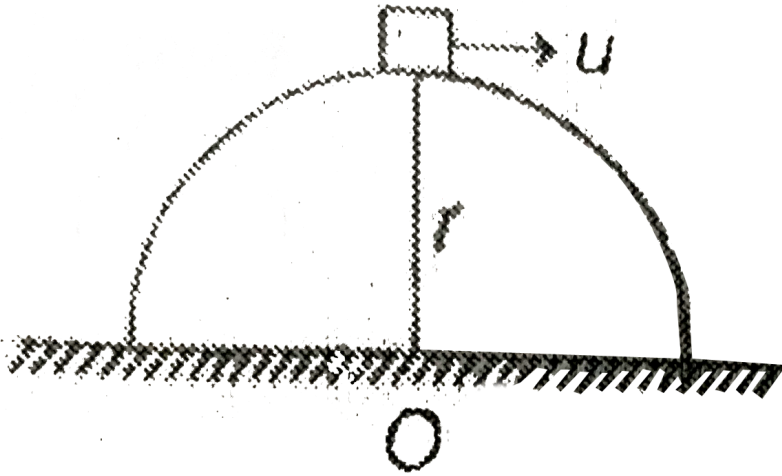

For  $u = u_0/3$ , Find the height from the ground at which it leaves the hemisphere

- A.  $\frac{19r}{9}$
- B.  $\frac{19r}{27}$
- C.  $\frac{10r}{9}$
- D.  $\frac{10r}{27}$

**Answer: B**



**Watch Video Solution**

11. A small block of mass  $m$  projected horizontally from the top of the smooth and fixed hemisphere of radius  $r$  with speed  $u$  as shown. For values of  $u \geq u_0$  ( $u_0 = \sqrt{gr}$ ) it does not slide on the hemisphere. I.e., leaves the surface at the top itself.

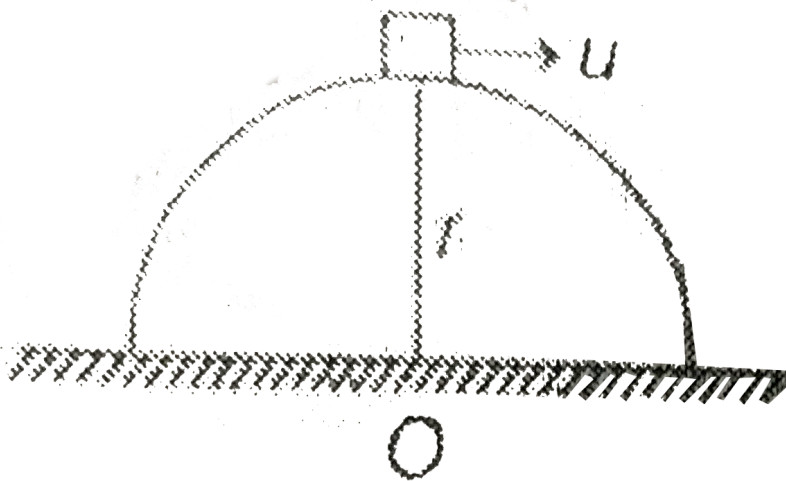

In the above problem find its net acceleration at the instant it levels the hemisphere.

- A. zero
- B.  $g/2$
- C.  $g$
- D.  $g/3$



**Answer: C**



**Watch Video Solution**

**12.** A particle of mass  $m$  is attached to one end of a light inextensible string and the other end of the string is fixed in vertical plane as shown.

Particle is given a horizontal velocity  $u = \sqrt{\frac{5}{2}gl}$

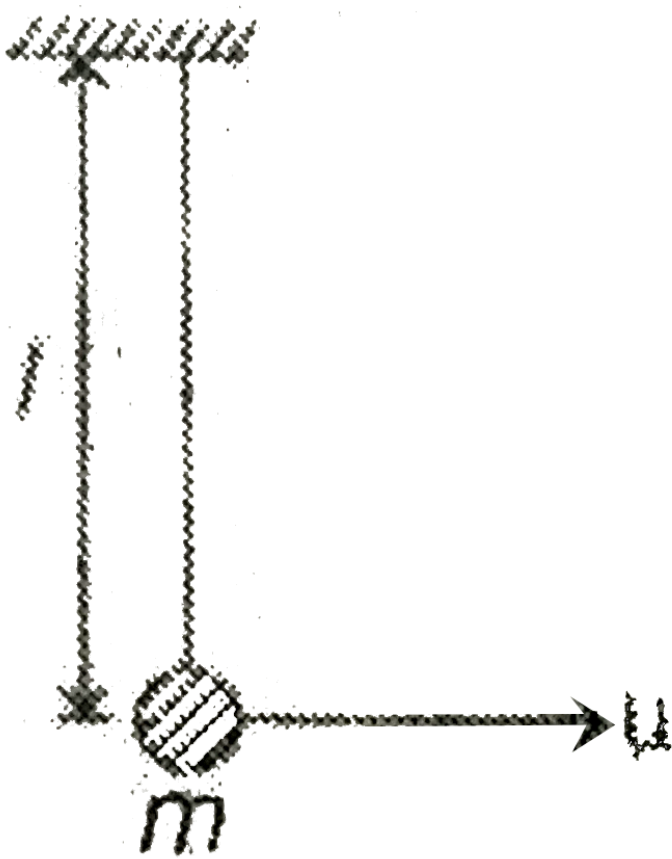

The maximum angle made by the string with downward vertical is

- A.  $\cos^{-1}\left(\frac{1}{4}\right)$
- B.  $\sin^{-1}\left(\frac{1}{4}\right)$
- C.  $\frac{\pi}{2} + \cos^{-1}\left(\frac{1}{4}\right)$
- D.  $\pi - \cos^{-1}\left(\frac{1}{4}\right)$

**Answer: D**



Watch Video Solution

13. A particle of mass  $m$  is attached to one end of a light inextensible string and the other end of the string is fixed in vertical plane as shown.

Particle is given a horizontal velocity  $u = \sqrt{\frac{5}{2}gl}$

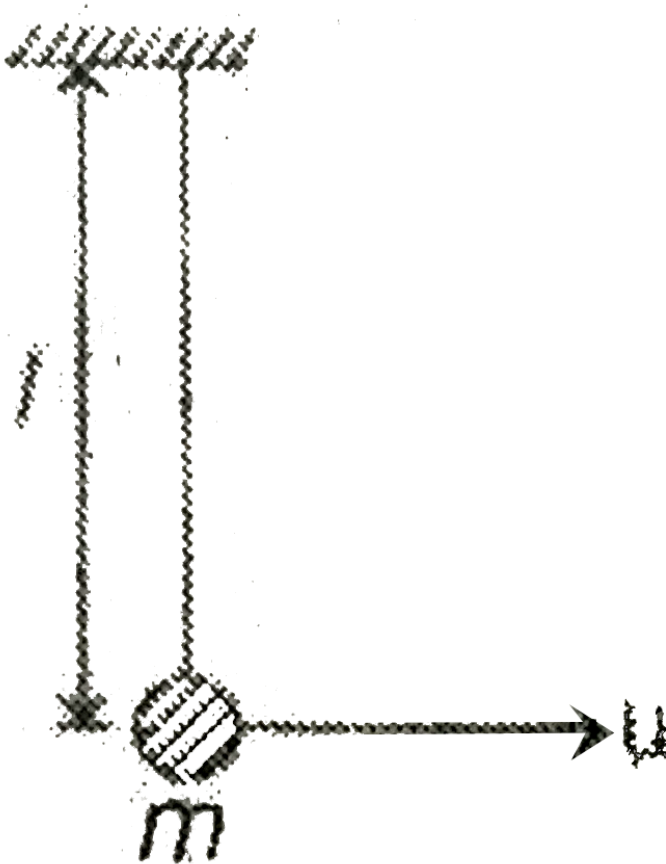

The maximum angle made by the string with downward vertical is

A. (1)mg

B. (2)2 mg

C. (3)4 mg

D. (4)6 mg

**Answer: B**



[Watch Video Solution](#)

## Matrix Matching

1. A particle is rotating in a circle of radius 1 m with constant speed 4 m/s.

In time 1s, match the following (in *SI* unit)

Table-1

Table-2

(A) Displacement

(P)  $8 \sin 2$

(B) Distance

(Q) 4

(C) Average velocity

(R)  $2 \sin 2$

(D) Average acceleration

(S)  $4 \sin 2$



[Watch Video Solution](#)

2. A particle is suspended from a string of length  $R$ . It is given a velocity  $u = 3\sqrt{gR}$  at the bottom

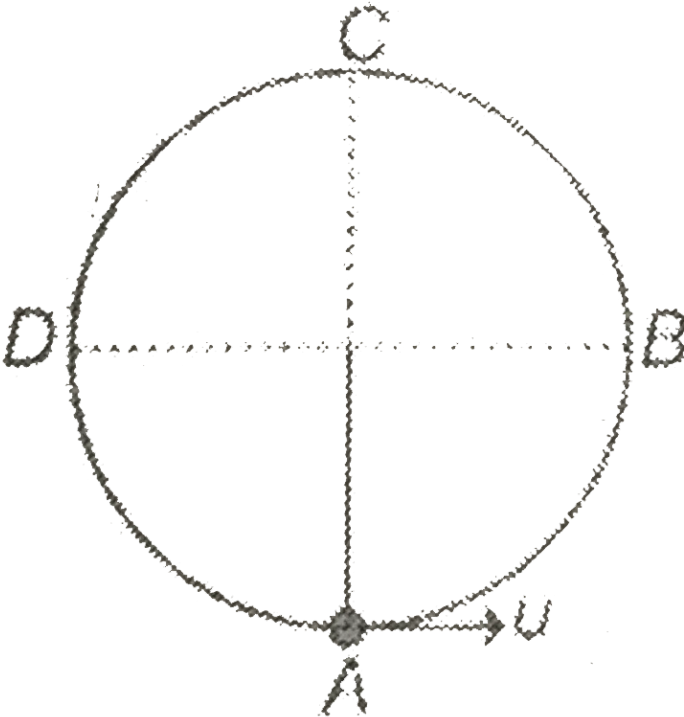

Match the following

Table-1

- (A) Velocity at B
- (B) Velocity at C
- (C) Tension in string at B
- (D) Tension in string at C

Table-2

- (P)  $7mg$
- (Q)  $\sqrt{5gR}$
- (R)  $\sqrt{7gR}$
- (S)  $5mg$
- (T) None



Watch Video Solution

3. A pendulum is released from point A as shown in figure. At some instant net force on the bob is making an angle  $\theta$  with the string. Then

Match the following

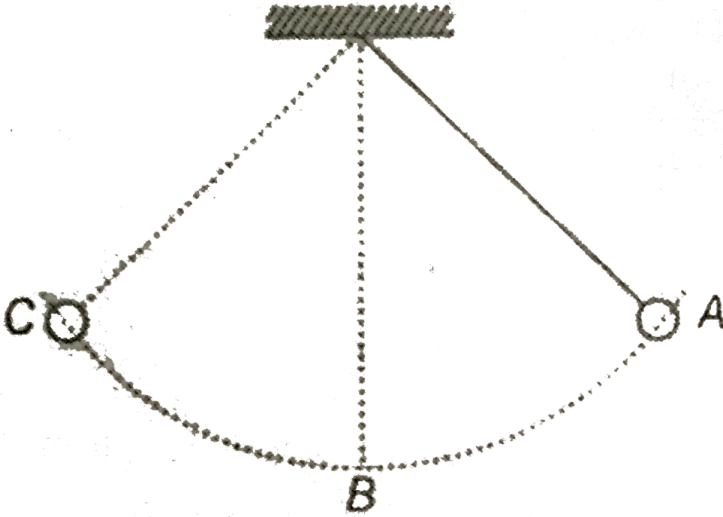

Table-1

- (A) For  $\theta = 30^\circ$
- (B) For  $\theta = 120^\circ$
- (C) For  $\theta = 90^\circ$
- (D) For  $\theta = 0^\circ$

Table-2

- (P) Particle may be moving along BA
- (Q) Particle may be moving along CB
- (R) Particle may be at A
- (S) Particle is at B
- (T) None



Watch Video Solution

4. In all the four situations depicted in Table-1, a ball of mass  $m$  is connected to a string. In each case, find the tension in the string and match the appropriate entries in Table-2

Table-1

(A)



Conical pendulum

(B)

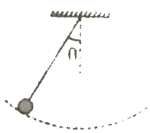

Pendulum is swinging. Angular position  $\theta$  is the extreme position.  $T$  is tension in extreme position.

(C)



The car is moving with constant acceleration. The ball is at rest with respect to car.

(D)



The car is moving with constant velocity. The ball is at rest with respect to car.

Table-2

(P)  $T = mg \cos \theta$

(Q)  $T \cos \theta = mg$

(R) Speed of ball with respect to ground is constant

(S) Velocity of ball with respect to ground is changing continuously



Watch Video Solution

5. Three balls each of mass 1 kg are attached with three strings each of length 1 m as shown in figure. They are rotated in a horizontal circle with angular velocity  $\omega = 4\text{rad s}^{-1}$  about point O. Match the following columns.

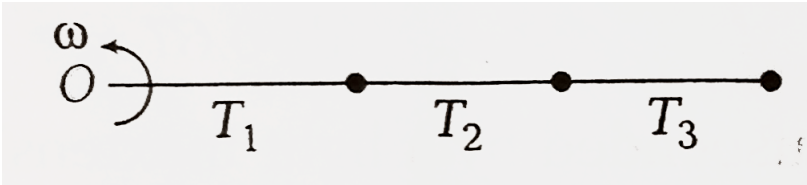

[▶ Watch Video Solution](#)

6. Each situation in Table-1 gives graph of a particle moving in circular path. The variables  $\omega$ ,  $\theta$  and  $t$  represent angular speed (at any time  $t$ ), angular displacement (in time  $t$ ) and time respectively. Table-2 gives certain resulting interpretation. Match the graphs in Table-1 with statements in Table-2.



Table-1

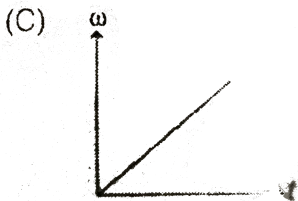
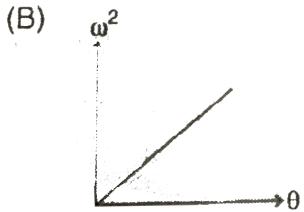
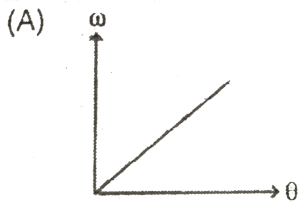

Table-2

(P) Angular acceleration of particle is uniform.

(Q) Angular acceleration of particle is non-uniform.

(R) Angular acceleration of particle is directly proportional to  $t$ .

(D)

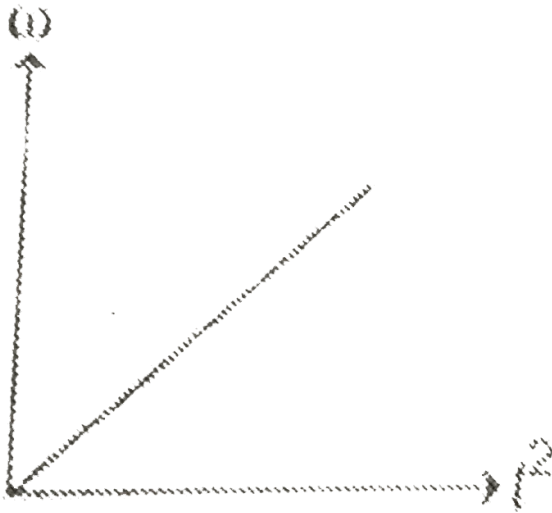

0



Watch Video Solution

7. A particle is moving with speed  $v = 2t^2$  on the circumference of a circle of radius  $R$ . Match the quantities given in Table-1 with corresponding results in Table-2

Table-1

- (A) Magnitude to tangential acceleration of particle
- (B) Magnitude of centripetal acceleration of particle
- (C) Magnitude of angular speed of particle with respect to centre of circle
- (D) Angle between the total acceleration and centripetal acceleration of p



[Watch Video Solution](#)

## Integer

1. The bob of a 0.2 m pendulum describes an arc of circle in a vertical plane. If the tension in the cord is  $\sqrt{3}$  times the weight of the bob when the cord makes an angle  $30^\circ$  with the vertical, the acceleration of the bob in that position is  $g/n$ . Find value of  $n$ .

A. 1

B. 2

C. 3

D. 5

**Answer: 1**



[Watch Video Solution](#)

2. A particle moves in a circle of radius 1 cm at a speed given  $v = 2t$ , where  $v$  is cm/s and  $t$  is in seconds. Total acceleration of the particle at  $t = 1$  second is  $2\sqrt{n} \text{ cm/s}^2$ . Find value of  $n$ .



[Watch Video Solution](#)

3. A small coin of mass 5 g is placed at a distance 5 cm from centre on a flat horizontal turn table. The turn table is observed to make 3 revolutions in  $\sqrt{10}$  s. The frictional force on the coin is  $(n \times 10^{-3}) \text{ N}$ . Find value of  $n$ .

[▶ Watch Video Solution](#)

4. As shown in the figure, a small ball is released from a certain height  $h$  which has to perform circular motion on a vertical smooth track of radius 4 m. The track is absent between point A and B. Calculate the height (in m) from where the ball has to be released so that it will reach at highest point B of the circular track.

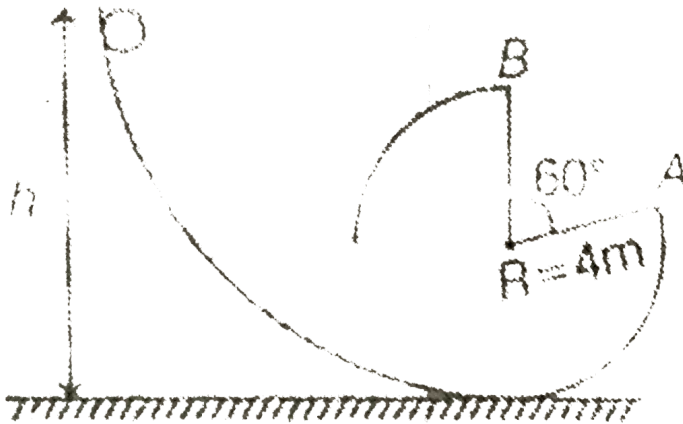

[▶ Watch Video Solution](#)

5. A rod has length ' $l$ ' and mass per unit length linearly increases from  $\lambda$  to  $2\lambda$  as shown in figure. Rod rotates with constant angular velocity  $\omega$  in

a gravity free space. Find the tension (in Newton) in the rod at its middle point. (take  $\omega l = 2m/\text{sec}$  and  $\lambda = 3\text{kg}/\text{m}$ )

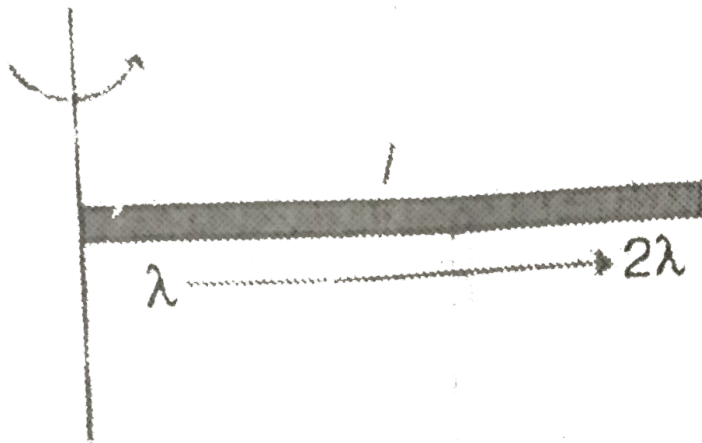

[Watch Video Solution](#)

6. A massive horizontal platform is moving horizontally with a constant acceleration of  $10m/s^2$  as shown in the figure. A particle P of mass  $m = 1\text{ kg}$  is kept at rest on a smooth surface as shown in the figure. The particle is hinged at O with the help of a massless rod OP of length 0.9 m. Hinge O is fixed on the platform and the rod can freely rotate about O. Now the particle P is imparted a velocity in the opposite direction of the platform's acceleration such that it is just able to complete the circular

motion about point O. Then the maximum tension (in N) appearing in the rod during the motion is 10 n. Find the value of  $n$

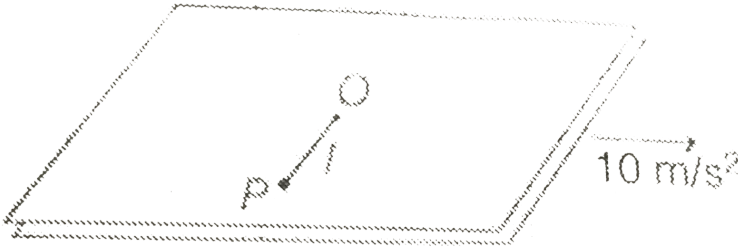

[▶ Watch Video Solution](#)

7. A mass  $m_1$  lies on a fixed smooth cylinder. An ideal chord attached to  $m_1$  passes over the cylinder and is connected to  $m_2$ . The system is released at  $\theta = 30^\circ$ . Acceleration of  $m_1$  just after releasing the system is  $\frac{5}{n} \text{ m/s}^2$ . Find the value of  $n$ .

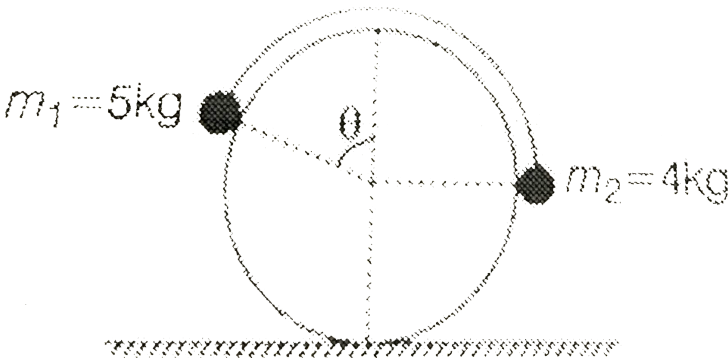



Watch Video Solution

## Check point

1. If a flywheel makes  $120 \text{ rev/min}$ , then its angular speed will be

A.  $2\pi \text{ rad s}^{-1}$

B.  $4\pi^2 \text{ rad s}^{-1}$

C.  $\pi \text{ rad s}^{-1}$

D.  $4\pi \text{ rad s}^{-1}$

**Answer: D**



Watch Video Solution

2. The ratio of angular speeds of minute hand and hour hand of a watch is

is

A. 1: 12

B. 6: 1

C. 12: 1

D. 1: 6

**Answer: C**



**Watch Video Solution**

3. The wheel of a toy car rotates about a fixed axes. It slows down from 400 rps to 200 rps in 2 s. Then, its angular retardation in  $\text{rad s}^{-2}$  is (rps = revolutions per second)

A.  $200\pi$

B.  $100\pi$

C.  $400\pi$

D. None of these



**Answer: A**



**Watch Video Solution**

4. A rotating wheel changes angular speed from 1800 rpm to 3000 rpm in 20 s. What is the angular acceleration assuming to be uniform?

A.  $60\pi \text{ rad s}^{-2}$

B.  $90\pi \text{ rad s}^{-2}$

C.  $2\pi \text{ rad s}^{-2}$

D.  $40\pi \text{ rad s}^{-2}$

**Answer: C**



**Watch Video Solution**

5. A wheel is rotating at 900 rpm about its axis. When the power is cut off, it comes to rest in 1 min. The angular retardation (in  $\text{rad s}^{-2}$ ) is

A.  $\frac{\pi}{2}$

B.  $\frac{\pi}{4}$

C.  $\frac{\pi}{6}$

D.  $\frac{\pi}{8}$

**Answer: A**



[Watch Video Solution](#)

6. The motor of an engine is rotating about its axis with an angular velocity of 100 rpm. It comes to rest in 15 s after being switched off. Assuming constant angular deceleration, calculate the number of revolution made by it before coming to rest.

A. 12.5

B. 40

C. 32.6

D. 15.6

**Answer: A**



[Watch Video Solution](#)

7. In case of a uniform circular motion, velocity and acceleration are

- A. perpendicular
- B. in same direction
- C. in opposite direction
- D. not related to each other

**Answer: A**



[Watch Video Solution](#)

8. A particle moves with constant speed  $v$  along a circular path of radius  $r$  and completes the circle in time  $T$ . The acceleration of the particle is

A.  $\frac{2\pi v}{T}$

B.  $\frac{2\pi r}{T}$

C.  $\frac{2\pi r^2}{T}$

D.  $\frac{2\pi v^2}{T}$

**Answer: A**



**Watch Video Solution**

9. A body is moving in a circular path with acceleration  $a$ . If its speed gets doubled, find the ratio of centripetal acceleration after and before the speed is changed

A. 1:4

B. 1:2

C. 2:1

D. 4:1

**Answer: D**



**Watch Video Solution**

**10.** The circular orbit of two satellites have radii  $r_1$  and  $r_2$  respectively ( $r_1 < r_2$ ). If angular velocities of satellites are same, then their centripetal accelerations are related as

A.  $a_1 > a_2$

B.  $a_1 = a_2$

C.  $a_1 < a_2$

D. Data insufficient

**Answer: C**



**Watch Video Solution**

11. A particle is moving on a circular track of radius 30 cm with a constant speed of  $6ms^{-1}$ . Its acceleration is

A. zero

B.  $120ms^{-2}$

C.  $1.2ms^{-2}$

D.  $36ms^{-2}$

**Answer: B**



[Watch Video Solution](#)

12. A particle moves along a circle of radius  $\left(\frac{20}{\pi}\right)$  m with constant tangential acceleration. If the velocity of the particle is 80 m/s at the end of the second revolution after motion has begun, the tangential acceleration is :-

A. 1.6

B. 4

C. 15.6

D. 31.2

**Answer: D**



[Watch Video Solution](#)

13. If  $a_r$  and  $a_t$  represent radial and tangential accelerations, the motion of a particle will be uniformly circular if

A.  $a_f = 0, a_t = 0$

B.  $a_f = 0, a_t \neq 0$

C.  $a_f \neq 0, a_t \neq 0$

D. None of these

**Answer: C**



[Watch Video Solution](#)

14. A car has linear velocity  $v$  on a circular road of radius  $r$ . If  $r$  is increasing its speed at the rate of  $a \text{ ms}^{-2}$ , then the resultant acceleration will be

A.  $\sqrt{\frac{v^2}{a^2} + r^2}$

B.  $\sqrt{\frac{v^2}{r} + a}$

C.  $\sqrt{\frac{v^4}{r^2} + a^2}$

D.  $\left(\frac{v^2}{r} + a\right)$

**Answer: C**



**Watch Video Solution**

15. A point starts from rest and moves along a circular path with a constant tangential acceleration. After one rotation, the ratio of its radial acceleration to its tangential acceleration will be equal to

A. 1



B.  $2\pi$

C.  $\frac{1}{2}\pi$

D.  $4\pi$

**Answer: D**



**Watch Video Solution**

**16.** A particle is moving on a circular path of 10 m radius. At any instant of time, its speed is  $5ms^{-1}$  and the speed is increasing at a rate of  $2ms^{-2}$

The magnitude of net acceleration at this instant is

A.  $3.2ms^{-2}$

B.  $2ms^{-2}$

C.  $1.2ms^{-2}$

D.  $4.3ms^{-2}$

**Answer: A**

[Watch Video Solution](#)

17. A body is moving on a circle of radius 80 m with a speed 20 m/s which is decreasing at the rate  $5 \text{ ms}^{-2}$  at an instant. The angle made by its acceleration with its velocity is

A.  $1.25m$

B.  $12.5m$

C.  $25m$

D.  $2.5m$

**Answer: A**

[Watch Video Solution](#)

18. A particle moves in a circular path of radius R with an angular velocity  $\omega = a - bt$ , where a and b are positive constants and t is time. The magnitude of the acceleration of the particle after time  $\frac{2a}{b}$  is

A.  $\frac{a}{R}$

B.  $a^2R$

C.  $R(a^2 + b)$

D.  $R\sqrt{a^4 + b^2}$

**Answer: D**



**Watch Video Solution**

19. a particle moves on a circular path of radius 8 m. distance traveled by the particle in time  $t$  is given by the equation  $s = \frac{2}{3}t^3$ . Find its speed when tangential and normal accelerations have equal magnitude.

A. 1:1

B. 1:2

C. 2:1

D. 3:1

**Answer: B**



[Watch Video Solution](#)

20. A body is moving on a circle of radius 80 m with a speed 20 m/s which is decreasing at the rate  $5 \text{ ms}^{-2}$  at an instant. The angle made by its acceleration with its velocity is

A.  $45^\circ$

B.  $90^\circ$

C.  $135^\circ$

D.  $0^\circ$

**Answer: C**



[Watch Video Solution](#)

21. A particle of mass 2 kg is moving along a circular path of radius 1 m. If its angular speed is  $2\pi \text{ rad s}^{-1}$ , the centripetal force on it is

A.  $4\pi N$

B.  $8\pi N$

C.  $4\pi^4 N$

D.  $8\pi^2 N$

**Answer: D**



[Watch Video Solution](#)

22. Two particles of equal masses are revolving in circular paths of radii  $r_1$  and  $r_2$  respectively with the same speed. The ratio of their centripetal force is

A.  $\frac{r_2}{r_1}$

B.  $\sqrt{\frac{r_2}{r_1}}$

C.  $\left(\frac{r_1}{r_2}\right)^2$

D.  $\left(\frac{r_2}{r_1}\right)^2$

**Answer: A**



**Watch Video Solution**

**23.** A particle of mass  $m$  is executing uniform circular motion on a path of radius  $r$ . If  $p$  is the magnitude of its linear momentum, then the radial force acting on the particle is

A.  $pmr$

B.  $\frac{rm}{p}$

C.  $\frac{mp^2}{r}$

D.  $\frac{p^2}{rm}$

**Answer: D**



**Watch Video Solution**

24. A stone of mass of 16 kg is attached to a string 144 m long and is whirled in a horizontal circle. The maximum tension the string can withstand is 16 Newton . The maximum velocity of revolution that can be given to the stone without breaking it, will be

A.  $20ms^{-1}$

B.  $16ms^{-1}$

C.  $14ms^{-1}$

D.  $12ms^{-1}$

**Answer: D**



[Watch Video Solution](#)

25. It mass, speed and radius of the circle of a particle moving uniformly in a circular path are all increased by 50 % , the necessary force required

to maintain the body moving in the circular path will have to be increased by

A. 225 %

B. 125 %

C. 150 %

D. 100 %

**Answer: B**



[Watch Video Solution](#)

**26.** A string of length 0.1 m cannot bear a tension more than 100 N. It is tied to a body of mass 100 g and rotated in a horizontal circle. The maximum angular velocity can be

A.  $100\text{rad s}^{-1}$

B.  $1000\text{rad s}^{-1}$

C.  $10000\text{s}^{-1}$



D.  $0.1 \text{ rad s}^{-1}$

**Answer: A**



**Watch Video Solution**

27. A mass 2 kg is whirled in a horizontal circle by means of a string at an initial speed of 5 revolutions per minute . Keeping the radius constant the tension in the string is doubled. The new speed is nearly

A.  $\frac{5}{\sqrt{2}} \text{ rpm}$

B. 10 rpm

C.  $10\sqrt{2} \text{ rpm}$

D.  $5\sqrt{2} \text{ rpm}$

**Answer: D**



**Watch Video Solution**

28. A mass of 100 gm is tied to one end of a string 2 m long. The body is revolving in a horizontal circle making a maximum of 200 revolutions per min. The other end of the string is fixed at the centre of the circle of revolution. The maximum tension that the string can bear is (approximately)

A. 8.76 N

B. 8.94 N

C. 89.42 N

D. 87.64 N

**Answer: D**



[Watch Video Solution](#)

29. A car is taking turn on a circular path of radius  $R$ . If the coefficient of friction between the tyres and road is  $\mu$ , the maximum velocity for no slipping is

A.  $\mu Rg$

B.  $2\mu Rg$

C.  $(\mu Rg)^{1/2}$

D.  $(2\mu Rg)^{1/2}$

**Answer: C**



**Watch Video Solution**

**30.** A car is moving in a circular horizontal track of radius 10 m with a constant speed of 10 m/s. A plumb bob is suspended from the roof of the car by a light rigid rod. The angle made by the rod with the vertical is

$(g = 10m/s^2)$

A. zero

B.  $30^\circ$

C.  $45^\circ$

D.  $60^\circ$

**Answer: C**



**Watch Video Solution**

**31.** The radius of the curved road on a national highway is  $R$ . The width of the road is  $b$ . The outer edge of the road is raised by  $h$  with respect to the inner edge so that a car with velocity  $v$  can pass safe over it. The value of  $h$  is

A.  $\frac{v^2 b}{Rg}$

B.  $\frac{v}{Rgb}$

C.  $\frac{v^2 R}{bg}$

D.  $\frac{v^2 b}{R}$

**Answer: A**



**Watch Video Solution**

32. A motor cyclist moving with a velocity of 72 km/hour on a flat road takes a turn on the road at a point where the radius of curvature of the road is 20 meters . The acceleration due to gravity is  $10m/sec^2$ . In order to avoid skidding, he must not bend with respect to the vertical plane by an angle greater than

A.  $\theta = \tan^{-1}(6)$

B.  $\theta = \tan^{-1}(2)$

C.  $\theta = \tan^{-1}(25.92)$

D.  $\theta = \tan^{-1}(4)$

**Answer: B**



[Watch Video Solution](#)

33. A car of mass  $1000kg$  negotiates a banked curve of radius  $90m$  on a frictionless road. If the banking angle is  $45^\circ$  the speed of the car is:

A.  $20ms^{-1}$

B.  $30ms^{-1}$

C.  $5ms^{-1}$

D.  $10ms^{-1}$

**Answer: B**



**Watch Video Solution**

**34.** Keeping the angle of banking, if the radius of curvature is made four times, the percentage increase in the maximum speed with which a vehicle can travel on a circular road is

A. 25 %

B. 50 %

C. 75 %

D. 100 %

**Answer: D**



**Watch Video Solution**

35. A person wants to drive on the vertical surface of a large cylindrical wooden 'well' commonly known as 'death well' in a circus. The radius of the well is  $R$  and the coefficient of friction between the tyres of the motorcycle and the wall of the well is  $\mu$ . The minimum speed the motorcyclist must have in order to prevent slipping should be -

A.  $\sqrt{\frac{Rg}{(\mu)_s}}$

B.  $\sqrt{\frac{\mu_s}{Rg}}$

C.  $\sqrt{\frac{\mu_s g}{R}}$

D.  $\sqrt{\frac{R}{\mu_s g}}$

**Answer: A**



**Watch Video Solution**

36. A motorcyclist wants to drive on the vertical surface of wooden 'well' of radius 5 m, with a minimum speed of  $5\sqrt{5}ms^{-1}$ . The minimum value of coefficient of friction between the tyres and the well must be (take,  $g = 10ms^{-2}$ )

- A. 0.10
- B. 0.20
- C. 0.30
- D. 0.40

**Answer: D**



[Watch Video Solution](#)

37. A block of mass  $m$  at the end of a string is whirled round in a vertical circle of radius  $R$ . The critical speed of the block at top of its swing below which the string would slacken before the block reaches the bottom is?



A.  $\sqrt{5Rg}$

B.  $\sqrt{3Rg}$

C.  $\sqrt{2Rg}$

D.  $\sqrt{Rg}$

**Answer: D**



**Watch Video Solution**

**38.** A stone of mass of 1 kg is tied to the end of a string 1 m long. It is whirled in a vertical circle. The velocity of the stone at the bottom of the circle is just sufficient to take it to the top of circle without slackening of the string. What is the tension in the string at the top of the circle? (Take,  $g = 10 \text{ m s}^{-2}$ )

A. zero

B. 1 N

C.  $\sqrt{10} \text{ N}$

D. 10 N

Answer: A

 Watch Video Solution

39. A stone is attached to one end of a string and rotated in vertical circle. If string breaks at the position of maximum tension, will break at

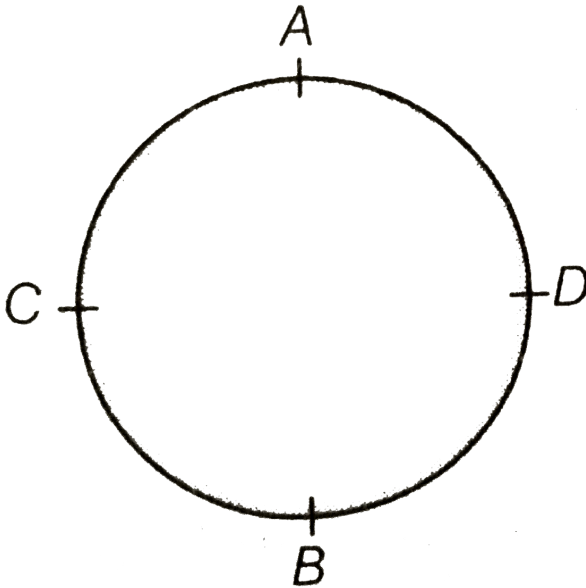

A. A

B. B

C. C

D. D

**Answer: A**



[Watch Video Solution](#)

40. A particle is moving in a vertical circle with constant speed. The tensions in the string when passing through two positions at angles  $30^\circ$  and  $60^\circ$  from vertical (lowest position) are  $T_1$  and  $T_2$  respectively. Then

A.  $T_1 = T_2$

B.  $T_2 > T_1$

C.  $T_1 > T_2$

D. Data insufficient

**Answer: C**



[Watch Video Solution](#)

41. A particle of mass  $m$  is being circulated on a vertical circle of radius  $r$ .

If the speed of particle at the highest point be  $v$ , then

A.  $mg = \frac{mv^2}{r}$

B.  $mg > \frac{mv^2}{r}$

C.  $mg \leq \frac{mv^2}{r}$

D.  $mg \geq \frac{mv^2}{r}$

Answer: D



Watch Video Solution

42. An isolated charge  $q_1$  of mass  $m$  is suspended freely by a thread of length  $l$ . Another charge  $q_2$  is brought near it ( $r > l$ ). When  $q_1$  is in

equilibrium tension in thread will be

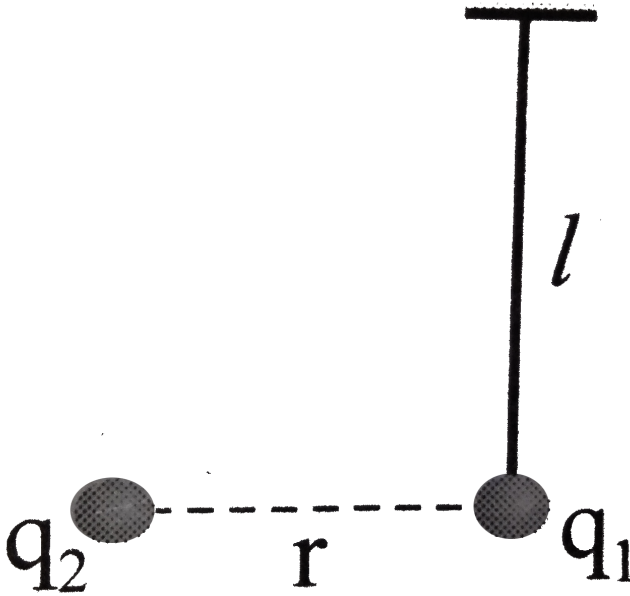

- A.  $mg$
- B.  $2 mg$
- C.  $3 mg$
- D.  $6 mg$

**Answer: C**



**Watch Video Solution**

43. A child is swinging a swing. Minimum and maximum heights fo swing from the earth's surface are 0.75 m and 2 m respectively. The maximum velocity of this swing is

A.  $5ms^{-1}$

B.  $10ms^{-1}$

C.  $15ms^{-1}$

D.  $20ms^{-1}$

**Answer: A**



[Watch Video Solution](#)

44. A national roadway bridge over a canal is in the form of an arc of a circle of radius 49 m. What is the maximum speed with which a car can move without leaving the ground at the highest point? (Take,  $g = 9.8ms^{-2}$ )

A.  $19.6ms^{-1}$

B.  $40\text{ms}^{-1}$

C.  $22\text{ms}^{-1}$

D. None of the above

Answer: C

 Watch Video Solution

45. A frictionless track ABCDE ends in a circular loop of radius  $R$ . A body slides down the track from point A which is at height  $h = 5\text{cm}$ . Maximum value of  $R$  for a body to complete the loop successfully is

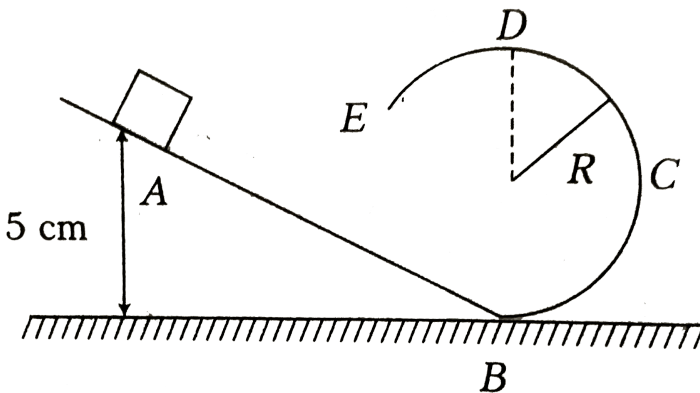

A. 2 cm

B.  $\frac{10}{3}$  cm

C.  $\frac{15}{4}$  cm

D.  $\frac{18}{3}$  cm

**Answer: A**



**Watch Video Solution**

## Taking it together

1. For a particle performing uniform circular motion, choose the incorrect statement from the following.

- A. The particle moves with constant speed
- B. The acceleration is always normal to the velocity
- C. The particle moves with uniform acceleration
- D. The particle moves with variable velocity



**Answer: C**



[Watch Video Solution](#)

2. A stone is tied with a string and is rotated in a circle horizontally. When the string suddenly breaks, the stone will move

- A. tangential to the motion
- B. away from the centre
- C. towards the centre
- D. none of these

**Answer: A**



[Watch Video Solution](#)

3. A particle moving along a circular path due to a centripetal force having constant magnitude is an example of motion with :

- A. constant speed and velocity
- B. variable speed and variable velocity
- C. variable speed and constant velocity
- D. constant speed and variable velocity

**Answer: D**



[Watch Video Solution](#)

4. A particle moving on a circular path makes 600 rpm. In how much time it will complete one revolution?

- A. 0.2s
- B. 0.1s
- C. 0.4s
- D. 0.3s

**Answer: B**

 [Watch Video Solution](#)

5. A wheel having moment of inertia  $2\text{kgm}^{-2}$  about its axis, rotates at 50 rpm about this axis. The angular retardation that can stop the wheel in one minute is

A.  $\frac{\pi}{36}\text{rad s}^{-2}$

B.  $\frac{\pi}{18}\text{rad s}^{-2}$

C.  $\frac{\pi}{72}\text{rad s}^{-2}$

D.  $\frac{\pi}{9}\text{rad s}^{-2}$

**Answer: A**

 [Watch Video Solution](#)

6. The speed of a particle moving in a circle is increasing. The dot product of its acceleration and velocity is

A. negative

B. zero

C. positive

D. may be positive or negative

**Answer: C**



**Watch Video Solution**

7. A particle moves with constant angular velocity in a circle. During the motion its

A. energy is conserved

B. momentum is conserved

C. energy and momentum both are conserved

D. None of the above

**Answer: A**

 [Watch Video Solution](#)

8. An object is moving in a circle of radius 100 m with a constant speed of  $31.4\text{ m/s}$ . What is its average speed for one complete revolution

A. Zero

B.  $31.4\text{ m s}^{-1}$

C.  $3.14\text{ m s}^{-1}$

D.  $\sqrt{2} \times 31.4\text{ m s}^{-1}$

**Answer: B**

 [Watch Video Solution](#)

9. A bucket full of water is rotated in a vertical circle of radius  $R$ . If the water does not split out, the speed of the bucket at topmost point will be

A.  $\sqrt{Rg}$

B.  $\sqrt{5gR}$

C.  $\sqrt{2Rg}$

D.  $\sqrt{\frac{R}{g}}$

**Answer: A**

 [Watch Video Solution](#)

**10.** A car of mass  $m$  moving over a convex bridge of radius  $r$  .Find the normal reaction acting on car when it is at highest point the bridge.

A.  $Mg + \frac{Mv^2}{r}$

B.  $\frac{Mv^2}{r}$

C.  $Mg - \frac{Mv^2}{r}$

D. None of these

**Answer: C**

 [Watch Video Solution](#)

11. In  $1.0\text{s}$ , a particle goes from point  $A$  to point  $B$ , moving in a semicircle of radius  $1.0\text{m}$  (see figure). The magnitude of the average velocity

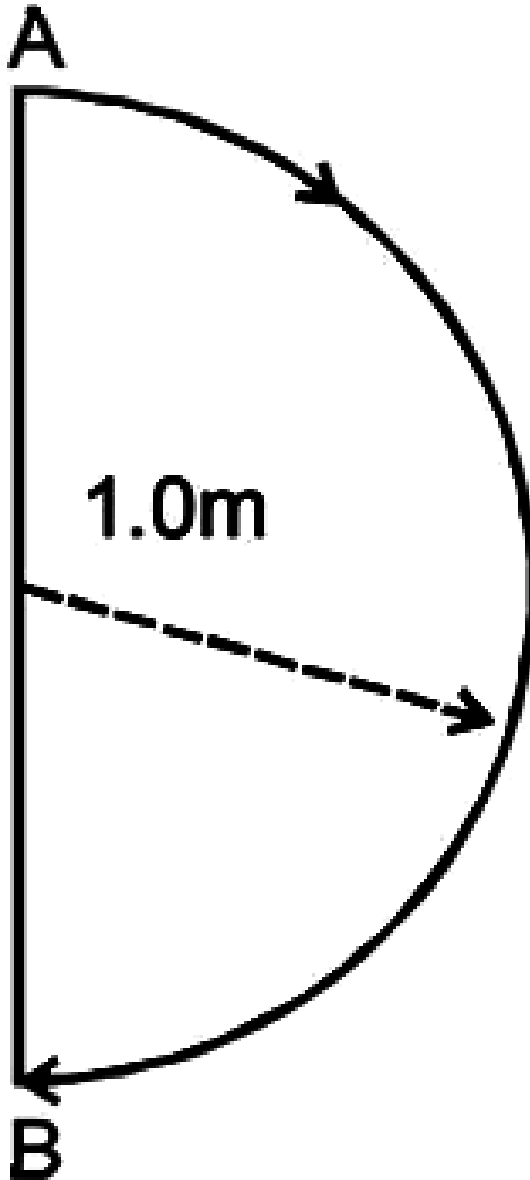

A.  $3.14ms^{-1}$

B.  $2ms^{-1}$

C.  $1ms^{-1}$

D. zero

**Answer: B**



**Watch Video Solution**

**12.** A fan makes 2400 rpm. If after it is switched off, it comes to rest in 10 s, then find the number of times it will rotate before it comes to rest after it is switched off.

A. 400

B. 100

C. 200

D. 50



**Answer: C**



**Watch Video Solution**

**13.** The distance between the rails of the track is 1.67 m. How much the outer rail be elevated for curve of 0.5km radius, so that a train moving with speed  $54kmh^{-1}$  can take safe turn on track.

A. 80 mm

B. 75 mm

C. 60 mm

D. 75 mm

**Answer: B**



**Watch Video Solution**

14. A car is moving on a circular path and takes a turn. If  $R_1$  and  $R_2$  be the reactions on the inner and outer wheels, respectively, then

A.  $R_1 = R_2$

B.  $R_1 < R_2$

C.  $R_1 > R_2$

D.  $R_1 \geq R_2$

**Answer: B**



[Watch Video Solution](#)

15. An unbanked curve has a radius of 60m. The maximum speed at which a car can make a turn if the coefficient of static friction is 0.75 , is

A.  $2.1ms^{-1}$

B.  $14ms^{-1}$

C.  $21ms^{-1}$

D.  $7ms^{-1}$

**Answer: C**



**Watch Video Solution**

**16.** A particle is moving in a circle with uniform speed  $v$ . In moving from a point to another diametrically opposite point

- A. the momentum change by  $mv$
- B. the momentum changes by  $2mv$
- C. the kinetic energy changes by  $\left(\frac{1}{2}\right)mv^2$
- D. the kinetic energy changes by  $mv^2$

**Answer: B**



**Watch Video Solution**

17. A motor cyclist riding at  $36\text{kmh}^{-1}$  has turn a corner. Find the least radius of the curve, he should follow for safe travelling, if the coefficient of friction between the tyres and the road is 0.2.

- A. 10 m
- B. 25 m
- C. 50 m
- D. 100 m

**Answer: C**



**Watch Video Solution**

18. A circular curve of a highway is designed for traffic moving at 72 km/h. if the radius of the curved path is 100 m, the correct angle of banking of the road should be given by:

A.  $\tan^{-1}\left(\frac{2}{5}\right)$

B.  $\tan^{-1}\left(\frac{3}{5}\right)$

C.  $\tan^{-1}\left(\frac{1}{5}\right)$

D.  $\tan^{-1}\left(\frac{1}{4}\right)$

**Answer: A**



**Watch Video Solution**

19. A particle of mass  $m$  is executing uniform circular motion on a path of radius  $r$ . If  $p$  is the magnitude of its linear momentum. The radial force acting on the particles is

A.  $\frac{L^2}{mr}$

B.  $\frac{L^2}{mr^2}$

C.  $\frac{L^2}{mr^3}$

D.  $\frac{L}{mr^2}$

**Answer: C**



20. A conical pendulum of length  $L$  makes an angle  $\theta$  with the vertical. The time period will be

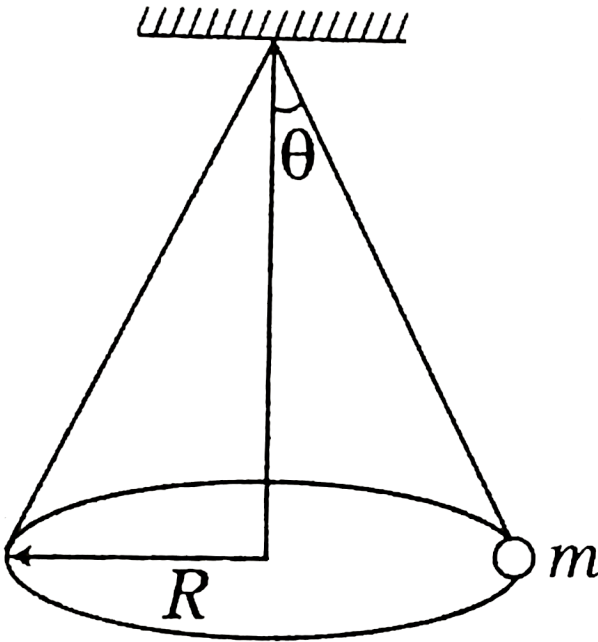

A.  $2\pi\sqrt{\frac{l \cos \theta}{g}}$

B.  $2\pi\sqrt{\frac{L}{g \cos \theta}}$

C.  $2\pi\sqrt{\frac{L \tan \theta}{\gamma}}$

$$D. 2\pi \sqrt{\frac{L}{g \tan \theta}}$$

**Answer: A**



**Watch Video Solution**

21. A body of mass 1 kg is moving in a vertical circular path of radius 1 m. The difference between the kinetic energies at its highest and lowest position is

A. 20 J

B. 10 J

C.  $4\sqrt{5}$  J

D.  $10(\sqrt{5} - 1)$  J

**Answer: A**



**Watch Video Solution**

22. A particle is moving along a circular path of radius 5 m with a uniform speed  $5ms^{-1}$ . What will be the average acceleration when the particle completes half revolution?

A. Zero

B.  $10ms^{-2}$

C.  $10\pi ms^{-2}$

D.  $\frac{10}{\pi}ms^{-2}$

**Answer: D**



**Watch Video Solution**

23. Keeping the banking angle same, to increase the maximum speed with which a vehicle can travel on the curved road by 10%, the radius of curvature of the road has to be changed from 20 m to

A.  $86.4km\ h^{-1}$

B.  $43.2km\ h^{-1}$



C.  $21.6\text{km h}^{-1}$

D.  $30.4\text{km h}^{-1}$

**Answer: C**



**Watch Video Solution**

**24.** A motor cyclist moving with a velocity of  $72\text{kmh}^{-1}$  on a flat road takes a turn on the road at a point where the radius of curvature of the road is  $20\text{km}$ . The acceleration due to gravity is  $10\text{ms}^{-2}$ . IN order to avoid skidding , he must not bend with respect to the vertical plane by an angle greater then

A.  $\theta = \tan^{-1}(4)$

B.  $\theta = 45^\circ$

C.  $\theta = \tan^{-1}(2)$

D.  $\theta = \tan^{-1}(6)$

**Answer: A**



[Watch Video Solution](#)

25. A train has to negotiate a curve of radius 2000 m. By how much should the outer rail be raised with respect to inner rail for a speed of  $72\text{kmh}^{-1}$ . The distance between the rails is 1 m.

A. 4.4 cm

B. 9 cm

C. 8.8 cm

D. 3.3 cm

**Answer: C**



[Watch Video Solution](#)

26. A car wheel is rotated to uniform angular acceleration about its axis. Initially its angular velocity is zero. It rotates through an angle  $\theta_1$  in the

first 2 s. In the next 2 s, it rotates through an additional angle  $\theta_2$ , the ratio of  $\frac{\theta_2}{\theta_1}$  is

- A. 1
- B. 2
- C. 3
- D. 4

**Answer: C**



[Watch Video Solution](#)

27. A pendulum bob on a 2 m string is displaced  $60^\circ$  from the vertical and then released. What is the speed of the bob as it passes through the lowest point in its path

- A.  $\sqrt{2}ms^{-1}$
- B.  $\sqrt{9.8}ms^{-1}$
- C.  $4.43ms^{-1}$

D.  $\frac{1}{\sqrt{2}}ms^{-1}$

**Answer: C**



**Watch Video Solution**

**28.** The bob of a 0.2 m pendulum describes an arc of circle in a vertical plane. If the tension in the cord is  $\sqrt{3}$  times the weight of the bob when the cord makes an angle  $30^\circ$  with the vertical, the acceleration of the bob in that position is  $g/n$ . Find value of  $n$ .

A.  $g$

B.  $\frac{g}{2}$

C.  $\frac{\sqrt{3}g}{2}$

D.  $\frac{g}{4}$

**Answer: A**



**Watch Video Solution**

29. In a typical projectile motion, tangential acceleration at the topmost point P of the trajectory is

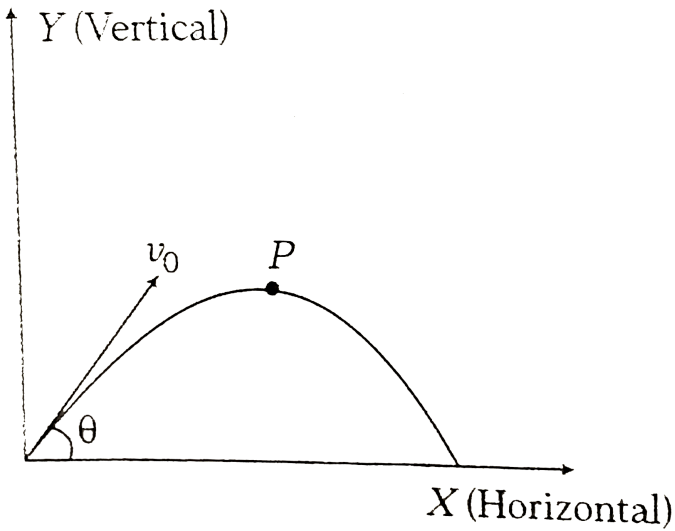

- A.  $g$
- B.  $g \cos \theta$
- C. 0
- D. None of these

**Answer: C**

 [Watch Video Solution](#)

30. A car runs around a curve of radius 10m at a constant speed of  $10ms^{-1}$ . Consider the time interval for which car covers a curve of  $120^\circ$  are:-

- A. resultant change in velocity of jeep is  $60ms^{-1}$
- B. instantaneous acceleration of jeep is  $12ms^{-2}$
- C. average acceleration of of jeep is approximately  $11.5ms^{-2}$
- D. All are correct

**Answer: D**



[Watch Video Solution](#)

31. A coin placed on a rotating turntable just slips if it is placed at a distance of 4 cm from the centre. If the angular velocity of the turntable is doubled, it will just slip at a distance of

- A. 27 cm

B. 9 cm

C. 3 cm

D. 1 cm

Answer: D

 Watch Video Solution

32. As shown in the figure, a disc of mass  $m$  is rolling without slipping a angular velocity  $\omega$ . When it crosses point  $B$  disc will be in :

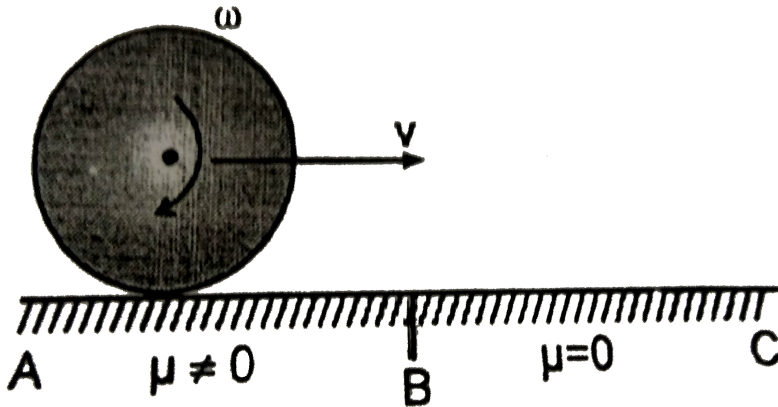

A. zero

B.  $R\omega \sin\left(\frac{\theta}{2}\right)$

C.  $2R\omega \sin\left(\frac{\theta}{2}\right)$

D.  $\sqrt{3}R\omega \sin\left(\frac{\theta}{2}\right)$

**Answer: C**



**Watch Video Solution**

**33.** If the linear momentum of a body is increased by 50%, then the kinetic energy of that increases by :

A.  $2.5ms^{-2}$ ,  $7.5ms^{-2}$

B.  $7.5ms^{-2}$ ,  $22.5ms^{-2}$

C.  $5ms^{-2}$ ,  $45ms^{-2}$

D.  $2.5ms^{-2}$ ,  $22.5ms^{-2}$

**Answer: D**



**Watch Video Solution**



34. An automobile enters a turn whose radius is  $R$ . The road is banked at angle  $\theta$ . Friction is negligible between wheels of the automobile and road, Mass of automobile is  $m$  and speed is  $v$ . Select the correct alternative.

A.  $\sqrt{\frac{rg}{2}}$

B.  $\frac{\sqrt{rg}}{2}$

C.  $\sqrt{rg}$

D. zero

**Answer: D**



[Watch Video Solution](#)

35. A mass is attached to the end of a string of length  $l$  which is tied to a fixed point  $O$ . The mass is released from the initial horizontal position of the string. Below the point  $O$  at what minimum distance a peg  $P$  should be fixed so that the mass turns about  $P$  and can describe a complete circle in the vertical plane?

A.  $\left(\frac{3}{5}\right)l$

B.  $\left(\frac{2}{5}\right)l$

C.  $\frac{l}{3}$

D.  $\frac{2l}{3}$

**Answer: A**



**Watch Video Solution**

**36.** A stone is rotated in a vertical circle. Speed at bottommost point is  $\sqrt{8gR}$ , where R is the radius of circle. The ratio of tension at the top and the bottom is

A. 1:2

B. 1:3

C. 2:3

D. 1:4

**Answer: B**



[Watch Video Solution](#)

**37.** The string of a pendulum is horizontal. The mass of the bob is  $m$ . Now the string is released. The tension in the string in the lowest position is -

A.  $mg$

B.  $2 mg$

C.  $3 mg$

D.  $4 mg$

**Answer: C**



[Watch Video Solution](#)

**38.** A body is moving in a vertical circle of radius  $r$  such that the string is just taut at its highest point. The speed of the particle when the string is

horizontal is

A.  $\sqrt{gr}$

B.  $\sqrt{2gR}$

C.  $\sqrt{3gr}$

D.  $\sqrt{4gR}$

**Answer: C**



**Watch Video Solution**

**39.** A small ball is pushed from a height  $h$  along a smooth hemispherical bowl of radius  $R$ . With what speed should the ball be pushed so that it just reaches the top of the opposite end of the bowl?

A.  $\sqrt{2gh}$

B.  $\sqrt{2g(R + h)}$

C.  $\sqrt{2g(R - h)}$

D. None of these

**Answer: C**



[Watch Video Solution](#)

40. A 50 kg girl is swinging on a swing from rest. Then, the power delivered when moving with a velocity of  $2ms^{-1}$  upwards in a direction making an angle  $60^\circ$  with the vertical is

A.  $490\sqrt{3}W$

B. 490 W

C.  $490\sqrt{2}W$

D. 245 W

**Answer: C**



[Watch Video Solution](#)

41. A simple pendulum of length  $l$  has a maximum angular displacement  $\theta$ .

The maximum kinetic energy of the bob of mass  $m$  will be

A.  $mgl(1 - \cos \theta)$

B.  $mgl \cos \theta$

C.  $mgl \sin \theta$

D. None of these

**Answer: A**

 [Watch Video Solution](#)

42. Toy cart tied to the end of an unstretched string of length  $a$ , when revolved moves in a horizontal circle of radius  $2a$  with a time period  $T$ .

Now the toy cart is speeded up until it moves in a horizontal circle of radius  $3a$  with a period  $T$ . If Hooke's law ( $F=kx$ ) holds, then

A.  $T' = \sqrt{\frac{3}{2}}T$

B.  $T' = \left(\frac{\sqrt{3}}{2}\right)T$

C.  $T' = \left(\frac{3}{2}\right)T$

D.  $T' = T$

**Answer: B**

 [Watch Video Solution](#)

43. A sphere is suspended by a thread of length  $l$ . What minimum horizontal velocity has to be imparted to the ball for it to reach the height of the suspension?

A.  $\sqrt{5gl}$

B.  $2gl$

C.  $\sqrt{gl}$

D.  $\sqrt{2gl}$

**Answer: D**

 [Watch Video Solution](#)

44. A cyclist starts from the center  $O$  of a circular park of radius  $1\text{km}$ , reaches the edge  $P$  of the park, then cycles along the  $PQ$  circumference and returns to the center along  $OQ$  as shown in fig. If the round trip taken ten minute, the (a) net displacement, (b) average velocity and (c) average speed of the cyclists (in kilometer per hour) is

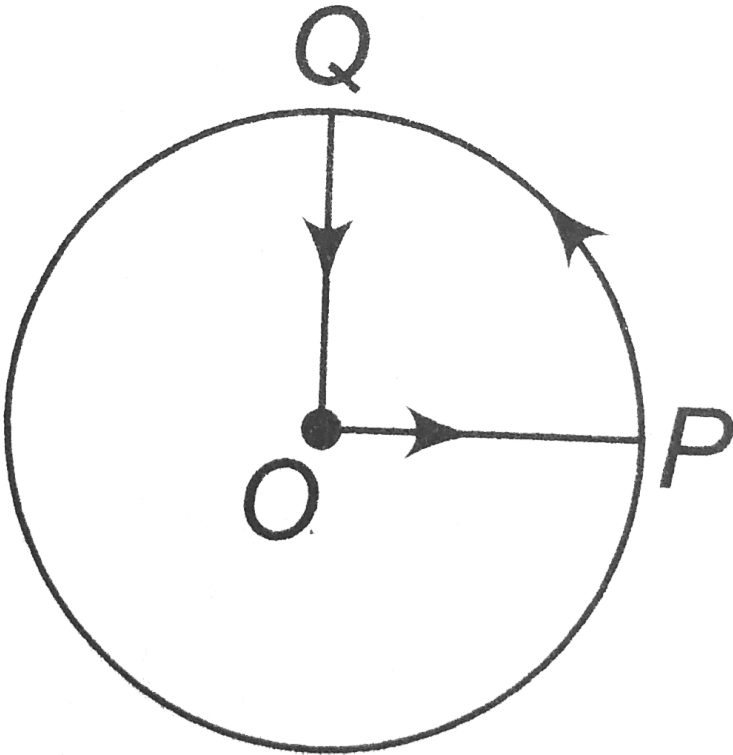

A.  $0, 1$

B.  $\frac{\pi + 4}{2}, 4$



C. 21.4,  $\frac{\pi + 4}{2}$

D. 0, 21.4

**Answer: D**

 [Watch Video Solution](#)

45. Three particles A, B and C move in a circle of radius  $r = \frac{1}{\pi}$  m, in anti-clockwise direction with speed  $1\text{ms}^{-1}$ ,  $2.5\text{ms}^{-1}$  and  $2\text{ms}^{-1}$  respectively. The initial position of A, B and C are as shown in figure.

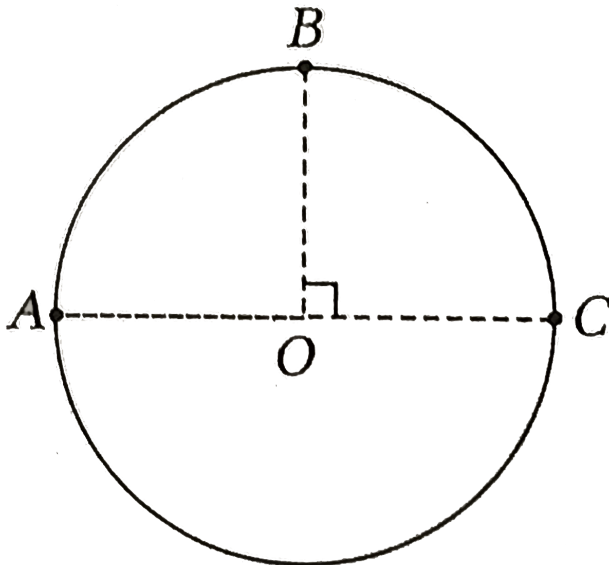

The ratio of distance travelled by B and C by the instant A, B and C meet for the first time is

A. 3:2

B. 5:4

C. 3:5

D. 3:7

**Answer: B**



[Watch Video Solution](#)

**46.** Two particles A and B start at the origin O and travel in opposite directions along the circular path at constant speeds  $v_A = 0.7ms^{-1}$  and  $v_B = 1.0ms^{-1}$ , respectively.

Determine the time when they collide and the magnitude of the acceleration of B just before this happens.



A.  $14.35, 0.45ms^{-2}$

B.  $1.25, 0.2ms^{-2}$

C.  $11.25, 0.5ms^{-2}$

D.  $14.55, 0.3ms^{-2}$

**Answer: A**

 [Watch Video Solution](#)

**47.** A boy whirls a stone of small mass in a horizontal circle of radius  $1.5m$  and at height  $2.9m$  above level ground. The string breaks and the stone flies off horizontally and strikes the ground after travelling a horizontal distance of  $10m$ . What is the magnitude of the centripetal acceleration of the stone while in circular motion ?

A.  $150 ms^{-2}$

B.  $140 ms^{-2}$

C.  $81.4ms^{-2}$

D.  $163 \text{ m.s}^{-2}$

**Answer: C**

 [Watch Video Solution](#)

**48.** A stone tied to a string of length  $L$  is whirled in a vertical circle with the other end of the string at the centre. At a certain instant of time the stone is at lowest position and has a speed  $u$ . Find the magnitude of the change in its velocity as it reaches a position, where the string is horizontal.

A.  $\sqrt{2(u^2 - gl)}$

B.  $\sqrt{u^2 - gl}$

C.  $u - \sqrt{u^2 - 2gl}$

D.  $\sqrt{2gl}$

**Answer: A**

 [Watch Video Solution](#)

49. A ball suspended by a thread swings in a vertical plane so that its acceleration in the extreme position and lowest position are equal. The angle  $\theta$  of thread deflection in the extreme position will be

A.  $\tan^{-1}(2)$

B.  $\tan^{-1}(\sqrt{2})$

C.  $\tan^{-1}\left(\frac{1}{2}\right)$

D.  $2 \tan^{-1}\left(\frac{1}{2}\right)$

**Answer: D**



**Watch Video Solution**

50. A particle of mass 200 g , is whirled into a vertical circle of radius 80 cm using a massless string. The speed of the particle when the string makes an angle of  $60^\circ$  with the vertical line is  $1.5 \text{ms}^{-1}$ . The tension in the string at this position is

A. 2 mg

B. mg

C. 3 mg

D.  $\sqrt{3}mg$

**Answer: A**



[Watch Video Solution](#)

51. A simple pendulum suspended from the roof of a lift oscillates with frequency  $\nu$  when the lift is at rest. If the lift falls freely under gravity, its frequency of oscillation becomes

A.  $30^\circ$

B.  $45^\circ$

C.  $60^\circ$

D.  $90^\circ$

**Answer: D**



**Watch Video Solution**

52. A stone of 1 kg tied up with  $10/3$  m long string rotated in a vertical circle. If the ratio of maximum and minimum tension in string is 4 then speed of stone at highest point of circular path will be ( $g = 10ms^{-2}$ )

A.  $10ms^{-1}$

B.  $5\sqrt{2}ms^{-1}$

C.  $10\sqrt{3}ms^{-1}$

D.  $20ms^{-1}$

**Answer: A**



**Watch Video Solution**

53. A string of length  $l$  fixed at one end carries a mass  $m$  at the other end. The string makes  $\frac{2}{\pi} \text{ revs}^{-1}$  around the axis through the fixed end as shown in the figure, the tension in the string is

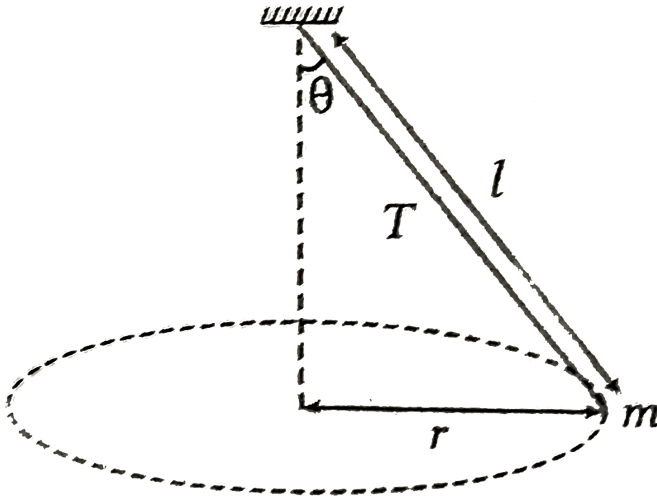

- A.  $16 \text{ ml}$
- B.  $4 \text{ ml}$
- C.  $8 \text{ ml}$
- D.  $2 \text{ ml}$

Answer: A



Watch Video Solution



54. A particle starts travelling on a circle with constant tangential acceleration. The angle between velocity vector and acceleration vector, at the moment when particle completes half the circular track. Is

A.  $\tan^{-1}(2\pi)$

B.  $\tan^{-1}(\pi)$

C.  $\tan^{-1}(3\pi)$

D. zero

**Answer: A**



Watch Video Solution

55. The weight of an object on the surface of the Earth is 40 N. Its weight at a height equal to the radius of the Earth is

A.  $\sqrt{2.5}m$

B. 1 m

C. 3 mg

D. 1.5 m

**Answer: A**



**Watch Video Solution**

**56.** A heavy particle is tied to the end A of a string of the length 1.6 m. Its other end O is fixed. It revolves as a conical pendulum with the string making  $60^\circ$  with the horizontal. Then,

A. its period of revolution is  $\frac{4\pi}{7} s$

B. the tension in the string is  $\frac{1}{\sqrt{3}}$  times the weight of the particle

C. the speed of the particle is  $2.8\sqrt{3}ms^{-1}$

D. the centripetal acceleration of the particle is  $\frac{9.8}{\sqrt{3}}ms^{-2}$

**Answer: D**

 [Watch Video Solution](#)

57. A pendulum bob has a speed of  $3ms^{-1}$  at its lowest position. The pendulum is 0.5 m long. The speed of the bob, when string makes an angle of  $60^\circ$  to the vertical is (take,  $g = 10ms^{-1}$ )

A.  $2ms^{-1}$

B.  $\frac{1}{2}ms^{-1}$

C.  $1ms^{-1}$

D.  $2.5ms^{-1}$

**Answer: A**

 [Watch Video Solution](#)

58. A block is released from rest at the top of an inclined plane which later curves into a circular track of radius  $r$  as shown in figure. Find the minimum height  $h$  from where it should be released so that it is able to

complete the circle.

ould be released so that it is a

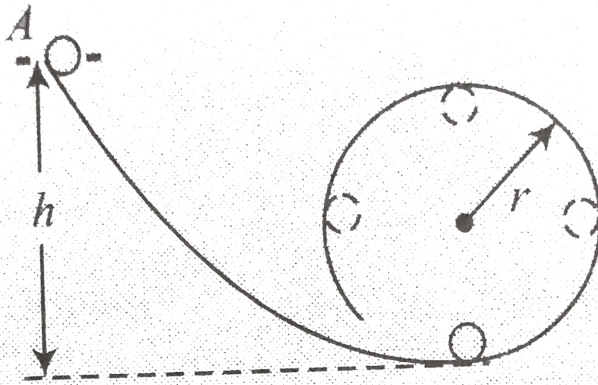

Fig. 8.150

1.

- A.  $r$
- B.  $2.5 r$
- C.  $1.5 r$
- D.  $0.5 r$

**Answer: B**



**Watch Video Solution**

59. The weight of an object on the surface of the Earth is 40 N. Its weight at a height equal to the radius of the Earth is

A.  $h = \frac{r}{2}$

B.  $h = \frac{r}{3}$

C.  $h = \frac{2r}{3}$

D.  $h = \frac{r}{4}$

**Answer: C**



**Watch Video Solution**

60. The maximum tension that an inextensible ring of radius 1 m and mass density  $0.1 \text{ kg m}^{-1}$  can bear is 40 N. The maximum angular velocity with which it can be rotated in a circular path is

A.  $20 \text{ rad s}^{-1}$

B.  $16 \text{ rad s}^{-1}$

C.  $18 \text{ rad s}^{-1}$

D.  $15 \text{ rad s}^{-1}$

**Answer: A**



**Watch Video Solution**

**61.** Two bodies of masses  $m$  and  $4m$  are attached to a light string as shown in figure. A body of mass  $m$  hanging from string is executing oscillations with angular amplitude  $60^\circ$ , while other body is at rest on a horizontal surface. The minimum coefficient of friction between mass  $4m$

and the horizontal surface is (here pulley is light and smooth)

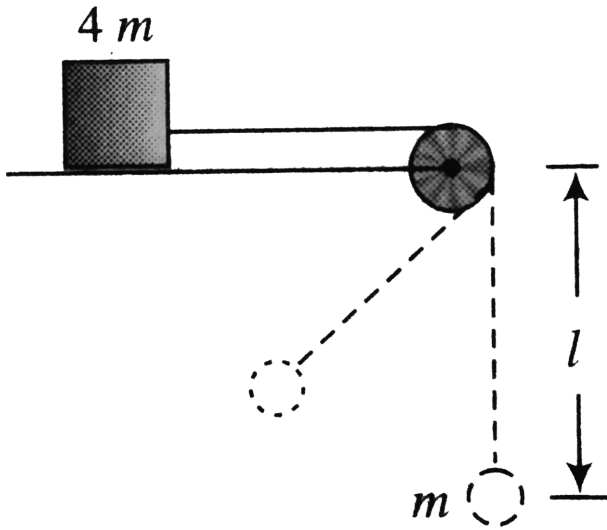

- A.  $\frac{1}{4}$
- B.  $\frac{1}{3}$
- C.  $\frac{1}{2}$
- D.  $\frac{2}{3}$

Answer: C



Watch Video Solution

62. A bullet of mass  $m$  moving with a horizontal velocity  $u$  strikes a stationary wooden block of mass  $M$  suspended by a string of length  $L = 50$  cm. The bullet emerges out of the block with speed  $\frac{u}{4}$ . If  $M = 6m$ , minimum value of  $u$  so that the block can complete the vertical circle (take,  $g = 10 \text{ m s}^{-2}$ )

A.  $10 \text{ m s}^{-1}$

B.  $20 \text{ m s}^{-1}$

C.  $30 \text{ m s}^{-1}$

D.  $40 \text{ m s}^{-1}$

**Answer: D**



[Watch Video Solution](#)

63. Three identical particles are joined together by a thread as shown in figure. All the particles are moving in a horizontal plane. If the velocity of the outermost particle is  $v_0$ , then the ratio of tension in the three



sections of the string ( $T_1:T_2:T_3 = ?$ ) is

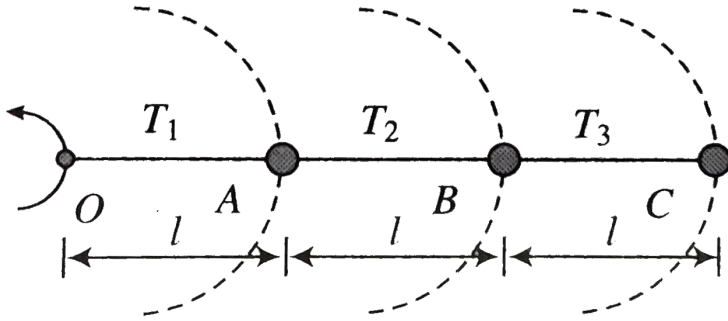

- A. 3:5:7
- B. 3:4:5
- C. 7:11:6
- D. 3:5:6

**Answer: D**

[Watch Video Solution](#)

64. A particle moves from rest at A on the surface of a smooth circular cylinder of radius  $r$  as shown. At B it leaves the cylinder. The equation

releaseder . The equation relating  $\alpha$  and  $\beta$  is

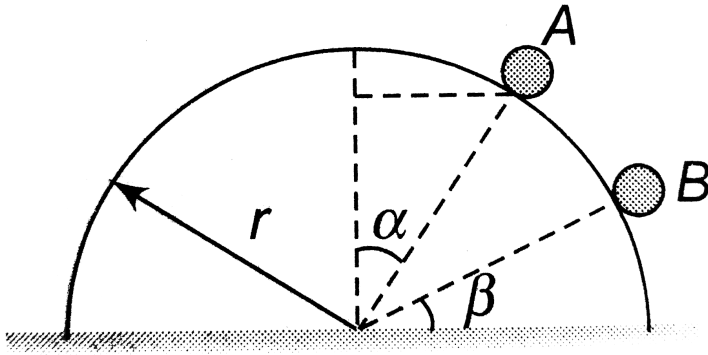

- A.  $3 \sin \alpha = 2 \cos \beta$
- B.  $2 \sin \alpha = 3 \cos \beta$
- C.  $3 \sin \beta = 2 \cos \alpha$
- D.  $2 \sin \beta = 3 \cos \alpha$

**Answer: C**



**Watch Video Solution**

65. A ball is placed on a smooth inclined plane of inclination  $\theta = 30^\circ$  to the horizontal, which is rotating at frequency 0.5 Hz about a vertical axis passing through its lower end. At what distance from the lower end does the ball remain at rest?

A.  $0.87m$

B.  $0.33m$

C.  $0.5m$

D.  $0.67m$

**Answer: D**



[Watch Video Solution](#)

66. A particle suspended by a light inextensible thread of length  $l$  is projected horizontally from its lowest position with velocity  $\sqrt{7gl/2}$ . The string will slack after swinging through an angle equal to

A.  $30^\circ$

B.  $90^\circ$

C.  $120^\circ$

D.  $150^\circ$

**Answer: C**



**Watch Video Solution**

67. The kinetic energy of a particle moving along a circle of radius  $R$  depends on the distance covered  $s$  as  $K.E = KS^2$  where  $K$  is a constant.

Find the force acting on the particle as a function of  $S$  -

A.  $\frac{2as^2}{R}$

B.  $2as \left( 1 + \frac{s^2}{R^2} \right)^{1/2}$

C.  $as \left( 1 + \frac{s^2}{R^2} \right)^{1/2}$

D. None of these

Answer: B

[▶ Watch Video Solution](#)

## Match the columns

1. Three balls each of mass 1 kg are attached with three strings each of length 1 m as shown in figure. They are rotated in a horizontal circle with angular velocity  $\omega = 4\text{rad s}^{-1}$  about point O. find the tensions .

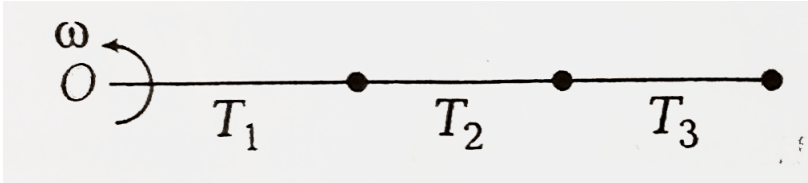

[▶ Watch Video Solution](#)

2. A particle is suspended from a string of length  $R$ . It is given a velocity  $u = 3\sqrt{gR}$  at the bottom

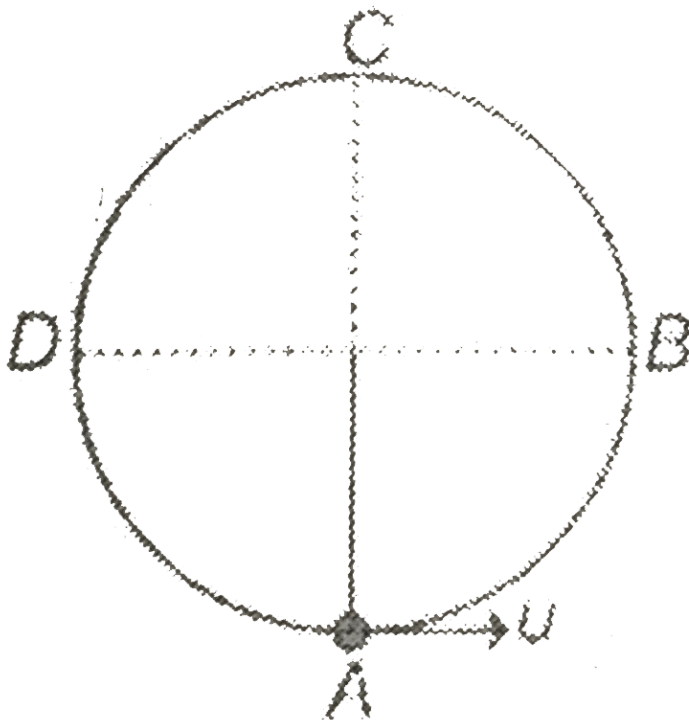

Match the following

Table-1

- (A) Velocity at B
- (B) Velocity at C
- (C) Tension in string at B
- (D) Tension in string at C

Table-2

- (P)  $7mg$
- (Q)  $\sqrt{5gR}$
- (R)  $\sqrt{7gR}$
- (S)  $5mg$
- (T) None



Watch Video Solution

3. What is the amount of work done in bringing a mass from the surface of Earth on one side to a point diametrically opposite on the other side?



[Watch Video Solution](#)

## Medical entrances s gallery

1. in the given figure,  $\alpha = 15m/s^2$  represents the total accleration of a particle moving in the clockwise direction on a circle radius  $R = 2.5m$  aat a

given of time The speed of the particle is

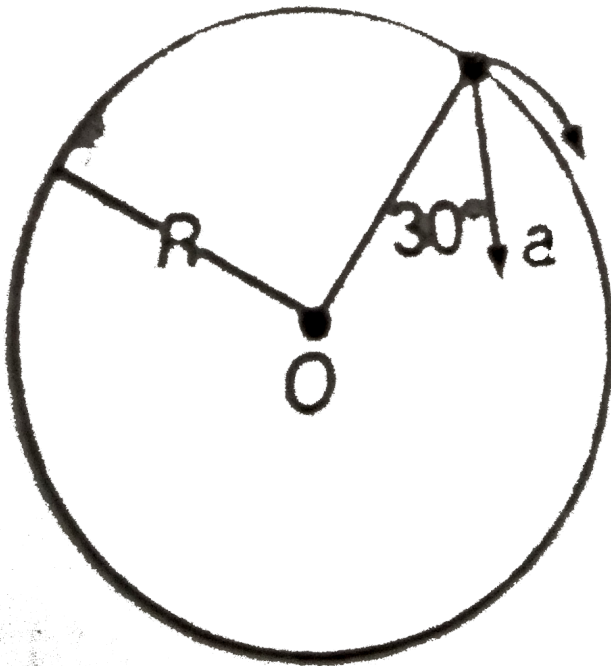

A.  $4.5\text{m/s}$

B.  $5.0\text{ m/s}$

C.  $5.7\text{ m/s}$

D.  $6.2\text{m/s}$

**Answer: C**



**Watch Video Solution**



2. A car is negotiating a curved road of radius  $R$ . The road is banked at angle  $\theta$ . The coefficient of friction between the tyres of the car and the road is  $\mu_s$ . The maximum safe velocity on this road is

- A.  $4.5\text{m/w}$
- B.  $5.0\text{ m/s}$
- C.  $5.7\text{ m/s}$
- D.  $6.2\text{m/s}$

**Answer: C**



[Watch Video Solution](#)

3. A uniform circular disc of radius  $50\text{ cm}$  at rest is free to turn about an axis which is perpendicular to its plane and passes through its centre. It is subjected to a torque which produces a constant angular acceleration of  $2\text{rads}^{-2}$ . Its net acceleration in  $\text{ms}^{-2}$  the end of  $2\text{s}$  is approximately

A. 7

B. 6

C. 3

D. 8

**Answer: D**



**Watch Video Solution**

4. What is the minimum velocity with which a body of mass  $m$  must enter a vertical loop of radius  $R$  so that it can complete the loop?

A.  $\sqrt{2gR}$

B.  $\sqrt{3gR}$

C.  $\sqrt{5gR}$

D.  $\sqrt{gR}$

**Answer: C**

 [Watch Video Solution](#)

5. A particle of mass 10g moves along a circle of radius 6.4 cm with a constant tangential acceleration. What is the magnitude of this acceleration, if the kinetic energy of the particle becomes equal to  $8 \times 10^{-4}$  J by the end of the second revolution after the beginning of the motion?

A.  $0.15ms^{-2}$

B.  $0.18ms^{-2}$

C.  $0.2ms^{-2}$

D.  $0.1ms^{-2}$

**Answer: D**

 [Watch Video Solution](#)

6. A fighter plane is pulling out for a dive at a speed of  $900\text{km/h}$ . Assuming its path to be a vertical circle of radius  $2000\text{m}$  and its mass to be  $16000\text{kg}$ , find the force exerted by the air on it at the lowest point.

Take  $g = 9.8\text{m/s}^2$

A.  $3.28 \times 10^5\text{N}$

B.  $6.56 \times 10^5\text{N}$

C.  $9.28 \times 10^5\text{N}$

D.  $12.56 \times 10^5\text{N}$

**Answer: A**



[Watch Video Solution](#)

7. A particle is moving in a curved path. Which of the following quantities may remain constant during its motion?

A. Acceleration

B. Velocity

C. Magnitude of acceleration

D. None of these

**Answer: C**



[Watch Video Solution](#)

**8.** The ratio of angular speed of a second-hand to the hour-hand of a watch is

A. 3600 : 1

B. 720 : 1

C. 72 : 1

D. 60 : 1

**Answer: B**



[Watch Video Solution](#)

9. If the length of second's hand of a clock is 10 cm, the speed of its tip (in  $\text{cm s}^{-1}$ ) is nearly

A. 2

B. 0.5

C. 1.5

D. 1

**Answer: D**



[Watch Video Solution](#)

10. A particle is moving uniformly in a circular path of radius  $r$ . When it moves through an angular displacement  $\theta$ , then the magnitude of the corresponding linear displacement will be

A.  $2r \cos\left(\frac{\theta}{2}\right)$

B.  $2r \cot\left(\frac{\theta}{2}\right)$

C.  $2r \tan\left(\frac{\theta}{2}\right)$

D.  $2r \sin\left(\frac{\theta}{2}\right)$

**Answer: D**



**Watch Video Solution**

**11.** A rotating wheel changes angular speed from 1800 rpm to 3000 rpm in 20 s. What is the angular acceleration assuming to be uniform?

A.  $60\pi \text{ rad s}^{-2}$

B.  $90\pi \text{ rad s}^{-2}$

C.  $2\pi \text{ rad s}^{-2}$

D.  $40\pi \text{ rad s}^{-2}$

**Answer: C**



**Watch Video Solution**

12. The expression from centripetal force depends upon mass of body, speed of the body and the radius of circular path. Find the expression for centripetal force.

A.  $\frac{Mv^2}{R}$

B.  $\frac{M^2v}{R}$

C.  $\frac{Mv}{R^2}$

D.  $\frac{Mv}{R}$

**Answer: A**



[Watch Video Solution](#)

13. Uniform circular motion is an example of

A. constant speed motion

B. constant velocity motion



C. non-accelerated motion

D. Zero accelerated motion

**Answer: A**



[Watch Video Solution](#)

14. A stone tied to a rope is rotated in a vertical circle with uniform speed. If the difference between the maximum and minimum tensions in the rope is 20 N, mass of the stone in kg is (take,  $g = 10 \text{ ms}^{-2}$ )

A. 0.75

B. 1.0

C. 1.5

D. 0.5

**Answer: B**



[Watch Video Solution](#)

15. A particle moving in uniform circle makes 18 revolutions in 1 minutes. If the radius of the circle is 10 cm, the speed of the particle is

A.  $3\pi \times 10^{-2}ms^{-1}$

B.  $4\pi \times 10^{-2}ms^{-1}$

C.  $5\pi \times 10^{-2}ms^{-1}$

D.  $6\pi \times 10^{-2}ms^{-1}$

**Answer: D**



[Watch Video Solution](#)

16. A car of mass  $1000kg$  negotiates a banked curve of radius  $90m$  on a frictionless road. If the banking angle is  $45^\circ$  the speed of the car is:

A.  $20ms^{-1}$

B.  $30ms^{-1}$

C.  $5ms^{-1}$

D.  $10ms^{-1}$

**Answer: B**



[Watch Video Solution](#)

17. On a railway curve, the outside rail is laid higher than the inside one so that resultant force exerted on the wheels of the rail car by the tops of the rails will

- A. equilibrate the centripetal force
- B. be vertical
- C. be decreased
- D. have a horizontal inward component

**Answer: D**



[Watch Video Solution](#)

18. One end of a string of length 1 m is tied to a body of mass 0.5 kg. It is whirled in a vertical circle with angular velocity  $4 \text{ rad s}^{-1}$ . Find the tension in the string when the body is at the lower most point of its motion. (take,  $g = 10 \text{ ms}^{-1}$ )

- A. 3 N
- B. 5 N
- C. 8 N
- D. 13 N

**Answer: D**



[Watch Video Solution](#)

19. A cane filled with water is revolved in a vertical circle of radius 4 m and water just does not fall down. The time period of revolution will be –

- A. 4s

B. 2s

C. 1s

D. 6s

**Answer: A**



**Watch Video Solution**