



PHYSICS

BOOKS - DC PANDEY ENGLISH

CURRENT ELECTRICITY

Only One Option is Correct

1. The following sets of values for C_v and C_p of an ideal gas have been reported by different students. The units are $\text{cal mole}^{-1} \text{K}^{-1}$. Which of these sets is most reliable?

A. A) $C_V = 3, C_P = 5$

B. B) $C_V = 4, C_P = 6$

C. C) $C_V = 3, C_P = 2$

D. D) $C_V = 3, C_P = 4.2$

Answer: A



Watch Video Solution

2. A diatomic ideal gas undergoes a thermodynamic change according to the P-V diagram shown in the figure. The total

heat given to the gas is nearly (use $\ln 2=0.7$):

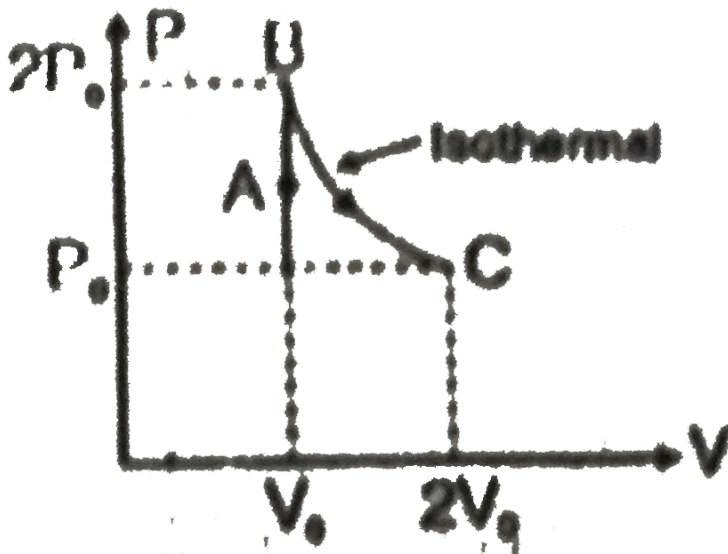

A. A) $2.5p_0V_0$

B. B) $1.4p_0V_0$

C. C) $3.9p_0V_0$

D. D) $1.1p_0V_0$

Answer: C



Watch Video Solution

3. $P - T$ diagram is shown in Fig. Choose the corresponding $V - T$ diagram.

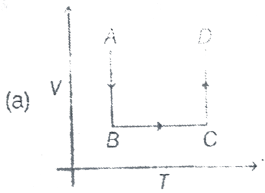
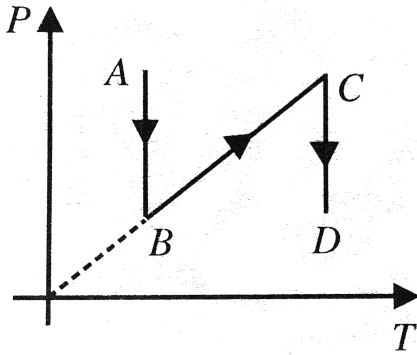

A.

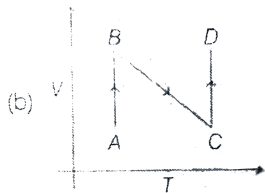

B.

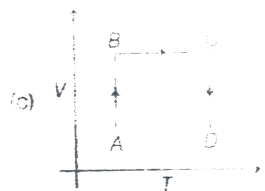

C.

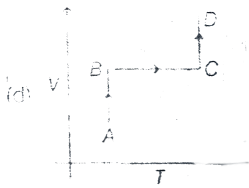

D.

Answer: D

[▶ Watch Video Solution](#)

4. A small quantity mass m , of water at a temperature θ (in $^{\circ}C$) is poured on to a larger mass M of ice which is at its melting point. If c is the specific heat capacity of water and L the specific latent heat of fusion of ice, then the mass of ice melted is give by

A. A) $\frac{ML}{mc\theta}$

B. B) $\frac{mc\theta}{ML}$

C. C) $\frac{Mc\theta}{L}$

D. D) $\frac{mc\theta}{L}$

Answer: D

 Watch Video Solution

5. Two rods having length l_1 and l_2 , made of materials with the linear coefficient of expansion α_1 and α_2 were welded together. The equivalent coefficients of linear expansion for the obtained rod:-

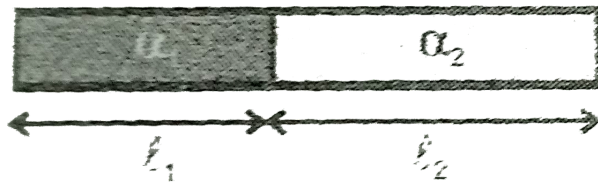

A. A) $\frac{l_1\alpha_2 + l_2\alpha_1}{l_1 + l_2}$

B. B) $\frac{l_1\alpha_1 + l_2\alpha_2}{\alpha_1 + \alpha_2}$

C. C) $\frac{l_1\alpha_1 + l_2\alpha_2}{l_1 + l_2}$

D. D) $\frac{l_2\alpha_1 + l_1\alpha_2}{\alpha_1 + \alpha_2}$

Answer: C



Watch Video Solution

6. A wall is made of equally thick layers A and B of different materials. Thermal conductivity of A is twice that of B. In the steady state, the temperature difference across the wall is $36^\circ C$. The temperature difference across the layer A is

A. A) $6^\circ C$

B. B) $12^\circ C$

C. C) $18^\circ C$

D. D) $24^{\circ}C$

Answer: B



Watch Video Solution

7. A wall consists of alternating blocks with length 'd' and coefficient of thermal conductivity k_1 and k_2 . The cross sectional area of the blocks are the same. The equivalent coefficient of thermal conductivity of the wall between left

and right is:-

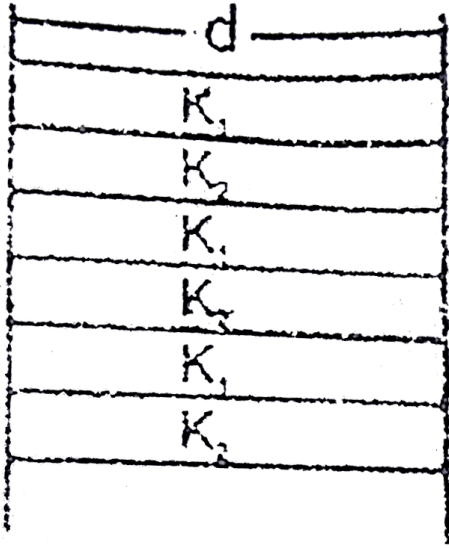

A. A) $\frac{K_1 + K_2}{3}$

B. B) $\frac{(K_1 + K_2)}{2}$

C. C) $\frac{3K_1K_2}{K_1 + K_2}$

D. D) $\frac{2K_1K_2}{K_1 + K_2}$

Answer: B



Watch Video Solution

8. A rod of length 2m rests on smooth horizontal floor. If the rod is heated from $0^{\circ}C$ to $20^{\circ}C$. Find the longitudinal strain developed ? ($\alpha = 5 \times 10^{-5} / .^{\circ}C$)

A. 10^{-3}

B. 2×10^{-3}

C. zero

D. 10^{-4}

Answer: C



Watch Video Solution

9. Steam at $100^{\circ}C$ is added slowly to 1400 gm of water at $16^{\circ}C$ until the temperature of water is raised to $80^{\circ}C$. The mass of steam required to do this is ($L_V = 540 \text{ cal/g}$)

A. A) 160 g

B. B) 120 g

C. C) 250 g

D. D) 320 g

Answer: A



[Watch Video Solution](#)

10. A block of ice with mass m falls into a lake. After impact, a mass of ice $\frac{m}{5}$ melts. Both the block of ice and the lake have a

temperature of $0^{\circ}C$. If L represents the latent heat of fusion,

the distance the ice falls before striking the surface is

A. A) $\frac{L}{5g}$

B. B) $\frac{5L}{g}$

C. C) $\frac{gL}{5m}$

D. D) $\frac{mL}{5g}$

Answer: A



Watch Video Solution

11. The specific heat of a metal at low temperatures varies according to $S = aT^3$, where a is a constant and T is absolute temperature. The heat energy needed to raise unit mass of the metal from temperature $T = 1K$ to $T = 2K$ is

A. A) $3a$

B. B) $\frac{15a}{4}$

C. C) $\frac{2a}{3}$

D. D) $\frac{12a}{5}$

Answer: B



Watch Video Solution

12. Steam at $100^{\circ}C$ is passed into $1.1kg$ of water contained in a calorimeter of water equivalent $0.02kg$ at $15^{\circ}C$ till the temperature of the calorimeter and its contents rises to $80^{\circ}C$. The mass of the steam condensed in kilogen is:

A. A) 0.130

B. B) 0.065

C. C) 0.260

D. D) 0.460

Answer: A



Watch Video Solution

13. Two sheets of thickness d and $2d$ and same area are touching each other on their face. Temperature T_A, T_B, T_C shown are in geometric progression with common ratio $r = 2$. Then ratio of thermal conductivity of thinner and thicker

sheet are

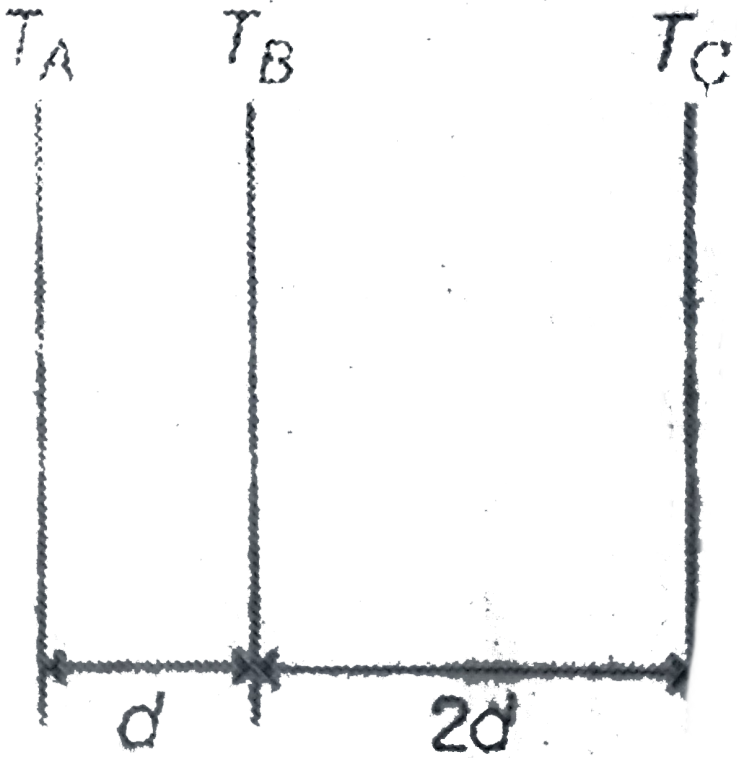

A. A) 1

B. B) 2

C. C) 0.5

D. D) 4

Answer: A



Watch Video Solution

14. A composite rod made of three rods of equal length and cross-section as shown in fig. The thermal conductivities of the materials of the rods are $K/2$, $5K$ and K respectively. The end A and end B are at constant temperatures. All heat entering the face A goes out of the end B there being no loss of heat from the sides of the bar. The effective thermal conductivity of the bar is

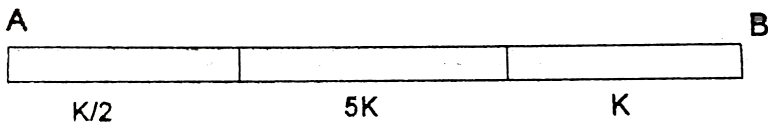

A. A) $15K/16$

B. B) $6K/13$

C. C) $5K / 16$

D. D) $2K / 13$

Answer: A



Watch Video Solution

15. A black metal foil is warmed by radiation from a small sphere at temperature T and at a distance d it is found that the power received by the foil is P . If both the temperature and the distance are doubled the power received by the foil will be .

A. A) $16P$

B. B) $4P$

C. C) $2P$

D. D) P

Answer: B



Watch Video Solution

16. Two perfect monoatomic gases at absolute temperature T_1 and T_2 are mixed. There is no loss of energy. Find the temperature of the mixture if the number of moles in the gases are n_1 and n_2 .

A. $\frac{T_1 + T_2}{n_1 + n_2}$

B. $\frac{T_1}{n_1} + \frac{T_2}{n_2}$

C. $\frac{n_2 T_1 + n_1 T_2}{n_1 + n_2}$

D. $\frac{n_1 T_1 + n_2 T_2}{n_1 + n_2}$

Answer: D



Watch Video Solution

17. For a monoatomic ideal gas undergoing an adiabatic change, the relation between temperature and volume $TV^x =$ constant, where x is

A. $\frac{7}{5}$

B. $\frac{2}{5}$

C. $\frac{2}{3}$

D. $\frac{1}{3}$

Answer: C



Watch Video Solution

18. A black body calorimeter filled with hot water cools from $60^{\circ}C$ to $50^{\circ}C$ in 4 min and $40^{\circ}C$ to $30^{\circ}C$ in 8 min . The approximate temperature of surrounding is :

- A. 10°
- B. $15^{\circ}C$
- C. $20^{\circ}C$
- D. $25^{\circ}C$

Answer: B



[Watch Video Solution](#)

19. In the process $PV = \text{constant}$, pressure (P) versus density (ρ) graph of an ideal gas is

- A. a straight line parallel to P-axis
- B. a straight line parallel to ρ -axis
- C. a straight line passing through origin
- D. a parabola

Answer: C

 [Watch Video Solution](#)

20. Pressure versus temperature graphs of an ideal gas are as shown in figure. Choose the wrong statement

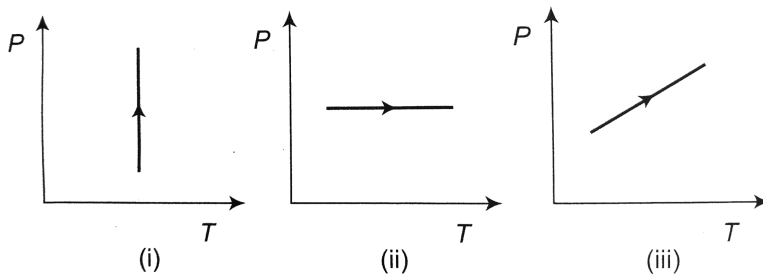

- A. Density of gas is increasing in graph (i)
- B. Density of gas is decreasing in graph (ii)
- C. Density of gas constant in graph (iii)
- D. None of the above

Answer: C

 [Watch Video Solution](#)

21. Change in internal energy of an ideal gas is given by $\Delta U = nC_V\Delta T$. This is applicable for (C_V =molar heat capacity at constant volume)

- A. A) isochoric process only
- B. B) all processes

C. C) a process where ΔT is positive

D. D) all the processes except isothermal process

Answer: B



Watch Video Solution

22. A gas is expanded to double its volume by two different processes. One is isobaric and the other is isothermal. Let W_1 and W_2 be the respective work done, then find W_1 and W_2

A. A) $W_2 = W_1 \ln(2)$

B. B) $W_2 = \frac{W_1}{\ln(2)}$

C. C) $W_2 = \frac{W_1}{2}$

D. D) Data is insufficient

Answer: A



Watch Video Solution

23. The quantity $\frac{pV}{kt}$ represents

- A. A) number of moles of the gas
- B. B) total mass of the gas
- C. C) number of molecules in the gas
- D. D) density of the gas

Answer: C



Watch Video Solution

24. The freezing point on a thermometer is marked as -20° and the boiling point as 130° . A temperature of human body ($34^{\circ}C$) on this thermometer will be read as

A. A) 31°

B. B) 51°

C. C) 20°

D. D) None of these

Answer: A



Watch Video Solution

25. If two rods of length L and $2L$ having coefficients of linear expansion α and 2α respectively are connected so that total

length becomes $3L$, the average coefficient of linear expansion of the composite rod equals

A. A) $\frac{3}{2}\alpha$

B. B) $\frac{5}{2}\alpha$

C. C) $\frac{5}{3}\alpha$

D. D) None of these

Answer: C

 [Watch Video Solution](#)

26. Sixty per cent of given sample of oxygen gas when raised to a high temperature dissociates into atoms Ratio of its initial heat capacity (at constant volume) to the final heat capacity (at constant volume) will be

A. A) $\frac{8}{7}$

B. B) $\frac{25}{26}$

C. C) $\frac{10}{7}$

D. D) $\frac{25}{27}$

Answer: C



[Watch Video Solution](#)

27. In a cyclic process shown in the figure an ideal gas is adiabatically taken from B to A , the work done on the gas during the process B to A is $30, J$ when the gas is taken from A to B the heat absorbed by the gas is $20J$ Then change in

internal energy of the gas in the process A to B is :

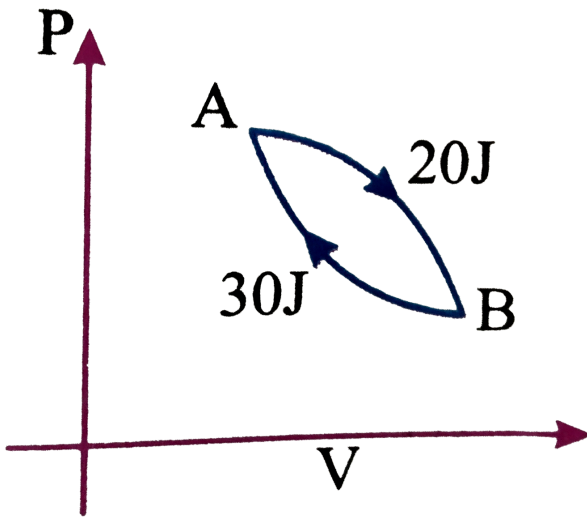

- A. 20 J
- B. -30 J
- C. 50 J
- D. -10 J

Answer: B



[Watch Video Solution](#)

28. In certain region of space there are n number of molecules per unit volume. The temperature of the gas is T . The pressure of the gas will be

(k = Boltzmann's constant and R = universal gas constant)

A. nRT

B. nKT

C. $\frac{nT}{K}$

D. $\frac{nT}{R}$

Answer: B



Watch Video Solution

29. If pressure and temperature of an ideal gas are doubled and volume is halved, the number of molecules of the gas

- A. A) remain constant
- B. B) become half
- C. C) become two times
- D. D) become four times

Answer: B



[Watch Video Solution](#)

30. Internal energy of n_1 mol of hydrogen of temperature T is equal to the internal energy of n_2 mol of helium at temperature $2T$. The ratio n_1/n_2 is

A. $\frac{3}{5}$

B. $\frac{2}{5}$

C. $\frac{6}{5}$

D. $\frac{3}{7}$

Answer: C



Watch Video Solution

31. A graph is plotted with PV/T on y-axis and mass of the gas along x-axis for different gases. The graph is

A. A) a straight line paralalled to x-axis for all the gases

B. B) a straight line passing through origin with a slope

having a constant value for all the gases

C. C) a straight line passing through origin with a slope having different value for different gases

D. D) a straight line parallel to y-axis for all the gases

Answer: C



Watch Video Solution

32. An object is cooled from $75^{\circ}C$ to $65^{\circ}C$ in 2 min in a room at $30^{\circ}C$. The time taken to cool the same object from $55^{\circ}C$ to $45^{\circ}C$ in the same room is

A. A) 5 min

B. B) 3 min

C. C) 4 min

D. D) 2 min

Answer: C



Watch Video Solution

33. In which of the following process, convection does not take place primarily?

- (a) Sea and land breeze
- (b) Boiling of water
- (c) Warming of glass of bulb due to filament
- (d) Heating air around a furnace

A. A) Sea and land breeze

B. B) Boiling of water

C. C) Warming of glass of bulb due to filament

D. D) Heating of air around a furnace

Answer: C



[Watch Video Solution](#)

34. RMS speed of a monoatomic gas is increased by 2 times. If the process is done adiabatically then the ratio of initial volume to final volume will be

A. A) 4

B. B) $(4)^{2/3}$

C. C) $2^{3/2}$

D. D) 8

Answer: D



35. Rate of heat flow through two conducting rods of identical dimensions having thermal conductivities K_1 and K_2 and Q_1 and Q_2 when their ends are maintained at the same difference of temperature individually. When the two rods are joined in series with their ends maintained at the same temperature difference (as shown in the figure), the rate of heat flow will be

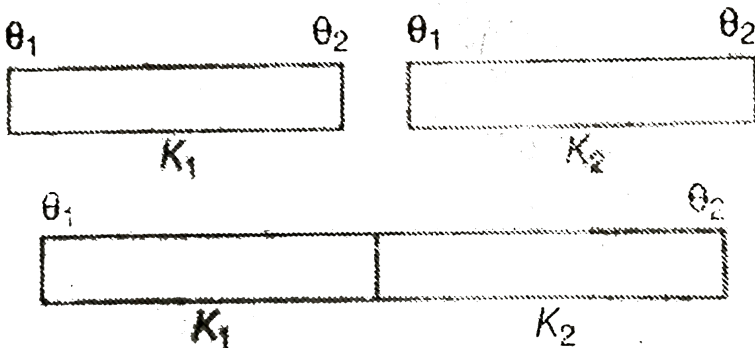

A. $\frac{Q_1 + Q_2}{2}$

B. $\frac{K_1 Q_2 + K_2 Q_1}{K_1 + K_2}$

C. $\frac{K_1 Q_1 + K_2 Q_2}{K_1 + K_2}$

D. $\frac{Q_1 Q_2}{Q_1 + Q_2}$

Answer: D



Watch Video Solution

36. Which one of the following would raise the temperature of 20 g of water at $30^\circ C$ most when mixed with?
(Specific heat of water is $1 \text{ cal} / \text{g} - .^\circ C$)

A. 20 g of water at $40^\circ C$

B. 40 g water at $35^\circ C$

C. 10 g water at $50^\circ C$

D. 4 g of water at $80^{\circ}C$

Answer: D



Watch Video Solution

37. 120 g of ice at $0^{\circ}C$ is mixed with 100 g of water at $80^{\circ}C$. Latent heat of fusion is 80 cal/g and specific heat of water is 1 cal/g $^{\circ}C$. The final temperature of the mixture is

A. $0^{\circ}C$

B. $40^{\circ}C$

C. $20^{\circ}C$

D. $10^{\circ}C$

Answer: A



[Watch Video Solution](#)

38. In the above problem mass of ice and water in the mixture when thermal equilibrium is attained is

- A. 40 g ice, 180 g water
- B. 60 g ice, 160 g water
- C. 20 g ice, 200 g water
- D. None of the above

Answer: C



[Watch Video Solution](#)

39. A metal ball immersed in water weighs w_1 at $0^\circ C$ and w_2 at $50^\circ C$. The coefficient of cubical expansion of metal is less than that of water. Then

A. $w_1 > w_2$

B. $w_1 < w_2$

C. $w_1 = w_2$

D. Data is insufficient

Answer: B



[Watch Video Solution](#)

40. A steel tape measures that length of a copper rod as 90.0 cm when both are at $10^\circ C$, the calibration temperature, for

the tape. What would the tape read for the length of the rod

when both are at $30^{\circ}C$. Given

$\alpha_{\text{steel}} = 1.2 \times 10^{-5}$ per. $^{\circ}C$ and $\alpha_{Cu} = 1.7 \times 10^{-5}$ per. $^{\circ}C$

A. 89.00cm

B. 90.21cm

C. 89.80cm

D. 90.01cm

Answer: D



Watch Video Solution

41. An aluminium measuring rod, which is correct at $5^{\circ}C$ measures the length of a line as 80 cm at $45^{\circ}C$ If thermal

coefficient of linear expansion of aluminium is

$2.50 \times 10^{-4} / ^\circ C$, the correct length of the line is:

A. A) 80.05cm

B. B) 79.92cm

C. C) 81.12cm

D. D) 79.62cm

Answer: A



[Watch Video Solution](#)

42. When a copper sphere is heated, maximum percentage change will be observed in :

A. maximum in radius

B. maximum in volume

C. maximum in density

D. equal in radius, volume and density

Answer: B



Watch Video Solution

43. A gas is expanded from volume $V_0 = 2V_0$ under three different processes. Process 1 is isobaric process, process 2 is isothermal and process 3 is adiabatic. Let ΔU_1 , ΔU_2 and ΔU_3 be the change in internal energy of the

gas in these three processes. then

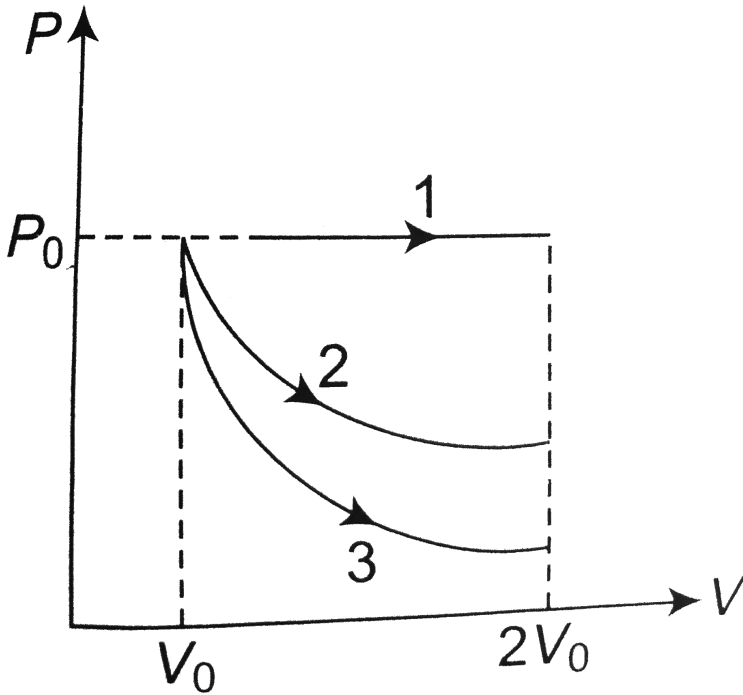

- A. $\Delta U_1 > \Delta U_2 > \Delta U_3$
- B. $\Delta U_1 < \Delta U_2 < \Delta U_3$
- C. $\Delta U_2 < \Delta U_1 < \Delta U_3$
- D. $\Delta U_2 < \Delta U_3 < \Delta U_1$

Answer: A



Watch Video Solution

44. During adiabatic process pressure (p) versus density (ρ) equation is

A. $p\rho^\lambda = \text{constant}$

B. $p\rho^{-\lambda} = \text{constant}$

C. $p^\lambda\rho^{1+\lambda} = \text{constant}$

D. $p^{1/\lambda}\rho^\lambda = \text{constant}$

Answer: B



Watch Video Solution

45. Gas at a pressure P_0 is contained in a vessel. If the masses of all the molecules are halved and their speeds are doubled.

The resulting pressure P will be equal to

A. $4p_0$

B. $2p_0$

C. p_0

D. $\frac{p_0}{2}$

Answer: B



Watch Video Solution

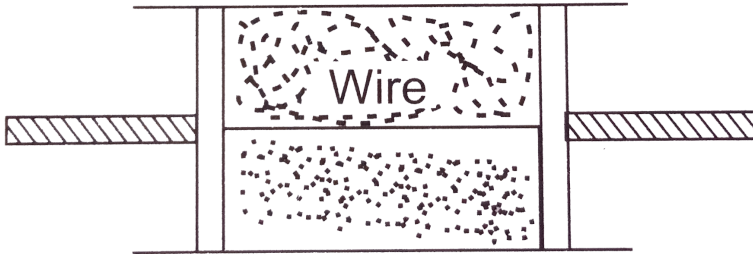

46.

A cylindrical tube of uniform cross-sectional area A is fitted with two air tight frictionless pistons. The pistons are connected to each other by a metallic wire. Initially the pressure of the gas is P_0 and temperature is T_0 , atmospheric pressure is also P_0 . Now the temperature of the gas is increased to $2T_0$, the tension in the wire will be

A. $2p_0A$

B. p_0A

C. $\frac{p_0A}{2}$

D. $4p_0A$

Answer: B

 Watch Video Solution

47. Pressure versus temperature graph of an ideal gas at constant volume V is shown by the straight line A. Now mass of the gas is doubled and the volume is halved, then the corresponding pressure versus temperature graph will be shown by the line

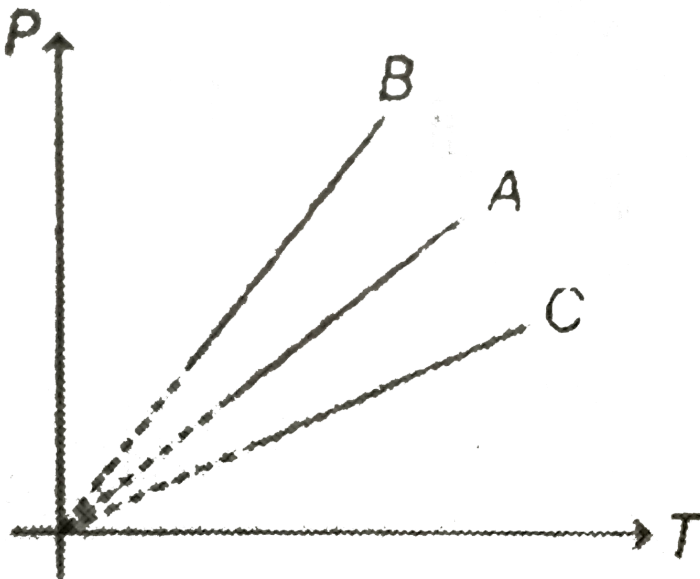

A. A

B. B

C. C

D. None of these

Answer: B



Watch Video Solution

48. The temperature of a gas contained in a closed vessel increases by $1^{\circ}C$ when pressure of the gas is increased by 1%. The initial temperature of the gas is

A. 100 K

B. $100^{\circ}C$

C. 250K

D. 250°C

Answer: A



Watch Video Solution

49. $P - V$ diagram of an ideal gas is as shown in figure. Work done by the gas in process $ABCD$ is

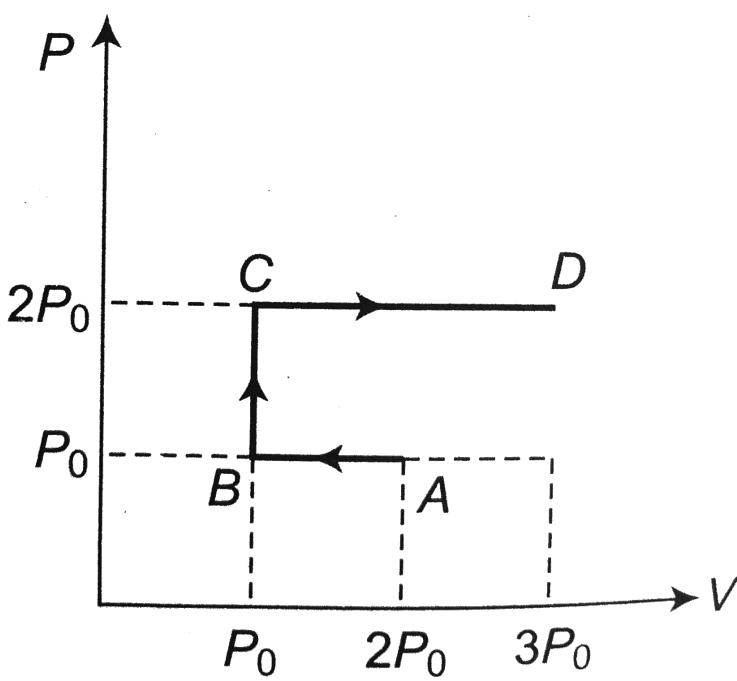

- A. $4p_0 V_0$
- B. $2p_0 V_0$
- C. $3p_0 V_0$
- D. $p_0 V_0$

Answer: C



Watch Video Solution

50. For an ideal monoatomic gas, the universal gas constant R is n times the molar heat capacity at constant pressure C_p . Here n is

A. 0.67

B. 1.4

C. 0.4

D. 1.67

Answer: C



[Watch Video Solution](#)

51. If gas molecules undergo, inelastic collision with the walls of the container

- A. the temperature of the gas will decrease
- B. the pressure of the gas will increase
- C. neither the temperature nor the pressure will change
- D. the temperature of the gas will increase

Answer: C



[Watch Video Solution](#)

52. Pressure versus temperature graph of an ideal gas of equal number of an ideal gas of equal number of mole of different volumes are plotted as shown in figure. Choose the correct

alternative.

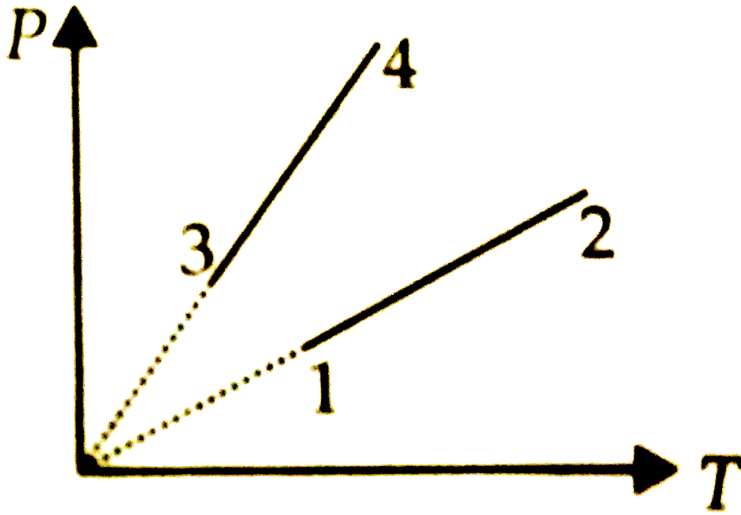

- A. $V_1 = V_2, V_3 = V_4$ and $V_2 > V_3$
- B. $V_1 = V_2, V_3 = V_4$ and $V_2 < V_3$
- C. $V_1 = V_2 = V_3 = V_4$
- D. $V_4 > V_3 > V_2 > V_1$

Answer: A



Watch Video Solution

53. In the $P - V$ diagram shown in figure ABC is a semicircle. The work done in the process ABC is

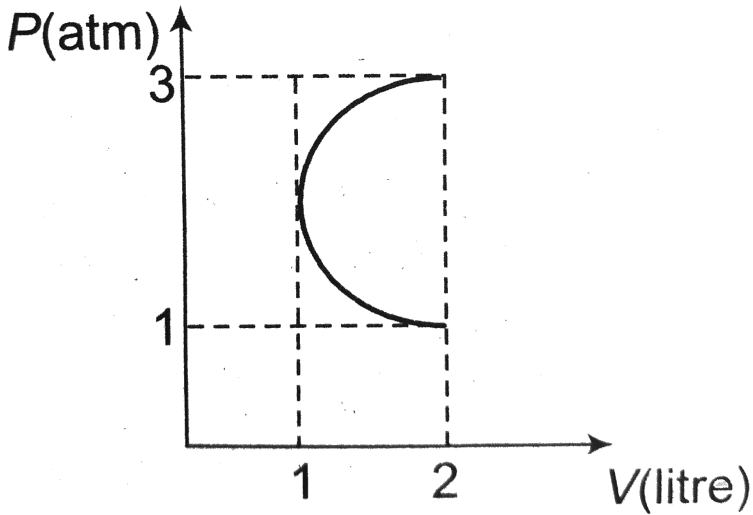

A. zero

B. $\frac{\pi}{2} \text{ atm} - L$

C. $-\frac{\pi}{2} \text{ atm} - L$

D. 4 atm-L

Answer: B



Watch Video Solution

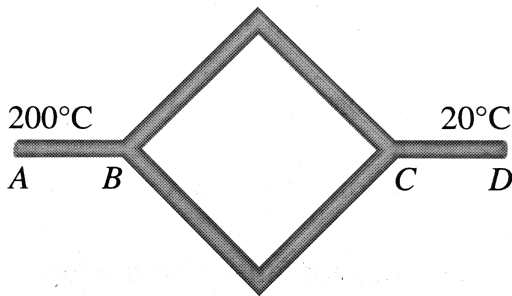

54.

Six identical conducting rods are joined as shown in Fig. Points A and D are maintained at temperatures $200^\circ C$ and $20^\circ C$ respectively. The temperature of junction B will be

A. $120^\circ C$

B. $100^{\circ}C$

C. $140^{\circ}C$

D. $80^{\circ}C$

Answer: C



Watch Video Solution

55. A thermodynamic system undergoes cyclic process $ABCD$ as shown in figure. The work done by the system is

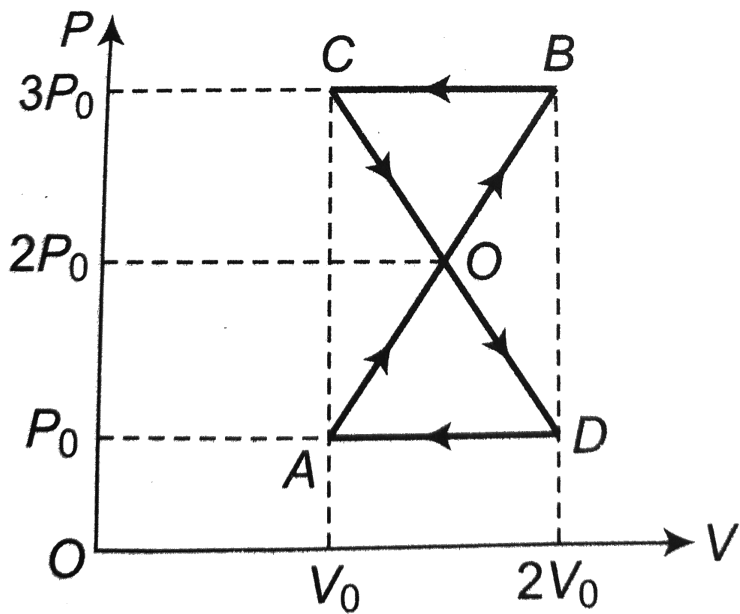

A. $p_0 V_0$

B. $2p_0 V_0$

C. $\frac{p_0 V_0}{2}$

D. zero

Answer: D



Watch Video Solution

56. At room temperature, the rms speed of the molecules of a certain diatomic gas is found to be 1930 m/s . The gas is

A. H_2

B. F_2

C. CL_2

D. CL_2

Answer: A



[Watch Video Solution](#)

57. 70 calories of heat is required to raise the temperature of 2 mole of an ideal gas at constant pressure from $30^\circ C$ to $35^\circ C$. The amount of heat required to raise the temperature of the

same gas through the same range at constant volume is

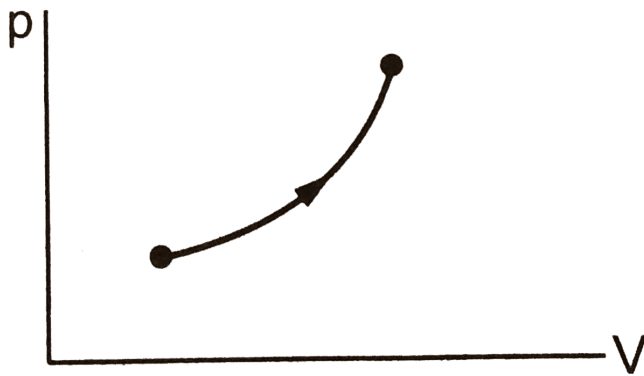

A. 30

B. 50

C. 70

D. 90

Answer: B



[Watch Video Solution](#)

58. If one mole of a mono-atomic gas ($\gamma = 5/3$) is mixed with one mole of a diatomic gas ($\gamma = 7/5$), the value of γ for the mixture is :

- A. 1.40
- B. 1.50
- C. 1.53
- D. 3.07

Answer: B



[Watch Video Solution](#)

59. A cylinder of radius R made of a material of thermal conductivity K_1 is surrounded by a cylindrical shell of inner

radius R and outer radius $2R$ made of a material of thermal conductivity K_2 . The two ends of the combined system are maintained at two different temperatures. There is no loss of heat across the cylindrical surface and the system is in steady state. The effective thermal conductivity of the system is

A. $K_1 + K_2$

B. $K_1 K_2 / (K_1 + K_2)$

C. $(K_1 + 3K_2) / 4$

D. $(3K_1 + K_2) / 4$

Answer: C



Watch Video Solution

60. The temperature of an ideal gas is increased from 120 K to 480 K. If at 120 K, the rms velocity of the gas molecules is v_{rms} then at 480 K, it becomes

A. $4v$

B. $2v$

C. $v/2$

D. $v/4$

Answer: B



[Watch Video Solution](#)

61. A spherical black body with a radius of 12 cm radiates 450 watt power at $500K$. if the radius were halved and the

temperature doubled, the power radiated in watt would be

- A. 225
- B. 450
- C. 900
- D. 1800

Answer: D



[Watch Video Solution](#)

62. A faulty thermometer reads $5^{\circ}C$ melting ice and $99^{\circ}C$ in steam. Find the correct temperature in $^{\circ}C$ when this faulty thermometer reads $52^{\circ}C$.

- A. $142^{\circ}F$

B. $130^{\circ} F$

C. $117^{\circ} F$

D. $122^{\circ} F$

Answer: D



[Watch Video Solution](#)

63. The efficiency of a Carnot's engine at a particular source and sink temperature is $\frac{1}{2}$. When the sink temperature is reduced by $100^{\circ} C$, the engine efficiency, becomes $\frac{2}{3}$. Find the source temperature.

A. 600K

B. 300K

C. 500K

D. 550K

Answer: A



Watch Video Solution

64. What must be the lengths of steel and copper rods at $0^{\circ}C$ for the difference in their lengths to be 10 cm at any common temperature?

$$(\alpha_{steel} = 1.2 \times 10^{-5} .^{\circ} K^{-1} \text{ and } \alpha_{copper} = 1.8 \times 10^{-5} .^{\circ} K^{-1})$$

A. 30 cm for steel and 20 cm for copper

B. 20 cm for steel and 40 cm for copper

C. 40 cm for steel and 30 cm for copper

D. 30 cm for steel and 40 cm for copper

Answer: A



Watch Video Solution

65. Earth receives $1400W/m^2$ of solar power. If all the solar energy falling on a lens of area $0.2m^2$ is focused on to a block of ice of mass 280 grams, the time taken to melt the ice will be..... Minutes. (Latent heat of fusion of ice= $3.3 \times 10^5 J/kg$)

A. 300s

B. 330s

C. 200s

D. 150s

Answer: B



Watch Video Solution

66. A thin rod of negligible mass and a cross-section of $2 \times 10^{-6} m^2$ suspended vertically from one end, has a length of $0.5m$ at $200^\circ C$. The rod is cooled at $0^\circ C$, but prevented from contracting by attaching a mass at the lower end. The value of this mass is : (Young's modulus $= 10^{11} N/m^2$, Coefficient of linear expansion $10^{-5} K^{-1}$ and $g = 10m/s^2$):

- A. 20 kg
- B. 30 kg
- C. 40 kg
- D. 50 kg

Answer: C



Watch Video Solution

67. A gas at the temperature 250 K is contained in a closed vessel. If the gas is heated through 1K, then the percentage increase in its pressure will be

A. 0.4 %

B. 0.2 %

C. 0.1 %

D. 0.8 %

Answer: A



Watch Video Solution

68. A certain amount of ideal monoatomic gas undergoes a process given by $TV^{1/2} = \text{constant}$. The molar specific heat of the gas for the process will be given by

- A. $R/2$
- B. $-3R/2$
- C. $3R/2$
- D. $-R/2$

Answer: D



[Watch Video Solution](#)

69. A rod of length 1000mm and co-efficient of linear expansion $\alpha = 10^{-4}$ per degree Celsius is placed in

horizontal smooth surface symmetrically between fixed walls separated by 1001mm . The young's modulus of rod is $10^{11}\text{N}/\text{m}^2$. If the temperature is increased by 20°C , then the stress developed in the rod is (in N/m^2)

A. 10

B. 10^8

C. 2×10^8

D. cannot be calculated

Answer: B



[Watch Video Solution](#)

70. One mole of a diatomic ideal gas undergoes a cyclic process ABC as shown in figure. The process BC is adiabatic.

The temperature at A,B and C are 400K, 800K and 600K respectively. Choose the correct statement:

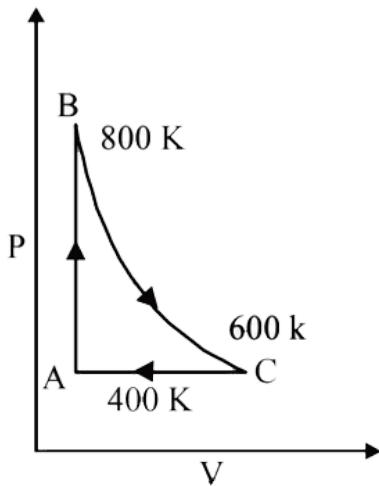

- A. The change in internal energy in the process AB is $-350R$.
- B. The change in internal energy in the process BC is $-500R$.
- C. The change in internal energy in whole cyclic process is $250R$.
- D. The change in internal energy in the process CA is $700R$.

Answer: B



Watch Video Solution

71. A copper block of mass 2.5 kg is heated in a furnace to a temperature of $500^{\circ}C$ and then placed on a large ice block. What is the maximum amount of ice that can melt? (Specific heat of copper $= 0.39Jg^{-1}K^{-1}$, heat of fusion of water $= 335Jg^{-1}$).

A. 1.5 kg

B. 3 kg

C. 4.5 kg

D. 6 kg

Answer: A



Watch Video Solution

72. Consider isothermal expansion of 0.5 mole of an ideal gas when Q amount of heat is added to it. Following graph shows variation in volume V with Q . Find the temperature of the gas

$$\left(\ln 3 \approx 1.1, R = \frac{25}{3} J/\text{mole} - K \right)$$

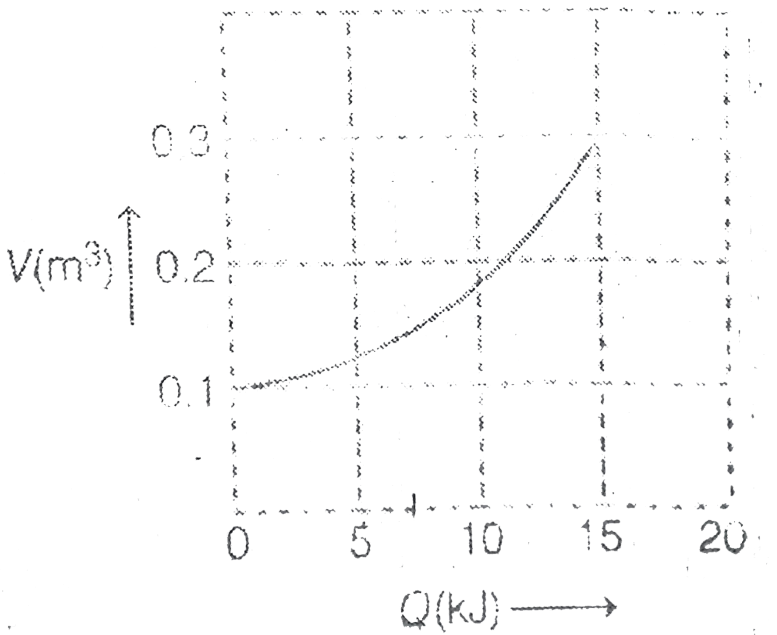

A. 360 K

B. 260 K

C. 390 K

D. 490 K

Answer: A



Watch Video Solution

73. A brass boiler has a base area of $0.15m^2$ and thickness 1.0 cm it boils water at the rate of $6.0kg/ \text{min}$, When placed on a gas. Estimate the temperature of the part of the flame in contact with the boiler. Thermal conductivity of brass $= 109J/s - .^\circ C$) and heat of vapourization of water $= 2256J/g$.

A. $350^\circ C$

B. $237^{\circ}C$

C. $300^{\circ}C$

D. $160^{\circ}C$

Answer: B



[Watch Video Solution](#)

74. A monoatomic ideal gas is used in a Carnot engine as the working substance. If during the adiabatic expansion the volume of the gas increases from $\frac{V}{8}$ to V , the efficiency of the engine is

A. 0.50

B. 0.25

C. 0.75

D. 0.40

Answer: C



Watch Video Solution

75. Two adiabatic containers have volumes V_1 and V_2 respectively. The first container has monoatomic gas at pressure p_1 and temperature T_1 . The second container has another monoatomic gas at pressure p_2 and temperature T_2 . When the two containers are connected by a narrow tube, the final temperature and pressure of the gases in the containers are P and T respectively. Then

$$\text{A. } T = \frac{p_1 V_1 T_2 + p_2 V_2 T_1}{p_1 V_1 + p_2 V_2}$$

$$\text{B. } T = \frac{p_1 V_1 T_2 + p_2 V_2 T_1}{p_1 V_2 + p_2 V_1}$$

$$\text{C. } p = \frac{p_1 V_2 + p_2 V_1}{V_1 + V_2}$$

$$\text{D. } p = \frac{p_1 V_1 + p_2 V_2}{V_1 + V_2}$$

Answer: D



Watch Video Solution

76. A uniform metallic disc of radius r and mass m is spinning with angular speed ω_0 about an axis passing through its centre and perpendicular to plane. If its temperature is increased (slightly) by ΔT its new angular speed is (The coefficient of linear expansion of the metal is α)

A. $\omega_0(1 + 2\alpha\Delta T)$

B. $\omega_0(1 + \alpha\Delta T)$

C. $\omega_0(1 - 2\alpha\Delta T)$

D. $\omega_0(1 - 3\alpha\Delta T)$

Answer: C

 [Watch Video Solution](#)

77. Three identical rods AB , CD and PQ are joined as shown. P and Q are mid points of AB and CD respectively. Ends A , B , C and D are maintained at $0^\circ C$, $100^\circ C$, $30^\circ C$ and $60^\circ C$

respectively. The direction of heat flow in PQ is

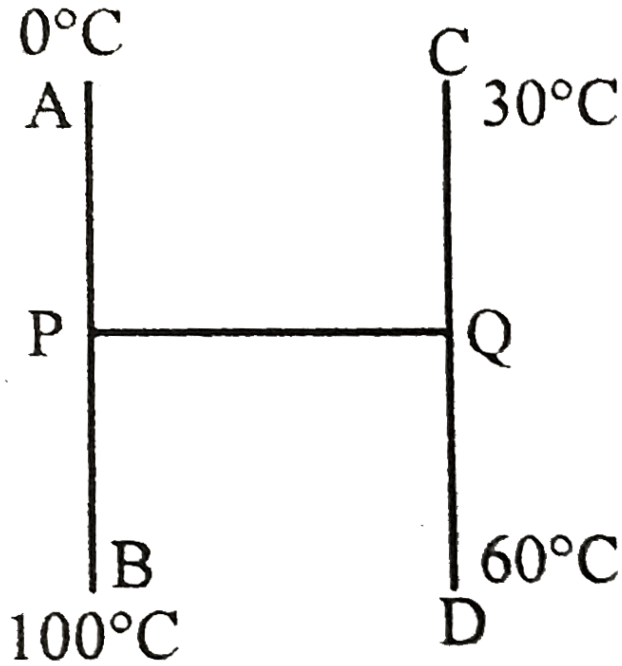

- A. from P to Q
- B. from Q to P
- C. heat does not flow in PQ
- D. Data is insufficient

Answer: A



Watch Video Solution

78. When the temperature of a gas filled in a closed vessel is increased by $1^{\circ}C$, its pressure increases by 0.4 percent. The initial temperature of gas was

- A. 250 K
- B. 500 K
- C. $250^{\circ}C$
- D. $25^{\circ}C$

Answer: A



[Watch Video Solution](#)

79. If an ideal gas is heated at constant pressure :

A. 60 %

B. 40 %

C. 75 %

D. 25 %

Answer: A



Watch Video Solution

80. Two identical vessels A and B contain masses m and $2m$ of same gas. The gases in the vessels are heated keeping their volumes constant and equal. The temperature-pressure curve for mass $2m$ makes angle α with T-axis and that and for mass m makes an angle β with T-axis then

A. $\tan \alpha = \tan \beta$

B. $\tan \alpha = 2 \tan \beta$

C. $\tan \beta = 2 \tan \alpha$

D. None of the Above

Answer: B



Watch Video Solution

81. The following graphs shows two isothermal process for a fixed mass of an ideal gas. Find the ratio of r.m.s speed of the

molecules at temperatures T_1 and T_2 ?

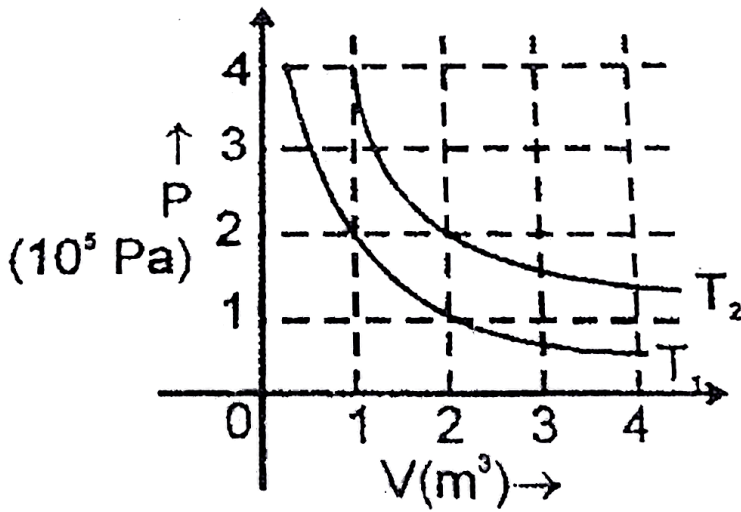

A. $2\sqrt{2}$

B. $\sqrt{2}$

C. $1/2$

D. $1/4$

Answer: C



Watch Video Solution

82. A sample of ideal gas ($\gamma = 1.4$) is heated at constant pressure. If an amount of 100 J heat is supplied to the gas, the work done by the gas is

A. 42.12J

B. 56.28J

C. 28.57J

D. 36.23J

Answer: C



[Watch Video Solution](#)

83. If 2 mol of an ideal monatomic gas at temperature T_0 are mixed with 4 mol of another ideal monatomic gas at

temperature $2T_0$ then the temperature of the mixture is

A. $\frac{5}{3}T_0$

B. $\frac{3}{2}T_0$

C. $\frac{4}{3}T_0$

D. $\frac{5}{4}T_0$

Answer: A



[Watch Video Solution](#)

84. Heat is supplied to a diatomic gas at constant pressure.

The ratio of $\Delta Q : \Delta U : \Delta W$ is

A. 5 : 3 : 2

B. 5 : 2 : 3

C. 7:5:2

D. 7:2:5

Answer: C



Watch Video Solution

85. The energy density $\frac{u}{V}$ of an ideal gas is related to its pressure P as

A. $\frac{U}{V} = 3p$

B. $\frac{U}{V} = \frac{3}{2}p$

C. $\frac{U}{V} = \frac{p}{3}$

D. $\frac{U}{V} = \frac{5}{2}p$

Answer: B



Watch Video Solution

86. A ring consisting of two parts ADB and ACB of same conductivity k carries an amount of heat H . The ADB part is now replaced with another metal keeping the temperature T_1 and T_2 constant. The heat carried increases to $2H$. What should be the conductivity of the new ADB ? Given $\frac{ACB}{ADB} = 3$

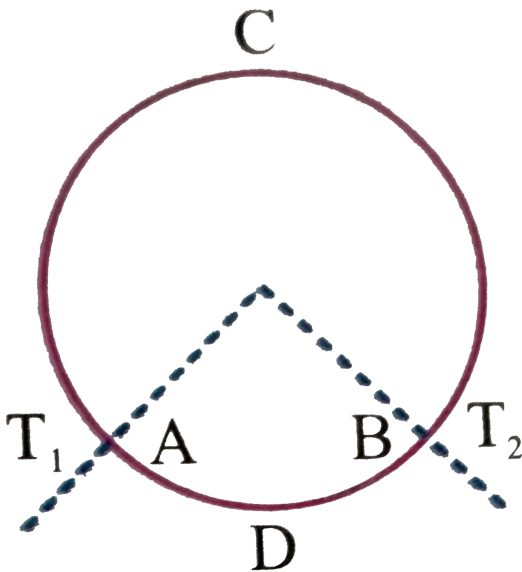

A. $\frac{7}{3}K$

B. $2K$

C. $\frac{5}{2}K$

D. $3K$

Answer: A



[Watch Video Solution](#)

87. Three conducting rods of same material and cross-section are shown in figure. Temperatures of A,D and C are maintained at $20^{\circ}C$, $90^{\circ}C$ and $0^{\circ}C$. The ratio of lengths BD and BC if

there is no heat flow in AB is

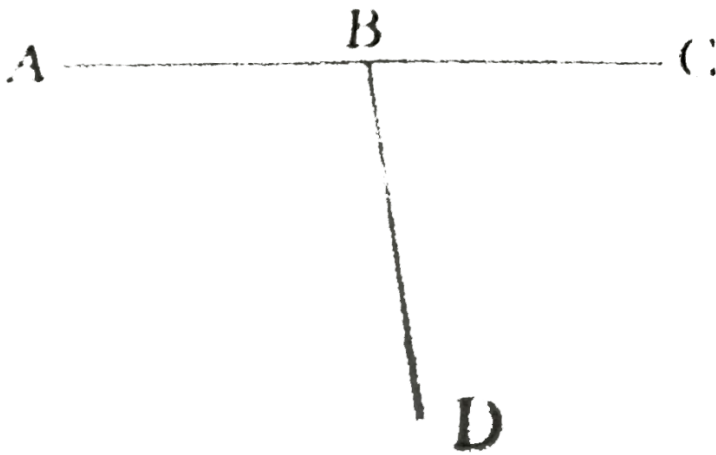

A. $2/7$

B. $7/2$

C. $9/2$

D. $2/9$

Answer: B



Watch Video Solution

88. Three rods of identical cross-sectional area and made from the same metal form the sides of an equilateral triangle ABC . The points A and B are maintained at temperature $\sqrt{3}T$ and T respectively. In the steady state, the temperature of the point C is T_C . Assuming that only heat conduction takes place, the value of T_C/T is equal to .

A. $\frac{1 + \sqrt{3}}{2}$

B. $\frac{1 - \sqrt{3}}{2}$

C. $\frac{1 + \sqrt{2}}{2}$

D. $\frac{1 - \sqrt{2}}{2}$

Answer: A



Watch Video Solution

89. An ideal monoatomic gas undergoes a cyclic process $ABCA$ as shown in the figure. The ratio of heat absorbed during AB to the work done on the gas during BC is

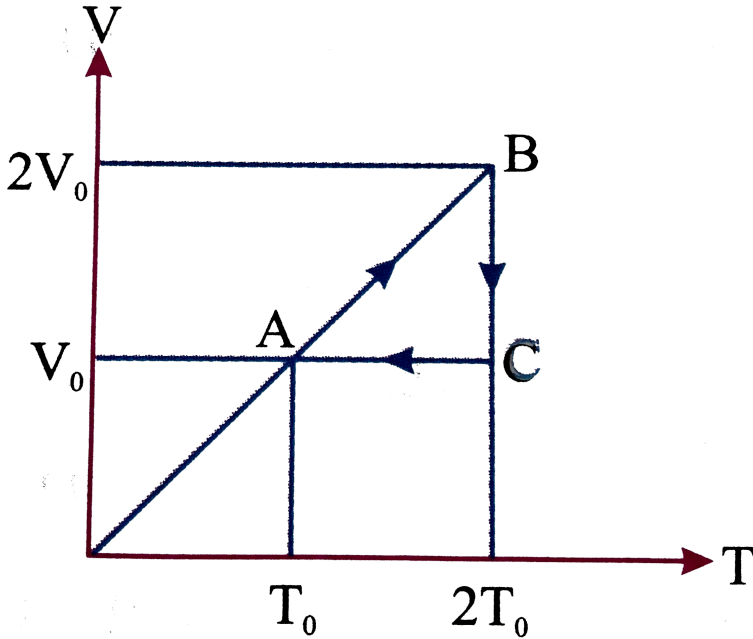

A. $\frac{5}{2 \ln 2}$

B. $\frac{5}{3}$

C. $\frac{5}{4 \ln 2}$

D. $\frac{5}{6}$

Answer: C

 Watch Video Solution

90. Three moles of an ideal monoatomic gas performs a cyclic process as shown in the figure. The temperatures in different states are $T_1 = 400K$, $T_2 = 800K$, $T_3 = 2400K$ and $T_4 = 1200K$

. Determine the work done by the gas during the cycle.

[Given $R = 8.31 \text{ J} \cdot \text{mol}^{-1} \cdot \text{K}^{-1}$]

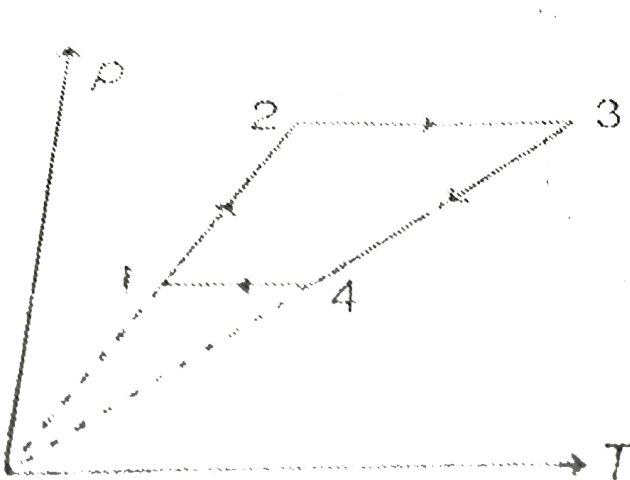

A. A. 1200 R

B. B. 3600 R

C. C. 2400 R

D. D. 2000 R

Answer: C



Watch Video Solution

91. A ideal gas ($\gamma = 1.5$) is expanded adiabatically. How many times has the gas to be expanded to reduce the root mean square velocity of molecules 2.0 times

A. 4 times

B. 16 times

C. 8 times

D. 2 times

Answer: B



[Watch Video Solution](#)

92. Three samples of the same gas A,B and C ($\gamma = 3/2$) have initially equal volume. Now the volume of each sample is doubled. The process is adiabatic for A. Isobaric for B and isothermal for C. If the final pressures are equal for all three samples, find the ratio of their initial pressures

A. $2\sqrt{2}:2:1$

B. $2\sqrt{2}:1:2$

C. $\sqrt{2}:1:2$

D. 2: 1: $\sqrt{2}$

Answer: B



Watch Video Solution

93. Temperature of an ideal gas is 300 K. The change in temperature of the gas when its volume changes from V to $2V$ in the process $p = aV$ (Here, a is a positive constant) is

A. 900 K

B. 1200 K

C. 600 K

D. 300 K

Answer: A



Watch Video Solution

94. 70 calories of heat is required to raise the temperature of 2 moles of an ideal gas at constant pressure from $40^{\circ}C$ to $45^{\circ}C$ ($R=2\text{cal/mol}\cdot^{\circ}C$). The gas may be

A. H_2

B. He

C. CO_2

D. NH_3

Answer: A



Watch Video Solution

95. Consider the two insulating sheets with thermal resistance R_1 and R_2 as shown in figure. The temperature θ is

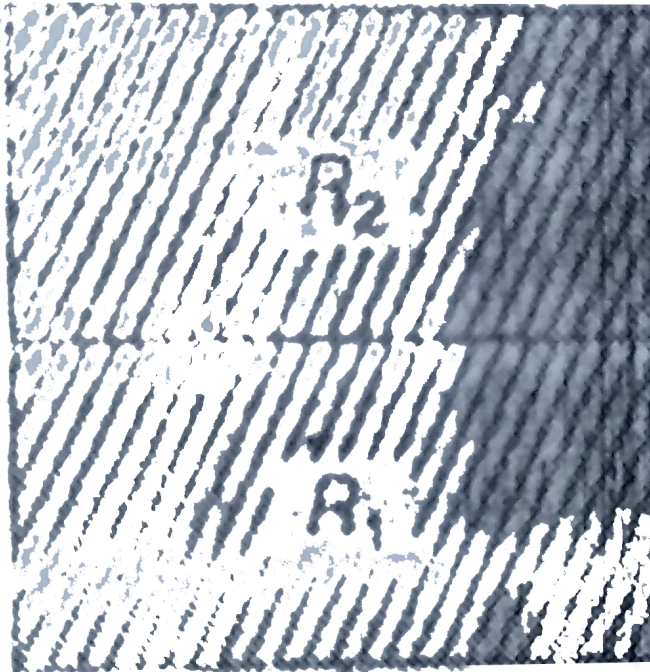

A.
$$\frac{\theta_1 \theta_2 R_1 R_2}{(\theta_1 + \theta_2)(R_1 + R_2)}$$

B. $\frac{\theta_1 R_1 + \theta_2 R_2}{R_1 + R_2}$

C. $\frac{(\theta_1 + \theta_2) R_1 R_2}{R_1^2 + R_2^2}$

D. $\frac{\theta_1 R_2 + \theta_2 R_1}{R_1 + R_2}$

Answer: D



Watch Video Solution

96. Four spheres A, B, C and D of different metals but all same radius are kept at same temperature. The ratio all their densities and specific heats are 2 : 3 : 5 : 1 and 3 : 6 : 2 : 4. Which sphere will show the fastest rate all cooling (initially) (assume black body radiation for all of them)

A. A

B. B

C. C

D. D

Answer: D

 [Watch Video Solution](#)

97. Temperature of a body θ is slightly more than the temperature of the surrounding θ_0 its rate of cooling (R) versus temperature of body (θ) is plotted its shape would be .

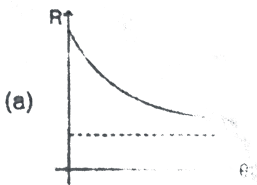

A.

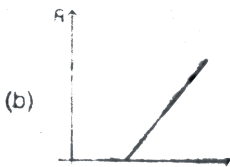

B.



C.

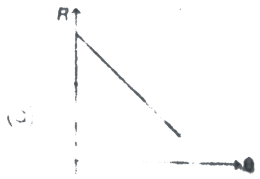

D.

Answer: B

 [Watch Video Solution](#)

98. A gas undergoes a change of state during which 100J of heat is supplied to it and it does 20J of work. The system is brought back to its original state through a process during which 20 J of heat is released by the gas. What is the work done by the gas in the second process?

A. 60 J

B. 40 J

C. 80 J

D. 20 J

Answer: A



[Watch Video Solution](#)

99. Unit mass of liquid of volume V_1 completely turns into a gas of volume V_2 at constant atmospheric pressure P and temperature T . The latent heat of vaporization is " L ". Then the change in internal energy of the gas is

A. L

B. $L + p_0(V_2 - V_1)$

C. $L - p_0(V_2 - V_1)$

D. zero

Answer: C



Watch Video Solution

100. Pressure versus density graph of an ideal gas is shown in figure

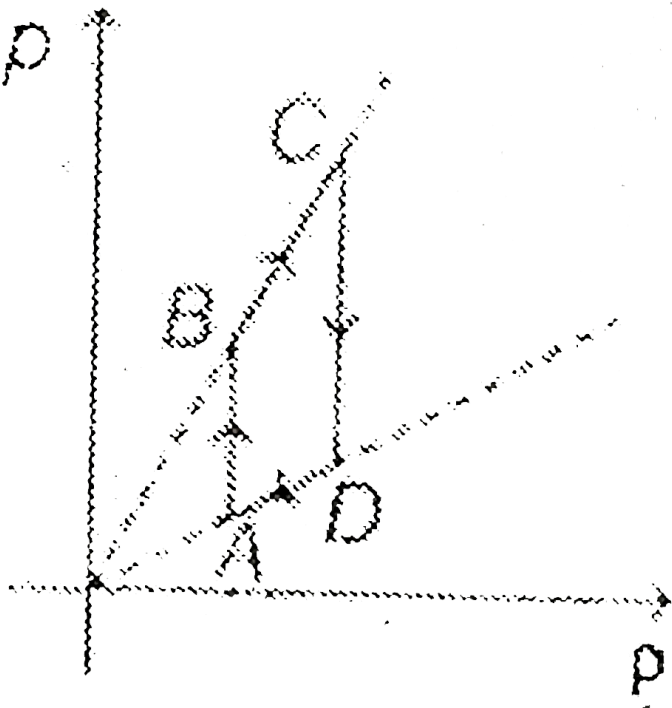

- A. during the process AB work done by the gas is positive
- B. during the process AB work done by the gas is negative
- C. during the process BC internal energy of the gas is increasing
- D. None of the above

Answer: D



Watch Video Solution

101. How much heat energy should be added to a mixture of 10g of hydrogen and 40g of helium to change the temp. by $50^{\circ}C$ kept in a closed vessel? Given $R = 2\text{cal}/\text{mole}K$

A. 2500 cal

B. 2750 cal

C. 2000 cal

D. None of these

Answer: B



Watch Video Solution

102. An ideal gas mixture filled inside a balloon expands according to the relation $PV^{2/3} = \text{constant}$. What will be the temperature inside the balloon

- A. increasing
- B. decreasing
- C. constant
- D. Cannot be defined

Answer: A



[Watch Video Solution](#)

103. Ideal gas is taken through the process shown in the figure

:

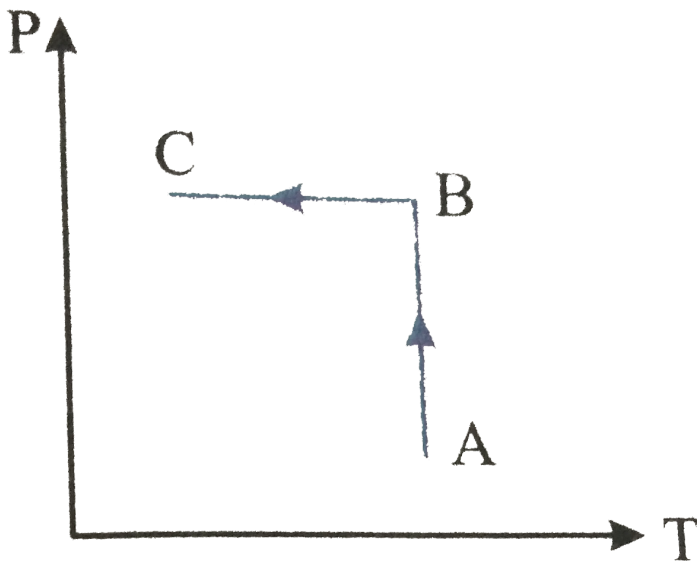

- A. In process AB, work done by system is positive
- B. In process AB, heat is rejected
- C. In process AB, internal energy increases
- D. In process AB internal energy decreases and in process BC, internal energy increases

Answer: B

 [Watch Video Solution](#)

104. Find $V_A - V_B$ in steady state

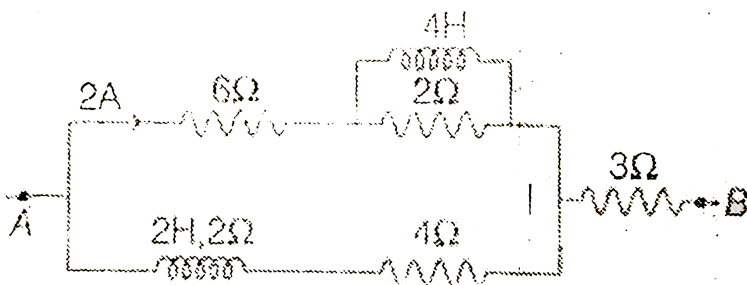

- A. temperature difference across AB and CD are equal
- B. temperature difference across AB is greater than that of across CD
- C. temperature difference across AB is less than that of across CD
- D. temperature difference may be equal or different depending on the thermal conductivity of the rod

Answer: C



Watch Video Solution

105. The specific heat of many solids at low temperatures varies with absolute temperature T according to the relation $S = AT^3$, where A is a constant. The heat energy required to raise the temperature of a mass m of such a solid from $T = 0$ to $T = 20$ K is

A. $4 \times 10^4 mA$

B. $2 \times 10^3 mA$

C. $8 \times 10^6 mA$

D. $2 \times 10^6 mA$

Answer: A



Watch Video Solution

106. Show that the volume thermal expansion coefficient for an ideal gas at constant pressure is $\frac{1}{T}$.



Watch Video Solution

107. A uniform solid brass sphere is rotating with angular speed ω_0 about a diameter. If its temperature is now increased by $100^\circ C$, what will be its new angular speed. (given $\alpha_B = 2.0 \times 10^{-5} \text{ per } ^\circ C$)

A. $1.1\omega_0$

B. $1.01\omega_0$

C. $0.996\omega_0$

D. $0.842\omega_0$

Answer: C



Watch Video Solution

108. One mole of an ideal gas undergoes a process

$p = \frac{p_0}{1 + \left(\frac{V_0}{V}\right)^2}$. Here, p_0 and V_0 are constants. Change in

temperature of the gas when volume is changed from $V = V_0$

to $V = 2V_0$ is

A. $-\frac{2p_0 V_0}{5R}$

B. $\frac{11p_0 V_0}{10R}$

C. $-\frac{5p_0 V_0}{4R}$

D. $p_0 V_0$

Answer: B



[Watch Video Solution](#)

109. P-V diagram of a diatomic gas is a straight line passing through origin. The molar heat capacity of the gas in the process will be

A. $4R$

B. $2.5R$

C. $3R$

D. $\frac{4R}{3}$

Answer: C



[Watch Video Solution](#)

110. The root mean square (rms) speed of hydrogen molecules at a certain temperature is 300m/s . If the temperature is doubled and hydrogen gas dissociates into atomic hydrogen the rms speed will become

A. 424.26m/s

B. 300m/s

C. 600m/s

D. 150m/s

Answer: C



Watch Video Solution

111. Volume versus temperature graph of two moles of helium gas is as shown in figure. The ratio of heat absorbed and the work done by the gas in process 1 – 2 is

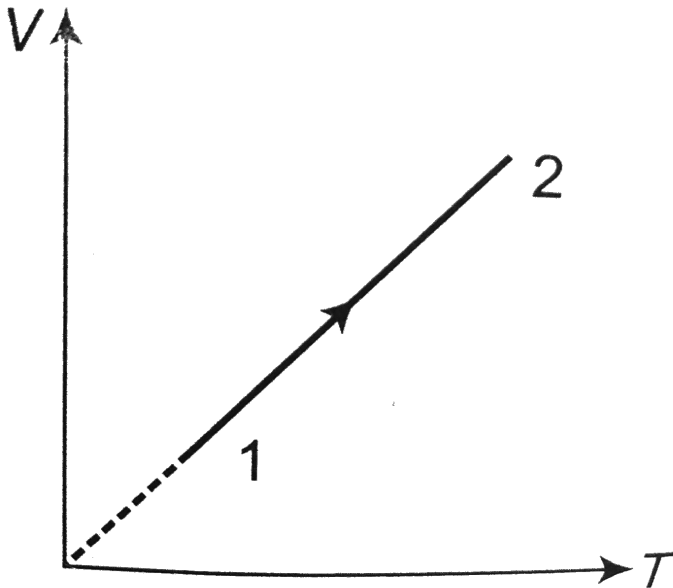

A. 3

B. $5/2$

C. $5/3$

D. $7/2$

Answer: B

 Watch Video Solution

112. Pressure versus temperature graph of an ideal gas is shown in figure. Density of the gas at point A is ρ_0 . Density at B will be

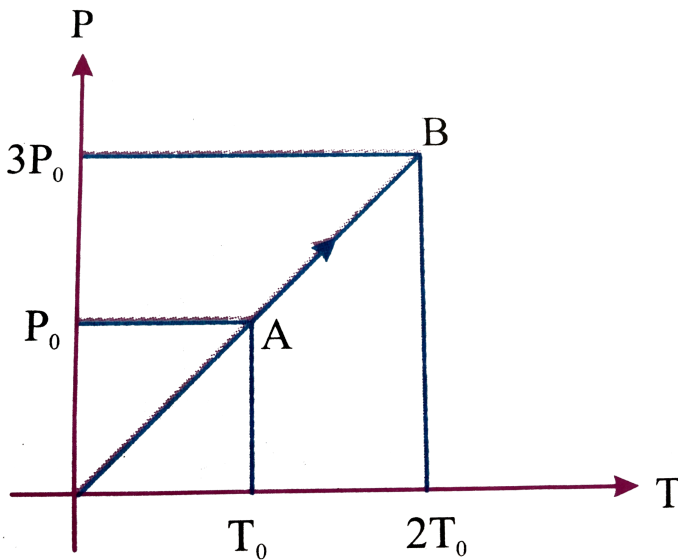

A. $\frac{3}{4}\rho_0$

B. $\frac{3}{2}\rho_0$

C. $\frac{4}{3}\rho_0$

D. $2\rho_0$

Answer: B



[Watch Video Solution](#)

113. Two moles of helium are mixed with n moles of hydrogen.

The root mean square (rms) speed of the gas molecules in the

mixture is $\sqrt{2}$ times the speed of sound in the mixture. Then

value of n is

A. 1

B. 3

C. 2

D. $\frac{3}{2}$

Answer: C



Watch Video Solution

114. Pressure P , Volume V and temperature T of a certain material are related by the $P = \frac{\alpha T^2}{V}$. Here α is constant.

Work done by the material when temperature changes from

T_0 to $2T_0$ while pressure remains constant is :

A. $6\alpha T_0^3$

B. $\frac{3}{2}\alpha T_0^2$

C. $2\alpha T_0^2$

$$D. 3\alpha T_0^2$$

Answer: D

[▶ Watch Video Solution](#)

115. Pressure versus density graph of an ideal gas is shown in figure

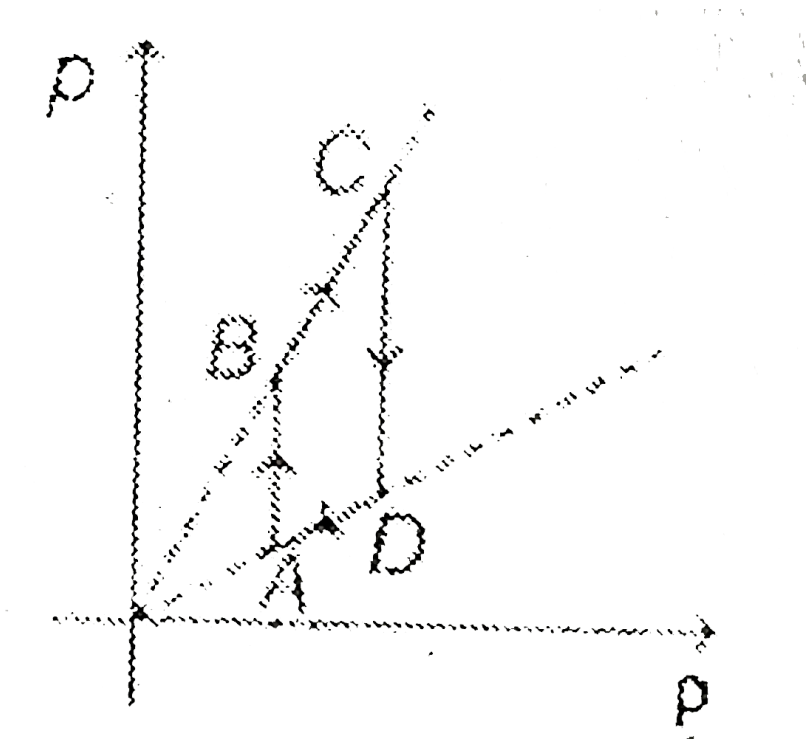

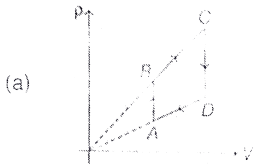

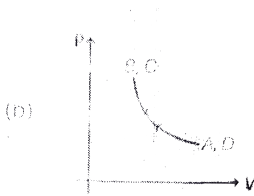

A.

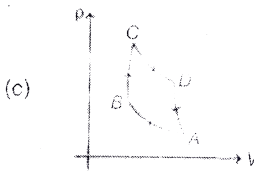

B.



C.

D.  width="30%">

Answer: B

 [Watch Video Solution](#)

116. One end of conducting rod is maintained at temperature $50^{\circ}C$ and at the other end ice is melting at $0^{\circ}C$. The rate of

melting of ice is doubled if:

- A. the temperature is made $200^{\circ}C$ and the area of cross-section of the rod is doubled
- B. the temperature is made $100^{\circ}C$ and length of the rod is made four times
- C. area of cross-section of rod is halved and length doubled
- D. the temperature is made $100^{\circ}C$ and area cross-section of rod and length both are doubled

Answer: D



Watch Video Solution

117. The relation between U , P and V for an ideal gas is $U=2+3PV$. What is the atomicity of the gas.

- A. monoatomic
- B. diatomic
- C. polyatomic
- D. either a monoatomic or diatomic

Answer: C



[Watch Video Solution](#)

118. The specific heats of argon at constant pressure and constant volume are $525J/kg$ and $315J/kg$, respectively. Its density at NTP will be\

A. $0.64\text{kg} / \text{m}^3$

B. $2.62\text{kg} / \text{m}^3$

C. $1.20\text{kg} / \text{m}^3$

D. $1.75\text{kg} / \text{m}^3$

Answer: D



[Watch Video Solution](#)

119. Temperature of 1 mole of an ideal gas is increased from 300K to 310K under isochoric process. Heat supplied to the gas in this process is $Q=25R$, where R =universal gas constant. What amount of work has to be done by the gas if temperature of the gas decreases from 310K to 300K adiabatically?

A. $10 R$

B. $50 R$

C. $25 R$

D. $\frac{25}{2} R$

Answer: C



Watch Video Solution

120. One mole of an ideal monatomic gas at temperature

T_0 expands slowly according to the law $\frac{P}{V} = \text{constant}$ If the

final temperature is $2T_0$, heat supplied to the gas is

A. $2RT_0$

B. $\frac{3}{2}RT_0$

C. RT_0

D. $\frac{1}{2}RT_0$

Answer: A



Watch Video Solution

121. If the ratio of specific heat of a gas at constant pressure to that at constant volume is γ , the change in internal energy of a mass of gas when the volume changes from V to $2V$ at constant pressure p is

A. $\frac{R}{\gamma - 1}$

B. pV

C. $\frac{pV}{\gamma - 1}$

D. $\frac{\gamma p V}{\gamma - 1}$

Answer: C

 Watch Video Solution

122. The figure shows two paths for the change of state of a gas from A to B. The ratio of molar heat capacities in path 1 and path 2 is

15

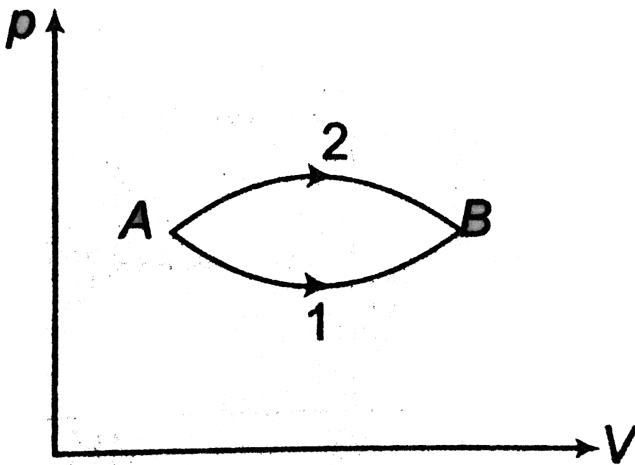

A. > 1

B. < 1

C. 1

D. Data is insufficient

Answer: B



[Watch Video Solution](#)

123. The molar heat capacity in a process of a diatomic gas if it does a work of $\frac{Q}{4}$ when a heat of Q is supplied to it is

A. $\frac{2}{5}R$

B. $\frac{5}{2}R$

C. $\frac{10}{3}R$

D. $\frac{6}{7}R$

Answer: C



Watch Video Solution

124. An insulator container contains 4 moles of an ideal diatomic gas at temperature T . Heat Q is supplied to this gas, due to which 2 moles of the gas are dissociated into atoms but temperature of the gas remains constant. Then

A. $Q = 2RT$

B. $Q = RT$

C. $Q = 3RT$

D. $Q = 4RT$

Answer: B



Watch Video Solution

125. A sample of an ideal gas is taken through the cyclic process $abca$. It absorbs $50J$ of heat during the part ab , no heat during bc and rejects $70J$ of heat during ca . $40J$ of work is done on the gas during the part bc .

(a) Find the internal energy of the gas at b and c if it is $1500J$ at a .

(b) Calculate the work done by the gas during the part ca .

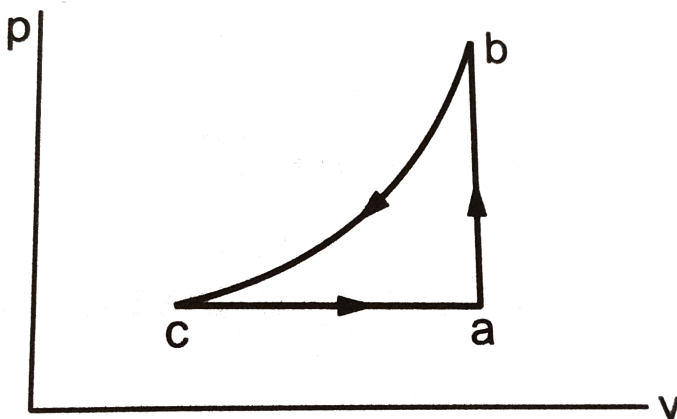

A. 1590 J

B. 1620 J

C. 1540 J

D. 1570 J

Answer: A



Watch Video Solution

126. Ideal monoatomic gas is taken through a process $dQ = 2dU$. Find the molar heat capacity (in terms of R) for the process? (where dQ is heat supplied and dU is change in internal energy)

A. 5 R

B. 3 R

C. R

D. None of these

Answer: B



Watch Video Solution

127. n moles of an ideal monatomic gas undergo a process in which the temperature changes with volume as $T = KV^2$. If the temperature of the gas changes from T_0 to $4T_0$ then

A. $3nRT_0$

B. $(5/2)nRT_0$

C. $(3/2)nRT_0$

D. zero

Answer: C

 Watch Video Solution

128. One mole of a monoatomic ideal gas undergoes the process $A \rightarrow B$ in the given P-V diagram. What is the specific heat for this process?

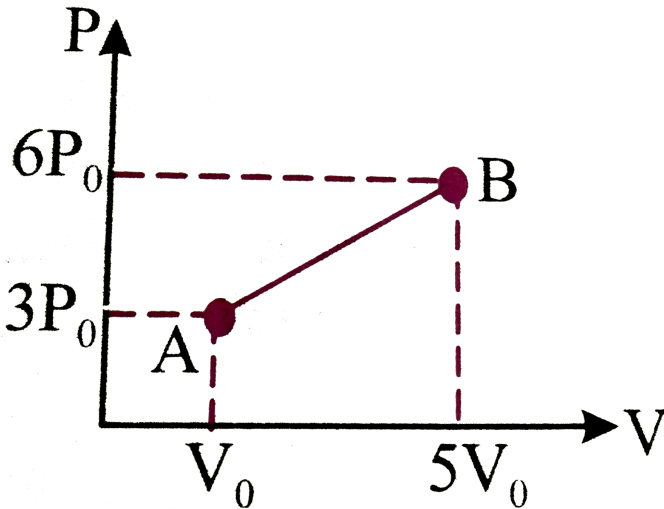

A. $\frac{3R}{2}$

B. $\frac{13R}{6}$

C. $\frac{5R}{2}$

D. $2R$

Answer: B



[Watch Video Solution](#)

129. A monoatomic gas undergoes a process given by $2dU + 3dW = 0$, then what is the process

A. isobaric

B. adiabatic

C. isothermal

D. None of these

Answer: D

 [Watch Video Solution](#)

130. Two sheets of thickness d and $3d$, are touching each other. The temperature just outside the thinner sheet is T_1 and on the side of the thicker sheet is T_3 . The interface temperature is T_2 . T_1, T_2 and T_3 are in arithmetic progression. The ratio of thermal conductivity of thinner sheet to thicker sheet is .

A. 1 : 3

B. 3 : 1

C. 2 : 3

D. 1:9

Answer: A



Watch Video Solution

131. When an ideal diatomic gas is heated at constant pressure, the fraction of the heat energy supplied, which increases the internal energy of the gas, is

A. $\frac{2}{5}$

B. $\frac{3}{5}$

C. $\frac{3}{7}$

D. $\frac{5}{7}$

Answer: D



132. Two metallic spheres S_1 and S_2 are made of the same material and have got identical surface finish. The mass of S_1 is thrice that of S_2 . Both the spheres are heated to the same high temperature and placed in the same room having lower temperature but are thermally insulated from each other. the ratio of the initial rate of cooling of S_1 to that of S_2 is

(a) $\frac{1}{3}$ (b) $\frac{1}{\sqrt{3}}$ (c) $\frac{\sqrt{3}}{1}$ (d) $\left(\frac{1}{3}\right)^{\frac{1}{3}}$

A. $\frac{1}{3}$

B. $\frac{1}{\sqrt{3}}$

C. $\frac{\sqrt{3}}{1}$

D. $\left(\frac{1}{3}\right)^{1/3}$

Answer: D



Watch Video Solution

133. The intensity of radiation emitted by the sun has its maximum value at a wavelength of 510 nm and that emitted by the North star has the maximum value at 350 nm. If these stars behave like black bodies, then the ratio of the surface temperatures of the sun and the north star is

- A. 1.46
- B. 0.69
- C. 1.21
- D. 0.083

Answer: B



Watch Video Solution

134. The average translational kinetic energy of O_2 (molar mass 32) molecules at a particular temperature is $0.048eV$. The translational kinetic energy of N_2 (molar mass 28) molecules in (eV) at the same temperature is (JEE 1997)

(a) 0.0015 (b) 0.003 (c) 0.048 (d) 0.768

A. 0.0015

B. 0.003

C. 0.048

D. 0.768

Answer: C



Watch Video Solution

135. A vessel contains 1 mole of O_2 gas (relative molar mass 32) at a temperature T . The pressure of the gas is P . An identical vessel containing one mole of He gas (relative molar mass 4) at temperature $2T$ has a pressure of

A. $p/8$

B. p

C. $2p$

D. $8p$

Answer: C



Watch Video Solution

136. ρ -T equation of a gas in adiabatic process is given by

A. $T^{\gamma-1}\rho = \text{constant}$

B. $\rho^{\gamma T} = \text{constant}$

C. $T\rho^{1-\gamma} = \text{constant}$

D. $T^{\gamma}\rho^{\gamma-1} = \text{constant}$

Answer: C



Watch Video Solution

137. 10 g of ice at $0^{\circ}C$ is mixed with m mass of water at $50^{\circ}C$.

What is minimum value of m so that ice melts completely. (L =

80 cal/g and $s = 1 \text{ cal/g} \cdot ^{\circ}C$)

A. 32 g

B. 20 g

C. 40 g

D. 16 g

Answer: D



[Watch Video Solution](#)

138. The ends of a copper rod of length 1m and area of cross-section 1cm^2 are maintained at 0°C and 100°C . At the centre of the rod there is a source of heat of power 25 W. Calculate the temperature gradient in the two halves of the rod in steady state. Thermal conductivity of copper is $400\text{Wm}^{-1}\text{K}^{-1}$.

A. $150.50^\circ\text{C}/\text{m}$

B. $325.75^{\circ} C / m$

C. $212.5^{\circ} C / m$

D. $126.25^{\circ} C / m$

Answer: C



Watch Video Solution

139. The heat capacity at constant volume of a monoatomic gas is $35j / K$. Find

(a) the number of moles

(b) the internal energy at $0^{\circ} C$.

(c) the molar heat capacity at constant pressure.

A. TTT

B. TFT

C. FTT

D. FFT

Answer: C



Watch Video Solution

140. One mole of a monoatomic gas at 300K is mixed with two moles of diatomic gas (degree of freedom = 5) at 600K. The temperature of the mixture will be

A. 456 K

B. 531 K

C. 495 K

D. 501 K

Answer: B



Watch Video Solution

141. A vessel of volume $3V$ contains a gas at pressure $4P_0$ and another vessel of volume $2V$ contains same gas at pressure $1.5P_0$. Both vessels have same temperature. When both vessels are connected by a tube of negligible volume, the equilibrium is IP_0 , where I is an integer. Find the value of I .

A. 3.5

B. 3.25

C. 3.75

D. 3

Answer: D



Watch Video Solution

142. In a process $V \propto T^2$, temperature of 2 moles of a gas is increased by 200K. Work done by the gas in this process will be

- A. 600 R
- B. 800 R
- C. 1000 R
- D. 1200 R

Answer: B



Watch Video Solution

143. Choose the correct option:

In following figs. Variation of volume by change of pressure is shown in Fig. A gas is taken along the path $ABCD A$. The change in internal energy of the the gas will be:

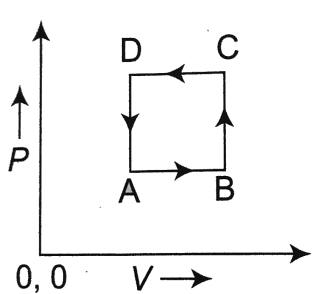

(1)

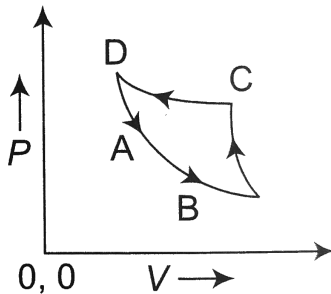

(2)

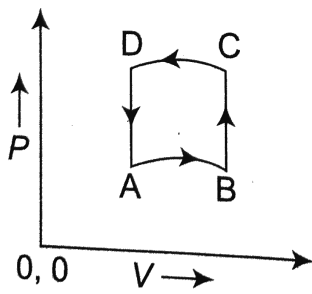

(3)

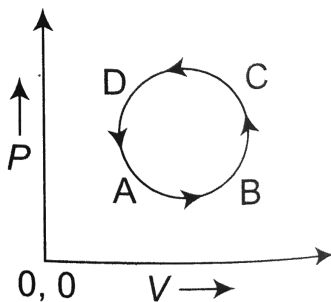

(4)

A. (a) positive in all cases from (1) to (4)

B. (b) positive in cases (1), (2) and (3) but zero in case (4)

C. (c) negative in cases (1), (2) and (3) but zero in case (4)

D. (d) zero in all the four cases.

Answer: D



Watch Video Solution

144. Two samples 1 and 2 are initially kept in the same state. The sample 1 is expanded through an isothermal process where as sample 2 through an adiabatic process upto the same final volume. The final temperature in process 1 and 2 are T_1 and T_2 respectively, then

A. $T_1 > T_2$

B. $T_1 = T_2$

C. $T_1 < T_2$

D. The relation between T_1 and T_2 cannot be deduced

Answer: A



Watch Video Solution

145. two samples 1 and 2 are initially kept in the same state. the sample 1 is expanded through an isothermal process where as sample 2 through an adiabatic process up to the same final volume. Let p_1 and p_2 be the final pressure of the samples and 2 respectively in the previous question then.

A. $p_1 > p_2$

B. $p_1 = p_2$

C. $p_1 < p_2$

D. The relation between p_1 and p_2 cannot be deduced

Answer: A



Watch Video Solution

146. Consider two processes on a system as shown in figure.

The volumes in the initial states are the same in the two processes and the volume in the final states are also the same. Let ΔW_1 and ΔW_2 be the work done by the system in the processes A and B respectively.

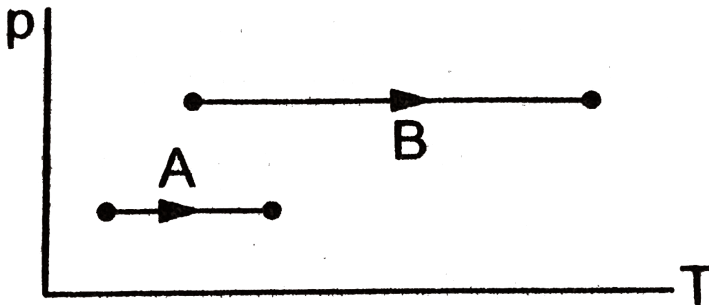

A. $\Delta W_1 > \Delta W_2$

B. $\Delta W_1 = \Delta W_2$

C. $\Delta W_1 < \Delta W_2$

D. The relation between W_1 and W_2 cannot be deduced

Answer: A



Watch Video Solution

147. The molar heat capacity C for an ideal gas going through a given process is given by $C = \frac{a}{T}$, where 'a' is a constant. If $\gamma = \frac{C_p}{C_v}$, the work done by one mole of gas during heating from T_0 to ηT_0 through the given process will be

A. $a \ln(\eta)$

B. $\frac{1}{a \ln(\eta)}$

C. $a \ln(Eta) - \left(\frac{\eta - 1}{\gamma - 1}\right)RT_0$

D. $a \ln(\eta) - (\gamma - 1)RT_0$

Answer: C



Watch Video Solution

148. One mole of an ideal gas undergoes a process in which $T = T_0 + aV^3$, where T_0 and a are positive constants and V is molar volume. The volume for which pressure will be minimum is

A. $\left(\frac{T_0}{2a}\right)^{1/3}$

B. $\left(\frac{T_0}{3a}\right)^{1/3}$

C. $\left(\frac{a}{2T_0}\right)^{2/3}$

D. $\left(\frac{a}{3T_0}\right)^{2/3}$

Answer: A



Watch Video Solution

149. In a certain gas, the ratio of the velocity of sound and root mean square velocity is $\sqrt{5/9}$. The molar heat capacity of the gas in a process given by $PT = \text{constant}$ is.

(Take $R = 2\text{cal/molK}$). Treat the gas as ideal.

A. $\frac{R}{2}$

B. $\frac{3R}{2}$

C. $\frac{5R}{2}$

D. $\frac{7R}{2}$

Answer: D



Watch Video Solution

150. A ring shaped tube contain two ideal gases with equal masses and molar masses $M_1 = 32$ and $M_2 = 28$.

The gases are separated by one fixed partition P and another movable stopper S which can move freely without friction inside the ring. The angle α as shown in the figure is degrees.

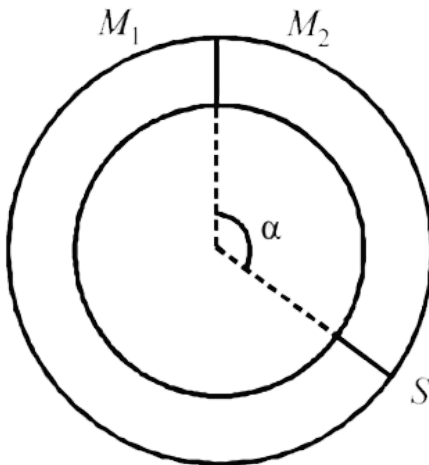

A. $\frac{7\pi}{8}$

B. $\frac{8\pi}{7}$

C. $\frac{15\pi}{16}$

D. $\frac{16\pi}{15}$

Answer: D



Watch Video Solution

151. One mole of an ideal gas at temperature T expands slowly according to the law $\frac{p}{V} = \text{constant}$.

Its final temperature is T_2 . The work done by the gas is

A. $R(T_2 - T_1)$

B. $2R(T_2 - T_1)$

C. $\frac{R}{2}(T_2 - T_1)$

D. $\frac{2R}{3}(T_2 - T_1)$

Answer: C



Watch Video Solution

152. One mole of an ideal gas is kept enclosed under a light piston (area = $10^{-1}m^2$) connected by a compressed spring (spring constant 100 N/m). The volume of gas is $0.83m^3$ and its temperature is 100K. The gas is heated so that it compresses the spring further by $0.1m$. The work done by the gas in the process is : (Take $R = 8.3J/K\text{-mole}$ and suppose there

is no atmosphere).

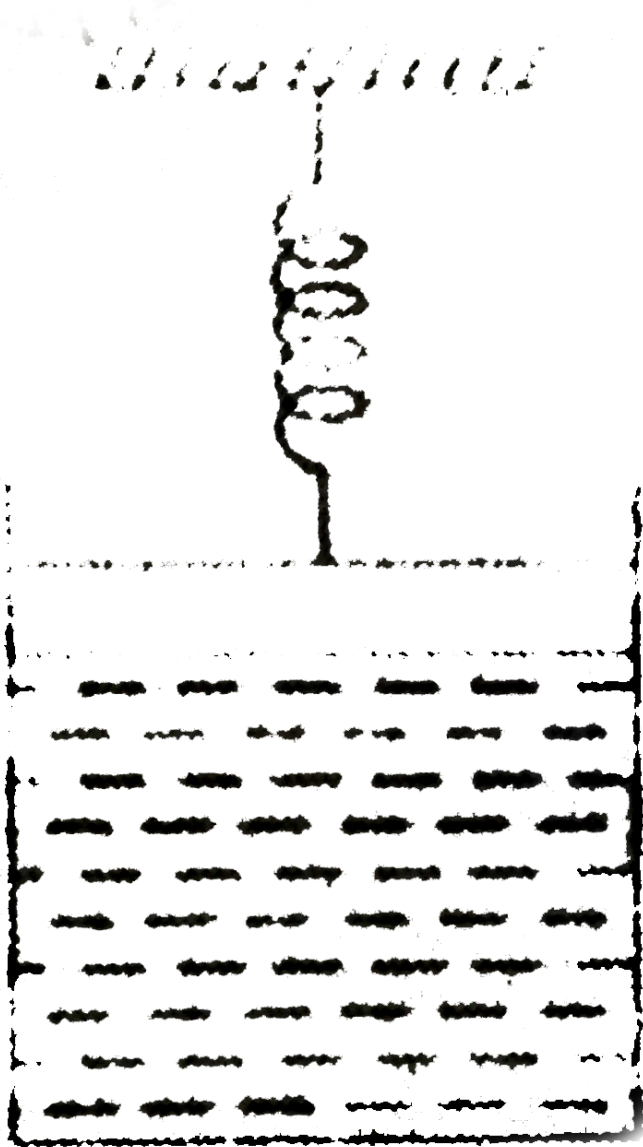

A. 3 J

B. 6 J

C. 9 J

D. 10.5 J

Answer: D



Watch Video Solution

153. A boiler is made of a copper plate 2.4mm thick with an inside coating of a 0.2mm thick layer of tin. The surface area exposed to gases at 700°C is 400cm^2 . The maximum amount of steam that could be generated per hour at atmospheric pressure is

$$\left(\begin{array}{l} K_{cu} = 0.9\text{cal/cm} \cdot \text{s}^{-1} \text{ \& } k_{tin} = 0.15\text{cal/cm}^2/\text{s}^\circ\text{C} \\ \text{and } L_{steam} = 540\text{cal/g} \end{array} \right).$$

A. 5000 kg

B. 1000 kg

C. 4000 kg

D. 200 kg

Answer: C



Watch Video Solution

154. Two thin metallic spherical shells of radii r_1 and r_2 ($r_1 < r_2$) are placed with their centres coinciding. A material of thermal conductivity K is filled in the space between the shells. The inner shells is maintained at temperature θ_1 and the outer shell at temperature θ_2 ($\theta_1 < \theta_2$). Calculate the rate

at which heat flows radially through the material.

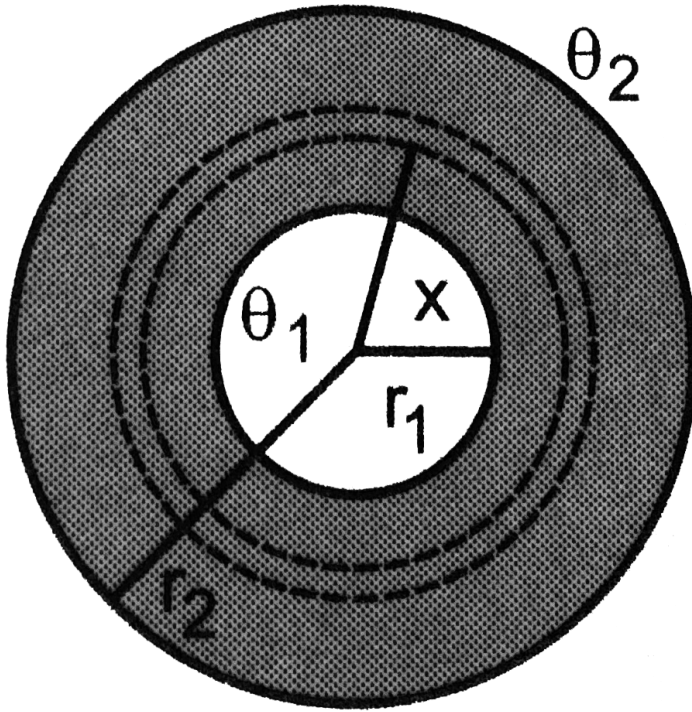

[▶ Watch Video Solution](#)

155. A sphere of diameter 7cm and mass 266.5g floats in a bath of liquid. As the temperature is raised, the sphere just sinks at a temperature of 35°C . If the density of the liquid at

$0^\circ C$ is $1.527g/cm^3$, find the coefficient of cubical expansion of the liquid. ignore expansion of sphere.

A. $9.52 \times 10^{-4} \text{ per } ^\circ C$

B. $6.23 \times 10^{-5} \text{ per } ^\circ C$

C. $8.486 \times 10^{-6} \text{ per } ^\circ C$

D. $4.12 \times 10^{-3} \text{ per } ^\circ C$

Answer: A



[Watch Video Solution](#)

156. The graph shown in the figure represents change in the temperature of 5 kg of a substance as it absorbs heat at a constant rate of 42 kJ min^{-1} . The latent heat of vaporization of

the substance is :

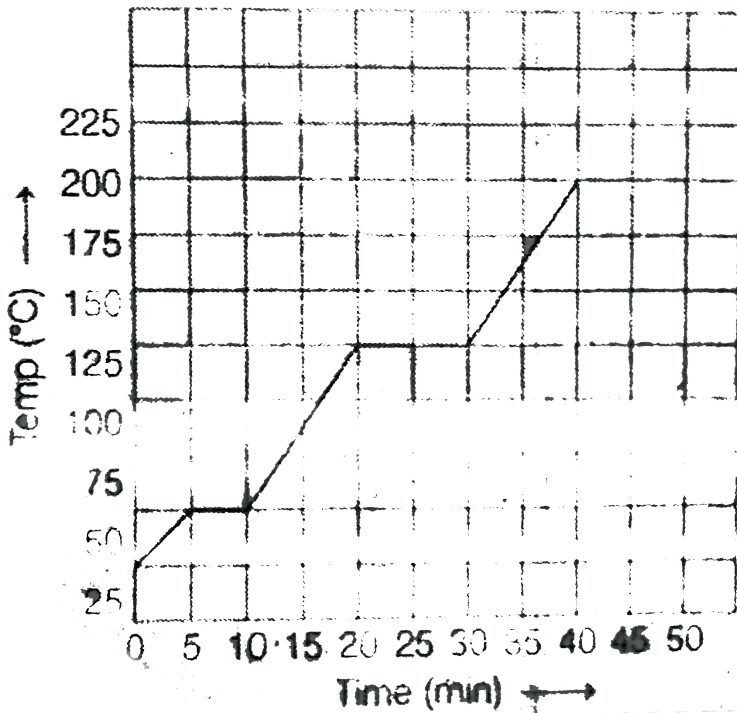

- A. 96kJ kg^{-1}
- B. 126kJ kg^{-1}
- C. 84kJ kg^{-1}
- D. 12.6kJ kg^{-1}

Answer: C

 [Watch Video Solution](#)

157. The density of a material A is $1500\text{kg}/\text{m}^3$ and that of another material B is $2000\text{kg}/\text{m}^3$. It is found that the heat capacity of 8 volumes of A is equal to heat capacity of 12 volumes of B. The ratio of specific heats of A and B will be

A. 1 : 2

B. 3 : 1

C. 3 : 2

D. 2 : 1

Answer: D

 [Watch Video Solution](#)

158. Three identical rods AB, CD and PQ are joined as shown. P and Q are mid point of AB and CD respectively. Ends A, B, C and D are maintained at $0^{\circ}C$, $100^{\circ}C$, $30^{\circ}C$ and $60^{\circ}C$ respectively. The direction of heat flow in PQ is

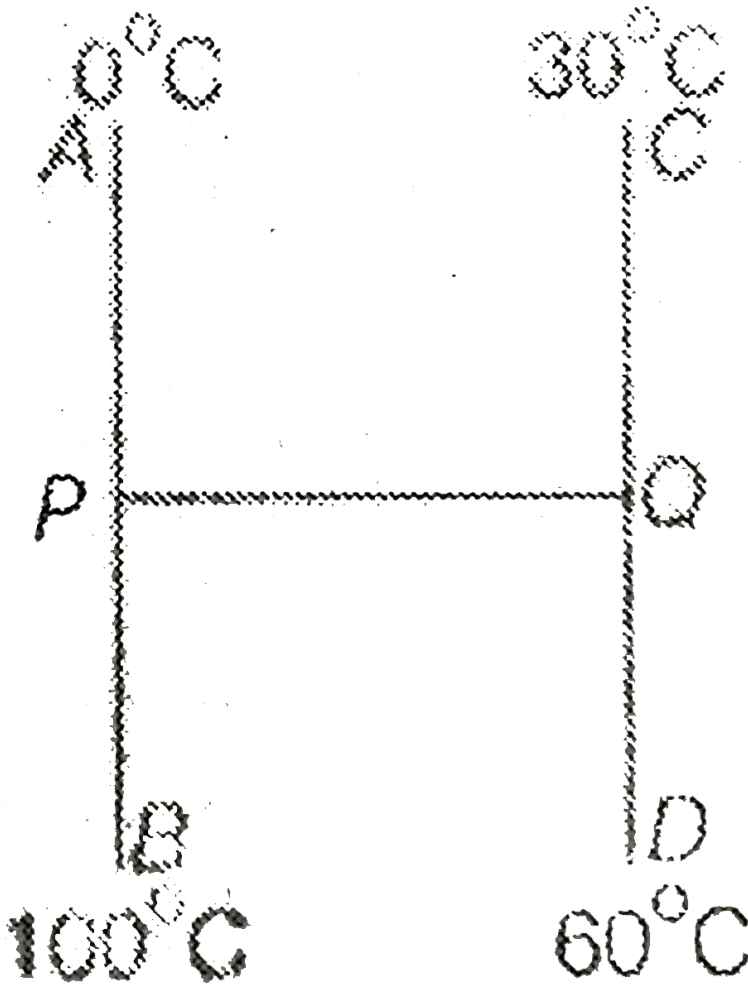

A. from P to Q

B. from Q to P

C. heat does not flow in PQ

D. data is sufficient

Answer: A



[Watch Video Solution](#)

159. Spheres P and Q are uniformly constructed from the same material which is good conductor of heat and the radius of Q is thrice the radius of P . The rate of fall of temperature of P is x times that of Q when both are at the same surface temperature. Find the value of ' x ' :

A. 27

B. 1

C. 3

D. 9

Answer: C



Watch Video Solution

160. A container X has volume double that of container Y and both are connected by a thin tube. Both contains same ideal gas. The temperature of X is 200K and that of Y is 400K. If mass of gas in X is m then in Y it will be.

A. $m/8$

B. $m/6$

C. $m/4$

D. $m/2$

Answer: C



Watch Video Solution

161. A given mass of a gas expands from a state A to the state B by three paths 1, 2 and 3 as shown in T-V indicator diagram. If W_1 , W_2 and W_3 respectively be the work done by the gas

along the three paths, then

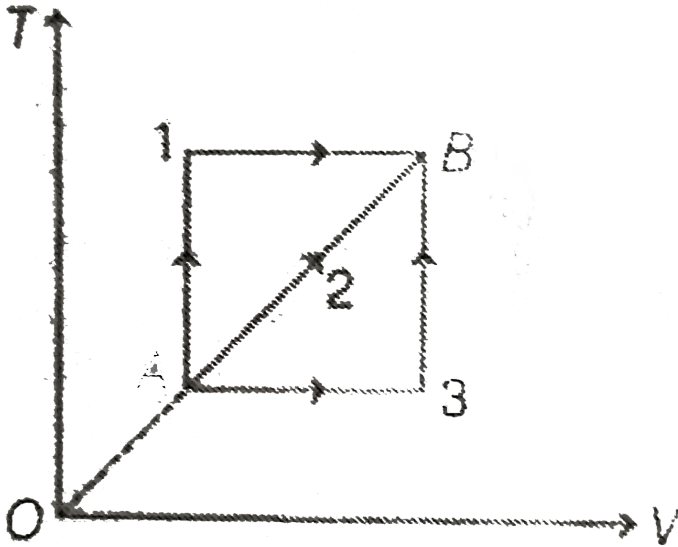

- A. A) $W_1 > W_2 > W_3$
- B. B) $W_1 < W_2 < W_3$
- C. C) $W_1 = W_2 = W_3$
- D. D) $W_1 < W_2, W_1 > W_3$

Answer: A



Watch Video Solution

162. The figure shows the graph of logarithmic reading of pressure and volume for two ideal gases A and B undergoing adiabatic process. From figure, it can be concluded that

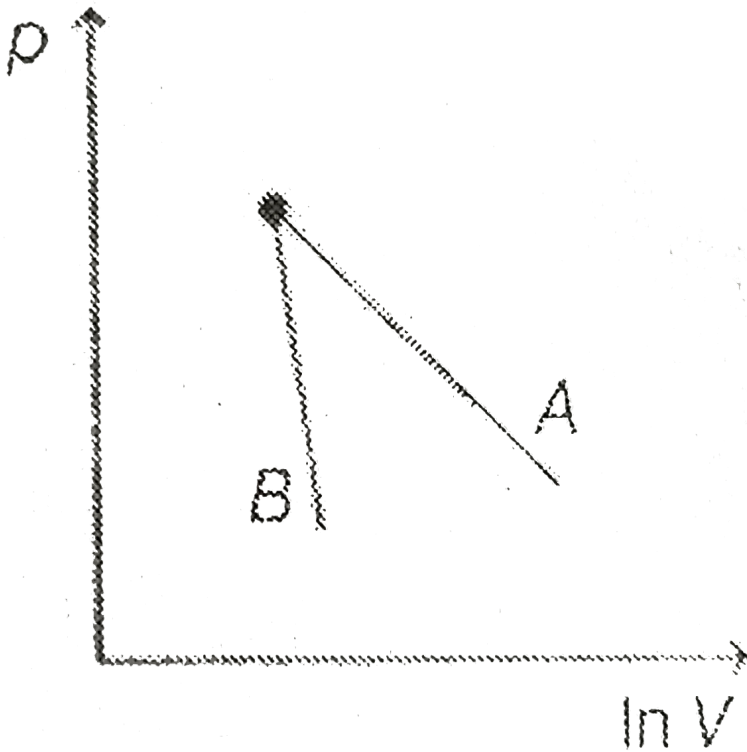

- A. gas B is diatomic
- B. gas A and B both are diatomic
- C. gas A is monoatomic

D. gas B is monoatomic and gas A is diatomic

Answer: D

 Watch Video Solution

163. An ideal monoatomic gas is carried around the cycle ABCDA as shown in the figure. The efficiency of the cycle is

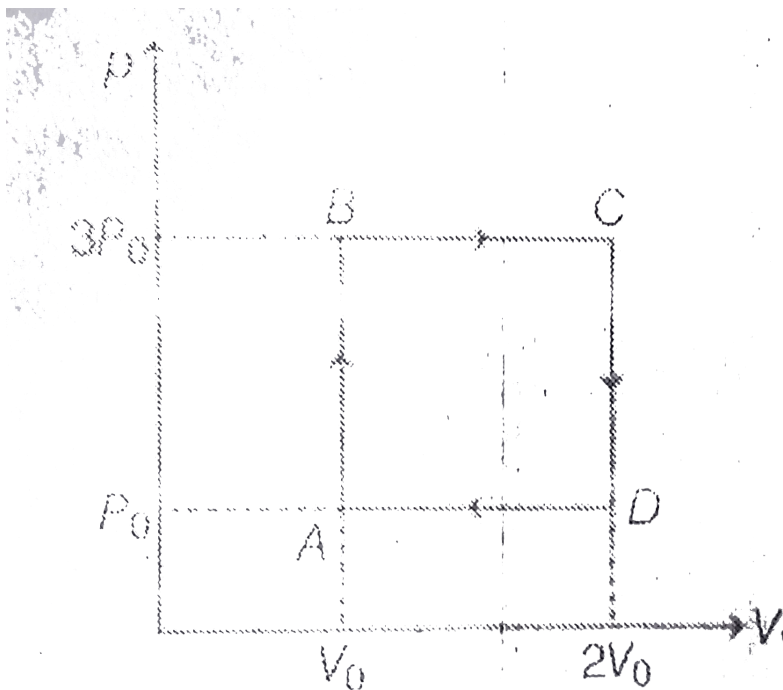

ItBrgt

A. 28.6 %

B. 34.2 %

C. 46.8 %

D. 62.3 %

Answer: A



Watch Video Solution

164. In a thermodynamic process, pressure of a fixed mass of gas is changed in such manner that the gas releases 30 joule of heat and 18 joule of work was done on the gas. If the initial internal energy of the gas was 60 joule, then the final internal energy is $8x$ joule. find the value of x

A. 32 joule

B. 48 joule

C. 72 joule

D. 96 joule

Answer: B



Watch Video Solution

165. The relation between U , p and V for an ideal gas in an adiabatic process is given by relation $U = a + bpV$. Find the value of adiabatic exponent (γ) of this gas.

A. $\frac{b + 1}{b}$

B. $\frac{b + 1}{a}$

C. $\frac{a + 1}{b}$

D. $\frac{a}{a+b}$

Answer: A



Watch Video Solution

166. A thermal insulated vessel contains some water at $0^\circ C$. The vessel is connected to a vacuum pump to pump out water vapour. This results in some water getting frozen. It is given latent heat of vaporization of water at $0^\circ C = 21 \times 10^5 J/kg$ and latent heat of freezing of water $= 3.36 \times 10^5 J/kg$. the maximum percentage amount of water vapour that will be solidified in this manner will be:

A. 86.2 %

B. 33.6 %

C. 21 %

D. 24.36 %

Answer: A



Watch Video Solution

167. The temperature drop through each layer of a two layer furnace wall is shown in Assume that the external temperature T_{10} and T_3 are maintained constant and $T_1 > T_3$ If the thickness of the layers x_1 and x_2 are the same

which of the following statements are correct

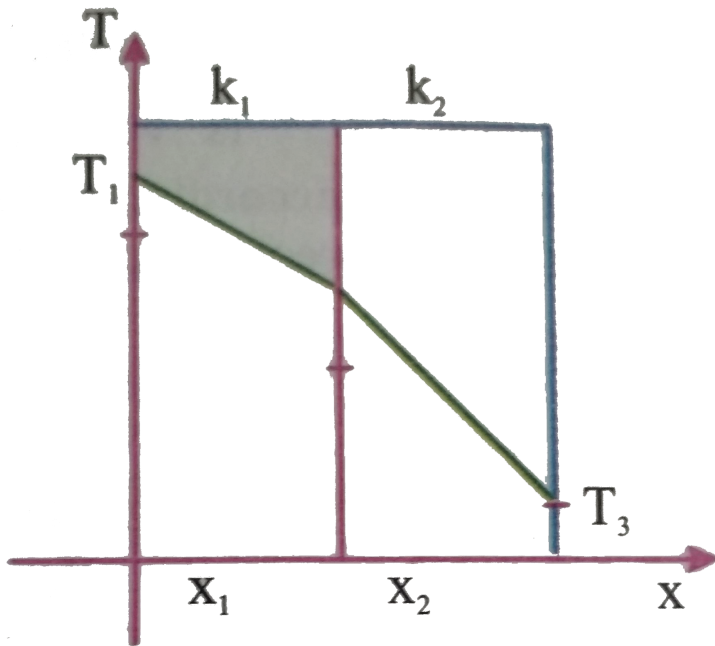

A. $k_1 > k_2$

B. $k_1 < k_2$

C. $k_1 = k_2$ but heat flow through material (1) is larger than through (2)

D. $k_1 = k_2$ but heat flow through material (1) is less than that through (2)

Answer: A



Watch Video Solution

168. Three different arrangements of materials 1 and 2, 3 to form a wall. Thermal conductivities are $k_1 > k_2 > k_3$. The left side of the wall is $20^\circ C$ higher than the right side. Temperature difference ΔT across the material 1 has following relation in three cases

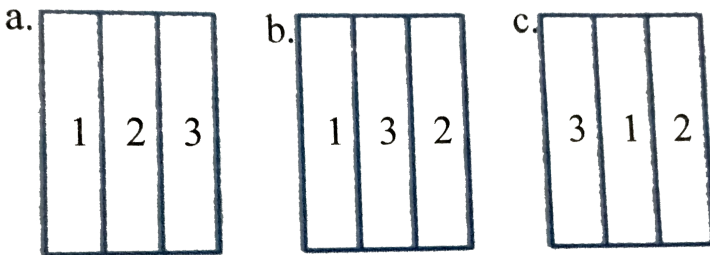

A. $\Delta T_a > \Delta T_b > \Delta T_c$

B. $\Delta T_a = \Delta T_b = \Delta T_c$

C. $\Delta T_a = \Delta T_b > \Delta T_c$

D. $\Delta T_a = \Delta T_b < \Delta T_c$

Answer: B

 Watch Video Solution

169. On a pT diagram, a cyclic process is performed as shown.

Where is the volume maximum?

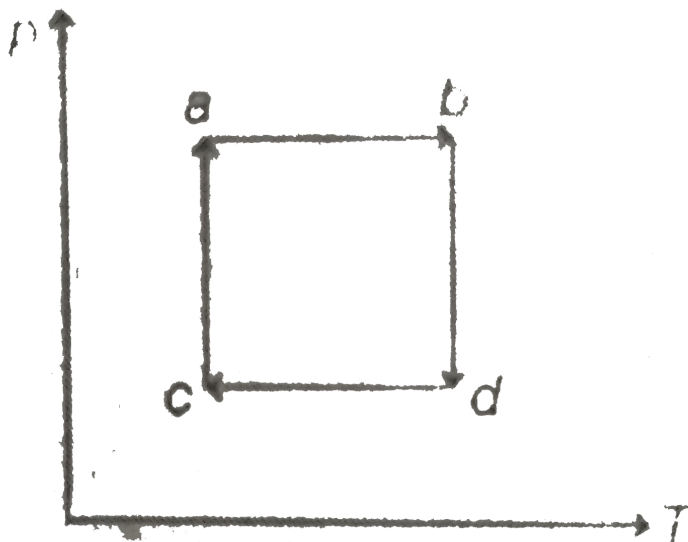

A. a

B. b

C. c

D. d

Answer: D



Watch Video Solution

170. A monoatomic ideal is used as the working substance for the carnot cycle shown in the figure. Processes AB and CD are isothermal, while processes BC and DA are adiabatic. During process AB, 400 J of work is done by the gas on the surroundings. How much heat is expelled by the gas during

process CD?

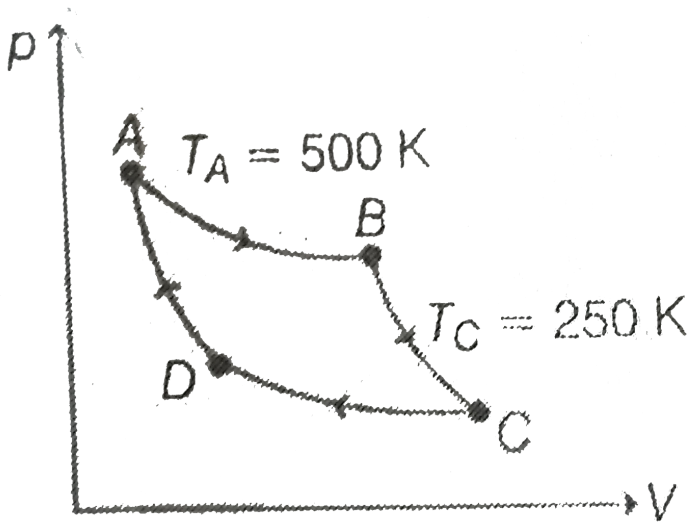

A. 1600 J

B. 400 J

C. 200 J

D. 100 J

Answer: C



Watch Video Solution

171. Figure illustrates a cycle conducted with n moles of an ideal gas. In the states a and b the gas temperatures are T_a and T_b respectively. Temperature of the gas in the state C is

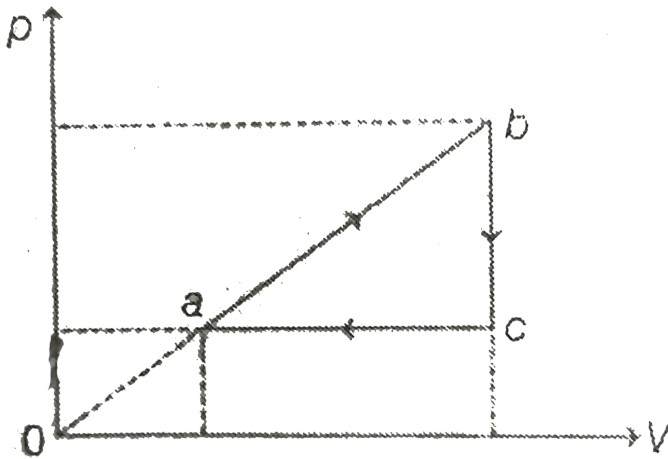

It is

A. $\sqrt{T_a T_b}$

B. $T_a + T_b$

C. $\frac{T_a T_b}{T_a + T_b}$

D. $(T_a + T_b) / 2$

Answer: A



Watch Video Solution

172. One mole of a diatomic gas undergoes a process $P = P_0 / [1 + (V/V_0)^3]$ where P_0 and V_0 are constant. The translational kinetic energy of the gas when $V = V_0$ is given by

A. $\frac{5p_0 V_0}{4}$

B. $\frac{3p_0 V_0}{4}$

C. $\frac{3p_0 V_0}{2}$

D. $\frac{5p_0 V_0}{2}$

Answer: B



Watch Video Solution

173. 3 moles of an ideal mono atomic gas performs a cycle as shown in fig. If gas temperature $T_A = 400K$, $T_B = 800K$, $T_C = 2400K$, and $T_D = 1200K$. Then total work done by gas is

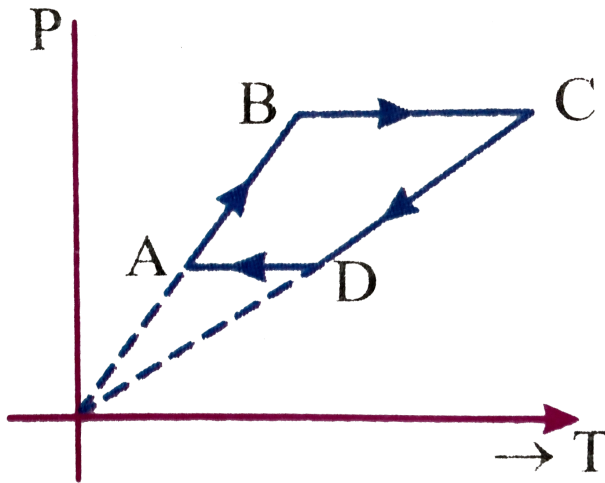

- A. 19.94kJ
- B. 22.65KJ
- C. 15.81kJ
- D. 10.37kJ

Answer: A

 Watch Video Solution

174. Given T-p curve for three processes. Work done in process 1, 2 and 3 (if initial and final pressure are same for all processes) is W_1 , W_2 and W_3 respectively. Correct order is

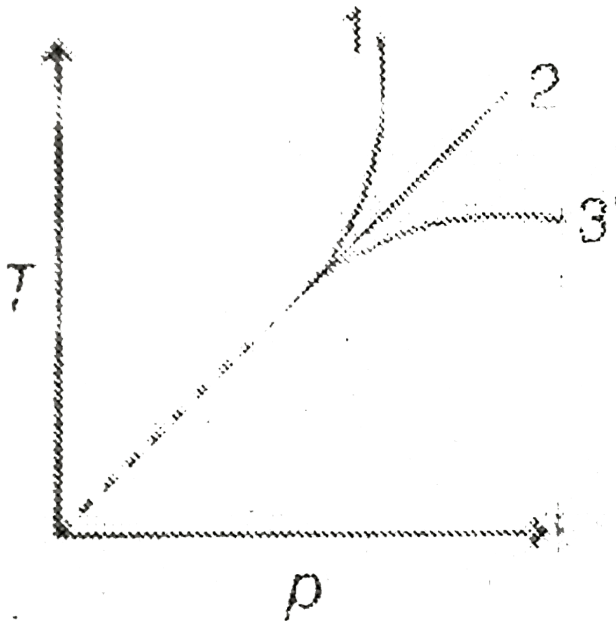

A. $W_1 < W_2 > W_3$

B. $W_1 > W_2 > W_3$

C. $W_1 < W_2 < W_3$

D. $W_1 = W_2 = W_3$

Answer: B



Watch Video Solution

175. Figure shows two flasks connected to each other. The volume of the flask 1 is twice that of flask 2. The system is filled with an ideal gas at temperature $100K$ and $200K$ respectively. If the mass of the gas in 1 be m then what is the mass of the

gas in flask 2

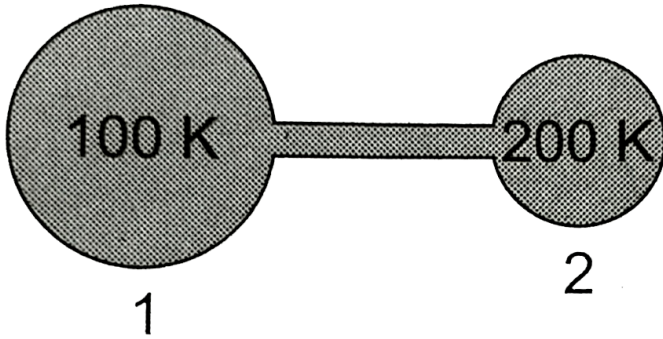

A. m

B. $\frac{m}{4}$

C. $\frac{m}{2}$

D. $2m$

Answer: C



Watch Video Solution

176. A cylinder piston of mass M slides smoothly inside a long cylinder closed at one end and enclosing a certain mass of gas. The cylinder is kept with its axis horizontal. If the piston is displaced from its equilibrium position, it oscillates simple harmonically. The period of oscillation will be

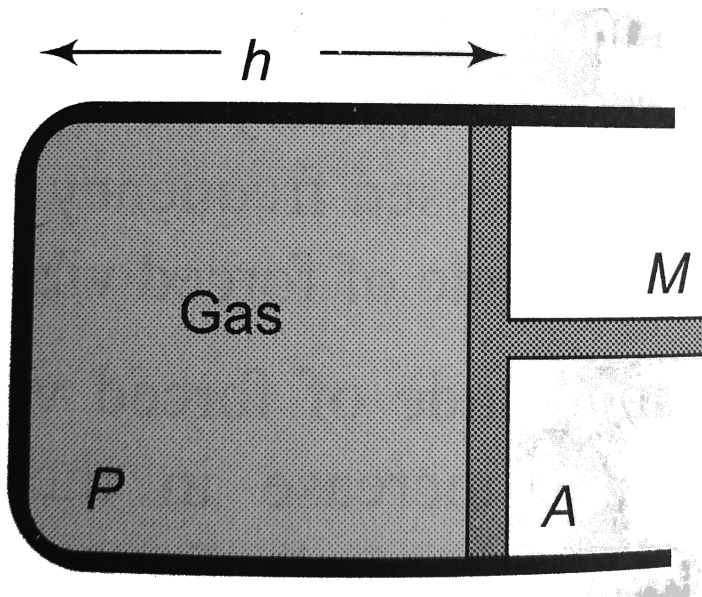

A. $T = 2\pi \sqrt{\left(\frac{Mh}{pA}\right)}$

B. $2\pi \sqrt{\frac{Mh}{pA}}$

$$C. T = 2\pi \sqrt{\left(\frac{M}{pAh}\right)}$$

$$D. T = 2\pi \sqrt{MphA}$$

Answer: A

 [Watch Video Solution](#)

177. A 1-L flask contains some mercury. It is found that at different temperature, the volume of air inside the flask remains the same. What is the volume of mercury in the flask, given that the coefficient of linear expansion of glass $= 9 \times 10^{-6} / ^\circ C$ and the coefficient of volume expansion of $Hg = 1.8 \times 10^{-4} / ^\circ C$?

A. a. 50 cm^3

B. b. 100 cm^3

C. c. 150 cm^3

D. d. 200 cm^3

Answer: C



Watch Video Solution

178. A point source of heat of power P is placed at the centre of a spherical shell of mean radius R . The material of the shell has thermal conductivity K . Calculate the thickness of the shell if temperature difference between the outer and inner surfaces of the shell in steady state is T .

A. $\frac{2\pi R^2 KT}{P}$

B. $\frac{4\pi R^2 KT}{P}$

C. $\frac{\pi R^2 KT}{P}$

D. $\frac{\pi R^2 KT}{4P}$

Answer: B



Watch Video Solution

179. A fixed chamber isolated from surrounding is divided into equal halves A and B as shown in figure. Part A contains one mole of oxygen and part B contains one mole of helium. The separator C is thermally conducting and kept fixed. Initial temperature of oxygen chamber is 600 K and that of helium 300 K. Specific heat capacity of separator and chamber is

negligible. Choose the correct statement.

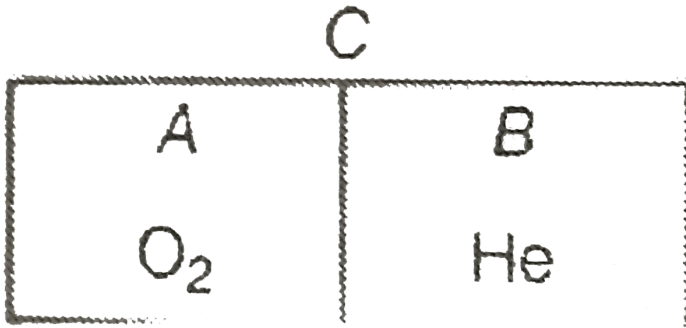

A. change in temperature of helium gas is equal to change in temperature of oxygen gas

B. change in internal energy of helium gas is equal to 200

R

C. temperature of oxygen gas in steady state condition is 487 K (approximately)

D. All of the above

Answer: C



180. Figure shows the VT diagram for helium gas in a cyclic process. Find the ratio of maximum and minimum pressure.

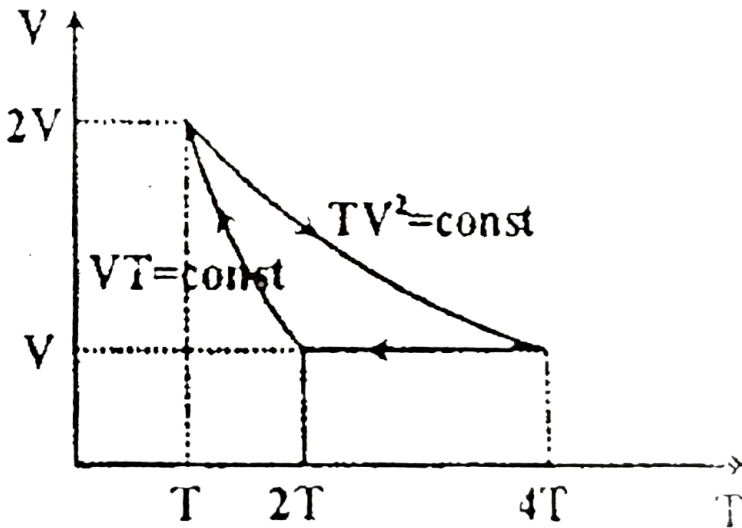

A. 2

B. 4

C. 6

D. 8

Answer: D



Watch Video Solution

181. The state of an ideal gas is changed through an isothermal process at temperature T_0 as shown in figure. The work done by the gas in going from state B to C is double the work done by gas in going from state A to B. If the pressure in

the state B is $\frac{p_0}{2}$, then the pressure of the gas in state C is

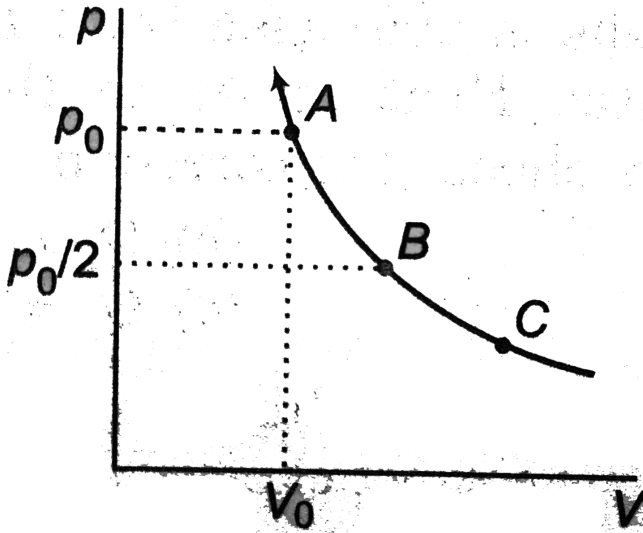

A. $p_0/2$

B. $p_0/4$

C. $p_0/6$

D. $p_0/8$

Answer: D



Watch Video Solution

182. An ideal gas undergoes a process in which co-efficient of volume expansion of gas γ , varies with absolute temperature by the relation $\gamma = \frac{2}{T}$. Let C is molar heat capacity in this process and C_p, C_V are molar heat capacities at constant pressure and volume respectively. Then

A. $C = 3C_V + 2R$

B. $C = 2C_V + 2R$

C. $C = C_V + 2R$

D. $C = C_V - R$

Answer: C



Watch Video Solution

183. A solid body X of very large heat capacity is kept in an atmosphere whose temperature is 300 K. The body X is connected to a rod of length 1 m and cross sectional area S, as shown in the figure. Thermal conductivity of rod AB is 0.0567 W/mK . Assuming that there is no heat exchange with the surrounding except from the end B of the rod i.e., neither by any surface of X nor by the curved surface of rod. The end B has emissivity $e = 0.8$. If the steady state temperature of the end B is 400 K then find the temperature of X in steady state. (Stefan constant $\sigma = 5.67 \times 10^{-8} \text{ W/m}^2 \text{ K}^4$)

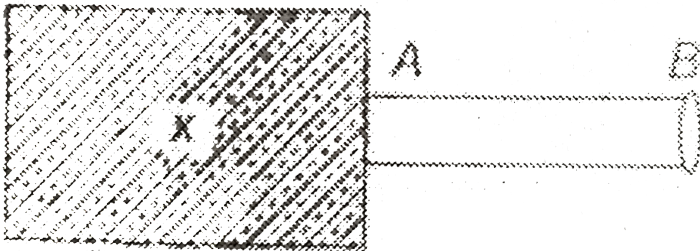

A. 14400 K

B. 12600 K

C. 13000 K

D. 12000 K

Answer: A



[Watch Video Solution](#)

184. A black body emits radiation at the rate P when its temperature is T . At this temperature the wavelength at which the radiation has maximum intensity is λ_0 , If at another temperature T' the power radiated is P' and wavelength at maximum intensity is $\frac{\lambda_0}{2}$ then

A. $P'T'=32PT$

B. $P'T'=16PT$

C. P'T'=8PT

D. P'T'=4PT

Answer: A



Watch Video Solution

185. Where does a body weigh more – at the surface of the earth or in a mine?

A. (a) $\frac{1}{4}$

B. (b) $\frac{1}{3}$

C. (c) $\frac{1}{2}$

D. (d) $\frac{1}{5}$

Answer: B



Watch Video Solution

186. A vertical cylinder of cross-section area A contains one mole of an ideal mono-atomic gas under a piston of mass M . At a certain instant a heater which supplies heat at the rate q J/s is switched *ON* under the piston. The velocity with which the piston moves upward under the condition that pressure of gas remains constant is [Assume no heat transfer through

walls of cylinder]

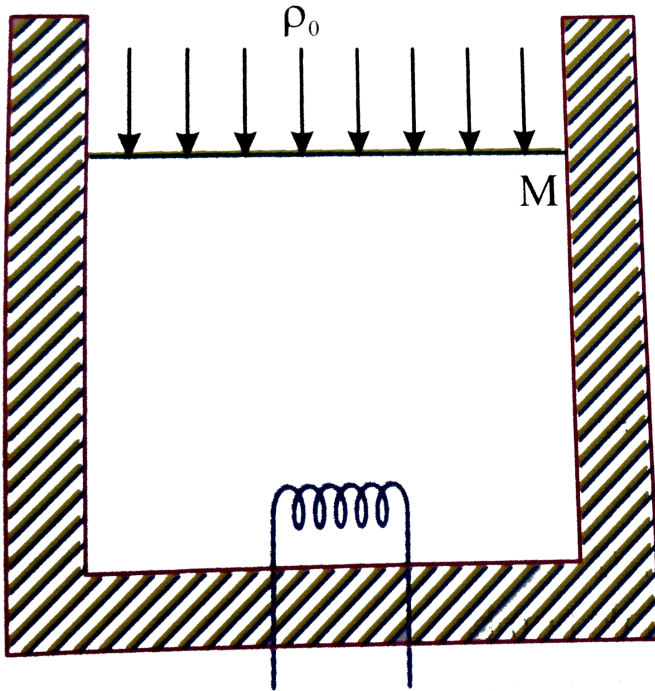

A. (a) $v = \frac{2}{9} \frac{q}{p_0 A + Mg}$

B. (b) $v = \frac{2}{5} \frac{q}{p_0 A + Mg}$

C. (c) $v = \frac{2q}{3p_0 A + Mg}$

D. (d) $v = \frac{2q}{5p_0 A + 3Mg}$

Answer: B



Watch Video Solution

B. More than one option is correct

1. Two spheres A and B have radius but the heat capacity of A is greater than that of B. The surfaces of both are painted black. They are heated to the same temperature and allowed to cool. Then initially

A. A cools faster than B

B. both A and B cool at the same rate

C. at any common temperature, the ratio of their rates of cooling is a constant

D. B cools faster than A

Answer: C::D

 [Watch Video Solution](#)

2. A thermally insulated chamber of volume $2V_0$ is divided by a frictionless piston of area S into two equal part A and B . Part A has an ideal gas at pressrue P_0 and temperature T_0 and part B is vacuum. A massless spring of force constant K is connected with the piston and the wall of the container as shown. Initially the spring is unstretched. The gas inside chamber A is allowed to expand. Let in equilibrium the spring

be compressed by x_0 . Then

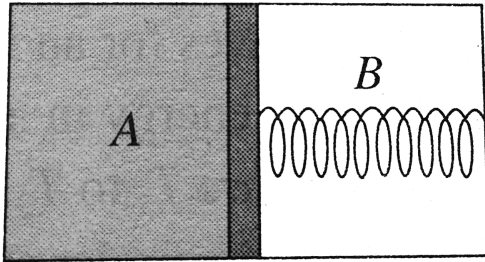

A. final pressure of the gas is $\frac{kX_0}{S}$

B. work done by the gas is $\frac{1}{2}kX_0^2$

C. change in internal energy of the gas is $\frac{1}{2}kX_0^2$

D. temperature of the gas is decreased

Answer: A::B::C::D



Watch Video Solution

3. Choose the correct option:

In the arrangement shown in Fig. gas is thermally insulated.

An ideal gas is filled in the cylinder having pressure P_0 (gt

atmospheric pressure P_a). The spring of force constant K is

initially un-stretched. The piston of mass m and area S is

frictionless. In equilibrium, the piston rises up by distance x_0 ,

then

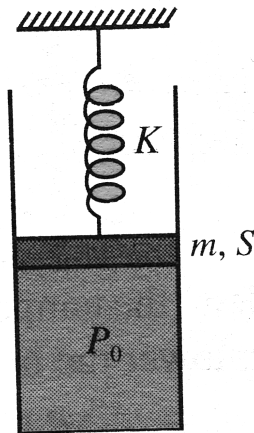

A. (a) final pressure of the gas is $p_a + \frac{kX_0}{S} + \frac{mg}{S}$

B. (b) work done by the gas is $\frac{1}{2}kX_0^2 + mgX_0$

C. (c) decrease in internal energy of the gas is

$$\frac{1}{2}KX_0^2 + mgX_0 + p_a Sx_0$$

D. (d) work done by the gas is $\frac{1}{2}kX_0^2$

Answer: A::C

 [Watch Video Solution](#)

4. $P - V$ diagram of a cyclic process $ABCA$ is as shown in

Fig. Choose the correct alternative

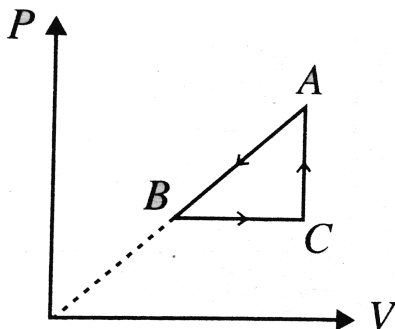

$$(A) \Delta Q_{A \rightarrow B} = \text{negative} \quad (B) \Delta U_{B \rightarrow C} = \text{positive} \quad (C)$$

$$\Delta U_{C \rightarrow A} = \text{negative} \quad (D) \Delta W_{CAB} = \text{negative}$$

A. $\Delta Q_{A \rightarrow B} = \text{negative}$

B. $\Delta U_{B \rightarrow C} = \text{positive}$

C. $\Delta U_{C \rightarrow A} = \text{negative}$

D. $\Delta W_{CAB} = \text{negative}$

Answer: A::B::D

 [Watch Video Solution](#)

5. A gas undergoes change in its state from position A to position B via three different path as shown in Fig. Select the correct alternatives :

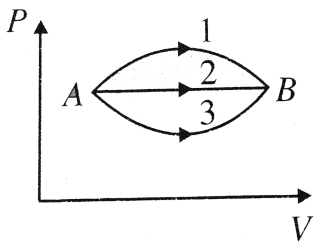

- (A) Change in internal energy in all the three paths is equal
- (B) In all the three paths heat is absorbed by the gas
- (C) Heat absorbed/released by the gas is maximum in path 1
- (D) Temperature of the gas first increases and then decreases in path 1
-
- A. Change in internal energy in all the three paths is equal
- B. In all the three paths heat is absorbed by the gas
- C. Heat absorbed/released by the gas is maximum in path 1
- D. Temperature of the gas first increases and then decreases in path 1

Answer: A::B::C



Watch Video Solution

6. Consider the quantity $\frac{MkT}{pV}$ of an ideal gas where M is the mass of the gas. It depends on the

- A. temperature of the gas
- B. volume of the gas
- C. pressure of the gas
- D. nature of the gas

Answer: C::D



Watch Video Solution

7. Which of the following quantities is independent of the nature of the gas at same temperature ?

- A. The number of molecules in 1 mole
- B. The number of molecules in equal volume
- C. The translational kinetic energy of 1 mole
- D. The kinetic energy of unit mass

Answer: A:C

 [Watch Video Solution](#)

8. Which of the following quantities depend on temperature only for a given ideal gas ?

- A. (a) Total internal energy of the gas

B. (b) Product pV of the gas

C. (c) The ratio of pressure and density of the gas

D. (d) Root mean square speed of the gas

Answer: C::D

 [Watch Video Solution](#)

9. During the process AB of an ideal gas

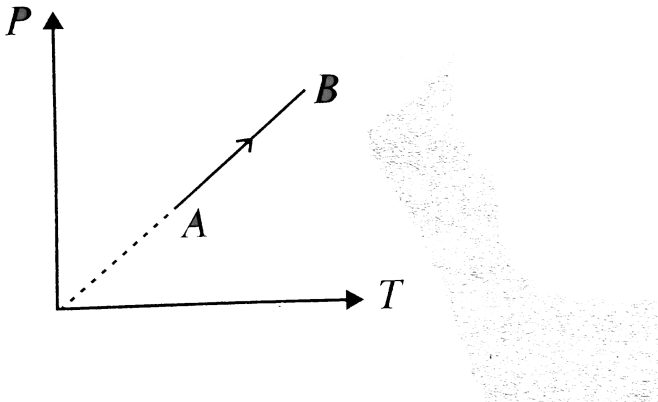

- A. work done on the gas is zero
- B. density of the gas is constant
- C. slope of line AB from the T-axis is inversely proportional to the number of moles of the gas
- D. slope of line AB from the T-axis is directly proportional to the number of moles of the gas

Answer: A::B::D

 [Watch Video Solution](#)

10. Temperature versus pressure graph of an ideal gas is shown in Fig. During the process AB

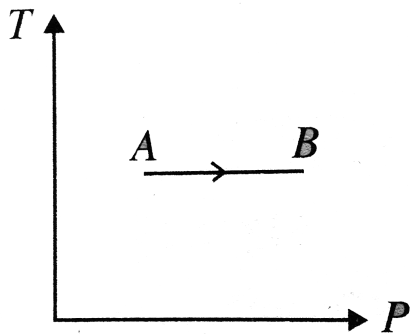

- A. internal energy of the gas remains constant
- B. volume of the gas increased
- C. work done on the gas is positive
- D. pressure is inversely proportional to volume

Answer: A::C::D

 [Watch Video Solution](#)

11. Internal energy of an ideal diatomic gas at 300 K is 100 J. In this 100 J

- A. potential energy = 0
- B. rotational kinetic energy = 40 J
- C. translational kinetic energy = 60 J
- D. translational kinetic energy is 100 J

Answer: A::B::C



[Watch Video Solution](#)

12. An ideal gas is allowed to expand in vacuum in rigid insulator container. Choose the correct alternative (s).

- A. Work done by the gas is zero

- B. Pressure of the gas is inversely proportional to volume of the gas
- C. Change in internal energy of the gas is zero
- D. Temperature of the gas remains constant during expansion

Answer: A::B::C::D



Watch Video Solution

13. One mole of an ideal monoatomic gas is taken from A to C along the path ABC . The temperature of the gas at A is

T_0 . For the process ABC :

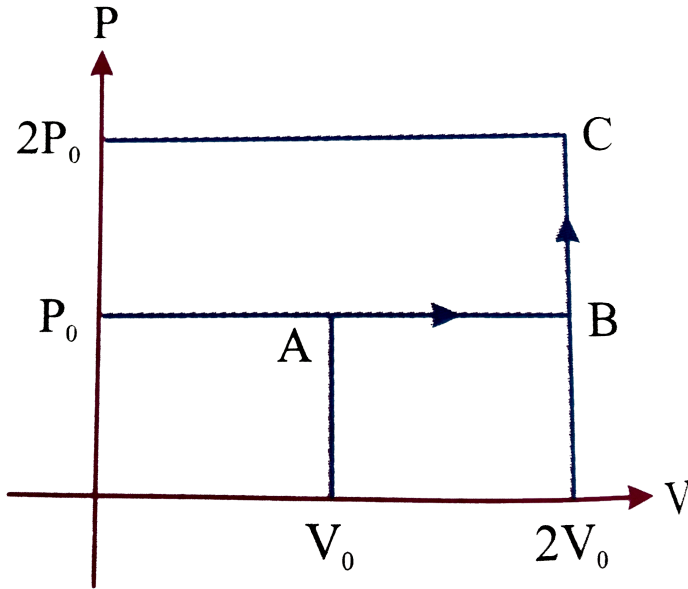

A. work done by the gas is RT_0

B. change in internal energy of the gas is $\frac{11}{2}RT_0$

C. heat absorbed by the gas is $\frac{11}{2}RT_0$

D. heat absorbed by the gas is $\frac{13}{2}RT_0$

Answer: A:C



Watch Video Solution

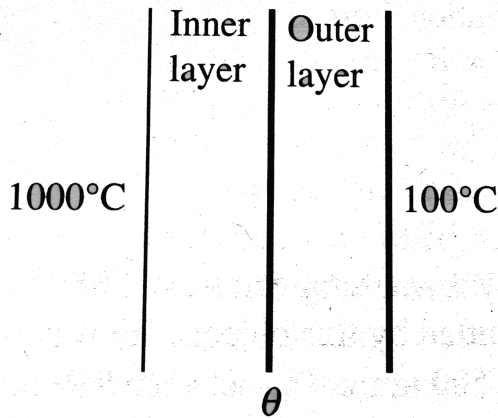

14.

The temperature drop through a two layer furnace wall is 900°C . Each layer is of equal area of cross section. Which of the following actions will result in lowering the temperature θ of the interface?

- A. By increasing the thermal conductivity of outer layer
- B. By increasing thermal conductivity of inner layer
- C. By increasing thickness of outer layer
- D. By increasing thickness of inner layer

Answer: A::D

 Watch Video Solution

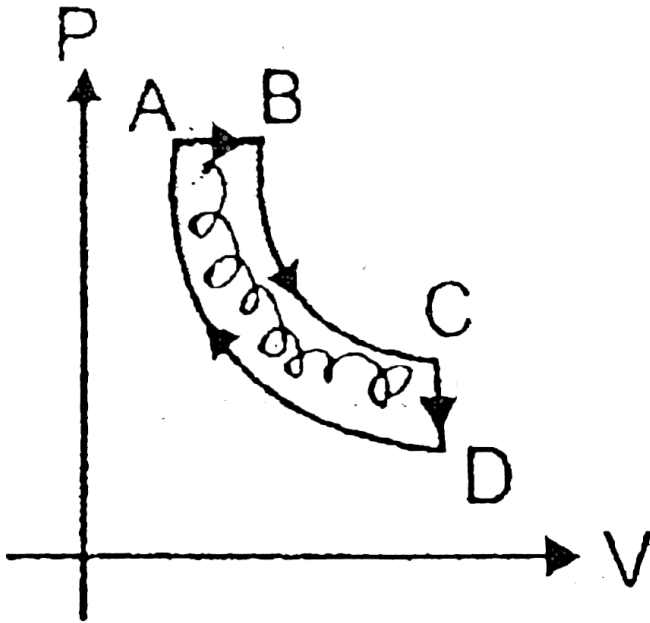

15.

n moles of a monoatomic gas undergoes a cyclic process ABCDA as shown. Process AB is isobaric, process BC is adiabatic process CD is isochoric and process DA is isothermal

the maximum temperature and minimum temperature in cycle are $4T_0$ and T_0 respectively. Then:

A. $T_B > T_C > T_D$

B. heat is released by the gas in the process CD

C. heat is supplied to the gas in the process AB

D. total heat supplied to the gas is $2nRT_0 \ln(2)$

Answer: A::B::C



[Watch Video Solution](#)

16. At ordinary temperatures, the molecules of an ideal gas have only translational and rotational kinetic energies. At high temperatures, they may also have vibrational energy. As a

result of this, at higher temperatures, molar specific heat capacity at constant volume, C_V is

- A. $C_V = \frac{3}{2}R$ for a monotomic gas
- B. $C_V > \frac{3}{2}R$ for a monoatomic gas
- C. $C_V < \frac{5}{2}R$ for diatomic gas
- D. $C_V > \frac{5}{2}R$ for a diatomic gas

Answer: A:D



[Watch Video Solution](#)

17. 1 kg of ice at $0^\circ C$ is mixed with 1.5 kg of water at $45^\circ C$

[latent heat of fusion = 80 cal//gl. Then

A. the temperature of the mixture is $0^\circ C$

B. mixture contains $156.25g$ of ice

C. mixture contains $843.75g$ of ice

D. the temperature of the mixture is $15^{\circ}C$

Answer: A::B



Watch Video Solution

18. A vessel contains 1 mole of O_2 gas (molar mass 32) at a temperature T . The pressure of the gas is p . An identical vessel containing one mole of the gas (molar mass 4) at a temperature $2T$ has a pressure of

A. (a) pressure in the container Y is $\frac{p}{8}$

B. (b) kinetic energy of O_2 molecule = kinetic energy of He molecule

C. (c) pressure in the container Y is $2p_6$

D.

Answer: C::D



[Watch Video Solution](#)

19. In a thermodynamic process helium gas obeys the law $TP^{-2/5} = \text{constant}$, if temperature of 2 moles of the gas is raised from T to $3T$, then

A. heat given to the gas is $9RT$

B. heat given to the gas is zero

C. increase in internal energy is $6RT$

D. work done by the gas is $-6RT$

Answer: B::C::D

 Watch Video Solution

20. The density (ρ) of an ideal gas varies with temperature T as shown in figure. Then

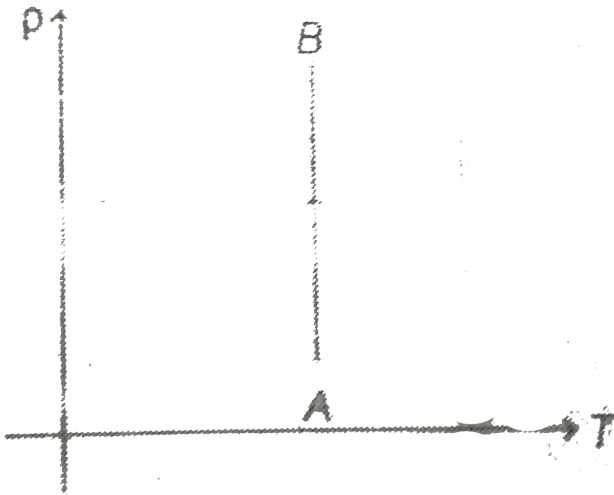

- A. the product of P and V at A is equal to the product of P and V at B
- B. pressure at B is greater than the pressure at A
- C. work done by the gas during process AB is negative
- D. the change in internal energy from the A to B is zero

Answer: A::B::C::D



Watch Video Solution

21. A gas is found to obey the law $P^2V = \text{constant}$. The initial temperature and volume are T_0 and V_0 . If the gas expands to a volume $3V_0$, then

A. final temperature becomes $\sqrt{3}T_0$

B. internal energy of the gas increases

C. final temperature becomes $\frac{T_0}{\sqrt{3}}$

D. internal energy of the gas decreases

Answer: A::B



Watch Video Solution

22. n moles of an ideal gas undergo a process in which the temperature changes with volume as $T = kv^2$. The work done by the gas as the temperature changes from T_0 to $4T_0$ is

A. work done by the gas is $3nRT_0$

B. heat supplied to the gas is $6nRT_0$

C. work done by the gas is $\frac{3}{2}nRT_0$

D. heat supplied to the gas is $\frac{3}{2}nRT_0$

Answer: B::C



Watch Video Solution

23. One mole of an ideal monatomic gas (initial temperature T_0) is made to go through the cycle abca as shown in the figure. If U denotes the internal energy, then choose the

correct alternatives

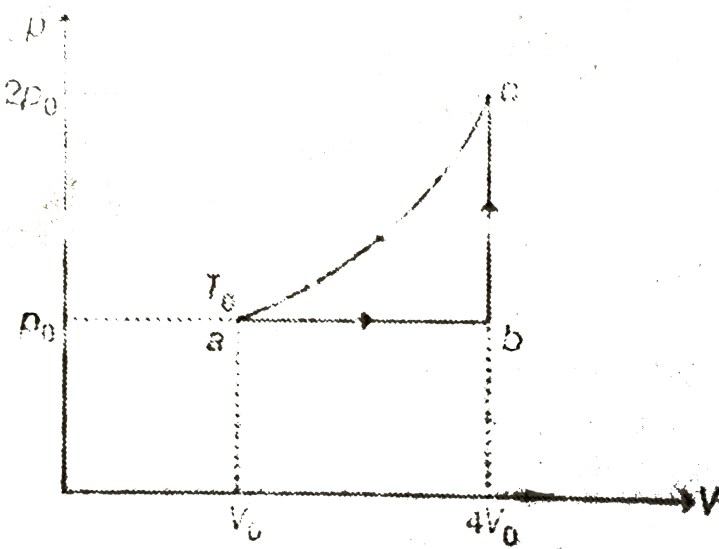

A. $U_c - U_a = 10.5RT_0$

B. $U_b - U_a = 4.5RT_0$

C. $U_c > U_b > U_a$

D. $U_c - U_b = 6RT_0$

Answer: A::B::C::D

 Watch Video Solution

24. Two identical vessels contain helium and hydrogen gases at same temperature, then

A. (a) average kinetic energy per mole of hydrogen = average kinetic energy per mole of helium

B. (b) average translational kinetic energy per mole of hydrogen = average translational kinetic energy per mole of helium

C. (c) average kinetic energy per mole of hydrogen = $\frac{3}{5}$ average kinetic energy per mole of helium

D. (d) average kinetic energy per mole of hydrogen = $\frac{5}{3}$ average kinetic energy per mole of helium

Answer: B::D



Watch Video Solution

25. For an ideal gas :

- A. A) the change in internal energy in a constant pressure process from temperature T_1 and T_2 is equal to $nC_V(T_2 - T_1)$, where C_V is the number of moles of the gas
- B. B) the change in internal energy of the gas and the work done by the gas are equal in magnitude in an adiabatic process
- C. C) the internal energy does not change in an isothermal process
- D. D) no heat is added or removed in an adiabatic process

Answer: A::B::C::D



Watch Video Solution

26. An ideal gas is taken from the state A (pressure p , volume V) to the state B (pressure $\frac{p}{2}$, volume $2V$) along a straight line path in the p - V diagram. Select the correct statement(s) from the following.

- A. The work done by the gas in the process A to B exceeds the work that would be done by it if the system were taken from A to B along an isotherm
- B. In the T - V diagram, the path AB becomes a part of a parabola

C. In the p - T diagram, the AB becomes a part of a hyperbola

D. In going from A to B, the temperature T of the gas decreases

Answer: A::B::D



Watch Video Solution

27. From the following statements concerning ideal gas at any given temperature T , select the correct one (s)

A. A) The coefficient of volume expansion at constant pressure is the same for all ideal gases

- B. B) The average translational kinetic energy per molecule of oxygen gas is $3 kT$, k being Boltzmann constant
- C. C) The mean-free path of molecules increases with decrease in the pressure
- D. D) In a gaseous mixture, the average translational kinetic energy of the molecules of each component is different

Answer: A::C



Watch Video Solution

28. Which of the following quantities is the same for all ideal gases at the same temperature?

- A. the kinetic energy of equal moles of gas

B. the kinetic energy of equal mass of gas

C. the number of molecules of equal moles of gas

D. the number of molecules of equal of gas

Answer: C



[Watch Video Solution](#)

29. During an experiment, an ideal gas is found to obey a condition $\frac{p^2}{\rho} = \text{constant}$. (ρ = density of the gas). The gas is initially at temperature (T), pressure (p) and density ρ . The gas expands such that density changes to $\rho/2$.

A. The pressure of the gas changes to $\sqrt{2}p$

B. The temperature of the gas changes to $\sqrt{2}T$

C. The graph of the above process on the p-T diagram is parabola

D. The graph of the above process on the p-T diagram is hyperbola

Answer: B::D

 [Watch Video Solution](#)

30. An ideal gas can be expanded from an initial state to a certain volume through two different processes $PV^2 =$ constant and (ii) $P = KV^2$ where K is a positive constant.

Then

A. Final temperature in (i) will be greater than in (ii)

B. Final temperature in (ii) will be greater than in (i)

C. Total heat given to the gas in (i) case is greater than in

(ii)

D. Total heat given to the gas in (ii) case is greater than in

(i)

Answer: B::D



Watch Video Solution

31. In a cyclic process, a gas is taken from state A and B via path -I as shown in the indicator diagram and taken back to

state A from state B via path-II. In the complete cycle

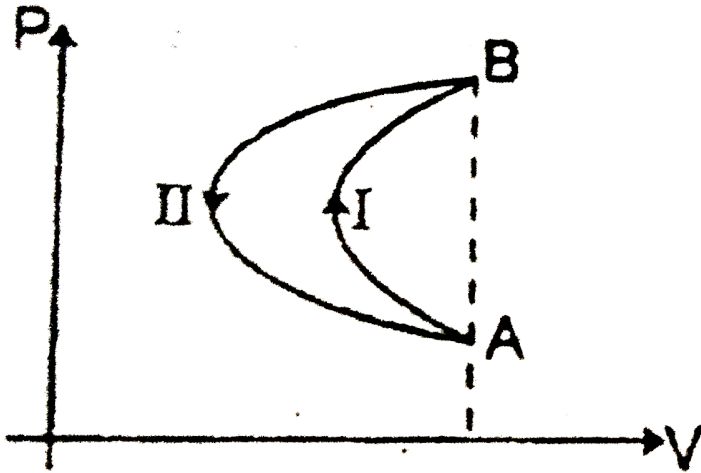

- A. A) work is done on the gas
- B. B) heat is given to the gas
- C. C) work is done by the gas
- D. D) heat is taken from the gas

Answer: B::C

 Watch Video Solution

32. During the melting of a slab of ice at 273K at atmospheric pressure,

- A. positive work is done by the ice water system on the atmosphere
- B. positive work is done on the ice water system by the atmosphere
- C. the internal energy of the ice water system increases
- D. the internal energy of the ice water system decreases

Answer: B::C



Watch Video Solution

33. Two large holes are cut in a metal sheet. If this is heated, distances AB and BC , (as shown)

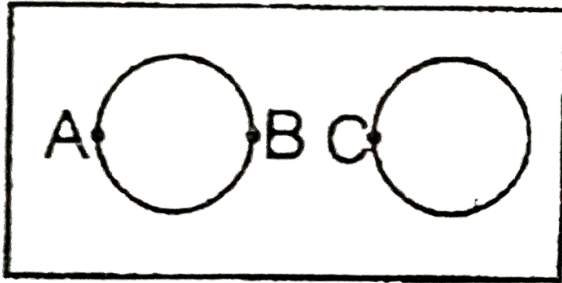

- A. A) AB increases
- B. B) BC increases
- C. C) BC decreases
- D. D) BC remains same

Answer: A::B



Watch Video Solution

34. Two identical beakers with negligible thermal expansion are filled with water to the same level at $4^{\circ}C$. If one says A is heated while the other says B is cooled, then:

- A. water level in A must rise
- B. water level in B must rise
- C. water level in A must fall
- D. water level in B must fall

Answer: A::B



Watch Video Solution

35. A process is shown in the diagram. Which of the following curves may represent the same process ? BC is rectangular hyperbola.

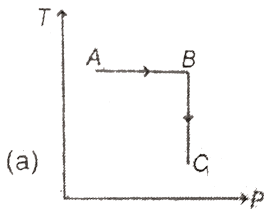
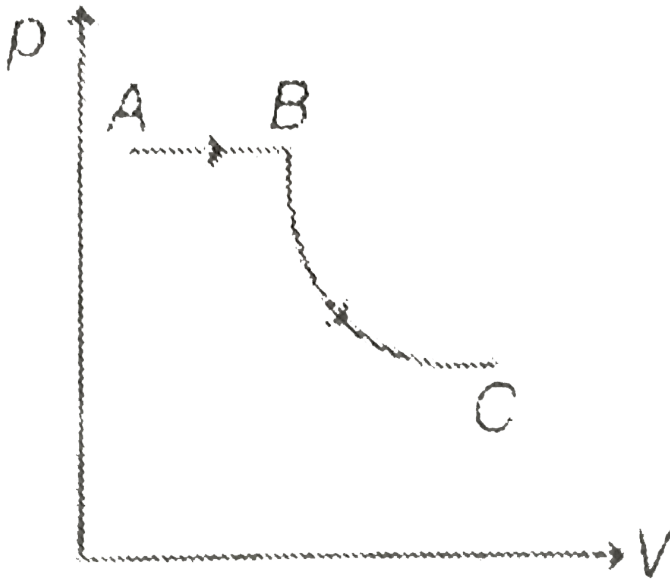

A.

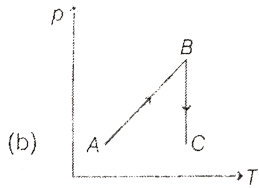

B.

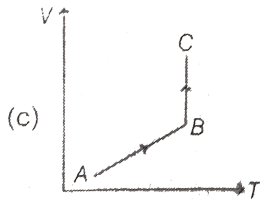

C.

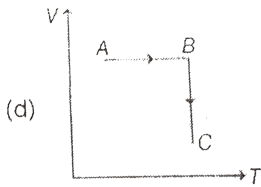

D.

Answer: C

 **Watch Video Solution**

36. A student records ΔQ , ΔU and ΔW for a thermodynamic cycle $A \rightarrow B \rightarrow C \rightarrow A$. Certain entries are missing. Find

correct entry in following options.

	AB	BC	CA
DW	40J		30J
DU		50J	
DQ	150J	10J	

A. $W_{BC} = -70J$

B. $\Delta Q_{CA} = 130J$

C. $\Delta U_{AB} = 190J$

D. $\Delta U_{CA} = -160J$

Answer: D



Watch Video Solution

37. Two rods of different materials are placed between massive walls as shown in figure. The cross section of the rods is A , their moduli of elasticity are E_1 and E_2 respectively. If rods are heated by t degrees, then (coefficients of linear expansion of material of rods are α_1 and α_2 respectively)

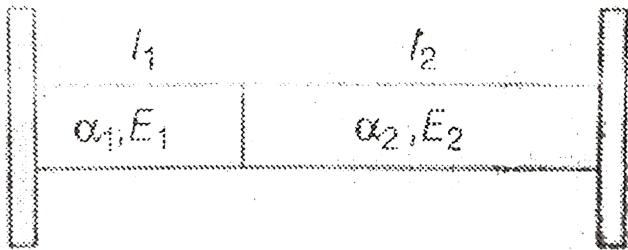

- A. A) the strain produced in both rods is equal
- B. B) the stress produced in both the rods is equal
- C. C) the force exerted by one rod on the other is

$$\frac{\alpha_1 l_1 + \alpha_2 l_2}{\frac{l_1}{E_1} + \frac{l_2}{E_2}} At$$

D.D) the force exerted by one rod on the other is

$$\frac{(E_1 - E_2)^2 A}{E_1 + E_2}$$

Answer: B::C



Watch Video Solution

38. Two metal rods X and Y having equal cross-sectional areas are joined in series. One end of which is heated. After some time, the temperature gradient along each rod is found to be uniform, but greater in X than that in Y. Which of the following can be inferred

- A. both the rods may be of different lengths
- B. The heat current is the same in both the rods
- C. Both the rods are of equal lengths

D. X is better conductor of heat than Y

Answer: A::B



Watch Video Solution

39. The graph below shows V-p curve for three processes.

Choose the correct statement(s) :



- A. Work done is maximum in process 1
- B. Temperature must increase in process 2 and 3
- C. Heat must be supplied in process 1
- D. If final volume of gas in process 1,2 and 3 are same. Then temperature must be same.

Answer: A::C



Watch Video Solution

40. One mole of an ideal gas undergoes a process such that

$P \propto \frac{1}{T}$. The molar heat capacity of this process is $4R$.

A. The work done by the gas is $2R\Delta T$

B. Degree of freedom of the gas is 4

C. Degree of freedom of the gas is 3

D. γ or $\left(\frac{C_p}{C_V}\right)$ for the gas is 1.5

Answer: A::B::D



Watch Video Solution

41. One mole of an ideal monoatomic gas is taken through a cyclic process as shown. Choose the correct option(s).

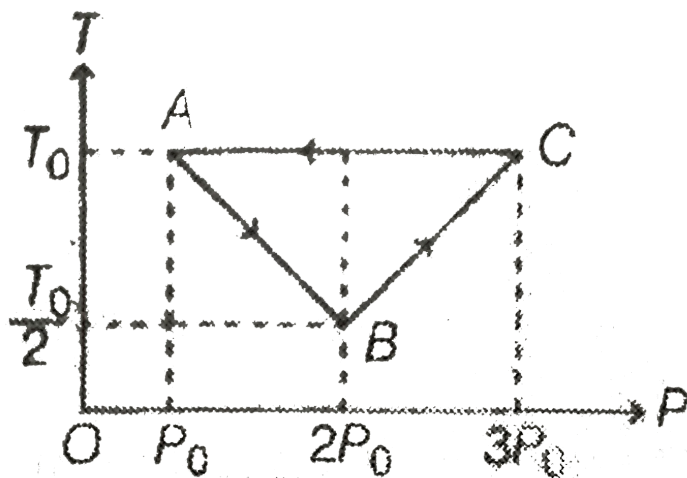

- A. Work done in process CA is $RT_0 \ln 3$.
- B. Heat given to the gas in process CA is $RT_0 \ln 3$
- C. The magnitude of change in internal energy in process AB and BC must be same
- D. The change in internal energy in process AB is negative.

Answer: A::B::C::D

42. Figure (Five straight line numbered 1, 2, 3, 4 and 5) shows graph of change in temperature ΔT versus heat supplied ΔQ for different process performed on a gas of one mole.

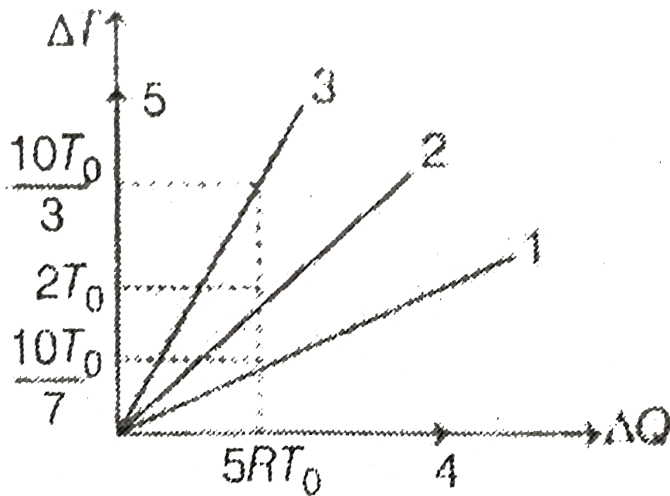

A. lines 4 and 5 (coinciding with ΔQ and ΔT axis respectively) represent isothermal and adiabatic processes respectively

B. line 2 represents isochoric process for diatomic gas

C. lines 1 and 3 represent isochoric process for a diatomic gas and isochoric process for a monoatomic gas respectively

D. line 2 represents isobaric process for a monoatomic gas.

Answer: A::B::C::D



Watch Video Solution

43. Two identical objects A and B (emissivity e_A and e_B , $e_A \neq e_B$) are placed in an enclosure, Temperature of body A, B and enclosure are same and constant.

- A. A) Heat emitted by body A is not equal to heat emitted by body B
- B. B) Heat absorbed by body A is not equal to heat absorbed by body B
- C. C) If $e_A > e_B$, body A absorbs more heat than body B
- D. D) If $e_A < e_B$, body A emits less heat than body B

Answer: A::B::C::D



Watch Video Solution

44. n mole of an ideal gas undergo an isothermal process at temperature T . Further, P-V graph of the process is as shown in the figure. Tangent at point A, cuts the V-axis at point D. AO is the line joining the point A to the origin O of P-V diagram.

Choose from following the correct option(s).

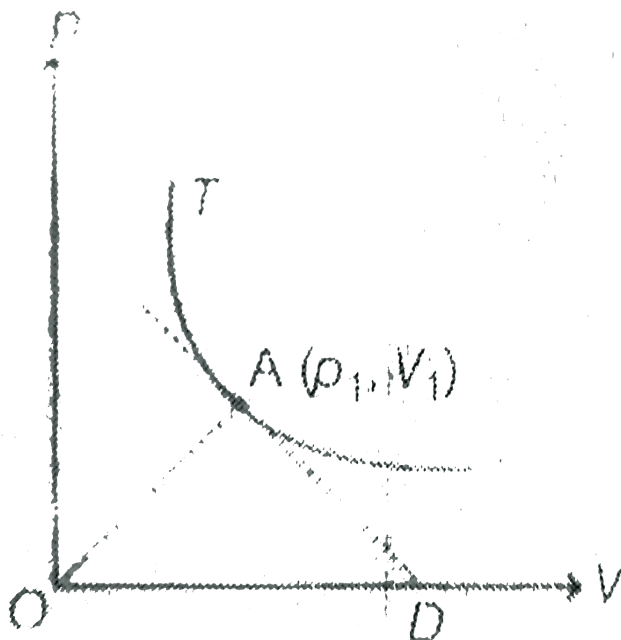

A. A) coordinates of point D is $\left(\frac{3V_1}{2}, 0\right)$

B. B) coordinates of point D is $(2V_1, 0)$

C. C) area of the triangle AOD is nRT

D. D) area of the triangle AOD is $\frac{3}{4} nRT$

Answer: B::C



Watch Video Solution

C. Comprehension Type Questions

1. Five rods of same material and same cross-section are joined as shown. Lengths of rods ab , ad and bc are l , $2l$ and $3l$ respectively. Ends a and c are maintained at temperatures $200^\circ C$ and $0^\circ C$ respectively.

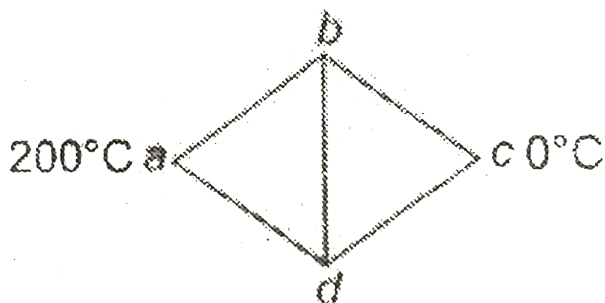

For what length x of rod dc there will be no heat flow through rod bd ?

A. $4l$

B. $2l$

C. $6l$

D. $9l$

Answer: C



[Watch Video Solution](#)

2. Five rods of same material and same cross-section are joined as shown. Lengths of rods ab , ad and bc are l , $2l$ and $3l$ respectively. Ends a and c are maintained at temperatures $200^\circ C$ and $0^\circ C$ respectively.

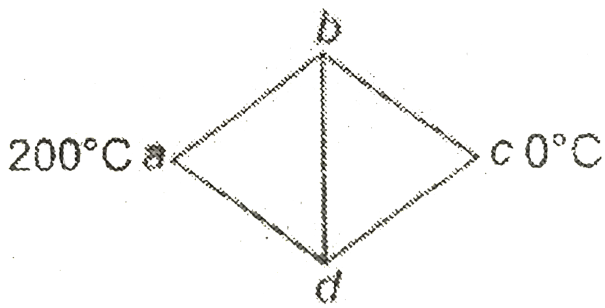

For what length x of rod dc there will be no heat flow through rod bd ?

- A. $120^\circ C$
- B. $160^\circ C$
- C. $90^\circ C$
- D. $150^\circ C$

Answer: D



[Watch Video Solution](#)

3. graph of an ideal gas is as shown in figure.

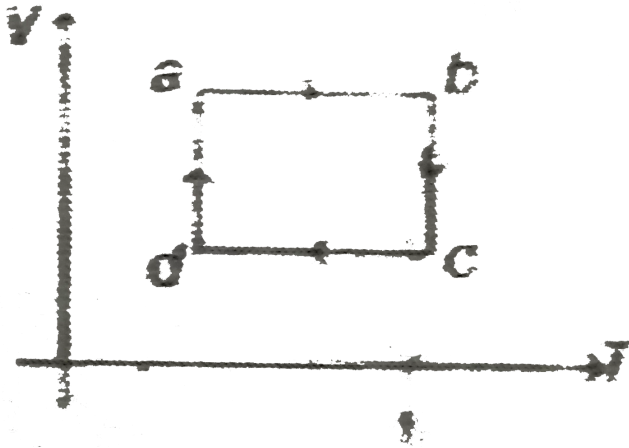

Work done by the gas in complete cyclic process about is

- A. zero
- B. positive
- C. negative
- D. Data is insufficient

Answer: C



Watch Video Solution

4. graph of an ideal gas is as shown in figure.

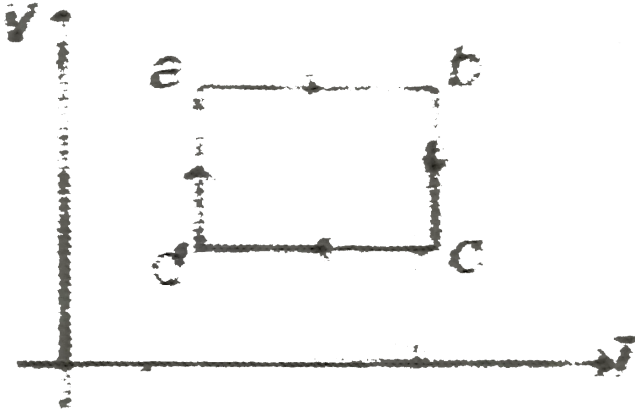

Heat is supplied to the gas in process (s).

- A. da, ab and bc
- B. da and ab
- C. da only
- D. ab and bc

Answer: B



Watch Video Solution

5. Two moles of a monoatomic gas are taken from a to c, via three paths abc, ac and adc.

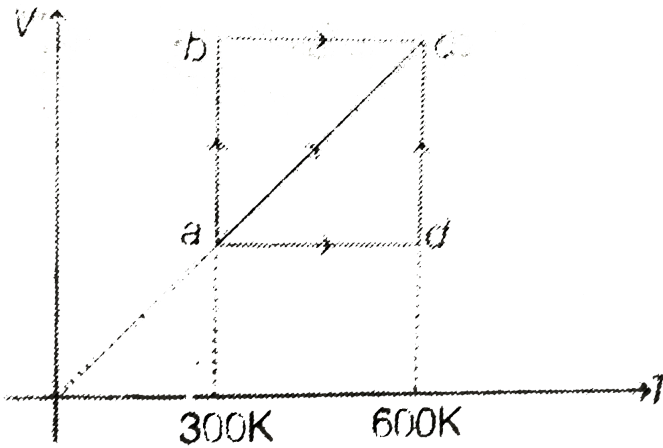

Work done by the gas in process ac is

- A. 1000 R
- B. 900 R
- C. 600 R
- D. 1500 R

Answer: C



Watch Video Solution

6. Two moles of a monoatomic gas are taken from a to c, via three paths abc, ac and adc.

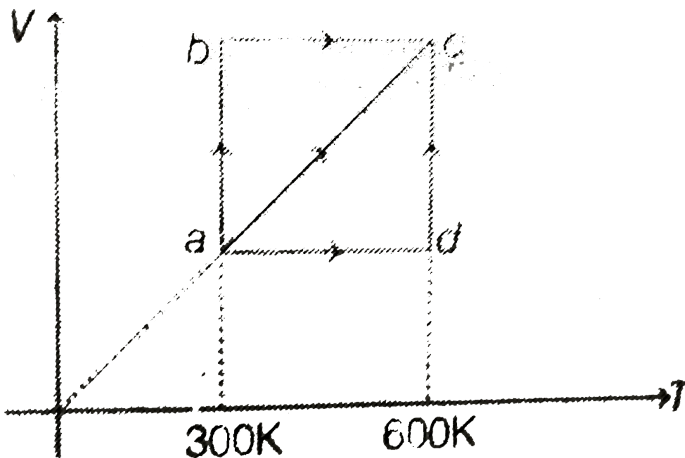

If work done by the gas in abc is W_1 , in ac, work done is W_2 and in adc, work done is W_3 , then

A. $W_2 > W_3 > W_1$

B. $W_1 > W_2 > W_3$

C. $W_2 > W_1 > W_3$

D. $W_3 > W_2 > W_1$

Answer: D



Watch Video Solution

7. The internal energy of a gas is given by $U = 3 pV$. It expands from V_0 to $2V_0$ against a constant pressure p_0 .

The heat absorbed by the gas in the process is

A. $p_0 V_0$

B. $2p_0 V_0$

C. $3p_0 V_0$

D. $4p_0V_0$

Answer: D



Watch Video Solution

8. The internal energy of a gas is given by $U = 3 pV$. It expands from V_0 to $2V_0$ against a constant pressure p_0 .

What is the value of $\gamma (= C_P / C_V)$ for the given gas?

A. 1.33

B. 1.4

C. 1.67

D. None of these

Answer: A



Watch Video Solution

9. A certain amount of ice is supplied heat at a constant rate for 7 min. For the first one minute the temperature rises uniformly with time. Then it remains constant for the next 4 min and again the temperature rises at uniform rate for the last 2 min. Given $S_{\text{ice}} = 0.5 \text{ cal/g}^\circ \text{C}$, $L_f = 80 \text{ cal/g}$.

The initial temperature of ice is

- A. -10°C
- B. -20°C
- C. -30°C
- D. -40°C

Answer: D



Watch Video Solution

10. A certain amount of ice is supplied heat at a constant rate for 7 min. For the first one minute the temperature rises uniformly with time. Then it remains constant for the next 4 min and again the temperature rises at uniform rate for the last 2 min. Given $S_{\text{ice}} = 0.5 \text{ cal} / \text{g}^\circ \text{C}$, $L_f = 80 \text{ cal} / \text{g}$.

Final temperature at the end of 7 min is

- A. 10°C
- B. 20°C
- C. 30°C
- D. 40°C

Answer: D

11. An ideal diatomic gas with $C_V = \frac{5R}{2}$ occupies a volume V_1 at a pressure P_1 . The gas undergoes a process in which the pressure is proportional to the volume. At the end of the process the rms speed of the gas molecules has doubled from its initial value.

The molar heat capacity of the gas in the given process is

A. $3R$

B. $3.5R$

C. $4R$

D. $2.5R$

Answer: A



Watch Video Solution

12. An ideal diatomic gas with $C_V = \frac{5R}{2}$ occupies a volume V_1 at a pressure P_1 . The gas undergoes a process in which the pressure is proportional to the volume. At the end of the process the rms speed of the gas molecules has doubled from its initial value.

The molar heat capacity of the gas in the given process is

- A. (a) $7p_1 V_1$
- B. (b) $8p_1 V_1$
- C. (c) $9p_1 V_1$
- D. (d) $10p_1 V_1$

Answer: C



[Watch Video Solution](#)

13. When a system is taken from state 'a' to state 'b' along the path 'acd', it is found that a quantity of heat $Q = 200J$ is absorbed by the system and a work $W = 80J$ is done by it. Along the path 'adb', $Q = 144J$. The work done along the path 'adb' is

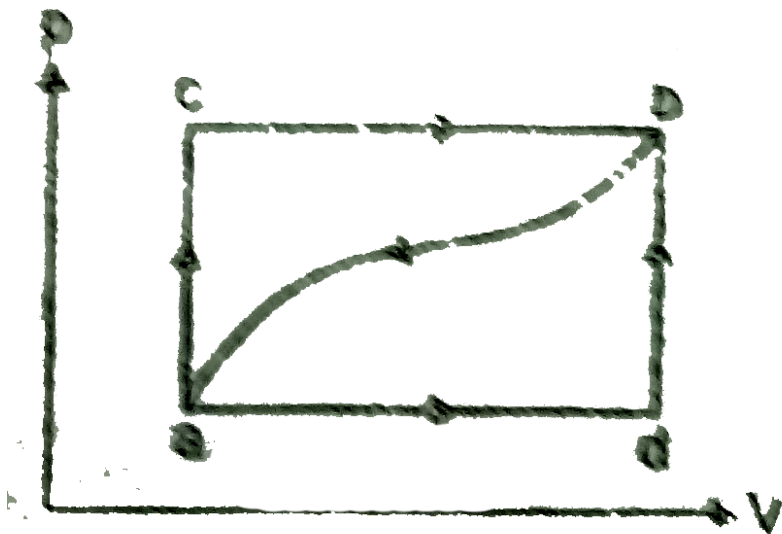

A. 6 J

B. 12 J

C. 18 J

D. 24 J

Answer: D



Watch Video Solution

14. When a system is taken from state 'a' to state 'b' along the path 'acb', it is found that a quantity of heat $Q = 200 \text{ J}$ is absorbed by the system and a work $W = 80 \text{ J}$ is done by it. Along the path 'adb', $Q = 144 \text{ J}$

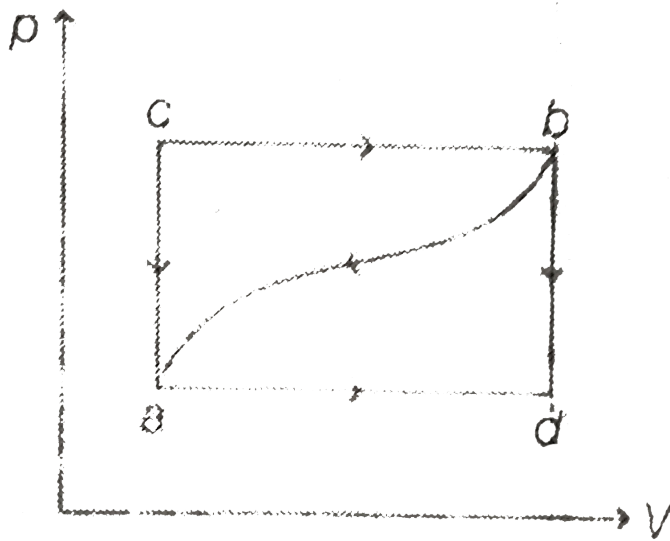

In the above question, if the work done on the system along the curved path 'ba' is 52J, heat absorbed is

- A. $-140J$
- B. $-172J$
- C. 140 J
- D. 172 J

Answer: B



15. When a system is taken from state 'a' to state 'b' along the path 'acb', it is found that a quantity of heat $Q = 200 \text{ J}$ is absorbed by the system and a work $W = 80 \text{ J}$ is done by it. Along the path 'adb', $Q = 144 \text{ J}$

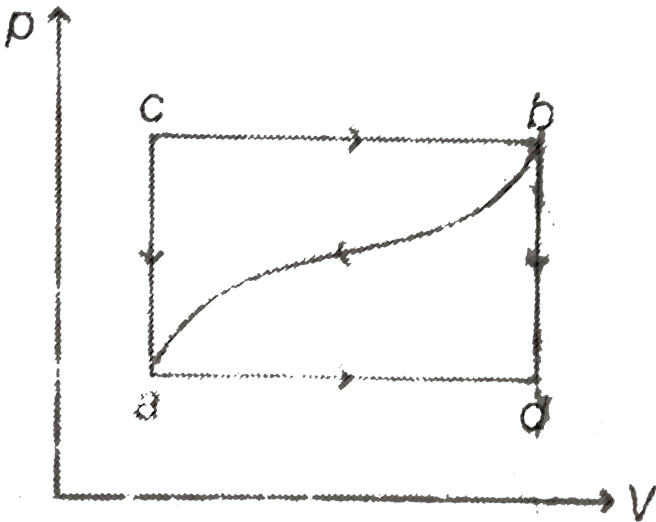

In above question, if $U_a = 40 \text{ J}$, value of U_b will be

A. -50 J

B. 100 J

C. $-120J$

D. $160J$

Answer: D



Watch Video Solution

16. When a system is taken from state 'a' to state 'b' along the path 'acb', it is found that a quantity of heat $Q = 200 \text{ J}$ is absorbed by the system and a work $W = 80 \text{ J}$ is done by it. Along the path 'adb', $Q = 144 \text{ J}$

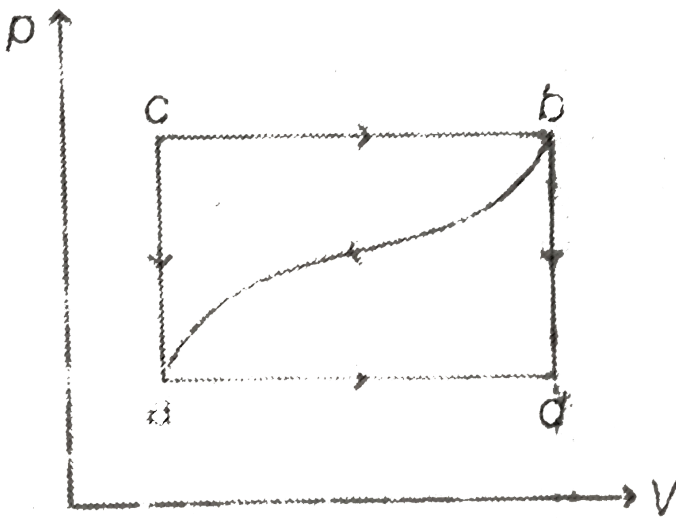

In the above question, if $U_d = 88J$, heat absorbed for the path 'db' is

- A. $-72J$
- B. $72J$
- C. $144J$
- D. $-144J$

Answer: B



17. Two rods A and B of same cross-sectional area A and length l are connected in series between a source ($T_1 = 100^\circ C$) and a sink ($T_2 = 0^\circ C$) as shown in figure. The rod is laterally insulated.

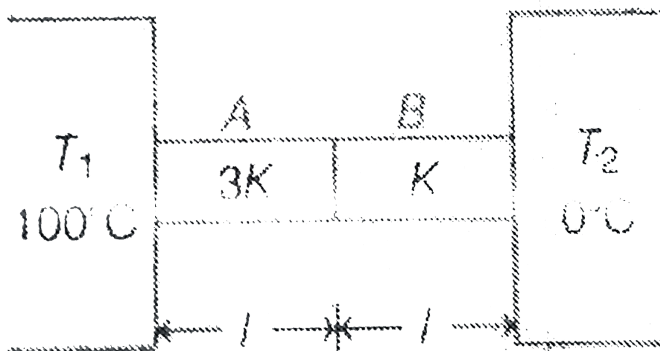

The ratio of the thermal resistance of the rods is

A. $\frac{R_A}{R_B} = \frac{1}{3}$

B. $\frac{R_A}{R_B} = 3$

C. $\frac{R_A}{R_B} = \frac{3}{4}$

$$D. \frac{R_A}{R_B} = \frac{4}{3}$$

Answer: A

 Watch Video Solution

18. Two rods A and B of same cross-sectional area A and length l are connected in series between a source ($T_1 = 100^\circ C$) and a sink ($T_2 = 0^\circ C$) as shown in figure. The rod is laterally insulated.

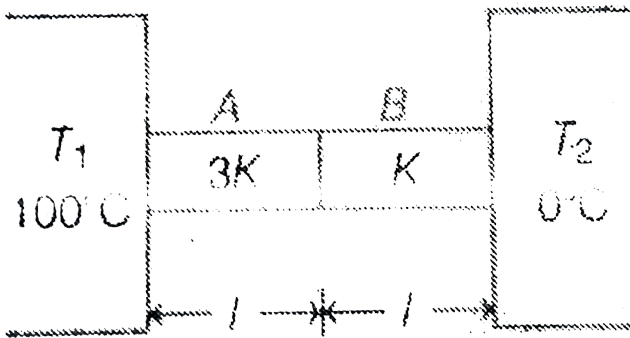

If T_A and T_B are the temperature drops across the rod A and B, then

A. $\frac{T_A}{T_B} = \frac{3}{1}$

B. $\frac{T_A}{T_B} = \frac{1}{3}$

C. $\frac{T_A}{T_B} = \frac{3}{4}$

D. $\frac{T_A}{T_B} = \frac{4}{3}$

Answer: B



[Watch Video Solution](#)

19. Two rods A and B of same cross-sectional area A and length l are connected in series between a source ($T_1 = 100^\circ C$) and a sink ($T_2 = 0^\circ C$) as shown in figure. The rod is laterally insulated.

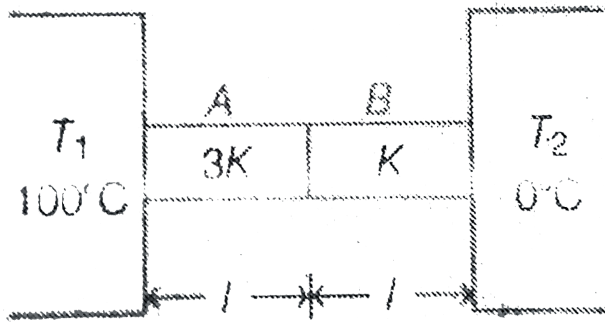

If G_A and G_B are the temperature gradients across the rod A and B, then

A. $\frac{G_A}{G_B} = \frac{3}{4}$

B. $\frac{G_A}{G_B} = \frac{1}{3}$

C. $\frac{G_A}{G_B} = \frac{3}{4}$

D. $\frac{G_A}{G_B} = \frac{4}{3}$

Answer: B

[Watch Video Solution](#)

20. A sample of ideal gas is taken through the cyclic process shown in the figure. The temperature of the gas in state A is $T_A = 200$ K. In states B and C the temperature of the gas is the same.

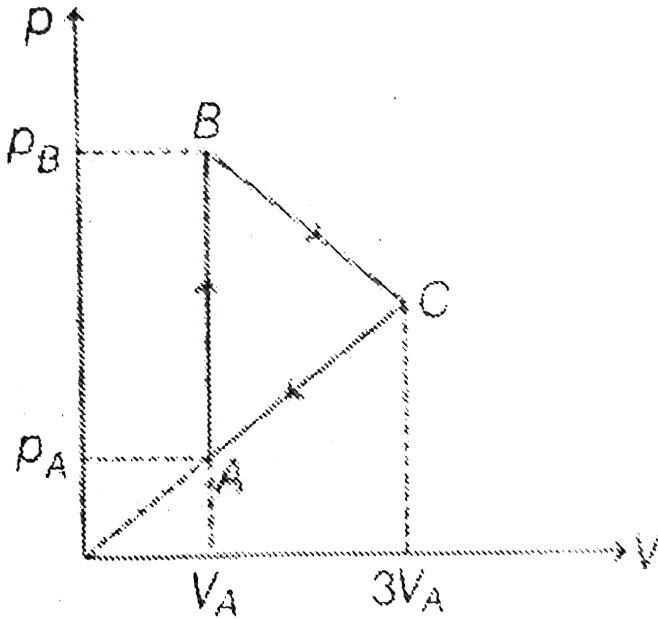

Net work done by the gas in the process is

A. $2p_A V_A$

B. $4p_A V_A$

C. $6p_A V_A$

D. $8p_A V_A$

Answer: D



Watch Video Solution

21. A sample of ideal gas is taken through the cyclic process shown in the figure. The temperature of the gas in state A is $T_A = 200$ K. In states B and C the temperature of the gas is the same.

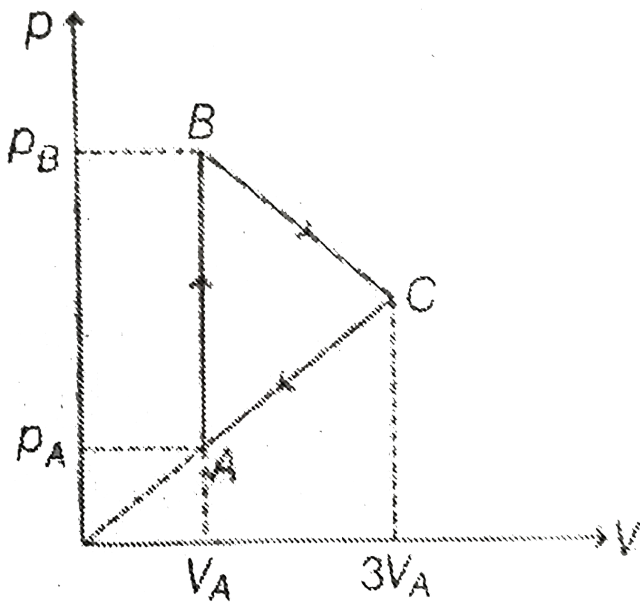

Which of the following graphs best represent the cyclic process in T-V diagram

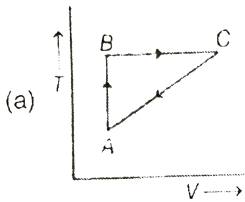

A.

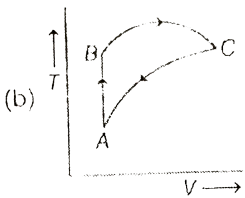

B.

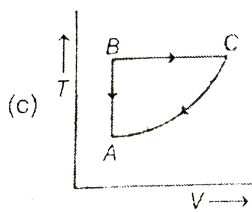

C.

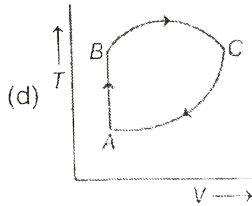

D.

Answer: D

 [Watch Video Solution](#)

22. A sample of ideal gas is taken through the cyclic process shown in the figure. The temperature of the gas in state A is $T_A = 200$ K. In states B and C the temperature of the gas is the same.

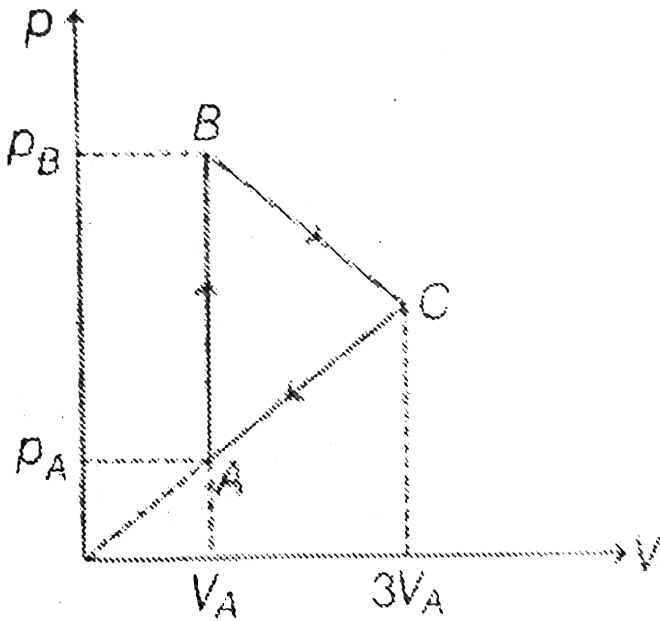

Net work done by the gas in the process is

- A. 600 K
- B. 1200 K
- C. 2400 K
- D. None of these

Answer: C



Watch Video Solution

23. One mole of an ideal monoatomic gas is taken through cyclic process ABC as shown in the graph with pressure and temperature as coordinate axes. Process AB is defined as $PT = \text{constant}$. Take universal gas constant to be R . Then:

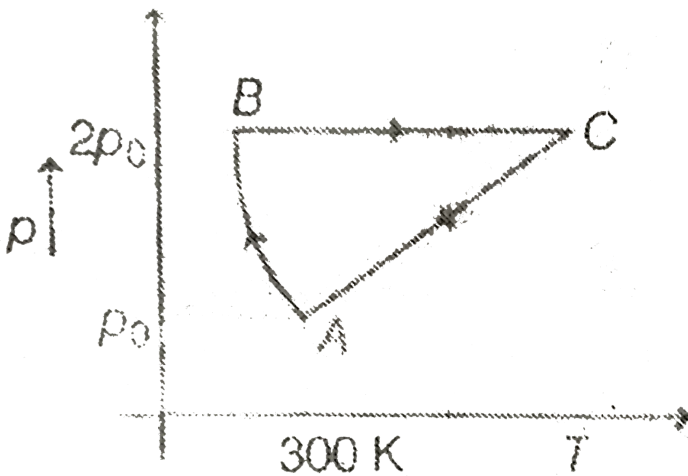

work done on gas in the process AB is

A. $675 R$

B. $975 R$

C. 300 R

D. 600 R

Answer: C



Watch Video Solution

24. One mole of an ideal monoatomic gas is taken through cyclic process ABC as shown in the graph with pressure and temperature as coordinate axes. Process AB is defined as $PT = \text{constant}$. Take universal gas constant to be R. Then:

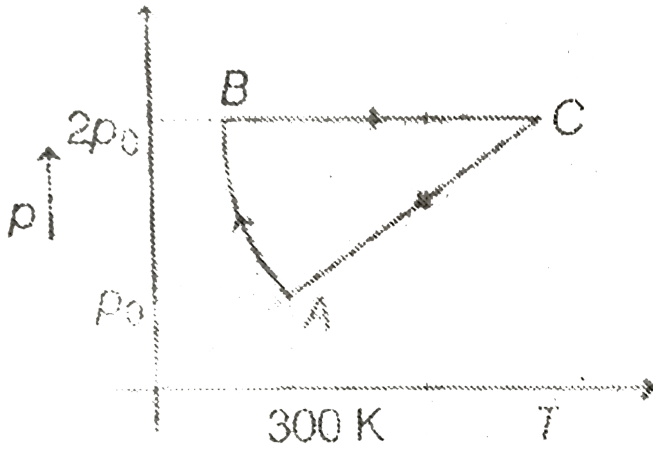

Change in internal energy of gas in the process CA is

- A. $-350R$
- B. $-450R$
- C. $-550R$
- D. $-600R$

Answer: B

 [Watch Video Solution](#)

25. One mole of an ideal monatomic gas undergoes a linear process from A to B in which its pressure p and its volume V change as shown in figure.

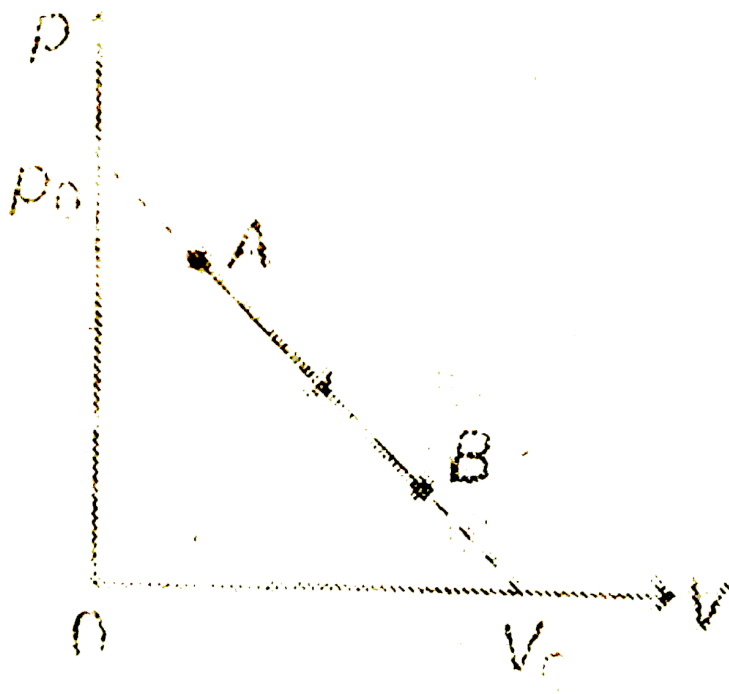

The maximum temperature of the gas during this process is

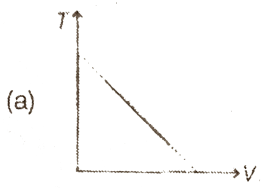

A.

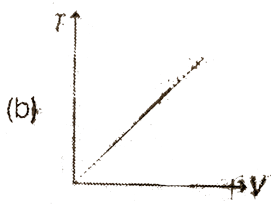

Watch Video Solution

26. One mole of an ideal monatomic gas undergoes a linear process from A to B in which its pressure p and its volume V change as shown in figure.

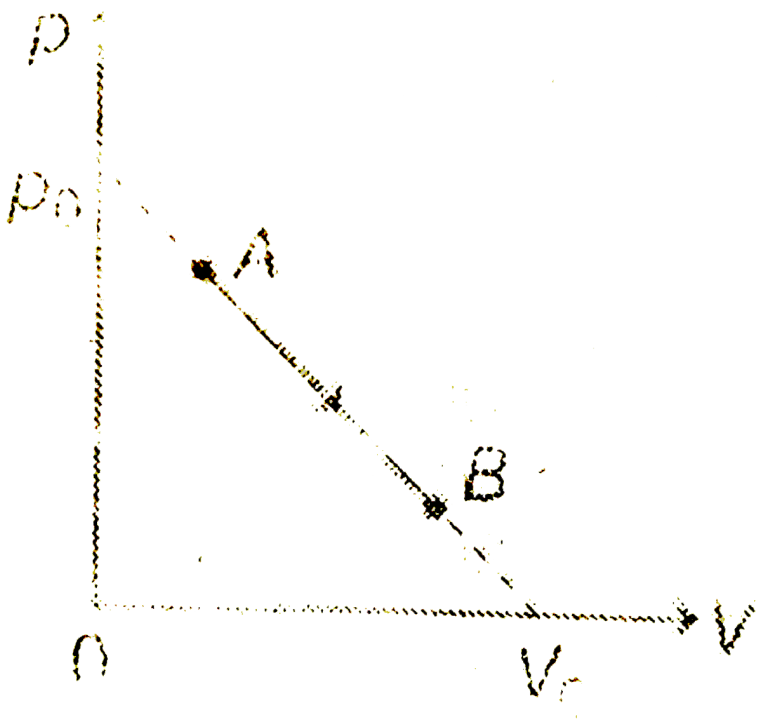

The maximum temperature of the gas during this process is

- A. $\frac{p_0 V_0}{2R}$
- B. $\frac{p_0 V_0}{4R}$
- C. $\frac{3p_0 V_0}{4R}$
- D. $\frac{3p_0 V_0}{2R}$

Answer: B

27. A sample of mono-atomic ideal gas is taken through a cyclic process ABCDA. A graph is plotted in which heat exchanged by the gas upto an instant is shown on x-axis and work done by the gas upto that instant is shown on y-axis.

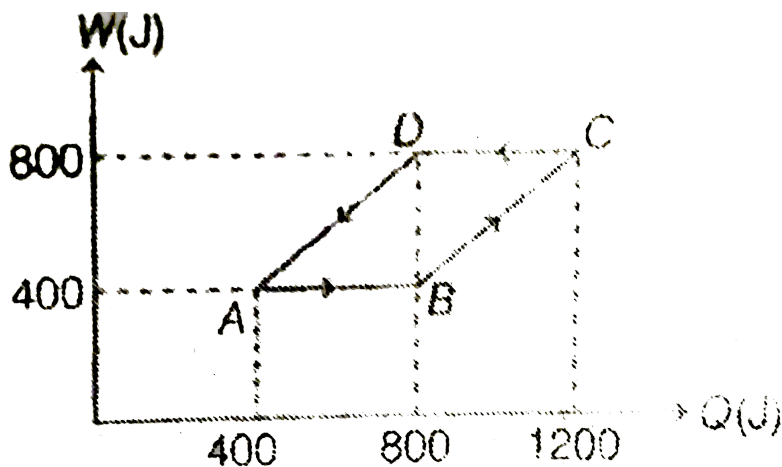

The given cyclic process can be represented on a pressure-volume graph as:

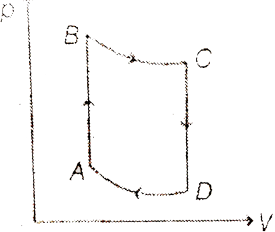

A.

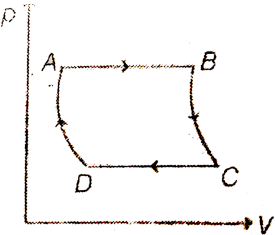

B.

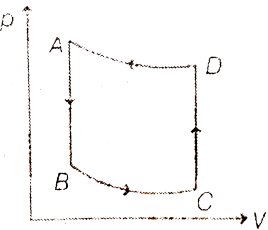

C.

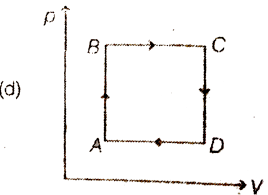

D.

(d)

Answer: A



Watch Video Solution

28. A sample of mono-atomic ideal gas is taken through a cyclic process ABCDA. A graph is plotted in which heat exchanged by the gas upto an instant is shown on x-axis and work done by the gas upto that instant is shown on y-axis.

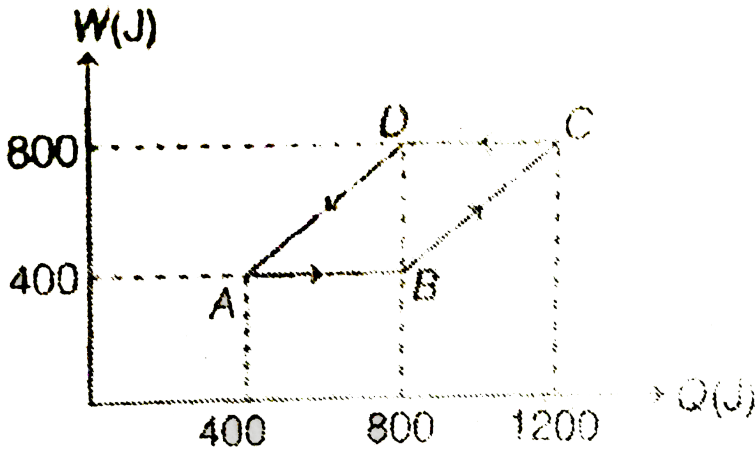

Choose incorrect statement:

- A. Magnitude of temperature change in the process AB and CD are same
- B. Process AB and CD are isochoric
- C. Process BC and DA are isothermal

D. Molar heat capacity in process AB is $\frac{5}{2} R$.

Answer: D

 [Watch Video Solution](#)

29. A metal block is placed in a room which is at $10^\circ C$ for long time. Now it is heated by an electric heater of power 500 W till its temperature becomes $50^\circ C$. Its initial rate of rise of temperature is $2.5^\circ C / \text{sec}$. The heater is switched off and now a heater of 100W is required to maintain the temperature of the block at $50^\circ C$. (Assume Newtons Law of cooling to be valid)

What is the heat capacity of the block?

A. $50J / ^\circ C$

B. $100J / ^\circ C$

C. $150J/^\circ C$

D. $200J/^\circ C$

Answer: D

 [Watch Video Solution](#)

30. A metal block is placed in a room which is at $10^\circ C$ for long time. Now it is heated by an electric heater of power 500 W till its temperature becomes $50^\circ C$. Its initial rate of rise of temperature is $2.5^\circ C/sec$. The heater is switched off and now a heater of 100W is required to maintain the temperature of the block at $50^\circ C$. (Assume Newtons Law of cooling to be valid)

What is the rate of cooling of block at $50^\circ C$ if the 100W heater is also switched off?

A. $5^\circ C / s$

B. $0.5^\circ C / s$

C. $1^\circ C / s$

D. $0.1^\circ C / s$

Answer: B



Watch Video Solution

31. Four moles of an ideal gas is initially in a state A having pressure $2 \times 10^5 N/m^2$ and temperature 200 K . Keeping pressure constant the gas is taken to state B at temperature of 400K. The gas is then taken to a state C in such a way that its temperature increases and volume decreases. Also from B to C, the magnitude of $\frac{dT}{dV}$ increases. The volume of gas at state C is

equal to its volume at state A. Now gas is taken to initial state A keeping volume constant. A total of 1000 J heat is rejected from the sample in the cyclic process. Take $R = 8.3 \text{ J/K/mol}$.

Which graph between temperature T and volume V for the cyclic process is correct.

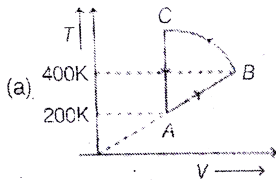

A.

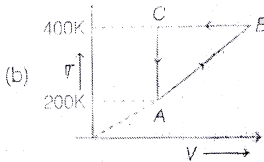

B.

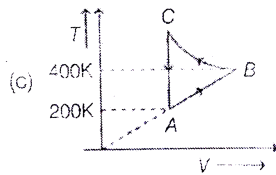

C.

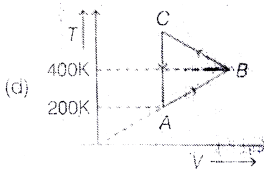

D.

Answer: C



Watch Video Solution

32. Four moles of an ideal gas is initially in a state A having pressure $2 \times 10^5 \text{ N/m}^2$ and temperature 200 K . Keeping pressure constant the gas is taken to state B at temperature of 400K. The gas is then taken to a state C in such a way that its temperature increases and volume decreases. Also from B to C, the magnitude of $\frac{dT}{dV}$ increases. The volume of gas at state C is equal to its volume at state A. Now gas is taken to initial state A keeping volume constant. A total of 1000 J heat is rejected from the sample in the cyclic process. Take $R = 8.3 \text{ J/K/mol}$.

The work done by the gas along path B to C is

A. 1000 J

B. -1000 J

C. $-7640J$

D. $5640J$

Answer: C

 [Watch Video Solution](#)

33. Two moles of a diatomic gas are carried through the cycle ABCDA as shown in figure. The segment AB represents an isothermal expansion, the segment BC an adiabatic expansion. The pressure and temperature at A are 5 atm and 600K respectively. The volume at B is twice that at A. The pressure at D is 1 atm.

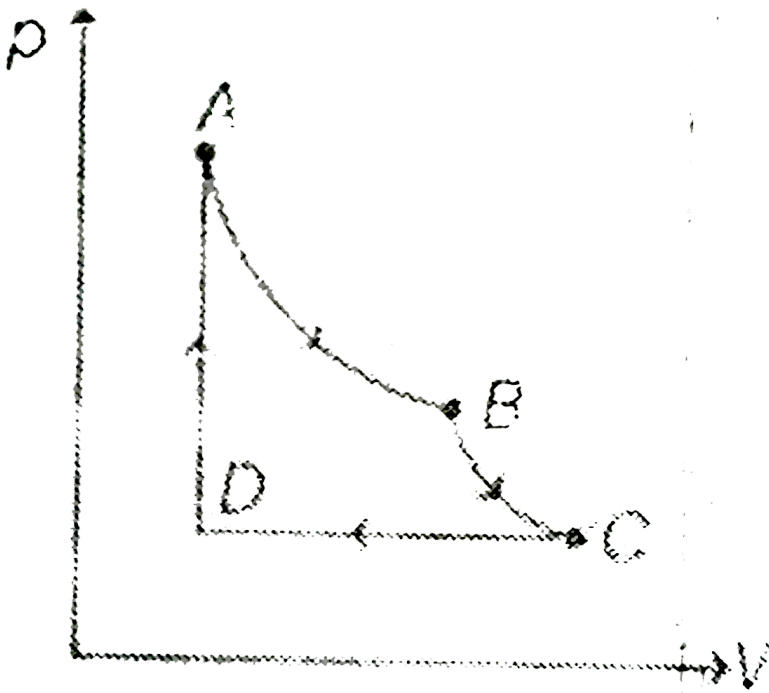

What is the pressure at B?

- A. 2.5 atm
- B. 3 atm
- C. 3.5 atm
- D. 2 atm

Answer: A



Watch Video Solution

34. Two moles of a diatomic gas are carried through the cycle ABCDA as shown in figure. The segment AB represents an isothermal expansion, the segment BC an adiabatic expansion. The pressure and temperature at A are 5 atm and 600K respectively. The volume at B is twice that at A. The pressure at D is 1 atm.

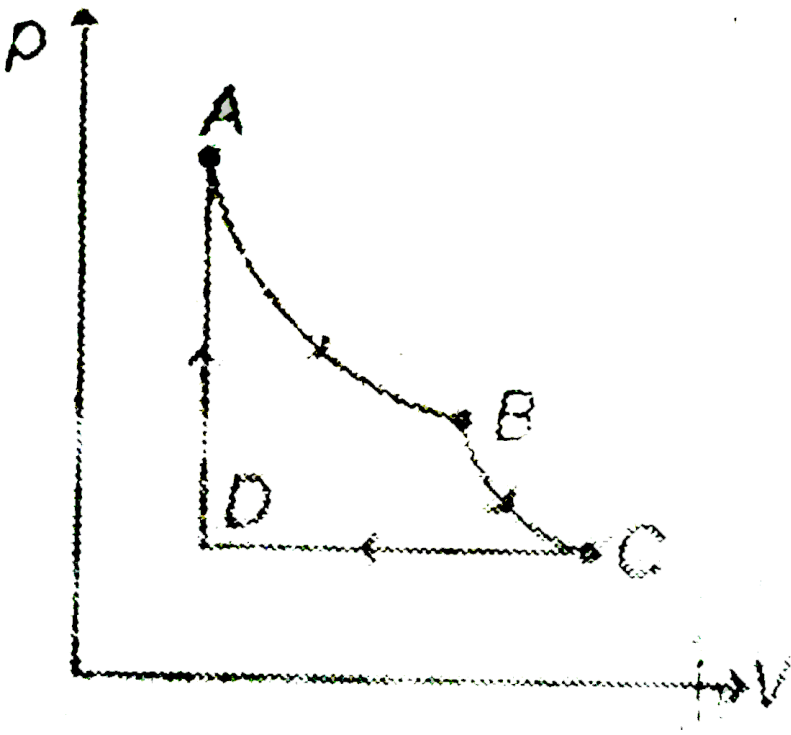

What is the temperature at C?

- A. $\frac{600}{(2.5)^{2/5}} K$
- B. $\frac{600}{(2.5)^{2/7}} K$
- C. $\frac{300}{(2.5)^{6/7}} K$
- D. $300K$

Answer: B



Watch Video Solution

35. Two moles of a diatomic gas are carried through the cycle ABCDA as shown in figure. The segment AB represents an isothermal expansion, the segment BC an adiabatic expansion. The pressure and temperature at A are 5 atm and 600K respectively. The volume at B is twice that at A. The pressure at D is 1 atm.

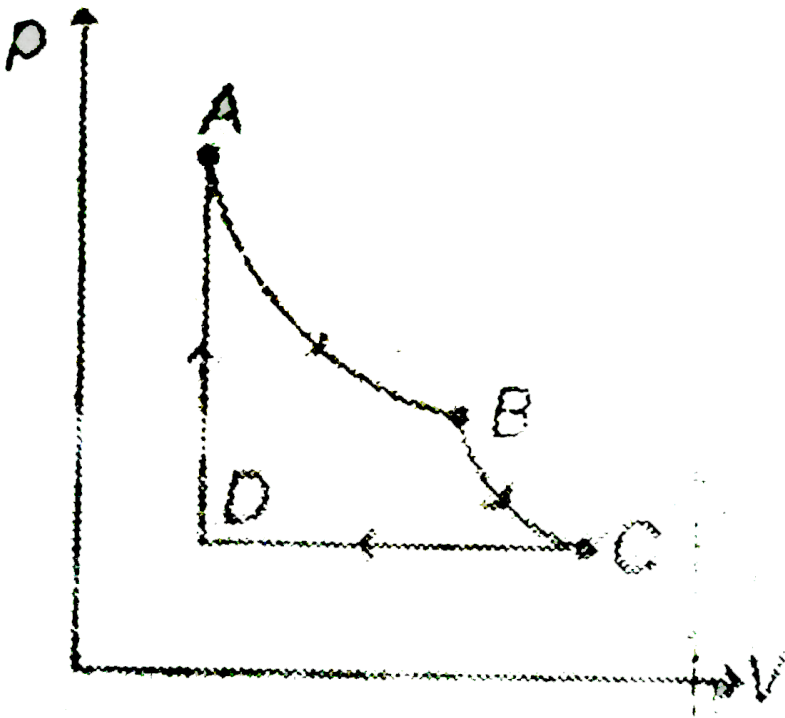

Find the T versus V graph of the above cyclic process.

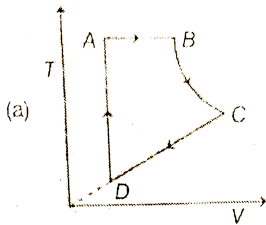

A.

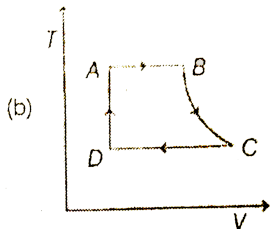

B.

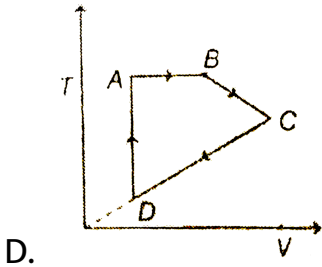
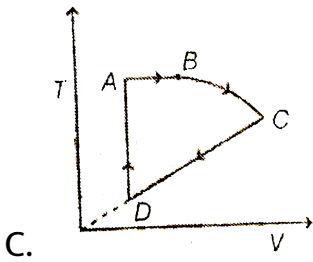

Answer: A

 [Watch Video Solution](#)

36. 2 moles of an ideal monoatomic gas undergoes a cyclic process ABCA as shown in the figure. R is the universal gas constant. (given $\ln 2 = 0.693$) Answer the following questions

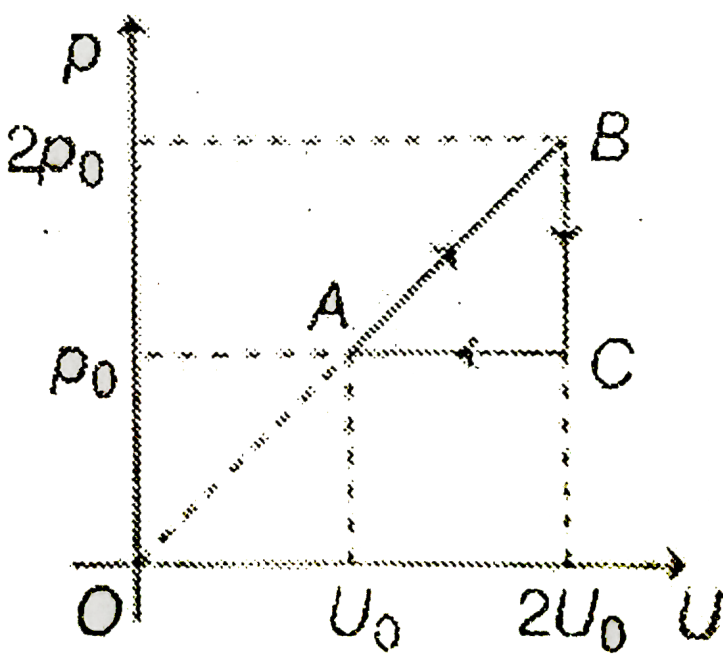

Graph of volume versus temperature of the cyclic proces ABCA is

- A. 10.38 %
- B. 13.2 %
- C. 40.38 %
- D. 25.2 %

Answer: B



Watch Video Solution

37. 2 moles of an ideal monoatomic gas undergoes a cyclic process ABCA as shown in the figure. R is the universal gas constant. (given $\ln 2 = 0.693$) Answer the following questions

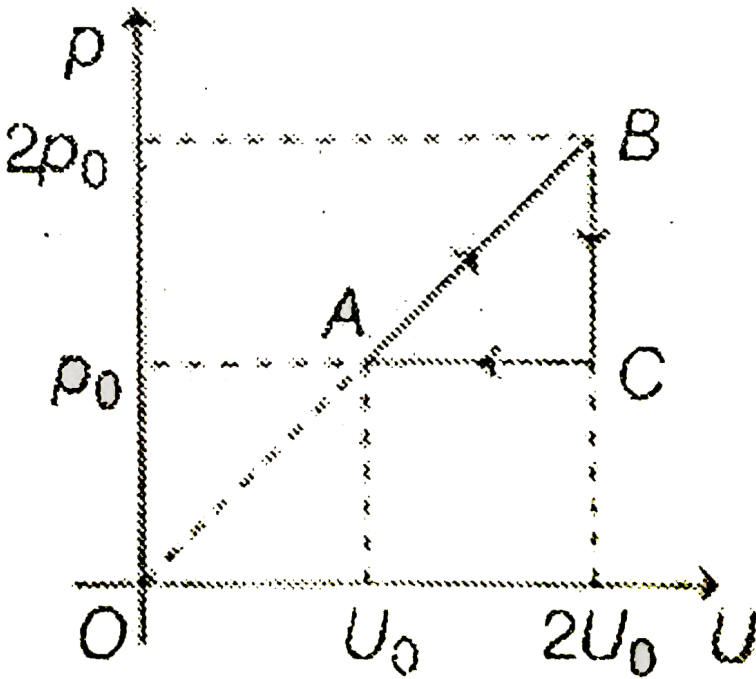

Graph of pressure versus volume of the cyclic process ABCA is

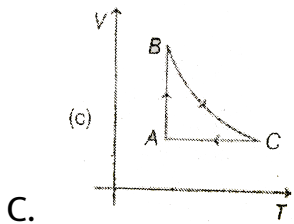
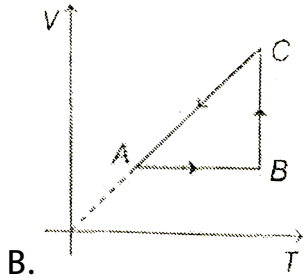
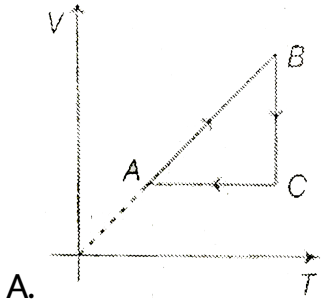

D. None of these

Answer: B

 **Watch Video Solution**

38. 2 moles of an ideal monoatomic gas undergoes a cyclic process ABCA as shown in the figure. R is the universal gas constant. (given $\ln 2 = 0.693$) Answer the following questions

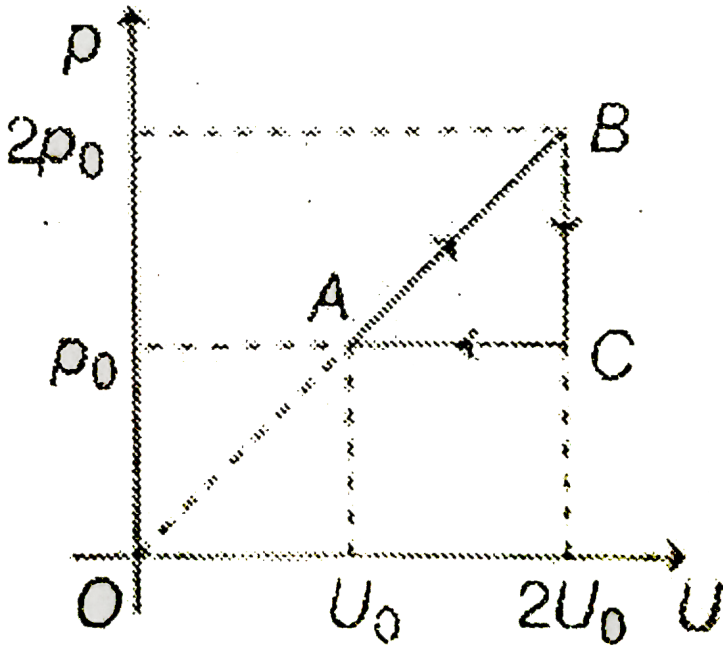

Graph of volume versus temperature of the cyclic process ABCA is

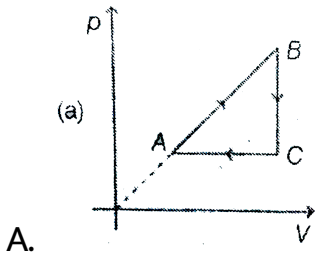

A.

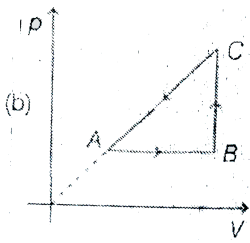

B.

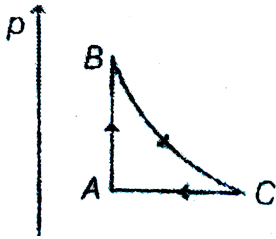

C.

D. None of these

Answer: C

 Watch Video Solution

39. One mole of helium gas follows the cycle 1-2-3-1 shown in the diagram. During process 3-1, the internal energy (U) of the gas depends on its volume (V) as $U = bV^2$, where b is a positive constant. If gas releases the amount of heat Q_1 during process

3-1 and gas absorbs th amount of heat Q_2 during process

$1 \rightarrow 2 \rightarrow 3$ them:

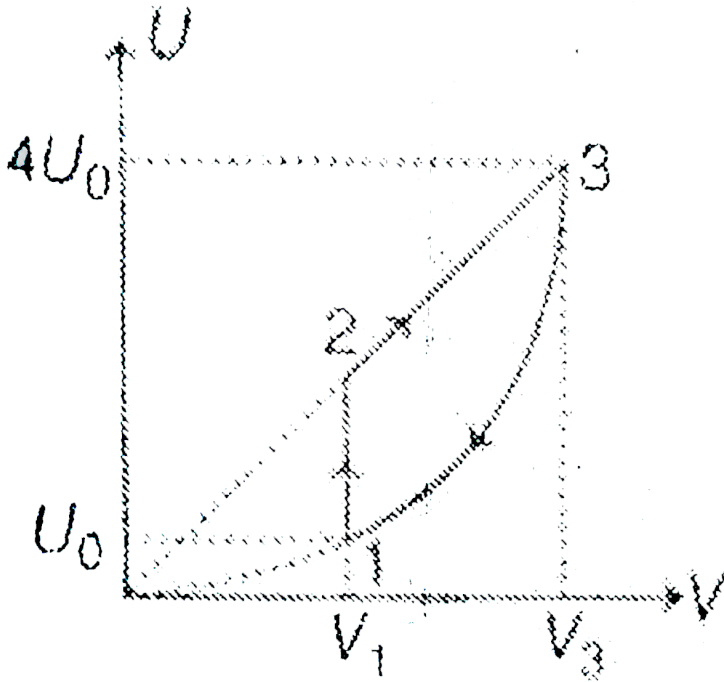

$\frac{V_3}{V_1}$ is

- A. $\frac{4}{3}$
- B. $\frac{2}{1}$
- C. $\frac{3}{2}$
- D. $\frac{4}{1}$

Answer: B



Watch Video Solution

40. One mole of helium gas follows the cycle 1-2-3-1 shown in the diagram. During process 3-1, the internal energy (U) of the gas depends on its volume (V) as $U = bV^2$, where b is a positive constant. If gas releases the amount of heat Q_1 during process 3-1 and gas absorbs the amount of heat Q_2 during process 1 \rightarrow 2 \rightarrow 3 then:

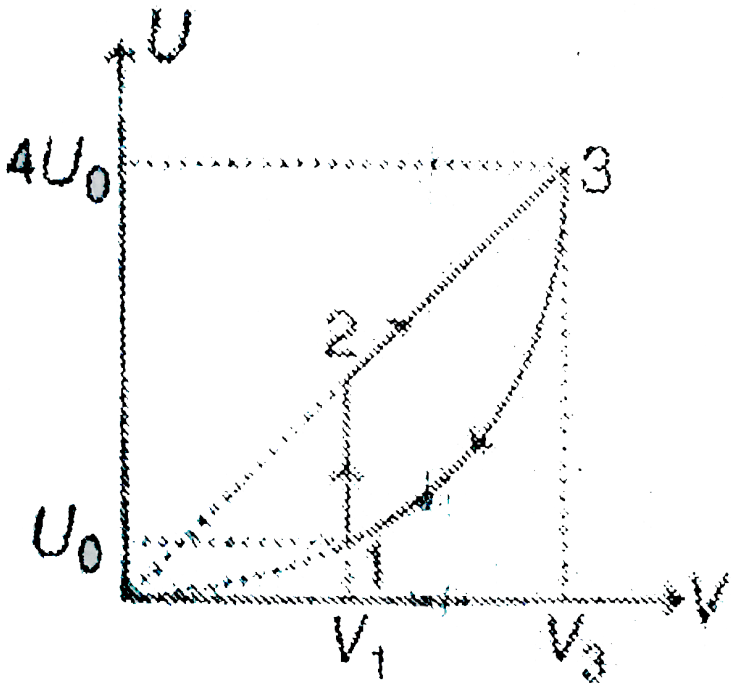

The value of O_1/Q_2 is

- A. $\frac{8}{9}$
- B. $\frac{9}{8}$
- C. $\frac{12}{13}$
- D. $\frac{13}{12}$

Answer: C



Watch Video Solution

Matrix Matching Type Questions

1. Match the following

Table-1	Table-2
(A) Specific heat	(P) $[ML^2 T^{-2} \theta^{-1}]$
(B) Boltzmann constant	(Q) $[MT^{-3} \theta^{-4}]$
(C) Wien's constant	(R) $[L\theta]$
(D) Stefan's constant	(S) $[L^2 T^{-2} \theta^{-1}]$



Watch Video Solution

2. In the p - T graph shown in figure, match the following.

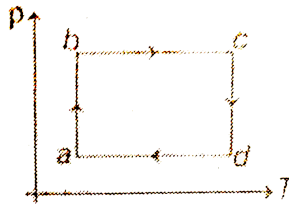

Table-1	Table-2
(A) Process a-b	(P) Isochoric process
(B) Process b-c	(Q) $\Delta U = 0$
(C) Process c-d	(R) P increasing
(D) Process d-a	(S) P decreasing

 Watch Video Solution

3. In process $T \propto \frac{1}{V}$, pressure of the gas increases from p_0 to $4p_0$. Match the following.

Table-1	Table-2
(A) Temperature of the gas	(P) Positive
(B) Volume of the gas	(Q) Negative
(C) Work done by the gas	(R) Two times
(D) Heat supplied to the gas	(S) Cannot say anything
	(T) None

 Watch Video Solution

4. Three liquids A, B and C having same specific heat and mass ,
 $2m$ and $3m$ have temperatures $20^{\circ}C$, $40^{\circ}C$ and $60^{\circ}C$
 respectively. Temperature of the mixture when

(MPP_PHY_C13_E01_274_Q01.png" width="80%")

 [Watch Video Solution](#)

5. For a monoatomic gas at temperature T , match the following.

Table-1

- (A) Speed of sound
- (B) RMS speed of gas molecules
- (C) Average speed of gas molecules
- (D) Most probable speed of gas molecules

Table-2

- (P) $\sqrt{\frac{2RT}{M}}$
- (Q) $\sqrt{\frac{8RT}{\pi M}}$
- (R) $\sqrt{\frac{3RT}{M}}$
- (S) $\sqrt{\frac{5RT}{3M}}$

 [Watch Video Solution](#)

6. Three rods of equal length of same material are joined to form an equilateral triangle ABC as shown in figure. Area of cross-section of rod AB is S , of rod BC is $2S$ and that of AC is S . Then match the following.

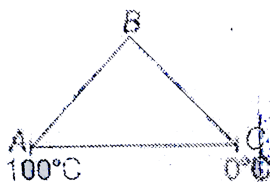

Table-1	Table-2
(A) Temperature of junction B	(P) Greater than 50°C
(B) Heat current in AB	(Q) Less than 50°C
(C) Heat current in BC	(R) Is equal to heat current in BC
	(S) Is $\frac{2}{3}$ times heat current in AC
	(T) None

 Watch Video Solution

7. Match the following.

Table-1

- (A) Cyclic Process
- (B) Isobaric Process
- (C) Isochoric Process
- (D) Adiabatic Expansion

Table-2

- (P) $\Delta U < 0$
- (Q) $\Delta Q = \Delta W$
- (R) $\Delta W = nR\Delta T$
- (S) $\Delta Q = \Delta U$



Watch Video Solution

8. Match the following.

Table-1

- (A) E in the equation, $p = \frac{2}{3} E$, is
- (B) $\ln U = 3RT$ for an ideal monoatomic gas U is
- (C) $\ln W = P(V_f - V_i)$, W is,
- (D) $\ln \Delta U = nC_V \Delta T$, ΔU is

Table-2

- (P) Change in internal energy in only isochoric process
- (Q) Translational kinetic energy of unit volume
- (R) Internal energy of one mole
- (S) Work done in isobaric process
- (T) None



Watch Video Solution

9. In the V-T graph shown in figure match the following.

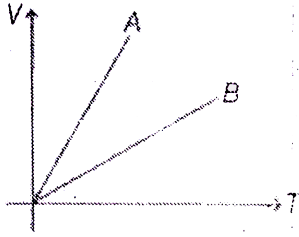

Table-1	Table-2
(A) Gas A and Gas B are	(P) monoatomic, diatomic
(B) p_A/p_B is	(Q) diatomic, monoatomic
(C) n_A/n_B is	(R) > 1
	(S) < 1
	(T) Cannot say any thing

 Watch Video Solution

10. For one mole of a monoatomic gas match the following.

Table-1		Table-2	
(A) Isothermal bulk modulus		(P) $\frac{RT}{V^2}$	
(B) Adiabatic bulk modulus		(Q) $\frac{5p}{3V}$	
(C) Slope of p - V graph in isothermal process		(R) $\frac{1}{V}$	
(D) Slope of p - V graph in adiabatic process		(S) $\frac{4T}{3V}$	
		(I) None	

 Watch Video Solution

11. Match the following.

Table-1		Table-2	
(A) Adiabatic expansion		(P) No work done	
(B) Isobaric expansion		(Q) Constant internal energy	
(C) Isothermal expansion		(R) Increase in internal energy	
(D) Isochoric process		(S) Decrease in internal energy	

 Watch Video Solution

12. Match the following.

Table-1	Table-2
(A) Adiabatic bulk modulus	(P) $\frac{p}{V}$
(B) Slope of p - V graph in isothermal process	(Q) $\frac{2}{\gamma - 1}$
(C) Degree of freedom	(R) γp
(D) Molar heat capacity at constant pressure divided by R	(S) $\frac{\gamma}{\gamma - 1}$



Watch Video Solution

13. An ideal monoatomic gas undergoes different types of processes which are described in Table-1. Match the

corresponding effects in Table-2. The letters have usual meaning.

Table-1	Table-2
(A) $p = 2V^2$	(P) If volume increases then temperature will also increase
(B) $pV^2 = \text{constant}$	(Q) If volume increases then temperature will decrease.
(C) $C = C_V + 2R$	(R) For expansion, heat will have to be supplied to the gas.
(D) $C = C_V - 2R$	(S) If temperature increases then work done by gas is positive.



Watch Video Solution

14. The figures given below show different processes (relating pressure P and volume V) for a given amount of an ideal gas. W

is work done by the gas and ΔQ is heat absorbed by the gas.

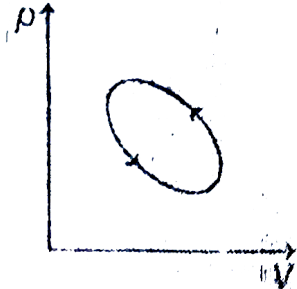
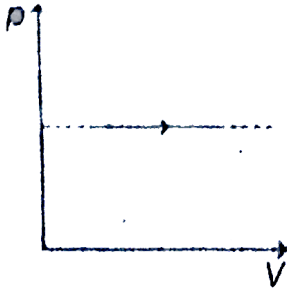
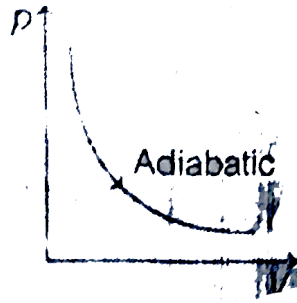
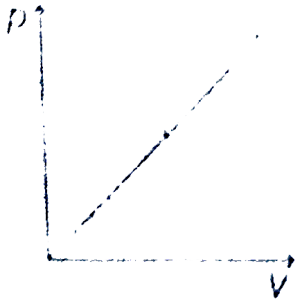

Table-1

Table-2

(A) In Fig. (i)

(B) In Fig. (ii)

(C) In Fig. (iii)

(D) In Fig. (iv)

(P) $\Delta Q > 0$

(Q) $W < 0$

(R) $\Delta Q < 0$

(S) $W > 0$

 Watch Video Solution

15. Match the following two tables.

Table-1	Table-2
(A) Coefficient of linear expansion	(P) Cal/°C
(B) Water equivalent	(Q) gm
(C) heat capacity	(R) (°)
(D) Specific heat	(S) °C



Watch Video Solution

16. A rod AB of uniform cross-section consists of 4 sections AC, CD, DE and EB of different metal with thermal conductivities K , 0.8 , $1.2K$ and 1.5 respectively. Their lengths are respectively L , $1.2L$, $1.5L$ and $0.6L$. They are jointed rigidly in Succession at C, D and E to form the rod AB. The end A is maintained at $100^\circ C$ and the end B is maintained at $0^\circ C$. The steady state temperatures at the joints C, D and E are respectively T_C , T_D and

T_E Match the following two columns

Table-1	Table-2 (in $^{\circ}\text{C}$)
(A) $(T_A - T_C)$	(P) 9.6
(B) $(T_C - T_D)$	(Q) 30.1
(C) $(T_D - T_E)$	(R) 24.1
(D) $(T_E - T_A)$	(S) 38.2

 **Watch Video Solution**

17. An ideal monoatomic gas is taken through one of the following reversible processes expressed by the equation in Table-1. Match the molar heat capacity of the gas, expressed in multiples of R, in Table-2 with the appropriate process:

Table-1	Table-2
(a) $pV^{5/3} = \text{constant}$	(P) $\frac{5}{2}R$
(b) $1/V^2 = \text{constant}$	(Q) $\frac{3}{2}R$
(c) $V = \text{constant}$	(R) R
(d) $p = \text{constant}$	(S) Zero



Watch Video Solution

18. There are two types of rods :

Rod 1 : Length L , Thermal conductivity D , Area of cross section A

Rod 2 : Length $2L$, Thermal conductivity K , Area of cross section A

Four possible arrangements of these rods in steady state are shown in Table-1 and Table-2 gives the temperature of the junction. Match

Table-1 with Table-2

Table-1

Table-2

(A)



(P) 20°C

(B)

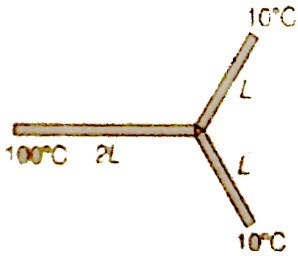

(Q) 27.5°C

(C)

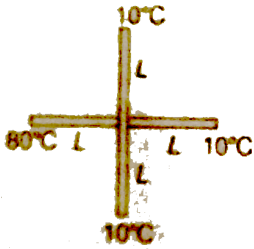

(R) 28°C

(D)

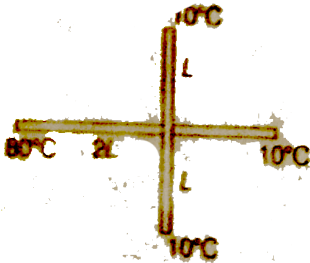

(S) 40°C



Watch Video Solution

Integer Type Questions

1. The energy of the rotational motion of the molecules in n moles of nitrogen at temperature of T K is $x nRT$. Find the value of x .

 [Watch Video Solution](#)

2. Two moles of a diatomic ideal gas is taken through $pT = \text{constant}$. Its temperature is increased from T to $2T$. Find the work done by the system?

 [Watch Video Solution](#)

3. Two identical containers joined by a small pipe initially contain the same gas at pressure p_0 and absolute temperature T_0 . One container is now maintained at the same temperature while the other is heated to $2T_0$. The common pressure of the gas

 [Watch Video Solution](#)

4. One mole of a monoatomic gas is carried along process ABCDEA as shown in the diagram. The net work done by gas is $(0. x)J$. Find value of x .

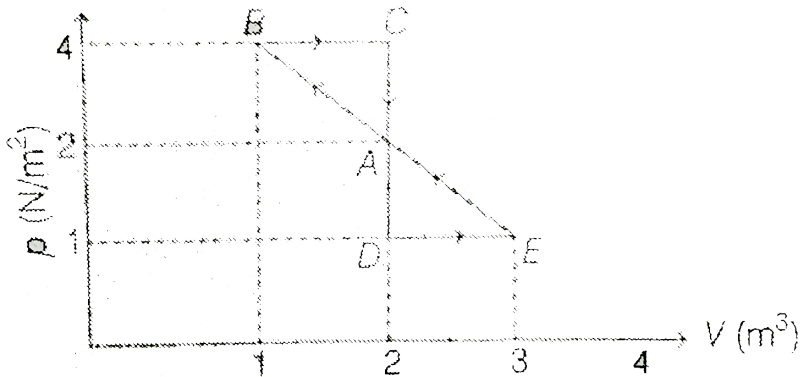

 [Watch Video Solution](#)

5. Corresponding to the process shown in figure, the heat given to the gas in the process ABCA is $(0.2x) J$. Find value of x .

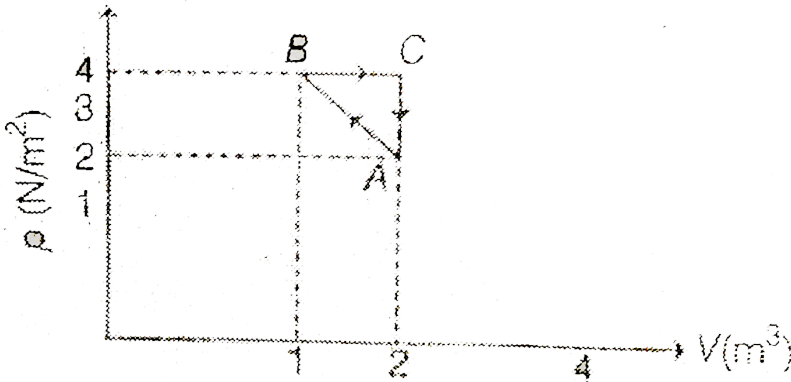

[▶ Watch Video Solution](#)

6. The internal energy of a gas is given by $U = 2pV$. It expands from V_0 to $2V_0$ against a constant pressure p_0 . The heat absorbed by the gas in the process is

[▶ Watch Video Solution](#)

7. An ideal monoatomic gas undergoes a process in which its internal energy U and density ρ vary as $U\rho = \text{constant}$. The ratio of change in internal energy and the work done by the gas is

 [Watch Video Solution](#)

8. Rate of heat flow through a cylindrical rod is H_1 . Temperatures of ends of rod are T_1 and T_2 . If all the dimensions of rod become double and temperature difference remains same and rate of heat flow becomes H_2 . Then $\frac{H_1}{H_2}$ is $0.x$. Find value of x .

 [Watch Video Solution](#)

9. Choose the correct option:

Two identical conducting rods are first connected independently to two vessels, one containing water at $100^{\circ}C$ and the other containing ice at $0^{\circ}C$. In the second case, the rods are joined end to end and connected to the same vessels. Let q_1 and q_2 gram per second be the rate of melting of ice in the two cases respectively. The ratio $\frac{q_1}{q_2}$ is:

A. (a) $\frac{1}{2}$

B. (b) $\frac{2}{1}$

C. (c) $\frac{4}{1}$

D. (d) $\frac{1}{4}$

Answer: D



Watch Video Solution

10. One mole of a monatomic gas is involved in the cyclic process as shown in the PV graph. Extension of the line segments 1-2 and 3-4 pass through the origin and the curves 4-1 and 2-3 are isotherms. Find the ratio $\frac{V_3}{V_2}$ if $\frac{V_2}{V_1} = 2$.

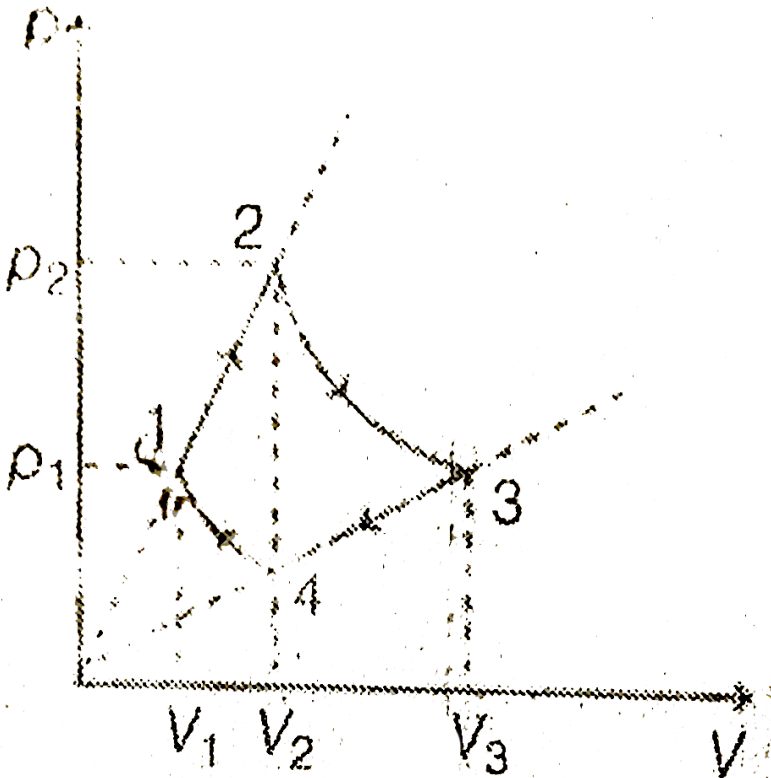

[Watch Video Solution](#)

11. Figure shows a parabolic graph between T and $\frac{1}{V}$ (T = temperature, V = Volume) for a gas undergoing an adiabatic process. If the ratio of rms velocity of molecules and speed of sound in the gas at the same temperature is \sqrt{n} , then find the value of n .

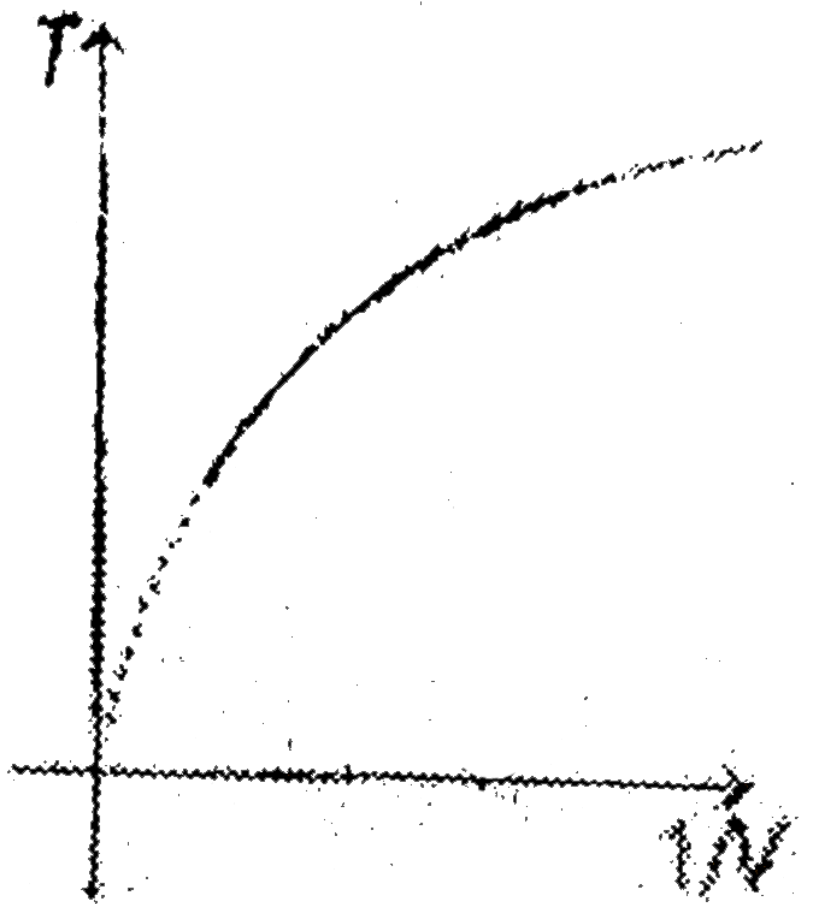



Watch Video Solution

12. Consider the adjacent figure. A piston divides a cylindrical container into two equal parts. The left part contains 1 mole of helium gas and the right part contains two moles of oxygen gas. The initial temperatures and pressures of the gases in the left chamber are T_0 and p_0 and the right chamber are $\frac{T_0}{2}$ and p_0 respectively as shown in the figure. The piston as well as the walls of the container are adiabatic. After removal of the piston, gases mix homogeneously and the final pressure becomes

$$p = \frac{4n}{13} p_0. \text{ Find the value of } n.$$

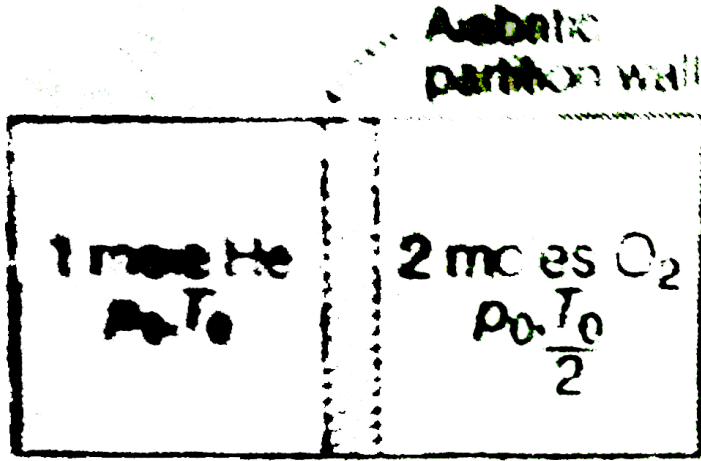

[▶ Watch Video Solution](#)

13. A black body emits maximum radiation of wavelength λ_1 at a certain temperature T_1 . On increasing the temperature, the total energy of radiation emitted is increased 16 times at temperature T_2 . If λ_2 is the wavelength corresponding to which maximum radiation is emitted at temperature T_2 . Calculate the value of $\left(\frac{\lambda_1}{\lambda_2}\right)$.

[▶ Watch Video Solution](#)

14. Nine identical conducting rods are arranged as shown in the figure. The ends A and B are maintained at temperatures T_1 and T_2 . Calculate the ratio of rate of flow of heat across AD to that of EB in the given arrangement in steady state.

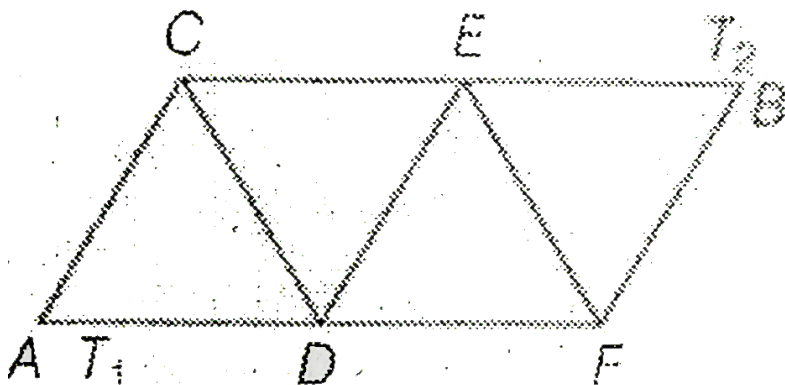

15. In steady state, rate of heat flow through rod of variable thermal conductivity shown in the figure is $Q = 6000$ W. Area of

cross section of rod in m^2 varies with x according as $A(x) = (1 - x)$, while temperature in Kelvin of rod is $T(x) = 300(1 - 4x - x^3)$. Find thermal conductivity (in watt/m-K) of rod at $x = 0$. (Thermal conductivity depends only on x).

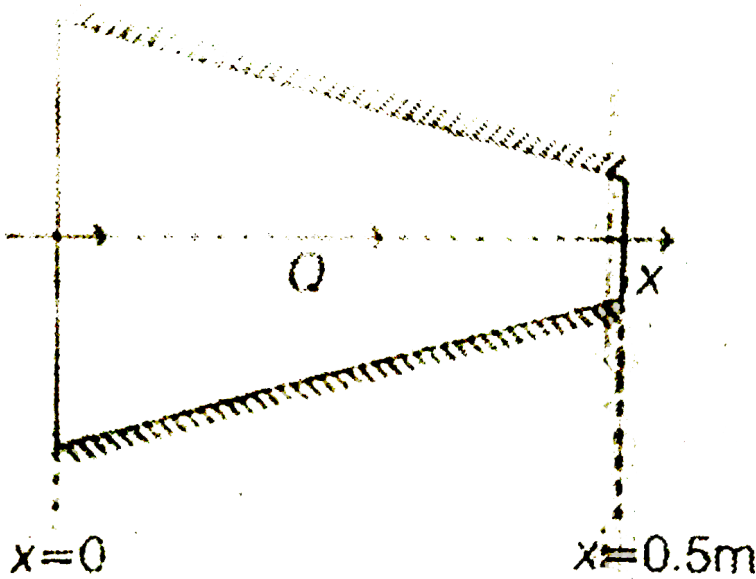

[Watch Video Solution](#)

16. The pressure and volume of an ideal gas are related as

$$P = \frac{a}{1 + \left(\frac{V}{b}\right)^3}, \text{ where 'a' and 'b' are constants. The}$$

translational kinetic energy due to the thermal motion of the gas sample at volume $V = b$, (given that $ab = 12 \text{ kJ}$) is $n \text{ kJ}$. Find n .



[Watch Video Solution](#)

17. An ideal monoatomic gas of one mole undergoes a cyclic process ADBCA as shown in figure. X and Y are two isothermal curves at temperature 211°C and 127°C respectively. If the work done by the gas in cyclic process is λR , then find the value

of λ . (R is the gas constant)

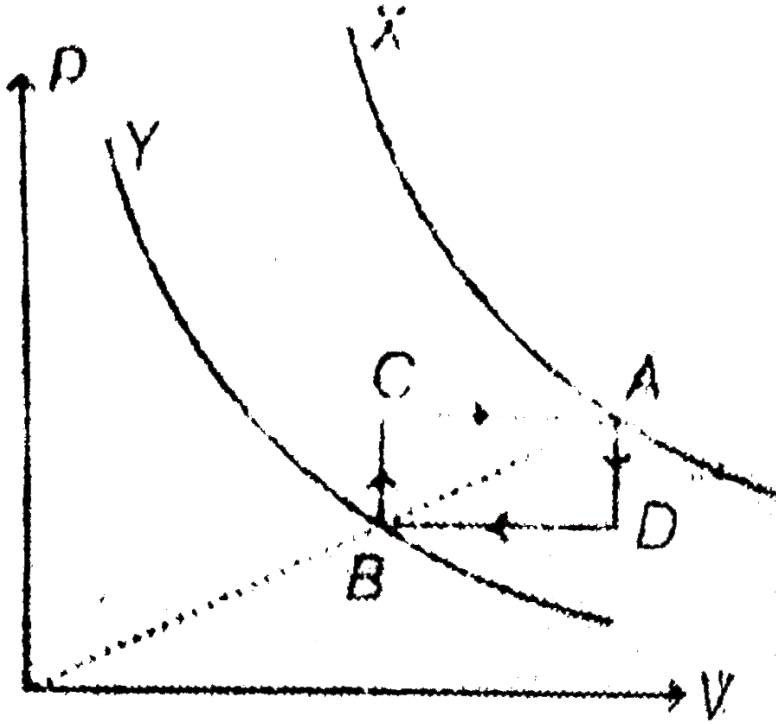

[▶ Watch Video Solution](#)

Others

1. The current density in a wire is $10A/cm^2$ and the electric field in the wire is $5V/cm$. If p = resistivity of material, σ = conductivity of the material then (in SI unit)

A. $p = 5 \times 10^{-3}$

B. $p = 200$

C. $\sigma = 5 \times 10^{-3}$

D. $\sigma = 200$

Answer: D



[Watch Video Solution](#)

2. A resistor of resistance R is connected to a cell internal resistance 5Ω . The value of R is varied from 1Ω to 5Ω . The power

consumed by R

- A. increases continuously
- B. decreases continuously
- C. first decreases then increases
- D. first increases then decreases

Answer: A



Watch Video Solution

3. Find the current through the $10(\Omega)$ resistor shown in figure.

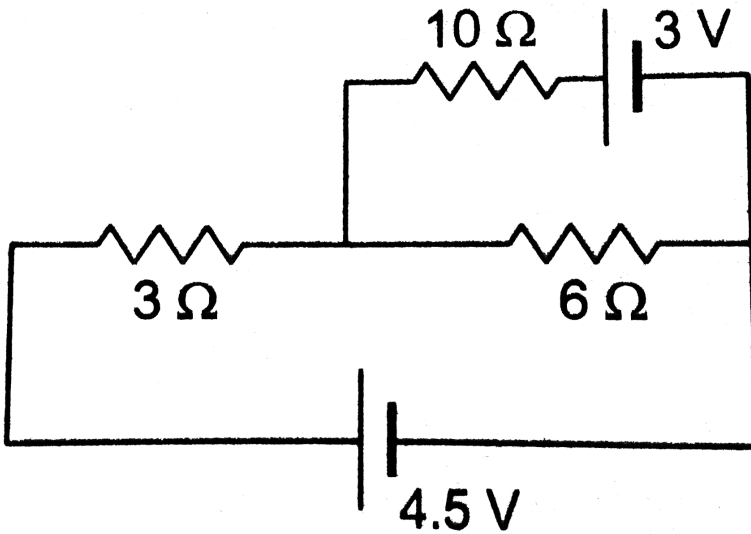

A. zero

B. 1A

C. 2A

D. 0.5A

Answer: A



Watch Video Solution

4. Each resistance shown in the network is in ohm. Current through the resistor 3Ω is 0.25 A. The input voltage 'V' is equal to

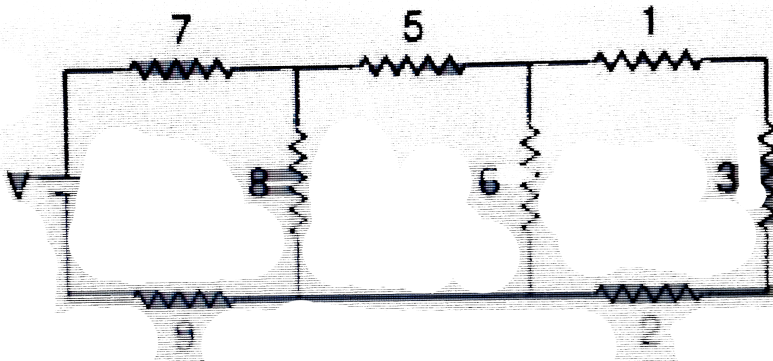

A. 10 V

B. 20 V

C. 5 V

D. $\frac{15}{2} V$

Answer: B

5. In the figure shown, each resistor is of 20Ω and the cell has emf 10 volt with negligible internal resistance. Then rate of joule heating in the circuit is (in watts)

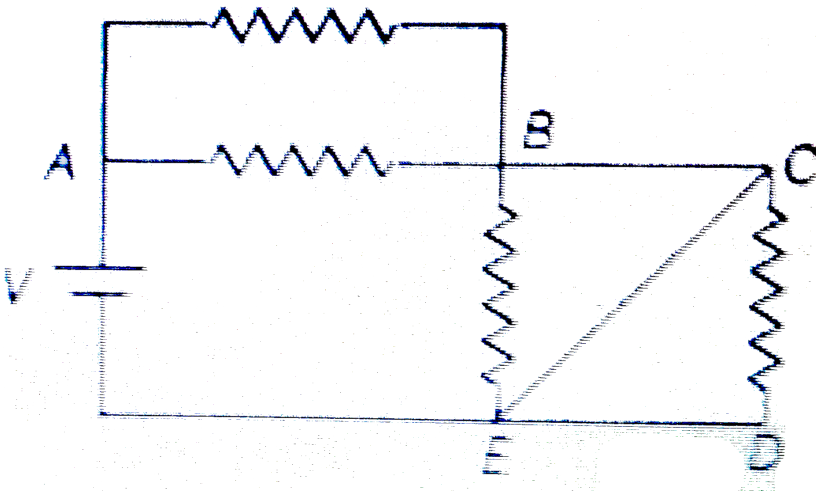

A. $\frac{20}{3}$

B. $\frac{40}{3}$

C. 10

D. zero

Answer: C

 Watch Video Solution

6. Four identical bulbs each rated 100 watt, 220 volts are connected across a battery as shown. The total electric power consumed by the bulbs is:

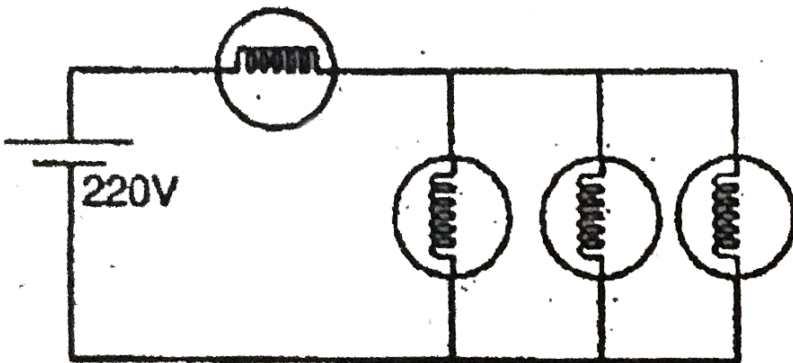

A. 75 watt

B. 400 watt

C. 300 watt

D. 150 watt

Answer: A

 [Watch Video Solution](#)

7. The reading of voltmeter is

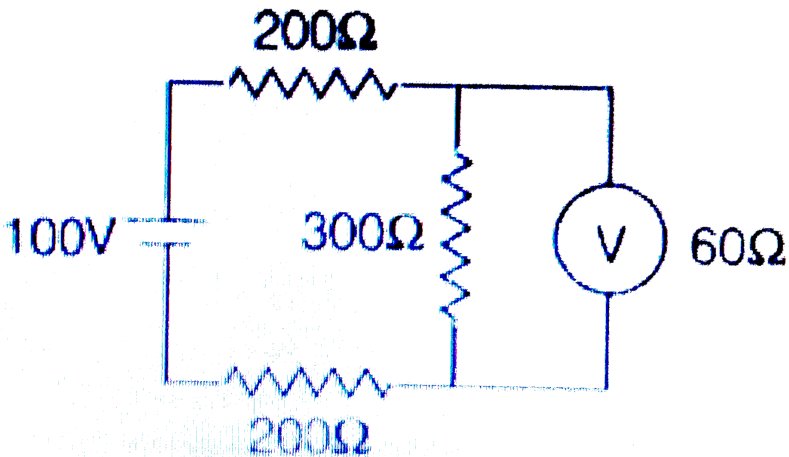

A. 50 V

B. 60 V

C. 40 V

D. None of these

Answer: D



[Watch Video Solution](#)

8. The ammeter shown in figure consists of a 480Ω coil connected in parallel to 20Ω shunt. Find the reading of the

ammeter

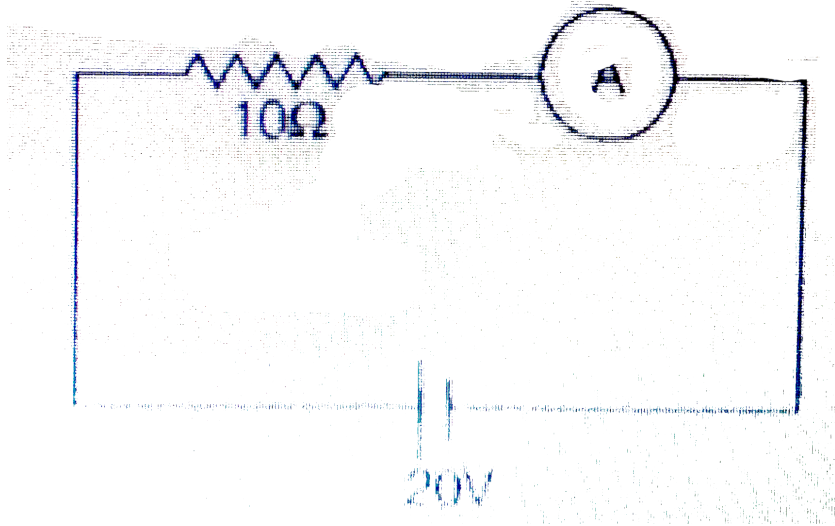

A. 0.68 A

B. 0.46 A

C. 1.32 A

D. 0.27 A

Answer: A

 [Watch Video Solution](#)

9. When a galvanometer is shunted with a 4Ω resistance, the deflection is reduced to one-fifth. If the galvanometer is further shunted with a 2Ω wire, determine current in galvanometer now if initially current in galvanometer is I_0 (given main current remains same).

A. $I_0/13$

B. $I_0/5$

C. $I_0/8$

D. $5I_0/13$

Answer: A

 [Watch Video Solution](#)

10. In the figure shown the current flowing $2R$ is:

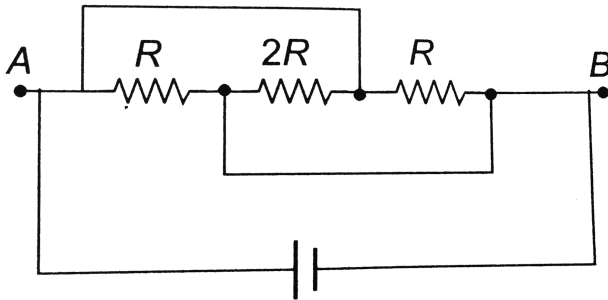

A. $\frac{V}{2R}$

B. from right to left

C. both are correct

D. both are wrong

Answer: C

 [Watch Video Solution](#)

11. The equivalent resistance between the points A and B is:

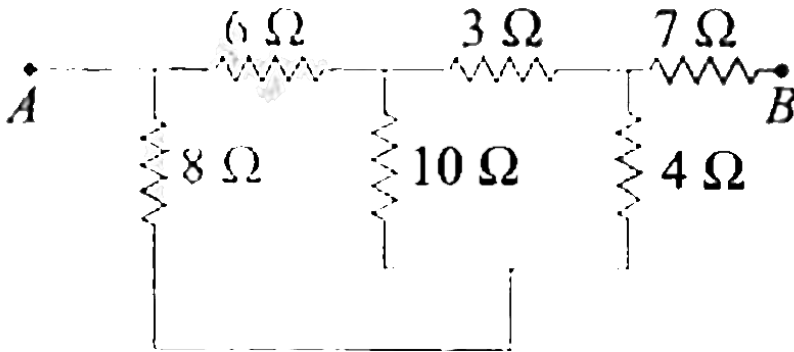

A. $\frac{36}{7}\ \Omega$

B. $10\ \Omega$

C. $\frac{85}{7}\ \Omega$

D. $18\ \Omega$

Answer: C

 Watch Video Solution

12. In the circuit shown, what is the potential different V_{PQ} ?

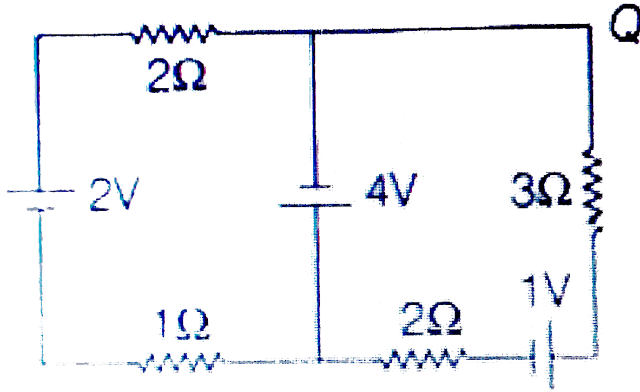

- A. $+3V$
- B. $+2V$
- C. $-2V$
- D. None of these

Answer: B

 [Watch Video Solution](#)

13. Which of the following wiring diagrams could be used to experimentally determine R using ohm's law? Assume an ideal voltmeter and an ideal ammeter.

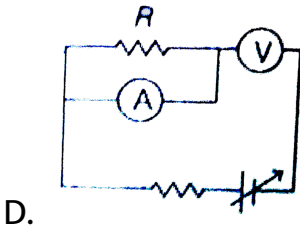
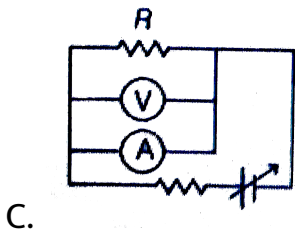
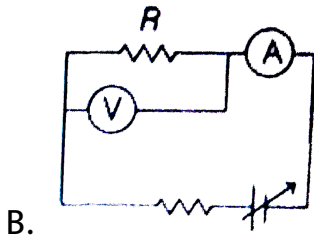
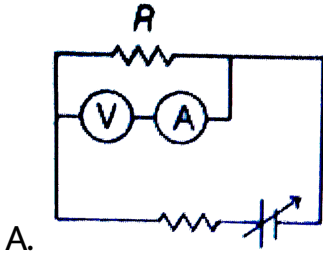

Answer: B

 Watch Video Solution

14. In the given circuit current flowing through the resistance 20Ω is $0.3A$, while the ammeter reads $0.8A$. What is the value of R_1

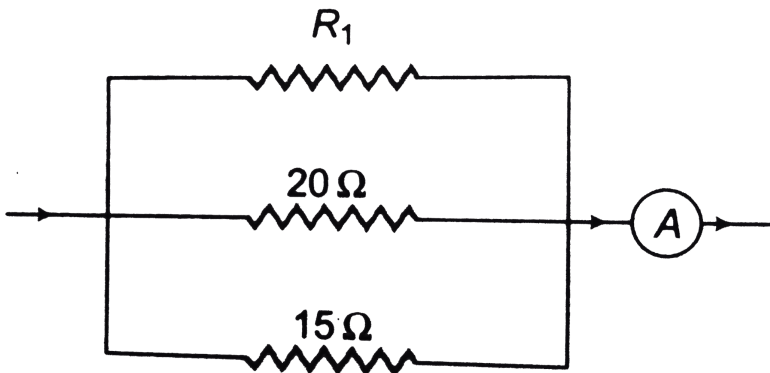

A. 30Ω

B. 40Ω

C. 50Ω

D. 60Ω

Answer: D



Watch Video Solution

15. Power generated across a uniform wire connected across a supply is H . If the wire is cut into n equal parts and all the parts are connected in parallel across the same supply, the total power generated in the wire is

A. $\frac{H}{n^2}$

B. $n^2 H$

C. nh

D. $\frac{H}{n}$

Answer: B

 [Watch Video Solution](#)

16. Rate of dissipation of Joule's heat in resistance per unit volume is (symbols have usual meaning)

A. σE

B. σJ

C. JE

D. None of these

Answer: C

 [Watch Video Solution](#)

17. The variation of current (I) and voltage (V) is as shown in figure A. The variation of power P with current I is best shown by which of the following graph

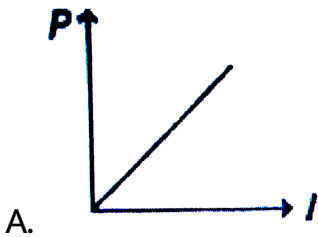
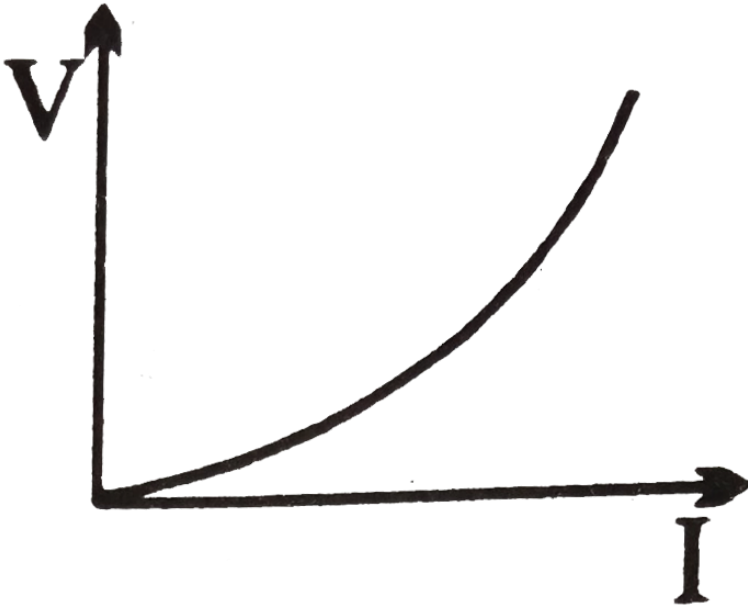

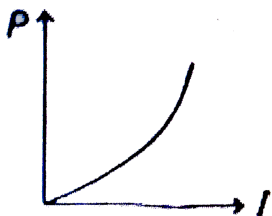

B.

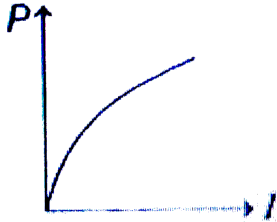

C.

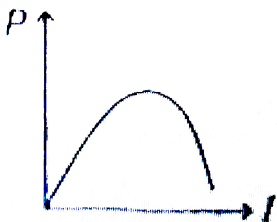

D.

Answer: B

 [Watch Video Solution](#)

18. Six resistors each of 10 ohm are connected shown. The equivalent resistance between points X and Y is

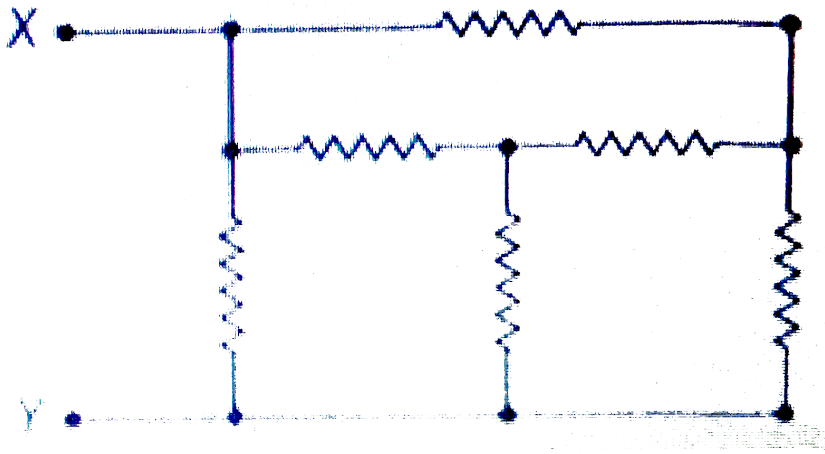

- A. 20Ω
- B. 5Ω
- C. $25/3\Omega$
- D. 10Ω

Answer: B



Watch Video Solution

19. Thirteen resistances each of resistance R ohm are connected in the circuit as shown in the figure below. The effective resistance between A and B is

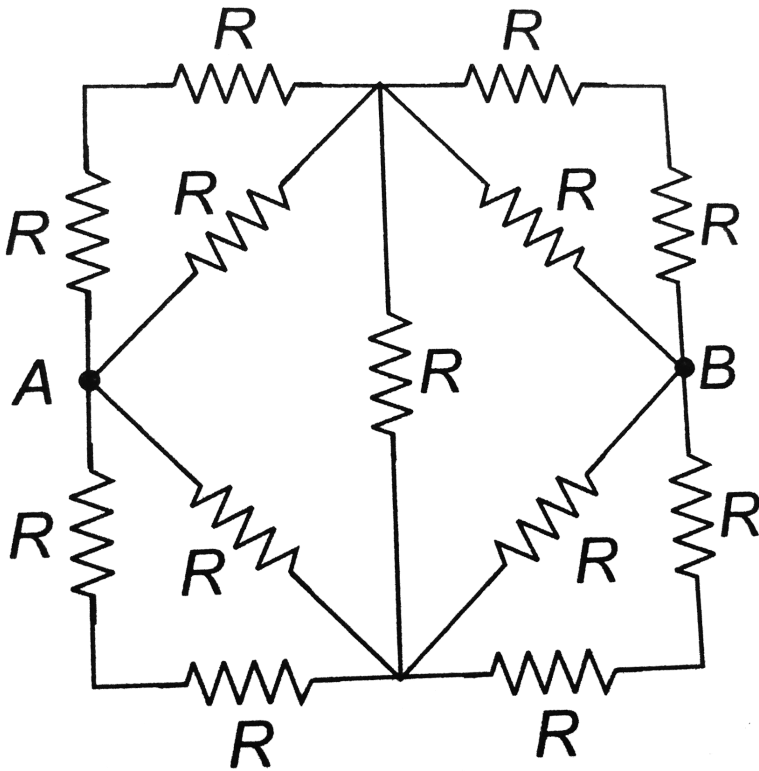

A. $2R$

B. $\frac{4R}{3}$

C. $\frac{2R}{3}$

D. R

Answer: C

 Watch Video Solution

20. In the given network, the equivalent resistance between A and B is

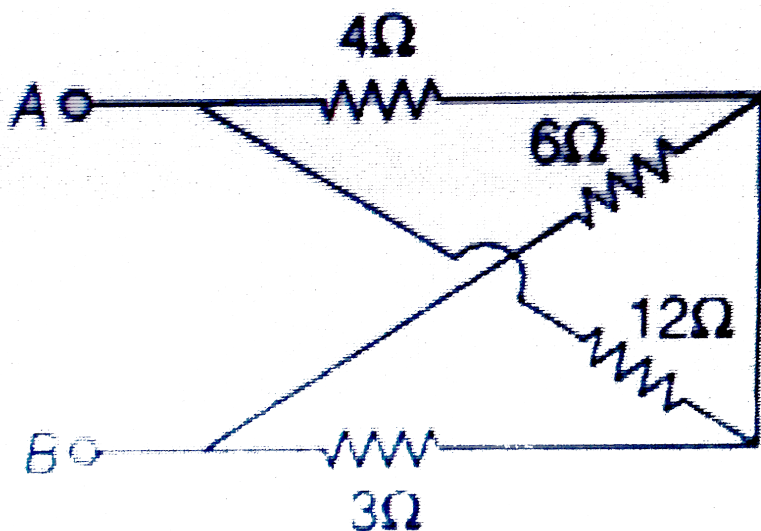

A. 6Ω

B. 16Ω

C. 7Ω

D. 5Ω

Answer: D

 Watch Video Solution

21. The equivalent resistance between points A and B

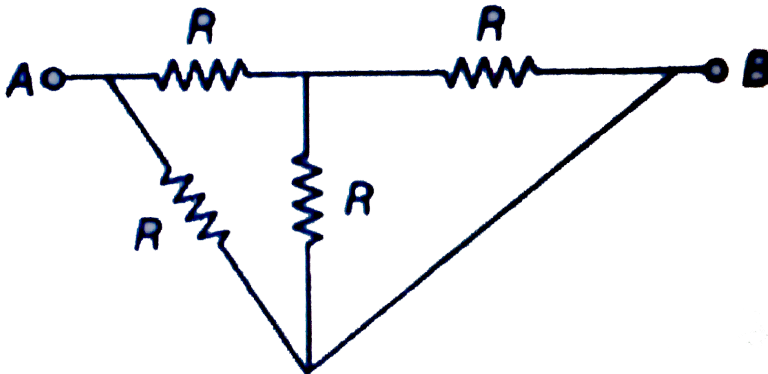

A. $2R$

B. $\frac{3}{4}R$

C. $\frac{4}{3}R$

D. $\frac{3}{5}R$

Answer: D



Watch Video Solution

22. A conductor with rectangular cross section has dimensions $(a \times 2a \times 4a)$ as shown in figure. Resistance across AB is x ,

across CD is y and across EF is z . Then

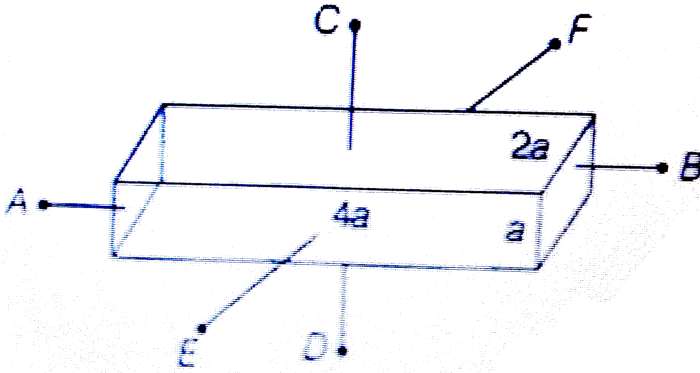

A. $x = y = z$

B. $x > y > z$

C. $y > z > x$

D. $x > z > y$

Answer: D

 [Watch Video Solution](#)

23. Which of the following has the maximum resistance?

A. Voltmeter

B. Milivoltmeter

C. Ammeter

D. Milimeter

Answer: B



[Watch Video Solution](#)

24. The length of a potentiometer wire is l . A cell of emf E is balanced at a length $l/3$ from the positive end of the wire. If the length of the wire is increased by $l/2$. At what distance will the same cell give a balance point.

A. $\frac{2l}{3}$

B. $\frac{l}{2}$

C. $\frac{l}{6}$

D. $\frac{4l}{3}$

Answer: B



Watch Video Solution

25. A cell develops the same power across two resistances R_1 and R_2 separately. The internal resistance of the cell is

A. $R_1 + R_2$

B. $\frac{R_1 + R_2}{2}$

C. $\sqrt{R_1 R_2}$

D. $\frac{\sqrt{R_1 R_2}}{2}$

Answer: C

 [Watch Video Solution](#)

26. Two wires of same dimension but resistivity p_1 and p_2 are connected in series. The equivalent resistivity of the combination is

A. $p_1 + p_2$

B. $\frac{1}{2}(p_1 + p_2)$

C. $\sqrt{p_1 p_2}$

D. $2(p_1 + p_2)$

Answer: B

 [Watch Video Solution](#)

27. Current passing through 3Ω resistance is

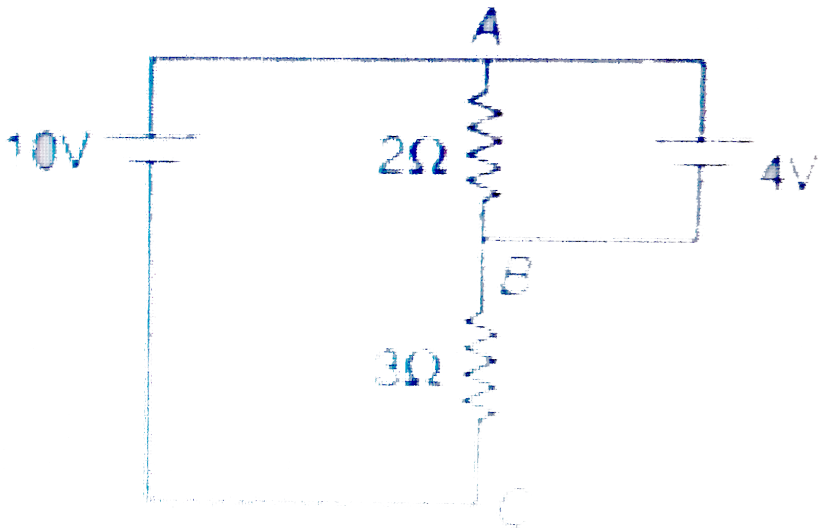

A. $\frac{14}{3} A$

B. $3A$

C. $2A$

D. $\frac{12}{5} A$

Answer: C

 Watch Video Solution

28. Current passing through 1Ω resistance is zero. Then the emf E is

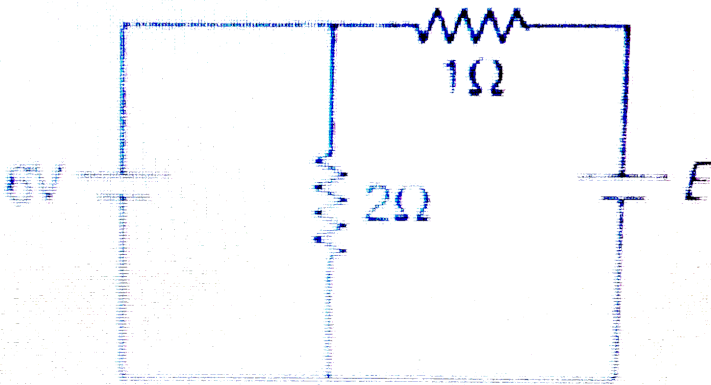

- A. $8V$
- B. $6V$
- C. $4V$
- D. $12V$

Answer: B

29. As the switch S is closed in the circuit shown in figure, current passed through it is

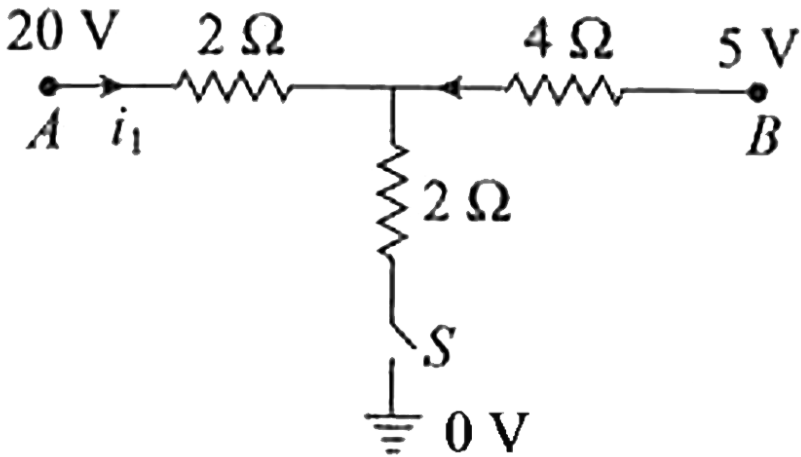

- A. 4.5 A
- B. 6.0 A
- C. 3.0 A
- D. zero

Answer: A

30. In the circuit shown in figure

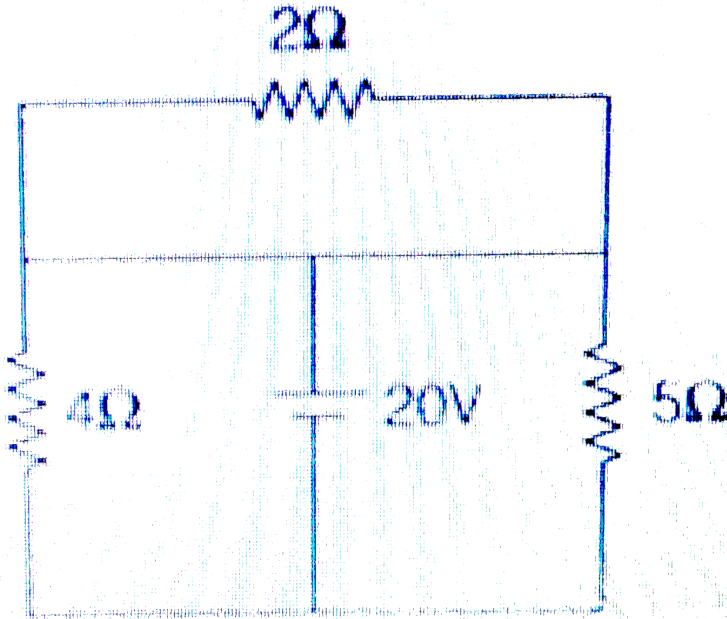

- A. current passing through 2Ω resistance is zero
- B. current passing through 4Ω resistance is 5 A
- C. current passing through 5Ω resistance is 4 A
- D. All of the above

Answer: D

 Watch Video Solution

31. Find equivalent resistance between A and B

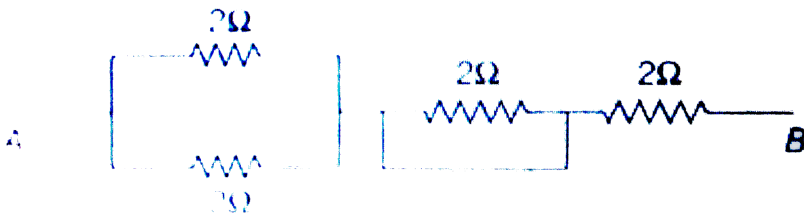

A. 5Ω

B. 3Ω

C. 2Ω

D. 8Ω

Answer: B

 Watch Video Solution

32. Two identical batteries, each having emf of 1.8 V and of equal internal resistances are connected as shown in the figure. Potential difference between A and B will be equal to (Ignore the resistance of lead wires)



A. 3.6 V

B. 1.8 V

C. zero

D. None of these

Answer: C

 Watch Video Solution

33. In the two circuits shown in figure

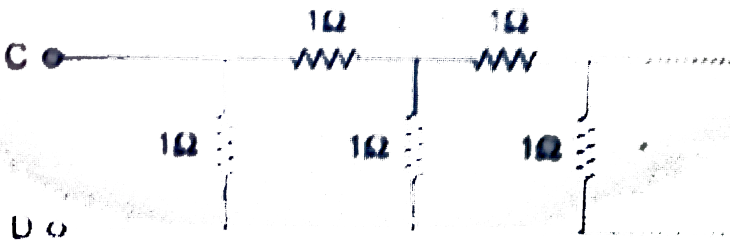
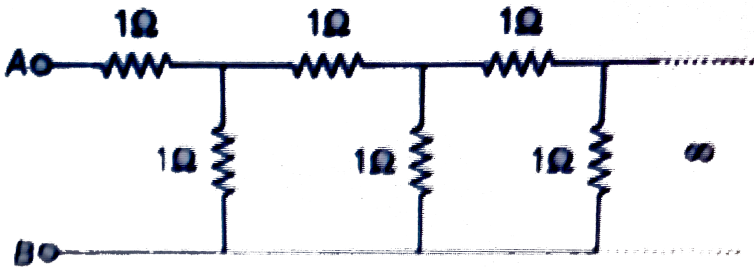

A. $R_{AB} = R_{CD} = (\sqrt{3} + 2)\Omega$

B. $R_{AB} = (\sqrt{3} + 1)\Omega$

C. $R_{CD} = (\sqrt{5} + 1)\Omega$

D. $R_{AB} > R_{CD}$

Answer: D

 **Watch Video Solution**

34. The net resistance between points P and Q in the circuit shown in figure is

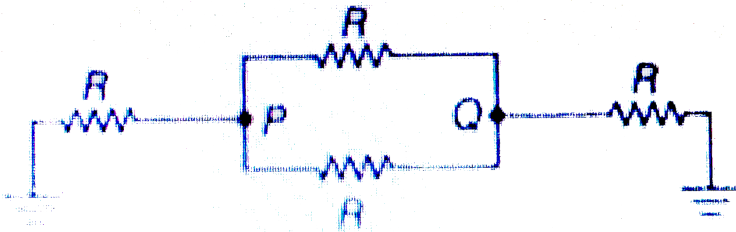

A. $R/2$

B. $2R/5$

C. $3R/5$

D. $R/3$

Answer: B

 **Watch Video Solution**

35. Current in 3Ω resistance is

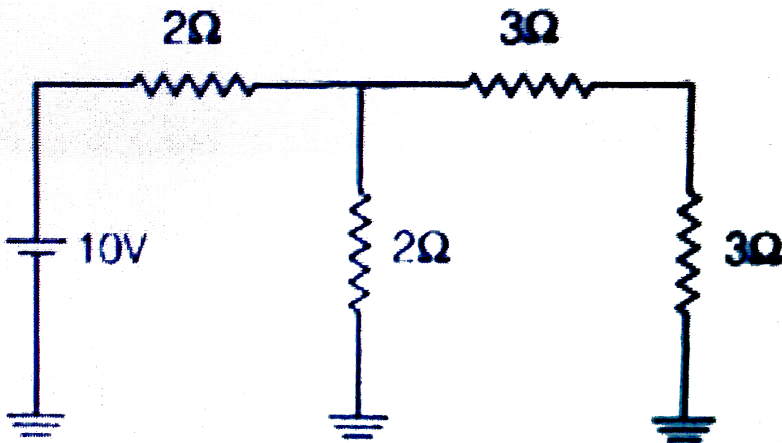

A. $1A$

B. $\frac{1}{7}A$

C. $\frac{5}{7}A$

D. $\frac{15}{7}A$

Answer: C

 [Watch Video Solution](#)

36. A galvanometer of resistance R_G is to be converted into an ammeter, with the help of a shunt of resistance R . If the ratio of the heat dissipated through galvanometer and shunt is 3:4, then

A. $R = \frac{3}{4}R_G$

B. $\frac{4}{3}R_G = R$

C. $\frac{9R}{16} = R_G$

D. $\frac{16R}{9} = R_G$

Answer: A

 Watch Video Solution

37. The equivalent resistance between points A and B

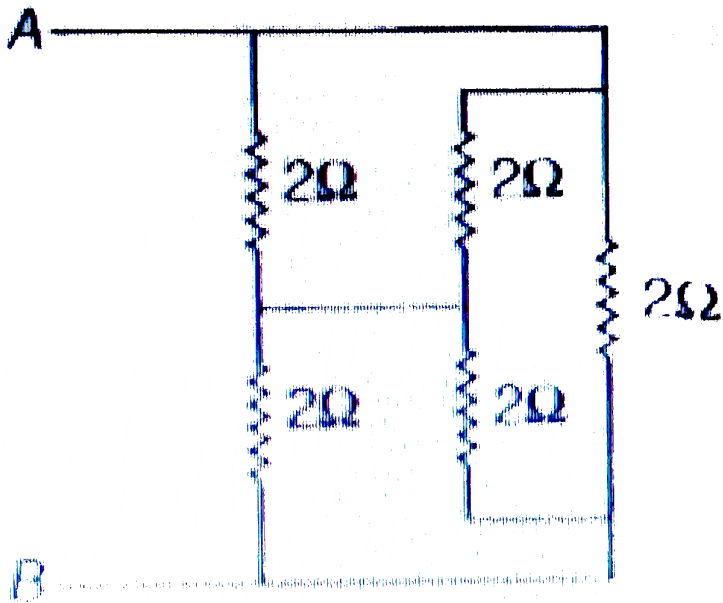

A. 2Ω

B. 4Ω

C. 1Ω

D. None of these

Answer: C

 [Watch Video Solution](#)

38. In the circuit shown in figure, each resistance is Net resistance between points A and B is

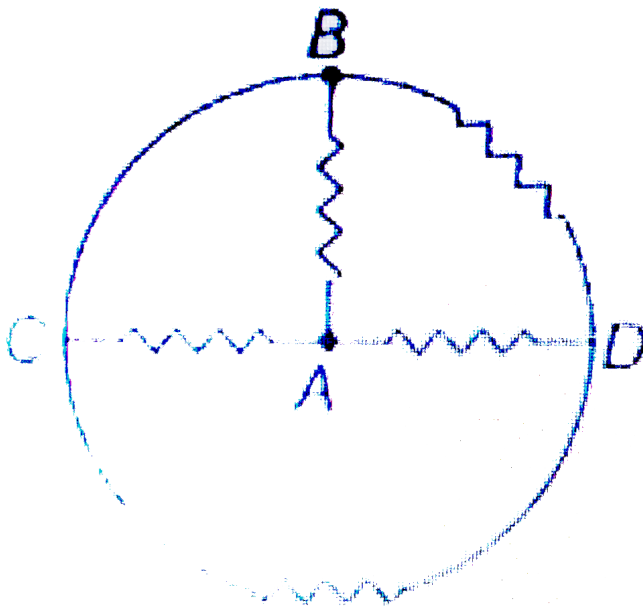

A. $\frac{4}{3}R$

B. $\frac{5}{3}R$

C. $R/2$

D. $\frac{7}{5}R$

Answer: C

[Watch Video Solution](#)

39. In the same figure, equivalent resistance between points A and D is

A. $\frac{R}{4}$

B. $2R$

C. R

D. $\frac{R}{2}$

Answer: D



[Watch Video Solution](#)

40. Each resistance of the circuit shown in figure is r . The equivalent resistance between A and B is

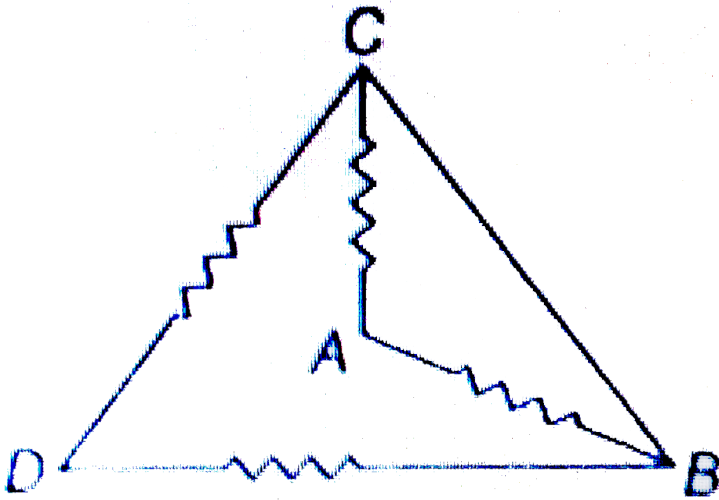

A. r

B. $r/4$

C. $r/2$

D. $5r/8$

Answer: C

 [Watch Video Solution](#)

41. As shown, the circuit is made of 8 different resistance. It is found that when $R_1 = 4\Omega$, the resistance between A and B is 2Ω . Now replace R_1 by a 6Ω resistor, what is the resistance between A and B ?

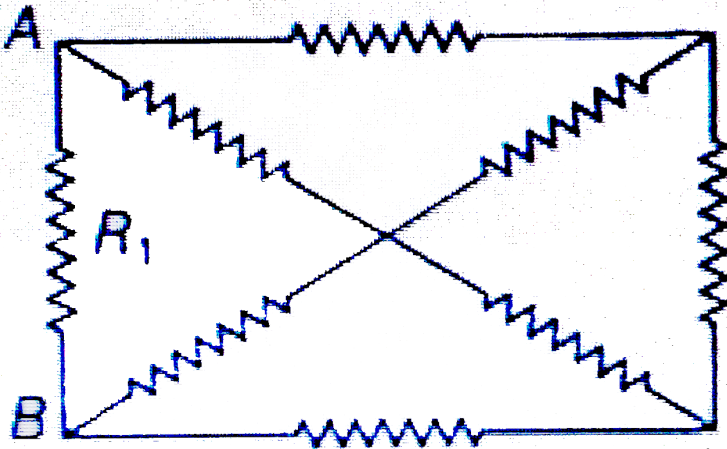

- A. 1
- B. 2
- C. 6
- D. 2.4

Answer: D

 Watch Video Solution

42. Resistance of each resistor is R . Then the equivalent resistance across A and B is

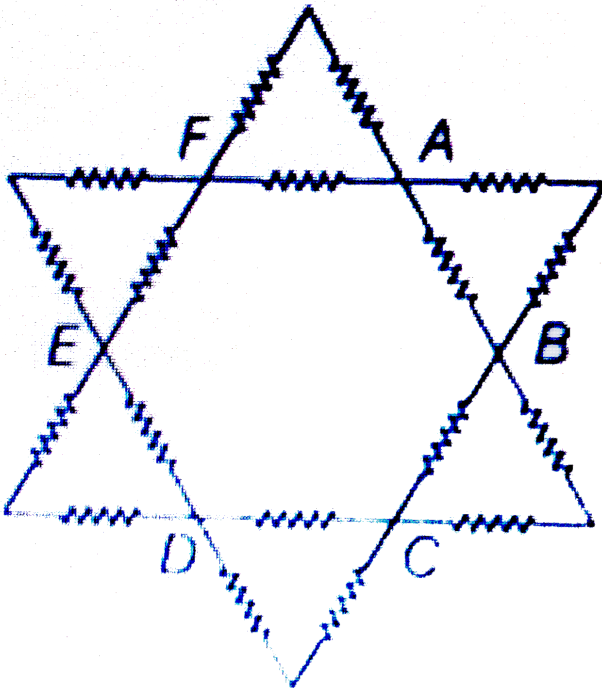

A. $\frac{5}{9}R$

B. $\frac{4}{9}R$

C. $\frac{R}{9}$

D. $\frac{7}{9}R$

Answer: A



Watch Video Solution

43. In the given circuit the power dissipated through resistance $R_1 = 9\Omega$ is P_1 , when switch S_1 is closed and S_2 is opened and the power dissipated through resistance $R_2 = 4\Omega$ is P_2 , when switch S_2 is closed and S_1 is opened. If $P_1 = P_2$, then r is equal

to :

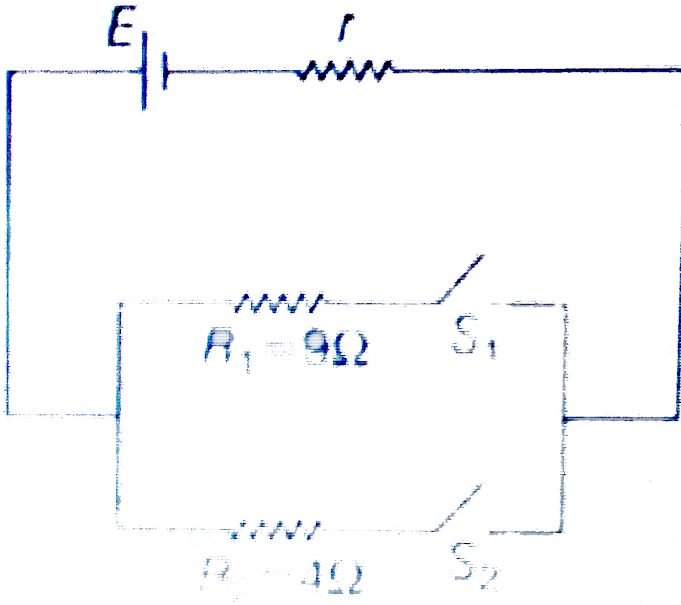

A. 2Ω

B. 6Ω

C. 4Ω

D. 3Ω

Answer: B



Watch Video Solution

44. A copper disc and a carbon disc of same radius are assembled alternately and co-axially to make a cylindrical conductor whose temperature coefficient of resistance is almost equal to zero. Ratio of thickness of the copper and the carbon disc is (neglect change in length. α_{CU} and $-\alpha_C$ represent the temperature coefficients of resistivities and ρ_{cu} carbon at room temperature respectively)

A. $\rho_C \alpha_C / \rho_{CU} \alpha_{CU}$

B. $\rho_{CU} \alpha_{CU} / \rho_C \alpha_C$

C. $\rho_C \alpha_{CU} / \rho_{CU} \alpha_C$

D. $\rho_{CU} \alpha_C / \rho_C \alpha_{CU}$

Answer: A



Watch Video Solution

45. Find equivalent resistance between A and B

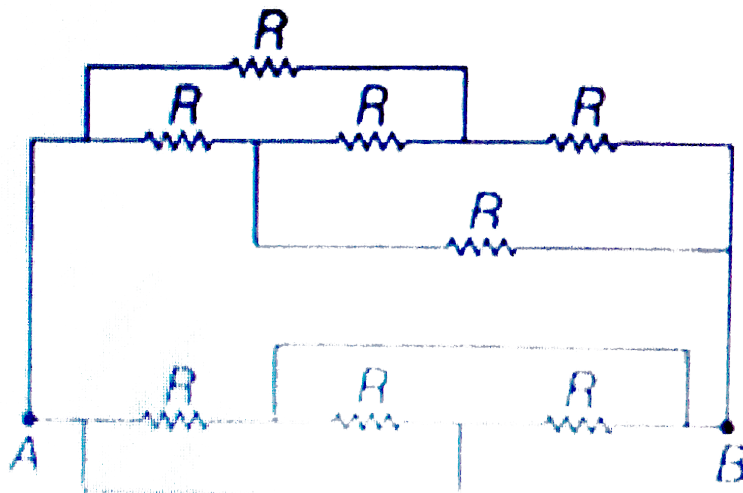

A. $\frac{R}{3}$

B. $\frac{R}{4}$

C. R

D. $\frac{R}{2}$

Answer: B

[Watch Video Solution](#)

46. Find equivalent resistance between A and D

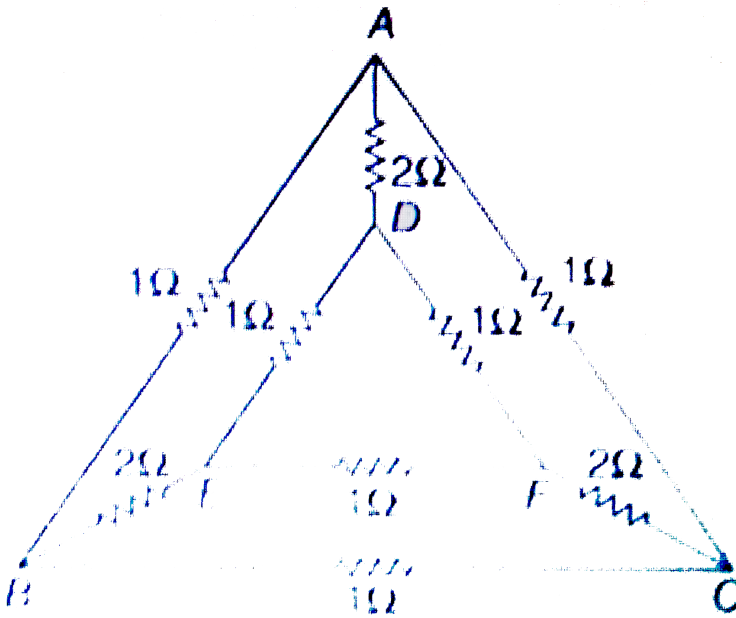

A. 2Ω

B. 3Ω

C. 1Ω

D. 5Ω

Answer: C

 Watch Video Solution

47. Calculate equivalent resistance between A and C

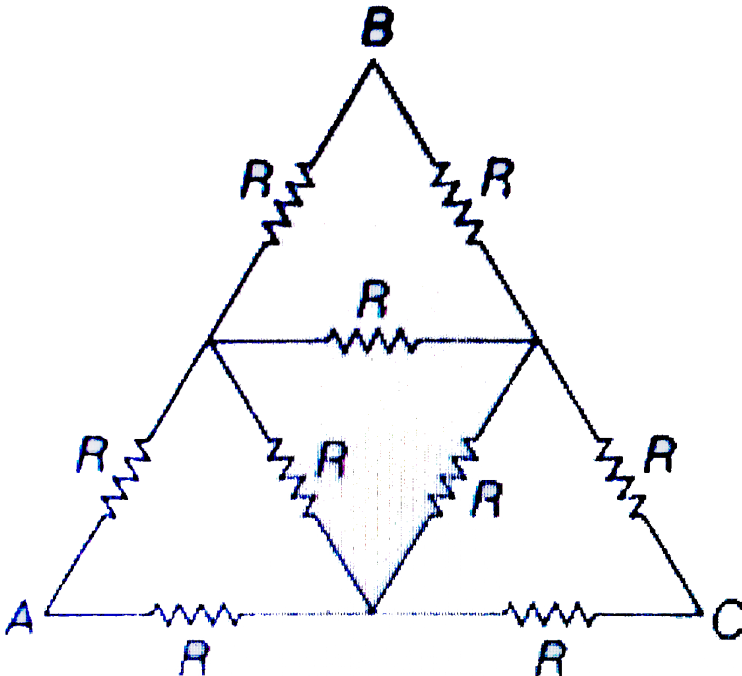

A. $\frac{10R}{8}$

B. $\frac{10R}{7}$

C. $\frac{10R}{9}$

D. $\frac{10R}{11}$

Answer: C

 Watch Video Solution

48. In the circuit shown below, V should be:

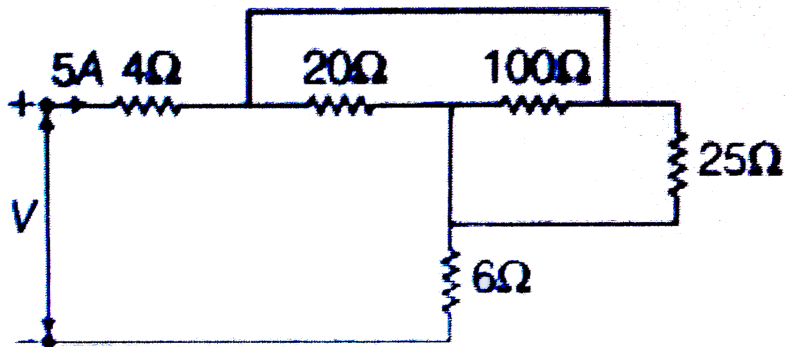

A. 50V

B. 100V

C. 75V

D. 25V

Answer: B

 [Watch Video Solution](#)

49. Equivalent resistance between A and B is

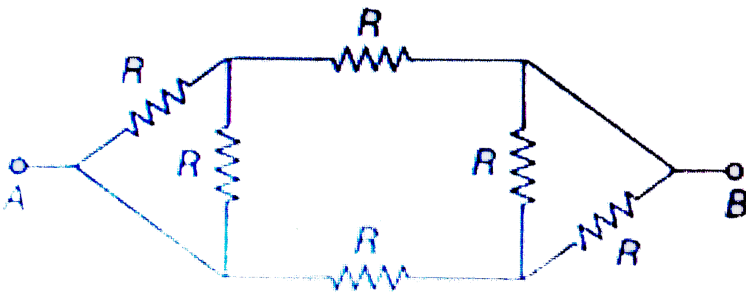

A. $\frac{3}{4}R$

B. $\frac{5}{3}R$

C. $\frac{7}{5}R$

D. R

Answer: A

 Watch Video Solution

50. In the circuit shown in figure, power developed across 1Ω , 2Ω and 3Ω resistance are in the ratio of

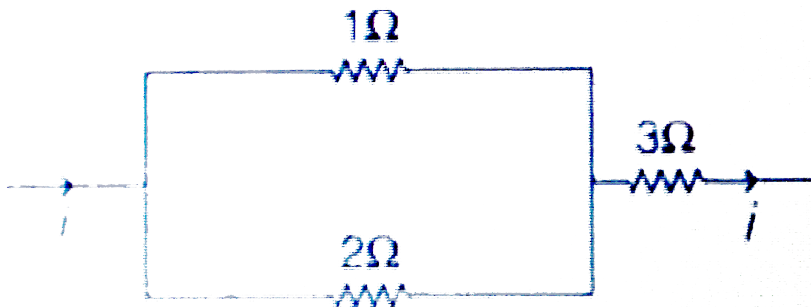

A. 1 : 2 : 3

B. 4: 2: 27

C. 6: 4: 9

D. 2: 1: 27

Answer: B

 [Watch Video Solution](#)

51. A moving coil galvanometer of resistance 20Ω gives a full scale deflection when a current of $1mA$ is passed through it. It is to be converted into an ammeter reading $20A$ on full scale. But the shunt of 0.005Ω only is available. What resistance should be connected in series with the galvanometer coil?

A. 80Ω

B. 5.94Ω

C. 9.45Ω

D. 12.62Ω

Answer: A

 [Watch Video Solution](#)

52. Maximum power developed across variable resistance R in the circuit shown in figure is

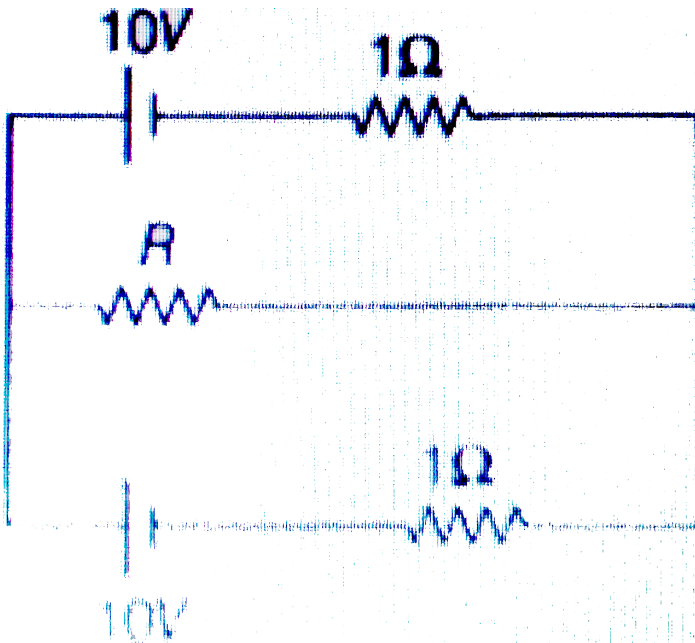

A. 50 W

B. 75 W

C. 25 W

D. 100 W

Answer: A



Watch Video Solution

53. Resistance of a resistor at temperature $t^\circ C$ is

$R_t = R_0(1 + \alpha t + \beta t^2)$, where R_0 is the resistance at $0^\circ C$. The

temperature coefficient of resistance at temperature $t^\circ C$ is

A. $\frac{a + 2bt}{1 + at + bt^2}$

B. $(a + 2bt)$

C. $\frac{1 + at + bt^2}{a + 2bt}$

D. constant

Answer: A

 Watch Video Solution

54. Potential different across the terminals of the battery shown in figure is

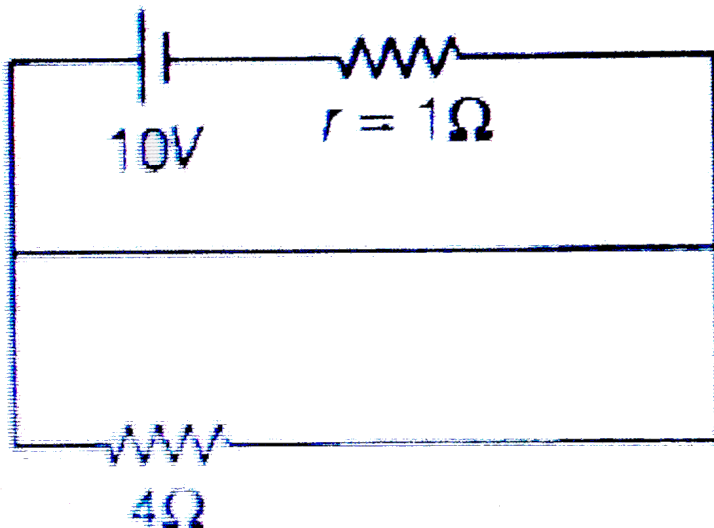

A. 8 V

B. 10 V

C. 6 V

D. zero

Answer: D

 Watch Video Solution

55. The emf of the battery shown in figure is

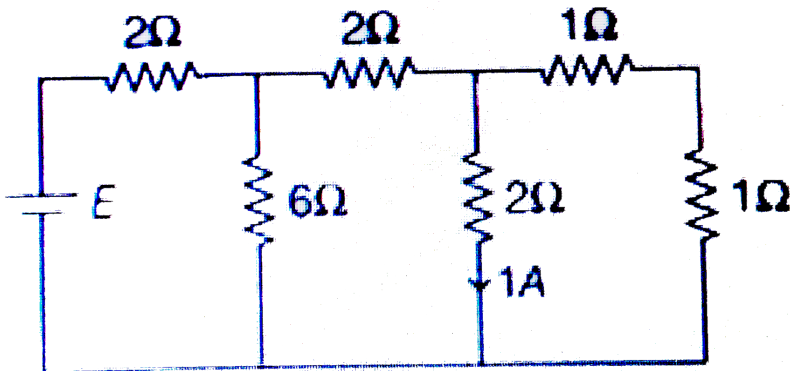

A. 12 V

B. 16 V

C. 18 V

D. 15 V

Answer: A



Watch Video Solution

56. A voltmeter with resistance 500Ω is used to measure the emf of a cell of internal resistance 4Ω . The percentage error in the reading of the voltmeter will be

A. 0.002

B. 0.008

C. 0.014

D. 0.022

Answer: B



Watch Video Solution

57. In the figure, the potentiometer wire of length $l = 100\text{cm}$ and resistance 9Ω is joined to a cell of emf $E_2 = 5V$ and internal resistance $r_2 = 2V$ is connected as shown. The

galvanometer is show no deflection when the length AC is

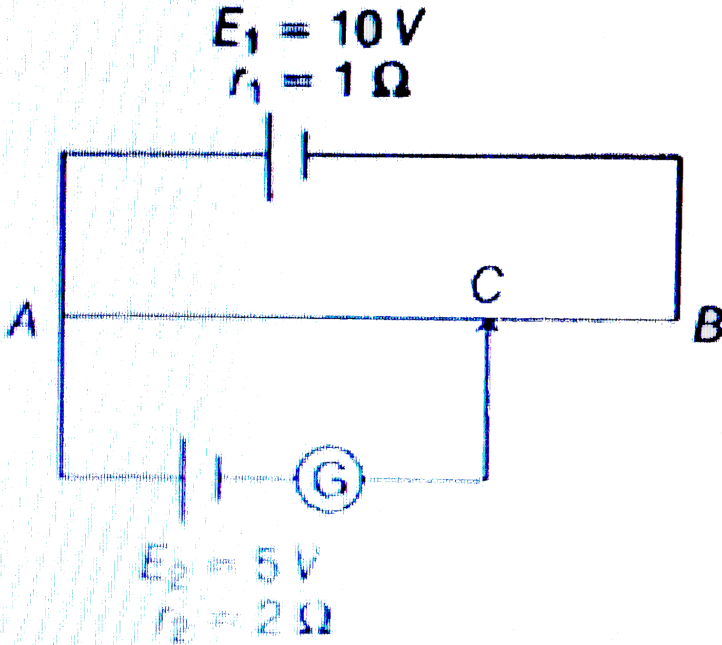

- A. 50 cm
- B. 55.55 cm
- C. 52.67 cm
- D. 54.33 cm

Answer: B



Watch Video Solution

58. The potential difference across the terminals of a battery is 10 V when there is a current of 3 A in the battery from the negative to the positive terminal. When the current is 2A in the reverse direction, the potential difference becomes 15 V. The internal resistance of the battery is

- A. 2.5Ω
- B. 5.0Ω
- C. 2.83Ω
- D. 1Ω

Answer: D



Watch Video Solution

59. In the circuit shown, if a wire is connected between points A and B. How much current will flow through that wire?

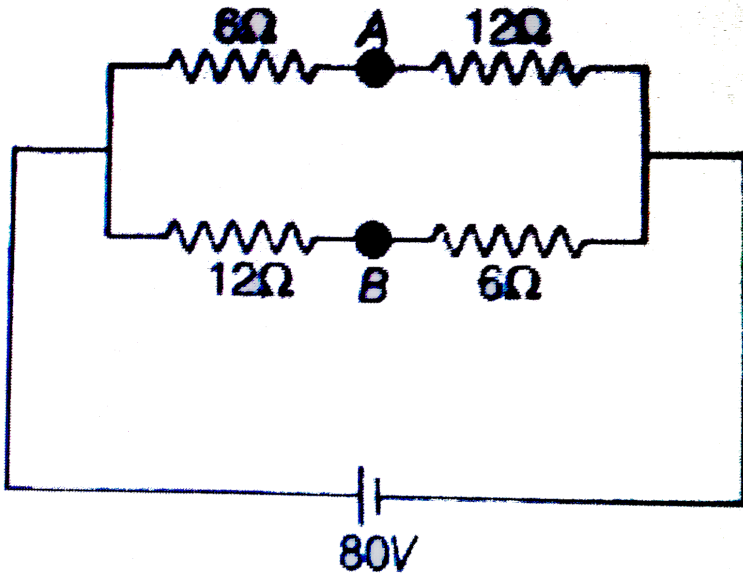

- A. 5A
- B. $\frac{10}{3} A$
- C. $\frac{20}{3} A$
- D. $\frac{5}{3} A$

Answer: B

60. Eight resistances each of resistance 5Ω are connected in the circuit as shown in figure. The equivalent resistance between A and B is

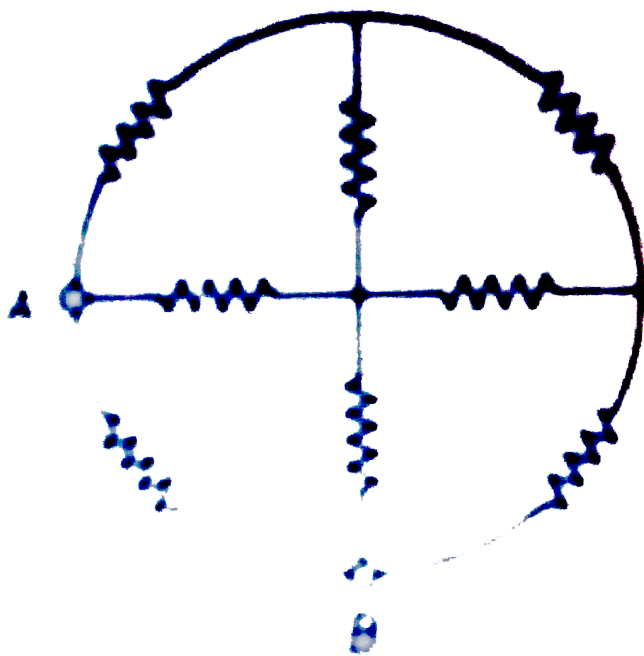

A. $\frac{8}{3}\Omega$

B. $\frac{16}{3}\Omega$

C. $\frac{15}{7} \Omega$

D. $\frac{19}{2} \Omega$

Answer: C



Watch Video Solution

61. Twelve resistors each of resistance 1Ω are connected in the circuit shown in figure. Net resistance between point A and H

would be

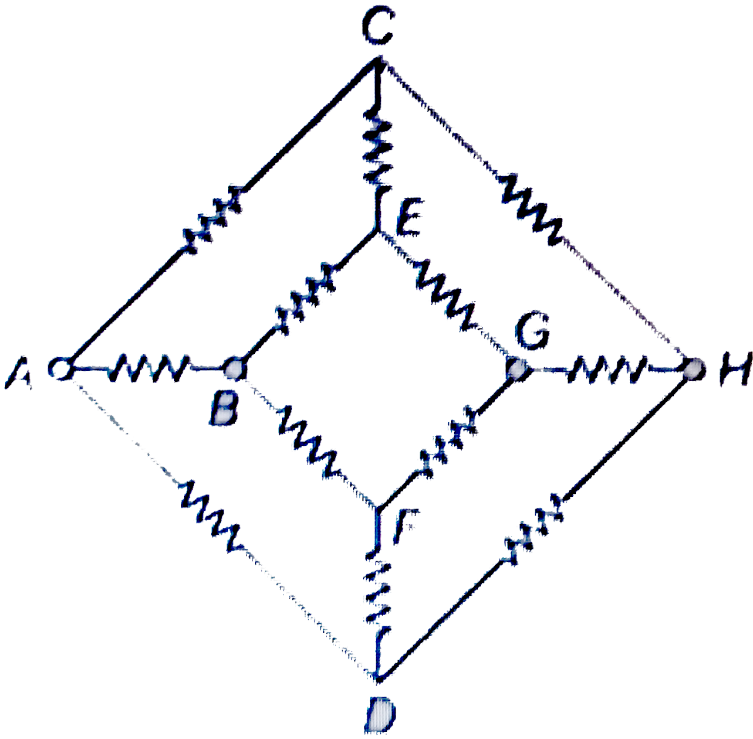

- A. $\frac{5}{3} \Omega$
- B. $\frac{16}{3} \Omega$
- C. $\frac{15}{7} \Omega$
- D. $\frac{19}{2} \Omega$

Answer: C



Watch Video Solution

62. n identical cells are joined in series with two cells A and B with reversed polarities. EMF of each cell is E and internal resistance is r . Potential difference across cell A or B is ($n > 4$)

A. $\frac{2E}{n}$

B. $2E\left(1 - \frac{1}{n}\right)$

C. $\frac{4E}{n}$

D. $2E\left(1 - \frac{2}{n}\right)$

Answer: D



Watch Video Solution

63. Find the resistor in which maximum heat will be produced.

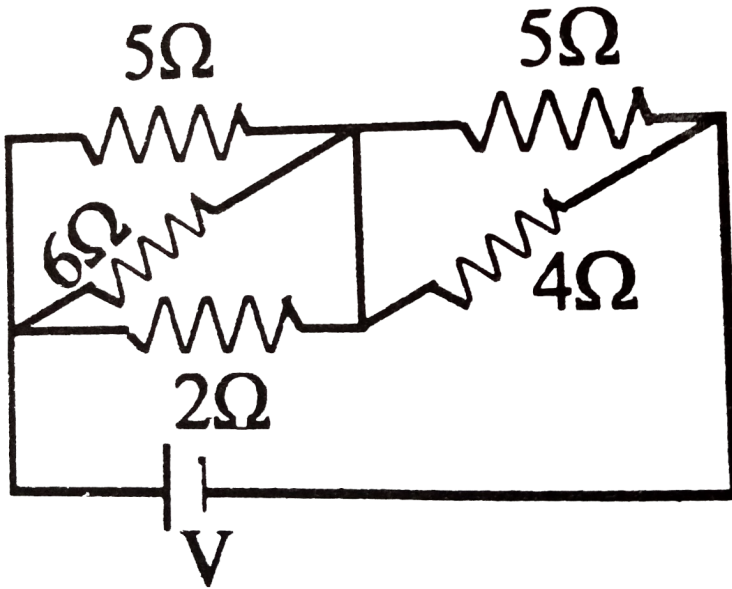

A. 6Ω

B. 2Ω

C. 5Ω

D. 4Ω

Answer: D

64. The potential difference between the points A and B in the circuit shown is 16 V, Which is/are the correct statement(s) out of the following?

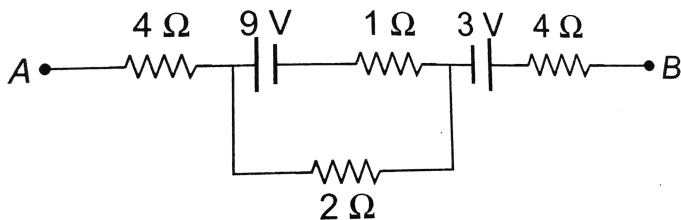

- A. 2.5 A
- B. 3.5 A
- C. 4.0 A
- D. zero

Answer: B

65. Under what condition, the current passing through the resistance R can be increased by short - circuiting the battery of emf E_2 The internal resistances of the two batteries are r_1 and r_2 , respectively.

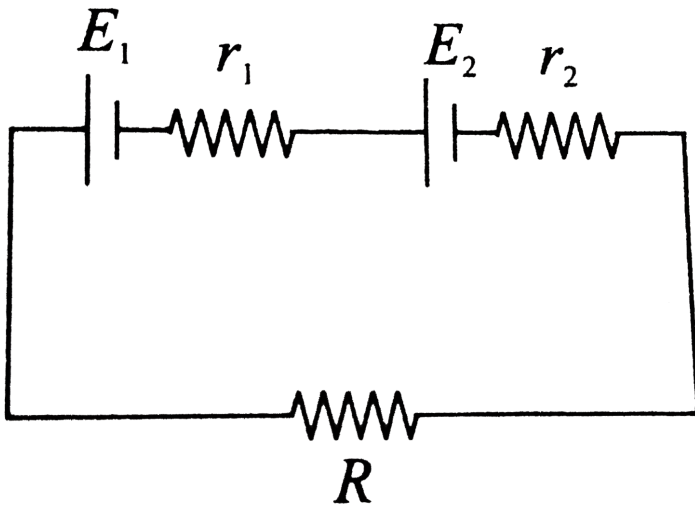

A. $E_2 r_1 > E_1 (R + r_2)$

B. $E_1 r_2 > E_2 (R + r_1)$

C. $E_2 r_2 > E_1 (R + r_2)$

D. $E_1 r_1 > E_2 (R + r_1)$

Answer: B

 [Watch Video Solution](#)

66. In the circuit shown in figure, reading of voltmeter is V_1 when only S_1 is closed, reading of voltmeter is V_2 when only S_2 is closed, and reading of voltmeter is V_3 when both S_1 and S_2 are

closed. Then .

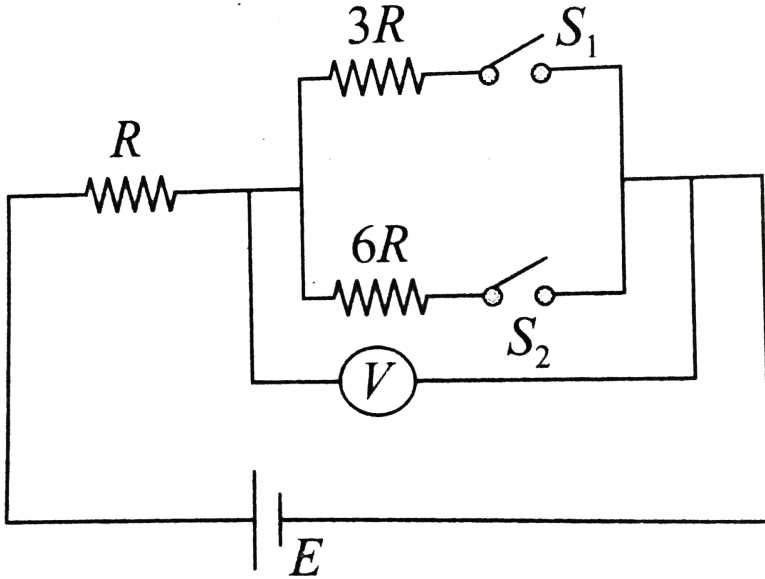

- A. $V_3 > V_2 > V_1$
- B. $V_2 > V_1 > V_3$
- C. $V_3 > V_1 > V_2$
- D. $V_1 > V_2 > V_3$

Answer: B

 [Watch Video Solution](#)

67. A resistance R carries a current i . The power lost to the surrounding is $\lambda(\theta - \theta_0)$. Here, λ is a constant, θ is temperature of the resistance and θ_0 is the temperature of the atmosphere. If the coefficient of linear expansion is α . The strain in the resistance is

A. $\frac{\alpha}{\lambda} l^2 R$

B. $\alpha\lambda / R$

C. $\frac{\alpha l^2 R}{2\lambda}$

D. proportional to the length of the resistance wire

Answer: A



Watch Video Solution

68. For what value of R in the circuit as shown, current passing through 4Ω resistance will be zero

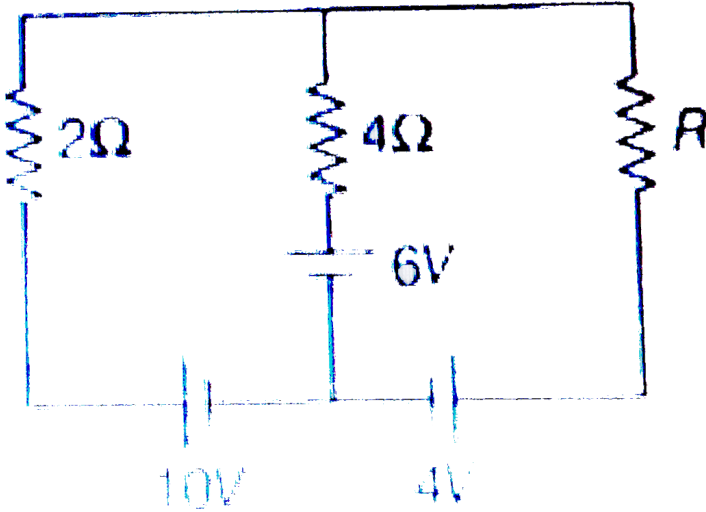

- A. 1Ω
- B. 2Ω
- C. 3Ω
- D. 4Ω

Answer: A

69. In the circuit shown, when switch S_1 is closed and S_2 is open, the ideal voltmeter shows a reading of $18V$. When switch S_2 is closed and S_1 is open, the reading of voltmeter is $24V$. When S_1 and S_2 both are closed, the voltmeter reading will be

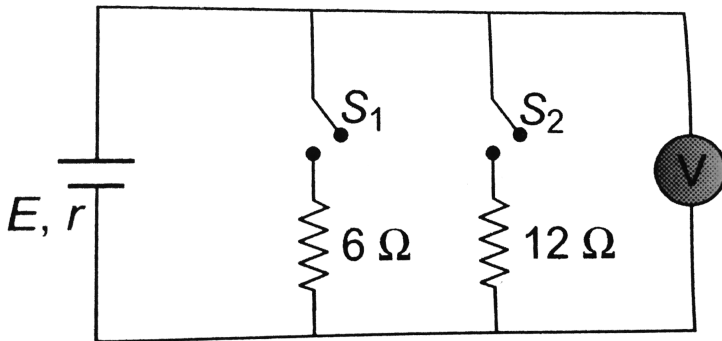

- A. $14.4\ V$
- B. $20.6\ V$
- C. $24.2\ V$
- D. $10.8\ V$

Answer: A

 Watch Video Solution

70. In the circuit shown in figure

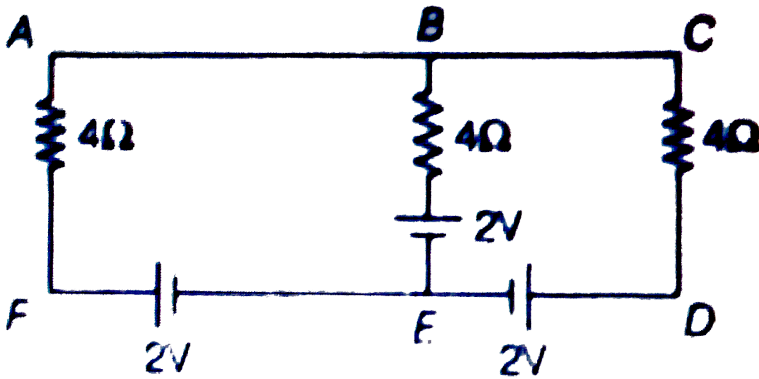

- A. current in wire AF is 1A
- B. current in wire CD is 1A
- C. current in wire BE is 2A
- D. None of these

Answer: D

 Watch Video Solution

71. The equivalent resistance across AB in the given network is

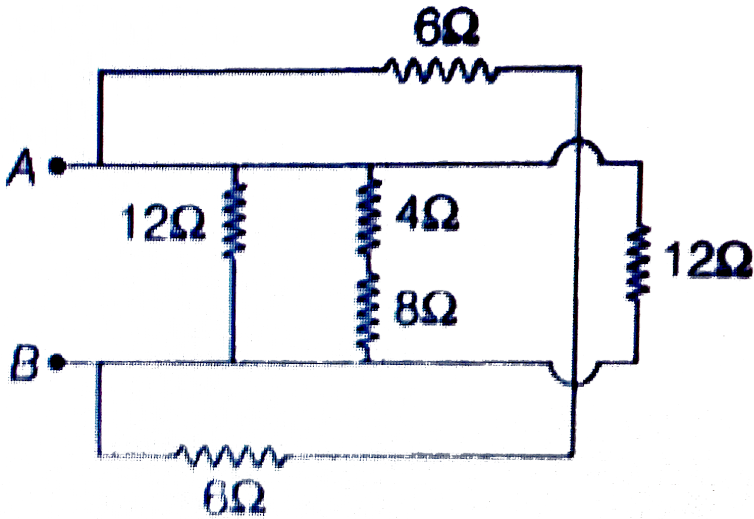

A. 4Ω

B. 3Ω

C. 12Ω

D. $\frac{4}{3}\Omega$

Answer: B

 [Watch Video Solution](#)

72. The n rows each containing m cells in series are joined in parallel. Maximum current is taken from this combination across an external resistance of 3Ω resistance. If the total number of cell used are 24 and internal resistance of each cell is 0.5Ω , then

A. $m = 8, n = 3$

B. $m = 6, n = 4$

C. $m = 12, n = 2$

D. $m = 2, n = 12$

Answer: C

 Watch Video Solution

73. The equivalent resistance between points A and B is

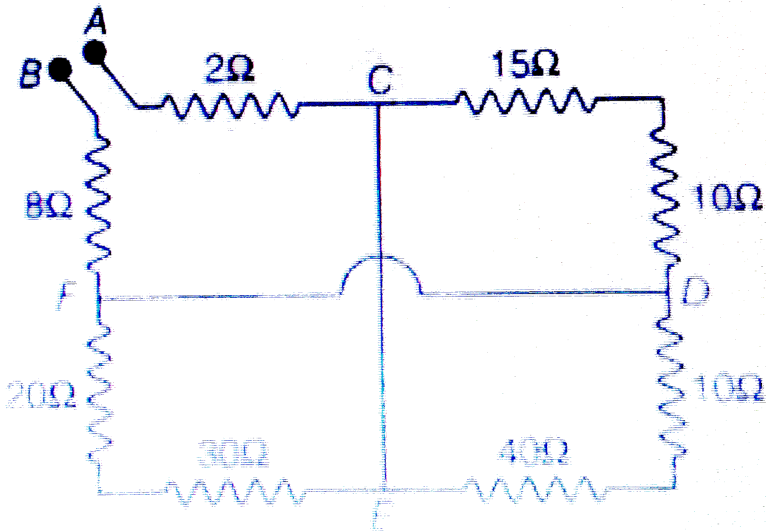

A. 32.5Ω

B. 22.5Ω

C. 12.5Ω

D. 42.5Ω

Answer: B

 Watch Video Solution

74. A battery of internal resistance 4Ω is connected to the network of resistances as shown in Fig. 7.40. In order that the maximum power can be delivered to the network, the value of R in Ω should be

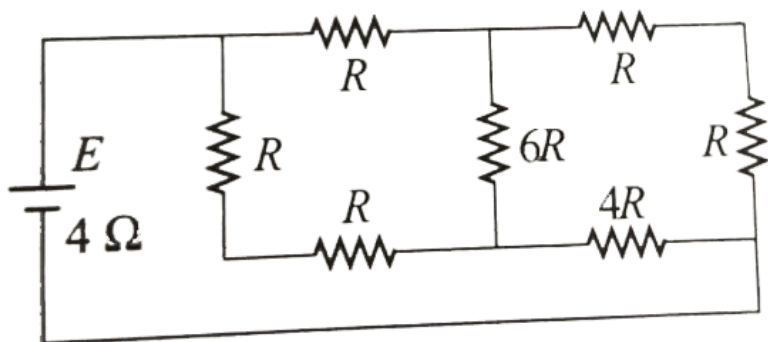

A. $\frac{4}{9}\Omega$

B. $\frac{8}{9} \Omega$

C. $\frac{39}{7} \Omega$

D. $\frac{11}{7} \Omega$

Answer: C

 Watch Video Solution

75. In the circuit shown in figure switch S can be shift to position A or position B. Current through resistance is say i_1 when switch is in position. A and when switch is in position B, then

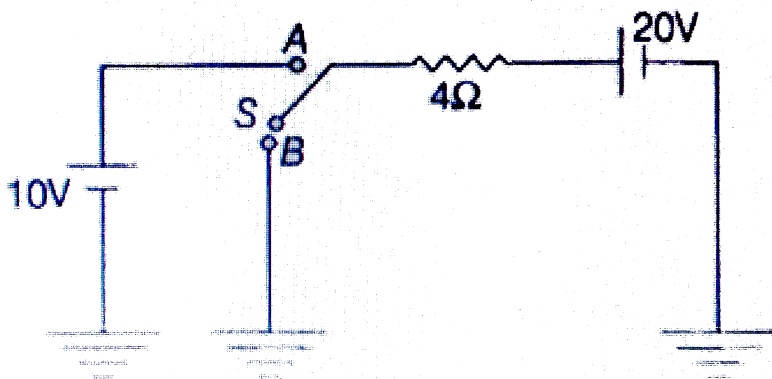

A. $i_1 = 2.5A$

B. $i_2 = 0$

C. both (a) and (b) are correct

D. both (a) and (b) wrong

Answer: A

 [Watch Video Solution](#)

76. A galvanometer has resistance G and full scale deflection current i . To convert this galvanometer into an ammeter of range $10 I$, a shunt $S = \frac{G}{9}$ is connected in parallel with G . Now we want to measure potential difference with the help of this ammeter. What is the maximum value of potential difference which can be measured with the help of this?

A. $10IG$

B. IG

C. $9IG$

D. $\frac{10}{9}IG$

Answer: B



Watch Video Solution

77. Four resistance are connected to a DC battery as shown in figure. Maximum power will be developed across Ohm

resistance.

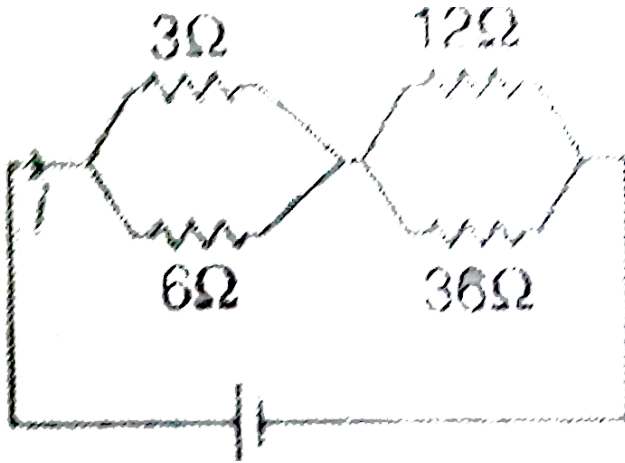

- A. 3
- B. 6
- C. 12
- D. 36

Answer: C

 [Watch Video Solution](#)

78. A hollow cylinder of specific resistance ρ , inner radius R , outer radius $2R$ and length l is as shown in figure. What is the net resistance between the inner and outer surfaces?

A. $\frac{3\pi R^2 \rho}{l}$

B. $\frac{\rho R}{2\pi}$

C. $\frac{\rho l \ln(2)}{2\pi l}$

D. $\frac{\rho \ln(2)}{l}$

Answer: C



[Watch Video Solution](#)

79. A group of identical cells (all in parallel) are connected to an external resistance R_1 . Current through R_1 is i_1 . Another group

of identical cells (all in series) are connected to some other resistance R_2 . Current through R_2 is i_2 . Now one cell is removed from both the groups. Then

A. i_1 will decrease

B. i_2 may decrease or increase depending on the value E and

r

C. both (a) and (b) are correct

D. both (a) and (b) wrong

Answer: A



[Watch Video Solution](#)

80. Five identical cells are connected in parallel. Now, polarity of one of the cells is reversed. Percentage change in equivalent emf

will be

A. -0.1

B. -0.2

C. -0.4

D. -0.6

Answer: C



Watch Video Solution

81. In the circuit shown in figure, current is zero through

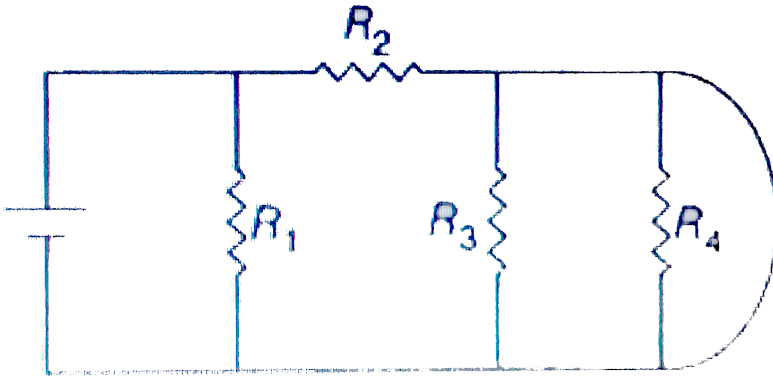

- A. R_4 only
- B. R_3 and R_4
- C. R_2 and R_4
- D. R_2 , R_3 and R_4

Answer: B

 [Watch Video Solution](#)

82. If internal resistance of a cell is proportional to current drawn from the cell. Then the best representation of terminal potential difference of a cell with current drawn from cell will be

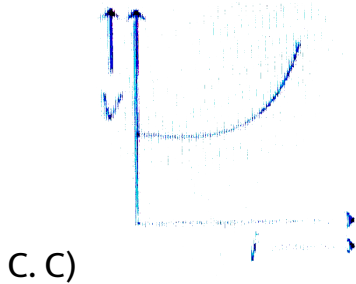
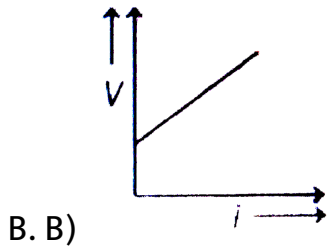
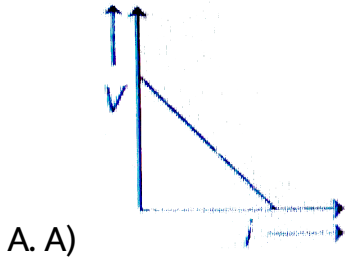

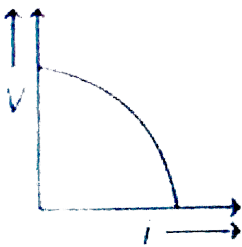

D. D)

Answer: D

[Watch Video Solution](#)

83. A galvanometer, together with an unknown resistance in series, is connected across two identical batteries of each $1.5V$. When the batteries are connected in series, the galvanometer records a current of $1A$, and when the batteries are connected in parallel, the current is $0.6A$. In this case, the internal resistance of the battery is

A. $r = \frac{2}{3}\Omega$

B. $r = \frac{2}{5}\Omega$

C. $r = \frac{1}{3}\Omega$

D. $r = \frac{3}{2}\Omega$

Answer: C

 Watch Video Solution

84. In the figure shown, the thermal power generated in 'Y' is maximum when $Y = 4\Omega$. Then X is

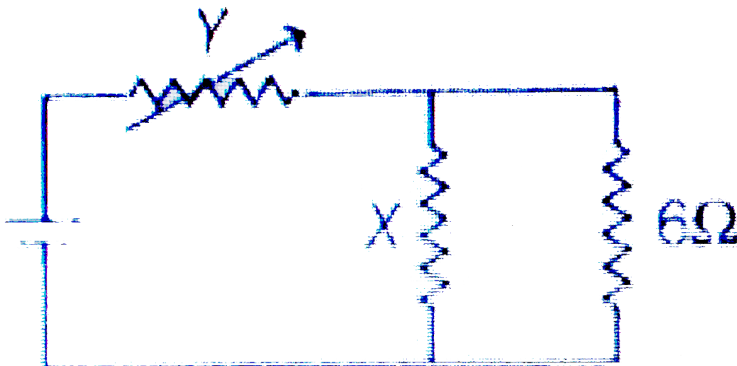

A. A) 2Ω

B. B) 3Ω

C. C) 2Ω

D. D) 6Ω

Answer: B



Watch Video Solution

85. A cell of emf E having an internal resistance R varies with R as shown in figure by the curve

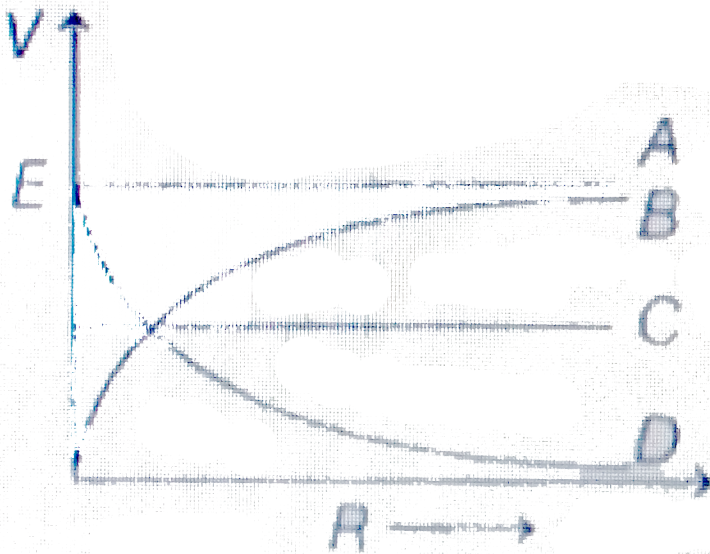

A. A) A

B. B) B

C. C) C

D. D) D

Answer: D

 [Watch Video Solution](#)

86. Six wires each of resistance r form a tetrahedron. The equivalent resistance between corners 1-2 and 1-3 are respectively

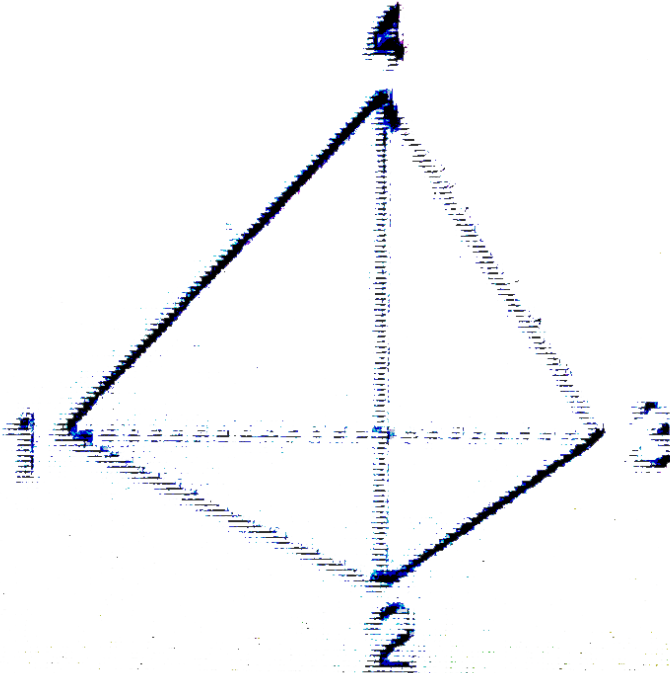

A. $\frac{r}{2}, \frac{r}{2}$

B. r, r

C. $\frac{r}{2}, r$

D. $r, \frac{r}{2}$

Answer: A

 [Watch Video Solution](#)

87. A series parallel combination battery consisting of a large number $N = 300$ of identical cells, each with an internal resistance $r = 0.3\Omega$, is loaded with an external resistance $R = 10\Omega$. Find the number n of parallel groups consisting of an equal number of cells connected in series, at which the external resistance generates the highest thermal power.

A. A) 2

B. B) 3

C. C) 4

D. D) 6

Answer: B



Watch Video Solution

88. One end of a Nichrome wire of length $2L$ and cross-sectional area A is attached to an end of another Nichrome wire of length L and cross-sectional area $2A$. If the free end of the longer wire is at an electric potential of 8.0 volts, and the free end of the shorter wire is at an electric potential 1.0 volts, the potential at the junction of the two wires is equal to

A. 2.4 V

B. 3.2 V

C. 4.5 V

D. 5.6 V

Answer: A

 Watch Video Solution

89. In the circuit shown, the resistance are given ohms and the battery is assumed ideal with end equal to 3.0 volts. The resistance that dissipates the maximum power is

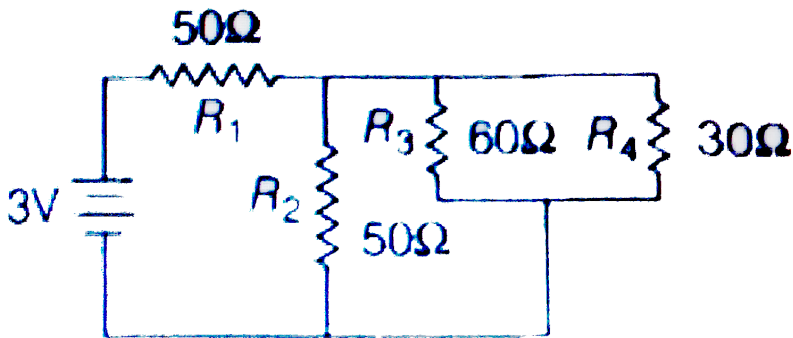

A. R_1

B. R_2

C. R_3

D. R_4

Answer: A



Watch Video Solution

90. In the diagram, resistance between any two junction is R .
Equivalent resistance across terminals A and B is (assume P and Q

also as junction)

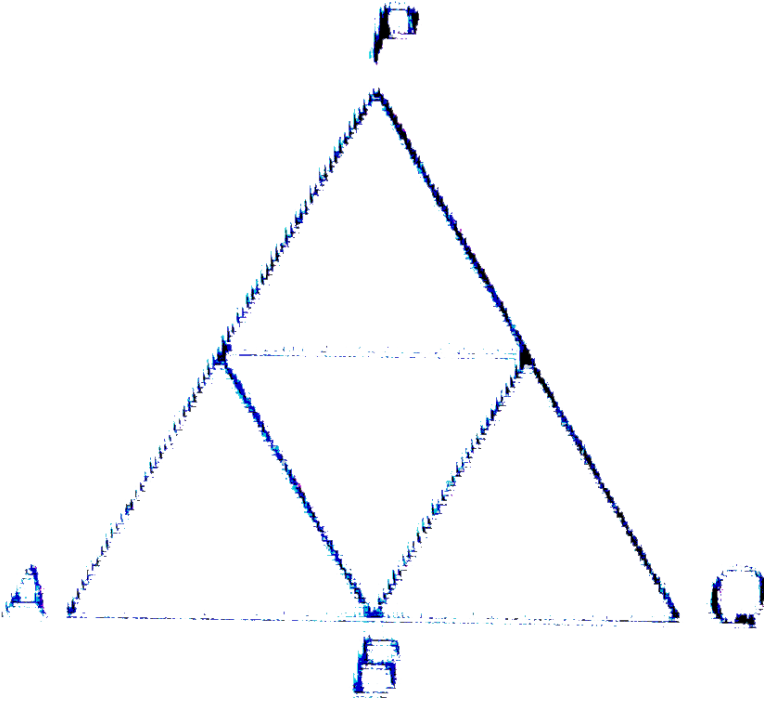

A. A) $\frac{11R}{7}$

B. B) $\frac{18R}{11}$

C. C) $\frac{7R}{11}$

D. D) $\frac{11R}{18}$

Answer: D



Watch Video Solution

91. A battery of emf $E_0 = 12V$ is connected across a $4m$ long uniform wire having resistance $\frac{4\Omega}{m}$. The cells of small emfs $\varepsilon_1 = 2V$ and $\varepsilon_2 = 4V$ having internal resistance 2Ω and 6Ω respectively, are connected as shown in the figure. If galvanometer shows no deflection at the point N , the distance

of point N from the point A is equal to

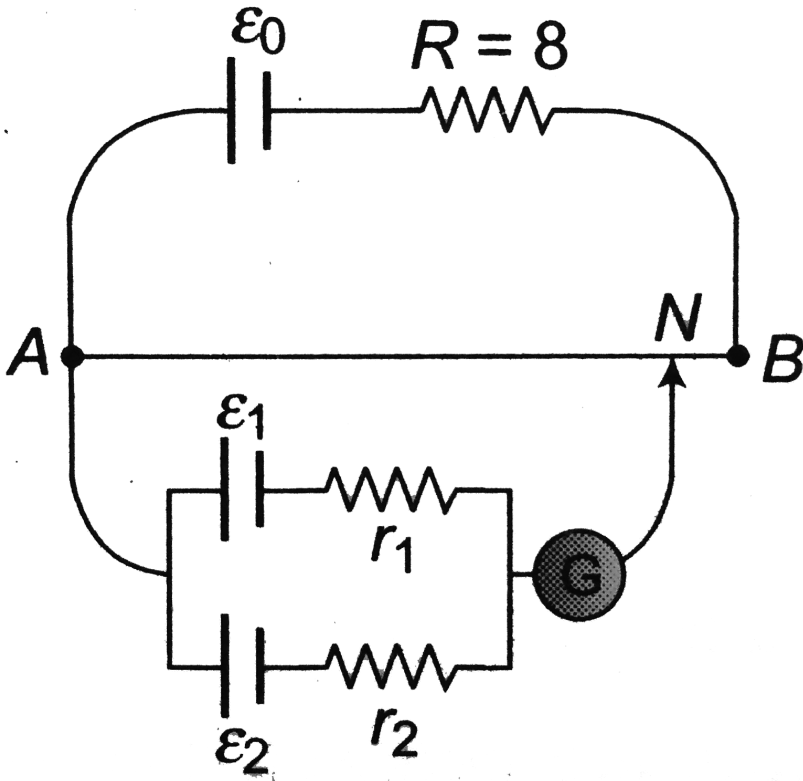

- A. 2.5 m
- B. 3 m
- C. 1.25 m
- D. 0.75 m

Answer: C

92. In the circuit shown, what is the potential difference V_{PQ} ?

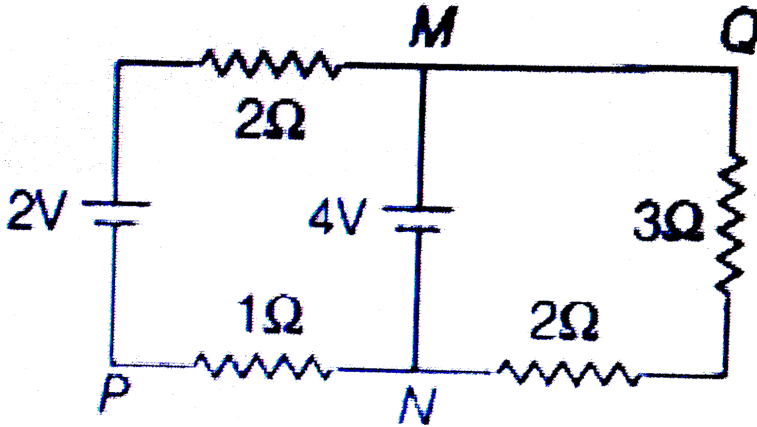

- A. +3V
- B. +2V
- C. -2V
- D. None of these

Answer: B

93. In an experiment, a graph was plotted of the potential difference V between the terminals of a cell against the circuit current " i " by varying load rheostat, internal conductance of the cell is given by

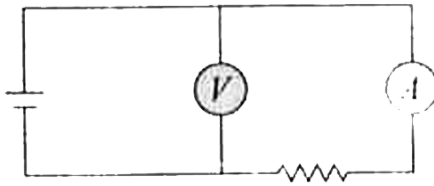
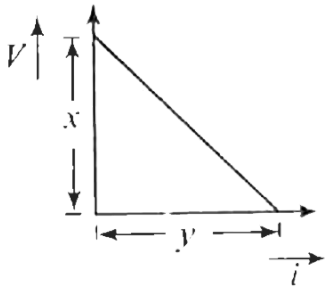

- A. X
- B. Y
- C. X/Y
- D. Y/X

Answer: D

[▶ Watch Video Solution](#)

94. In the circuit, 8 resistors of 2Ω and 8 resistors of 4Ω are connected as shown in the figure. The current in the branch AB is

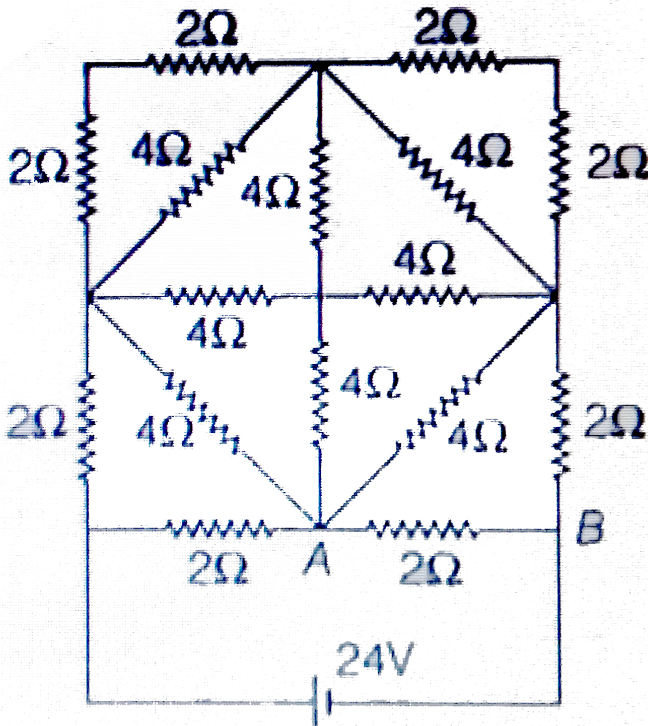

A. A) $4A$

B. B) $10A$

C. C) $6A$

D. D) $3A$

Answer: C



Watch Video Solution

95. A battery of emf E and internal resistance r is connected across a resistance R . Resistance R can be adjusted to any value greater than or equal to zero. A graph is plotted between the current passing through the resistance (I) and potential difference across the terminals of the battery (V). Maximum

power developed across the resistance R is

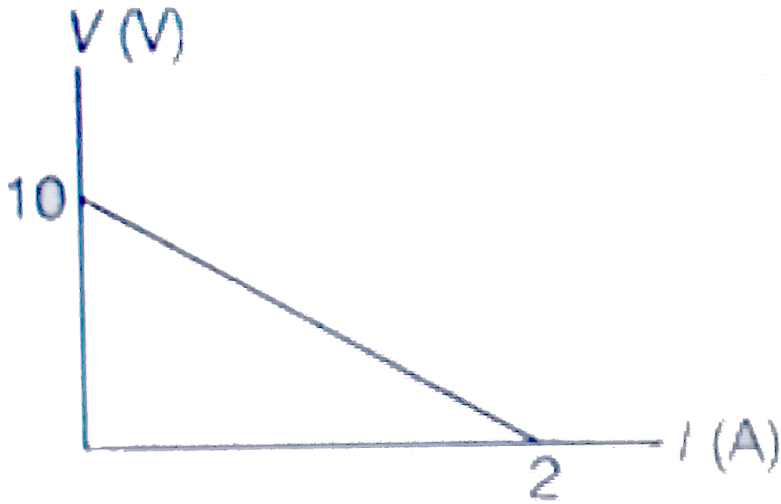

- A. 5 W
- B. 10 W
- C. 15 W
- D. 25 W

Answer: A

 [Watch Video Solution](#)

96. In the circuit shown in figure, the ratio

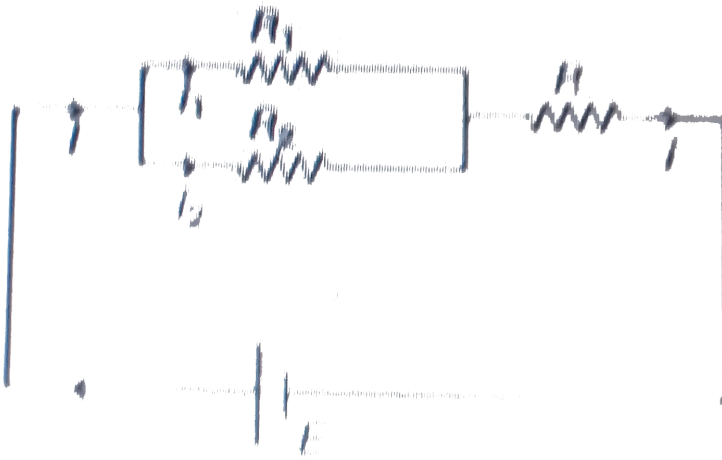

- A. i_1 / i_2 depends on R_1 and R_2 only
- B. i / i_1 depends on R_1 and R_2 only
- C. i / i_1 depends on E , R_1 , R_2 and R
- D. i_1 / i_2 depends on E , R_1 and R_2

Answer: A:B

 [Watch Video Solution](#)

97. In the circuit shown in figure

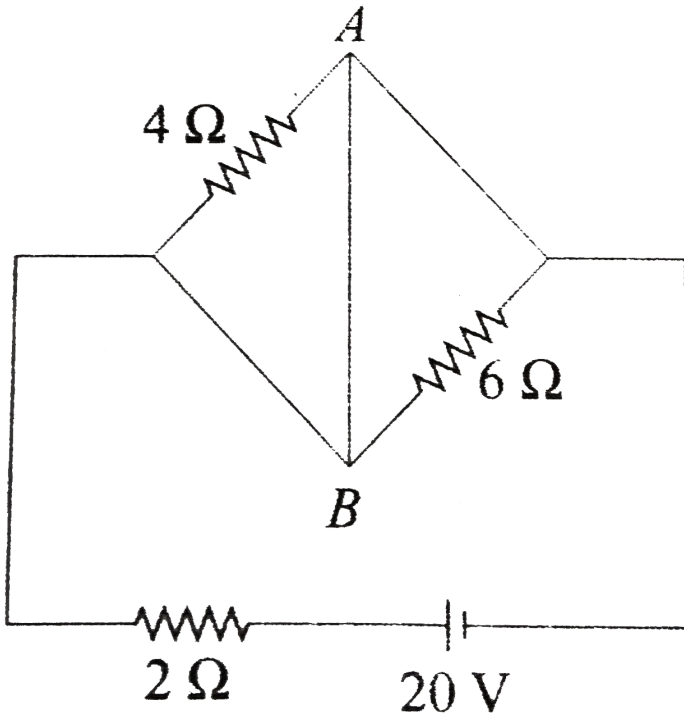

- A. A) power supplied by the battery is 200 W
- B. B) current flowing in the circuit is 5 A
- C. C) potential difference across 4Ω resistance is equal to the potential difference across 6Ω resistance
- D. D) current in wire AB is zero

Answer: A::C

 [Watch Video Solution](#)

98. A microammeter has as resistance of 100Ω and full scale range of $50\mu A$. It can be used as voltmeter or as a higher range ammeter provided a resistance is added to it. Pick the correct range and resistance combinations

- A. 50V range with $10k\Omega$ resistance in series
- B. 10V range with $200k\Omega$ resistance in series
- C. 5 mA range with 1Ω resistance in parallel
- D. 10 mA range with 1Ω resistance in parallel

Answer: B::C

 [Watch Video Solution](#)

99. In the circuit shown in figure

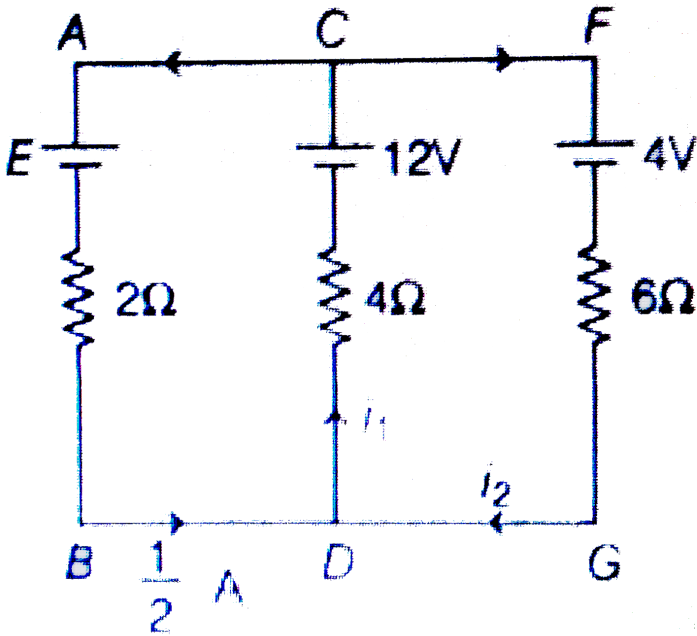

A. $E = 6.6 V$

B. $i_1 = 1.1 A$

C. $i_2 = 0.5 A$

D. $E = 4.4 V$

Answer: A::B

 [Watch Video Solution](#)

100. A voltmeter reads the potential difference across the terminals of an old battery as $1.40V$, while a potentiometer reads its voltage to be $1.55V$. The voltmeter resistance is 280Ω .

- A. the emf of the battery is $1.4 V$
- B. the emf of the battery is $1.55 V$
- C. the internal resistance r of the battery is 30Ω
- D. the internal resistance r of the battery is 5Ω

Answer: B::C

 [Watch Video Solution](#)

101. A battery of emf E and internal resistance r is connected across a resistance R . Resistance R can be adjusted to any value greater than or equal to zero. A graph is plotted between the current passing through the resistance (I) and potential difference across the terminals of the battery (V). Maximum power developed across the resistance R is

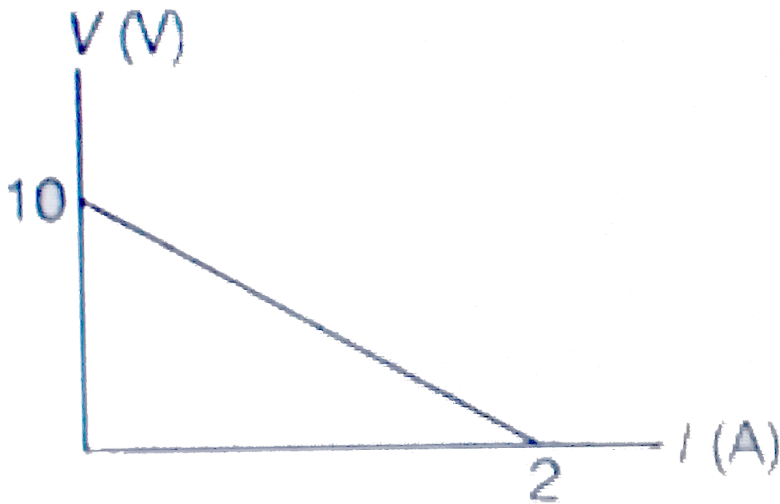

A. Internal resistance of the battery is 5Ω

B. EMF of the battery is 10V

C. Maximum current which can be taken from the battery is 2A

D. EMF of the battery is 5V

Answer: A::B::C

[Watch Video Solution](#)

102. In the circuit shown in figure

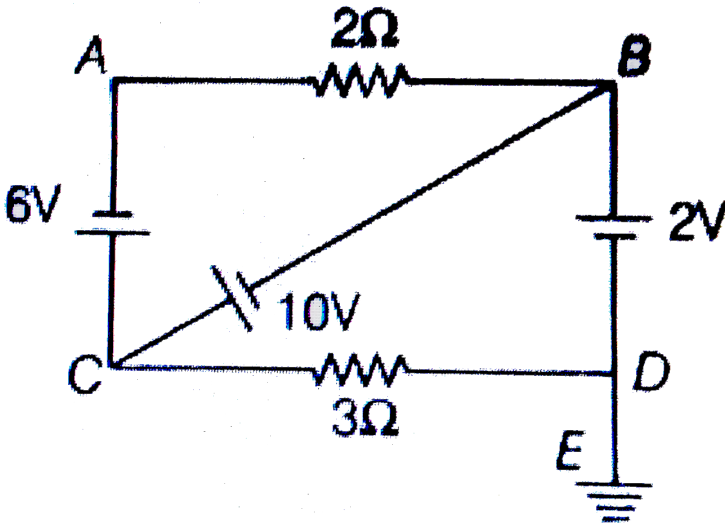

A. A) current passing through 2Ω resistance is 2 A

B. B) current passing through 3Ω resistance is 4 A

C. C) current in wire DE is zero.

D. D) potential of point A is 10 V

Answer: A::B::C

 [Watch Video Solution](#)

103. Two bulbs consume same power when operated at 200 V and 300 V, respectively. When these bulbs are connected in series across a DC source of 500 V, then

A. ratio of potential difference across them is $3/2$

B. ratio of potential difference across them is $4/9$

C. ratio of power consumed across them is $4/9$

D. ratio of power consumed across them is $2/3$

Answer: B::C

 [Watch Video Solution](#)

104. Potential difference across the terminal of a non ideal battery is

- A. zero when it is short circuited
- B. less than its emf when current flows from negative terminal to positive terminal inside the battery
- C. zero when no current is drawn from the battery
- D. greater than its emf when current flows from positive terminal to negative terminal inside the battery

Answer: A::B::D

 Watch Video Solution

105. Both terminals of a battery of emf E and internal resistance r are grounded as shown. Select the correct alternative(s).

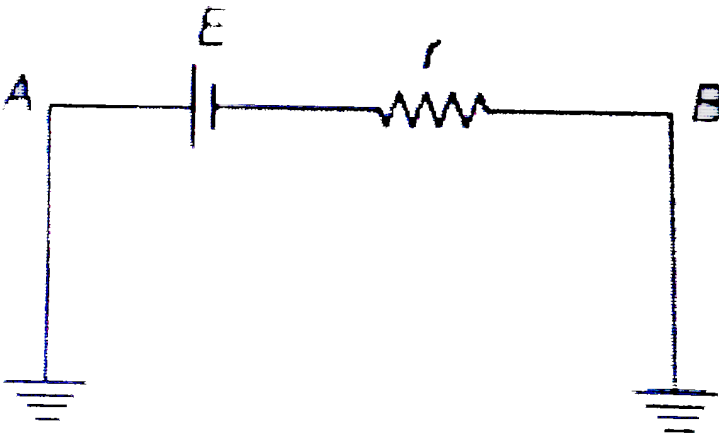

- A. Potential difference across A and B is zero
- B. Potential difference across A and B is E
- C. Current across AB is zero

D. Current across AB is $\frac{E}{r}$

Answer: A::D

 Watch Video Solution

106. In the circuit shown in figure

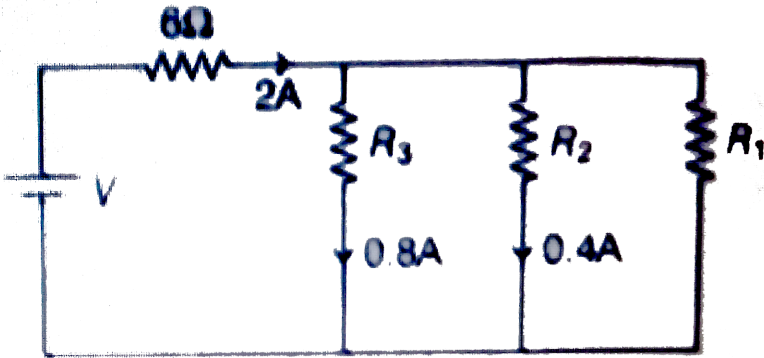

A. $V = 10V$

B. $R_1 = 10\Omega$

C. $R_2 = 20\Omega$

D. net resistance of the circuit is 10Ω

Answer: B::C::D

[Watch Video Solution](#)

107. In the circuit shown in figure potential difference across

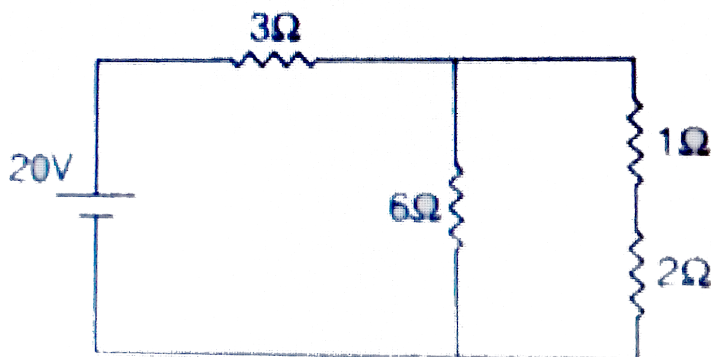

[Watch Video Solution](#)

108. The resistance of an ideal ammeter is

A. A) voltmeter should be zero

B. B) voltmeter should be infinite

C. C) ammeter should be zero

D. D) ammeter should be infinite

Answer: B::C

 **Watch Video Solution**

109. In the circuit shown in figure resistance of each wire is r . Net resistance across

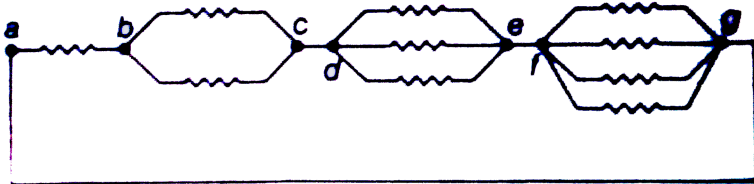

A. A) a and b is $\frac{13}{25}r$

B. B) b and c is $\frac{19}{50}r$

C. C) d and e is $\frac{7}{25}r$

D. D) f and g is $\frac{11}{50}r$

Answer: A::B::C::D

[▶ Watch Video Solution](#)

110. In the circuit shown in figure, power generated in

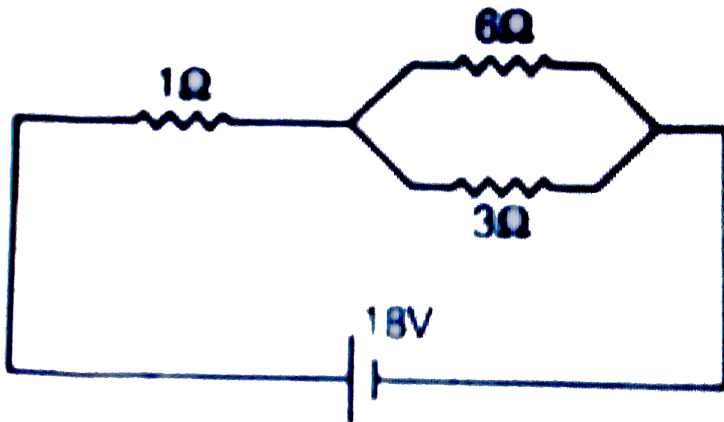

A. 1Ω resistance is maximum

B. 3Ω resistance is maximum

C. 1Ω resistance is minimum

D. 6Ω resistance is minimum

Answer: B::D

 Watch Video Solution

111. In the circuit shown in figure

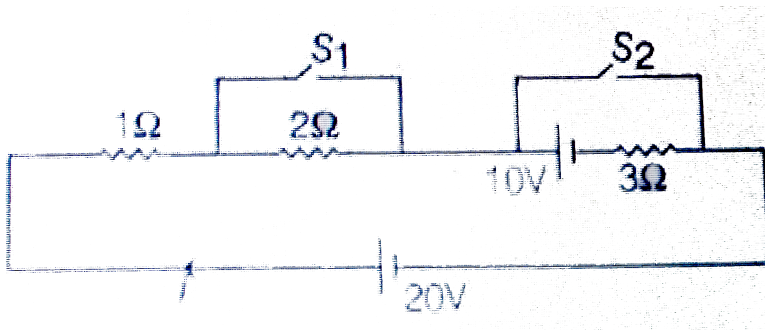

A. A) $I = 2.5A$ when S_1 is closed and S_2 is open

B. B) $I = \frac{20}{3}A$ when S_1 is open and S_2 is closed

C. C) $I = \frac{5}{3} A$ when S_1 and both are open

D. D) $I = 20 A$ when both S_1 and S_2 are closed

Answer: A::B::C::D

 Watch Video Solution

112. Figure shows part of a circuit. Which points have the same potential as that of point a

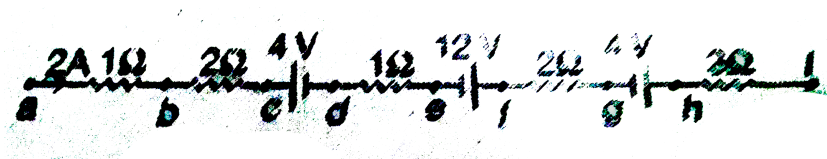

A. A) d

B. B) f

C. C) h

D. D) i

Answer: B::C



Watch Video Solution

113. A galvanometer has resistance 1Ω . Maximum deflection current through it is 0.1 A

A. A) To measure a current of 1A a resistance of $\frac{1}{10}\Omega$ is put in parallel with galvanometer

B. B) To measure a current of 1A a resistance of $\frac{1}{9}\Omega$ is put in parallel with galvanometer

C. C) To measure a potential difference of 10 V a resistance of 99Ω is put in series with galvanometer

D. D) To measure a potential difference of 10 V a resistance of 100Ω is put in series with galvanometer

Answer: B::C

 [Watch Video Solution](#)

114. In a potentiometer wire experiment the emf of a battery in the primary circuit is $20V$ and its internal resistance is 5Ω . There is a resistance box in series with the battery and the potentiometer wire, whose resistance can be varied from 120Ω to 170Ω . Resistance of the potentiometer wire is 75Ω . The following potential differences can be measured using this potentiometer.

A. A) $5V$

B. B) 6V

C. C) 7V

D. D) 8V

Answer: A::B::C



Watch Video Solution

115. In the network shown in fig. , points A, B, and C are at potentials of 70 V, 0, and 10V, respectively.

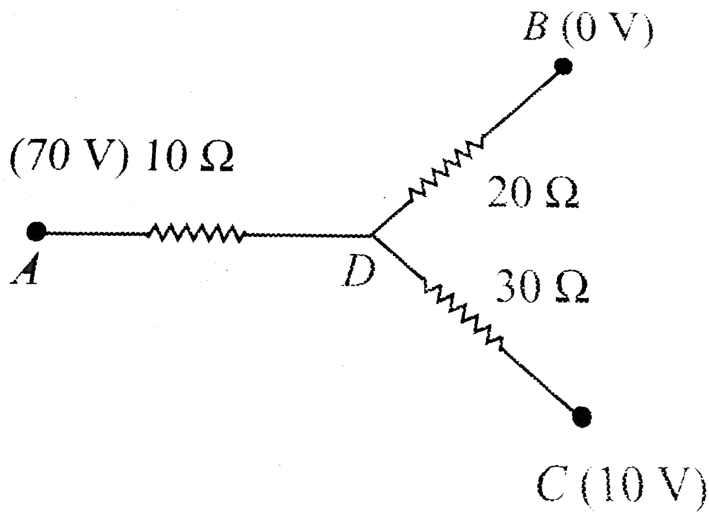

- A. Point D is at a potential of 40 V
- B. The currents in the sections AD , DB and DC are in the ratio $3:2:1$
- C. The current in the sections AD , DB and DC are in the ratio $1:2:3$
- D. The network draws a total power of 200 W

Answer: A::B::D



116. The value of the resistance R in figure is adjusted such that power dissipated in the 2Ω resistor is maximum. Under this condition

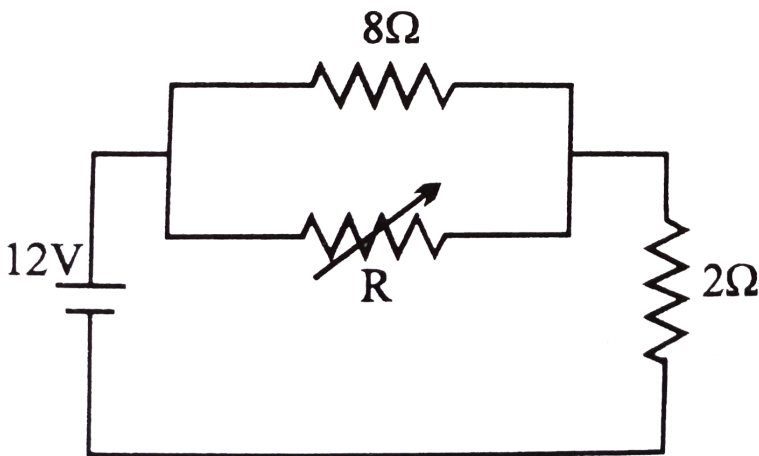

- A. $R = 0$
- B. $R = 8\Omega$
- C. power dissipated in the 2Ω resistors is 72 W
- D. power dissipated in the 2Ω resistors is 8 W

Answer: A::C

 Watch Video Solution

117. In the circuit shown E, F, G and H are cells of emf $2V, 1V, 3V$ and $1V$ respectively and their internal resistance are $2\Omega, 1\Omega, 3\Omega$ and 1Ω respectively.

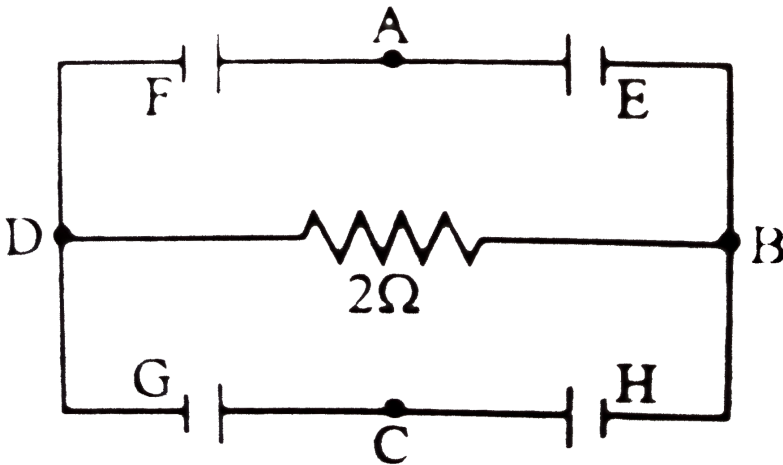

A. $V_D - V_B = -\frac{2}{13}V$

B. $V_D - V_B = \frac{2}{13}V$

C. $V_G = \frac{21}{13}V =$ potential difference across G

D. $V_H = \frac{19}{13}V =$ potential difference across H

Answer: B::C::D

 [Watch Video Solution](#)

118. A 20 m long potentiometer wire has a resistance of 20 Ohm. It is connected in series with a battery of emf 3V and resistance of 10Ω . The internal resistance of cell is negligible. If the length can be read accurately up to 1 mm, the potentiometer can read voltage:

- A. A) up to maximum of 0.2 mV
- B. B) with an accuracy of 0.2 mV
- C. C) with an accuracy of 0.1 mV

D. D) upto maximum of 2V

Answer: C::D

 Watch Video Solution

119. In the circuit shown, both cells are ideal and of fixed emf, the resistance of resistance R_1 has fixed resistance and the resistance of resistor R_2 can be varied (but the value of R_2 is not zero). Then:

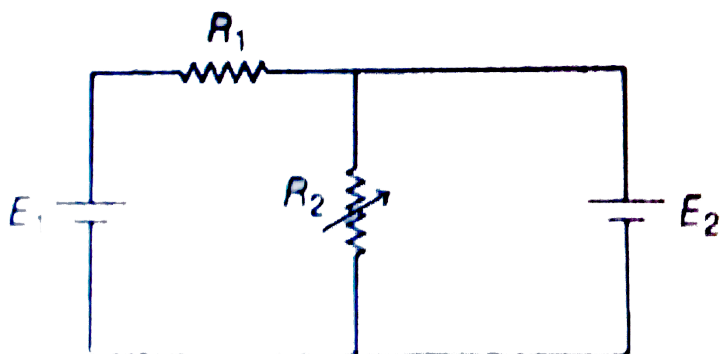

- A. A) The electric power delivered to resistor of resistance R_1 is independent of R_2
- B. B) Electric power delivered by E_1 is independent of R_2
- C. C) Electric power delivered by E_1 is dependent on R_2
- D. D) Electric power delivered to R_1 is dependent on R_2

Answer: A::B

 [Watch Video Solution](#)

120. Two identical voltmeters and two identical ammeter are connected to a battery of negligible resistance shown in the figure. The readings of devices are follows

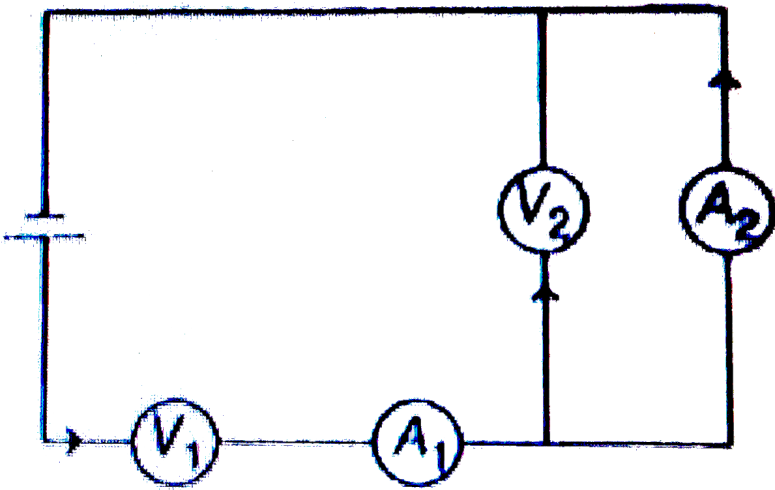

Reading of Ammeter $A_1 = 200\mu A$

Reading of voltmeter $V_2 = 2$ volt

Reading of voltmeter $V_1 = 100$ volt

Choose the correct option(s)

- A. Reading of ammeter A_2 is $196\mu A$
- B. Resistance of voltmeter is $0.5M\Omega$
- C. Resistance of ammeter is $10.2k\Omega$
- D. Current passing through voltmeter V_2 is $4\mu A$

Answer: A::B::C::D

 Watch Video Solution

121. In the circuit shown, total power supplied by an ideal battery is 80 W. if $R = 10\Omega$. Then EMF of the battery is

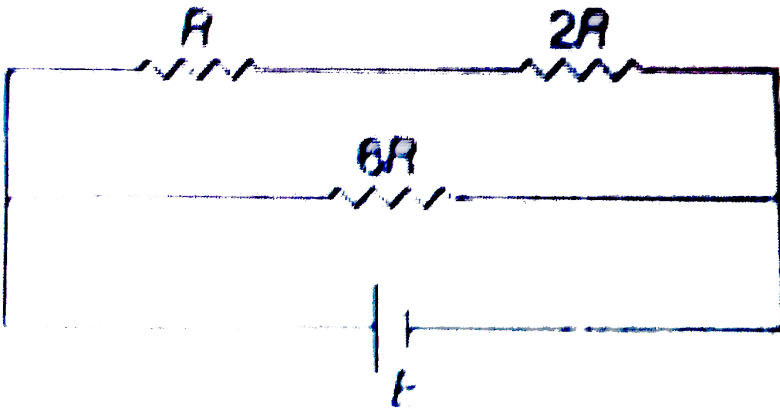

A. 20 V

B. 10 V

C. 40 V

D. 60 V

Answer: C

 Watch Video Solution

122. In the circuit shown, total power supplied by an ideal battery is 80 W. if $R = 10\Omega$. Then Ratio of power developed across R , $2R$ and $6R$ will be

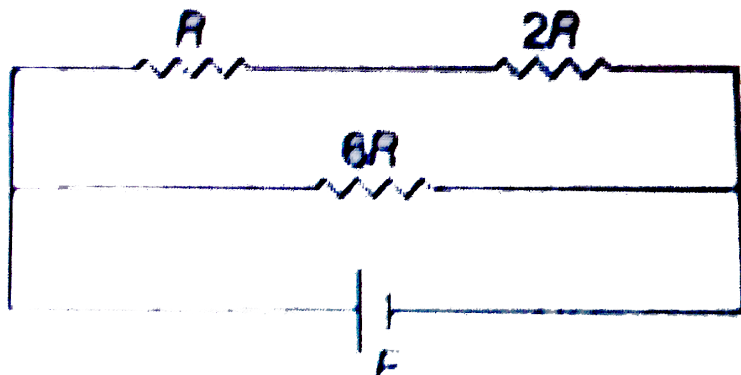

A. 2 : 4 : 3

B. 1 : 2 : 6

C. 2: 4: 6

D. 1: 2: 3

Answer: A

 [Watch Video Solution](#)

123. In the circuit shown, total power supplied by an ideal battery is 80 W. if $R = 10\Omega$. If the resistance R is removed from the circuit. Then

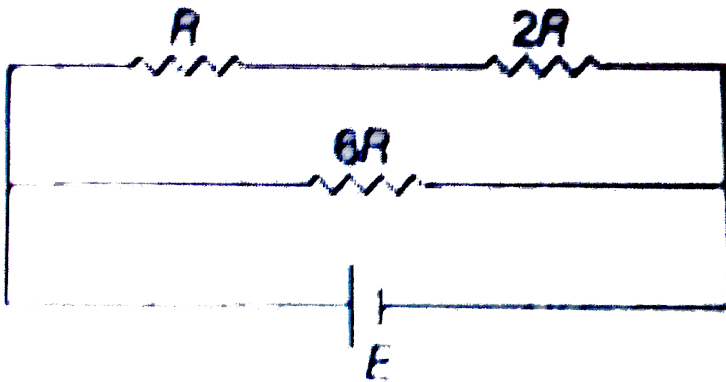

- A. power consumed by $2R$ will increase
- B. power consumed by $6R$ will increase
- C. both (a) and (b) are correct
- D. both (a) and (b) wrong

Answer: A



Watch Video Solution

124. In the circuit shown in figure

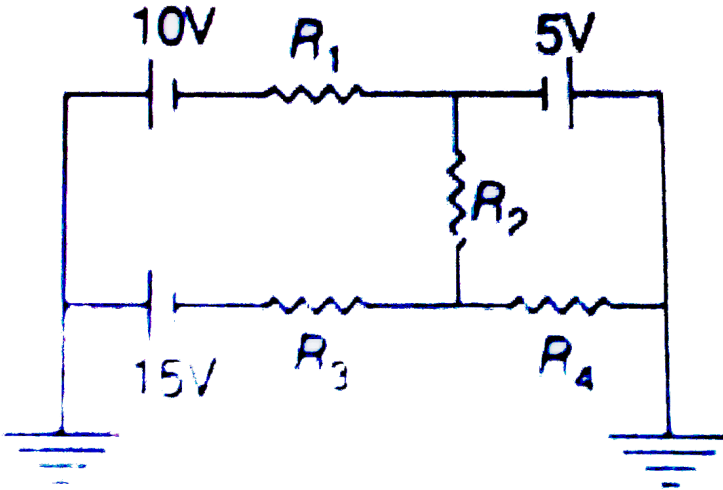

Current through R_2 is zero if $R_4 = 2\Omega$ and $R_3 = 4\Omega$ In this case

- A. Current through R_3 is 2A
- B. Current through R_4 is 3A
- C. both (a) and (b) are correct
- D. both (a) and (b) wrong

Answer: D

 Watch Video Solution

125. In the circuit shown in figure

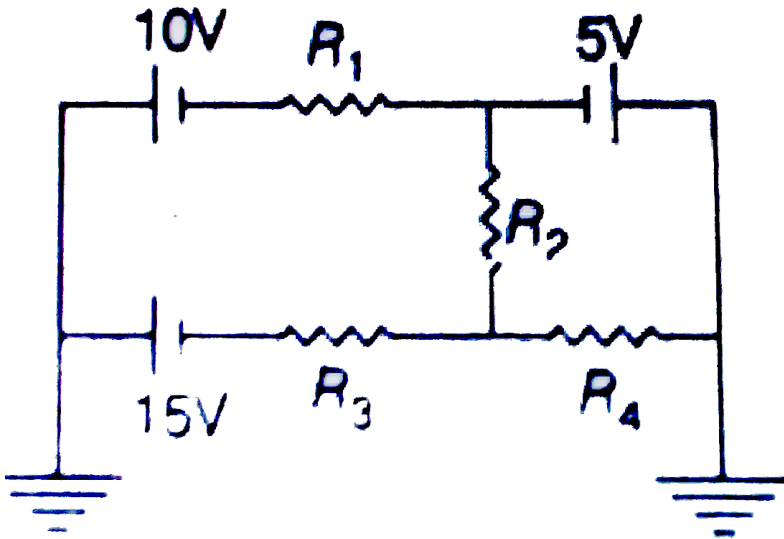

Current through R_1 is independent of

A. R_2

B. R_3

C. R_4

D. All of these

Answer: D

 Watch Video Solution

126. In the circuit shown in figure

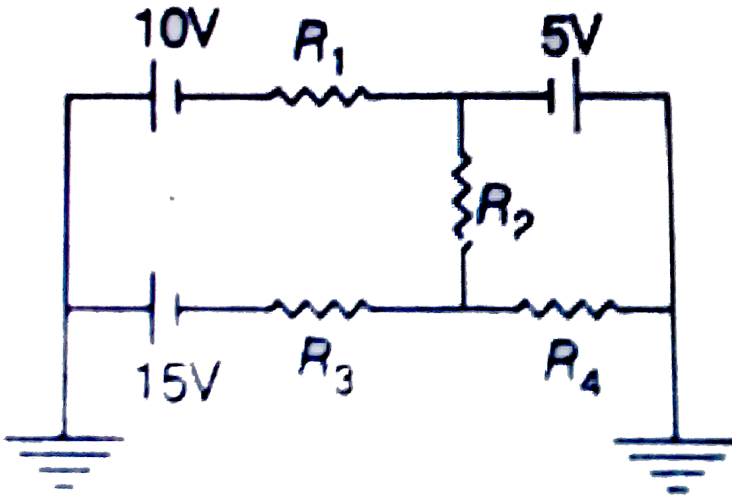

For what ratio $\frac{R_2}{R_4}$, current through R_3 will be zero

A. 1:1

B. 1:2

C. 1:3

D. Not possible

Answer: D



Watch Video Solution

127. For the circuit shown figure answer the following questions

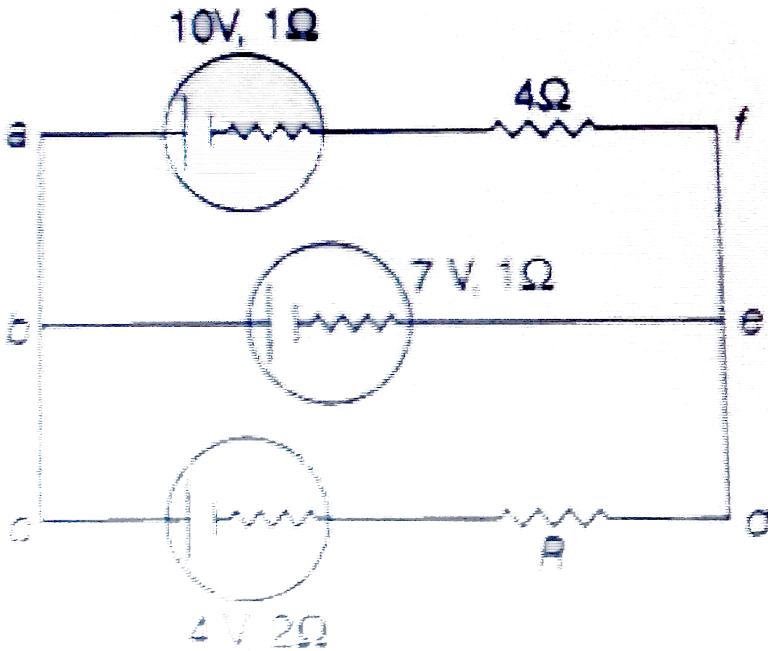

For what value of R, current through 7V battery is zero?

- A. A) 3Ω
- B. B) 4Ω
- C. C) 5Ω
- D. D) 6Ω

Answer: A

 Watch Video Solution

128. For the circuit shown figure answer the following questions

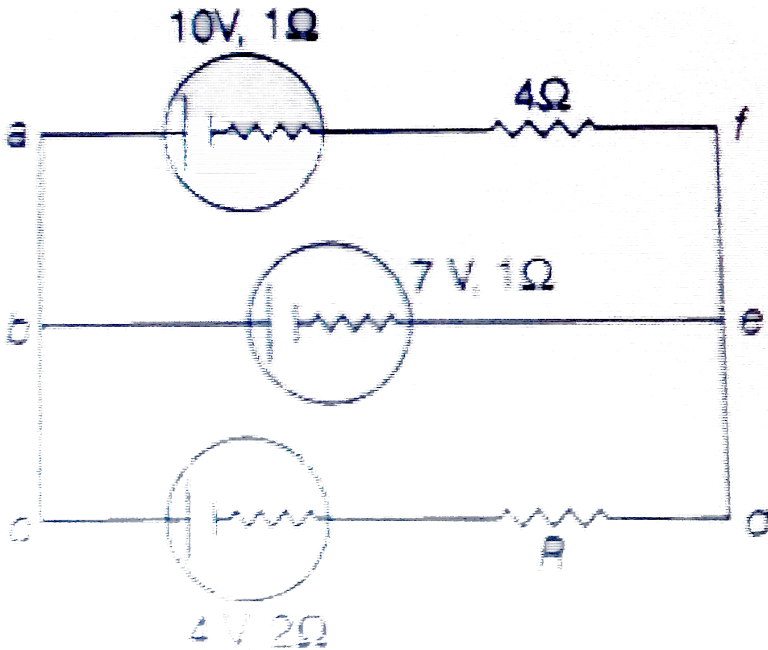

For what value of R, current through 7V battery is zero?

A. 10.6 V, 7 V, 2.8 V

B. 9.4 V, 7 V, 5.2 V

C. 9.4 V, 0, 5.2 V

D. 10.6 V, 0, 2.8 V

Answer: B

 [Watch Video Solution](#)

129. In series, potential difference distributes in direct ratio of resistance and in parallel current is distributed in inverse ratio of resistance

In the circuit shown in figure

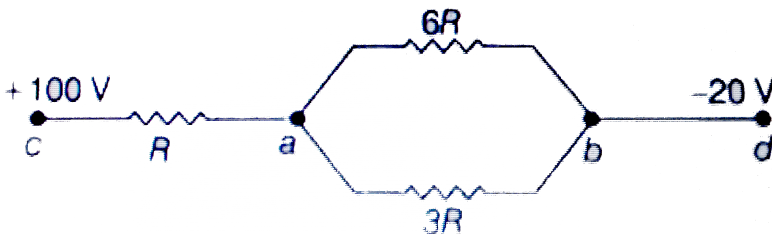

A. $V_a = 40V$

B. $V_b = 20V$

C. both (a) and (b) are correct

D. both (a) and (b) wrong

Answer: D



Watch Video Solution

130. In series, potential difference distributes in direct ratio of resistance and in parallel current is distributed in inverse ratio of resistance

Ratio of current through R , $6R$ and $3R$ will be

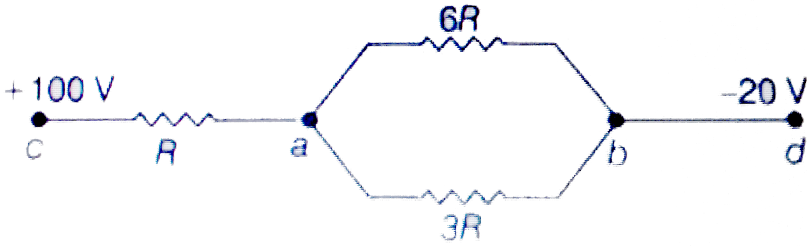

A. $5 : 2 : 3$

B. $3 : 1 : 2$

C. $4 : 1 : 3$

D. $3 : 2 : 1$

Answer: B



[Watch Video Solution](#)

131. In the circuit shown in figure points a, b and c are maintained at constant (but may be different) potentials. When

a resistance is connected between a and b no current flows through it, when the same resistance is connected between b and c current flows from c to b.

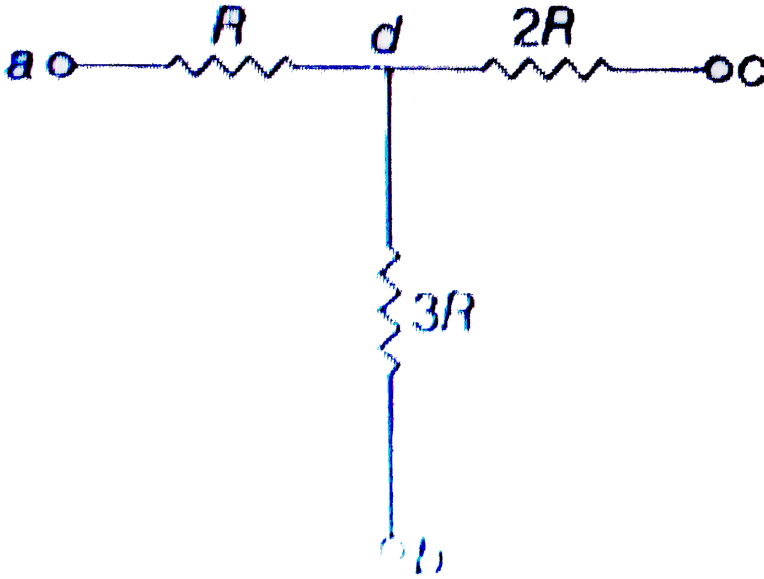

When only three resistance shown in figure are in the circuit

- A. A) current in resistance $2R$ is from c to d
- B. B) current in $2R$ is four times the current in R
- C. C) both (a) and (b) are correct
- D. D) both (a) and (b) wrong

Answer: A



Watch Video Solution

132. In the circuit shown in figure points a, b and c are maintained at constant (but may be different) potentials. When a resistance is connected between a and b no current flows through it, when the same resistance is connected between b and c current flows from c to b.

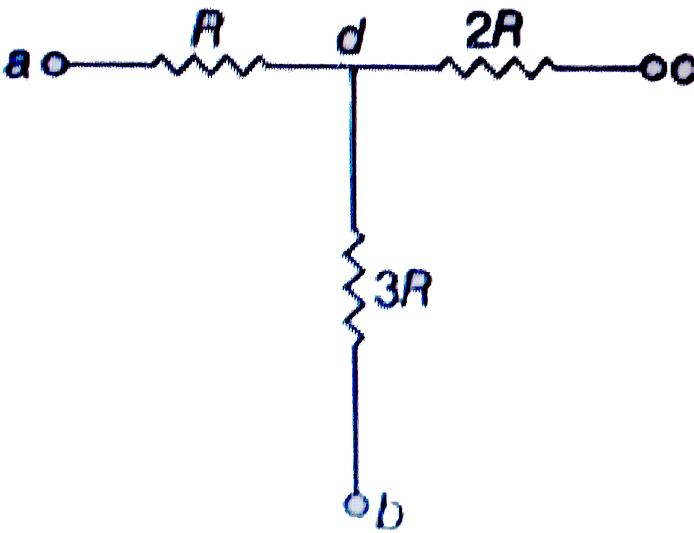

If $V_a = V_b = 10V$ and $V_c = 30V$. Then value of V_d will be

- A. $\frac{165}{9}V$
- B. $\frac{170}{11}V$
- C. $\frac{154}{8}V$
- D. $\frac{185}{13}V$

Answer: B

 [Watch Video Solution](#)

133. All bulbs consume same power. The resistance of bulb 1 is 36Ω . Answer the following questions:

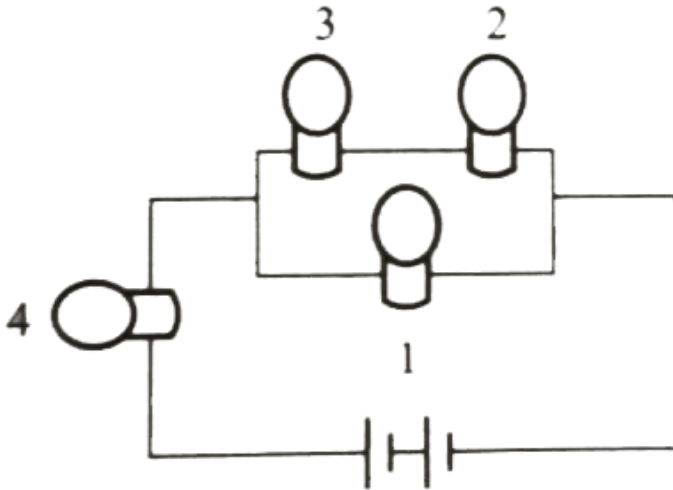

What is the resistance of bulb 3?

- A. 4Ω
- B. 9Ω
- C. 12Ω
- D. 18Ω

Answer: B

 Watch Video Solution

134. All bulbs consume same power. The resistance of bulb 1 is 36Ω . Answer the following questions:

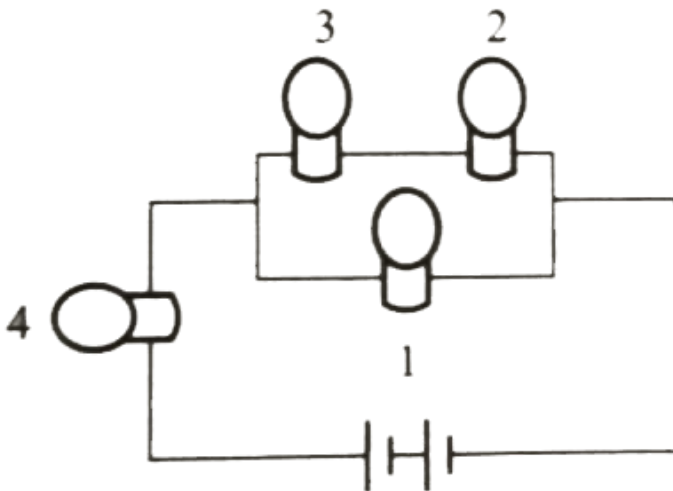

What is the resistance of bulb 4?

A. 4Ω

B. 9Ω

C. 12Ω

D. 18Ω

Answer: A

 [Watch Video Solution](#)

135. All bulbs consume same power. The resistance of bulb 1 is 36Ω . Answer the following questions:

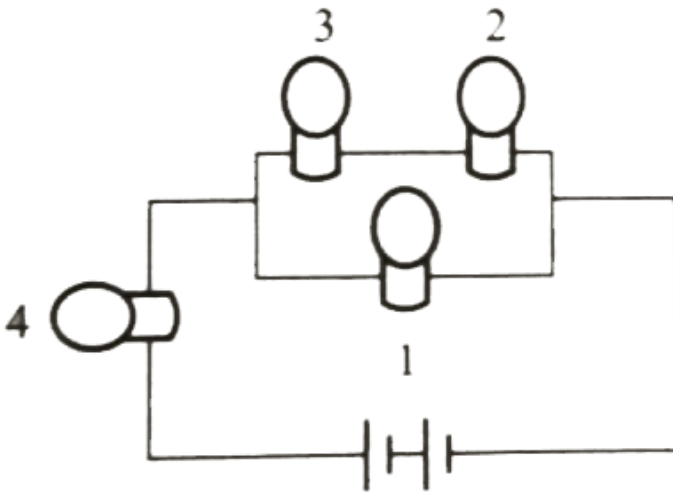

What is the voltage output of the battery if the power of each bulb is $4W$?

A. A) 12 V

B. B) 16 V

C. C) 24 V

D. D) 24 V

Answer: B



[Watch Video Solution](#)

136. The power dissipated in resistor R_3 shown in the figure is 15 W. The reading the ammeter is 500 mA and the reading of the voltmeter is 10 V. Ammeter, voltmeter and battery are ideal.

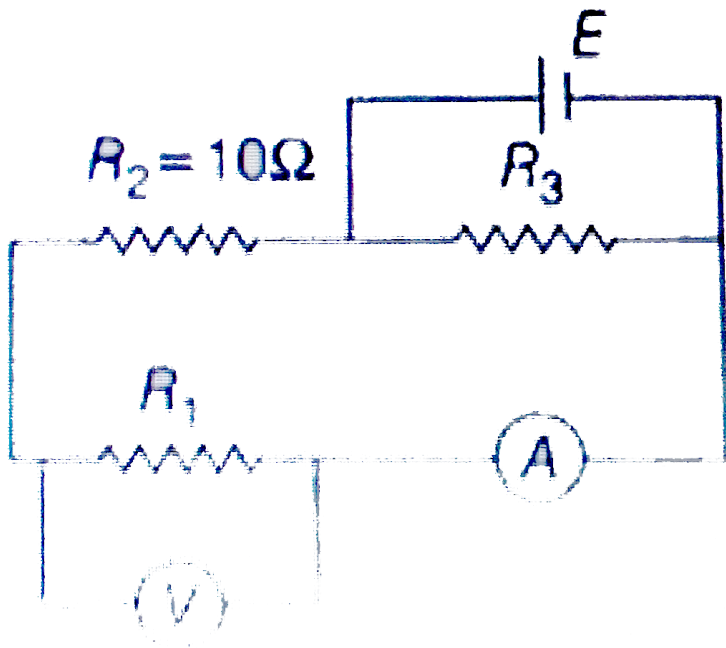

What is the emf E of the supply battery?

- A. A) 10Ω
- B. B) 15Ω
- C. C) 20Ω
- D. D) 25Ω

Answer: C

137. The power dissipated in resistor R_3 shown in the figure is 15 W. The reading the ammeter is 500 mA and the reading of the voltmeter is 10 V. Ammeter, voltmeter and battery are ideal.

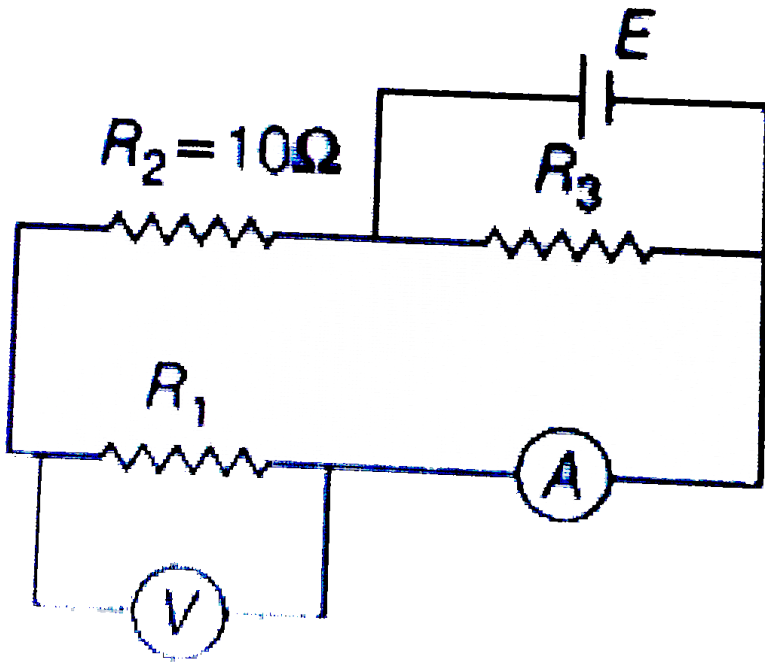

Find the resistance R_3

A. A) 10Ω

B. B) 7.5Ω

C. C) 20Ω

D. D) 25Ω

Answer: B

 [Watch Video Solution](#)

138. The power dissipated in resistor R_3 shown in the figure is 15 W. The reading the ammeter is 500 mA and the reading of the voltmeter is 10 V. Ammeter, voltmeter and battery are ideal.

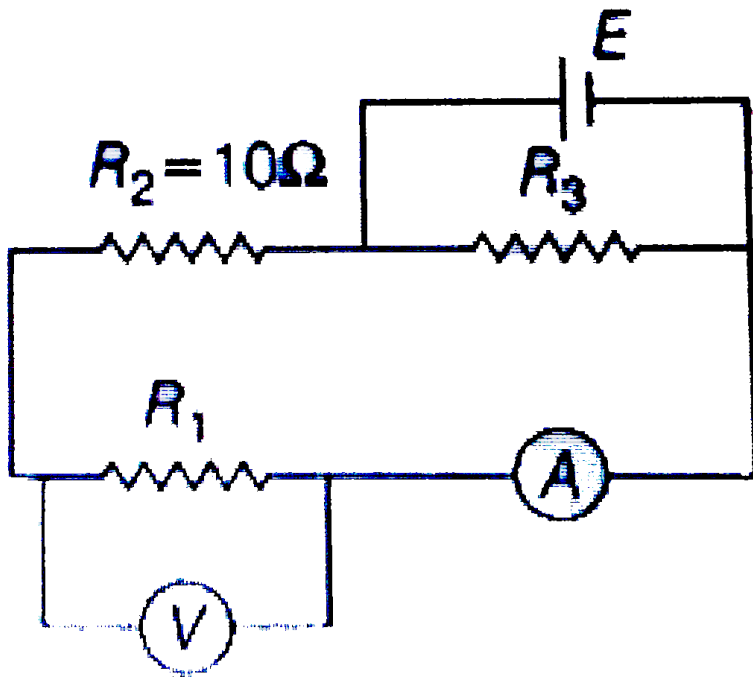

Find the resistance R_1

- A. 10 V
- B. 15 V
- C. 20 V
- D. 25Ω

Answer: c

139. Match the following

Table-1	Table-2
(A) Kw-h	(P) Conservation laws
(B) Kirchhoff's law	(Q) Vit
(C) Force \times velocity	(R) $\frac{V}{i} = \text{constant}$
(D) Ohm's law	(S) Vi

140. Three wires of same material are connected in parallel to a source of emf. The length ratio of the wires is 1:2:3 and the ratio of their area of cross section is 2:4:1 then match the

following

Table-1	Table-2
(A) Resistance ratio	(P) 6 : 6 : 1
(B) Current ratio	(Q) 1 : 6 : 6
(C) Power ratio	(R) 1 : 1 : 6
	(S) None

 **Watch Video Solution**

141. In the figure shown, each resistance is R . Match the following

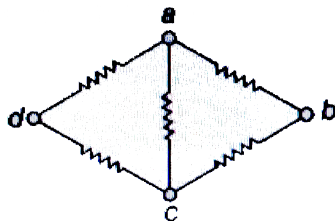

Table-1	Table-2
(A) Resistance between a and b	(P) $\frac{R}{2}$
(B) Resistance between a and c	(Q) $\frac{5}{8} R$
(C) Resistance between b and d	(R) R
	(S) None



Watch Video Solution

142. Six batteries of increasing emf and increasing internal resistance are as shown in figure. Match the following

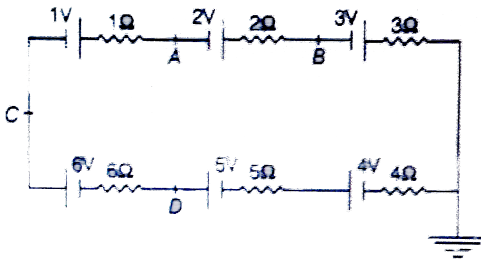

Table-1

- (A) Potential of point A
- (B) Potential of point B
- (C) Potential of point C
- (D) Potential of point D

Table-2

- (P) Zero
- (Q) 2 V
- (R) 4 V
- (S) 6 V
- (T) None



Watch Video Solution

143. In the potentiometer arrangement shown in figure null point is obtained. Match the following

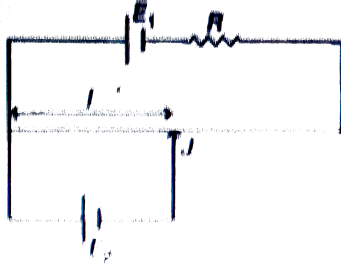

Table-1

- (A) If E_1 is increased
- (B) If R is increased
- (C) If E_2 is increased

Table-2

- (P) I should increase
- (Q) I should decrease
- (R) I should remain the same to again get the null point

[▶ Watch Video Solution](#)

144. In the circuit shown in figure, if a resistance R connected in parallel with R_2 , then match following

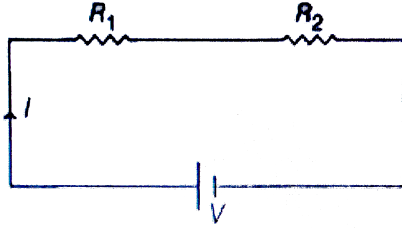

Table-1

- (A) Main current I
- (B) Power across R_1
- (C) Power across R_2

Table-2

- (P) will increase
- (Q) will decrease
- (R) will remain same

 [Watch Video Solution](#)

145. In the circuit shown in figure, match following.

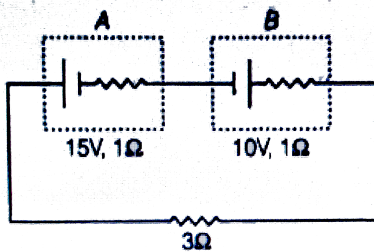

Table-1	Table-2
(A) Potential difference across battery A	(P) A
(B) Potential difference across battery B	(Q) B
(C) Power is supplied by battery	(R) 14 V
(D) Power is consumed by battery	(S) 9 V
	(T) None

 Watch Video Solution

146. Current is flowing through a wire of non-uniform cross section. Cross section of wire at A is less than the cross section of

wire at B. Then match the following

Table-1	Table-2
(A) current at A	(P) is zero
(B) drift velocity of electrons at A	(Q) is more than at B
(C) electric field in the wire at A	(R) is less than at B
(D) current density at A	(S) is equal to that at B

 Watch Video Solution

147. In the circuit shown in figure, $R_1 = R_2 = R_3 = R$. Match the following

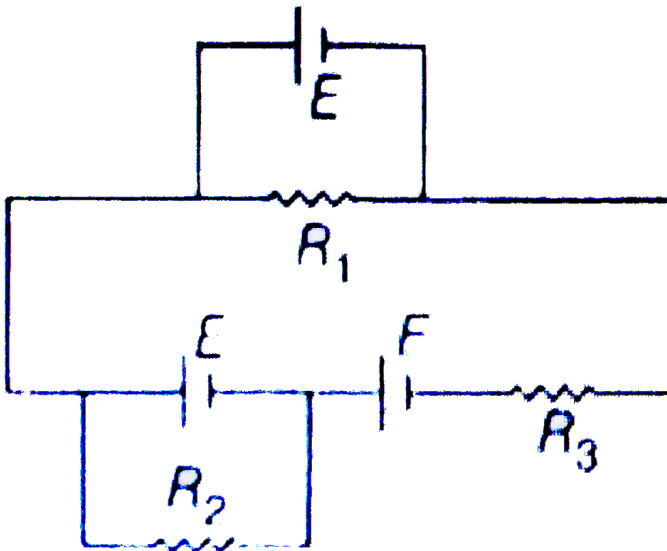

148. In the circuit shown in figure, match the match the following

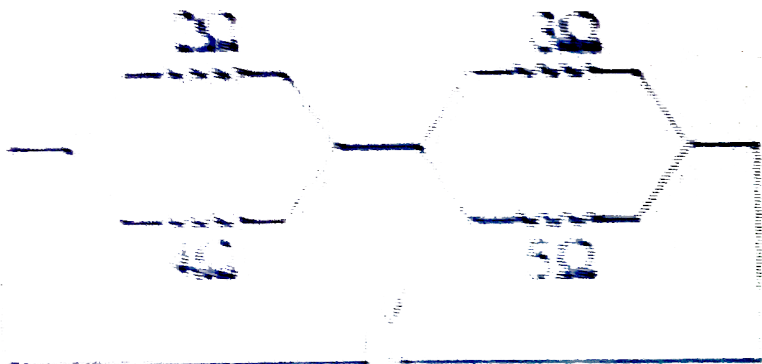

Table-1	Table-2
(A) Minimum current will flow through	(P) $2\ \Omega$
(B) Maximum current will flow through	(Q) $4\ \Omega$
(C) Maximum power will be generated across	(R) $3\ \Omega$
(D) Minimum power will be generated across	(S) $5\ \Omega$

149. the following table gives the lengths of four copper rods at the temperature ,their diameters and the potential differences between their ends.

Rod	Length	Diameter	Potential Difference
1	L	3d	V
2	2L	d	3V
3	3L	2d	2V
4	3L	d	V

Table-1		Table-2	
(A)	Greatest drift speed of the electrons	(P)	Rod 1
(B)	Greatest current	(Q)	Rod 2
(C)	Greatest rate of thermal energy produced	(R)	Rod 3
(D)	Greatest electric field	(S)	Rod 4

 **Watch Video Solution**

150. the current in a circuit containing a battery connected to 2Ω resistance is $0.9A$. When ana additional resistance of 8Ω is

connected to the same battery the current observed in the circuit is $0.3A$. Then the internal resistance of the battery is $x\Omega$.

Find value of x .

[▶ Watch Video Solution](#)

151. Equivalent resistance between points A and B is $0.5xR$. Find value of x .

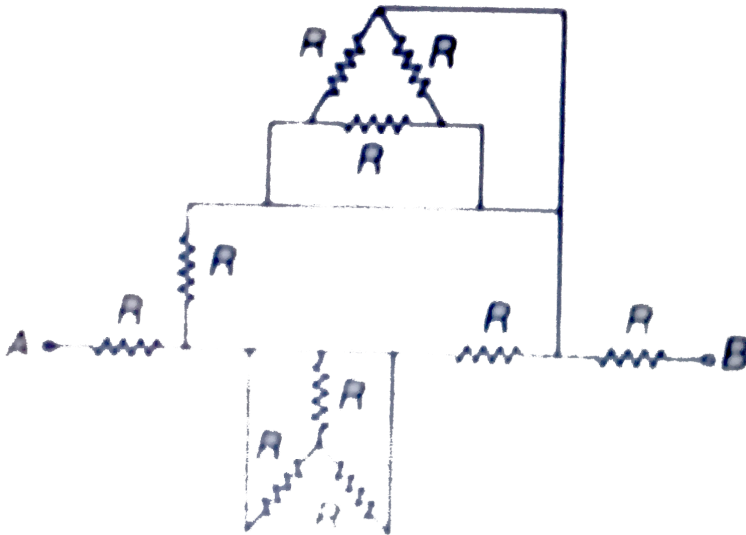

[▶ Watch Video Solution](#)

152. Three electric bulbs of 200 W and 400 W are shown in figure. The resultant power of the combination if rated voltage is applied across the combination is $(50x)$ Watt. Find value of x .

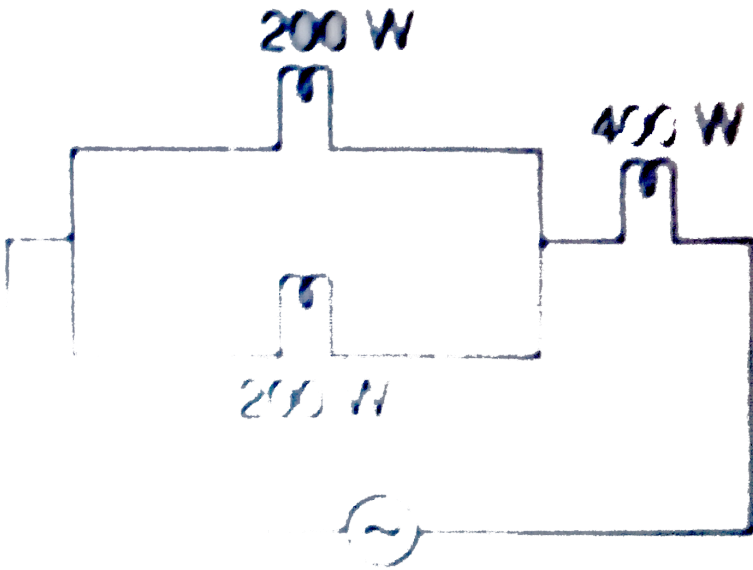

[Watch Video Solution](#)

153. In the circuit shown in figure, a voltmeter of internal resistance R , when connected across B and C reads $\frac{100}{3}V$. Neglect the internal resistance of the battery the value of R is $(5x)k\Omega$. Find value of x .

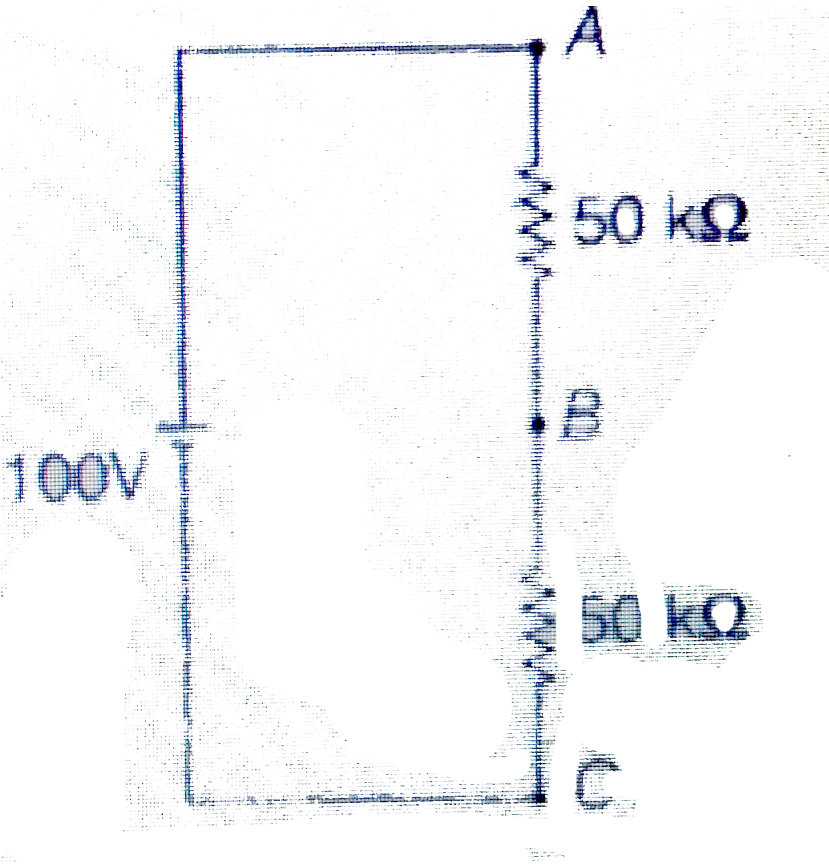

[Watch Video Solution](#)

154. An electric current of $16A$ exists in a metal wire of cross section $10^{-6}M^2$ and length $1m$. Assuming one free electron per atom. The drift speed of the free electron in the wire will be $(0.00x)m/s$. Find value of x .

(Density of metal = $5 \times 10^3 kg/m^3$, atomic weight = 60)

 [Watch Video Solution](#)

155. Two wires A and B made of same material and having their lengths in the ratio $6:1$ are connected in series. The potential difference across the wire $3V$ and $2V$ respectively. If r_A and r_B are the radii of A and B respectively, then $\frac{r_B}{r_A}$ is

 [Watch Video Solution](#)

156. In the given circuit diagram find the potential difference across 2Ω resistance (in volts).

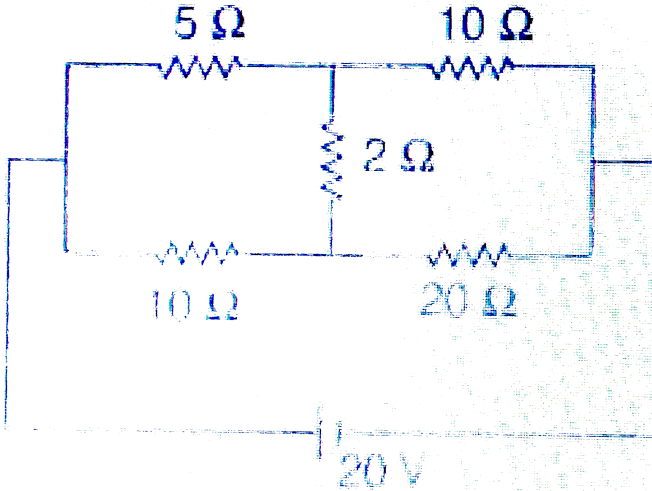

[▶ Watch Video Solution](#)

157. In the circuit shown in figure, the ratio of currents i_1/i_2 is

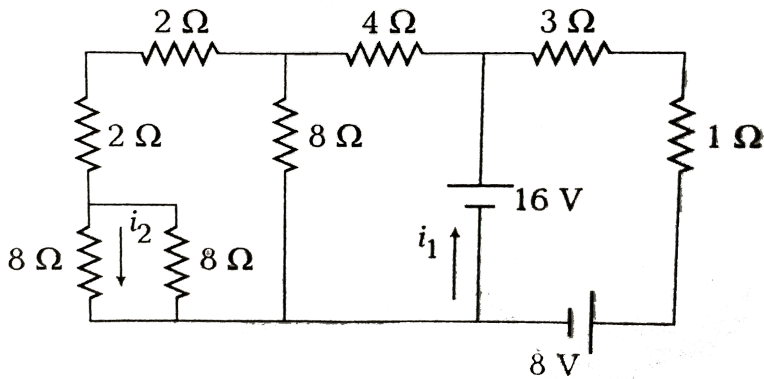

[Watch Video Solution](#)

158. Find the current (in ampere) through wire XY of the circuit shown in figure.

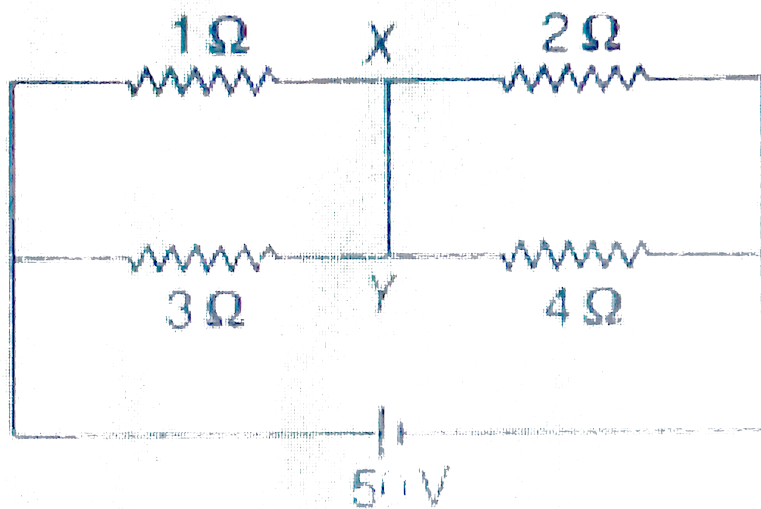

[Watch Video Solution](#)

159. the current in resistance R_3 in the given circuit is $\frac{2}{x}$ A. Find the value of x.

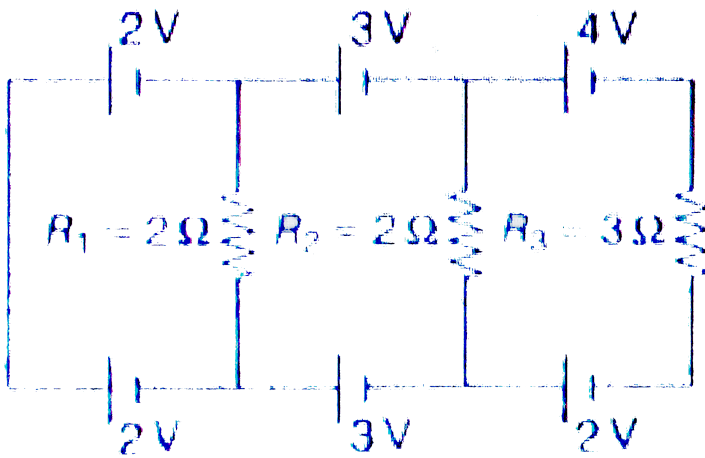

 Watch Video Solution

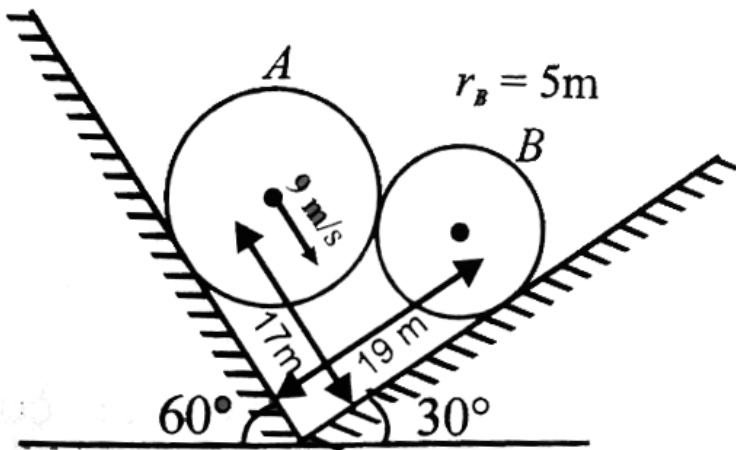

160.

System is shown in the figure. Velocity of sphere A is $9\frac{m}{s}$. Find

the speed of sphere B.

[▶ Watch Video Solution](#)

161. For the potentiometer arrangement shown in the figure, length of wire AB is 100 cm and its resistance is 9Ω . Find the length AC for which the galvanometer G will show zero deflection.

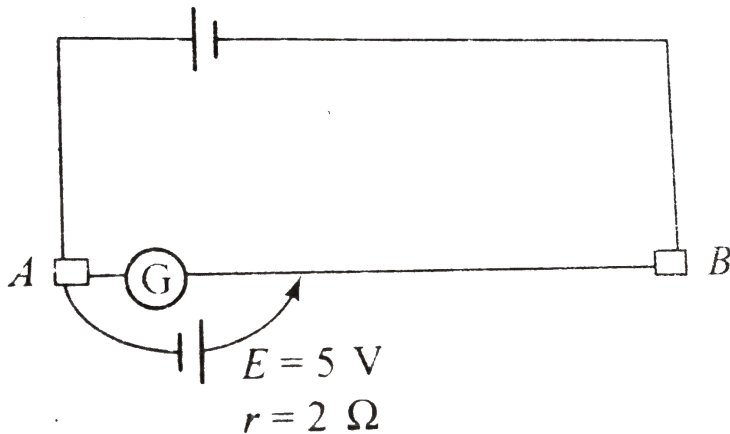

[▶ Watch Video Solution](#)

162. For the arrangement of the potentiometer shown in the figure, The balance point is obtained at a distance 75cm from A when the key k is open

The second balance point is obtained at 60cm from A when the key k is closed. Find the internal resistance of the battery E_1 .

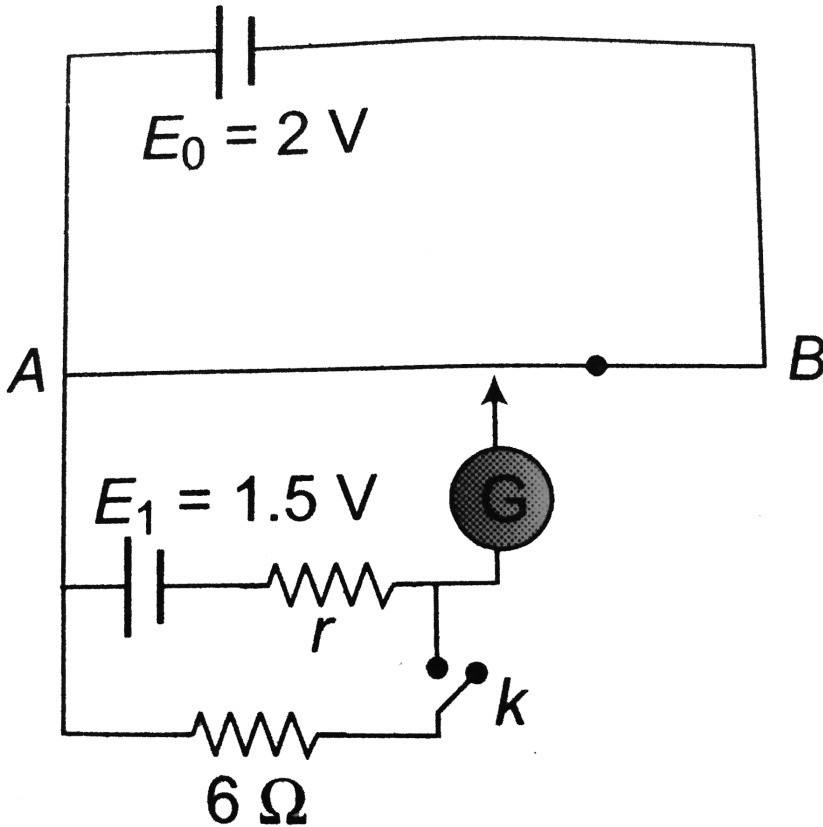

[Watch Video Solution](#)

163. the current developed in a real conductor is given $I = aV^{1/2}$, where V is the potential difference across the conductor. When it is connected with resistance of $R\Omega$ in series with a battery of 6 volt shown in the figure, the power developed in conductor is twice the power generated in resistance of $R\Omega$. find the value of R . [$a = 0.2AVolt^{-1/2}$]

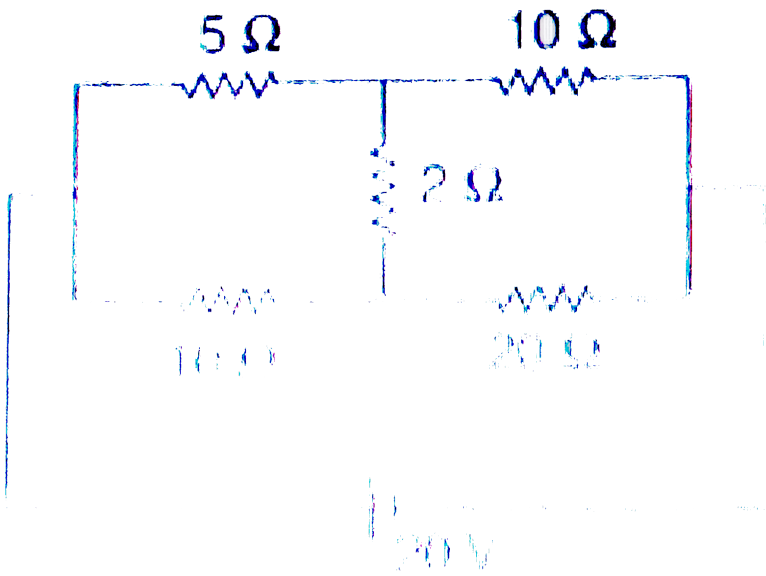

[Watch Video Solution](#)

164. The resistance of a series combination of the resistance is S . when they are joined in parallel equivalent resistance is P . Find the value of $\left(\frac{S}{2P}\right)$



Watch Video Solution