



PHYSICS

BOOKS - DC PANDEY ENGLISH

MOTION

Solved Example

1. A particle moves in a plane such that its coordinates changes with time as $x = at$ and $y = bt$, where a and b are constants. Find the position vector of the particle and its direction at any time t .

[Watch Video Solution](#)

2. An object moves from position (3,4) to (6,5) in the xy-plane. Find the magnitude and direction of displacement vector of the particle.



[Watch Video Solution](#)

3. A particle moves in xy-plane from position (1m,2m) to (3m,4m) in 2s. Find the magnitude and direction of average velocity.



[Watch Video Solution](#)

4. Position vector of a particle is given as

$r = 2t\hat{i} + 3t^2\hat{j}$ where t is in second and the coefficients have the proper units, for r to be in metres.

(i) Find instantaneous velocity $v(t)$ of the particle.

(ii) Find magnitude and direction of $v(t)$ at $t = 2s$



Watch Video Solution

5. Velocity of a particle changes from $(3\hat{i} + 4\hat{j})\text{ m/s}$ to $(6\hat{i} + 5\hat{j})\text{ m/s}$ in 2s. Find magnitude and direction of average acceleration.



Watch Video Solution

6. The position of a particle is given by

$$r = 3t\hat{i} + 2t^2\hat{j} + 8\hat{k}$$

where, t is in seconds and the coefficients have the proper units for r to be in metres.

(i) Find $v(t)$ and $a(t)$ of the particles.

(ii) Find the magnitude and direction of $v(t)$ and $a(t)$ at $t = 1\text{ s}$.



Watch Video Solution

7. A particle starts from origin at $t = 0$ with a velocity of $15\hat{i}ms^{-1}$ and moves in xy-plane under the action of a force which produces a constant acceleration of $15\hat{i} + 20\hat{j}ms^{-2}$. Find the y-coordinate of the particle at the instant its x-coordinate is 180 m.



[Watch Video Solution](#)

8. An object has a velocity, $v = (2\hat{i} + 4\hat{j})ms^{-1}$ at time $t = 0s$. It undergoes a constant acceleration $a = (\hat{i} - 3\hat{j})ms^{-2}$ for 4s.

Then

- (i) Find the coordinates of the object if it is at origin at $t = 0$
- (ii) Find the magnitude of its velocity at the end of 4s.



[Watch Video Solution](#)

9. A body is projected with a velocity of 20ms^{-1} in a direction making an angle of 60° with the horizontal. Determine its (i) position after 0.5 s and (ii) the velocity after 0.5s.

 [Watch Video Solution](#)

10. A stone is thrown with a speed of 10ms^{-1} at an angle of projection 60° . Find its height above the point of projection when it is at a horizontal distance of 3m from the thrower ? (Take $g = 10\text{ms}^{-2}$)

 [Watch Video Solution](#)

11. A cricket ball is thrown at a speed of 28ms^{-1} in a direction 30° above the horizontal. Calculate (a) the maximum height (b) the time taken by ball to return to the same level, and (c) the distance

from the thrower to the point where the ball returns to the same level.

 [Watch Video Solution](#)

12. Assume that a ball is kicked at an angle of 60° with the horizontal, so if the horizontal component of its velocity is 19.6ms^{-1} , determine its maximum height.

 [Watch Video Solution](#)

13. An object is projected with a velocity of 30ms^{-1} at an angle of 60° with the horizontal. Determine the horizontal range covered by the object.

 [Watch Video Solution](#)

14. A projectile has a range of $40m$ and reaches a maximum height of $10m$. Find the angle at which the projectile is fired.

 [Watch Video Solution](#)

15. Find the angle of projection of a projectile for which horizontal range and maximum height are equal.

 [Watch Video Solution](#)

16. There are two angles of projection for which the horizontal range is the same. Show that the sum of the maximum heights for these two angles is independent of the angle of projection.

 [Watch Video Solution](#)

17. Prove that the maximum horizontal range is four times the maximum height attained by the projectile, when fired at an inclination so as to have maximum horizontal range.

 [Watch Video Solution](#)

18. A football is kicked at an angle of 30° with the vertical, so if the horizontal component of its velocity is $20ms^{-1}$, determine its maximum height.

 [Watch Video Solution](#)

19. A bomb is released from an aeroplane flying at a speed of $720km/h$ in the horizontal direction $8000m$ above the ground. At what horizontal distance from the initial position of aeroplane it strikes the ground.



[Watch Video Solution](#)

20. A body is thrown horizontally from the top of a tower and strikes the ground after three seconds at an angle of 45° with the horizontal. Find the height of the tower and the speed with which the body was projected. (Take $g = 9.8m/s^2$)



[Watch Video Solution](#)

21. A body is thrown horizontally from the top of a tower and strikes the ground after three seconds at an angle of 45° with the horizontal. Then find

(i) the height of the tower

(ii) the speed of projection of the body



[Watch Video Solution](#)

22. A projectile is fired horizontally with velocity of 98 m/s from the top of a hill 490 m high. Find

(a) the time taken by the projectile to reach the ground,

(b) the distance of the point where the particle hits the ground from foot of the hill and

(c) the velocity with which the projectile hits the ground.

$$(g = 9.8 \text{ m/s}^2)$$

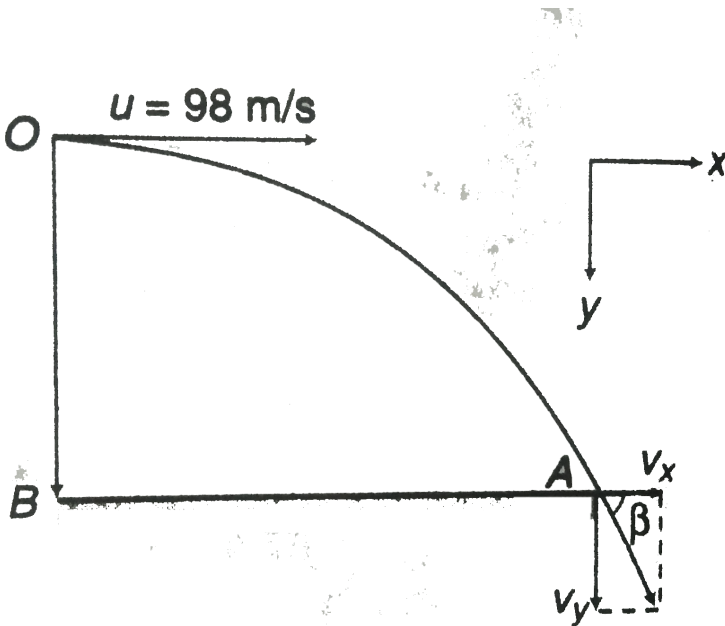

 Watch Video Solution

23. A boy playing on the roof of a $10m$ high building throws a ball with a speed of $10m/s$ at an angle of 30° with the horizontal. How far from the throwing point will the ball be at the height of $10m$ from the ground ?

$$\left[g = 10m/s^2, \sin 30^\circ = \frac{1}{2}, \cos 30^\circ = \frac{\sqrt{3}}{2} \right]$$

 [Watch Video Solution](#)

24. A boy standing on the top of a tower $36m$ high has a throw a packet to his friend standing on the ground $48m$ horizontally away. If he throws a packet directly aiming the friend with a speed of $10ms^{-1}$, how short will be packet fall ?

 [Watch Video Solution](#)

1. The x and y components of a position vector P have numerical values 5 and 6 respectively. Direction and magnitude of vector P are

A. $\tan^{-1}\left(\frac{6}{5}\right)$ and $\sqrt{61}$

B. $\tan^{-1}\left(\frac{5}{6}\right)$ and $\sqrt{61}$

C. 60° and 8

D. 30° and 9

Answer: A



[Watch Video Solution](#)

2. An object moves from position (6,8) to (12,10) in the x-y plane.

Magnitude and direction of displacement is

A. $\sqrt{40}$ and 18.43°

B. $\sqrt{40}$ and 61.56°

C. 10 and 53°

D. $\sqrt{244}$ and 53°

Answer: A

 [Watch Video Solution](#)

3. A particle moves in xy-plane from position (2m, 4m) to (6m,8m) in 2s. Magnitude and direction of average velocity is

A. $\sqrt{2}ms^{-1}$ and 45°

B. $2\sqrt{2}ms^{-1}$ and 45°

C. $4\sqrt{2}ms^{-1}$ and 30°

D. $3\sqrt{2}ms^{-1}$ and 60°

Answer: B

 [Watch Video Solution](#)

4. The distance travelled by an object along the axes are given by $x = 2t^2$, $y = t^2 - 4t$, $z = 3t - 5$. The initial velocity of the particle is .

- A. 10 units
- B. 12 units
- C. 5 units
- D. 2 units

Answer: C

 [Watch Video Solution](#)

5. A particle moves along the positive branch of the curve $y = \frac{x^2}{2}$ where $x = \frac{t^2}{2}$, x and y are measured in metres and t in second.

At $t = 2s$, the velocity of the particle is

A. $2\hat{i} - 4\hat{j}ms^{-1}$

B. $4\hat{i} + 2\hat{j}ms^{-1}$

C. $2\hat{i} + 4\hat{j}ms^{-1}$

D. $4\hat{i} - 2\hat{j}ms^{-1}$

Answer: C

 [Watch Video Solution](#)

6. The position vector of a particle is $r = a \sin \omega t \hat{i} + a \cos \omega t \hat{j}$

The velocity of the particle is

A. parallel to position vector

B. perpendicular to position vector

C. directed towards origin

D. directed away from the origin

Answer: B



Watch Video Solution

7. The position vector of an object at any time t is given by

$3t^2\hat{i} + 6t\hat{j} + \hat{k}$. Its velocity along y-axis has the magnitude

A. $6t$

B. 6

C. 0

D. 9

Answer: B

 [Watch Video Solution](#)

8. The height y and distance x along the horizontal plane of a projectile on a certain planet are given by $x = 6tm$ and $y = (8t - 5t^2)m$. The velocity with which the projectile is projected is

A. $8ms^{-1}$

B. $9ms^{-1}$

C. $10ms^{-1}$

D. $(10/3)ms^{-1}$

Answer: C

 [Watch Video Solution](#)

9. The co-ordinates of a moving particle at any time t are given by

$x = ct^2$ and $y = bt^2$. The speed of the particle is

A. $2t\sqrt{c^2 + b^2}$

B. $\frac{2t}{\sqrt{c^2 + b^2}}$

C. $t\sqrt{c^2 + b^2}$

D. $\frac{t}{\sqrt{c^2 + b^2}}$

Answer: A



[Watch Video Solution](#)

10. The coordinates of a moving particle at any time t are given by,

$x = 2t^3$ and $y = 3t^3$. Acceleration of the particle is given by

A. $468t$

B. $t\sqrt{468}$

C. $234t^2$

D. $t\sqrt{234}$

Answer: B



Watch Video Solution

11. The position of a particle moving in the xy plane at any time t is given by $x = (3t^2 - 6t)$ metres, $y = (t^2 - 2t)$ metres. Select the correct statement about the moving particle from the following

A. The acceleration of the particle is zero at $t = 0s$

B. The velocity of the particle is zero at $t = 0s$

C. The velocity of the particle is zero at $t = 1s$

D. The velocity and acceleration of the particle are zero

Answer: C

 [Watch Video Solution](#)

12. A particle's velocity changes from $(2\hat{i} + 3\hat{j})ms^{-1}$ in to $(3\hat{i} - 2\hat{j})ms^{-1}$ in 2s. Its average acceleration in ms^{-2} is

A. $-(\hat{i} + 5\hat{j})$

B. $(\hat{i} + 5\hat{j})/2$

C. zero

D. $(\hat{i} - 5\hat{j})/2$

Answer: D

 [Watch Video Solution](#)

13. A particle has an initial velocity of $4\hat{i} + 3\hat{j}$ and an acceleration of $0.4\hat{i} + 0.3\hat{j}$. Its speed after 10s is

- A. 10 units
- B. 7 units
- C. $7\sqrt{2}$ units
- D. 8.5 units

Answer: A



[Watch Video Solution](#)

14. A body lying initially at point (3,7) starts moving with a constant acceleration of $4\hat{i}$. Its position after 3s is given by the coordinates

A. (7,3)

B. (7,18)

C. (21,7)

D. (3,7)

Answer: C

 [Watch Video Solution](#)

15. The initial position of an object at rest is given by $3\hat{i} - 8\hat{j}$. It moves with constant acceleration and reaches to the position $2\hat{i} + 4\hat{j}$ after 4s. What is its acceleration ?

A. $-\frac{1}{8}\hat{i} + \frac{3}{2}\hat{j}$

B. $2\hat{i} - \frac{1}{8}\hat{j}$

C. $-\frac{1}{2}\hat{i} + 8\hat{j}$

D. $8\hat{i} - \frac{3}{2}\hat{j}$

Answer: A

 [Watch Video Solution](#)

Check Point 4.2

1. At the top of the trajectory of a projectile, the directions of its velocity and acceleration are

- A. parallel to each other
- B. antiparallel to each other
- C. inclined to each other at an angle of 45°
- D. perpendicular to each other

Answer: D



[Watch Video Solution](#)

2. At the top of the trajectory of a projectile, the directions of its velocity and acceleration are

- A. maximum
- B. minimum
- C. zero
- D. g

Answer: D



[Watch Video Solution](#)

3. In the motion of a projectile freely under gravity, its

- A. total mechanical energy is conserved
- B. momentum is conserved
- C. mechanical energy and momentum both are conserved
- D. None is conserved

Answer: A

 [Watch Video Solution](#)

4. When a stone is projected which remains constant?

- A. Angular momentum
- B. Linear momentum
- C. Vertical component of velocity
- D. Horizontal component of velocity

Answer: D

 [Watch Video Solution](#)

5. A stone is projected with speed of 50ms^{-1} at an angle of 60° with the horizontal. The speed of the stone at highest point of trajectory is

A. 75ms^{-1}

B. 25ms^{-1}

C. 50ms^{-1}

D. cannot find

Answer: B

 [Watch Video Solution](#)

6. A football player throws a ball with a velocity of $50m/s$ at an angle 30 degrees from the horizontal. The ball remains in the air for ($g = 10m/s^2$)

A. $2.5s$

B. $1.25s$

C. $5s$

D. $0.625s$

Answer: C

 [Watch Video Solution](#)

7. A particle is projected with a velocity of $20ms^{-1}$ at an angle of 60° to the horizontal. The particle hits the horizontal plane again during its journey. What will be the time of impact ?

A. $3.53s$

B. $2.4s$

C. $1.7s$

D. $1s$

Answer: A



Watch Video Solution

8. If 2 balls are projected at angles 45° and 60° and the maximum heights reached are same, what is the ratio of their initial velocities ?

A. $\sqrt{2} : \sqrt{3}$

B. $\sqrt{3} : \sqrt{2}$

C. $3 : 2$

D. 2:3

Answer: B



Watch Video Solution

9. If the initial velocity of a projectile be doubled, keeping the angle of projection same, the maximum height reached by it will

- A. remain the same
- B. be doubled
- C. become four times
- D. be halved

Answer: C



Watch Video Solution

10. For a projectile, the ratio of maximum height reached to the square of flight time is ($g = 10ms^{-2}$)

A. 5:4

B. 5:2

C. 5:1

D. 10:1

Answer: A



[Watch Video Solution](#)

11. A particle is projected from ground with speed u and at an angle θ with horizontal. If at maximum height from ground, the speed of particle is $1/2$ times of its initial velocity of projection, then find its maximum height attained.

A. $\frac{u^2}{g}$

B. $\frac{2u^2}{g}$

C. $\frac{u^2}{2g}$

D. $\frac{3u^2}{8g}$

Answer: D



Watch Video Solution

12. A projectile, thrown with velocity v_0 at an angle α to the horizontal, has a range R . It will strike a vertical wall at a distance $R/2$ from the point of projection with a speed of

A. v_0

B. $v_0 \sin \alpha$

C. $v_0 \cos \alpha$

D. $\sqrt{\frac{gR}{2}}$

Answer: C

 [Watch Video Solution](#)

13. A particle is projected at an angle of 45° with a velocity of $9.8ms^{-1}$. The horizontal range will be (Take, $g = 9.8ms^{-2}$)

A. $9.8m$

B. $4.9m$

C. $\frac{9.8}{\sqrt{2}}m$

D. $9.8\sqrt{2}m$

Answer: A

 [Watch Video Solution](#)

14. Two projectiles are fired from the same point with the same speed at angles of projection 60° (B) and 30° (A) respectively.

Which one of the following is true?

A. $R_A = R_B$

B. $H_B = 3H_A$

C. $T_B = \sqrt{3}T_A$

D. None of these

Answer: D



[Watch Video Solution](#)

15. A projectile fired with initial velocity u at some angle θ has a range R . If the initial velocity be doubled at the same angle of projection, then the range will be

A. $2R$

B. $R/2$

C. R

D. $4R$

Answer: D



Watch Video Solution

16. An object is thrown along a direction inclined at an angle of 45° with the horizontal direction. The horizontal range of the particle is equal to

A. vertical height

B. twice the vertical height

C. thrice the vertical height

D. four times the vertical height

Answer: D

 [Watch Video Solution](#)

17. An object is projected at an angle of 45° with the horizontal. The horizontal range and the maximum height reached will be in the ratio.

A. 1 : 2

B. 2 : 1

C. 1 : 4

D. 4 : 1

Answer: D

 [Watch Video Solution](#)

18. The horizontal range of a projectile is $4\sqrt{3}$ times its maximum height. Its angle of projection will be

A. 60°

B. 37°

C. 30°

D. 45°

Answer: C



[Watch Video Solution](#)

19. A ball is projected with a velocity $20\sqrt{3}ms^{-1}$ at angle 60° to the horizontal. The time interval after which the velocity vector will make an angle 30° to the horizontal is (Take, $g = 10ms^{-2}$)

A. 5s

B. 2s

C. 1s

D. 3s

Answer: B



[Watch Video Solution](#)

20. A projectile is thrown with a velocity of $10ms^{-1}$ at an angle of 60° with horizontal. The interval between the moments when speed is $\sqrt{5gm} / s$ is (Take, $g = 10ms^{-2}$)

A. 1s

B. 3s

C. 2s

D. 4s

Answer: C



[Watch Video Solution](#)

Check Point 4.3

1. A bomb is dropped from an aeroplane moving horizontally at constant speed. When air resistance is taken into consideration, the bomb

- A. falls on the earth exactly below the aeroplane
- B. falls on the earth behind the aeroplane
- C. falls on the earth ahead of the aeroplane
- D. flies with the aeroplane

Answer: A

 [Watch Video Solution](#)

2. A body is projected horizontally with a velocity of $4ms^{-1}$ from the top of a high tower. The velocity of the body after 0.7 is nearly (Take, $g = 10ms^{-2}$)

A. $10ms^{-1}$

B. $8ms^{-1}$

C. $19.2ms^{-1}$

D. $11ms^{-1}$

Answer: B

 [Watch Video Solution](#)

3. A particle is projected horizontally with speed 20m.s^{-1} from the top of a tower. After what time velocity of particle will be at 45° angle from initial direction of projection.

A. 1s

B. 2s

C. 3s

D. 4s

Answer: B



[Watch Video Solution](#)

4. An aeroplane is travelling at a height of 2000 m from the ground. The aeroplane, when at a point P, drops a bomb to hit a stationary target Q on the ground. In order that the bomb hits the target, what angle θ must the line PQ make with the vertical?

$$[g = 10\text{ms}^{-2}]$$

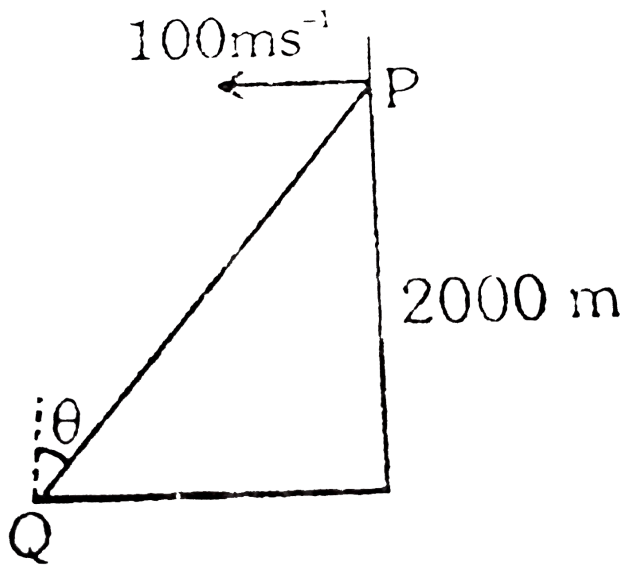

- A. 45°
- B. 30°
- C. 60°
- D. 90°

Answer: A

 [Watch Video Solution](#)

5. An aeroplane is flying at a constant height of 1960 m with speed 600kmh^{-1} above the ground towards point directly over a person struggling in flood water. At what angle of sight with the vertical should be pilot release a survival kit if it is to reach the person in water ? ($g = 9.8\text{ms}^{-2}$)

A. 45°

B. 30°

C. 60°

D. 90°

Answer: C



Watch Video Solution

6. A bomber moving horizontally with $500m/s$ drops a bomb which strikes ground in 10s. The angle of strike with horizontal is

A. $\tan^{-1}\left(\frac{1}{5}\right)$

B. 60°

C. 45°

D. $\tan^{-1}(5)$

Answer: A



Watch Video Solution

7. A ball is projected horizontal from the top of a tower with a velocity v_0 . It will be moving at an angle of 60° with the horizontal after time.

A. $\frac{v_0}{\sqrt{3}g}$

B. $\frac{\sqrt{3}v_0}{g}$

C. $\frac{v_0}{g}$

D. $\frac{v_0}{g}$

Answer: B



Watch Video Solution

8. An aeroplane is flying in a horizontal direction with a velocity $600\text{km}/h$ at a height of 1960 m . When it is vertically above the point A on the ground, a body is dropped from it. The body strikes the ground at point B. Calculate the distance AB.

A. 3.33km

B. 4.33km

C. 5.33km

D. 6.33km

Answer: A

 [Watch Video Solution](#)

9. A man standing on a hill top projects a stone horizontally with speed v_0 as shown in figure. Taking the co-ordinate system as given in the figure. Find the co-ordinates of the point where the

stone will hit the hill surface.

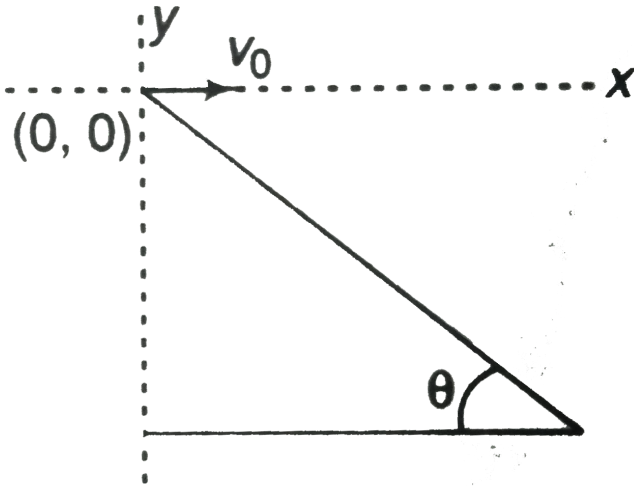

- A. $\left(\frac{2v_0^2 \tan \theta}{g}, -\frac{2v_0^2 \tan^2 \theta}{g} \right)$
- B. $\left(\frac{2v_0^2}{g}, -\frac{2v_0^2 \tan^2 \theta}{g} \right)$
- C. $\left(\frac{2v_0^2 \tan \theta}{g}, -\frac{2v_0^2}{g} \right)$
- D. $\left(\frac{2v_0^2 \tan^2 \theta}{g}, -\frac{2v_0^2 \tan \theta}{g} \right)$

Answer: A



Watch Video Solution

10. A ball is dropped from a height of 49 m. The wind is blowing horizontally. Due to wind a constant horizontal acceleration is provided to the ball. Choose the correct statement (s).

- A. Path of the ball is circular one
- B. Path of the ball is a curved one
- C. The time taken by the ball to reach the ground is 3.16 s
- D. Actual distance travelled by the ball is less than 49m

Answer: C



Watch Video Solution

A. Taking it together

1. In a two dimensional motion, instantaneous speed v_0 is a positive constant. Then which of the following are necessarily true?

- A. The average velocity is not zero at any time
- B. Average acceleration must always vanish
- C. Displacements in equal time intervals are equal
- D. Equal path lengths are traversed in equal intervals

Answer: D



Watch Video Solution

Taking it together

1. In a two dimensional motion, instantaneous speed v_0 is a positive constant. Then which of the following are necessarily true?

- A. The acceleration of the particle is zero
- B. The acceleration of the particle is bounded
- C. The acceleration of the particle is necessarily in the plane of motion
- D. The particle must be undergoing a uniform circular motion.

Answer: C

 [Watch Video Solution](#)

2. A particle velocity changes from $(2\hat{i} - 3\hat{j})ms^{-1}$ to $(3\hat{i} - 2\hat{j})ms^{-1}$ in 2s. If its mass is 1kg, the acceleration (ms^{-2})

is

A. $-(\hat{i} + \hat{j})$

B. $(\hat{i} + \hat{j})/2$

C. zero

D. $(\hat{i} - \hat{j})/2$

Answer: B



Watch Video Solution

3. Figure shows four paths for a kicked football. Ignoring the effects of air on the flight, rank the paths according to the initial

horizontal velocity component, highest first.

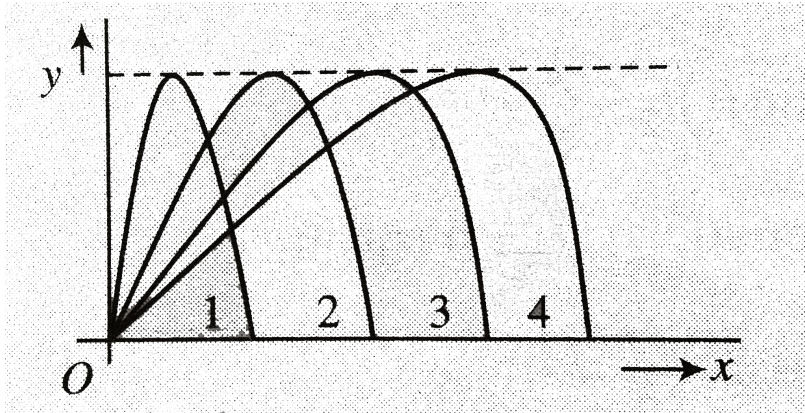

- A. 1,2,3,4
- B. 2,3,4,1
- C. 3,4,1,2
- D. 4,3,2,1

Answer: D



Watch Video Solution

4. Which of the following is the graph between the height (h) of a projectile and time (t), when it is projected from the ground

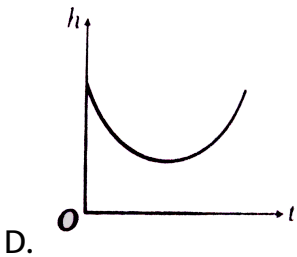
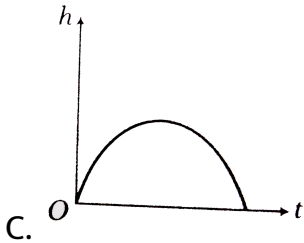
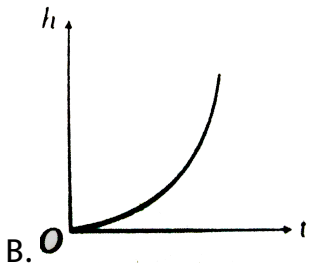
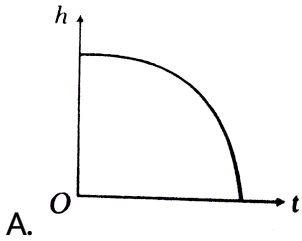

Answer: C

 Watch Video Solution

5. Which of the following is the altitude-time graph for a projectile thrown horizontally from the top of the tower

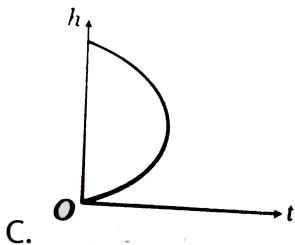
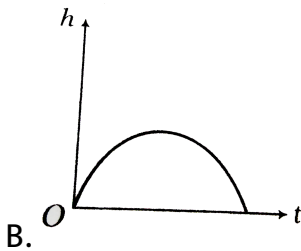
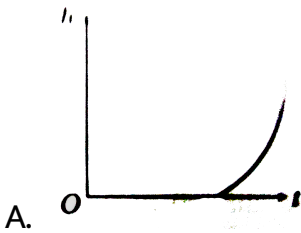

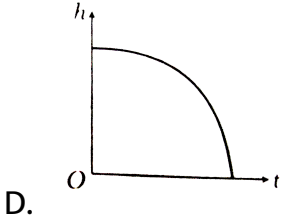

Answer: D

 [Watch Video Solution](#)

6. Two projectiles A and B are thrown from the same point with velocities v and $\frac{v}{2}$ respectively. If B is thrown at an angle 45° with horizontal. What is the inclination of A when their ranges are the same?

A. $\sin^{-1}\left(\frac{1}{4}\right)$

B. $\frac{1}{2}\sin^{-1}\left(\frac{1}{4}\right)$

C. $2\sin^{-1}\left(\frac{1}{4}\right)$

D. $\frac{1}{2}\sin^{-1}\left(\frac{1}{8}\right)$

Answer: D

 [Watch Video Solution](#)

7. Two stones having different masses m_1 and m_2 are projected at an angle α and $(90^\circ - \alpha)$ with same speed from same point. The ratio of their maximum heights is

A. 1 : 1

B. $1 : \tan \alpha$

C. $\tan \alpha : 1$

D. $\tan^2 \alpha : 1$

Answer: D

 [Watch Video Solution](#)

8. A projectile is thrown at an angle θ with the horizontal and its range is R_1 . It is then thrown at an angle θ with vertical and the range is R_2 , then

A. $R_1 = 4R_2$

B. $R_1 = 2R_2$

C. $R_1 = R_2$

D. None of these

Answer: C

 [Watch Video Solution](#)

9. The range of a projectile launched at an angle of 15° with horizontal is 1.5km. The range of projectile when launched at an angle of 45° to the horizontal is

A. 1.5 km

B. 3 km

C. 6km

D. 0.75km

Answer: B



Watch Video Solution

10. A body is thrown horizontally from the top of a tower of height $5m$. It touches the ground at a distance of $10m$ from the foot of the tower. Find the initial velocity of the body.

A. $2.5ms^{-1}$

B. $5ms^{-1}$

C. $10ms^{-1}$

D. $20ms^{-1}$

Answer: C



Watch Video Solution

11. Velocity and acceleration of a particle at some instant of time are $v = (3\hat{i} + 4\hat{j})ms^{-1}$ and $a = -(6\hat{i} + 8\hat{j})ms^{-2}$ respectively. At the same instant particle is at origin. Maximum x-coordinate of particle will be

- A. 1.5 m
- B. 0.75m
- C. 2.25m
- D. 4m

Answer: B



Watch Video Solution

12. A particle moves in the XY-plane according to the law $x = kt, y = kt(1 - \alpha t)$, where k and α are positive constants and t is time. The trajectory of the particle is

A. $y = kx$

B. $y = x - \frac{\alpha x^2}{k}$

C. $y = -\frac{\alpha x^2}{k}$

D. $y = \alpha x$

Answer: B



Watch Video Solution

13. A projectile is thrown upward with a velocity v_0 at an angle α to the horizontal. The change in velocity of the projectile when it strikes the same horizontal plane is

- A. $v_0 \sin \alpha$ vertically downward
- B. $2v_0 \sin \alpha$ vertically downward
- C. $2v_0 \sin \alpha$ vertically upward
- D. zero

Answer: B



[Watch Video Solution](#)

14. The equation of trajectory of an oblique projectile

$y = \sqrt{3}x - \frac{gx^2}{2}$. The angle of projection is

A. 90°

B. zero

C. 60°

D. 30°

Answer: C



Watch Video Solution

15. The maximum range of a gun on horizontal terrain is 1km. If

$g = 10ms^{-2}$, what must be the muzzle velocity of the shell ?

A. $400ms^{-1}$

B. $200ms^{-1}$

C. $100ms^{-1}$

D. $50ms^{-1}$

Answer: C

 [Watch Video Solution](#)

16. Two paper screens A and B are separated by a distance of $100m$. A bullet pierces A and B . The hole in B is $10cm$ below the hole in A . If the bullet is travelling horizontally at the time of hitting the screen A , calculate the velocity of the bullet when it hits the screen A . Neglect resistance of paper and air.

A. $100ms^{-1}$

B. $200ms^{-1}$

C. $600ms^{-1}$

D. $700ms^{-1}$

Answer: D

 [Watch Video Solution](#)

17. A body is projected at an angle of 30° with the horizontal with momentum P . At its highest point the magnitude of the momentum is:

A. $\frac{\sqrt{3}}{2}p$

B. $\frac{2}{\sqrt{3}}p$

C. p

D. $\frac{p}{2}$

Answer: A



Watch Video Solution

18. The maximum height attained by a projectile is increased by 10% by increasing its speed of projection, without changing the

angle of projection. What will the percentage increase in the horizontal range.

A. 0.2

B. 0.15

C. 0.1

D. 0.05

Answer: C



[Watch Video Solution](#)

19. A ball is thrown up with a certain velocity at an angle θ to the horizontal. The kinetic energy KE of the ball varies with horizontal displacements as:

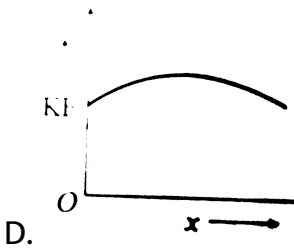
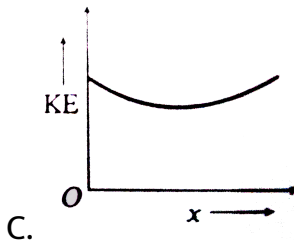
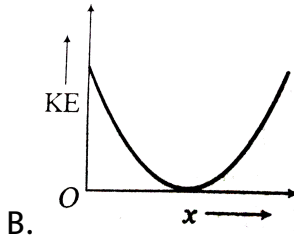
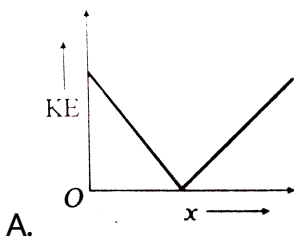

Answer: C

 Watch Video Solution

20. A ball is thrown at different angles with the same speed u and from the same points and it has same range in both the cases. If y_1 and y_2 be the heights attained in the two cases, then find the value of $y_1 + y_2$.

A. $\frac{u^2}{g}$

B. $\frac{2u^2}{g}$

C. $\frac{u^2}{2g}$

D. $\frac{u^2}{4g}$

Answer: C

 [Watch Video Solution](#)

21. A projectile is fired from level ground at an angle θ above the horizontal. The elevation angle ϕ of the highest point as seen from the launch point is related to θ by the relation.

A. $\tan \phi = \frac{1}{4} \tan \theta$

B. $\tan \phi = \tan \theta$

C. $\tan \phi = \frac{1}{2} \tan \theta$

D. $\tan \phi = 2 \tan \theta$

Answer: C

 [Watch Video Solution](#)

22. A ball is thrown up with a certain velocity at angle θ to the horizontal. The kinetic energy varies with height h of the particle as:

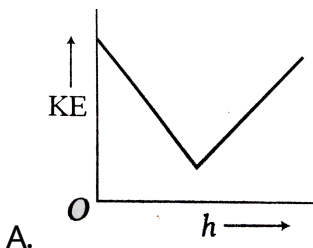

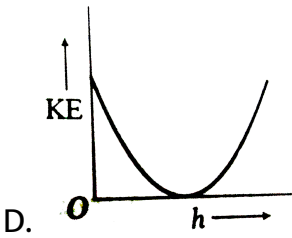
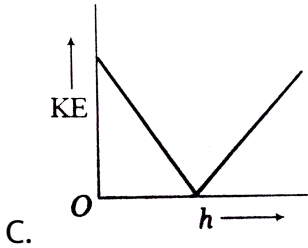
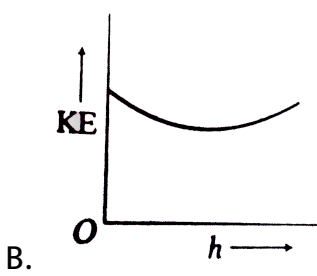

Answer: A

 [Watch Video Solution](#)

23. A body of mass m is thrown upwards at an angle θ with the horizontal with velocity v . While rising up the velocity of the mass

after t second will be

A. $\sqrt{(v \cos \theta)^2 + (v \sin \theta)^2}$

B. $\sqrt{(v \cos \theta - v \sin \theta)^2 - gt}$

C. $\sqrt{v^2 + g^2 t^2 - (2v \sin \theta)gt}$

D. $\sqrt{v^2 + g^2 t^2 - (2v \cos \theta)gt}$

Answer: C



Watch Video Solution

24. A projectile is thrown with an initial velocity of $(a\hat{i} + b\hat{j})\text{ms}^{-1}$

. If the range of the projectile is twice the maximum height reached by it, then

A. $a = 2b$

B. $b = a$

C. $b = 2a$

D. $b = 4a$

Answer: C

 [Watch Video Solution](#)

25. A projectile thrown with a speed v at an angle θ has a range R on the surface of earth. For same v and θ , its range on the surface of moon will be

A. $36R$

B. $\frac{R}{36}$

C. $\frac{R}{16}$

D. $6R$

Answer: D



Watch Video Solution

26. Three balls of same masses are projected with equal speeds at angle 15° , 45° , 75° , and their ranges are respectively R_1 , R_2 and R_3 , then

A. $R_1 > R_2 > R_3$

B. $R_1 < R_2 < R_3$

C. $R_1 = R_2 = R_3$

D. $R_1 = R_3 < R_2$

Answer: D



Watch Video Solution

27. A man can throw a stone such that it acquires maximum horizontal range 80 m. The maximum height to which it will rise for the same projectile in metre is

A. 10

B. 20

C. 40

D. 50

Answer: B



[Watch Video Solution](#)

28. The ratio of the speed of a projectile at the point of projection to the speed at the top of its trajectory is x . The angle of projection with the horizontal is

A. $\sin^{-1} x$

B. $\cos^{-1} x$

C. $\sin^{-1}(1/x)$

D. $\cos^{-1}(1/x)$

Answer: D



Watch Video Solution

29. The velocity at the maximum height of a projectile is half of its velocity of projection u . Its range on the horizontal plane is

A. $\frac{3u^2}{g}$

B. $\frac{3u^2}{2g}$

C. $\frac{u^2}{3g}$

D. $\frac{\sqrt{3}u^2}{2g}$

Answer: D



Watch Video Solution

30. A projectile is thrown from a point in a horizontal plane such that the horizontal and vertical velocities are $9.8ms^{-1}$ and $19.6ms^{-1}$. It will strike the plane after covering distance of

A. $39.2m$

B. $19.6m$

C. $9.8m$

D. $4.9m$

Answer: A



Watch Video Solution

31. A stone is projected in air. Its time of flight is 3s and range is 150m. Maximum height reached by the stone is (Take, $g = 10ms^{-2}$)

A. 37.5m

B. 22.5m

C. 90m

D. 11.25m

Answer: D

 [Watch Video Solution](#)

32. The greatest height to which a boy can throw a stone is (h). What will be the greatest distance on horizontal surface upto which the boy can throw the stone with the same speed ? Neglect the air friction.

A. $\frac{h}{2}$

B. h

C. $2h$

D. $3h$

Answer: C



Watch Video Solution

33. The range of a projectile when launched at angle θ is same as when launched at angle 2θ . What is the value of θ ?

A. 15°

B. 30°

C. 45°

D. 60°

Answer: B

 [Watch Video Solution](#)

34. A boy throws a ball with a velocity u at an angle θ with the horizontal. At the same instant he starts running with uniform velocity to catch the ball before it hits the ground. To achieve this he should run with a velocity of

A. $u \cos \theta$

B. $u \sin \theta$

C. $u \tan \theta$

D. $u \sec \theta$

Answer: A

 [Watch Video Solution](#)

35. For angles of projection of a projectile at angle $(45^\circ - \theta)$ and $(45^\circ + \theta)$, the horizontal ranges described by the projectile are in the ratio of :

A. 2:1

B. 1:2

C. 1:1

D. 2:3

Answer: C

 [Watch Video Solution](#)

36. The time of flight of a projectile is 10 s and range is 500m.

Maximum height attained by it is $[g = 10m/s^2]$

A. 125m

B. 50m

C. 100m

D. 150m

Answer: A



[Watch Video Solution](#)

37. Four bodies A,B,C and D are projected with equal velocities having angles of projection 15° , 30° , 45° and 60° with the horizontal respectively. The body having the shortest range is

A. A

B. B

C. C

D. D

Answer: A

 [Watch Video Solution](#)

38. A stone is thrown at an angle θ to the horizontal reaches a maximum height H . Then the time of flight of stone will be:

A. $\sqrt{\frac{2H}{g}}$

B. $2\sqrt{\frac{2H}{g}}$

C. $\frac{2\sqrt{2H \sin \theta}}{g}$

D. $\frac{\sqrt{2H \sin \theta}}{g}$

Answer: B

 [Watch Video Solution](#)

39. For a given velocity, a projectile has the same range R for two angles of projection. If t_1 and t_2 are the time of flight in the two cases, then $t_1 \cdot t_2$ is equal to

A. $\frac{2R}{g}$

B. $\frac{R}{g}$

C. $\frac{4R}{g}$

D. $\frac{R}{2g}$

Answer: A



[Watch Video Solution](#)

40. Two particles are projected obliquely from ground with same speed such that their range ' R ' are same but they attain

different maximum heights h_1 and h_2 then relation between

R , h_1 and h_2 is:

A. $R = \sqrt{h_1 h_2}$

B. $R = \sqrt{2h_1 h_2}$

C. $R = 2\sqrt{h_1 h_2}$

D. $R = 4\sqrt{h_1 h_2}$

Answer: D



Watch Video Solution

41. A cricket ball is hit for a six the bat at an angle of 45° to the horizontal with kinetic energy K . At the highest point, the kinetic energy of the ball is

A. zero

B. K

C. $K/2$

D. $K/\sqrt{2}$

Answer: C



Watch Video Solution

42. The equation of motion of a projectile is $y = 12x - \frac{3}{4}x^2$. The horizontal component of velocity is $3ms^{-1}$. What is the range of the projectile ?

A. 12m

B. 16m

C. 20m

D. 24m

Answer: B

 [Watch Video Solution](#)

43. A particle is thrown with a speed u at an angle θ with the horizontal. When the particle makes an angle ϕ with the horizontal. Its speed changes to v :

A. $v = u \cos \theta$

B. $v = u \cos \theta \cos \phi$

C. $v = u \cos \theta \sec \phi$

D. $v = u \sec \theta \cos \phi$

Answer: C

 [Watch Video Solution](#)

44. A particle is projected in $x - y$ plane with $y -$ axis along vertical, the point of projection being origin. The equation of projectile is $y = \sqrt{3}x - \frac{gx^2}{2}$. The angle of projectile isand initial velocity is



Watch Video Solution

45. A ball of mass m is projected from the ground with an initial velocity u making an angle of θ with the vertical. What is the change in velocity between the point of projection and the highest point ?

A. $u \cos \theta$ downward

B. $u \cos \theta$ upward

C. $u \sin \theta$ upward

D. $u \sin \theta$ downward

Answer: A

 [Watch Video Solution](#)

46. A ball is projected from ground with a speed of 20ms^{-1} at an angle of 45° with horizontal. There is a wall of 25m height at a distance of 10m from the projection point. The ball will hit the wall at a height.

- A. 5m
- B. 7.5m
- C. 10m
- D. 12.5m

Answer: B

 [Watch Video Solution](#)

47. A particle (A) is dropped from a height and another particles (B) is thrown into horizontal direction with speed of 5m/s sec from the same height. The correct statement is

- A. both particles will reach at ground simultaneously
- B. both particles will reach at ground with same speed
- C. particle (A) will reach at ground first with respect to particle (B)
- D. particle (B) will reach at ground first with respect to particle (A)

Answer: A

 [Watch Video Solution](#)

48. A bullet is to be fired with a speed of 2000m/s to hit a target 200m away on a level ground. If $g = 10\text{m/s}^2$, the gun should be aimed

- A. directly at the target
- B. 5 cm below the target
- C. 5 cm above the target
- D. 2 cm above the target

Answer: C



[Watch Video Solution](#)

49. An aeroplane moving horizontally with a speed of 720km/h drops a food packet, while flying at a height of 396.9m . the time

taken by a food pocket to reach the ground and its horizontal range is (Take $g = 9.8m / \text{sec}$)

- A. 3s and 2000m
- B. 5s and 500 m
- C. 8s and 1500m
- D. 9s and 1800 m

Answer: D



[Watch Video Solution](#)

50. A boy can throw a stone up to a maximum height of $10m$. The maximum horizontal distance that the boy can throw the same stone up to will be :

- A. $20\sqrt{2}m$

B. 10m

C. $10\sqrt{2}m$

D. 20m

Answer: D



Watch Video Solution

51. At the height 80 m , an aeroplane is moving with $150m/s$. A bomb is dropped from it so as to hit a target. At what distance from the target should the bomb be dropped (given $g = 10m/s$)

A. 605.3 m

B. 600 m

C. 80m

D. 230 m

Answer: A

 [Watch Video Solution](#)

52. A particle moves along a parabolic path $y = -9x^2$ in such a way that the x component of velocity remains constant and has a value $\frac{1}{3}m/s$. Find the instantaneous acceleration of the projectile (in m/s^2)

A. $\frac{1}{3}ms^{-2}$

B. $3ms^{-2}$

C. $\frac{2}{3}ms^{-2}$

D. $2ms^{-2}$

Answer: D

 [Watch Video Solution](#)

53. The maximum range of a projectile is 500m. If the particle is thrown up a plane, which is inclined at an angle of 30° with the same speed, the distance covered by it along the inclined plane will be

- A. 250m
- B. 500m
- C. 750m
- D. 1000m

Answer: B



Watch Video Solution

54. A ball is thrown from a point O aiming a target at angle 30° with the horizontal so that the ball hits the target at B but the

ball hits at point A, a vertical distance h below B. If the initial velocity of the ball is 20ms^{-1} and the horizontal distance between O and C is 10 m. Find the value of h .

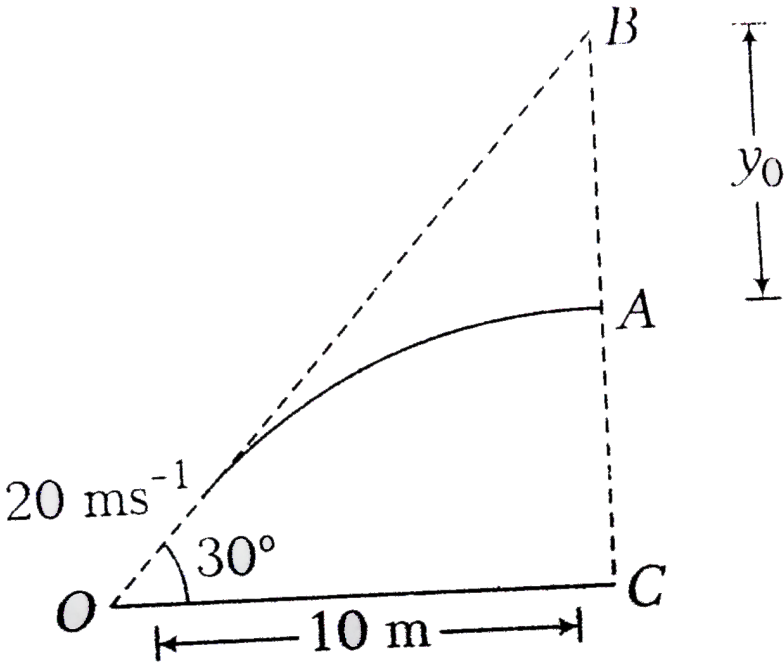

- A. $\frac{g}{6}m$
- B. $\frac{g}{10}m$
- C. $\frac{g}{3}m$
- D. $\frac{g}{12}m$

Answer: A

 [Watch Video Solution](#)

55. The range of a projectile fired at an angle of 15° is 50 m. If it is fired with the same speed at an angle of 45° its range will be

- A. 60m
- B. 71m
- C. 100m
- D. 141m

Answer: C

 [Watch Video Solution](#)

56. A cricket fielder can throw the cricket ball with a speed v_0 . If he throws the ball while running with speed u at an angle θ to the horizontal.

The effective angle to the horizontal at which the ball is projected in air as seen by a spectator is

A. $\tan^{-1} \left[\frac{v_0 \cos \theta}{u + v_0 \sin \theta} \right]$

B. $\tan^{-1} \left[\frac{v_0 \sin \theta}{u + v_0 \cos \theta} \right]$

C. $\tan^{-1} \left[\frac{u}{v_0 \cos \theta + v_0 \sin \theta} \right]$

D. $\tan^{-1} \left[\frac{v_0 \sin \theta + v_0 \cos \theta}{u} \right]$

Answer: B



Watch Video Solution

57. Two stones are projected so as to reach the same distance from the point of projection on a horizontal surface. The maximum height reached by one exceeds the other by an amount equal to half the sum of the height attained by them. Then angle of projection of the stone which attains smaller height is

A. 45°

B. 60°

C. 30°

D. $\tan^{-1}(3/4)$

Answer: C



Watch Video Solution

58. A projectile A is thrown at an angle 30° to the horizontal from point P. At the same time, another projectile B is thrown with velocity v_2 upwards from the point Q vertically below the highest point A would reach. For B to collide with A the ratio $\frac{v_2}{v_1}$ should be

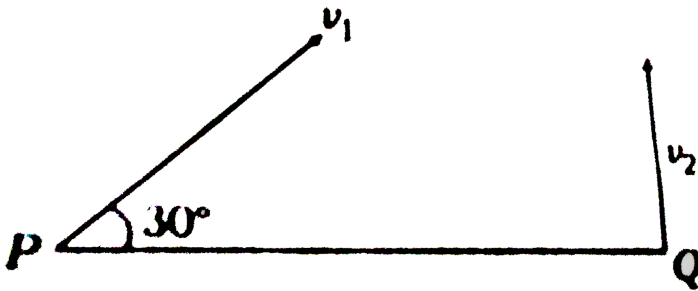

A. $\frac{\sqrt{3}}{2}$

B. 2

C. $\frac{1}{2}$

D. $\frac{2}{\sqrt{3}}$

Answer: C



59. The equations of motion of a projectile are given by $x = 36tm$ and $2y = 96t - 9.8t^2m$. The angle of projection is

A. $\sin^{-1}\left(\frac{4}{5}\right)$

B. $\sin^{-1}\left(\frac{3}{5}\right)$

C. $\sin^{-1}\left(\frac{4}{5}\right)$

D. $\sin^{-1}\left(\frac{3}{4}\right)$

Answer: C

 [Watch Video Solution](#)

60. A ball is thrown from a point with a speed ' $v^{\wedge}(0)$ ' at an elevation angle of θ . From the same point and at the same instant, a person starts running with a constant speed $\frac{v_0}{2}$ to

catch the ball . Will the person be able to catch the ball ? If yes, what should be the angle of projection θ ?

A. Yes, 60°

B. Yes, 30°

C. No

D. Yes, 45°

Answer: A



[Watch Video Solution](#)

61. An arrow is shot into air. Its range is 200m and its time of flight is 5s. If $g = 10ms^{-2}$, then horizontal component of velocity and the maximum height will be respectively

A. $20ms^{-1}$, 62.50m

B. 40m.s^{-1} , 31.25m

C. 80m.s^{-1} , 62.5m

D. None of these

Answer: B



Watch Video Solution

62. A particle of mass 2kg moves with an initial velocity of $\vec{v} = 4\hat{i} + 4\hat{j}\text{m.s}^{-1}$. A constant force of $\vec{F} = 20\hat{j}\text{N}$ is applied on the particle. Initially, the particle was at $(0,0)$. The x-coordinates of the particle when its y-coordinates again becomes zero is given by

A. 3.2m

B. 6m

C. 4.8m

D. 1.2m

Answer: A

 [Watch Video Solution](#)

63. Two balls are thrown simultaneously from ground with same velocity of $10ms^{-1}$ but different angles of projection with horizontally. Both balls fall at same distance $5\sqrt{3}m$ from point of projection. What is the time interval between balls striking the ground ?

A. $(\sqrt{3} - 1)s$

B. $(\sqrt{3} + 1)s$

C. $\sqrt{3}s$

D. 1s

Answer: A

 [Watch Video Solution](#)

64. A piece of marble is projected from earth's surface with velocity of $19.6\sqrt{2}ms^{-1}$ at 45° . 2 s later its velocity makes an angle α with horizontal, where α is

A. 45°

B. 30°

C. 60°

D. 0°

Answer: D

 [Watch Video Solution](#)

65. An object of mass m is projected with a momentum p at such an angle that its maximum height is $1/4$ th of its horizontal range. Its minimum kinetic energy in its path will be

A. $\frac{p^2}{8m}$

B. $\frac{p^2}{4m}$

C. $\frac{3p^2}{4m}$

D. $\frac{p^2}{m}$

Answer: B



[Watch Video Solution](#)

66. A particle is projected with a velocity of $30ms^{-1}$, at an angle of $\theta_0 = \tan^{-1}\left(\frac{3}{4}\right)$. After 1s, the particle is moving at an angle θ

to the horizontal, where $\tan \theta$ will be equal to (Take, $g = 10\text{ms}^{-2}$)

A. 1

B. 2

C. $\frac{1}{2}$

D. $\frac{1}{3}$

Answer: D



[Watch Video Solution](#)

67. A body is projected from the ground with a velocity $v = (3\hat{i} + 10\hat{j})\text{ms}^{-1}$. The maximum height attained and the range of the body respectively are (given $g = 10\text{ms}^{-2}$)

A. 5 m and 6m

B. 3m and 10m

C. 6m and 5m

D. 3m and 5m

Answer: A



Watch Video Solution

68. A bomber moving horizontally with $500m/s$ drops a bomb which strikes ground in 10s. The angle of strike with horizontal is

A. $\tan^{-1}\left(\frac{1}{5}\right)$

B. $\tan^{-1}\left(\frac{1}{2}\right)$

C. $\tan^{-1}(1)$

D. $\tan^{-1}(5)$

Answer: A

 [Watch Video Solution](#)

69. A ball rolls off the edge of a horizontal table top 4 m high. If it strikes the floor at a point 5 m horizontally away from the edge of the table, what was its speed at the instant it left the table?

A. $2.5ms^{-1}$

B. $3.5ms^{-1}$

C. $5.5ms^{-1}$

D. $6.5ms^{-1}$

Answer: C

 [Watch Video Solution](#)

70. A ball is projected upwards from the top of a tower with a velocity 50ms^{-1} making an angle 30° with the horizontal. The height of tower is 70m. After how many seconds from the instant of throwing, will the ball reach the ground. ($g = 10\text{ms}^{-2}$)

A. 2s

B. 5s

C. 7s

D. 9s

Answer: C

 [Watch Video Solution](#)

71. From the top of tower of height 40 m a ball is projected upwards with a speed of 20 m/sec at an angle of elevation of 30° . Then the ration of the total time taken by the ball to hit the

ground to its time of flight (time taken to come back to the same elevation) is (take $g = 10m/sec^2$)

A. 2: 1

B. 3: 1

C. 3: 2

D. 1: 5: 1

Answer: A



[Watch Video Solution](#)

72. The coordinates of a moving particle at any time t are given by

$x = ct$ and $y = bt^2$. The speed of the particle is given by

A. $2t\sqrt{b^2 - c^2}$

B. $\sqrt{4b^2t^2 + c^2}$

C. $2t(b + c)$

D. $2t(b - c)$

Answer: B

 [Watch Video Solution](#)

73. Two particles A and B are projected simultaneously from a fixed point of the ground. Particle A is projected on a smooth horizontal surface with speed v , while particle B is projected in air with speed v , while particle B is projected in air with speed $\frac{2v}{\sqrt{3}}$. If particle B hits the particle A, the angle of projection of B with the vertical is

A. 30°

B. 60°

C. Both (a) and (b)

D. 45°

Answer: A



Watch Video Solution

74. An object is projected with a velocity of $20\frac{m}{s}$ making an angle of 45° with horizontal. The equation for the trajectory is $h = Ax - Bx^2$ where h is height, x is horizontal distance, A and B are constants. The ratio A:B is ($g = ms^{-2}$)

A. 1:5

B. 5:1

C. 1:40

D. 40:1

Answer: D



Watch Video Solution

75. A particle is projected from horizontal making an angle of 53° with initial velocity 100ms^{-1} . The time taken by the particle to make angle 45° from horizontal is

A. 14s

B. 2s

C. Both (a) and (b)

D. None of these

Answer: C



Watch Video Solution

76. Let A, B and C be points in a vertical line at height h , $\frac{4h}{5}$ and $\frac{h}{5}$ and from the ground. A particle released from rest from the point A reaches the ground in time T . The time taken by the particle to go from B to C is T_{BC} . Then $\frac{T}{(T_{BC})^2} =$

A. $\frac{gT^2}{6}$

B. $\frac{gT^2}{12}$

C. $\frac{gT^2}{18}$

D. $\frac{gT^2}{24}$

Answer: D



Watch Video Solution

77. A particle is projected from a horizontal plane ($x - z$ plane) such that its velocity vector at time t is given by

$\vec{V} = a\hat{i} + (b - ct)\hat{j}$. Its range on the horizontal plane is given by

A. $2ab/c$

B. ab/c

C. ac/b

D. $a/2bc$

Answer: A

 [Watch Video Solution](#)

78. A ball is thrown from the ground to clear a wall 3 m high at a distance of 6 m and falls 18 m away from the wall. Find the angle of projection of ball.

A. $\tan^{-1}\left(\frac{3}{2}\right)$

B. $\tan^{-1}\left(\frac{2}{3}\right)$

C. $\tan^{-1}\left(\frac{1}{2}\right)$

D. $\tan^{-1}\left(\frac{3}{4}\right)$

Answer: B

 [Watch Video Solution](#)

79. The horizontal range and maximum height attained by a projectile are R and H , respectively. If a constant horizontal acceleration $a = g/4$ is imparted to the projectile due to wind, then its horizontal range and maximum height will be

A. $(R + H), \frac{H}{2}$

B. $\left(R + \frac{H}{2}\right), 2H$

C. $(R + 2H), H$

D. $(R + H), H$

Answer: D

 [Watch Video Solution](#)

80. A large number of bullets are fired in all directions with the same speed v . Find the maximum area on the ground on which these bullets will spread.

A. $\pi \frac{v^2}{g}$

B. $\pi \frac{v^4}{g^2}$

C. $\pi^2 \frac{v^2}{g^2}$

D. $\pi^2 \frac{v^2}{g^2}$

Answer: B

 [Watch Video Solution](#)

81. A cart is moving horizontally along a straight line with constant speed $30ms^{-1}$. A particle is to be fired vertically upwards from the moving cart in such a way that it returns to the cart at the same point from where it was projected after the cart has moved $80m$. At what speed (relative to the cart) must the projectile be fired? (Take $g = 10ms^{-2}$)

A. $10ms^{-1}$

B. $\frac{20}{3}ms^{-1}$

C. $\frac{40}{3}ms^{-1}$

D. $\frac{80}{3}ms^{-1}$

Answer: C



Watch Video Solution

82. A particle is projected from the ground at an angle 30° with the horizontal with an initial speed 20ms^{-1} . After how much time will the velocity vector of projectile be perpendicular to the initial velocity ? [in second].

A. $u / g \sin \theta$

B. $u / g \cos \theta$

C. $2u / g \sin \theta$

D. $2u \tan \theta$

Answer: A



[Watch Video Solution](#)

83. Two particles are simultaneously projected in opposite directions horizontally from a given point in space where gravity g

is uniform. If u_1 and u_2 be their initial speeds, then the time t after which their velocities are mutually perpendicular is given by

A. $\frac{\sqrt{u_1 u_2}}{g}$

B. $\frac{\sqrt{u_1^2 + u_2^2}}{g}$

C. $\frac{\sqrt{u_1(u_1 + u_2)}}{g}$

D. $\frac{\sqrt{u_2(u_1 + u_2)}}{g}$

Answer: A



Watch Video Solution

84. A hill is $500m$ high. Supplies are to be sent across the hill using a canon that can hurl packets at a speed of $125m/s$ over the hill. The canon is located at a distance of $800m$ from the foot to hill and can be moved on the ground at a speed of $2m/s$, so

that its distance from the hill can be adjusted. What is the shortest time in which a packet can reach on the ground across the hill ? Take $g = 10m/s^2$.

A. 10s

B. 25s

C. 35s

D. 45s

Answer: D



[Watch Video Solution](#)

85. A ball is rolled off the edge of a horizontal table at a speed of $4m/second$. It hits the ground after 0.4 second . Which statement given below is true

- A. It hits the ground at a horizontal distance 1.6 m from the edge of the table
- B. The speed with which it hits the ground is $4.0ms^{-1}$
- C. Height of the table 1m
- D. It hits the ground at an angle of 60° to the horizontal

Answer: A

 [Watch Video Solution](#)

86. A jet aeroplane is flying at a constant height of 2 km with a speed $360kmh^{-1}$ above the ground towards a target and releases a bomb. After how much time it will hit the target and what will be the horizontal distance of the aeroplane from the target so that the bomb should hit the target ? (Take $g = 10ms^{-2}$)

- A. 10s, 1km
- B. 20 s, 2km
- C. 30s, 3km
- D. 40s, 4km

Answer: B

 [Watch Video Solution](#)

87. Two seconds after projection, a projectile is travelling in a direction inclined at 30° to the horizontal. After one more second, it is travelling horizontally. Find the magnitude and direction of its velocity.

- A. the velocity of projection is $20\sqrt{3}ms^{-1}$
- B. the angle of projection is 30° with horizontal

C. Both (a) and (b) are correct

D. Both (a) and (b) are wrong

Answer: C

 [Watch Video Solution](#)

88. A projectile is fired at an angle of 30° to the horizontal such that the vertical component of its initial velocity is 80m/s . Its time of flight is T . Its velocity at $t = T/4$ has a magnitude of nearly.

A. 200m/s^{-1}

B. 300m/s^{-1}

C. 100m/s^{-1}

D. None of these

Answer: D

 [Watch Video Solution](#)

89. A very broad elevator is going up vertically with constant acceleration of 2 m/s^2 . At the instant when its velocity is 4 m/s a ball is projected from the floor of the lift with a speed of 4 m/s relative to the floor at an elevation of 30° . The range of ball over the floor of the lift is :

A. $\frac{1}{2} \text{ s}$

B. $\frac{1}{3} \text{ s}$

C. $\frac{1}{4} \text{ s}$

D. 1 s

Answer: B

 [Watch Video Solution](#)

90. The velocity of a projectile when it is at the greatest height is $\left(\sqrt{2/5}\right)$ times its velocity when it is at half of its greatest height. Determine its angle of projection.

- A. 30°
- B. 45°
- C. 60°
- D. 37°

Answer: C

 Watch Video Solution

91. A body of mass 1kg is projected with velocity 50m.s^{-1} at an angle of 30° with the horizontal. At the highest point of its path a

force 10 N starts acting on body for 5s vertically upward besides gravitational force, what is horizontal range of the body (Take, $g = 10ms^{-2}$)

- A. $125\sqrt{3}$
- B. $200\sqrt{3}m$
- C. $500m$
- D. $250\sqrt{3}m$

Answer: D

 [Watch Video Solution](#)

92. A grasshopper can jump a maximum distance of $1.6m$. It spends negligible time on the ground. How far can it go in $10s$?

- A. $5\sqrt{2}m$

B. $10\sqrt{2}m$

C. $20\sqrt{2}m$

D. $40\sqrt{2}m$

Answer: C



Watch Video Solution

93. A ball rolls off the top of a staircase with a horizontal velocity um/s . If the steps are h meter high and b meter wide, the ball will hit the edge of the n th steps, if:

A. $\frac{hu^2}{gb^2}$

B. $\frac{u^2g}{gb^2}$

C. $\frac{2hu^2}{gb^2}$

D. $\frac{2u^2g}{hb^2}$

Answer: C

 Watch Video Solution

94. In the given figure for a projectile

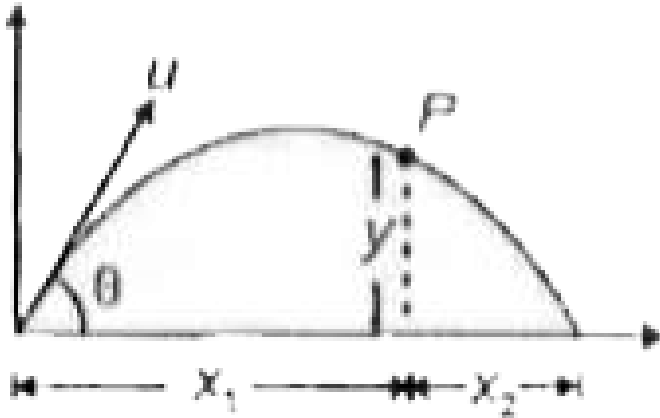

A. $\tan^{-1}\left(\frac{1}{\sqrt{3}}\right)$

B. $\tan^{-1}\sqrt{3}$

C. $\tan^{-1}\left(\frac{2}{\sqrt{3}}\right)$

D. $\tan^{-1}\left(\frac{\sqrt{3}}{2}\right)$

Answer: C

 **Watch Video Solution**

95. Two particles projected from the same point with same speed u at angles of projection α and β strike the horizontal ground at the same point. If h_1 and h_2 are the maximum heights attained by the projectile, R is the range for both and t_1 and t_2 are their times of flights, respectively, then incorrect option is :

A. $\alpha + \beta = \frac{\pi}{2}$

B. $R = 4\sqrt{h_1 h_2}$

C. $\tan \alpha = \frac{t_1}{t_2} = \sqrt{h_1 h_2}$

D. None of the above

Answer: C

 **Watch Video Solution**

96. Balls A and B are thrown from two points lying on the same horizontal plane separated by a distance 120 m. which of the following statement (s) is/are correct ?

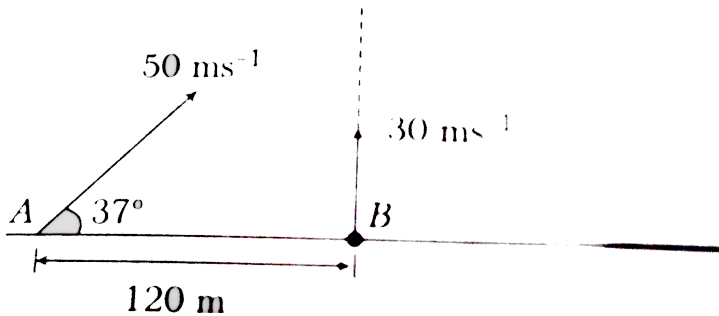

- A. The two balls can never meet
- B. The balls can meet if the ball B is thrown 1s later
- C. The two balls meet at a height of 45 m
- D. None of the above

Answer: C



B. Medical entrance

1. Assertion In projectile motion, if time of flight is made two times, then maximum height will become four times.

Reason $T \propto \sin \theta$ and $H \propto \sin^2 \theta$, where θ is angle of projection.

- A. If both Assertion and Reason are correct and Reason is the correct explanation of Assertion
- B. If both Assertion and Reason are correct but Reason is not the correct explanation of Assertion
- C. If Assertion is true but Reason is false
- D. If Assertion is false but Reason is true

Answer: A



Watch Video Solution

Medical entrance

1. Assertion If in a projectile motion, we take air friction into consideration, then $t_{\text{ascent}} < t_{\text{descent}}$.

Reason During ascent, magnitude of retardation is greater than magnitude of acceleration during descent.

- A. If both Assertion and Reason are correct and Reason is the correct explanation of Assertion
- B. If both Assertion and Reason are correct but Reason is not the correct explanation of Assertion
- C. If Assertion is true but Reason is false
- D. If Assertion is false but Reason is true

Answer: A



Watch Video Solution

2. Assertion In case of projectile motion, the magnitude of rate of change of velocity is variable.

Reason In projectile motion, magnitude of velocity first decreases and then increases during the motion.

- A. If both Assertion and Reason are correct and Reason is the correct explanation of Assertion
- B. If both Assertion and Reason are correct but Reason is not the correct explanation of Assertion
- C. If Assertion is true but Reason is false
- D. If Assertion is false but Reason is true

Answer: D



Watch Video Solution

3. Assertion At highest point of a projectile, dot product of velocity and acceleration is zero.

Reason At highest point, velocity and acceleration are mutually perpendicular.

- A. If both Assertion and Reason are correct and Reason is the correct explanation of Assertion
- B. If both Assertion and Reason are correct but Reason is not the correct explanation of Assertion
- C. If Assertion is true but Reason is false
- D. If Assertion is false but Reason is true

Answer: A



Watch Video Solution

4. Assertion A particle is projected with speed u at an angle θ with the horizontal. At any time during motion, speed of particle is v at angle α with the vertical, then $v \sin \alpha$ is always constant throughout the motion.

Reason In case of projectile motion, magnitude of radical acceleration at topmost point is maximum.

- A. If both Assertion and Reason are correct and Reason is the correct explanation of Assertion
- B. If both Assertion and Reason are correct but Reason is not the correct explanation of Assertion
- C. If Assertion is true but Reason is false
- D. If Assertion is false but Reason is true

Answer: B



Watch Video Solution

5. Assertion In projectile motion, if time of flight is 4s, then maximum height will be 20 m. (Take, $g = 10ms^{-2}$)

Reason Maximum height = $\frac{gT}{2}$.

- A. If both Assertion and Reason are correct and Reason is the correct explanation of Assertion
- B. If both Assertion and Reason are correct but Reason is not the correct explanation of Assertion
- C. If Assertion is true but Reason is false
- D. If Assertion is false but Reason is true

Answer: C



Watch Video Solution

6. Assertion: For projection angle $\tan^{-1}(4)$, the horizontal range and the maximum height of a projectile are equal.

Reason: The maximum range of projectile is directly proportional to square of velocity and inversely proportional to acceleration due to gravity.

- A. If both Assertion and Reason are correct and Reason is the correct explanation of Assertion
- B. If both Assertion and Reason are correct but Reason is not the correct explanation of Assertion
- C. If Assertion is true but Reason is false
- D. If Assertion is false but Reason is true

Answer: B

 [Watch Video Solution](#)

7. A particle is acted simultaneously by mutually perpendicular simple harmonic motion $x = a \cos \omega t$ and $y = a \sin \omega t$. The trajectory of motion of the particle will be

- A. If both Assertion and Reason are correct and Reason is the correct explanation of Assertion
- B. If both Assertion and Reason are correct but Reason is not the correct explanation of Assertion
- C. If Assertion is true but Reason is false
- D. If Assertion is false but Reason is true

Answer: D



Watch Video Solution

8. Assertion If a particle is projected vertically upwards with velocity u , the maximum height attained by the particle is h_1 . The same particle is projected at angle 30° from horizontal with the same speed u . Now the maximum height is h_2 . Thus $h_1 = 4h_2$.

Reason In first case, $v = 0$ at highest point and in second case $v \neq 0$ at highest point.

- A. If both Assertion and Reason are correct and Reason is the correct explanation of Assertion
- B. If both Assertion and Reason are correct but Reason is not the correct explanation of Assertion
- C. If Assertion is true but Reason is false
- D. If Assertion is false but Reason is true

Answer: B



Watch Video Solution

9. Assertion On the surface of moon, value of g is $\frac{1}{6}$ th the value on the surface of earth. A particle is projected as projectile under similar condition on the surface of moon and on the surface of earth. Then values of T, H and R on the surface of moon will become six times.

Reason T, H and $R \propto \frac{1}{g}$

- A. If both Assertion and Reason are correct and Reason is the correct explanation of Assertion
- B. If both Assertion and Reason are correct but Reason is not the correct explanation of Assertion
- C. If Assertion is true but Reason is false
- D. If Assertion is false but Reason is true

Answer: A



Watch Video Solution

10. Assertion In projectile motion, the angle between instantaneous velocity vector and acceleration vector can be anything between 0 to π (excluding the limiting case)

Reason In projectile motion, acceleration vector is always pointing vertically downwards. (Neglect air friction.)

- A. If both Assertion and Reason are correct and Reason is the correct explanation of Assertion
- B. If both Assertion and Reason are correct but Reason is not the correct explanation of Assertion
- C. If Assertion is true but Reason is false
- D. If Assertion is false but Reason is true

Answer: A



Watch Video Solution

11. Assertion Particle-1 is dropped from a tower and particle-2 is projected horizontal from the same tower. Then both the particles reach the ground simultaneously.

Reason Both are particles strike the ground with different speeds.

- A. If both Assertion and Reason are correct and Reason is the correct explanation of Assertion
- B. If both Assertion and Reason are correct but Reason is not the correct explanation of Assertion
- C. If Assertion is true but Reason is false
- D. If Assertion is false but Reason is true

Answer: B



Watch Video Solution

12. Assertion At height 20 m from ground , velocity of a projectile is $v = (20\hat{i} + 10\hat{j})ms^{-1}$. Here, \hat{i} is horizontal and \hat{j} is vertical. Then, the particle is at the same height after 4s.

Reason Maximum height of particle from ground is 40m (take, $g = 10ms^{-2}$)

- A. If both Asseration and Reason are correct and Reason is the correct explanation of Assertion
- B. If both Assertion and Reason are correct but Reason is not the correct explanation of Assertion
- C. If Assertion is true but Reason is false
- D. If Assertion is false but Reason is true

Answer: B



Watch Video Solution

Match the Columns

1. A particle is projected from ground with velocity u at an angle θ from horizontal. Match the following two columns.

Column I	Column II
(A) Average velocity between initial and final points	(p) $u \sin \theta$
(B) Change in velocity between initial and final points	(q) $u \cos \theta$
(C) Change in velocity between initial and peak points	(r) zero
(D) Average velocity between initial and highest points	(s) None



Watch Video Solution

2. Given that $u_x =$ horizontal component of initial velocity of a projectile, $u_y =$ vertical component of initial velocity, $R =$

horizontal range, T = time of flight and H = maximum height of projectile. Now match the following two columns.

Column I	Column II
(A) u_x is doubled, u_y is halved	(p) H will remain unchanged
(B) u_y is doubled u_x is halved	(q) R will remain unchanged
(C) u_x and u_y both are doubled	(r) R will become four times
(D) Only u_y is doubled	(s) H will become four times



[Watch Video Solution](#)

3. A particle is projected horizontally from a tower with velocity $10ms^{-1}$. Taking $g = 10ms^{-2}$. Match the following two columns at time $t = 1s$.

Column I	Column II
(A) Horizontal component of velocity	(p) 5 SI units
(B) Vertical component of velocity	(q) 10 SI unit
(C) Horizontal displacement	(r) 15 SI unit
(D) Vertical displacement	(s) 20 SI unit



[Watch Video Solution](#)

4. Trajectory of particle in a projectile motion is given as

$$y = x - \frac{x^2}{80}. \text{ Here } x \text{ and } y \text{ are in metre. For this projectile motion}$$

match the following with $g = 10ms^{-2}$.

Column I	Column II
(A) Angle of projection	(p) 20 m
(B) Angle of velocity with horizontal after 4 s	(q) 80 m
(C) Maximum height	(r) 45°
(D) Horizontal range	(s) $\tan^{-1}\left(\frac{1}{2}\right)$



[Watch Video Solution](#)

C. Medical entrances gallery

1. A particle moves so that its position vector is given by

$$\vec{r} = \cos \omega t \hat{x} + \sin \omega t \hat{y}, \text{ where } \omega \text{ is a constant which of the}$$

following is true ?

- A. Velocity and acceleration both are parallel to r
- B. velocity is perpendicular to r and acceleration is directed towards to origin
- C. Velocity is perpendicular to r and acceleration is directed away from the origin
- D. Velocity and acceleration both are perpendicular to r

Answer: B

 [Watch Video Solution](#)

Medical entrances gallery

1. Two inclined planes OA and OB intersect in a horizontal plane having their inclinations α and β with the horizontal as shown in figure. A particle is projected from P with velocity u along a

direction perpendicular to plane OA. The particle strikes plane OB perpendicularly at Q.

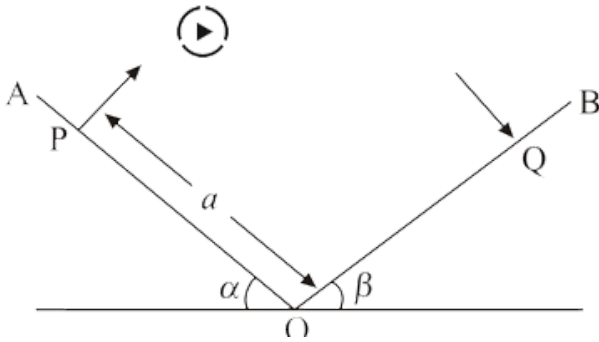

If $\alpha = 30^\circ$, $\beta = 30^\circ$ the time of flight from P to Q is

- A. $\tan^{-1} \left[\frac{P^2 + PQ + Q^2}{PQ} \right]$
- B. $\tan^{-1} \left[\frac{P^2 + Q^2 - PQ}{PQ} \right]$
- C. $\tan^{-1} \left[\frac{P^2 + Q^2}{2PQ} \right]$
- D. $\sin^{-1} \left[\frac{P^2 + Q^2 + PQ}{2PQ} \right]$

Answer: A

 [Watch Video Solution](#)

2. A ball is thrown from the top of a tower with an initial velocity of 10 m/s at an angle of 30° above the horizontal. It hits the ground at a distance of 17.3 m from the base of the tower. The height of the tower ($g = 10\text{ m/s}^2$) will be

A. $\frac{50}{\sqrt{3}} \left[1 - \frac{10}{\sqrt{3}} \right] m$

B. $\frac{50}{3} \left[1 - \frac{10}{\sqrt{3}} \right] m$

C. $\frac{100}{\sqrt{3}} \left[1 - \frac{10}{\sqrt{3}} \right] m$

D. $\frac{100}{3} \left[1 - \frac{10}{\sqrt{3}} \right] m$

Answer: A



Watch Video Solution

3. The range of a projectile is R when the angle of projection is 40° . For the same velocity of projection and range, the other

possible angle of projection is

A. 45°

B. 50°

C. 60°

D. 40°

Answer: B



[Watch Video Solution](#)

4. A particle with a velocity (u) so that its horizontal range is twice the greatest height attained. Find the horizontal range of it.

A. $\frac{4v^2}{5g}$

B. $\frac{v^2}{g}$

C. $\frac{v^2}{2g}$

D. $\frac{2v^2}{3g}$

Answer: A



[Watch Video Solution](#)

5. If the angle of projection of a projector with same initial velocity exceed or fall short of 45° by equal amount α , then the ratio of horizontal ranges is

A. 1 : 2

B. 1 : 3

C. 1 : 4

D. 1 : 1

Answer: D



[Watch Video Solution](#)

6. A particle is moving such that its position coordinates (x, y) are $(2m, 3m)$ at time $t = 0$, $(6m, 7m)$ at time $t = 2s$, and $(13m, 14m)$ at time $t = 5s$.

Average velocity vector $\left(\vec{V}_{av}\right)$ from $t = 0$ to $t = 5s$ is

A. $\frac{1}{5} (13\hat{i} + 14\hat{j})$

B. $\frac{7}{3} (\hat{i} + \hat{j})$

C. $2(\hat{i} - \hat{j})$

D. $\frac{11}{5} (\hat{i} + \hat{j})$

Answer: D

 [Watch Video Solution](#)

7. A cricket ball thrown across a field is a heights h_1 and h_2 from the point of projection at time t_1 and t_2 respectively after the throw. The ball is caught by a fielder at the same height as that of projection. The time of flight of the ball in this journey is

A. $\left(\frac{h_1 t_2^2 - h_2 t_1^2}{h_1 t_2 - h_2 t_1} \right)$

B. $\left(\frac{h_1 t_2^2 - h_2 t_1^2}{h_1 t_2 + h_2 t_1} \right)$

C. $\left(\frac{h_1 t_2^2 - h_2 t_1^2}{h_1 t_2 - h_2 t_1} \right)$

D. None of these

Answer: C



Watch Video Solution

8. For an object thrown at 45° to the horizontal, the maximum height H and horizontal range R are related as

A. $R = 16H$

B. $R = 8H$

C. $R = 4H$

D. $R = 2H$

Answer: C

 [Watch Video Solution](#)

9. A body is projected horizontally from the top of a tower with a velocity of 10 m/s . If it hits the ground at an angle 45° , then vertical component of velocity when it hits ground in m/s is

A. $10\sqrt{2}$

B. $5\sqrt{2}$

C. 5

D. 10

Answer: D



[Watch Video Solution](#)

10. A body is projected with an angle θ . The maximum height reached is h . If the time of flight is 4 sec and $g = 10 \text{ m/s}^2$, then the value of h is

A. 40 m

B. 20 m

C. 5 m

D. 10 m

Answer: B



[Watch Video Solution](#)

11. The velocity of a projectile at the initial point A is $(2\hat{i} + 3\hat{j})\text{ms}^{-1}$. Its velocity (in ms^{-1}) at point B is

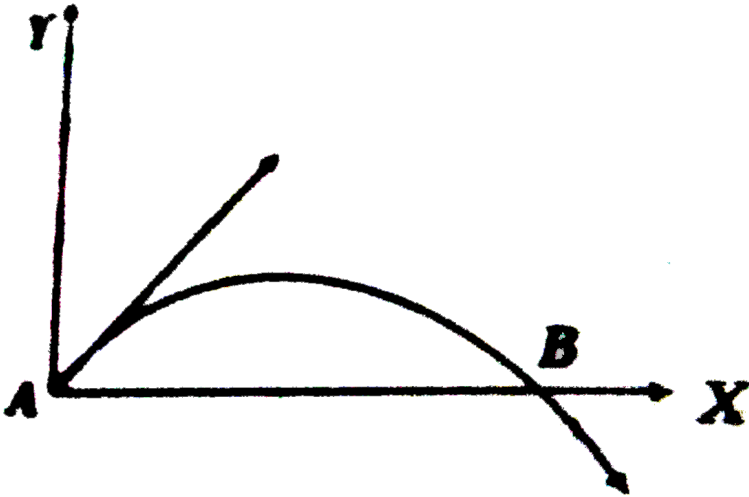

- A. $2\hat{i} - 3\hat{j}$
- B. $-2\hat{i} + 3\hat{j}$
- C. $2\hat{i} - 3\hat{j}$
- D. $2\hat{i} + 3\hat{j}$

Answer: C



Watch Video Solution

12. A projectile is thrown with initial velocity u_0 and angle 30° with the horizontal. If it remains in the air for 1s. What was its initial velocity ?

A. $19.6ms^{-1}$

B. $9.8ms^{-1}$

C. $4.9ms^{-1}$

D. $1ms^{-1}$

Answer: B



Watch Video Solution

13. A projectile is projected at 10ms^{-1} by making an angle 60° to the horizontal. After sometime, its velocity makes an angle of 30° to the horizontal . Its speed at this instant is:

A. $\frac{10}{\sqrt{3}}$

B. $10\sqrt{3}$

C. $\frac{5}{\sqrt{3}}$

D. $5\sqrt{3}$

Answer: A



[Watch Video Solution](#)

14. There are two angles of projection for which the horizontal range is the same. Show that the sum of the maximum heights for these two angles is independent of the angle of projection.

A. $\tan^2 \theta_1$

B. $v_0^2 \sin^2 \theta_1$

C. $v_0 \sin \theta_1$

D. $v_0 / \cos \theta_1$

Answer: A



Watch Video Solution

15. The velocity vector of the motion described by the position vector of a particle, $r = 2t\hat{i} + t^2\hat{j}$ is given by

A. $v = 2\hat{i} + 2t\hat{j}$

B. $v = 2t\hat{i} + 2t\hat{j}$

C. $v = t\hat{i} + t^2\hat{j}$

D. $v = 2\hat{i} + t^2\hat{j}$

Answer: A

 Watch Video Solution

16. Two stones are projected from level ground. Trajectory of two stones are shown in figure. Both stones have same maximum heights above level ground as shown. Let T_1 and T_2 be their time of flights and u_1 and u_2 be their speeds of projection respectively (neglect air resistance). then

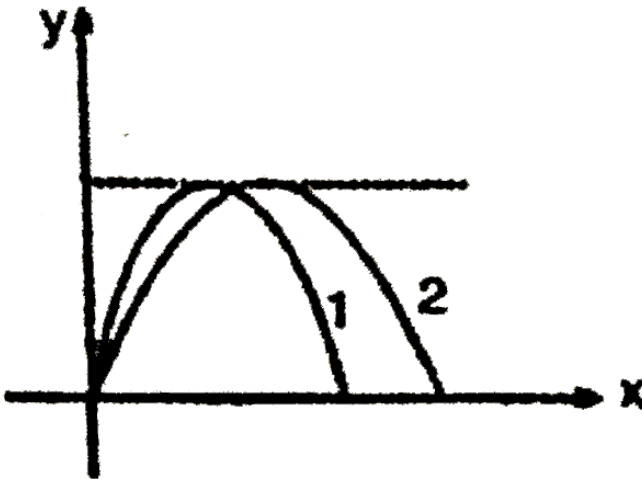

A. $T_2 > T_1$

B. $T_1 = T_2$

C. $u_1 > u_2$

D. $u_1 < u_2$

Answer: D



Watch Video Solution

17. The horizontal range and the maximum height of a projectile are equal. The angle of projection of the projectile is :

A. $\theta = \tan^{-1}\left(\frac{1}{4}\right)$

B. $\theta = \tan^{-1}(4)$

C. $\theta = \tan^{-1}(2)$

D. $\theta = 45^\circ$

Answer: B

 [Watch Video Solution](#)

18. A projectile fired with initial velocity u at some angle θ has a range R . If the initial velocity be doubled at the same angle of projection, then the range will be

- A. 20 m
- B. 40 m
- C. 120m
- D. 160 m

Answer: D

 [Watch Video Solution](#)

19. A ball thrown by one player reaches the other in $2s$. The maximum height attained by the ball above the point of projection will be about.

A. $2.5m$

B. $5m$

C. $7.5m$

D. $10m$

Answer: B



[Watch Video Solution](#)

Example

1. A scooter is moving along a straight line AB covers a distance of 360 m in 24 s and returns back from B to C and covers 240 m in 18 s. Find the total distance travelled by the scooter.



[Watch Video Solution](#)

2. A wheel completes 2000 revolutions to cover the 9.5 km. distance. then the diameter of the wheel is



[Watch Video Solution](#)

3. A man starts from his home and walks 50 m towards, then he turns towards east and walks 40 m and then reaches to his office after moving 20 m towards south.

(i) What is the total distance covered by the man from his home

to office ?

(ii) What is his displacement from his home to office ?

 [Watch Video Solution](#)

4. An object covers $\frac{1}{4}$ of the circular path, what will be the ratio of the distance and displacement of the object ?

 [Watch Video Solution](#)

5. Displacement of a person moving from X to Y along a semicircular path of radius r is 200 m. What is the distance travelled by him ?

 [Watch Video Solution](#)

6. An athlete complete one round of a circular track of diameter $200m$ in $40s$. What will be the distance covered and the displacement at the end of 2 minutes $20s$?

 [Watch Video Solution](#)

7. The distance covered by an object (in meter) is given by

$$s = 8t^3 - 7t^2 + 5t$$

Find its speed at $t = 2$ s.

 [Watch Video Solution](#)

8. Abdul while driving to school, computes the average speed for his trip to be $20kmh^{-1}$. On his return trip along the same route, there is less traffic and the average speed is $40kmh^{-1}$. What is the average speed for Abdul's trip ?



[Watch Video Solution](#)

9. A car moves from X to Y with a uniform speed v_u and returns to X with a uniform speed v_d . The average speed for this round trip is :

(a) $\frac{2v_d v_u}{v_d + v_u}$ (b) $\sqrt{v_u v_d}$ (c) $\frac{v_d v_u}{v_d + v_u}$ (d) $\frac{v_u + v_d}{2}$



[Watch Video Solution](#)

10. A particle travels along a straight line. It covers half the distance with a speed (v). The remaining part of the distance was covered with speed v_1 for half the time and with speed v_2 for the other half the time. Find the average speed of the particle over the entire motion.



[Watch Video Solution](#)

11. A car covers the first half of the distance between two places at a speed of 40kmh^{-1} and second half at 60kmh^{-1} . Calculate the average speed of the car.



[Watch Video Solution](#)

12. In one second, a particle goes from point A to point B moving in a semicircle (Fig). Find the magnitude of the average velocity.

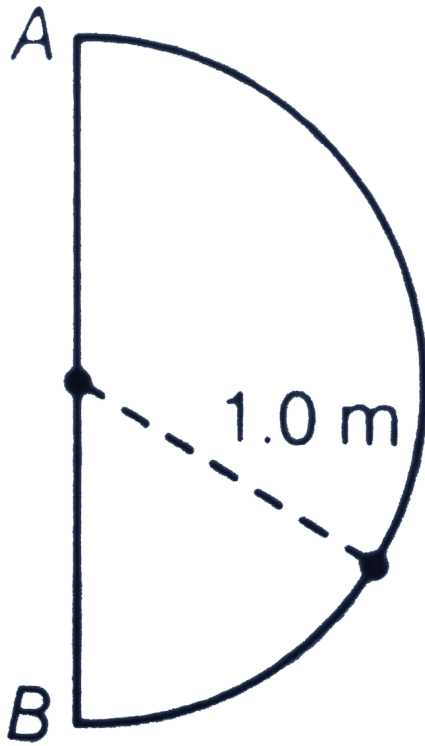

[▶ Watch Video Solution](#)

13. A farmer has to go 500 m due north, 400 m due east and 200 m due south to reach his field. If he takes 20 min to reach the field.

- (a) What distance he has to walk to reach the field ?
- (b) What is the displacement from his house to the field ?
- (c) What is the average speed of farmer during the walk ?
- (d) What is the average velocity of farmer during the walk ?

 [Watch Video Solution](#)

14. Joseph jogs from one end A to the other end B of a straight 300 m road in 2 min 50 s and then turns around and jogs 100 m back to point C in another 1 min. What are Joseph's average speeds and velocities in jogging (i) from A to B and (ii) from A to C ?

 [Watch Video Solution](#)

15. A car is moving along a straight line OP as shown in the figure. It moves from O to P in 18 s and returns from P to Q in 6 s. Which

of the following statements is not correct regarding the motion of the car ?

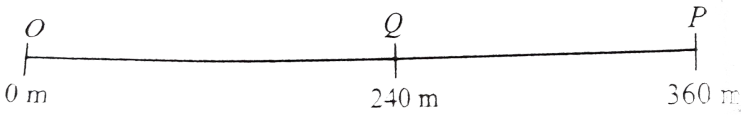

[▶ Watch Video Solution](#)

16. The position of object moving along an x-axis is given by $x = 3t - 4t^2 + t^3$, where x is in meters and t in seconds. Find the position of the object at the following values of t : (i) 2s, (ii) 4s, (iii) What is the object's displacement between t = 0 s and t = 4 s ? and (iv) What is its average velocity for the time interval from t = 2 s to t = 4 ?

[▶ Watch Video Solution](#)

17. The velocity of particle moving in the positive direction of x axis varies as $v = \alpha\sqrt{x}$, where α is a positive constant. Assuming that at moment $t = 0$, the particle was located at the point $x=0$. find.

(a) the time dependence of the velocity and the acceleration of the particle.

(b) the mean velocity of the particle averaged over the time that the particle takes to cover first s meters of the path

 [Watch Video Solution](#)

18. The distance travelled by an object moving along a straight line is directly proportional to the square of the time. Its acceleration

 [Watch Video Solution](#)

19. Give examples where a. the velocity of a particle is zero but its acceleration is not zero. b. the velocity is opposite in direction to the acceleration, c. the velocity is perpendicular to the acceleration.



[Watch Video Solution](#)

20. The velocity of a particle is given by $v = (2t^2 - 3t + 10) \text{ms}^{-1}$. Find the instantaneous acceleration at $t = 5 \text{ s}$.



[Watch Video Solution](#)

21. A particle is moving with a velocity of $v = (3 + 6t + 9t^2) \frac{\text{m}}{\text{s}}$.

Find out

(a) the acceleration of the particle at $t = 3 \text{ s}$.

(b) the displacement of the particle in the interval $t = 5s$ to $t = 8s$.



[Watch Video Solution](#)

22. The motion of a particle along a straight line is described by the function $x = (2t - 3)^2$, where x is in metres and t is in seconds. Find

(a) the position, velocity and acceleration at $t = 2s$.

(b) the velocity of the particle at origin.



[Watch Video Solution](#)

23. The radius vector of a point depends on time t , as

$$r = ct + \frac{bt^2}{2}$$

where c and b are constant vectors. Find the modulus of velocity and acceleration at any time t .



Watch Video Solution

24. A particle is moving in a straight line. Its displacement at any instant t is given by $x = 10t + 15t^3$, where x is in meters and t is in seconds. Find

- (i) the average acceleration in the interval $t = 0$ to $t = 2$ s and
- (ii) instantaneous acceleration at $t = 2$ s.



Watch Video Solution

25. (i) What does $\left| \frac{dv}{dt} \right|$ and $\frac{d|V|}{dt}$ represent ?

(ii) Can these be equal ?

(iii) Can $\frac{d|V|}{dt} = 0$ while $\left| \frac{dV}{dt} \right| \neq 0$?

(iv) Can $\frac{d|V|}{dt} \neq 0$ while $\left| \frac{dv}{dt} \right| = 0$?



Watch Video Solution

26. A car was moving at a rate of 18kmh^{-1} . When the brakes were applied, it comes to rest in a distance of 100 m. Calculate the retardation produced by the brakes.

 [Watch Video Solution](#)

27. Two cars start off a race with velocities 2m/s and 4m/s travel in straight line with uniform acceleration 2m/s^2 and 1m/s^2 respectively. What is the length of the path if they reach the final point at the same time ?

 [Watch Video Solution](#)

28. A body starting from rest has an acceleration of 4ms^{-2} . Calculate distance travelled by it in 5th second.

 [Watch Video Solution](#)

29. A train, travelling at 20km/hr is approaching a platform. A bird is sitting on a pole on the platform. When the train is at a distance of 2 km from pole, brakes are applied which produce uniform deceleration in it. At that instant the bird flies towards the train at 60km/hr and after touching the nearest point on the train flies back to the pole and then flies towards the train and continues repeating itself. Calculate how much distance will the bird have flown before the train stops?



Watch Video Solution

30. A particle starts with an initial velocity and passes successively over the two halves of a given distance with constant accelerations a_1 and a_2 respectively. Show that the final velocity

is the same as if the whole distance is covered with a uniform acceleration $\frac{a_1 + a_2}{2}$.

 [Watch Video Solution](#)

31. In a car race, car A takes a time t less than car B at the finish and passes the finishing point with speed v more than that of the car B. Assuming that both the cars start from rest and travel with constant acceleration a_1 and a_2 respectively. Show that $v = \sqrt{a_1 a_2} t$.

 [Watch Video Solution](#)

32. A particle starts from rest and moves under constant acceleration in a straight line. Find the ratio of displacement (a) in successive second and (b) in successive time interval t_0 .

 [Watch Video Solution](#)

33. Velocity and acceleration of a particle at time $t = 0$ are $u = (2\hat{i} + 3\hat{j})m/s$ and $a = (4\hat{i} + 3\hat{j})m/s^2$ respectively. Find the velocity and displacement of particle at $t = 2s$.

 [Watch Video Solution](#)

34. A ball is thrown upwards from the top of a tower $40m$ high with a velocity of $10m/s$. Find the time when it strikes the ground. Take $g = 10m/s^2$.

 [Watch Video Solution](#)

35. A pebble is thrown vertically upwards from a bridge with an initial velocity of $4.9ms^{-1}$. It strikes the water after $2s$. If

acceleration due to gravity does the pebble strike the water ?

 [Watch Video Solution](#)

36. A rocket is fired vertically up from the ground with a resultant vertical acceleration of $10m/s^2$. The fuel is finished in 1 min and it continues to move up. (a) What is the maximum height reached? (b) After how much time from then will the maximum height be reached? (Take $g = 10m/s^2$)

 [Watch Video Solution](#)

37. A juggler throws balls into air. He throws one when ever the previous one is at its highest point. If he throws n balls each second, the height to which each ball will rise is

 [Watch Video Solution](#)

38. From an elevated point A, a stone is projected vertically upwards. When the stone reaches a distance h below A, its velocity is double of what it was at a height h above A. Show that the greatest height attained by the stone is $\frac{5}{3}h$.



[Watch Video Solution](#)

39. A ball is thrown vertically upwards with a velocity of 20ms^{-1} from the top of a multistore building of 25 m high. How high will the ball rise? (Take $g = 10\text{ms}^{-2}$)



[Watch Video Solution](#)

40. A ball is thrown upwards from the ground with an initial speed of u . The ball is at height of 80m at two times, the time interval being 6 s. Find u . Take $g = 10\text{m/s}^2$.



Watch Video Solution

41. A particle of mass 1 kg has a velocity of $2m/s$. A constant force of 2 N acts on the particle for 1 s in a direction perpendicular to its initial velocity. Find the velocity and displacement of the particle at the end of 1 s .



Watch Video Solution

42. An open elevator is ascending with constant speed $v = 10m/s$. A ball is thrown vertically up by a boy on the lift when he is at a height $h = 10m$ from the ground. The velocity of projection is $v = 30m/s$ with respect to elevator. Find

(a) the maximum height attained by the ball.

(b) the time taken by the ball to meet the elevator again.

(c) time taken by the ball to reach the ground after crossing the elevator.

 [Watch Video Solution](#)

43. A particle is thrown vertically upwards from the surface of the earth. Let T_P be the time taken by the particle to travel from a point P above the earth to its highest point and back to the point P. Similarly, let T_Q be the time taken by the particle to travel from another point Q above the earth to its highest point and back to the same in terms of T_P , T_Q and H, is :-

 [Watch Video Solution](#)

44. Drop of water fall at regular intervals from roof of a building of height ($H=16$ m), the first drop striking the ground at the same moment as the fifth drop falls from the roof. The distances

between separate drops in air as the first drop reaches the ground are.



[Watch Video Solution](#)

45. A ball is dropped from the top of a tower. After 2 s another ball is thrown vertically downwards with a speed of 40ms^{-1} . After how much time and at what distance below the top of tower the balls meet ?



[Watch Video Solution](#)

46. Velocity-time equation of a particle moving in a straight line is,

$$v = (10 + 2t + 3t^2) \text{ (SI units) Find}$$

(a) displacement of particle from the mean position at time $t = 1\text{s}$, if it is given that displacement is 20m at time $t = 0$.

(b) acceleration-time equation.



Watch Video Solution

47. Displacement-time equation of a particle moving along x-axis is $x = 20 + t^3 - 12t$ (SI units)

- (a) Find, position and velocity of particle at time $t=0$.
- (b) State whether the motion is uniformly accelerated or not.
- (c) Find position of particle when velocity of particle is zero.



Watch Video Solution

48. With the help of the given velocity - time graph, find the

- (i) displacement in first three seconds and

(ii) acceleration for the graph.

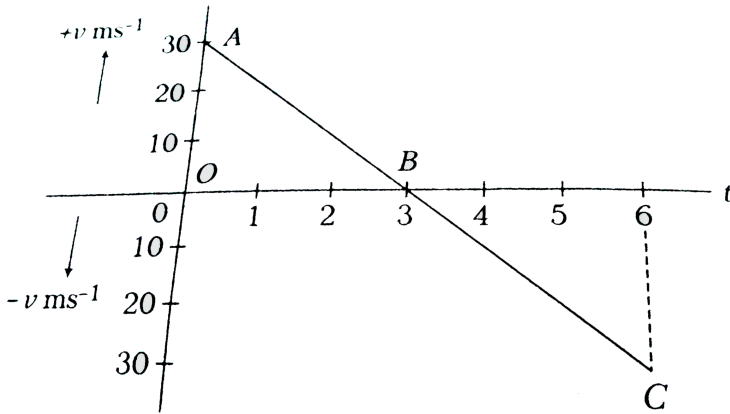

[Watch Video Solution](#)

49. Acceleration - time graph of a particle moving in a straight line is shown in figure. Velocity of particle at time $t = 0$ is 2ms^{-1} . Find

velocity at the end of fourth second.

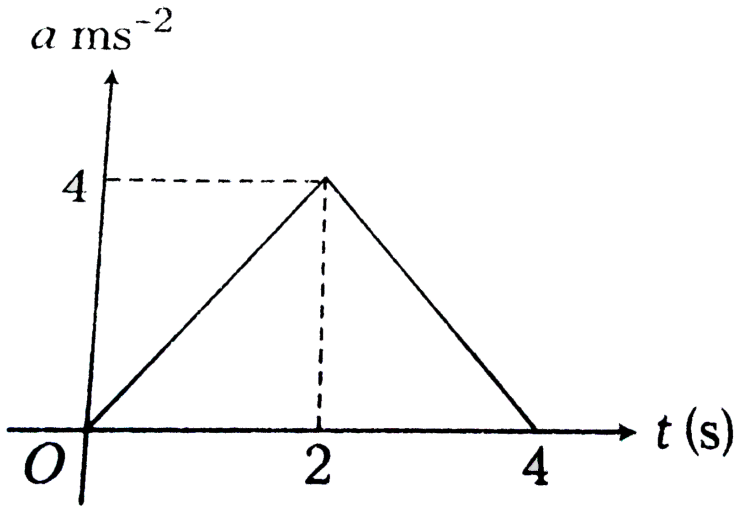

 [Watch Video Solution](#)

50. Displacement - time graph of particle moving in a straight line is as shown in figure. State whether the motion is accelerated or not. Describe the motion in detail. Given,

$$s_0 = 20\text{m and } t_0 = 4\text{s.}$$

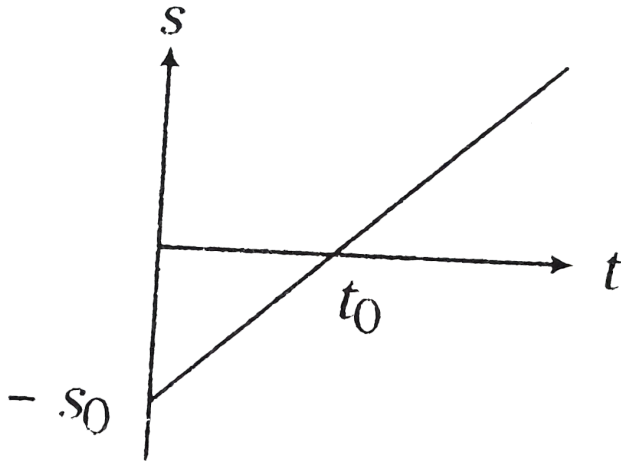

 [Watch Video Solution](#)

51. A particle is moving along the x-axis and its position-time graph is shown. Determine the sign of acceleration.

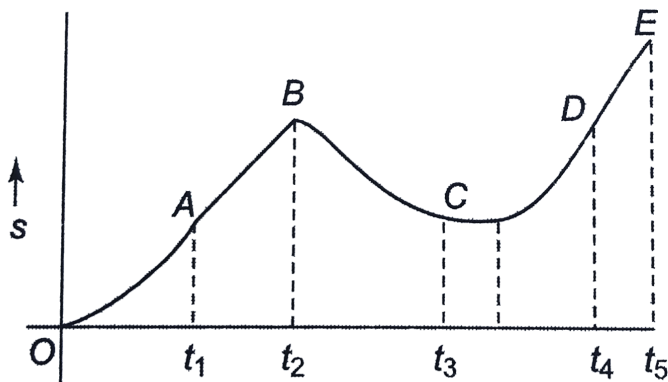



[Watch Video Solution](#)

52. A car accelerates from rest at a constant rate α for some time, after which it decelerates at a constant rate β , to come to rest. If the total time elapsed is t seconds. Then evaluate (a) the maximum velocity reached and (b) the total distance travelled.



[Watch Video Solution](#)

53. The acceleration versus time graph of a particle moving along a straight line is shown in the figure. Draw the respective velocity-

time graph Given $v = 0$ at $t = 0$.

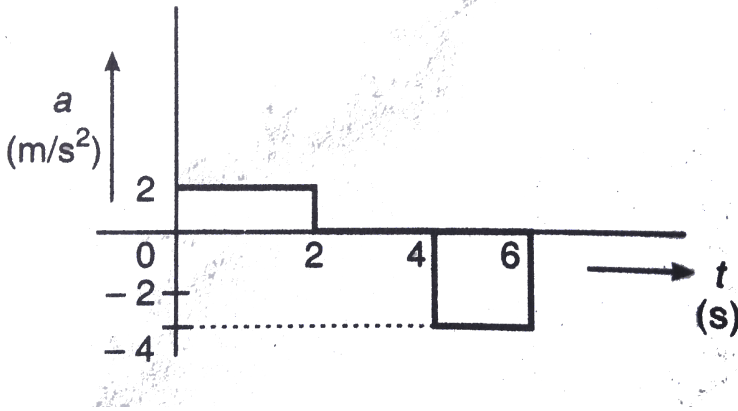

[▶ Watch Video Solution](#)

54. Velocity-time graph of a particle moving in a straight line is shown in figure. Plot the corresponding displacement-time graph

of the particle if at time $t = 0$, displacement $s = 0$.

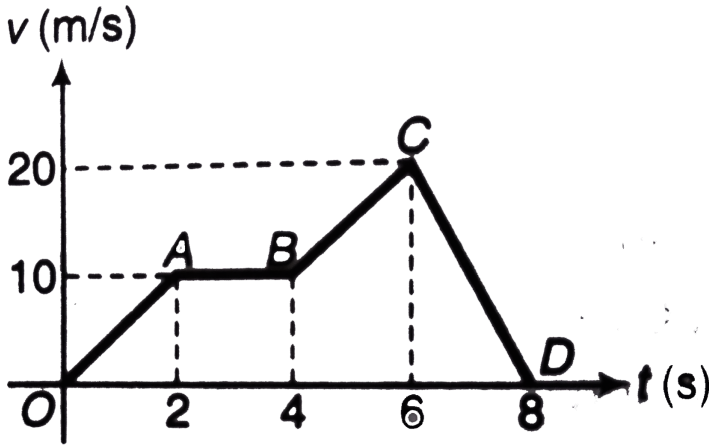

[Watch Video Solution](#)

55. A rocket is fired vertically upwards with a net acceleration of $4m/s^2$ and initial velocity zero. After $5s$ its fuel is finished and it decelerates with g . At the highest point its velocity becomes zero. Then, it accelerates downwards with acceleration g and return back to ground. Plot velocity-time and displacement -time graphs for the complete journey. Take $g = 10m/s^2$.

[Watch Video Solution](#)

56. Anoop is moving due east with a velocity of $1m/s$ and Dhyani is moving due west with a velocity of $2m/s$. what is the velocity of Anoop with respect to Dhyani?

 [Watch Video Solution](#)

57. Two parallel rail tracks run north-south. On one track train A moves north with a speed of $54kmh^{-1}$ and on the other track train B moves south with a speed of $90kmh^{-1}$. The velocity of train A with respect to train B is

 [Watch Video Solution](#)

58. A man A moves due to East with velocity $6ms^{-1}$ and another man B moves in $N - 30^\circ E$ with $6ms^{-1}$. Find the velocity of B

w.r.t. A.



[Watch Video Solution](#)

59. Buses A and B are moving in the same direction with speed 20ms^{-1} and 15ms^{-1} respectively. Find the relative velocity of A w.r.t. B and relative velocity of B w.r.t. A.



[Watch Video Solution](#)

60. Car A has an acceleration of $2\text{m}/\text{s}^2$ due east and car B, $4\text{m}/\text{s}^2$. due north. What is the acceleration of car B with respect to car A?



[Watch Video Solution](#)

61. A police van moving on a highway with a speed of 30kmh^{-1} fires a bullet at a thief's car speeding away in a same direction with a speed of 192kmh^{-1} . If the muzzle speed of the bullet is 150ms^{-1} , with what speed does the bullet hit thief's car? .

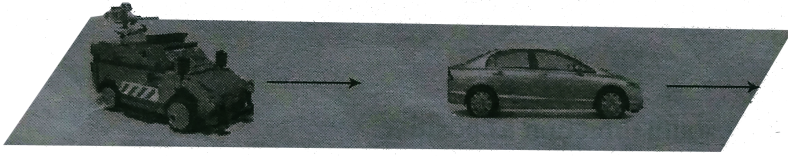

[Watch Video Solution](#)

62. Delhi is at a distance of 200 km from Ambala. Car A set out from Ambala at a speed of 30kmh^{-1} and car B set out at the same time from Delhi at a speed of 20kmh^{-1} . When they will meet each other? What is the distance of that meeting point from Ambala?

[Watch Video Solution](#)

63. Two cars are travelling towards each other on a straight road with velocities 10ms^{-1} and 12ms^{-1} respectively. When they are 150 m apart, both drivers apply their brakes and each car decelerates at 2ms^{-2} until it stops. How far apart will they be when they have come to rest?



[Watch Video Solution](#)

64. To a man walking at the rate of $3\text{km}/\text{h}$ the rain appear to fall vertically downwards. When he increases his speed $6\text{km}/\text{h}$ it appears to meet him at an angle of 45° with vertically. Find the speed of rain.



[Watch Video Solution](#)

65. A man crosses a river in a boat. If he cross the river in minimum time he takes 10 min with a drift $120m$. If he crosses the river taking shortest path, he takes 12.5 min , find

- (a) width of the river
- (b) velocity of the boat with respect to water
- (c) speed of the current

 [Watch Video Solution](#)

66. A man wants to reach point B on the opposite bank of a river flowing at a speed as shown in figure. What minimum speed relative to water should the man have so that he can reach point B? In which direction should he swim?

 [Watch Video Solution](#)

67. A man can row a boat with 4 km/h in still water, if he is crossing a river where the current is 2 km/h .

(a) In what direction will his boat be held, if he wants to reach a point on the other bank, directly opposite to starting point?

(b) If width of the river 4 km , how long will the man take to cross the river, with the condition in part (a)?

(c) In what direction should he head the boat if he wants to cross the river in shortest time and what is this minimum time?

(d) How long will it take him to row 2 km up the stream and then back to his starting point?



[Watch Video Solution](#)

68. A boat moves relative to water with a velocity v which is n times less than the river flow velocity u . At what angle to the stream direction must the boat move to minimize drifting?

 [Watch Video Solution](#)

69. Car A and car B start moving simultaneously in the same direction along the line joining them. Car A moves with a constant acceleration $a = 4m/s^2$, while car B moves with a constant velocity $v = 1m/s$. At time $t = 0$, car A is $10m$ behind car B. Find the time when car A overtake car B.

 [Watch Video Solution](#)

70. An open lift is moving upward with velocity $10m/s$. It has an upward acceleration of $2m/s^2$. A ball is projected upwards with velocity $20m/s$ relative to ground. Find

(a) time when ball again meets the lift

(b) displacement of lift and ball at that instant.

Take $g = 10m/s^2$



 [Watch Video Solution](#)

71. Two ships A and B are 10km apart on a line running south to north. Ship A farther north is streaming west at $20\text{km}/\text{h}$ and ship B is streaming north at $20\text{km}/\text{h}$. What is their distance of closest approach and how long do they take to reach it?

 [Watch Video Solution](#)

72. An aeroplane has to go from a point O to another point A, at distance d due 37° East of North. A wind is blowing due North at a speed of 10ms^{-1} . The air speed of the plane is v . (i) Find the direction in which the pilot should head the plane to reach the

point A. (ii) Find the time taken by the plane to go from O to A.

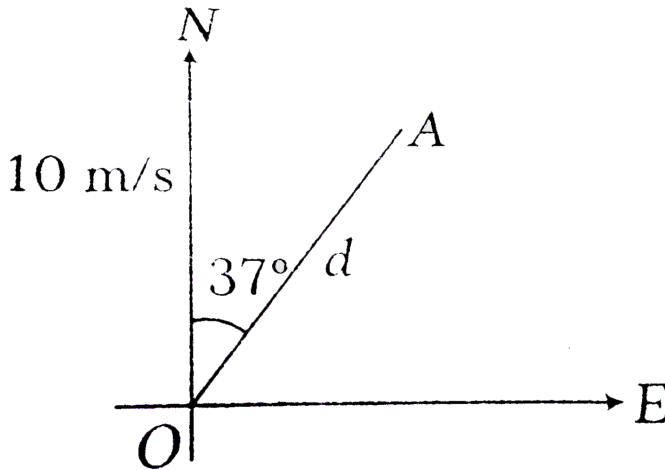

[Watch Video Solution](#)

73. An aircraft flies at 400 km/h in still air. A wind of $200\sqrt{2}\text{ km/h}$ is blowing from the south towards north. The pilot wishes to travel from A to a point B north east of A. Find the direction he must steer and time of his journey if $AB = 1000\text{ km}$.

[Watch Video Solution](#)

Check point 3.1

1. Which of the following is a one-dimensional motion ?

- A. Landing of an aircraft
- B. Earth revolving around the sun
- C. Motion of wheels of moving
- D. Train running on a straight track

Answer: D



[Watch Video Solution](#)

2. A person moves towards East for 3 m, then towards North for 4 m and then moves vertically up by 5 m. What is his distance now from the starting point ?

A. $5\sqrt{2}m$

B. 5 m

C. 10 m

D. 20 m

Answer: A



Watch Video Solution

3. A particle moves in a of radius R from A to B , as shown in the figure. Find the distance and displacement covered.

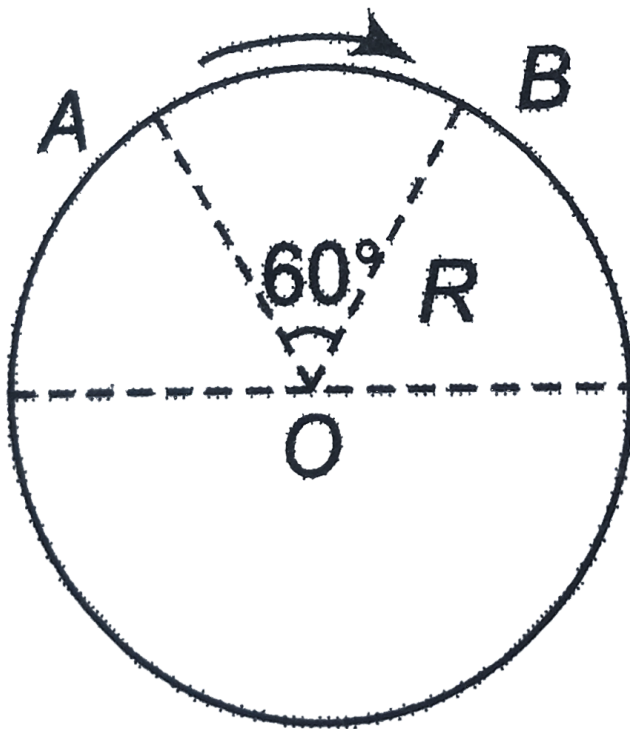

- A. $\frac{\pi R}{3}$
- B. $\frac{\pi R}{2}$
- C. $\frac{\pi R}{4}$
- D. πR

Answer: A



Watch Video Solution

4. A person moves 30m north,, *then* 20 m towards east and finally $30\sqrt{2}\text{m}$ in south-west direction. The displacement of the person from the origin will be

- A. 10 m along North
- B. 10 m long South
- C. 10 m along West
- D. Zero

Answer: C



[Watch Video Solution](#)

5. An aeroplane flies 400 m north and 300m south and then flies 1200 m upwards then net displacement is

A. 1200 m

B. 1300 m

C. 1400 m

D. 1500 m

Answer: A



Watch Video Solution

6. A wheel of radius $1m$ rolls forward half a revolution on a horizontal ground. The magnitude of the displacement of the point of the wheel initially on contact with the ground is.

A. 2π

B. $\sqrt{2}\pi$

C. $\sqrt{\pi^2 + 4}$

D. π

Answer: C



Watch Video Solution

7. The three initial and final position of a man on the X-axis are given as

(i) $(-8m, 7m)$ (ii) $(7m, -3m)$

(iii) $(-7m, 3m)$

Which pair gives the negative displacement ?

A. (i)

B. (ii)

C. (iii)

D. (i) and (iii)

Answer: B

 [Watch Video Solution](#)

8. A particle moves along a circular path of radius R . The distance and displacement of a particle after one complete revolution is

A. $0, 2\pi r$

B. $2\pi r, 0$

C. $0, \pi r$

D. $\pi r, 0$

Answer: B

 [Watch Video Solution](#)

9. A particle starts from the origin, goes along the X-axis to the point $(20m, 0)$ and then returns along the same line to the point $(-20m, 0)$. Find the distance and displacement of the particle during the trip.

- A. 40 m, 0
- B. 40 m, 20 m
- C. $40m, -20m$
- D. $60m, -20m$

Answer: D



[Watch Video Solution](#)

10. The numerical ratio of displacement to the distance covered is always

- A. less than one
- B. equal to one
- C. equal to or less than one
- D. equal to or greater than one

Answer: C

 [Watch Video Solution](#)

Check point 3.2

1. A car moves for half of its time at $80\text{km}/\text{h}$ and for rest of time at $40\text{km}/\text{h}$. Total distance covered is 60km . What is the average speed of the car

A. 60kmh^{-1}

B. 80kmh^{-1}

C. 120kmh^{-1}

D. 180kmh^{-1}

Answer: A



Watch Video Solution

2. During the first 18 min of a 60 min trip, a car has an average speed of 11ms^{-1} . What should be the average speed for remaining 42 min so that car is having an average speed of 21ms^{-1} for the entire trip?

A. 25.3ms^{-1}

B. 29.2ms^{-1}

C. 31ms^{-1}

D. $35.6ms^{-1}$

Answer: A



Watch Video Solution

3. A man walks on a straight road from his home to a market $2.5km$ away a speed of $5kmh^{-1}$. Finding the market closed, he instantly turns and walks back home with a speed of $7.5kmh^{-1}$. The average speed of the man over the interval of time 0 to 50 min is equal to

A. $5kmh^{-1}$

B. $\frac{25}{4}kmh^{-1}$

C. $\frac{30}{4}kmh^{-1}$

D. $\frac{45}{8}kmh^{-1}$

Answer: D

 [Watch Video Solution](#)

4. A particle is constrained to move on a straight line path. It returns to the starting point after 10 sec . The total distance covered by the particle during this time is 30 m . Which of the following statements about the motion of the particle is false

- A. Displacement of the particle is zero
- B. Average speed of the particle is $3ms^{-1}$
- C. Displacement of the particle 30 m
- D. Both (a) and (b)

Answer: D

 [Watch Video Solution](#)

5. A 150m long train is moving with a uniform velocity of 45km/h . The time taken by the train to cross a bridge of length 850 metres is.

A. 56 s

B. 68 s

C. 80 s

D. 92 s

Answer: C

 [Watch Video Solution](#)

6. The displacement of a particle starting from rest (at $t = 0$) is given by $s = 6t^2 - t^3$. The time in seconds at which the particle will attain zero velocity again, is

A. 2

B. 4

C. 6

D. 8

Answer: B



Watch Video Solution

7. An insect crawls a distance of 4 m along North in 10 s and then a distance of 3 m along East in 5 s. The average velocity of the insect is

A. $\frac{7}{15} \text{ms}^{-1}$

B. $\frac{1}{5} \text{ms}^{-1}$

C. $\frac{1}{3} \text{ms}^{-1}$

D. $\frac{4}{5}ms^{-1}$

Answer: C

 [Watch Video Solution](#)

8. A point traversed $3/4$ th of the circle of radius R in time t . The magnitude of the average velocity of the particle in this time interval is

A. $\frac{\pi R}{t}$

B. $\frac{3\pi R}{2t}$

C. $\frac{R\sqrt{2}}{t}$

D. $\frac{R}{\sqrt{2}t}$

Answer: C

 [Watch Video Solution](#)

9. A boy is running over a circular track with uniform speed of 10ms^{-1} . What is the average velocity for movement of boy from A to B (in ms^{-1}) ?

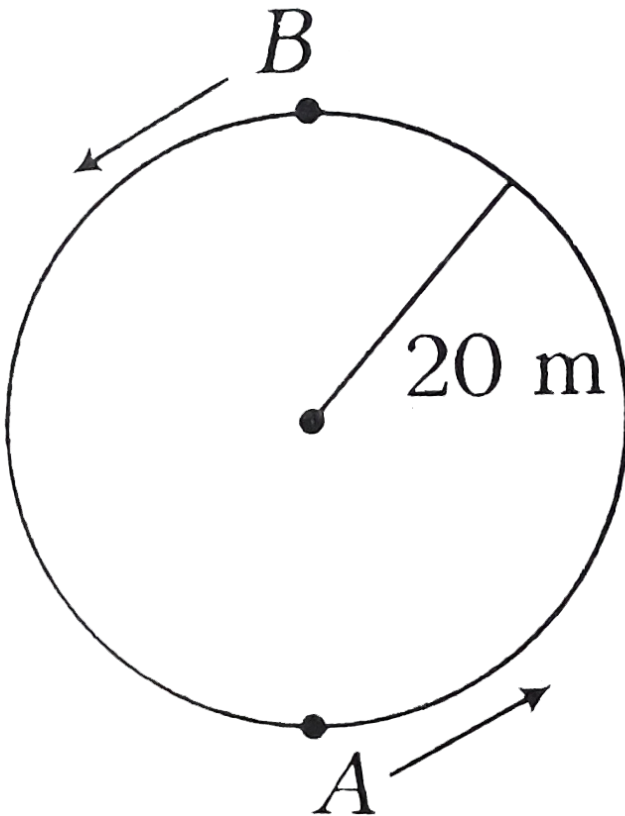

A. $\frac{10}{\pi}$

B. $\frac{40}{\pi}$

C. 10

D. None of these

Answer: D



Watch Video Solution

10. The displacement x of an object is given as a function of time,

$x = 2t + 3t^2$. The instantaneous velocity of the object at $t = 2$ s is

A. $16ms^{-1}$

B. $14ms^{-1}$

C. $10ms^{-1}$

D. $12ms^{-1}$

Answer: B

 [Watch Video Solution](#)

Check point 3.3

1. Acceleration of a particle changes when

- A. direction of velocity changes
- B. magnitude of velocity changes
- C. Both (a) and (b)
- D. speed changes

Answer: C

 [Watch Video Solution](#)

2. If a particle moves with an acceleration, then which of the following can remain constant ?

- A. Both speed and velocity
- B. Neither speed nor velocity
- C. Only the velocity
- D. Only the speed

Answer: D

 [Watch Video Solution](#)

3. The average velocity of a body moving with uniform acceleration after travelling a distance of $3.06m$ is $0.34ms^{-1}$. If the change in velocity of the body is $0.18ms^{-1}$ during this time, its uniform acceleration is .

A. $0.01ms^{-2}$

B. $0.02ms^{-2}$

C. $0.03ms^{-2}$

D. $0.04ms^{-2}$

Answer: B



Watch Video Solution

4. The displacement x of a particle at time t along a straight line is given by $x = \alpha - \beta t + \gamma t^2$. The acceleraion of the particle is

A. $-\beta$

B. $-\beta + 2\gamma$

C. 2γ

D. -2γ

Answer: C

 [Watch Video Solution](#)

5. A car travelling with a velocity of 80 km/h slowed down to 44 km/h in 15 s. The retardation is

A. $0.67ms^{-2}$

B. $1ms^{-2}$

C. $1.25ms^{-2}$

D. $1.5ms^{-2}$

Answer: A

 [Watch Video Solution](#)

6. A body is moving with velocity $30m/s$ towards east. After $10s$ its velocity becomes $40m/s$ towards north. The average acceleration of the body is.

A. $7ms^{-2}$

B. $\sqrt{7}ms^{-2}$

C. $5ms^{-2}$

D. $1ms^{-2}$

Answer: C



Watch Video Solution

7. The displacement (in metre) of a particle moving along X-axis is given by $x = 18t + 5t^2$. The average acceleration during the interval $t_1 = 2s$ and $t_2 = 4s$ is

A. $13ms^{-2}$

B. $10ms^{-2}$

C. $27ms^{-2}$

D. $37ms^{-2}$

Answer: B

 [Watch Video Solution](#)

8. The distance traversed by a particle moving along a straight line is given by $x = 180t + 50t^2$ metre. The acceleration of the particle is

A. $180ms^{-2}$

B. $580ms^{-2}$

C. $100ms^{-2}$

D. $50ms^{-2}$

Answer: C

 [Watch Video Solution](#)

9. The displacement (in metre) of a particle moving along x-axis is given by $x = 18t + 5t^2$ Calculate (i) instantaneous acceleration.

A. $18ms^{-2}$

B. $10ms^{-2}$

C. $5ms^{-2}$

D. $1ms^{-2}$

Answer: B

 [Watch Video Solution](#)

10. A particle velocity changes from $(2\hat{i} + 3\hat{j})ms^{-1}$ to $(2\hat{i} - 3\hat{j})ms^{-1}$ in 2 s. The acceleration in ms^{-2} is

A. $-(\hat{i} + 5\hat{j})$

B. $(\hat{i} + 5\hat{j})/2$

C. zero

D. $(-3\hat{j})$

Answer: D



Watch Video Solution

Check point 3.4

1. An object is moving velocity $10ms^{-1}$. A constant force acts for 4 s object and given it a speed of $2ms^{-1}$ in opposite direction.

The acceleration produced is

A. $3ms^{-2}$

B. $-3ms^{-2}$

C. $6ms^{-2}$

D. $-6ms^{-2}$

Answer: B



Watch Video Solution

2. Velocity of a body moving a straight line with uniform acceleration (a) reduces by $\frac{3}{4}$ of its initial velocity in time t_0 . The total time of motion of the body till its velocity becomes zero is

A. $\frac{4}{3}t_0$

B. $\frac{3}{2}t_0$

C. $\frac{1}{3}t_0$

D. $\frac{8}{3}t_0$

Answer: A

 [Watch Video Solution](#)

3. The distance travelled by a particle is proportional to the squares of time, then the particle travels with

A. uniform acceleration

B. uniform velocity

C. Both of these

D. speed changes

Answer: A

 [Watch Video Solution](#)

4. The displacement of a body in 8 s starting from rest with an acceleration of 20cm s^{-2} is

- A. 64 m
- B. 64 cm
- C. 640 cm
- D. 0.064m

Answer: C



Watch Video Solution

5. A particle starts with a velocity of 2m/s and moves in a straight line with a retardation of 0.1m/s^2 . The time that it takes to describe 15m is

A. 10 s

B. 20 s

C. 30 s

D. 40 s

Answer: A



Watch Video Solution

6. A particle starts from rest accelerates at $2m/s^2$ for $10s$ and then goes for constant speed for $30s$ and then decelerates at $4m/s^2$ till it stops. What is the distance travelled by it.

A. 750 m

B. 800 m

C. 700 m

D. 850 m

Answer: A

 [Watch Video Solution](#)

7. The motion of a particle is described by the equation at $u = at$.
The distance travelled by the particle in the first 4 seconds

A. $4a$

B. $12a$

C. $6a$

D. $8a$

Answer: D

 [Watch Video Solution](#)

8. A body is moving with uniform velocity of $8ms^{-1}$. When the body just crossed another body, the second one starts and moves with uniform acceleration of $4ms^{-2}$. The time after which two bodies meet will be :

A. 2 s

B. 4 s

C. 6 s

D. 8 s

Answer: B



[Watch Video Solution](#)

9. Two bodies A and B start from rest from the same point with a uniform acceleration of $2ms^{-2}$. If B starts one second later, then

the two bodies are separated , at the end of the next second, by

A. 1 m

B. 2 m

C. 3 m

D. 4 m

Answer: C



[Watch Video Solution](#)

10. The displacement of a particle moving in a straight line is described by the relation $s = 6 + 12t - 2t^2$. Here s is in metre and t in second. The distance covered by the particle in first 5s is

A. 20 m

B. 32 m

C. 24 m

D. 26 m

Answer: D



Watch Video Solution

11. A train accelerating uniformly from rest attains a maximum speed of 40ms^{-1} in 20s . It travels at this speed for 20s and is brought to rest with uniform retardation in further 40s . What is the average velocity during this period?

A. $80/3\text{ms}^{-1}$

B. 40ms^{-1}

C. 25ms^{-1}

D. 30ms^{-1}

Answer: C

 [Watch Video Solution](#)

12. A particle starts from rest and traverses a distance l with uniform acceleration, then moves uniformly over a further distance $2l$ and finally comes to rest after moving a further distance $3l$ under uniform retardation. Assuming entire motion to be rectilinear motion the ratio of average speed over the journey to the maximum speed on its ways is

A. $1/5$

B. $2/5$

C. $3/5$

D. $4/5$

Answer: C



Watch Video Solution

13. A body travelling with uniform acceleration crosses two point A and B with velocities $20ms^{-1}$ and $30ms^{-1}$ respectively. The speed of the body at the mid-point of A and B is.

A. $25ms^{-1}$

B. $25.5ms^{-1}$

C. $24ms^{-1}$

D. $10\sqrt{6}ms^{-1}$

Answer: B



Watch Video Solution

14. The velocity of a particle moving in the positive direction of X-axis varies as $v = 5\sqrt{x}$. Assuming that at $t = 0$, particle was at $x = 0$. What is the acceleration of the particle ?

A. $12.5ms^{-2}$

B. $7.5ms^{-2}$

C. $5ms^{-2}$

D. $2.5ms^{-2}$

Answer: A



[Watch Video Solution](#)

15. If a body starts from rest and travels 120 cm in the 6 second then what is the acceleration

A. $0.20ms^{-2}$

B. $0.027ms^{-2}$

C. $0.218ms^{-2}$

D. $0.03ms^{-2}$

Answer: C

 [Watch Video Solution](#)

Check point 3.5

1. Free fall on an object in vacuum is a case of motion with

A. uniform velocity

B. uniform acceleration

C. variable acceleration

D. constant momentum

Answer: B

 [Watch Video Solution](#)

2. With what speed should a body be thrown upwards so that the distances traversed in 5th second and 6th second are equal?

A. $5.84ms^{-1}$

B. $49ms^{-1}$

C. $\sqrt{98}ms^{-1}$

D. $98ms^{-1}$

Answer: B

 [Watch Video Solution](#)

3. If a ball is thrown vertically upwards with speed u , the distance covered during the last t second of its ascent is

A. $ut - (gt^2 / 2)$

B. $(u + gt)t$

C. ut

D. $gt^2 / 2$

Answer: D

 [Watch Video Solution](#)

4. A person throws balls into the air one after the other at an interval of one second. The next ball is thrown when the velocity of the ball thrown earlier is zero. To what height the ball rise:

A. 2 m

B. 5 m

C. 8 m

D. 10 m

Answer: B



Watch Video Solution

5. An object thrown vertically up from the ground passes the height 5 m twice in an interval of 10 s. What is its time of flight?

A. $52ms^{-1}$

B. $61ms^{-1}$

C. $45ms^{-1}$

D. $26ms^{-1}$

Answer: A

 [Watch Video Solution](#)

6. If a stone is thrown up with a velocity of $9.8ms^{-1}$, then how much time will it take to come back ?

A. 1 s

B. 2 s

C. 3 s

D. 4 s

Answer: B

 [Watch Video Solution](#)

7. A stone falls freely rest. The distance covered by it in the last second is equal to the distance covered by it in the first 2 s. The time taken by the stone to reach the ground is

A. 5 s

B. 12 s

C. 15 s

D. 8 s

Answer: A



[Watch Video Solution](#)

8. A stone is thrown vertically upwards with an initial speed u from the top of a tower, reaches the ground with a speed $3u$. The height of the tower is :

A. $3u^2 / g$

B. $4u^2 / g$

C. $6u^2 / g$

D. $9u^2 / g$

Answer: B



Watch Video Solution

9. A body is thrown vertically upwards from A . The top of a tower . It reaches the ground in time t_1 . If it is thrown vertically downwards from A with the same speed it reaches the ground in time t_2 , If it is allowed to fall freely from A . then the time it takes

to reach the ground.

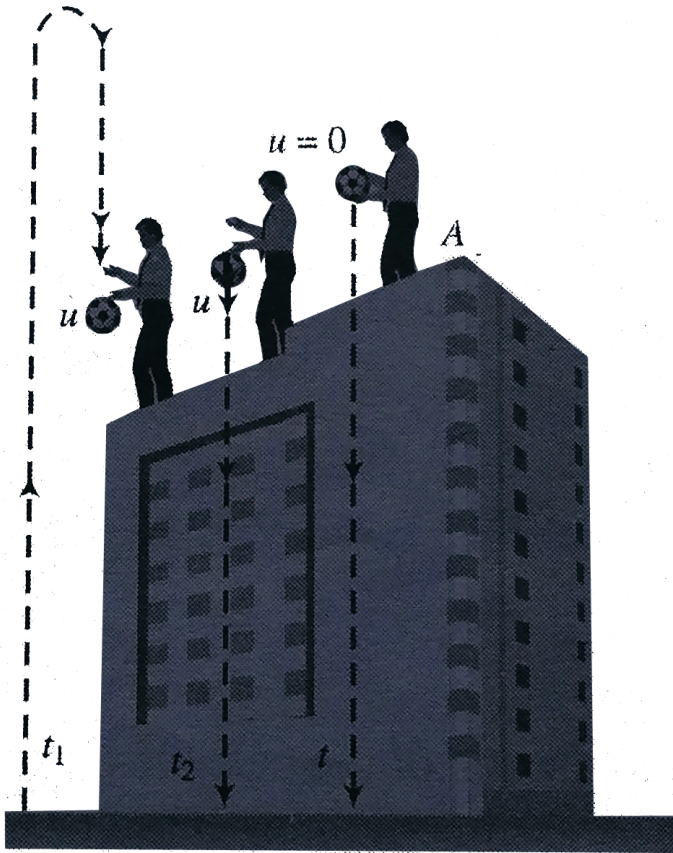

A. $t = \frac{t_1 + t_2}{2}$

B. $t = \frac{t_1 - t_2}{2}$

C. $t = \sqrt{t_1 t_2}$

D. $t = \sqrt{\frac{t_1}{t_2}}$

Answer: C

 [Watch Video Solution](#)

10. A body is projected upwards with a velocity u . It passes through a certain point above the ground after t_1 , Find the time after which the body passes through the same point during the journey.

A. $\left(\frac{u}{g} - t_1^2\right)$

B. $2\left(\frac{u}{g} - t_1\right)$

C. $\left(\frac{u}{g} - t_1\right)$

D. $\left(\frac{u^2}{g^2} - t_1\right)$

Answer: B

 [Watch Video Solution](#)

11. A helicopter rises from rest on the ground vertically upwards with a constant acceleration g . A food packet is dropped from the helicopter when it is at a height h . The time taken by the packet to reach the ground is close to [g is the acceleration due to gravity] :

A. $t_1 < t_2$

B. $t_1 = t_2$

C. $t_1 > t_2$

D. Data insufficient

Answer: C



Watch Video Solution

12. A particle (A) is dropped from a height and another particle (B) is thrown in horizontal direction with speed of 5 m/s from the

same height. The correct statement is

- A. ball P reaches the ground first
- B. ball Q reaches the ground first
- C. Both reach the ground at the same time
- D. the respective masses of the two balls will decide the time

Answer: C

 [Watch Video Solution](#)

13. A particle is dropped from top of tower. During its motion it covers $\frac{9}{25}$ part of height of tower in last 1 sec. Then find height of the tower.

- A. 100 m
- B. 12.5m

C. 145 m

D. 167.5m

Answer: B



Watch Video Solution

14. A ball dropped from the top of a tower covers a distance $7x$ in the last second of its journey, where x is the distance covered in the first second. How much time does it take to reach to ground?.

A. 3 s

B. 4 s

C. 5 s

D. 6 s

Answer: B



Watch Video Solution

15. A body falls from a height $h = 200m$ (at New Delhi). The ratio of distance travelled in each 2 sec during $t = 0$ to $t = 6$ seconds of the journey is.

A. 1 : 4 : 9

B. 1 : 2 : 4

C. 1 : 3 : 5

D. 1 : 2 : 3

Answer: C



Watch Video Solution

16. A stone is thrown vertically upwards. When stone is at a height half of its maximum height, its speed is 10 m/s , then maximum height attained by the stone is ($g = 10\text{ m/s}^2$)

A. 16 m

B. 10 m

C. 20 m

D. 40 m

Answer: B



[Watch Video Solution](#)

17. When a ball is thrown up vertically with velocity v_0 , it reaches a maximum height of h . If one wishes to triple the maximum height then the ball should be thrown with velocity

A. $\sqrt{3}v_0$

B. $3v_0$

C. $9v_0$

D. $3/2v_0$

Answer: A



Watch Video Solution

18. A man in a balloon rising vertically with acceleration $4.9m/s^2$ of releases a ball 2 sec after the balloon is let go from the ground.

The greatest height above ground reached by the ball is :

$(g = 9.8m/s^2)$

A. $14.7m$

B. $19.6m$

C. $9.8m$

D. $24.5m$

Answer: A

 [Watch Video Solution](#)

19. A body freely falling from the rest has velocity v after it falls through a height h the distance it has to fall down for its velocity to become double is

A. $8 h$

B. $6 h$

C. $4 h$

D. $5 h$

Answer: C



Watch Video Solution

20. Two balls are dropped from heights h and $2h$ respectively from the earth surface. The ratio of time of these balls to reach the earth is.

A. $1 : \sqrt{2}$

B. $\sqrt{2} : 1$

C. $2 : 1$

D. $1 : 2$

Answer: A



Watch Video Solution

21. An aeroplane is moving with a velocity u . It drops a packet from a height h . The time t taken by the packet in reaching the ground will be

A. $\sqrt{\left(\frac{2g}{h}\right)}$

B. $\sqrt{\left(\frac{2u}{g}\right)}$

C. $\sqrt{\left(\frac{h}{2g}\right)}$

D. $\sqrt{\left(\frac{2h}{g}\right)}$

Answer: D

 [Watch Video Solution](#)

22. For a particle moving along a straight line, the displacement x depends on time t as $x = \alpha t^3 + \beta t^2 + \gamma t + \delta$. The ratio of its initial acceleration to its initial velocity depends

A. only on α and γ

B. only on β and γ

C. only on α and β

D. only on α

Answer: B



Watch Video Solution

23. The acceleration of a particle is increasing linearly with time t as bt . The particle starts from the origin with an initial velocity v_0 .

The distance travelled by the particle in time t will be

A. $v_0t + \frac{1}{6}bt^3$

B. $v_0t + \frac{1}{3}bt^3$

C. $v_0t + \frac{1}{3}bt^2$

D. $v_0t + \frac{1}{2}bt^2$

Answer: A



Watch Video Solution

24. The acceleration a in ms^{-2} of a particle is given by $a = 3t^2 + 2t + 2$, where t is the time. If the particle starts out with a velocity $v = 2ms^{-1}$ at $t = 0$, then find the velocity at the end of $2s$.

A. $12ms^{-1}$

B. $14ms^{-1}$

C. $16ms^{-1}$

D. $18ms^{-1}$

Answer: C



Watch Video Solution

25. A particle is moving such that $s = t^3 - 6t^2 + 18t + 9$, where s is in meters and t is in seconds. Find the minimum velocity attained by the particle.

A. $29ms^{-1}$

B. $5ms^{-1}$

C. $6ms^{-1}$

D. $12ms^{-1}$

Answer: C



Watch Video Solution

Check point 3.6

1. Which of the following graph represents uniform motion

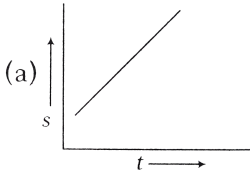

A.

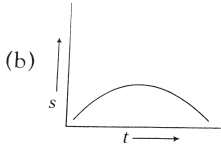

B.

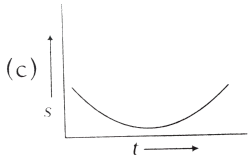

C.

D. None of these

Answer: A



Watch Video Solution

2. From the following displacement-time graph find out the velocity of a moving body.

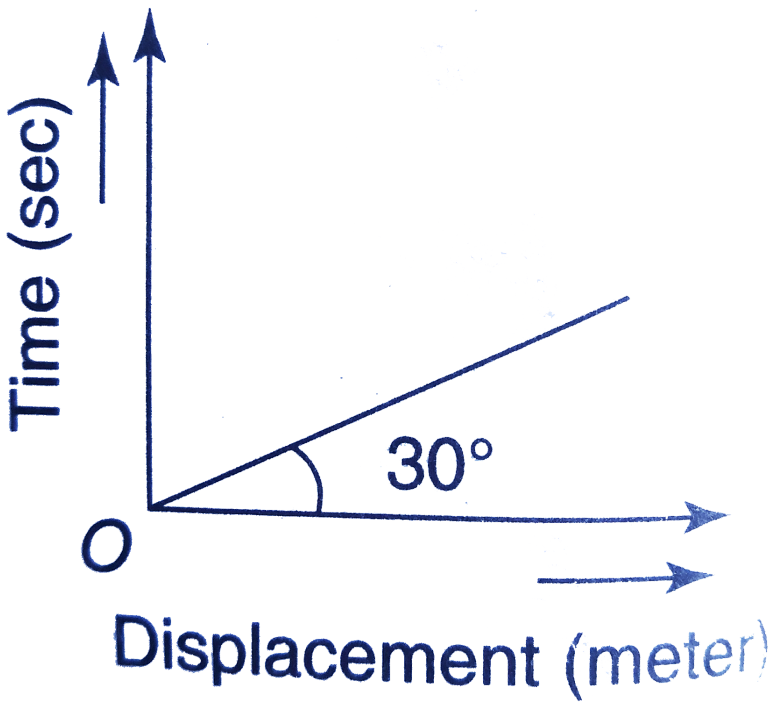

A. $\frac{1}{\sqrt{3}}ms^{-1}$

B. $3ms^{-1}$

C. $\sqrt{3}ms^{-1}$

D. $\frac{1}{3}ms^{-1}$

Answer: C



Watch Video Solution

3. The distance time graph of a particle at time t makes angle 45° with respect to time axis. After $1s$, it makes angle 60° with respect to time axis. What is the acceleration of the particle?

A. $\sqrt{3} - 1$

B. $\sqrt{3} + 1$

C. $\sqrt{3}$

D. 1

Answer: A



Watch Video Solution

4. The graph between displacement and time for a particle moving with uniform acceleration is a

- A. straight line with a positive slope
- B. parabola
- C. ellipse
- D. straight line parallel to time axis

Answer: B

 [Watch Video Solution](#)

5. The $v - t$ graph of a moving object is given in figure. The maximum acceleration is

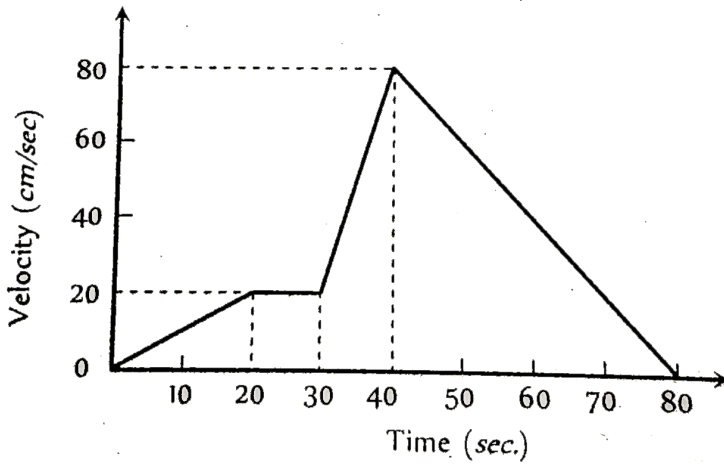

A. 1cm s^{-2}

B. 2cm s^{-2}

C. 3cm s^{-2}

D. 6cm s^{-2}

Answer: D



Watch Video Solution

6. The variation of velocity of a particle with time moving along a straight line is illustrated in the following figure. The distance travelled by the particle in four seconds is.

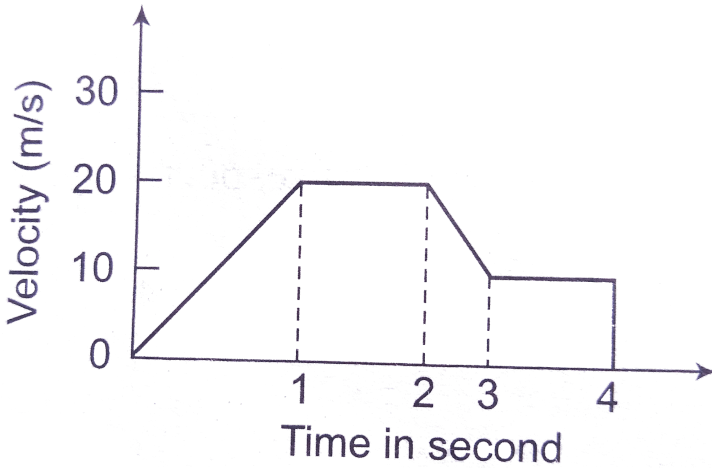

- A. 60 m
- B. 55 m
- C. 25 m
- D. 30 m

Answer: B

7. A lift is going up. The variation in the speed of the lift is as given in the graph in the graph. What is the height to which the lift takes the passengers ?

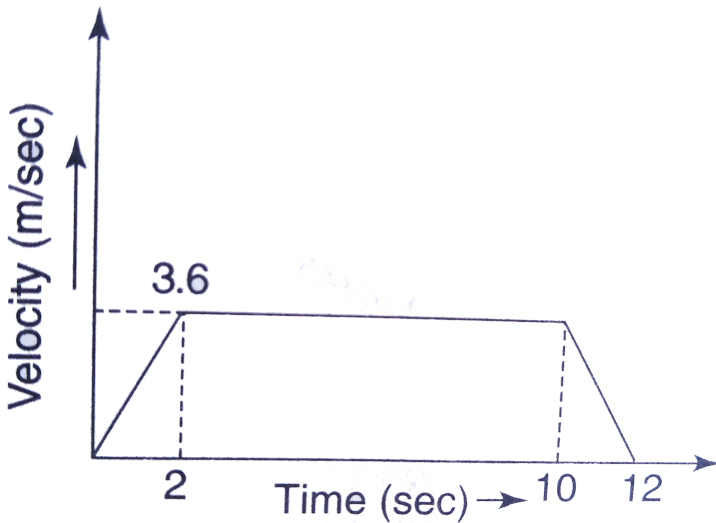

- A. $3.6m$
- B. $28.8m$
- C. $36.0m$

D. Cannot be calculated from the above graph

Answer: C

 Watch Video Solution

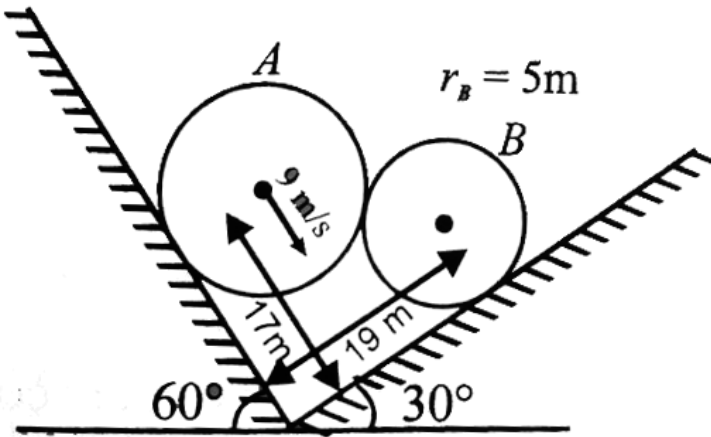

8.

System is shown in the figure. Velocity of sphere A is $9 \frac{\text{m}}{\text{s}}$. Find

the speed of sphere B.

A. 8 m , 16 m

B. 16 m , 32 m

C. 16m, 16m

D. 8m, 18m

Answer: A



[Watch Video Solution](#)

9. The $x-t$ equation is given as $x = 2t + 1$. The corresponding $v-t$ graph is

A. a straight line passing through origin

B. a straight line not passing through origin

C. a parabola

D. None of the above

Answer: B



[Watch Video Solution](#)

10. Which of the following graph correctly represents velocity-time relationship for a particle released from rest to fall freely under gravity ?

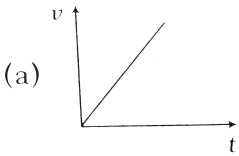

A.

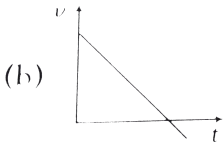

B.

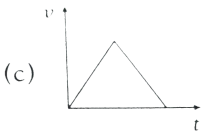

C.

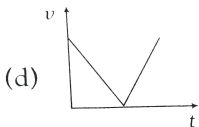

D.

Answer: A



11. A particle is thrown vertically upwards with a velocity v . It returns to the ground in time T . which of the following graphs correctly represents the motion ?

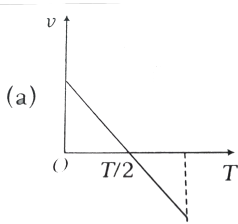

A.

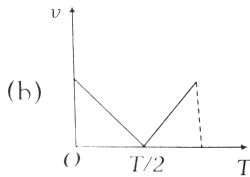

B.

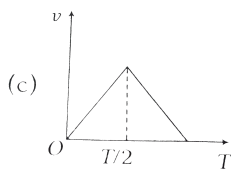

C.

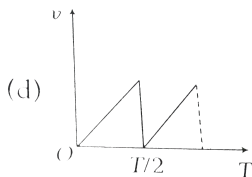

D.

Answer: A



12. The velocity time graph of a body is shown in fig. it indicates that :

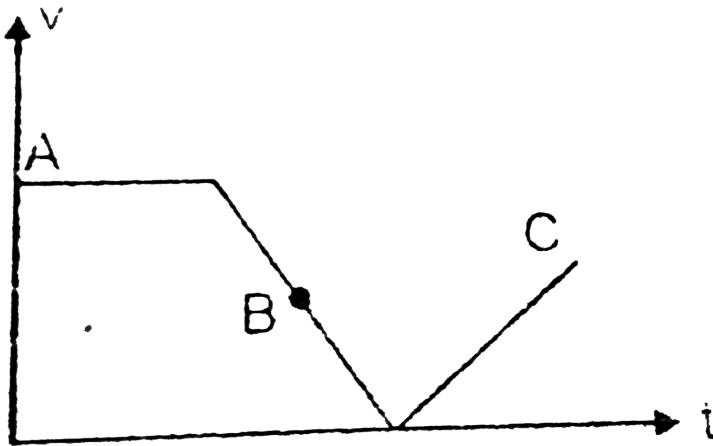

- A. the is zero
- B. there is at force towards motion
- C. there is a force which opposes motion
- D. there is only gravitational force

Answer: C

 Watch Video Solution

13. The velocity - time graph is shown in the figure, for a particle.

The acceleration of particle is

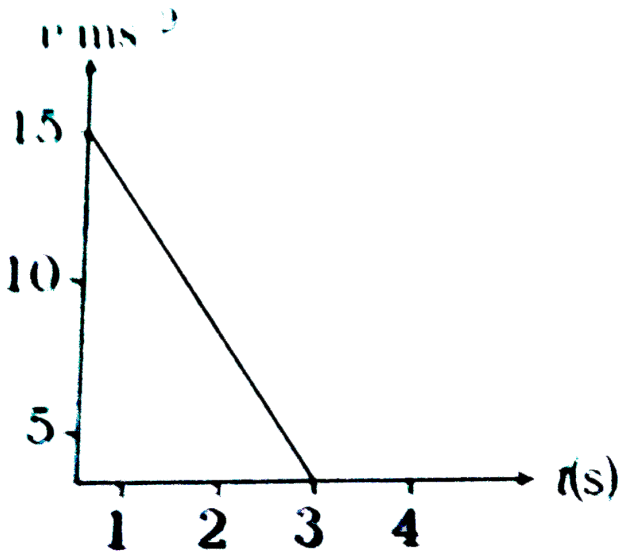

A. $22.5ms^{-2}$

B. $5ms^{-2}$

C. $-5ms^{-2}$

D. $-3ms^{-2}$

Answer: C

 Watch Video Solution

14. The v-t plot of a moving object is shown in the figure. The average velocity of the object during the first 10 s is

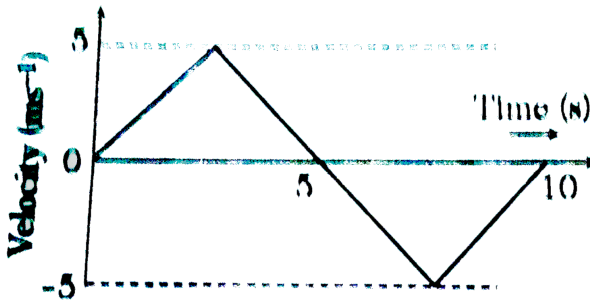

A. zero

B. $2.5ms^{-1}$

C. $5ms^{-1}$

D. 2ms^{-1}

Answer: A

 Watch Video Solution

15. Which of the following graphs cannot possibly represent one dimensional motion of a particle?

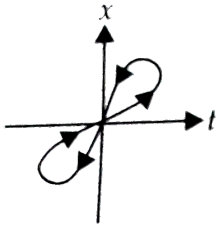

(i)

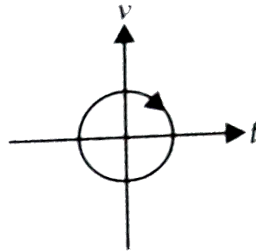

(ii)

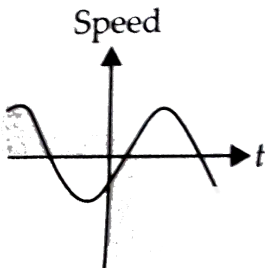

(iii)

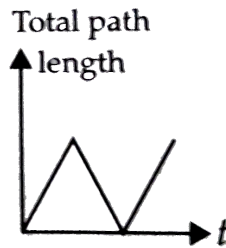

(iv)

A. I and II

B. II and III

C. II and IV

D. All four

Answer: D

 [Watch Video Solution](#)

16. If the velocity v of particle moving along a straight line decreases linearly with its displacement s from $20ms^{-1}$ to a value approaching zero at $s = 30$ m, then acceleration of the particle at

$v = 10ms^{-2}(-1)$ is

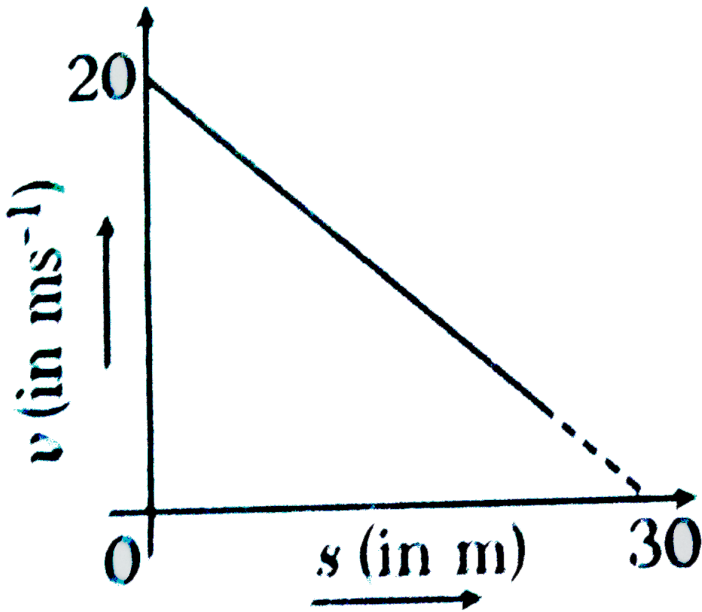

- A. $\frac{2}{3}ms^{-2}$
- B. $-\frac{2}{3}ms^{-2}$
- C. $\frac{20}{3}ms^{-2}$
- D. $-\frac{20}{3}ms^{-2}$

Answer: D



Watch Video Solution

17. v^2 versus s -graph of a particle moving in a straight line is shown in the figure. From the graph some conclusions are drawn.

State which statement is wrong ?

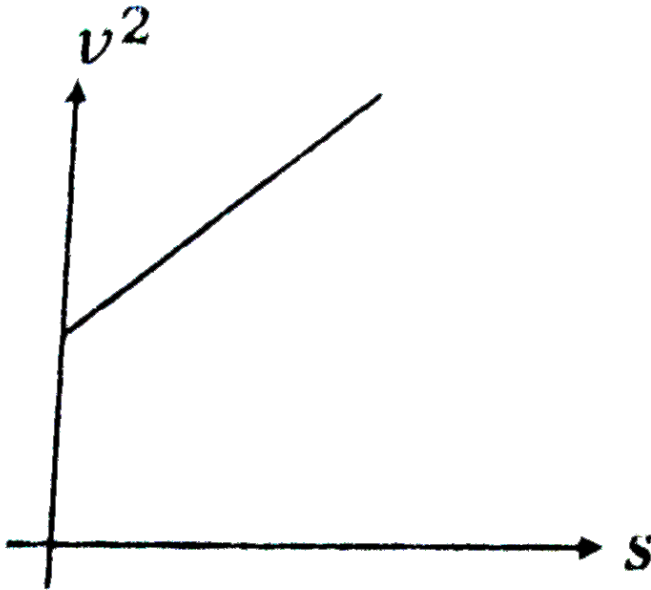

- A. The given graph shown a uniformly accelerated motion
- B. Initial velocity of particle is zero
- C. Corresponding s - t graph will be a parabola
- D. None of the above

Answer: B

 Watch Video Solution

18. A graph between the square of the velocity of a particle and the distance s moved by the particle is shown in the figure. The acceleration of the particle is

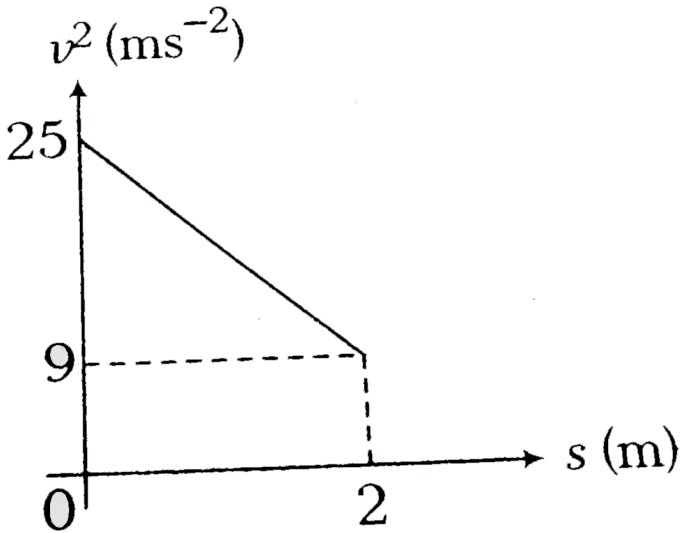

A. -8ms^{-2}

B. -4ms^{-2}

C. -16m.s^{-2}

D. None of these

Answer: B

 [Watch Video Solution](#)

19. The area under acceleration-time graph represents the

A. distance travelled

B. change in acceleration

C. force acting

D. change in velocity

Answer: D

 [Watch Video Solution](#)

20. A particle starts from rest at $t = 0$ and undergoes an acceleration (a) in ms^{-2} with time (t) in seconds which is shown in Fig. 2 (DF) .16 . Which one of the following plots represents velocity (v) (in ms^{-1}) versus time (in seconds) ?

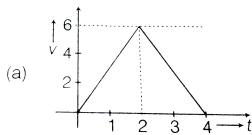
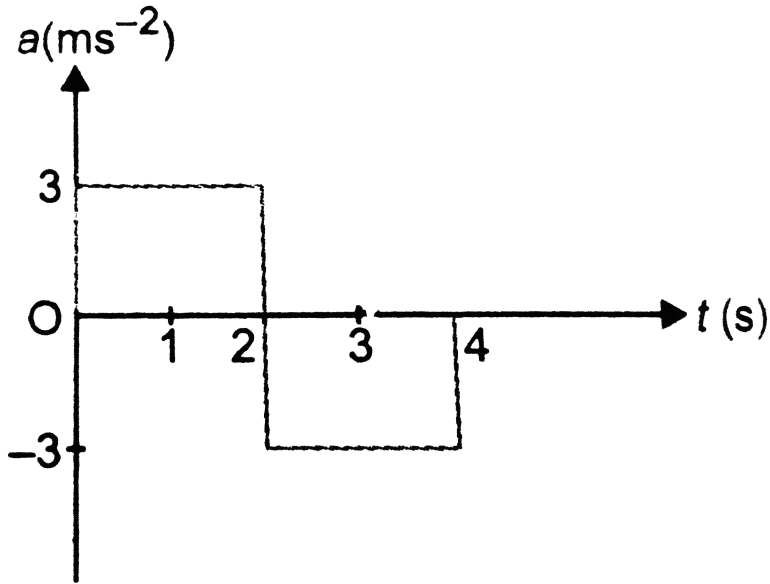

A.

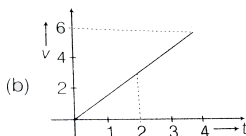

B.

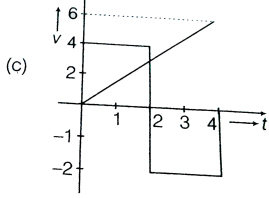

C.

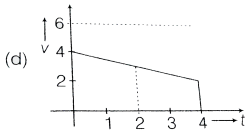

D.

Answer: A

 [Watch Video Solution](#)

Check point 3.7

1. A train is moving due east and a car is moving due north with equal speeds. A passenger in the train finds that the car is moving towards

A. East-North direction

B. West-North direction

C. South-East direction

D. None of these

Answer: B



Watch Video Solution

2. A 100 m long train crosses a man travelling at 5kmh^{-1} , in opposite direction, in 7.2s then the velocity of train is

A. 40ms^{-1}

B. 25ms^{-1}

C. 20ms^{-1}

D. 45ms^{-1}

Answer: D

 [Watch Video Solution](#)

3. Two bodies are held separated by $9.8m$ vertically one above the other. They are released simultaneously to fall freely under gravity. After 2 s the relative distance between them is

A. $4.9m$

B. $19.6m$

C. $9.8m$

D. $392m$

Answer: C

 [Watch Video Solution](#)

4. A particle (A) moves due North at 3kmh^{-1} and another particle (B) moves due West at 4kmh^{-1} . The relative velocity of A with respect to B is ($\tan 37^\circ = 3/4$)

- A. 5kmh^{-1} , 37° North of East
- B. 5kmh^{-1} , 37° East of North
- C. $5\sqrt{2}\text{kmh}^{-1}$, 53° East of North
- D. $5\sqrt{2}\text{kmh}^{-1}$, 53° North of East

Answer: B



[Watch Video Solution](#)

5. A man standing on a road has to hold his umbrella at 30° with the vertical to keep the rain away. He then starts running at 10 km/h . He finds that raindrops are hitting his

head vertically. Find the speed of raindrops with respect to a. the road, b. the moving man.

A. $10\sqrt{3}kmh^{-1}$

B. $20kmh^{-1}$

C. $\frac{20}{\sqrt{3}}kmh^{-1}$

D. $\frac{10}{\sqrt{3}}kmh^{-1}$

Answer: B



[Watch Video Solution](#)

6. A stationary man observes that the rain is falling vertically downwards. When he starts running a velocity of $12kmh^{-1}$, he observes that the rain is falling at an angle 60° with the vertical.

The actual velocity of rain is

A. $12\sqrt{3}kmh^{-1}$

B. $6\sqrt{3}kmh^{-1}$

C. $4\sqrt{3}kmh^{-1}$

D. $2\sqrt{3}kmh^{-1}$

Answer: C

 [Watch Video Solution](#)

7. A boy is running on the plane road with velocity v with a long hollow tube in his hand. The water is falling vertically downwards with velocity u . At what angle to the vertical, he must inclined the tube the water drops enter it without touching its sides ?

A. $\tan^{-1}\left(\frac{v}{u}\right)$

B. $\sin^{-1}\left(\frac{v}{u}\right)$

C. $\tan^{-1}\left(\frac{u}{v}\right)$

D. $\cos^{-1}\left(\frac{v}{u}\right)$

Answer: A

 [Watch Video Solution](#)

8. The width of river is 1 km. The velocity of boat is 5 km/hr. The boat covered the width of river with shortest possible path in 15 min. Then the velocity of river stream is:

A. $4.5kmh^{-1}$

B. $4kmh^{-1}$

C. $.5kmh^{-1}$

D. $3kmh^{-1}$

Answer: D



Watch Video Solution

9. A particle of mass m moving in the x direction with speed $2v$ is hit by another particle of mass $2m$ moving in the y direction with speed v . If the collision is perfectly inelastic, the percentage loss in the energy during the collision is close to

- A. $\sqrt{2}v$ towards South-West
- B. $\sqrt{2}v$ towards North-West
- C. $\sqrt{2}v$ towards South-East
- D. v towards North-East

Answer: B



Watch Video Solution

10. A river is flowing from west to east at a speed of $5m/s$. A man on the south bank of the river capable of swimming at $10m/s$ in a still water wants to swim, across the river in a shortest time. He should swim in a direction

- A. due North
- B. 30° East of North
- C. 30° West of North
- D. 60° East of North

Answer: A



[Watch Video Solution](#)

11. A man can swim at the rate of $5kmh^{-1}$ in still water. A. One km wide river flows at the rate of $3kmh^{-1}$. The man wishes to swim

across the river directly opposite to the starting point. How much time will be take to cross the river

A. 127°

B. 143°

C. 120°

D. 150°

Answer: A



[Watch Video Solution](#)

12. Given $|V_{br}| = 4m/s =$ magnitude of velocity of boatman with respect to river, $v_r = 2m/s$ in the direction shown. Boatman wants to reach from point A to point B. At what angle θ should he

row his boat ?

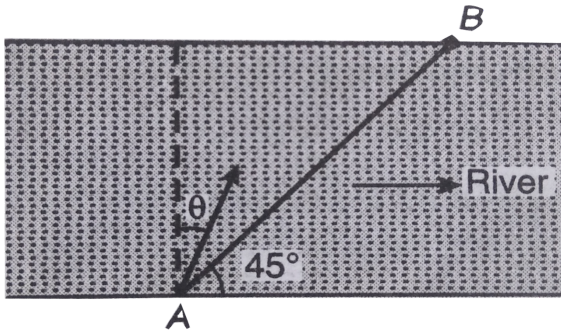

- A. u , 45° North-West
- B. u , 45° North-East
- C. $\frac{u}{\sqrt{2}}$, 45° North-West
- D. $\frac{u}{\sqrt{2}}$, 45° North-East

Answer: C



Watch Video Solution

13. Two trains are each 50 m long moving parallel towards each other at speeds 10ms^{-1} and 15ms^{-1} respectively, at what time will they pass each other ?

A. 8 s

B. 4 s

C. 2 s

D. 6 s

Answer: B



[Watch Video Solution](#)

14. A man is 25 m behind a bus, when bus starts accelerating at 2ms^{-2} and man starts moving with constant velocity of 10ms^{-1} .

Time taken by him to board the bus is

A. 2 s

B. 3 s

C. 4 s

D. 5 s

Answer: D



Watch Video Solution

15. A ball is dropped from the top of a building 100 m high. At the same instant another ball is thrown upwards with a velocity of 40ms^{-1} from the bottom of the building. The two balls will meet after.

A. 5 s

B. 2.5s

C. 2 s

D. 3 s

Answer: B



[Watch Video Solution](#)

(A) Taking it together

1. A boy walks to his school at a distance of 6 km with constant speed of 2.5 km h^{-1} and walks back with a constant speed of 4 km h^{-1} . His average speed for round trip expressed in km h^{-1} , is

A. $24/13$

B. $40/13$

C. 3

D. 1/2

Answer: B

 [Watch Video Solution](#)

2. A man walks on a straight road from his home to market 2.5 km away with speed of 5 km/h. Finding the market closed, he instantly turns and walks back with a speed of 7.5 km/h. What is the magnitude of average velocity and average speed of the man over the interval of time (i) 0 to 30 min (ii) 0 to 50 min (iii) 0 to 40 min ?

A. 5kmh^{-1}

B. $\frac{25}{4}\text{kmh}^{-1}$

C. $\frac{30}{4}\text{kmh}^{-1}$

D. $\frac{45}{8} kmh^{-1}$

Answer: C



Watch Video Solution

3. The distance travelled by a particle starting from rest and moving with an acceleration $\frac{4}{3} ms^{-2}$, in the third second is.

A. $\frac{10}{3} m$

B. $\frac{19}{3} / (m)$

C. 6 m

D. 4 m

Answer: A



Watch Video Solution

4. A particle is moving along x-direction with a constant acceleration a . The particle starts from $x = x_0$ position with initial velocity u . We can define the position of the particle with time by the relation

$$x = x_0 + ut + \frac{1}{2}at^2$$

plot the position of the particle in relation with time is following situations

- (i) If initial position of the particle is on negativ x-axis, initial velocity is positive and acceleration is negative.
- (ii) If initial position is positive, initial velocity is negative and acceleration is positive.

A. 12

B. 9

C. 10

D. 1.8

Answer: B



Watch Video Solution

5. A particle moves along x-axis as $x = 4(t - 2) + a(t - 2)^2$

Which of the following is true?

- A. The initial velocity of particle is 4
- B. The acceleration of particle is $2a$
- C. The particle is at origin at $t = 0$
- D. None of the above

Answer: B



Watch Video Solution

6. A car moving with a velocity of 10m/s can be stopped by the application of a constant force F In a distance of 20m . If the velocity of the car is 30m/s . It can be stopped by this force in

A. $\frac{20}{3}\text{m}$

B. 20 m

C. 60 m

D. 180 m

Answer: D



Watch Video Solution

7. A vehicle travels half the distance (L) with speed V_1 and the other half with speed V_2 , then its average speed is .

A. $\frac{v_1 + v_2}{2}$

B. $\frac{2v_1 + v_2}{v_1 + v_2}$

C. $\frac{2v_1v_2}{v_1 + v_2}$

D. $\frac{L(v_1 + v_2)}{v_1v_2}$

Answer: C



Watch Video Solution

8. The x and y coordinates of a particle at any time t are given by $x = 7t + 4t^2$ and $y = 5t$, where x and t is seconds. The acceleration of particle at $t = 5s$ is

A. zero

B. $8ms^{-2}$

C. $20ms^{-2}$

D. 40m.s^{-2}

Answer: b



Watch Video Solution

9. A body A starts from rest with an acceleration a_1 . After 2 seconds, another body B starts from rest with an acceleration a_2 . If they travel equal distances in the 5^{th} seconds, after the start of A, then the ratio $a_1 : a_2$ is equal to

A. 5 : 9

B. 5 : 7

C. 9 : 5

D. 9 : 7

Answer: A



10. Figure given shows the distance - time graph of the motion of a car. It follows from the graph that the car is

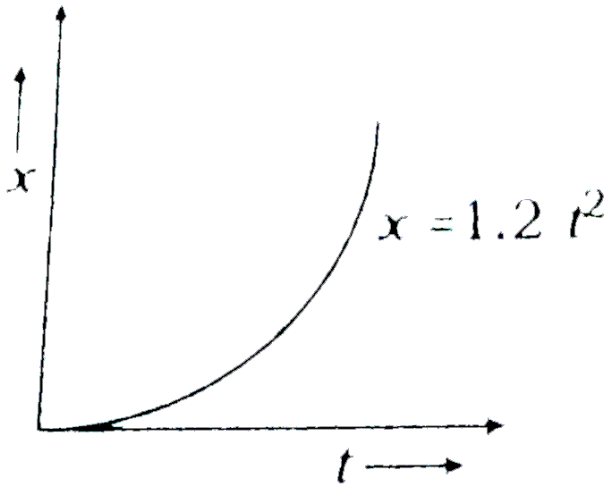

- A. at rest
- B. in uniform motion
- C. in non-uniform acceleration
- D. uniformly accelerated

Answer: D

 Watch Video Solution

11. Which of the following speed - time ($v - t$) graph is physically possible ?

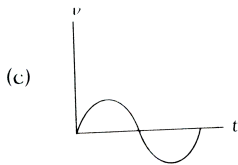
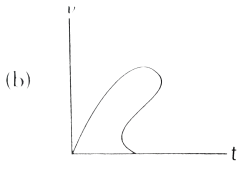
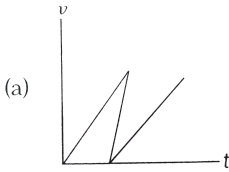

D. All of these

Answer: C



12. The displacement (x)-time (t) graph of a particle is shown in figure. Which of the following is correct ?

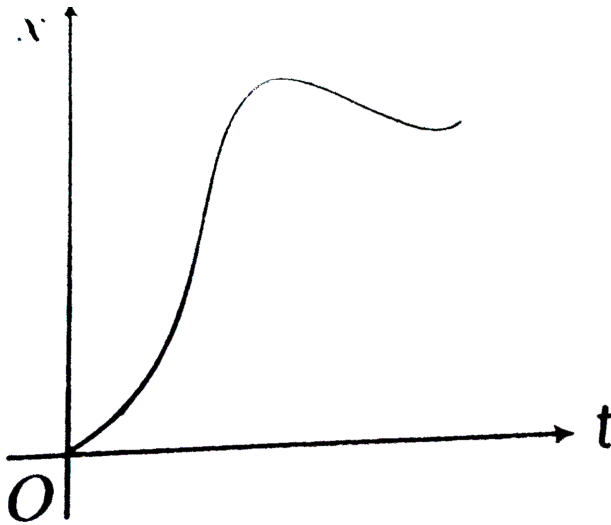

- A. Particle starts with zero velocity and variable acceleration
- B. Particle starts with non-zero velocity and variable acceleration
- C. Particle starts with zero velocity and uniform acceleration

D. Particle starts with non-zero velocity and uniform acceleration

Answer: A

 [Watch Video Solution](#)

13. The velocity of body is given as $v = 20 + 0.1t^2$. The body is undergoing

- A. uniform acceleration
- B. Uniform retardation
- C. Non-uniform acceleration
- D. Zero acceleration

Answer: C

 [Watch Video Solution](#)

14. A particle shows distance-time curve as given in this figure. The maximum instantaneous velocity of the particle is around the point.

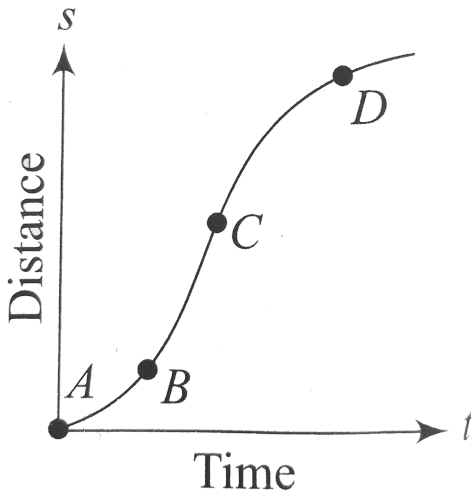

(a) B (b) C (c) D (d) A

A. A

B. B

C. C

D. D

Answer: C

 Watch Video Solution

15. The displacement-time graph of a moving particle is as shown in the figure. The instantaneous velocity of the particle is negative at the point

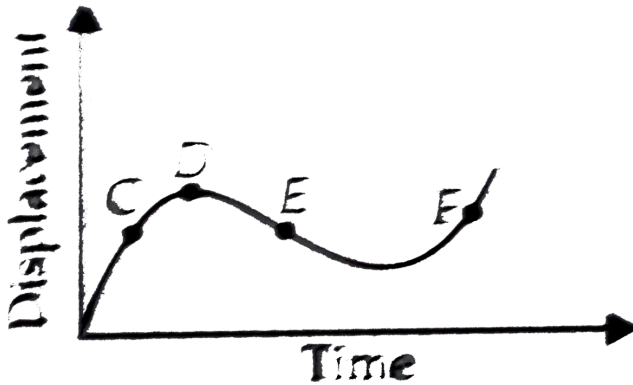

A. E

B. F

C. C

D. D

Answer: A

 [Watch Video Solution](#)

16. The velocity v of a particle as a function of its position (x) is expressed as $v = \sqrt{c_1 - c_2x}$, where c_1 and c_2 are positive constants. The acceleration of the particle is

A. c_2

B. $-\frac{c_2}{2}$

C. $c_1 - c_2$

D. $\frac{c_1 + c_2}{2}$

Answer: B

 [Watch Video Solution](#)

17. A person walks up a stalled 15 m long escalator in 90 s. When standing on the same escalator, now moving, the person is carried up in 60 s. How much time would it take that person to walk up the moving escalator? Does the answer depend on the length of the escalator?

A. 27 s

B. 50 s

C. 18 s

D. 36 s

Answer: D



[Watch Video Solution](#)

18. A car starts moving along a line, first with acceleration $a=5 \text{ ms}^{-2}$ starting from rest then uniformly and finally decelerating at the same rate a , comes to rest. The total time of motion is $\tau = 25 \text{ s}$. The average velocity during the time is equal to vt gt $=72 \text{ km/hr}$. How long does the partial move uniformly ?

A. 10 s

B. 12 s

C. 20 s

D. 15 s

Answer: D



Watch Video Solution

19. The displacement of a particle moving in a straight line depends on time as $x = \alpha t^3 + \beta t^2 + \gamma t + \delta$. The ratio of initial acceleration to its initial velocity depends

A. The particle never returns to its starting point

B. The particle comes to rest after time $\frac{2\alpha}{3\beta}$

C. The initial velocity of the particle is zero

D. The initial acceleration of the particle is zero

Answer: D



Watch Video Solution

20. A starts from rest, with uniform acceleration a . The acceleration of the body as function of time t is given by the

equation $a = pt$, where p is a constant, then the displacement of the particle in the time interval $t = 0$ to $t = t_1$ will be

A. $\frac{1}{2}pt_1^3$

B. $\frac{1}{3}pt_1^2$

C. $\frac{1}{2}pt_1^2$

D. $\frac{1}{2}pt_1^3$

Answer: D



[Watch Video Solution](#)

21. A ball is dropped on the floor from a height of 10m. It rebounds to a height of 2.5m. If the ball is in contact with the floor for 0.01sec, the average acceleration during contact is :
($g = 9.8m/s^2$)

A. $2414ms^{-2}$

B. $1735ms^{-2}$

C. $3120ms^{-2}$

D. $4105ms^{-2}$

Answer: A

 [Watch Video Solution](#)

22. Particle A is moving along X-axis. At time $t = 0$, it has velocity of $10ms^{-1}$ and acceleration $-4ms^{-2}$. Particle B has velocity of $20ms^{-1}$ and acceleration $-2ms^{-2}$. Initially both the particles are at origin. At time $t = 2$ distance between the particles are at origin. At time $t = 2$ s distance between the particles is

A. 24 m

B. 36 m

C. 20 m

D. 42 m

Answer: A



Watch Video Solution

23. At a metro station, a girl walks up a stationary escalator in time t_1 . If she remains stationary on the escalator, then the escalator take her up in time t_2 . The time taken by her to walk up on the moving escalator will be

A. $\frac{(t_1 + t_2)}{2}$

B. $\frac{t_1 t_2}{(t_2 - t_1)}$

C. $\frac{t_1 t_2}{(t_2 + t_1)}$

D. $t_1 - t_2$

Answer: C



[Watch Video Solution](#)

24. The displacement of a body along X-axis depends on time as

$\sqrt{x} = t + 1$. Then the velocity of body.

- A. increases with time
- B. decreases with time
- C. independent of time
- D. None of these

Answer: A



[Watch Video Solution](#)

25. A cyclist starts from the centre O of a circular park of radius 1 km. reaches the edge P of the park, then cycles along the circumference and returns to the centre along QO as shown in the figure.

IF the rounds trip takes ten minutes, the net displacement and average speed of the cyclist (in metre and kilometre per hour) is

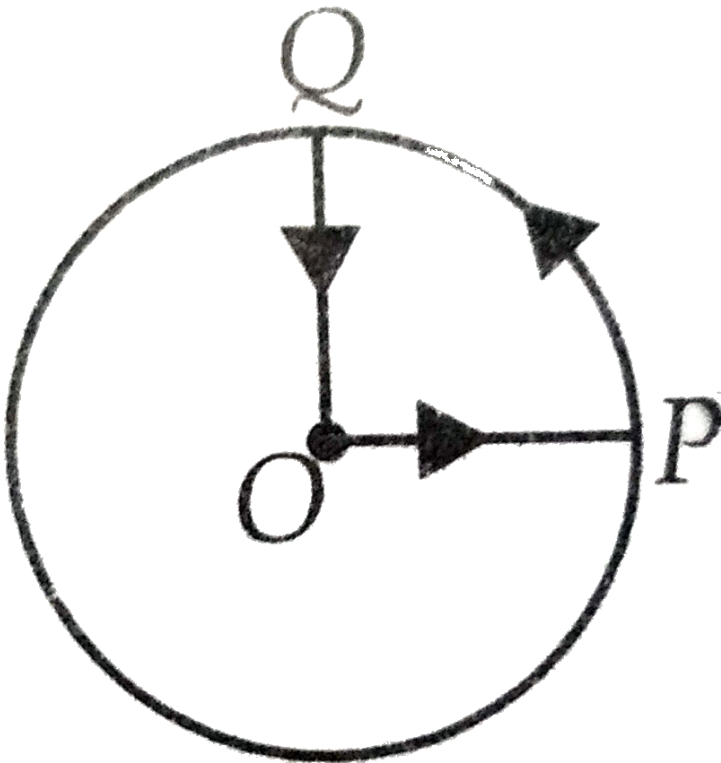

A. 0, 1

B. $\frac{\pi + 4}{2}, 0$

C. 21.4, $\frac{\pi + 4}{2}$

D. 0, 21.4

Answer: D



Watch Video Solution

26. A particle moves along a straight line OX. At a time t (in second), the distance x (in metre) of the particle from O is given by

$$x = 40 + 12t - t^3$$

How long would the particle travel before coming to rest ?

A. 24m

B. 40m

C. 56m

D. 16m

Answer: C



Watch Video Solution

27. Two boys are standing at the ends A and B of a ground where $AB = a$. The boy at B starts running in a direction perpendicular to AB with velocity v_1 . The boy at A starts running simultaneously with velocity v and catches the other in a time t , where t is

A. $a / \sqrt{v^2 + v_1^2}$

B. $\sqrt{a^2 / (v^2 - v_1^2)}$

C. $a / (v - v_1)$

D. $a / (v + v_1)$

Answer: B

 [Watch Video Solution](#)

28. A bullet emerges from a barrel of length $1.2m$ with a speed of $640ms^{-1}$. Assuming constant acceleration, after the gun is fired is

A. $4m$

B. $40m$

C. $400\mu s$

D. $1s$

Answer: B

 [Watch Video Solution](#)

29. From the top of a tower, 80m high from the ground a stone is thrown in the horizontal direction with a velocity of $8ms^{-1}$. The stone reaches the ground after a time t and falls at a distance of d from the foot of the tower. Assuming $g = 10ms^{-2}$, the time t and distance d are given respectively by

A. 6s,64m

B. 6s,48m

C. 4s,32m

D. 4s,16m

Answer: C



Watch Video Solution

30. A boggy of uniformly moving train is suddenly detached from train and stops after covering some distance. The distance covered by the boggy and distance covered by the train in the same time has relation

- A. Both will be equal
- B. First will be half of second
- C. First will be $\frac{1}{4}$ of second
- D. No definite ratio

Answer: B



[Watch Video Solution](#)

31. A man is 45 m behind the bus when the bus starts acceleration from rest with acceleration $2.5 \frac{m}{s^2}$. With what minimum velocity

should man start running to catch the bus?

A. 12m.s^{-1}

B. 14m.s^{-1}

C. 15m.s^{-1}

D. 16m.s^{-1}

Answer: C



Watch Video Solution

32. A body moves for a total of nine second starting from rest with uniform acceleration and then with uniform retardation, which is twice the value of acceleration and then stop. The duration of uniform acceleration is

A. 3s

B. 4.5s

C. 5s

D. 6s

Answer: D



Watch Video Solution

33. A point initially at rest moves along x-axis. Its acceleration varies with time as $a = (6t + 5)m/s^2$. If it starts from origin, the distance covered in 2 s is:

A. 20m

B. 18m

C. 16m

D. 25m

Answer: B

 Watch Video Solution

34. The time taken by a block of wood (initially at rest) to slide down a smooth inclined plane 9.8 m long (angle of inclination is 30°) is

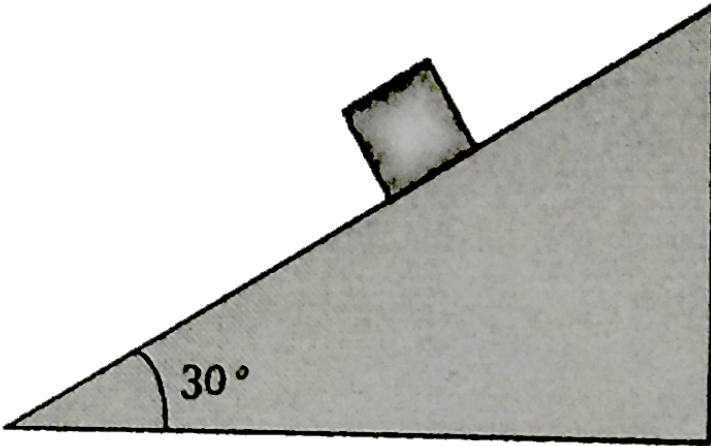

A. $\frac{1}{2} s$

B. 2 s

C. 4 s

D. 1 s

Answer: B



Watch Video Solution

35. A particle move a distance x in time t according to equation

$x = (t + 5)^{-1}$. The acceleration of particle is proportional to.

A. (velocity)^{3/2}

B. (distance)²

C. (distance)⁻²

D. (velocity)^{2/3}

Answer: A



Watch Video Solution

36. A ball is thrown upwards with a speed u from a height h above the ground. The time taken by the ball to hit the ground is

A. $\frac{v}{g} \sqrt{1 - \frac{2hg}{v^2}}$

B. $\frac{v}{g} \sqrt{1 + \frac{2hg}{v^2}}$

C. $\sqrt{1 + \frac{2hg}{v^2}}$

D. $\frac{v}{g} \left[1 + \sqrt{1 + \frac{2hg}{v^2}} \right]$

Answer: D



Watch Video Solution

37. The position of a particle along X-axis at time t is given by $x = 2 + t - 3t^2$. The displacement and the distance travelled in

the interval, $t = 0$ to $t = 1$ are respectively

A. 2, 2

B. -2 , 2.5

C. 0, 2

D. -2 , 2.1

Answer: D



[Watch Video Solution](#)

38. A ball falls freely from rest. The ratio of the distance travelled in first, second, third and fourth second is

A. $\sqrt{2} - 1$

B. $\sqrt{2} + 1$

C. $\sqrt{2}$

D. None of these

Answer: B

 [Watch Video Solution](#)

39. What is nature of trajectory of a particle having a uniformly accelerated motion in a plane?

A. $x = \sqrt{\frac{t+a}{b}}$

B. $x = \frac{t+a}{b}$

C. $t = \sqrt{\frac{x+a}{b}}$

D. $x = \sqrt{t+a}$

Answer: C

 [Watch Video Solution](#)

40. A particle moves along a straight line. Its position at any instant is given by $x = 32t - \frac{8t^3}{3}$ where x is in metres and t in seconds. Find the acceleration of the particle at the instant when particle is at rest.

A. $-16ms^{-2}$

B. $-27.6ms^{-2}$

C. $32ms^{-2}$

D. $16ms^{-2}$

Answer: B



[Watch Video Solution](#)

41. A point moves in a straight line so its displacement x meter at time t second is given by $x^2 = 1 + t^2$. Its acceleration in ms^{-2} at

time t second is .

A. $1/x$

B. $1/x^3$

C. $-1/x^2$

D. $-1/x^3$

Answer: B



Watch Video Solution

42. The displacement x of a particle varies with time t as

$x = ae^{-\alpha t} + be^{\beta t}$. Where a, b, α and β positive constant.

The velocity of the particle will.

A. go on decreasing with time

B. be independent of α and β

C. drop to zero when $\alpha = \beta$

D. go on increasing with time

Answer: D

 [Watch Video Solution](#)

43. Galileo's law of odd number: The distances traversed, during equal intervals of time, by a body falling from rest, stand to one another in the same ratio as the odd number beginning with unity [namely, 1 : 3 : 5 : 7...]. Prove it.

A. 1 : 3 : 5 : 7 : 9 : ...

B. 2 : 4 : 6 : 8 : 10 : ...

C. 1 : 4 : 7 : 10 : 13 : ...

D. None of the above

Answer: A

 Watch Video Solution

44. A particle starting from rest. Its acceleration (a) versus time (t) is as shown in the figure.

The maximum speed of the particle will be.

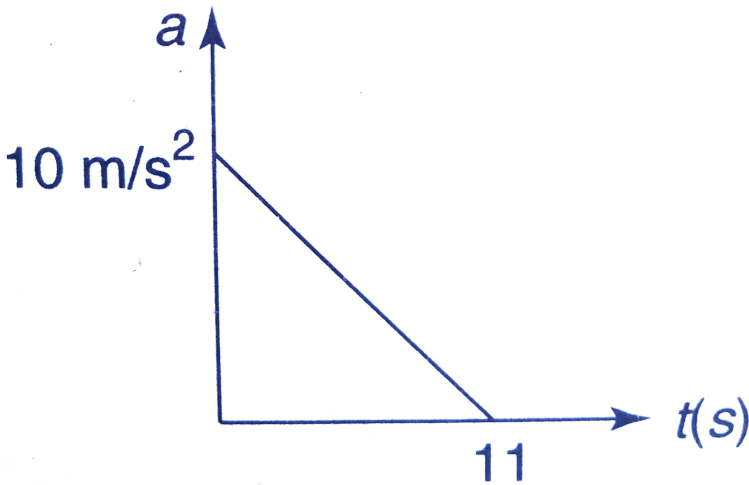

A. 110 m.s^{-1}

B. 55 m.s^{-1}

C. 550ms^{-1}

D. 660ms^{-1}

Answer: B

 [Watch Video Solution](#)

45. The acceleration (a)-time(t) graph for a particle moving along a straight from rest is shown in figur. Which of the following

graph is the best representation of its velocity (v) with time (t) ?

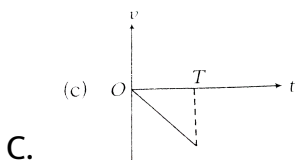
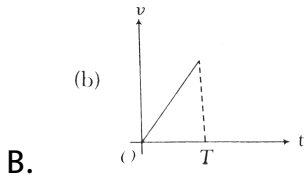
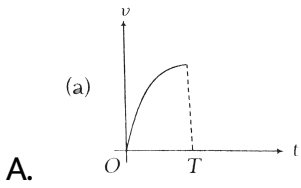
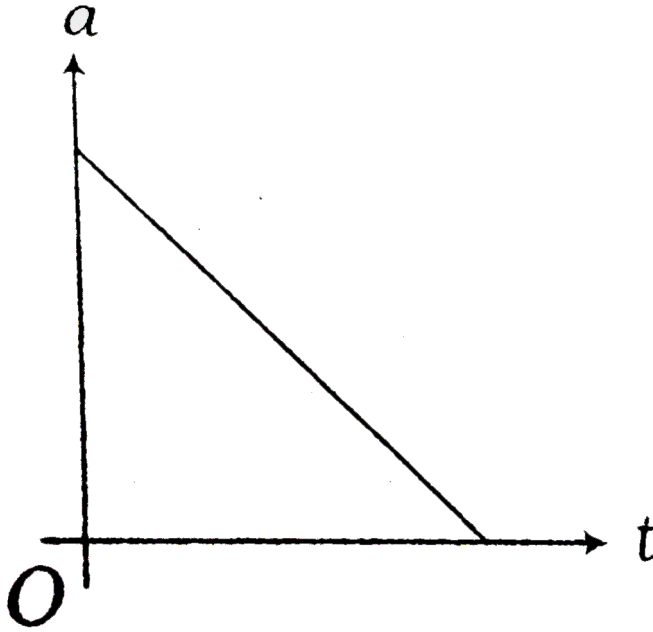

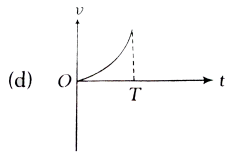

D.

Answer: A

 [Watch Video Solution](#)

46. A particle moving with uniform acceleration has average velocities ν_1 , ν_2 and ν_3 over the successive intervals of time t_1 , t_2 and t_3 respectively. The value of $\frac{\nu_1 - \nu_2}{\nu_2 - \nu_3}$ will be

A. $(\nu_1 - \nu_2) : (\nu_2 - \nu_3) = (t_1 - t_2) : (t_2 + t_3)$

B. $(\nu_1 - \nu_2) : (\nu_2 - \nu_3) = (t_1 + t_2) : (t_2 + t_3)$

C. $(\nu_1 - \nu_2) : (\nu_2 - \nu_3) = (t_1 - t_2) : (t_1 - t_3)$

D. $(\nu_1 - \nu_2) : (\nu_2 - \nu_2 - \nu_3) = (t_1 - t_2) : (t_2 - t_3)$

Answer: B



Watch Video Solution

47. The velocity-time graph for a particle moving along X-axis is shown in the figure. The corresponding displacement-time graph is correctly shown by

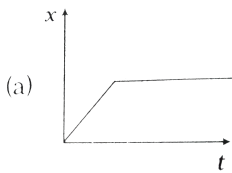
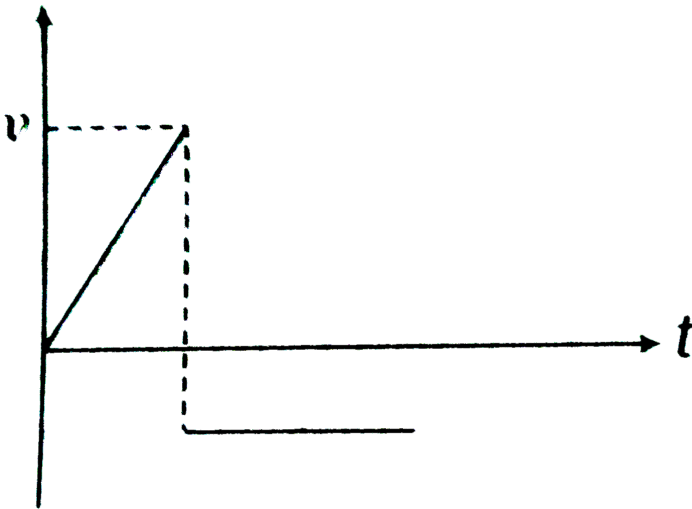

A.

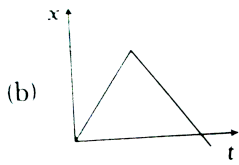

B.

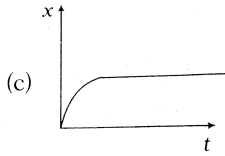

C.

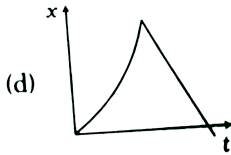

D.

Answer: D

 [Watch Video Solution](#)

48. The given graph shows the variation of velocity with displacement. Which one of the graph given below correctly

represents the variation of acceleration with displacement :-

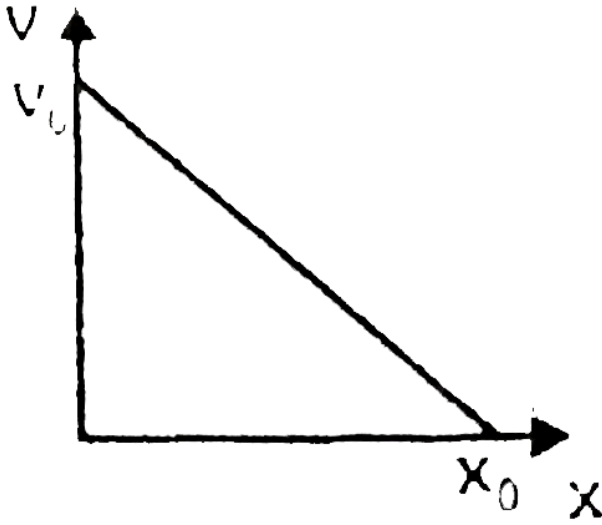

A.

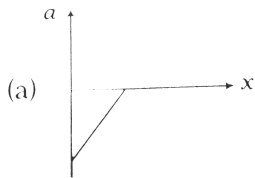

B.

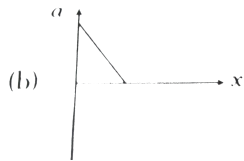

C.

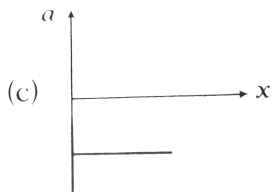

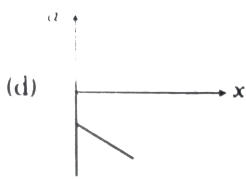

D.

Answer: A

 [Watch Video Solution](#)

49. The displacement x of a particle in a straight line motion is given by $x = 1 - t - t^2$. The correct representation of the motion is

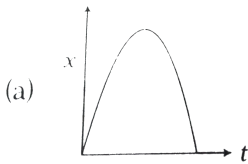

A.

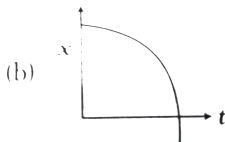

B.

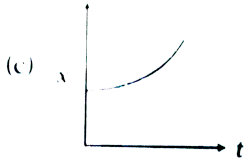

C.

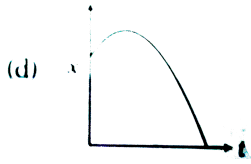

D.

Answer: B

 [Watch Video Solution](#)

50. The vertical of point above the ground is twice that of Q. A particle is projected downward with a speed of 5ms^{-1} from P and at the same time another particle is projected upward with the same speed from W. Both particle reach the ground simultaneously, then

A. $PQ = 30\text{ m}$

B. time of flight of stones = 3 s

C. Both (a) and (b) are correct

D. Both (a) and (b) are wrong

Answer: C

 [Watch Video Solution](#)

51. Among the four graphs, there is only one graph for which average velocity over the time interval $(0, T)$ can vanish for a suitably chosen T . Which one is it?

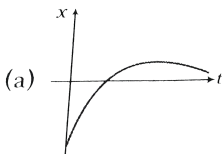

A.



B.

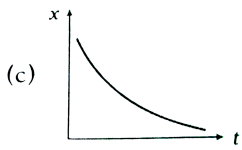

C.

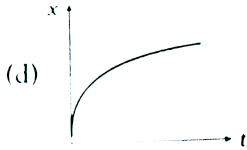

D.

Answer: B

 [Watch Video Solution](#)

52. A lift is coming from $8th$ floor and is just about to reach $4th$ floor. Taking ground floor as origin and positive direction upwards for all quantities, which one of the following is correct ?

A. $x < 0, v < 0, a > 0$

B. $x > 0, v < 0, a < 0$

C. $x > 0, v < 0, a < 0$

D. $x > 0, v > 0, a < 0$

Answer: A

 [Watch Video Solution](#)

53. In one dimensional motion, instantaneous speed v satisfies $(0 \leq v < v_0)$ then

- A. The displacement in time T must always take non-negative values
- B. The displacement x in time T satisfies $-v_0T < x < v_0T$
- C. The acceleration is always a non-negative number
- D. The motion has no turning points

Answer: B

 [Watch Video Solution](#)

54. The displacement of a particle is moving by $x = (t - 2)^2$ where x is in metres and t in second. The distance covered by the particle in first 4 seconds is.

- A. 4 m
- B. 8 m
- C. 12 m
- D. 16 m

Answer: B



Watch Video Solution

55. A driver having a definite reaction time is capable of stopping his car over a distance of 30 m on seeing a red traffic signal, when

the speed of the car is 72 km/hr and over a distance of 10 m when the speed is 36 km/hr. Find the distance over which he can stop the car if it were running at a speed of 54 km/hr. Assume that his reaction time and the deceleration of the car remains same in all the three cases.

- A. 293 m
- B. 111 m
- C. 91 m
- D. 182 m

Answer: A

 [Watch Video Solution](#)

56. The velocity (v) of a particle moving along X-axis varies with its position x as shown in figure. The acceleration (a) of particle

varies with position (x) as

v (ms^{-1})

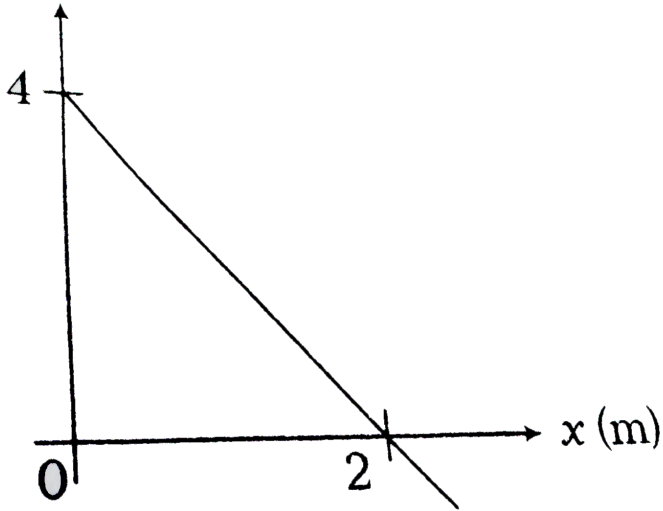

A. $a^2 = x + 3$

B. $a = 2x^2 + 4$

C. $2a = 3x + 5$

D. $a = 4x - 8$

Answer: D



Watch Video Solution

57. A car A moves along north with velocity 30 km/h and another car B moves along east with velocity 40 km/h. The relative velocity of A with respect to B is

- A. 50 km/h North - East
- B. 50 km/h North-West
- C. 50 km/h at angle $\tan^{-1}(3/4)$ North of West
- D. 50 km/h at angle $\tan^{-1}(3/4)$ West of North

Answer: C

 [Watch Video Solution](#)

58. Rain is falling vertically downward with velocity $4m/s$. A man is moving horizontally with velocity $3m/s$, the velocity of rain with respect to man is

A. 5 m/s at an angle $\tan^{-1}(4/3)$ with horizontal

B. 5 m/s at an angle $\tan^{-1}(3/4)$ with vertical

C. 5 m/s at an angle $\tan^{-1}(4/3)$ with vertical

D. Both (a) and (b)

Answer: D



Watch Video Solution

59. A ship is travelling due east at a speed of 15 km/h . Find the speed of a boat heading 30° east of north if it appears always due north from the ship.

A. 30 km/h

B. $\frac{15\sqrt{3}}{2}k\frac{m}{h}$

C. $10\sqrt{3}k\frac{m}{h}$

D. $20k \frac{m}{h}$

Answer: A

 [Watch Video Solution](#)

60. A man takes $3h$ to cover a certain distance along the flow and takes $6h$ to cover the same distance opposite to flow. In how much time, he will cross this distance in still water.

A. $3.5h$

B. $4 h$

C. $4.5h$

D. $5 h$

Answer: B

 [Watch Video Solution](#)

61. A river 500m wide is flowing at a rate of 4m/s . A boat is sailing at a velocity of 10m/s with respect to the water, in a direction perpendicular to the river. The time taken by the boat to reach the opposite bank

A. 30 s

B. 40 s

C. 50 s

D. 60 s

Answer: C



Watch Video Solution

62. A ball is dropped vertically from a height d above the ground. It hits the ground and bounces up vertically to a height $d/2$. Neglecting subsequent motion and air resistance, its velocity v varies with the height h above the ground as

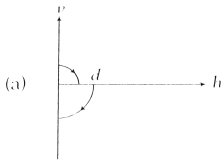

A.

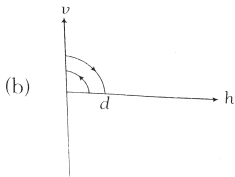

B.

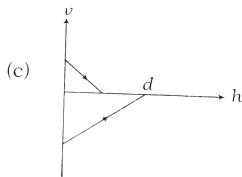

C.

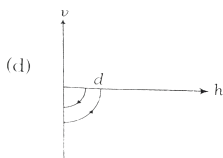

D.

Answer: A



Watch Video Solution

63. The driver of a train moving at a speed v_1 sights another train at a distance d , ahead of him moving in the same direction with a slower speed v_2 . He applies the brakes and gives a constant deceleration a to his train. Show that there will be no collision if $d > (v_1 - v_2)^2 / 2a$.

A. $d > \left(\frac{v_1 - v_2}{2a} \right)$

B. $d < \frac{(v_1 - v_2)^2}{2a}$

C. $d > \frac{(v_1 - v_2)^2}{2a}$

D. None of these

Answer: C



Watch Video Solution

64. The width of river is 1 km. The velocity of boat is 5 km/hr. The boat covered the width of river with shortest possible path in 15 min. Then the velocity of river stream is:

- A. 1 km/h
- B. 3 km/h
- C. 4 km/h
- D. 5 km/h

Answer: B



Watch Video Solution

65. 

- $d < \frac{(v_1 - v_2)^2}{2a}$
- $d < \frac{v_1^2 - v_2^2}{2a}$

- $d > \frac{(v_1 - v_2)^2}{2a}$
- $d > \frac{v_1^2 - v_2^2}{2a}$

Answer: C



Watch Video Solution

66. Water drops fall at regular intervals from a tap 5 m above the ground. The third drop is leaving the tap, the instant the first drop touches the ground. How far above the ground is the second drop at that instant. ($g = 10ms^{-2}$)

- A. $2.50m$
- B. $3.75m$
- C. $4.00m$
- D. $1.25m$

Answer: B

 [Watch Video Solution](#)

67. A man in a lift ascending with an upward acceleration a throws a ball vertically upwards with a velocity v with respect to himself and catches it after t_1 seconds. After wards when the lift is descending with the same acceleration a acting downwards the man again throws the ball vertically upwards with the same velocity with respect to him and catches it after t_2 seconds?

A. 1

B. 2

C. $\frac{10}{7}$

D. $\frac{20}{7}$

Answer: D



Watch Video Solution

68. A particle moving along x-axis has acceleration f , at time t , given by $f = f_0 \left(1 - \frac{t}{T} \right)$, where f_0 and T are constants. The particle at $t = 0$ has zero velocity. In the time interval between $t = 0$ and the instant when $f = 0$, the particle's velocity (v_x) is

A. $\frac{1}{2} f_0 T$

B. $f_0 T$

C. $\frac{1}{2} f_0 T^2$

D. $f_0 T^{-2}$

Answer: A



Watch Video Solution

69. The position x of a particle w.r.t. time t along x -axis is given by a $x = 9t^2 - t^3$, where x is in metre and t in sec. What will be the position of this particle when it achieves maximum speed along the $+x$ direction ?

A. 24 m

B. 32 m

C. 54 m

D. 81 m

Answer: C



[Watch Video Solution](#)

70. Two particles P and Q simultaneously start moving from point A with velocities $15m/s$ and $20m/s$ respectively. The two

particles move with acceleration equal in magnitude but opposite in direction. When P overtakes Q at B then its velocity is 30 m/s . Find velocity of Q at point B (in m/s).

A. 30 m s^{-1}

B. 5 m s^{-1}

C. 20 m s^{-1}

D. 15 m s^{-1}

Answer: B



[Watch Video Solution](#)

71. A body dropped from top of a tower falls through 40 m during the last two seconds of its fall. The height of tower in m is ($g = 10\text{ m/s}^2$)`

A. 60

B. 45

C. 80

D. 50

Answer: B



Watch Video Solution

72. A small block slides without friction down an inclined plane starting from rest. Let S_n be the distance traveled from time

$t = n - 1$ to $t = n$. Then $\frac{S_n}{S_{n+1}}$ is:

A. $\frac{2n - 1}{2n}$

B. $\frac{2n + 1}{2n - 1}$

C. $\frac{2n - 1}{2n + 1}$

D. $\frac{2n}{2n + 1}$

Answer: C

 [Watch Video Solution](#)

73. A particle located at $x = 0$ at time $t = 0$, starts moving along with the positive x -direction with a velocity v that varies as $v = \alpha\sqrt{x}$. The displacement of the particle varies with time as

A. t

B. $t^{1/2}$

C. t^3

D. t^2

Answer: D

 [Watch Video Solution](#)

74. A body falls freely from the top of a tower. It covers 36% of the total height in the last second before striking the ground level.

The height of the tower is

- A. 50 m
- B. 75 m
- C. 100 m
- D. 125 m

Answer: D

 [Watch Video Solution](#)

75. An elevator car whose floor to ceiling distance is equal to $2.7m$ starts ascending with constant acceleration $1.2m/s^2$, 2 sec after

the start a bolt begins falling from the ceiling of the car. Answer

the following question ($g = 9.8m / s^2$)

The bolt's free fall time is

A. $\sqrt{\frac{2.7}{9.8}}s$

B. $\sqrt{\frac{5.4}{9.8}}s$

C. $\sqrt{\frac{5.4}{8.6}}s$

D. $\sqrt{\frac{5.4}{11}}s$

Answer: D



[Watch Video Solution](#)

(B) Meical entrance special format questions (Assertion and reason)

1. Assertion : Acceleration of a moving particle can change its direction without any change in direction of velocity.

Reason : If the direction of change in velocity vector changes, the direction of acceleration vector also changes.

- A. If both Assertion and Reason are correct and Reason is the correct explanation of assertion.
- B. If both Assertion and Reason are correct but Reason is not the correct explanation of Assertion.
- C. If Assertion is true but Reason is false.
- D. If Assertion is false but Reason is true.

Answer: D



Watch Video Solution

2. Assertion : An object may have varying speed without having varying velocity.

Reason : If the velocity is zero at an instant, the acceleration may not be zero at that instant.

- A. If both Assertion and Reason are correct and Reason is the correct explanation of assertion.
- B. If both Assertion and Reason are correct but Reason is not the correct explanation of Assertion.
- C. If Assertion is true but Reason is false.
- D. If Assertion is false but Reason is true.

Answer: D



[Watch Video Solution](#)

3. Assertion : Magnitude of average velocity is equal to average speed, if velocity is constant.

Reason : If velocity is constant, then there is no change in the direction of motion.

- A. If both Assertion and Reason are correct and Reason is the correct explanation of assertion.
- B. If both Assertion and Reason are correct but Reason is not the correct explanation of Assertion.
- C. If Assertion is true but Reason is false.
- D. If Assertion is false but Reason is true.

Answer: B

 [Watch Video Solution](#)

4. Assertion : In the equation, $s = u + at - \frac{1}{2}a$ where, s is the distance travelled by uniformly accelerated body in t th second.

Reason : The above equation is dimensionally incorrect.

- A. If both Assertion and Reason are correct and Reason is the correct explanation of assertion.
- B. If both Assertion and Reason are correct but Reason is not the correct explanation of Assertion.
- C. If Assertion is true but Reason is false.
- D. If Assertion is false but Reason is true.

Answer: B

 [Watch Video Solution](#)

5. Assertion : A body is momentarily at rest at the instant it reverses the direction.

Reason : A body cannot have acceleration if its velocity is zero at a given instant of time.

- A. If both Assertion and Reason are correct and Reason is the correct explanation of assertion.
- B. If both Assertion and Reason are correct but Reason is not the correct explanation of Assertion.
- C. If Assertion is true but Reason is false.
- D. If Assertion is false but Reason is true.

Answer: C

 [Watch Video Solution](#)

6. Assertion : The average velocity of a particle having initial and final velocity v_1 and v_2 is $v_1 + v_2 / 2$.

Reason : If r_1 and r_2 be the initial and final displacement in time t ,

then $v_{av} = \frac{r_1 - r_2}{t}$.

- A. If both Assertion and Reason are correct and Reason is the correct explanation of assertion.
- B. If both Assertion and Reason are correct but Reason is not the correct explanation of Assertion.
- C. If Assertion is true but Reason is false.
- D. If Assertion is false but Reason is true.

Answer: D



[Watch Video Solution](#)

7. Assertion : The $v - t$ graph perpendicular to time axis is not possible in particle.

Reason : Infinite acceleration cannot be realised in particle.

- A. If both Assertion and Reason are correct and Reason is the correct explanation of assertion.
- B. If both Assertion and Reason are correct but Reason is not the correct explanation of Assertion.
- C. If Assertion is true but Reason is false.
- D. If Assertion is false but Reason is true.

Answer: A

 [Watch Video Solution](#)

8. Assertion : If velocity - time equation of a particle moving in a straight line is quadratic in time, then displacement - time equation cannot be linear.

Reason : If displacement - time is quadratic in time, then velocity - time is linear.

- A. If both Assertion and Reason are correct and Reason is the correct explanation of assertion.
- B. If both Assertion and Reason are correct but Reason is not the correct explanation of Assertion.
- C. If Assertion is true but Reason is false.
- D. If Assertion is false but Reason is true.

Answer: B

 [Watch Video Solution](#)

9. Assertion : Distance between two particles moving with constant velocities always remains constant.

Reason : In the above case, relative motion between them is uniform.

- A. If both Assertion and Reason are correct and Reason is the correct explanation of assertion.
- B. If both Assertion and Reason are correct but Reason is not the correct explanation of Assertion.
- C. If Assertion is true but Reason is false.
- D. If Assertion is false but Reason is true.

Answer: D



Watch Video Solution

10. Assertion : In the s - t diagram as shown in figure, the body starts moving in positive direction but not from $s = 0$.

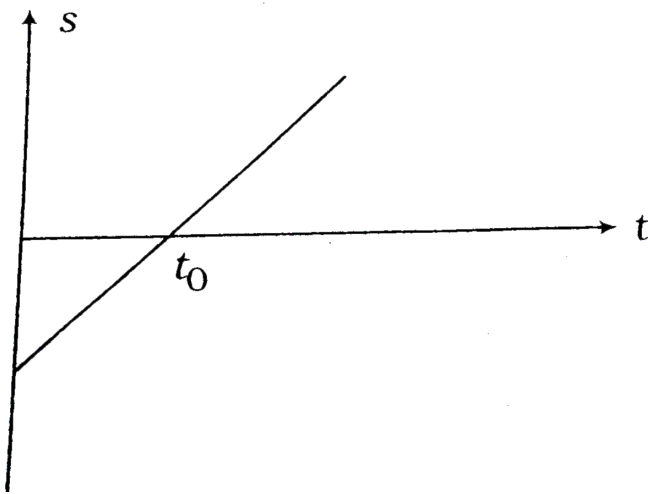

Reason : At $t = t_0$, velocity of body changes its direction of motion.

- A. If both Assertion and Reason are correct and Reason is the correct explanation of assertion.
- B. If both Assertion and Reason are correct but Reason is not the correct explanation of Assertion.
- C. If Assertion is true but Reason is false.
- D. If Assertion is false but Reason is true.

Answer: C



11. Assertion : In the s - t graph as shown in figure, velocity of particle is negative and acceleration is positive.

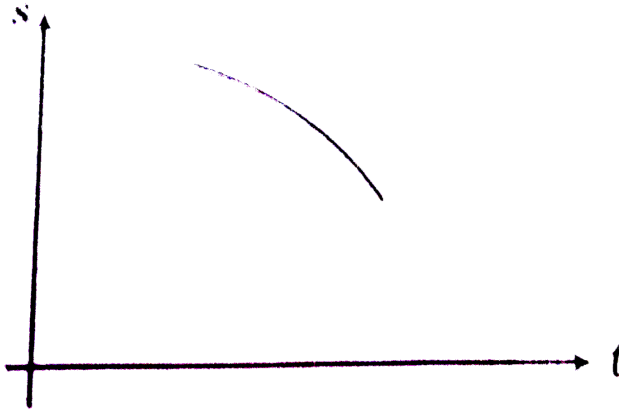

Reason : Slope of s - t graph is negative and increasing in magnitude.

- A. If both Assertion and Reason are correct and Reason is the correct explanation of assertion.
- B. If both Assertion and Reason are correct but Reason is not the correct explanation of Assertion.

C. If Assertion is true but Reason is false.

D. If Assertion is false but Reason is true.

Answer: D

 [Watch Video Solution](#)

12. Assertion : A body of mass 4 kg has an initial velocity $5\hat{i}ms^{-1}$.

It is subjected to a force of $4\hat{j}N$. The displacement of body from origin after 4 s will be $21.5m$.

Reason : The equation $v = u + at$ can be applied to obtain v if a is constant.

A. If both Assertion and Reason are correct and Reason is the correct explanation of assertion.

B. If both Assertion and Reason are correct but Reason is not the correct explanation of Assertion.

C. If Assertion is true but Reason is false.

D. If Assertion is false but Reason is true.

Answer: B

 [Watch Video Solution](#)

13. Assertion : Particle A is moving Eastwards and particle B Northwards with same speed. Then, velocity of A with respect to B is in South-East direction.

Reason : Relative velocity between them is zero as their speeds are same.

- A. If both Assertion and Reason are correct and Reason is the correct explanation of assertion.
- B. If both Assertion and Reason are correct but Reason is not the correct explanation of Assertion.
- C. If Assertion is true but Reason is false.
- D. If Assertion is false but Reason is true.

Answer: C

 [Watch Video Solution](#)

14. Assertion : On a curved path, average speed of a particle can never be equal to average velocity.

Reason : Average speed is total distance travelled divided by total time. Whereas average velocity is, final velocity plus initial velocity divided by two.

- A. If both Assertion and Reason are correct and Reason is the correct explanation of assertion.
- B. If both Assertion and Reason are correct but Reason is not the correct explanation of Assertion.
- C. If Assertion is true but Reason is false.
- D. If Assertion is false but Reason is true.

Answer: C

 [Watch Video Solution](#)

15. Assertion : If a particle is thrown upwards, then distance travelled in last second of upward journey is independent in last second of upward journey is independent of the velocity of projection.

Reason : In last second, distance travelled is $4.9m$. (Taken, $g = 9.8ms^{-2}$)

- A. If both Assertion and Reason are correct and Reason is the correct explanation of assertion.
- B. If both Assertion and Reason are correct but Reason is not the correct explanation of Assertion.
- C. If Assertion is true but Reason is false.
- D. If Assertion is false but Reason is true.

Answer: A

 [Watch Video Solution](#)

16. Assertion : If acceleration of a particle moving in a straight line varies as $a \propto t^n$, then $S \propto t^{n+2}$

Reason : If $a-t$ graph is a straight line, then $s-t$ graph may be a parabola.

- A. If both Assertion and Reason are correct and Reason is the correct explanation of assertion.
- B. If both Assertion and Reason are correct but Reason is not the correct explanation of Assertion.
- C. If Assertion is true but Reason is false.
- D. If Assertion is false but Reason is true.

Answer: B



[Watch Video Solution](#)

17. Assertion : A lift is ascending with decreasing speed means acceleration of lift is downwards.

Reason : A body always moves in the direction of its acceleration.

- A. If both Assertion and Reason are correct and Reason is the correct explanation of assertion.
- B. If both Assertion and Reason are correct but Reason is not the correct explanation of Assertion.
- C. If Assertion is true but Reason is false.
- D. If Assertion is false but Reason is true.

Answer: C

 [Watch Video Solution](#)

18. Assertion : A body is moving along a straight line such that its velocity varies with time as shown in figure. Magnitude of displacement of the body from $t = 0$ to $t = 12$ s is the same as the

distance travelled by it in the given time duration.

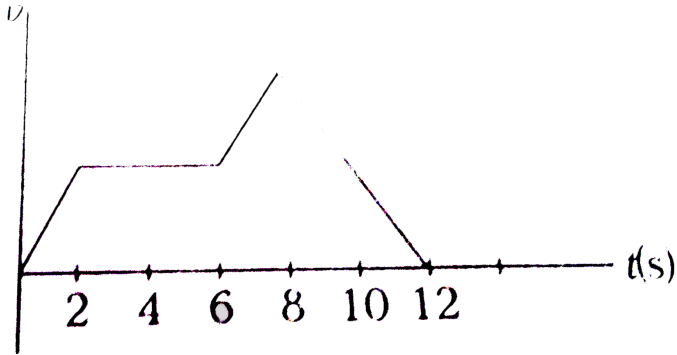

Reason : For unidirectional motion of a body,

$|\text{displacement}| = \text{distance}$

- A. If both Assertion and Reason are correct and Reason is the correct explanation of assertion.
- B. If both Assertion and Reason are correct but Reason is not the correct explanation of Assertion.
- C. If Assertion is true but Reason is false.
- D. If Assertion is false but Reason is true.

Answer: A



19. Assertion : In the $v - t$ diagram as shown in figure, average velocity between the interval $t = 0$ and $t = t_0$ is independent of t_0

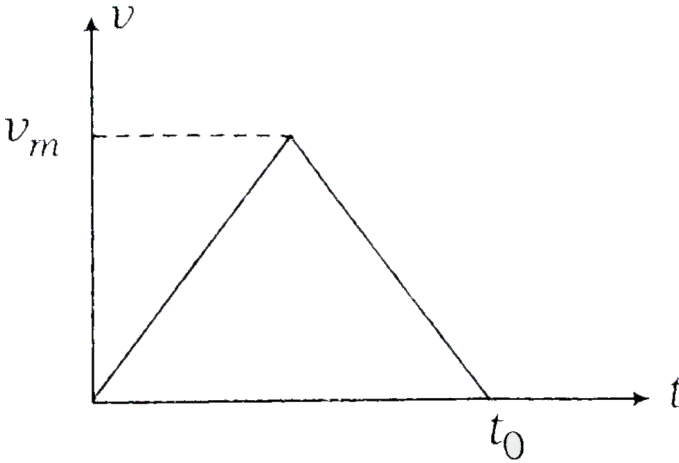

Reason : Average velocity in the given interval is $\frac{1}{2}v_m$.

A. If both Assertion and Reason are correct and Reason is the correct explanation of assertion.

B. If both Assertion and Reason are correct but Reason is not the correct explanation of Assertion.

C. If Assertion is true but Reason is false.

D. If Assertion is false but Reason is true.

Answer: A

 [Watch Video Solution](#)

(B) Meical entrance special format questions (Match the columns)

1. Match the following columns.

Column I	Column II
(A) $d v/dt$	(p) Acceleration
(B) $d v /dt$	(q) Magnitude of acceleration
(C) $\frac{dr}{dt}$	(r) Velocity
(D) $\left \frac{dr}{dt} \right $	(s) Magnitude of velocity
	(t) Rate of change of speed

 [Watch Video Solution](#)

2. In the s-t equation ($s = 10 + 20t - 5t^2$) match the following columns.

Column I	Column II
(A) Distance travelled in 3s	(p) -20 units
(B) Displacement 1 s	(q) 15 units
(C) Initial acceleration	(r) 25 units
(D) Velocity at 4 s	(s) -10 units

 Watch Video Solution

3. Velocity of a particle is in negative direction with constant acceleration in positive direction. Then match the following:

Table-1	Table-2
(A) Velocity-time graph	(P) Slope \rightarrow negative
(B) Acceleration-time graph	(Q) Slope \rightarrow positive
(C) Displacement-time graph	(R) Slope \rightarrow zero
	(S) Slope \rightarrow increasing
	(T) Slope \rightarrow decreasing
	(U) Slope \rightarrow constant

 Watch Video Solution

4. Match the following columns.

Column I

- (A) Constant positive acceleration
- (B) Constant negative acceleration
- (C) Constant displacement
- (D) Constant slope of a-t graph

Column II

- (p) Speed may increase
- (q) Speed may decrease
- (r) Speed is zero
- (s) Speed must increase
- (t) Speed must decrease



Watch Video Solution

5. For the velocity time graph shown in figure, in a time interval from $t = 0$ to $t = 6$ s match the following

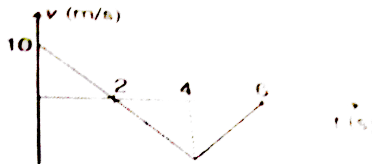

Table-1

- (A) Change in velocity
- (B) Average acceleration
- (C) Total displacement
- (D) Acceleration at $t = 3$ s

Table-2

- (P) $-\frac{5}{3}$ SI unit
- (Q) -20 SI unit
- (R) -10 SI unit
- (S) -5 SI unit



Watch Video Solution

6. Let us call a motion, A when velocity is positive and increasing A^{-1} when velocity is negative and increasing R when velocity is positive and decreasing and R^{-1} when velocity is negative and decreasing. Now match the following two tables for the given $s - t$ graph

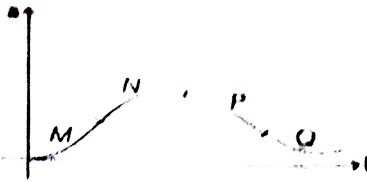

Table-1

Table-2

- (A) M
- (B) N
- (C) P
- (D) Q

- (P) A^{-1}
- (Q) R^{-1}
- (R) A
- (S) R

[Watch Video Solution](#)

1. If the velocity of a particle is $v = At + Bt^2$, where A and B are constant, then the distance travelled by it between $1s$ and $2s$ is :

A. $3A + 7B$

B. $\frac{3}{2}A + \frac{7}{3}B$

C. $\frac{A}{2} + \frac{B}{3}$

D. $\frac{3}{2}A + 4B$

Answer: B



Watch Video Solution

2. A particle of unit mass undergoes one-dimensional motion such that its velocity varies according to

$$v(x) = \beta x^{-2n}$$

where β and n are constant and x is the position of the particle.

The acceleration of the particle as a function of x is given by.

A. $-2n\beta^2 x^{-2n-1}$

B. $-2n\beta^2 x^{-4n-1}$

C. $-2\beta^2 x^{-2n+1}$

D. $-2n\beta^2 x^{-4n+1}$

Answer: B



[Watch Video Solution](#)

3. The ball is dropped from a bridge $122.5m$ above a river, After the ball has been falling for 2 s , a second ball is thrown straight down after it. What must its initial velocity be so that both hit the water at the same time ?

A. $40ms^{-1}$

B. $55.5ms^{-1}$

C. $26.1ms^{-1}$

D. $9.6ms^{-1}$

Answer: C

 [Watch Video Solution](#)

4. A ball is thrown vertically upwards from the ground with a speed of $25.2ms^{-1}$. How long does it take to reach its highest point and how high does it rise ? (Take $g = 9.8ms^{-2}$)

A. $2.75s, 3.24m$

B. $25.7s, 34.2m$

C. $2.57s, 32.4m$

D. $27.5s, 3.42m$

Answer: C



Watch Video Solution

5. A particle moves in an XY-plane in such a way that its x and y-coordinates vary with time according to

$$x(t) = t^3 - 32t, y(t) = 5t^2 + 12$$

Find the acceleration of the particle, if $t = 3$ s.

A. $9\hat{i} + 5\hat{j}$

B. $18\hat{i} + 10\hat{j}$

C. $18\hat{i} - 5\hat{j}$

D. $-18\hat{i} + 10\hat{j}$

Answer: B



Watch Video Solution

6. A point moving with constant acceleration from A to B in the straight line AB has velocities u and v at A and B respectively. Find its velocity at C, the mid point of AB. Also show that if the time from A to C is twice that from C to B, then $v = 7u$.

A. $5u$

B. $6u$

C. $7u$

D. $8u$

Answer: C



Watch Video Solution

7. The displacement-time graph of a particle is as shown below. It indicates that

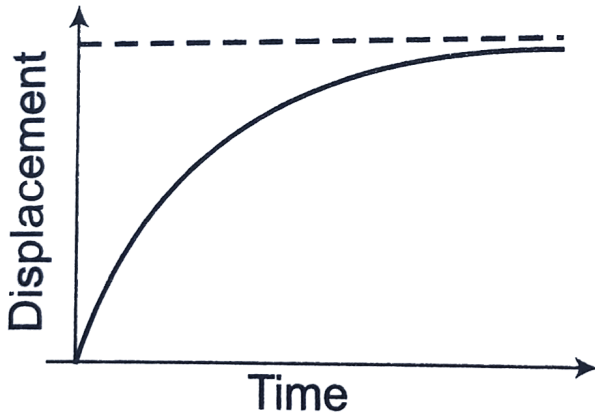

- A. the velocity of the particle is constant throughout
- B. the acceleration of the particle is constant throughout
- C. the particle starts with a constant velocity and is accelerated
- D. the motion is retarded and finally the particle stops

Answer: D

8. A car starts from rest and accelerates uniformly to a speed of 180kmh^{-1} in 10 s. The distance covered by the car in the time interval is

- A. 200 m
- B. 300 m
- C. 500 m
- D. 250 m

Answer: D



[Watch Video Solution](#)

9. The velocity - time graph for two bodies A and B are shown in figure. Then, the acceleration of A and B are in the ratio

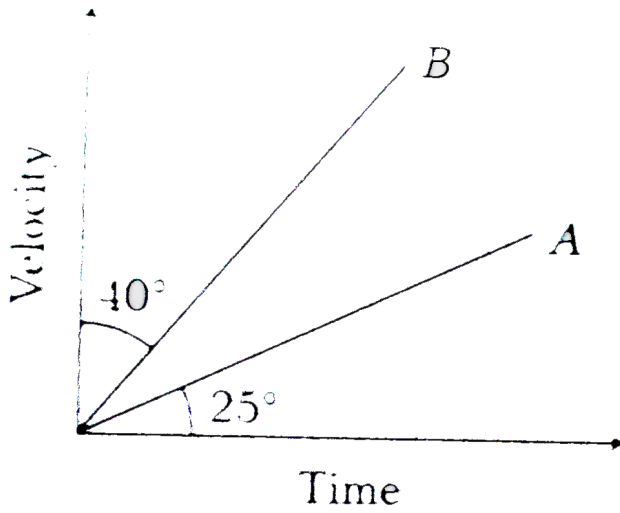

- A. $\sin 25^\circ$ to $\sin 50^\circ$
- B. $\tan 25^\circ$ to $\tan 40^\circ$
- C. $\cos 25^\circ$ to $\cos 50^\circ$
- D. $\tan 25^\circ$ to $\tan 50^\circ$

Answer: D

 [Watch Video Solution](#)

10. A particle is moving such that its position coordinates (x, y) are $(2m, 3m)$ at time $t = 0$, $(6m, 7m)$ at time $t = 2s$, and $(13m, 14m)$ at time $t = 5s$.

Average velocity vector $\left(\vec{V}_{av}\right)$ from $t = 0$ to $t = 5s$ is

A. $\frac{1}{5} \left(13\hat{i} + 14\hat{j} \right)$

B. $\frac{7}{3} \left(\hat{i} + \hat{j} \right)$

C. $\left(\hat{i} + \hat{j} \right)$

D. $\frac{11}{5} \left(\hat{i} + \hat{j} \right)$

Answer: D



Watch Video Solution

11. A ball thrown vertically upwards after reaching a maximum height h returns to the starting point after a time of 10 s. Its

displacement after 5 s is

- A. h
- B. 2h
- C. 10h
- D. 20h

Answer: A

 [Watch Video Solution](#)

12. A police jeep is chasing with, velocity of $45\text{km}/\text{h}$ a thief in another jeep moving with velocity $153\text{km}/\text{h}$. Police fires a bullet with muzzle velocity of $180\text{m}/\text{s}$. The velocity it will strike the car of the thief is.

- A. $150\text{m}\cdot\text{s}^{-1}$

B. $27ms^{-1}$

C. $450ms^{-1}$

D. $250ms^{-1}$

Answer: A



Watch Video Solution

13. A particle moves with constant acceleration along a straight line streaming from rest. The percentage increase in its displacement during the 4th second compared to that in the 3rd second is

A. 33 %

B. 40 %

C. 66 %

D. 77 %

Answer: B



Watch Video Solution

14. A car covers the first half of the distance between two places at a speed of 40kmh^{-1} and second half at 60kmh^{-1} . Calculate the average speed of the car.

A. 40kmh^{-1}

B. 48kmh^{-1}

C. 50kmh^{-1}

D. 60kmh^{-1}

Answer: B



Watch Video Solution

15. A particle starts moving from rest under uniform acceleration it travels a distance x in the first two seconds and a distance y in the next two seconds. If $y = nx$, then $n =$

A. $y = 3x$

B. $y = 4x$

C. $y = x$

D. $y = 2x$

Answer: A



[Watch Video Solution](#)

16. At time $t = 0$, two bodies A and B at the same point. A moves with constant velocity v and B starts from rest and moves with

constant acceleration. Relative velocity of B w.r.t. A when the bodies meet each other is

A. $\frac{v}{2}$

B. $\frac{v}{3}$

C. v

D. $2v$

Answer: C



[Watch Video Solution](#)

17. A motorclist drives from A to B with a uniform speed of 30kmh^{-1} and returns back with a speed of 20kmh^{-1} . Find its average speed.

A. 25kmh^{-1}

B. 24kmh^{-1}

C. 50kmh^{-1}

D. 10kmh^{-1}

Answer: B



Watch Video Solution

18. A body starts from rest and moves with constant acceleration for t s. It travels a distance x_1 in first half of time and x_2 in next half of time, then

A. $x_2 = x_1$

B. $x_2 = 2x_1$

C. $x_2 = 3x_1$

D. $x_2 = 4x_1$

Answer: D



Watch Video Solution

19. The acceleration of a moving body can be found from

- A. area under velocity - time graph
- B. area under displacement - time graph
- C. slope of distance - time graph
- D. slope of velocity - time graph

Answer: D



Watch Video Solution

20. A stone falls freely under gravity. It covered distances h_1 , h_2 and h_3 in the first 5 seconds. The next 5 seconds and the next 5 seconds respectively. The relation between h_1 , h_2 and h_3 is :

A. $h_1 = 2h_2 = 3h_3$

B. $h_1 = \frac{h_2}{3} = \frac{h_3}{5}$

C. $h_2 = 3h_1$ and $h_3 = 3h_2$

D. $h_1 = h_2 = h_3$

Answer: B



Watch Video Solution

21. The motion of a particle in straight line is an example of

A. constant velocity motion

- B. uniformly acceleration motion
- C. non-uniformly acceleration motion
- D. zero velocity motion

Answer: B



[Watch Video Solution](#)

22. The velocity-time graph of particle comes out to be a non-linear curve. The motion is

- A. uniform velocity motion
- B. uniformly accelerated motion
- C. non-uniform accelerated motion
- D. Nothing can be said about the motion

Answer: C

 [Watch Video Solution](#)

23. A person reaches on a point directly opposite on the other bank of a river. The velocity of the water in the river is 4 m/s and the velocity of the person in still water is 5 m/s . If the width of the river is 84.6 m , time taken to cross the river in seconds is

A. 28.2

B. 9.4

C. 2

D. 84.6

Answer: A

 [Watch Video Solution](#)

24. A body is thrown vertically upward from a point A 125 m above the ground. It goes up to a maximum height of 250 m above the ground and passes through A on its downward journey. The velocity of the body when it is at a height of 70 m above the ground is ($g = 10\text{ m/s}^2$)

A. 50 m/s^{-1}

B. 60 m/s^{-1}

C. 80 m/s^{-1}

D. 20 m/s^{-1}

Answer: B



Watch Video Solution

25. A particle is moving eastwards with velocity of $5m/s$. In 10 sec the velocity changes to $5m/s$ northwards. The average acceleration in this time is.

- A. $\frac{1}{\sqrt{2}}m/s^2$ (North-West)
- B. $\frac{1}{\sqrt{2}}m/s^2$ (North-East)
- C. $\sqrt{2}m/s^2$ (North-West)
- D. $\sqrt{2}m/s^2$ (North-East)

Answer: C



[Watch Video Solution](#)

26. The velocity-time graph of robber's car and a chasing police car are shown in the following graph. Police car crosses the

robber's car in time

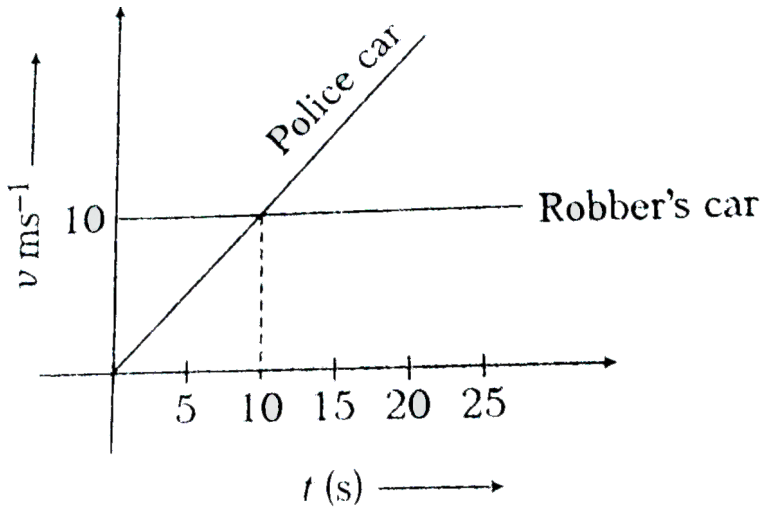

- A. 10 s after it starts
- B. 1 s after it starts
- C. 20 s after it starts
- D. Never crosses

Answer: C

 [Watch Video Solution](#)

27. Initial speed of an α particle inside a tube of length 4m is 1km s^{-1} , if it is accelerated in the tube and comes out with a speed of 9km s^{-1} , then the time for which the particle remains inside the tube is

A. $8 \times 10^{-3}\text{s}$

B. $8 \times 10(-4)\text{s}$

C. $80 \times 10^{-3}\text{s}$

D. $800 \times 10^{-3}\text{s}$

Answer: B



Watch Video Solution

28. A body X is projected upwards with a velocity of 98m s^{-1} , after 4s, a second body Y is also projected upwards with the same

initial velocity . Two bodies will meet after

- A. 8 s
- B. 10 s
- C. 12 s
- D. 14 s

Answer: C

 [Watch Video Solution](#)

29. Let $r_1(t) = 3t\hat{i} + 4t^2\hat{j}$

and $r_2(t) = 4t^2\hat{i} + 3t\hat{j}$

represent the positions of particles 1 and 2, respectively, as function of time t , $r_1(t)$ and $r_2(t)$ are in meter and t in second.

The relative speed of the two particle at the instant $t = 1$ s, will be

A. 1 m/s

B. $3\sqrt{2} \text{ m/s}$

C. $5\sqrt{2} \text{ m/s}$

D. $7\sqrt{2} \text{ m/s}$

Answer: C

 [Watch Video Solution](#)

30. The motion of a particle along a straight line is described by equation : $x = 8 + 12t - t^3$ where x is in meter and t in second.

The retardation of the particle when its velocity becomes zero is.

A. 24 m s^{-2}

B. zero

C. 6 m s^{-2}

D. $12ms^{-2}$

Answer: D



Watch Video Solution

31. A scooter starts from rest have an acceleration of $1ms^{-2}$ while a car 150 m behind it starts from rest with an acceleration of $2ms^{-2}$. After how much time the car catches up with the scooter ?

A. $\sqrt{700}s$

B. $\sqrt{300}s$

C. $\sqrt{150}s$

D. None of the above

Answer: B



Watch Video Solution

32. The displacement x of a particle along a straight line at time t is given by $x = a_0 + a_1t + a_2t^2$. The acceleration of the particle is

A. a_0

B. a_1

C. a_2

D. $2a_2$

Answer: D



Watch Video Solution