



PHYSICS

BOOKS - DC PANDEY ENGLISH

PROJECTILE MOTION

Example

1. A particle is projected with a velocity of 50 m/s at 37° with horizontal. Find velocity, displacement and co-ordinates of the particle

(w.r.t. the starting point) after 2 s.

Given,

$$g = 10 \text{ m/s}^2, \sin 37^\circ = 0.6 \text{ and } \cos 37^\circ = 0.8$$

.



[Watch Video Solution](#)

2. A particle is projected with velocity u at angle θ with horizontal. Find the time when velocity vector is perpendicular to initial velocity vector.



[Watch Video Solution](#)

3. A projectile is fired horizontally with velocity of 98 m/s from the top of a hill 490 m high.

Find

(a) the time taken by the projectile to reach the ground,

(b) the distance of the point where the particle hits the ground from foot of the hill and

(c) the velocity with which the projectile hits

the ground. ($g = 9.8m / s^2$)

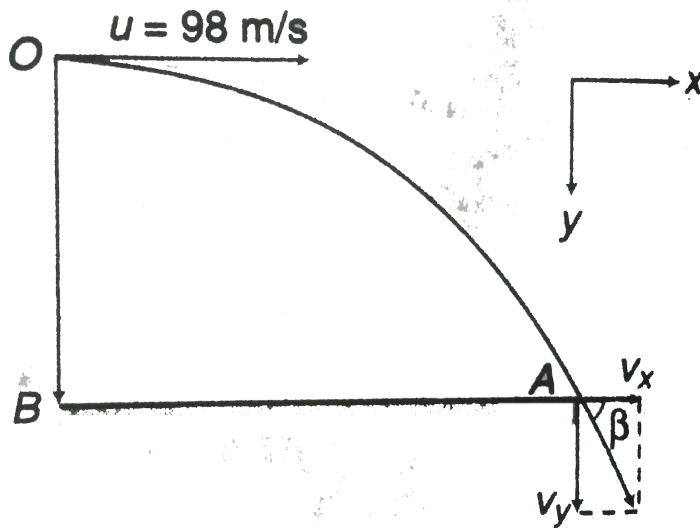

[Watch Video Solution](#)

4. A body is thrown horizontally from the top of a tower and strikes the ground after three seconds at an angle of 45° with the

horizontal. Find the height of the tower and the speed with which the body was projected.

$$(Take\ g = 9.8\ m / s^2)$$



Watch Video Solution

5. Find the angle of projection of a projectile for which the horizontal range and maximum height are equal.



Watch Video Solution

6. Prove that the maximum horizontal range is four times the maximum height attained by the projectile, when fired at an inclination so as to have maximum horizontal range.



[Watch Video Solution](#)

7. For given value of u , there are two angles of projection for which the horizontal range is the same. Show that the sum of the maximum

heights for these two angles is independent of the angle of projection.



[Watch Video Solution](#)

8. Show that there are two values of time for which a projectile is at the same height. Also show mathematically that the sum of these two times is equal to the time of flight.



[Watch Video Solution](#)

9. A man standing on a hill top projects a stone horizontally with speed v_0 as shown in figure. Taking the co-ordinate system as given in the figure. Find the co-ordinates of the point where the stone will hit the hill surface.

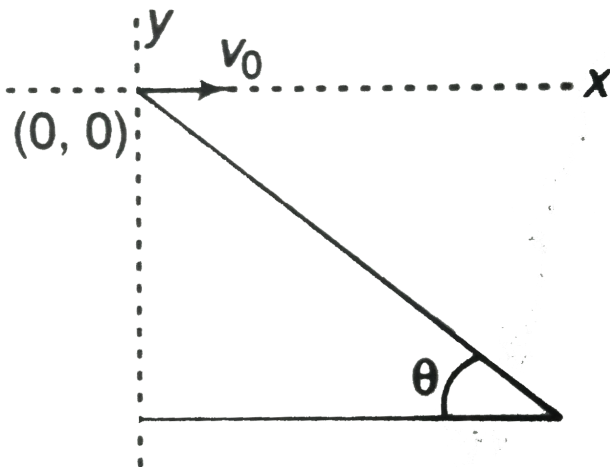

[Watch Video Solution](#)

10. A particle A is projected with an initial velocity of 60m/s at an angle 30° to the horizontal. At the same time a second particle B is projected in opposite direction with initial speed of 50m/s from a point at a distance of 100m from A. If the particles collide in air, find (a) the angle of projection α of particle B, (b) time when the collision takes place and (c) the distance of P from A, where collision occurs.

$$(g = 10 \text{ m/s}^2)$$

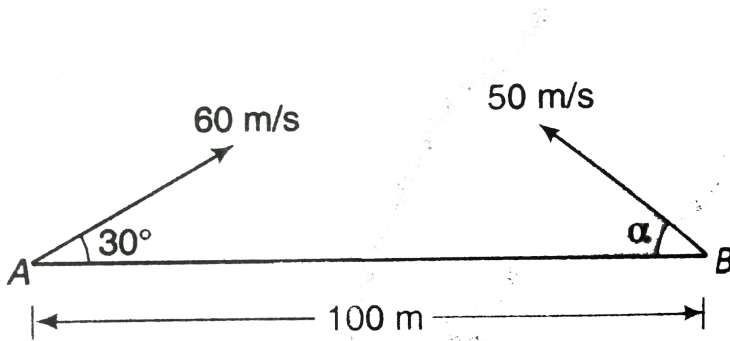

[Watch Video Solution](#)

Example Type 1

1. A particle is projected from ground with velocity 40 m/s at 60° from horizontal.

(a) Find the speed when velocity of the particle makes an angle of 37° from horizontal.

(b) Find the time for the above situation.

(c) Find the vertical height and horizontal distance of the particle from the starting point in the above position. Take $g = 10\text{m} / \text{s}^2$.



[Watch Video Solution](#)

Example Type 2

1. In the figures shown, three particles are thrown from a tower of height 40 m as shown in figure. In each case find the time when the particles strike the ground and the distance of this point from foot of the tower.



[View Text Solution](#)

Example Type 3

1. A ball rolls off the edge of a horizontal table top 4 m high. If it strikes the floor at a point 5 m horizontally away from the edge of the table, what was its speed at the instant it left the table?



[Watch Video Solution](#)

2. An aeroplane is flying in a horizontal direction with a velocity 600 km/h at a height of 1960 m. When it is vertically above the point

A on the ground, a body is dropped from it.
The body strikes the ground at point B.
Calculate the distance AB.

 [Watch Video Solution](#)

3. In the figure shown, find

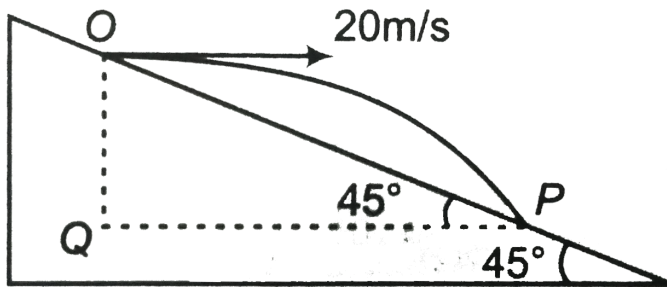

(a) the time of flight of the projectile over the

inciled plane.

(b) range OP.



Watch Video Solution

4. In the figure shown, find

(a) the time when the particle strikes the ground at P.

(b) the horizontal distance QP

(c) velocity of the particle at P.

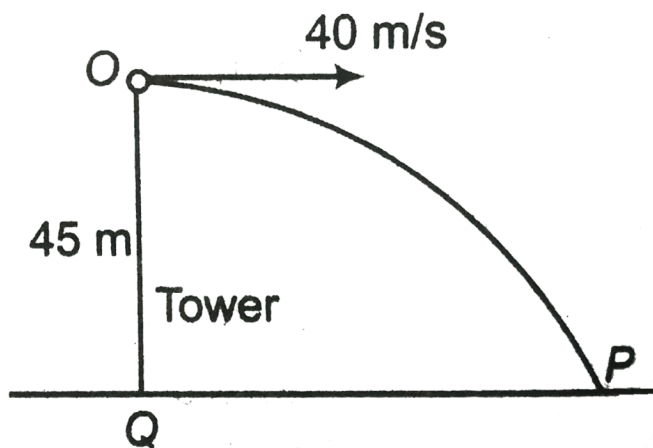

[Watch Video Solution](#)

Example Type 4

1. A particle moves in the plane xy with constant acceleration 'a' directed along the negative y -axis. The equation of motion of the particle has the form $y = px - qx^2$ where p and q are positive constants. Find the velocity of the particle at the origin of co-ordinates.



[Watch Video Solution](#)

Example Type 5

1. In the figure shown, find.

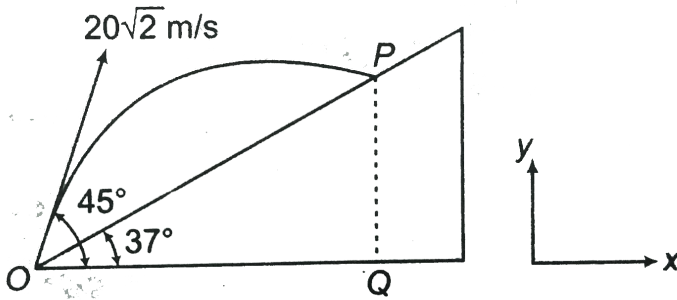

(a) time of flight of the projectile along the inclined plane.

(b) range OP .



[Watch Video Solution](#)

2. In the figure shown, find.

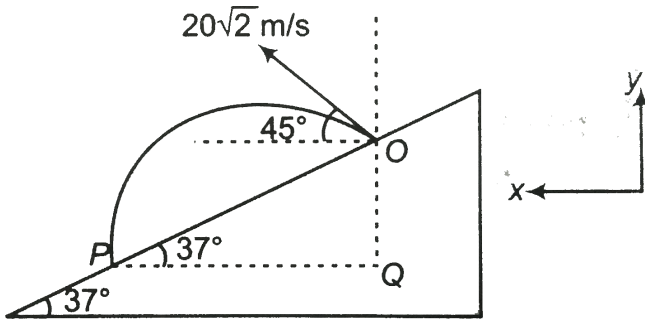

(a) time of flight of the projectile along the inclined plane.

(b) range OP .



[Watch Video Solution](#)

3. At a height of 45 m from ground velocity of a projectile is,

$$v = (30\hat{i} + 40\hat{j}) \text{ m/s}$$

Find initial velocity, time of flight, maximum height and horizontal range of this projectile.

Here \hat{i} and \hat{j} are the unit vectors in horizontal and vertical directions.



[Watch Video Solution](#)

Miscellaneous Examples

1. A particle is thrown over a triangle from one end of a horizontal base and after grazing the vertex falls on the other end of the base. If α and β be the base angles and θ the angle of projection, prove that $\tan \theta = \tan \alpha + \tan \beta$.



[Watch Video Solution](#)

2. The velocity of a projectile when it is at the greatest height is $\left(\sqrt{2/5}\right)$ times its velocity

when it is at half of its greatest height.

Determine its angle of projection.



[Watch Video Solution](#)

3. A car accelerating at the rate of 2 m/s^2 from rest from origin is carrying a man at the rear end who has a gun in his hand. The car is always moving along positive x-axis. At $t = 4 \text{ s}$, the man fires a bullet from the gun and the bullet hits a bird at $t = 8 \text{ s}$. The bird has a position vector $40\hat{i} + 80\hat{j} + 40\hat{k}$. Find velocity

of projection of the bullet. Take the y-axis in the horizontal plane. ($g = 10m / s^2$).

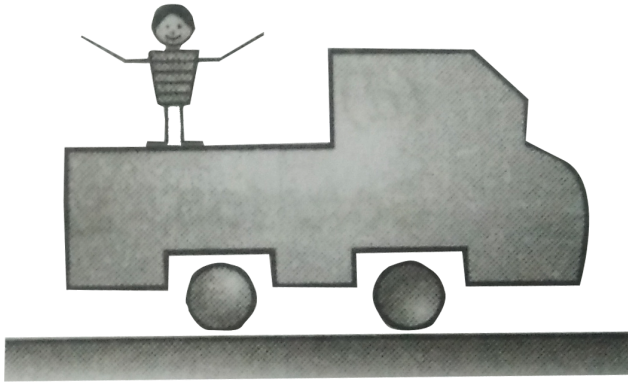

[Watch Video Solution](#)

4. Two inclined planes OA and OB having inclinations 30° and 60° with the horizontal

respectively intersect each other at O , as shown in figure. A particle is projected from point P with velocity $u = 10\sqrt{3} \text{ m/s}$ along a direction perpendicular to plane OA . If the particle strikes plane OB perpendicular at Q . Calculate.

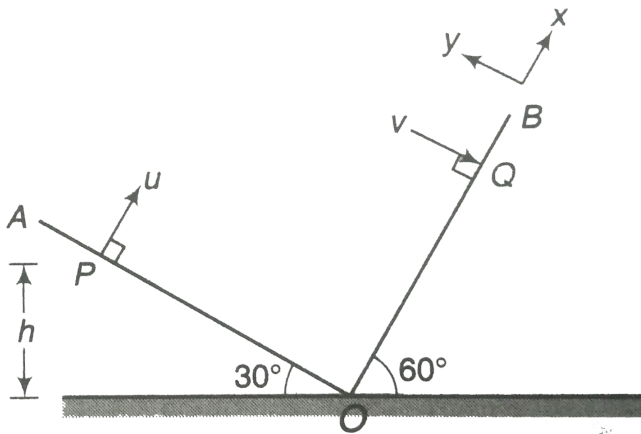

(a) time of flight,

(b) velocity with which the particle strikes the

plane OB,

(c) height h of point P from point O,

(d) distance PQ. (Take $g = 10\text{m} / \text{s}^2$)



[Watch Video Solution](#)

Exercise 7 1

1. Two particles are projected from a tower horizontally in opposite directions with velocities $10\text{m} / \text{s}$ and $20\text{m} / \text{s}$. Find the time

when their velocity vectors are mutually perpendicular. Take $g = 10\text{m} / \text{s}^2$.



[Watch Video Solution](#)

2. Projectile motion is a 3-dimensional motion.

Is this statement true or false ?



[Watch Video Solution](#)

3. Projectile motion (at low speed) is uniformly accelerated motion. Is this statement true or

false?



[Watch Video Solution](#)

4. A particle is projected from ground with velocity $50m/s$ at 37° from horizontal. Find velocity and displacement after 2 s.

$$\sin 37^\circ = \frac{3}{5}.$$



[Watch Video Solution](#)

5. A particle is projected from a tower of height 25 m with velocity $20\sqrt{2}m/s$ at 45° .

(a) Find the time when particle strikes with ground. (b) The horizontal distance from the foot of tower where it strikes. (c) Also find the velocity at the time of collision.



Watch Video Solution

Exercise 7 2

1. A particle is projected from ground with velocity $40(\sqrt{2})\text{ m/s}$ at 45° . Find

(a) velocity and

(b) displacement of the particle after 2 s.

$$(g = 10\text{ m/s}^2)$$



Watch Video Solution

2. Under what conditions the formulae of range, time of flight and maximum height can

be applied directly in case of a projectile motion ?



[Watch Video Solution](#)

3. What is the average velocity of a particle projected from the ground with speed u at an angle α with horizontal over a time interval from beginning till it strikes the ground again?



[Watch Video Solution](#)

4. What is the change in velocity in the above question?



Watch Video Solution

5. A particle is projected from ground with initial velocity $u = 20(\sqrt{2})\text{ m/s}$ at $\theta = 45^\circ$.

Find

(a) R,H and T,

(b) velocity of particle after 1 s

(c) velocity of particle at the time of collision

with the ground (x-axis).

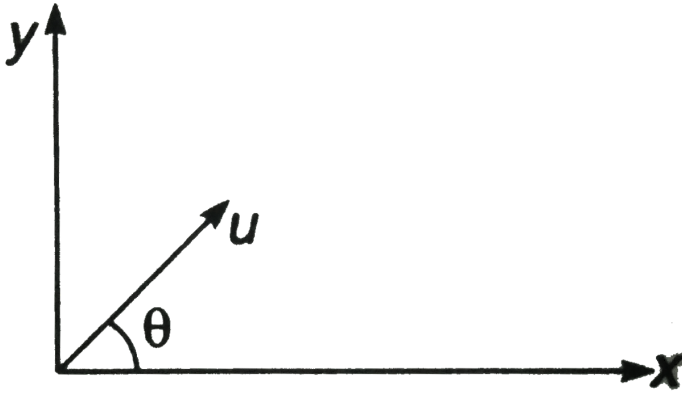

[Watch Video Solution](#)

6. A particle is projected from ground at angle 45° with initial velocity $20(\sqrt{2})\text{ m / s}$. Find
- (a) change in velocity,

(b) magnitude of average velocity in a time interval from $t = 0$ to $t = 3s$.



Watch Video Solution

7. The coach throws a baseball to a player with an initial speed of $20m/s$ at an angle of 45° with the horizontal. At the moment the ball is thrown, the player is 50 m from the coach. At what speed and in what direction must the player run to catch the ball at the same height at which it was released? ($g = 10m/s^2$).



[Watch Video Solution](#)

8. A ball is thrown horizontally from a point 100m above the ground with a speed of 20m/s . Find (a) the time it takes to reach the ground, (b) the horizontal distance it travels before reaching the ground, (c) the velocity (direction and magnitude) with which it strikes the ground.



[Watch Video Solution](#)

9. A bullet fired at an angle of 30° with the horizontal hits the ground 3.0 km away. By adjusting its angle of projection, can one hope to hit a target 5.0 away? Assume the muzzle speed to be fixed and neglect air resistance.



Watch Video Solution

10. A particle moves in the plane xy with constant acceleration 'a' directed along the negative y -axis. The equation of motion of the

particle has the form $y = px - qx^2$ where p and q are positive constants. Find the velocity of the particle at the origin of co-ordinates.



[Watch Video Solution](#)

Exercise 7 3

1. Find time of flight and range of the projectile along the inclined plane as shown in

figure. ($g = 10\text{ m/s}^2$)

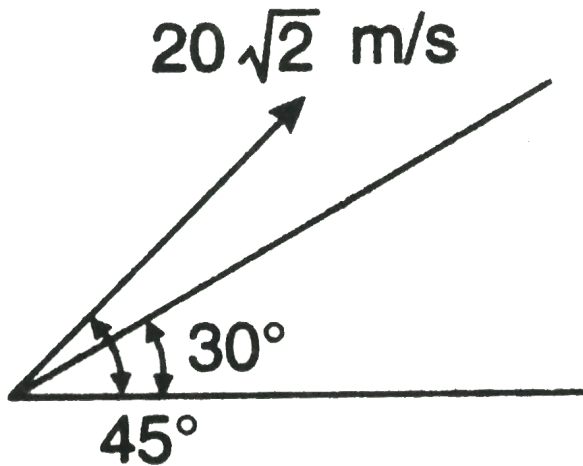

[Watch Video Solution](#)

2. Find time of flight and range of the projectile along the inclined plane as shown in

figure. ($g = 10\text{m} / \text{s}^2$)

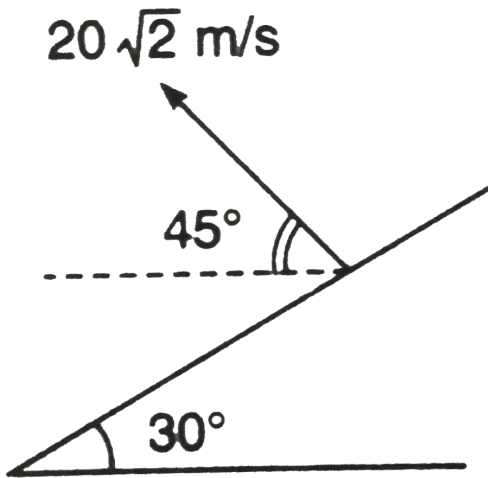

[Watch Video Solution](#)

3. Find time of flight and range of the projectile along the inclined plane as shown in

figure. ($g = 10\text{ m/s}^2$)

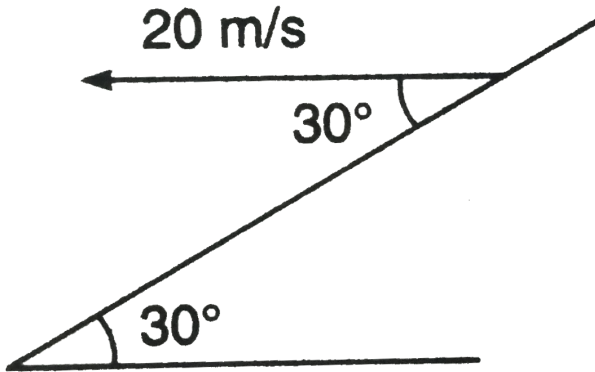

[Watch Video Solution](#)

4. Passenger of a train just drops a stone from it. The train was moving with constant velocity. What is path of the stone as observed by (a)

the passenger itself, (b) a man standing on ground?



Watch Video Solution

5. A particle is projected upwards with velocity 20 m/s . Simultaneously another particle is projected with velocity $20(\sqrt{2})\text{ m/s}$ at 45° .

$$(g = 10\text{ m/s}^2)$$

(a) What is acceleration of first particle relative to the second?

(b) What is initial velocity of first particle

relative to the other?

(c) What is distance between two particles after 2 s?



[Watch Video Solution](#)

6. A particle is projected from the bottom of an inclined plane of inclination 30° . At what angle α (from the horizontal) should the particle be projected to get the maximum range on the inclined plane.



[Watch Video Solution](#)

Level 1 Assertion And Reason

1. Assertion: A particle follows only a parabolic path if acceleration is constant.

Reason : In projectile motion path is parabolic, as acceleration is assumed to be constant at low heights.

A. (a) If both Assertion and Reason are true and the Reason is correct explanation of the Assertion.

B. (b) If both Assertion and Reason are true and the Reason is not the correct explanation of the Assertion.

C. (c) If Assertion is true, but the Reason is false.

D. (d) If Assertion is false, but the Reason is true.

Answer: D



Watch Video Solution

2. Assertion : Projectile motion is called a two dimensional motion, although it takes place in space.

Reason : In space it takes place in a plane.

A. (a) If both Assertion and Reason are true and the Reason is correct explanation of the Assertion.

B. (b) If both Assertion and Reason are true and the Reason is not the correct explanation of the Assertion.

C. (c) If Assertion is true, but the Reason is false.

D. (d) If Assertion is false, but the Reason is true.

Answer: A



Watch Video Solution

3. Assertion : If time of flight in a projectile motion is made two times, its maximum height will become four times.

Reason : In projectile motion $H \propto T^2$, where
H is maximum height and T the time of flight.

A. (a) If both Assertion and Reason are true
and the Reason is correct explanation of
the Assertion.

B. (b) If both Assertion and Reason are true
and the Reason is not the correct
explanation of the Assertion.

C. (c) If Assertion is true, but the Reason is
false.

D. (d) If Assertion is false, but the Reason is true.

Answer: A



Watch Video Solution

4. Assertion : A particle is projected with velocity u at angle 45° with ground. Let v be the velocity of particle at time ($\neq 0$), then value of $u \cdot v$ can be zero.

Reason : Value of dot product is zero when angle between two vectors is 90°

A. (a) If both Assertion and Reason are true and the Reason is correct explanation of the Assertion.

B. (b) If both Assertion and Reason are true and the Reason is not the correct explanation of the Assertion.

C. (c) If Assertion is true, but the Reason is false.

D. (d) If Assertion is false, but the Reason is true.

Answer: B



Watch Video Solution

5. Assertion : A particle has constant acceleration in x-y plane. But neither of its acceleration components (a_x and a_y) is zero. Under this condition particle cannot have parabolic path.

Reason : In projectile motion, horizontal component of acceleration is zero.

A. (a) If both Assertion and Reason are true and the Reason is correct explanation of the Assertion.

B. (b) If both Assertion and Reason are true and the Reason is not the correct explanation of the Assertion.

C. (c) If Assertion is true, but the Reason is false.

D. (d) If Assertion is false, but the Reason is true.

Answer: D



Watch Video Solution

6. Assertion : In projectile motion at any two positions $\frac{v_2 - v_1}{t_2 - t_1}$ always remains constant.

Reason : The given quantity is average acceleration, which should remain constant as acceleration is constant.

A. (a) If both Assertion and Reason are true and the Reason is correct explanation of the Assertion.

B. (b) If both Assertion and Reason are true and the Reason is not the correct explanation of the Assertion.

C. (c) If Assertion is true, but the Reason is false.

D. (d) If Assertion is false, but the Reason is true.

Answer: A



Watch Video Solution

7. Assertion : Particle A is projected upwards. Simultaneously particle B is projected as projectile as shown. Particle A returns to ground in 4s. At the same time particle B collides with A. Maximum height H attained by B would be 20 m. ($g = 10ms^{-2}$).

Reason : Speed of projectile of both the particles should be same under the given

condition.

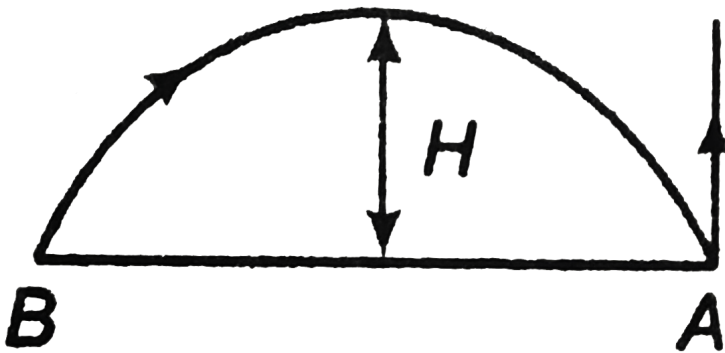

A. (a) Both Assertion and Reason are true and the Reason is correct explanation of the Assertion.

B. (b) Both Assertion and Reason are true and the Reason is not the correct explanation of the Assertion.

C. (c) Assertion is true, but the Reason is false.

D. (d) Assertion is false, but the Reason is true.

Answer: C



Watch Video Solution

8. Assertion : Two projectile have maximum heights $4H$ and H respectively. The ratio of their horizontal components of velocities

should be 1:2 for their horizontal ranges to be same.

Reason : Horizontal range = horizontal component of velocity \times time of flight.

A. (a) If both Assertion and Reason are true and the Reason is correct explanation of the Assertion.

B. (b) If both Assertion and Reason are true and the Reason is not the correct explanation of the Assertion.

C. (c) If Assertion is true, but the Reason is false.

D. (d) If Assertion is false, but the Reason is true.

Answer: A::B



Watch Video Solution

9. Assertion : If $g = 10m/s^2$ then in projectile motion speed of particle in every second will change by $10ms^{-1}$.

Reason : Acceleration is nothing but rate of change of velocity.

A. (a) If both Assertion and Reason are true and the Reason is correct explanation of the Assertion.

B. (b) If both Assertion and Reason are true and the Reason is not the correct explanation of the Assertion.

C. (c) If Assertion is true, but the Reason is false.

D. (d) If Assertion is false, but the Reason is true.

Answer: D



Watch Video Solution

10. Assertion : In projectile motion if particle is projected with speed u , then speed of particle at height h would be $\left(\sqrt{u^2 - 2gh}\right)$.

Reason : If particle is projected with vertical component of velocity u_y . Then vertical

component at the height h would be $\pm \left(\sqrt{u_y^2 - 2gh} \right)$.

A. (a) If both Assertion and Reason are true and the Reason is correct explanation of the Assertion.

B. (b) If both Assertion and Reason are true and the Reason is not the correct explanation of the Assertion.

C. (c) If Assertion is true, but the Reason is false.

D. (d) If Assertion is false, but the Reason is true.

Answer: B



Watch Video Solution

Level 1 Single Correct

1. Identify the correct statement related to the projectile motion.

A. (a) It is uniformly accelerated everywhere

B. (b) It is uniformly accelerated

everywhere except at the highest

position where it is moving with

constant velocity

C. (c) Acceleration is never perpendicular to

velocity

D. (d) None of the above

Answer: A



Watch Video Solution

2. Two bodies are thrown with the same initial velocity at angles θ and $(90^\circ - \theta)$ respectively with the horizontal, then their maximum height are in the ratio

A. $1 : 1$

B. $\sin \theta : \cos \theta$

C. $\sin^2 \theta : \cos^2 \theta$

D. $\cos \theta : \sin \theta$

Answer: C



Watch Video Solution

3. The range of a projectile at an angle θ is equal to half of the maximum range if thrown at the same speed. The angle of projection θ is given by

A. 15°

B. 30°

C. 60°

D. data insufficient

Answer: A



Watch Video Solution

4. A ball is projecte with a velocity $20ms^{-1}$ at an angle to the horizontal. In order to have the maximum range. Its velocity at the highest position must be

A. $10ms^{-1}$

B. $14ms^{-1}$

C. $18ms^{-1}$

D. $16ms^{-1}$

Answer: B



Watch Video Solution

5. A particular has initial velocity, $v = 3\hat{i} + 4\hat{j}$
and a constant force $F = 4\hat{i} - 3\hat{j}$ acts on it.

The path of the particle is

A. straight line

B. parabolic

C. circular

D. elliptical

Answer: B



Watch Video Solution

6. A body is projected at an angle 60° with horizontal with kinetic energy K . When the velocity makes an angle 30° with the horizontal, the kinetic energy of the body will be

A. $K/2$

B. $K/3$

C. $2K/3$

D. $3K/4$

Answer: B



Watch Video Solution

7. If T_1 and T_2 are the times of flight for two complementary angles, then the range of projectile R is given by

A. $R = 4gT_1T_2$

B. $R = 2gT_1T_2$

C. $R = \frac{1}{4}gT_1T_2$

D. $R = \frac{1}{2}gT_1T_2$

Answer: D



Watch Video Solution

8. A gun is firing bullets with velocity v_0 by rotating it through 360° in the horizontal

plane. The maximum area covered by the bullets is

A. $\frac{\pi v_0^2}{g}$

B. $\frac{\pi^2 v_0^2}{g}$

C. $\frac{\pi v_0^4}{g^2}$

D. $\frac{\pi^2 v_0^4}{g}$

Answer: C



Watch Video Solution

9. A grass hopper can jump maximum distance 1.6m . It spends negligible time on ground. How far can it go in $10(\sqrt{2})\text{s}$?

A. 45 m

B. 30 m

C. 20 m

D. 40 m

Answer: D



Watch Video Solution

10. Two stones are projected with the same speed but making different angles with the horizontal. Their horizontal ranges are equal. The angle of projection of one is $\frac{\pi}{3}$ and the maximum height reached by it is 102 m. Then the maximum height reached by the other in metres is

A. 76

B. 84

C. 56

D. 34

Answer: D



Watch Video Solution

11. A ball is projected upwards from the top of a tower with a velocity $50ms^{-1}$ making an angle 30° with the horizontal. The height of tower is 70m. After how many seconds from the instant of throwing, will the ball reach the ground. ($g = 10ms^{-2}$)

A. 2 s

B. 5 s

C. 7 s

D. 9 s

Answer: C



Watch Video Solution

12. Average velocity of a particle in projectile motion between its starting point and the

highest point of its trajectory is (projectin
speed = u , angle projection from horizontal = θ)

A. $u \cos \theta$

B. $\frac{u}{2} \left(\sqrt{1 + 3 \cos^2 \theta} \right)$

C. $\frac{u}{2} \left(\sqrt{2 + \cos^2 \theta} \right)$

D. $\frac{u}{2} \left(\sqrt{1 + \cos^2 \theta} \right)$

Answer: B



Watch Video Solution

13. A train is moving on a track at 30ms^{-1} . A ball is thrown from it perpendicular to the direction of motion with 30ms^{-1} at 45° from horizontal. Find the distance of ball from the point of projection on train to the point where it strikes the ground.

A. 90 m

B. $90(\sqrt{3})$ m

C. 60 m

D. $60(\sqrt{3})$ m

Answer: A



Watch Video Solution

14. A body is projected at time $t = 0$ from a certain point on a planet's surface with a certain velocity at a certain angle with the planet's surface (assumed horizontal). The horizontal and vertical displacement x and y (in metre) respectively vary with time t in second as, $x = (10\sqrt{3})t$ and $y = 10t - t^2$.
The maximum height attained by the body is

A. 75 m

B. 100 m

C. 50 m

D. 25 m

Answer: D



Watch Video Solution

15. A particle is fired horizontally from an inclined plane of inclination 30° with horizontal with speed 50ms^{-1} . If

$g = 10\text{ms}^{-2}$, the range measured along the
incline is

A. 500m

B. $\frac{1000}{3}\text{m}$

C. $200(\sqrt{2})\text{m}$

D. $100(\sqrt{3})\text{m}$

Answer: B



Watch Video Solution

16. A fixed mortar fires a bomb at an angle of 53° above the horizontal with a muzzle velocity of 80ms^{-1} . A tank is advancing directly towards the mortar on level ground at a constant speed of 5m/s . The initial separation (at the instant mortar is fired) between the mortar and tank, so that the tank would be hit is $[Take\ g = 10\text{ms}^{-2}]$

A. 662.4m

B. 526.3m

C. 486.6m

D. None of these

Answer: D



Watch Video Solution

Level 1 Subjective

1. At time $t = 0$, a small ball is projected from point A with a velocity of 60m/s at 60° angle with horizontal. Neglect atmospheric resistance and determine the two times

t_1 and t_2 when the velocity of the ball makes an angle of 45° with horizontal x-axis.



[Watch Video Solution](#)

2. A particle is projected from ground with velocity $20(\sqrt{2})\text{ m/s}$ at 45° . At what time particle is at height 15 m from ground?
($g = 10\text{ m/s}^2$)



[Watch Video Solution](#)

3. A particle is projected at an angle 60° with horizontal with a speed $v = 20\text{m/s}$. Taking $g = 10\text{m/s}^2$. Find the time after which the speed of the particle remains half of its initial speed.



[Watch Video Solution](#)

4. Two particles A and B are projected from ground towards each other with speeds 10m/s and $5(\sqrt{2})\text{m/s}$ at the angle

30° and 45° with horizontal from two points separated by a distance of 15 m.

will they collide or not ?

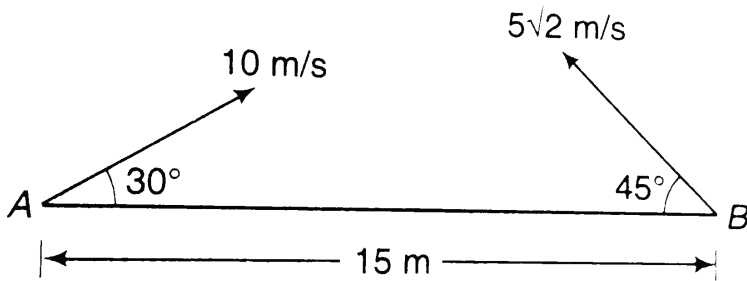

[Watch Video Solution](#)

5. Two particles move in a uniform gravitational field with an acceleration g . At the initial moment the particles were located

over a tower at one point and moved with velocities $v_1 = 3\text{ m/s}$ and $v_2 = 4\text{ m/s}$ horizontally in opposite directions. Find the distance between the particles at the moment when their velocity vectors become mutually perpendicular.



[Watch Video Solution](#)

6. A ball is thrown from the ground to clear a wall 3 m high at a distance of 6 m and falls 18

m away from the wall. Find the angle of projection of ball.



[Watch Video Solution](#)

7. A body is projected up such that its position vector varies with time as

$$r = \left\{ 3t\hat{i} + (4t - 5t^2)\hat{j} \right\} \text{ m. Here, } t \text{ is in}$$

seconds. Find the time and x-coordinate of particle when its y-coordinate is zero.



[Watch Video Solution](#)

8. A particle is projected along an inclined plane as shown in figure. What is the speed of the particle when it collides at point A ?

$$\left(g = 10 \frac{m}{s^2} \right)$$

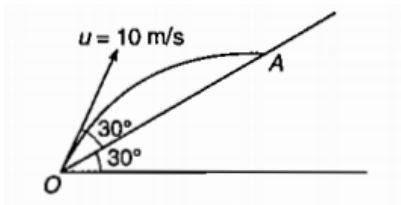

Watch Video Solution

9. In the above problem, what is the component of its velocity perpendicular to the plane when it strikes at A ?



Watch Video Solution

10. Two particles A and B are projected simultaneously from two towers of heights 10 m and 20m respectively. Particle A is projected with an initial speed of $10\sqrt{2}m/s$ at an angle of 45° with horizontal, while particle B is projected horizontally with speed $10m/s$. If

they collide in air, what is the distance d between the towers?

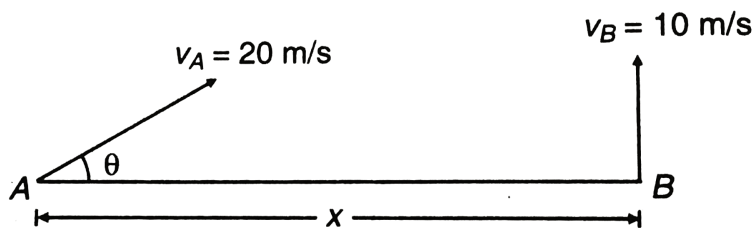

[Watch Video Solution](#)

11. A particle is projected from the bottom of an inclined plane of inclination 30° with velocity of 40 m/s at an angle of 60° with horizontal. Find the speed of the particle when

its velocity vector is parallel to the plane. Take

$$g = 10 \text{ m/s}^2.$$



[Watch Video Solution](#)

12. Two particles A and B are projected simultaneously in the directions shown in figure

with velocities

$v_A = 20 \text{ m/s}$ and $v_B = 10 \text{ m/s}$ respectively.

They collide in air after $\frac{1}{2}$ s. Find

(a) the angle θ

(b) the distance x .



Watch Video Solution

13. A ball is shot from the ground into the air.

At a height of 9.1 m, its velocity is observed to

be $v = 7.6\hat{i} + 6.1\hat{j}$ in metre per second (\hat{i} is

horizontal, \hat{j} is upward). Give the approximate

answers.

(a) To what maximum height does the ball

rise?

(b) What total horizontal distance does the ball travel?

(c) What are the magnitude and

(d) What are the direction of the ball's velocity just before it hits the ground?



[Watch Video Solution](#)

14. A particle is projected with velocity $2\sqrt{gh}$ so that it just clears two walls of equal height h which are at a distance $2h$ from each other.

Show that the time of passing between the walls is $2\sqrt{h/g}$.



[Watch Video Solution](#)

15. A particle is projected at an angle of elevation α and after t second it appears to have an elevation of β as seen from the point of projection. Find the initial velocity of projection.



[Watch Video Solution](#)

16. A projectile aimed at a mark, which is in the horizontal plane through the point of projection, falls a cm short of it when the elevation is α and goes b cm far when the elevation is β . Show that, if the speed of projection is same in all the cases the proper elevation is

$$\frac{1}{2} \sin^{-1} \left[\frac{b \sin 2\alpha + a \sin 2\beta}{a + b} \right].$$



Watch Video Solution

17. Two particles are simultaneously thrown in horizontal direction from two points on a riverbank, which are at certain height above the water surface. The initial velocities of the particles are $v_1 = 5\text{ m/s}$ and $v_2 = 7.5\text{ m/s}$ respectively. Both particles fall into the water at the same time. First particles enters the water at a point $s = 10\text{ m}$ from the bank.

Determine

(a) the time of flight of the two particles,

(b) the height from which they are thrown,

(c) the point where the second particle falls in water.



[Watch Video Solution](#)

18. A balloon is ascending at the rate $v = 12\text{km}/\text{h}$ and is being carried horizontally by the wind at $v_w = 20\text{km}/\text{h}$. If a ballast bag is dropped from the balloon at the instant $h = 50\text{ m}$, determine the time needed for it to strike the ground. Assume that the bag was released from the balloon with the same

velocity as the balloon. Also, find the speed with which the bag strikes the ground?



[Watch Video Solution](#)

19. A projectile is fired with a velocity u at right angles to the slope, which is inclined at an angle θ with the horizontal. Derive an expression for the distance R to the point of impact.



[Watch Video Solution](#)

20. An elevator is going up with an upward acceleration of 1 m/s^2 . At the instant when its velocity is 2 m/s , a stone is projected upward from its floor with a speed of 2 m/s relative to the elevator, at an elevation of 30° .

(a) Calculate the time taken by the stone to return to the floor.

(b) Sketch the path of the projectile as observed by an observer outside the elevator.

(c) If the elevator was moving with a

downward acceleration equal to g , how would the motion be altered?



[Watch Video Solution](#)

21. Two particles A and B are projected simultaneously in a vertical plane as shown in figure. They collide at time t in air. Write down two necessary equations for collision to take place.



[Watch Video Solution](#)

Level 2 Single Correct

1. Two bodies were thrown simultaneously from the same point, one straight up, and the other at an angle of $\theta = 30^\circ$ to the horizontal. The initial velocity of each body is 20m.s^{-1} . Neglecting air resistance, the distance between the bodies at $t = 1.2$ later is

A. (a)20 m

B. (b)30 m

C. (c)24 m

D. (d)50 m

Answer: C



Watch Video Solution

2. A particle is dropped from a height h . Another particle which is initially at a horizontal distance d from the first is simultaneously projected with a horizontal

velocity u and the two particles just collide on the ground. Then

A. $d^2 = \frac{u^2 h}{2h}$

B. $d^2 = \frac{2u^2 h}{g}$

C. $d = h$

D. $gd^2 = u^2 h$

Answer: B



Watch Video Solution

3. A ball is projected from point A with velocity 10m.s^{-1} perpendicular to the inclined plane as shown in figure. Range of the ball on the inclined plane is



A. $\frac{40}{3}m$

B. $\frac{20}{3}m$

C. $\frac{12}{3}m$

D. $\frac{60}{3}m$

Answer: A



Watch Video Solution

4. A heavy particle is projected with a velocity at an angle with the horizontal into the uniform gravitational field. The slope of the trajectory of the particle varies as

A. 

B. 

C. 

D. 

Answer: A



Watch Video Solution

5. A particle starts from the origin of coordinates at time $t = 0$ and moves in the xy plane with a constant acceleration α in the y -direction. Its equation of motion is $y = \beta x^2$.

Its velocity component in the x -direction is

A. (a) variable

B. (b) $\sqrt{\frac{2\alpha}{\beta}}$

C. (c) $\frac{\alpha}{2\beta}$

D. (d) $\sqrt{\frac{\alpha}{2\beta}}$

Answer: D



Watch Video Solution

6. A projectile is projected with speed u at an angle of 60° with horizontal from the foot of an inclined plane. If the projectile hits the inclined plane horizontally, the range on inclined plane will be.

A. $\frac{u^2(\sqrt{21})}{2g}$

B. $\frac{3u^2}{4g}$

C. $\frac{u^2}{2\beta}$

D. $\frac{(\sqrt{21})u^2}{8g}$

Answer: D



Watch Video Solution

7. Choose the correct option:

A particle is projected at an angle 60° with

speed $10(\sqrt{3})\text{ m/s}$, from the point A, as shown in the figure. At the same time the wedge is made to move with speed $10(\sqrt{3})\text{ m/s}$ towards right as shown in the figure. Then the time after which particle will strike with wedge is

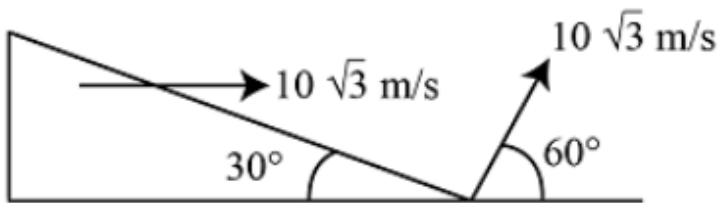

A. (a) 2 s

B. (b) $2(\sqrt{3})\text{ s}$

C. (c) $\frac{4}{\sqrt{3}}\text{ s}$

D. (d) None of these

Answer: A



Watch Video Solution

8. A particle moves along the parabolic path $x = y^2 + 2y + 2$ in such a way that Y-component of velocity vector remains $5ms^{-1}$ during the motion. The magnitude of the acceleration of the particle is

A. $50ms^{-2}$

B. $100ms^{-2}$

C. $10(\sqrt{2})ms^{-2}$

D. $0.1ms^{-2}$

Answer: A



Watch Video Solution

9. A shell fired from the base of a mountain just clears it. If α is the angle of projection,

then the angular elevation of the summit β is

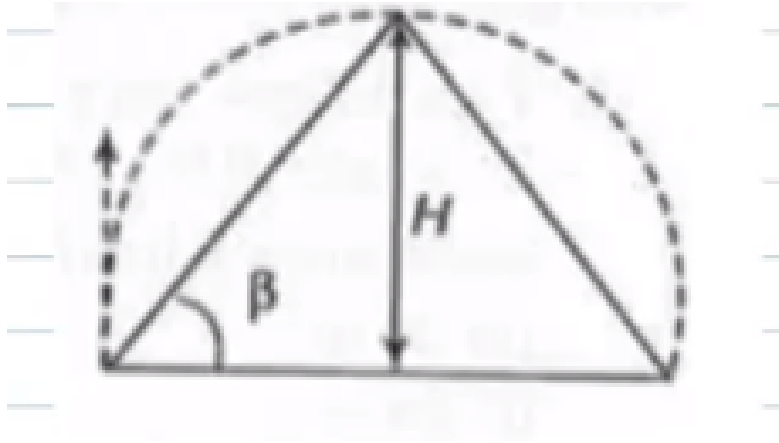

A. $\frac{\alpha}{2}$

B. $\tan^{-1}\left(\frac{1}{2}\right)$

C. $\tan^{-1}\left(\frac{\tan \alpha}{2}\right)$

D. $\tan^{-1}(2 \tan \alpha)$

Answer: C



10. In the figure shown, the two projectiles are fired simultaneously. The minimum distance between them during their flight is

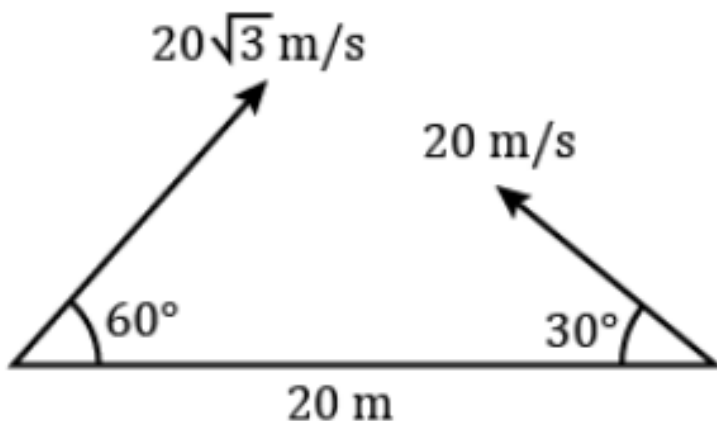

A. 20 m

B. $10(\sqrt{3}) \text{ m}$

C. 10 m

D. None of the above

Answer: B



Watch Video Solution

Level 2 More Than One Correct

1. Two particles projected from the same point with same speed u at angles of projection α and β strike the horizontal ground at the

same point. If h_1 and h_2 are the maximum heights attained by the projectile, R is the range for both and t_1 and t_2 are their times of flights, respectively, then

A. (a) $\alpha + \beta = \frac{\pi}{2}$

B. (b) $R = 4\left(\sqrt{h_1 h_2}\right)$

C. (c) $\frac{t_1}{t_2} = \tan \alpha$

D. (d) $\tan \alpha = \left(\sqrt{\frac{h_1}{h_2}}\right)$

Answer: A::B::C::D



Watch Video Solution

2. A ball is dropped from a height of 49 m. The wind is blowing horizontally. Due to wind a constant horizontal acceleration is provided to the ball. Choose the correct statement (s).

A. Path of the ball is a straight line

B. Path of the ball is a curved one

C. The time taken by the ball to reach the ground is 3.16 s

D. Actual distance travelled by the ball is more than 49 m.

Answer: A::C::D



Watch Video Solution

3. A particle is projected from a point P with a velocity v at an angle θ with horizontal. At a certain point Q it moves at right angles to its initial direction. Then

A. velocity of particle at Q is $v \sin \theta$

B. velocity of particles at Q is $v \cot \theta$

C. time of flight from $P \rightarrow Q$ is

$$(v/g) \cos \theta$$

D. time of flight from $P \rightarrow Q$ is $(v/g) \sec \theta$

Answer: B::C



Watch Video Solution

4. At a height of 15 m from ground velocity of a projectile is $v = (10\hat{i} + 10\hat{j})$. Here \hat{j} is vertically upwards and \hat{i} is along horizontal direction then ($g = 10 \text{ m s}^{-2}$)

A. particle was projected at an angle of 45° with horizontal.

B. time of flight of projectile is 4 s

C. horizontal range of projectile is 100 m

D. maximum height of projectile from ground is 20 m.

Answer: B::D



Watch Video Solution

5. Which of the following quantities remain constant during projectile motion?

A. Average velocity between two points

B. Average speed between two points

C. $\frac{dv}{dt}$

D. $\frac{d^2v}{dt^2}$

Answer: C::D



Watch Video Solution

6. In the projectile motion shown is figure,
given $t_{AB} = 2s$ then ($g = 10ms^{-2}$)



A. particle is at point B at 3 s

B. maximum height of projectile is 20 m

C. initial vertical component of velocity is

$$20ms^{-1}$$

D. horizontal component of velocity is

$$20ms^{-1}$$

Answer: A::B::C::D



Watch Video Solution

7. Two inclined planes OA and OB intersect in a horizontal plane having their inclinations α and β with the horizontal as shown in figure. A particle is projected from P with velocity u along a direction perpendicular to

plane OA. The particle strikes plane OB perpendicularly at Q.

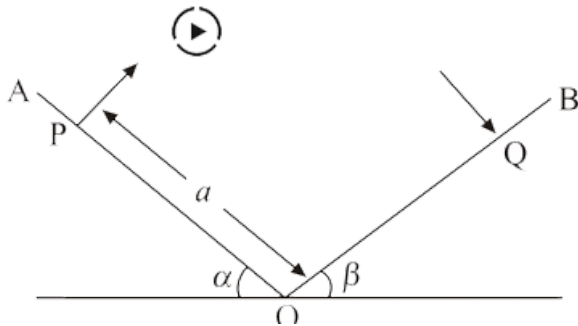

If $\alpha = 30^\circ$, $\beta = 30^\circ$ the time of flight from P to Q is

- A. $\frac{u}{g}$
- B. $\frac{(\sqrt{3})u}{g}$
- C. $\frac{(\sqrt{2})u}{g}$

D. $\frac{2u}{g}$

Answer: B



Watch Video Solution

8. Two inclined planes OA and OB intersect in a horizontal plane having their inclinations α and β with the horizontal as shown in figure. A particle is projected from P with velocity u along a direction perpendicular to plane OA. The particle strikes plane OB

perpendicularly at Q.

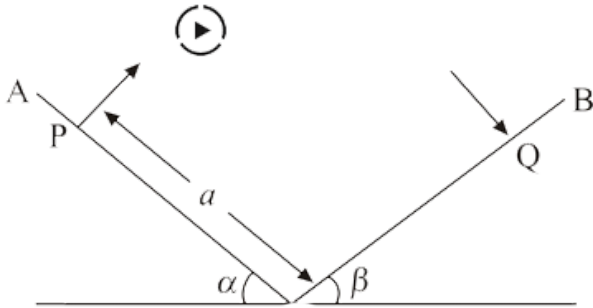

If $\alpha = 30^\circ$, $\beta = 30^\circ$ and $a = 4.9$ m, the initial velocity of projection is

A. $9.8ms^{-1}$

B. $4.9ms^{-1}$

C. $4.9(\sqrt{2})ms^{-1}$

D. $19.6ms^{-1}$

Answer: A



Watch Video Solution

Level 2 Subjective

1. Determine the horizontal velocity v_0 with which a stone must be projected horizontally from a point P, so that it may hit the inclined plane perpendicularly. The inclination of the plane with the horizontal is θ and point P is at a height h above the foot of the incline, as

shown in the figure.

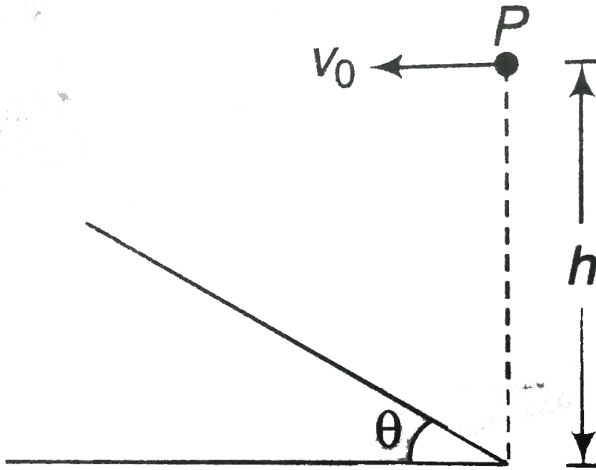

[▶ Watch Video Solution](#)

2. A particle is dropped from point P at time $t = 0$. At the same time another particle is thrown from point O as shown in the figure and it

collides with the particle P. Acceleration due to gravity is along the negative y-axis. If the two particles collide 2 s after they start, find the initial velocity v_0 of the particle which was projected from O. Point O is not necessarily on ground.

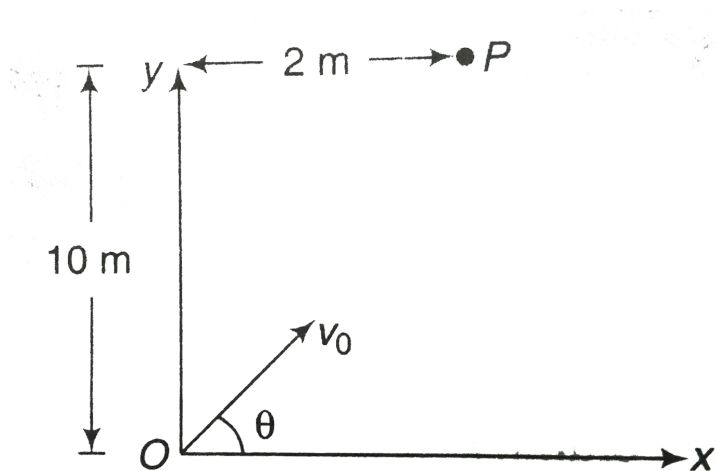

[Watch Video Solution](#)

3. Two particles are simultaneously projected in the same vertical plane from the same point with velocities u and v at angles α and β with horizontal. Find the time that elapses when their velocities are parallel.



[Watch Video Solution](#)

4. A projectile takes off with an initial velocity of 10 m/s at an angle of elevation of 45° . It is just able to clear two hurdles of height 2 m

each, separated from each other by a distance d . Calculate d . At what distance from the point of projection is the first hurdle placed? Take $g = 10\text{m} / \text{s}^2$.



Watch Video Solution

5. A stone is projected from the ground in such a direction so as to hit a bird on the top of a telegraph post of height h and attains the maximum height of $2h$ above the ground. If at the instant of projection, the bird were to fly

away horizontally with a uniform speed, find the ratio between the horizontal velocity of bird and the horizontal component of velocity of stone, if the stone hits the bird while descending.



[Watch Video Solution](#)

6. A particle is released from a certain height $H = 400m$. Due to the wind, the particle gathers the horizontal velocity component $v_x = ay$ where $a = (\sqrt{5})s^{-1}$ and y is the

vertical displacement of the particle from the point of release, then find

(a) the horizontal drift of the particle when it strikes the ground ,

(b) the speed with which particle strikes the ground.



[Watch Video Solution](#)

7. A train is moving with a constant speed of $10\text{m} / \text{s}$ in a circle of radius $\frac{16}{\pi}$ m. The plane of the circle lies in horizontal x-y plane. At time t

$= 0$, train is at point P and moving in counter-clockwise direction. At this instant, a stone is thrown from the train with speed 10 m/s relative to train towards negative x-axis at an angle of 37° with vertical z-axis. Find

(a) the velocity of particle relative to train at the highest point of its trajectory.

(b) the co-ordinates of points on the ground where it finally falls and that of the highest point of its trajectory. (Take g

$$= 10m/s^2, \sin 37^\circ = \frac{3}{5}$$

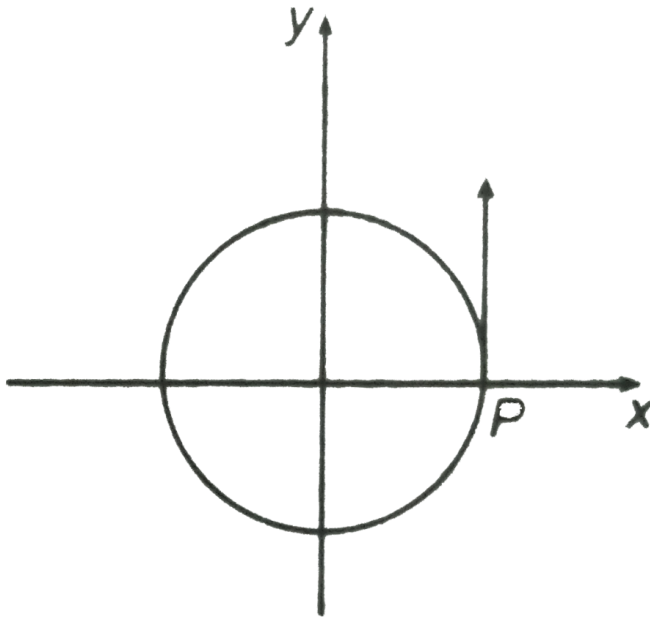

Watch Video Solution

8. A particle is projected from an inclined plane OP_1 from A with velocity $v_1 = 8ms^{-1}$ at an angle 60° with horizontal. An another particle is projected at the same instant from B with velocity $v_2 = 16ms^{-1}$ and perpendicular to the plane OP_2 as shown in figure. After time $10(\sqrt{3})$ s there separation was minimum and found to be 70m. Then find

distance AB.

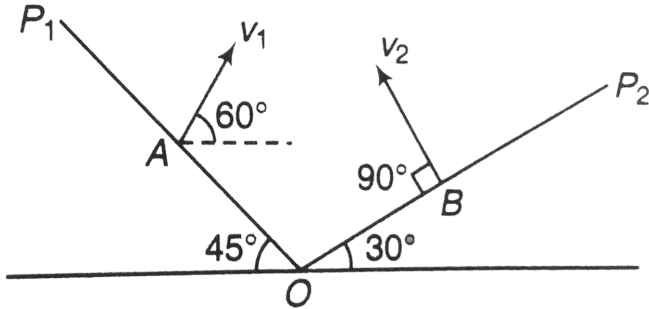

Watch Video Solution

9. A particle is projected from point O on the ground with velocity $u = 5(\sqrt{5})\text{ m/s}$ at angle $\alpha = \tan^{-1}(0.5)$. It strikes at a point C on a fixed smooth plane AB having inclination of 37° with horizontal as shown in figure. If the

particle does not rebound, calculate.

(a) coordinates of point C in reference to coordinate system as shown in the figure.

(b) maximum height from the ground to which the particles rises. ($g = 10 \text{ m/s}^2$)

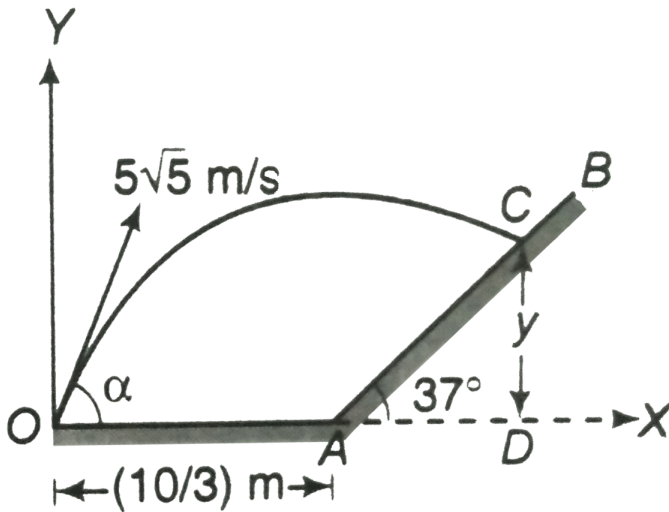

[Watch Video Solution](#)

10. A plank fitted with a gun is moving on a horizontal surface with speed of 4 m/s along the positive x-axis. The z-axis is in vertically upward direction. The mass of the plank including the mass of the gun is 50 kg. When the plank reaches the origin, a shell of mass 10 kg is fired at an angle of 60° with the positive x-axis with a speed of $v = 20\text{ m/s}$ with respect to the gun in x-z plane. Find the position vector of the shell at $t=2\text{ s}$ after firing it. Take $g = 9.8\text{ m/s}^2$.



Watch Video Solution

