



## PHYSICS

### BOOKS - DC PANDEY ENGLISH

#### PROPERTIES OF MATTER

Jee Main

1. In a hydraulic lift at a service station, the radii of the large and small piston are in the ratio of 20 : 1. What weight placed on the small piston will be sufficient to lift a car of mass 1200 kg ?

A. 3.75 Kg

B. 37.5 kg

C. 7.5 kg

D. 75 kg

**Answer: A**

 [Watch Video Solution](#)

2. Two vessels  $A$  and  $B$  of different shapes have the same base area and are filled with water up to the same height  $h$  (see figure). The force exerted by water on the base is  $F_A$  for vessel  $A$  and  $F_B$  for vessel  $B$ . The respective weights of the

water filled in vessels are  $W_A$  and  $W_B$ . Then

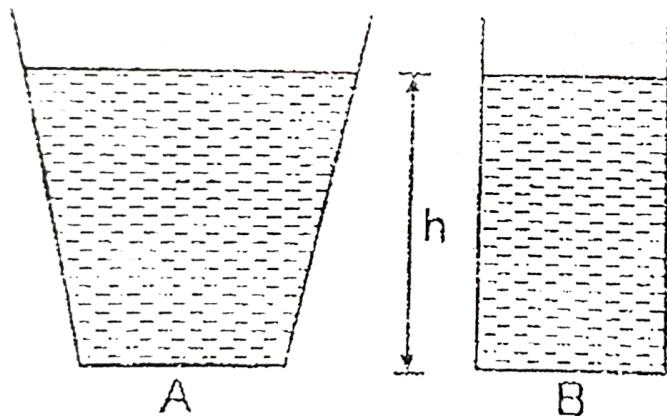

A.  $F_A > F_B, w_A > w_B$

B.  $F_A = F_B, w_A > w_B$

C.  $F_A = F_B, w_A < w_B$

D.  $F_A > F_B, w_A = w_B$

**Answer: B**



**Watch Video Solution**

3. The reading of a spring balance when a block is suspended from it in air is 60 N. This reading is changed to 40 N when the block is submerged in water. The relative density of the block is:

A. 3

B. 2

C. 6

D.  $\frac{3}{2}$

**Answer: A**



**Watch Video Solution**

4. The velocity of the liquid coming out of a small hole of a vessel containing two different liquids of densities  $2\rho$  and  $\rho$  as shown in the figure is

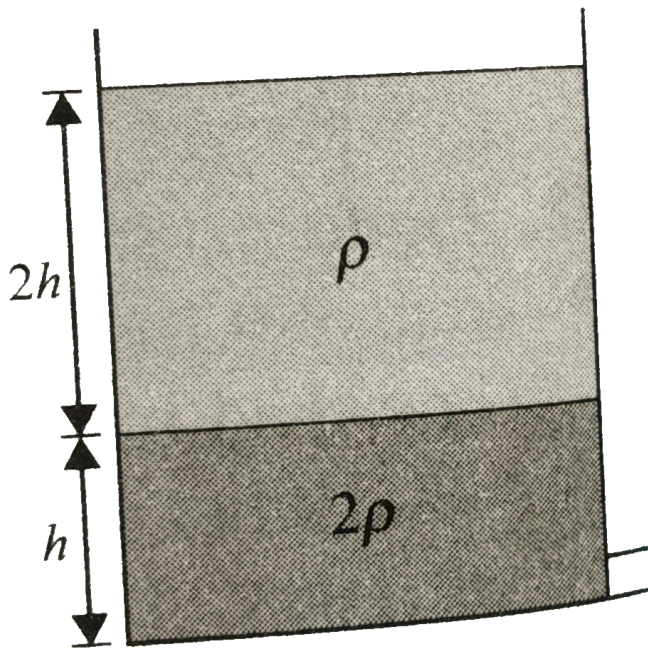

Fig. 4.1

A.  $\sqrt{6gh}$

B.  $2\sqrt{gh}$

C.  $2\sqrt{2gh}$

D.  $\sqrt{gh}$

**Answer: B**



**Watch Video Solution**

5. A block of silver of mass  $4kg$  hanging from a string is immersed in a liquid of relative density 0.72. If relative density of silver is 10, then tension in the string will be

A. 37.12 N

B. 42 N

C. 73 N

D. 21 N

**Answer: A**



**Watch Video Solution**

6. Figure shows water filled in a symmetrical container. Four pistons of equal area  $A$  are used at the four openings to keep the water in equilibrium. Now an additional force  $F$  is applied at each piston. The increase in the pressure at the

centre of the container due to this addition is

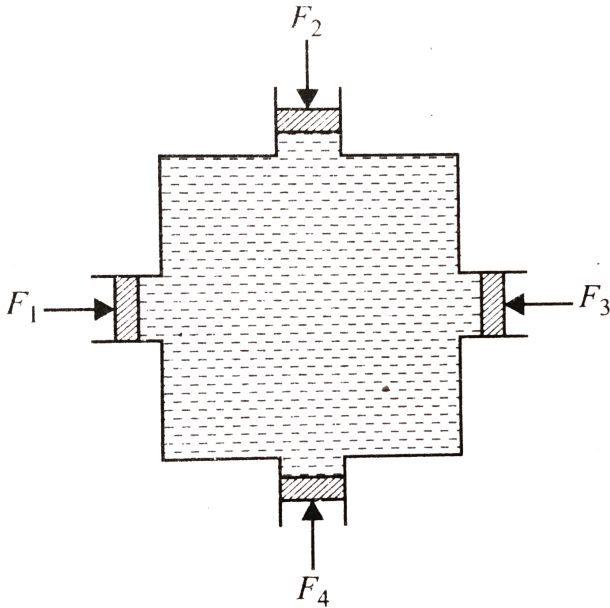

A.  $\frac{F}{A}$

B.  $\frac{2F}{A}$

C.  $\frac{4F}{A}$

D. 0

Answer: A



Watch Video Solution



7. The radii of the two columns in U-tube are  $r_1$  and  $r_2$  ( $r_2 > r_1$ ). When a liquid of density  $\rho$  (angle of contact is  $0^\circ$ ) is filled in it, the level difference of liquid in two arms is  $h$ . The surface tension of liquid is  $(g = \text{acceleration due to gravity})$

A.  $\frac{\rho g h r_1 r_2}{2(r_2 - r_1)}$

B.  $\frac{\rho g h (r_2 - r_1)}{2r_1 r_2}$

C.  $\frac{2(r_2 - r_1)}{\rho g h r_1 r_2}$

D.  $\frac{\rho g h}{2(r_2 - r_1)}$

**Answer: A**



**Watch Video Solution**

8. A capillary tube of radius  $R$  is immersed in water and water rises in it to a height  $H$ . Mass of water in the capillary tube is  $M$ . If the radius of the tube is doubled, mass of water that will rise in the capillary tube will now be

A.  $2M$

B.  $M$

C.  $8M$

D.  $4M$

**Answer: A**



**Watch Video Solution**

9. A water drop is divided into eight equal droplets. The pressure difference between inner and outer sides of big drop is

A. same as that for smaller droplet

B.  $1/2$  of that for smaller droplet

C.  $1/4$  of that for smaller droplet

D. twice of that for smaller droplet

**Answer: B**



**Watch Video Solution**

10. An air bubble of radius  $r$  in water is at a depth  $h$  below the water surface at some instant. If  $P$  is atmospheric

pressure,  $d$  and  $T$  are density and surface tension of water respectively . the pressure inside the bubble will be :

A.  $p + hdg - \frac{4T}{r}$

B.  $p + hdg + \frac{2T}{r}$

C.  $p + hdg - \frac{2T}{r}$

D.  $p + hdg + \frac{4T}{r}$

**Answer: B**

 [Watch Video Solution](#)

**11.** At critical temperature, the surface tension of a liquid

A. is zero

B. is infinity

C. is same as that it has at any other temperature

D. Cannot be determined

**Answer: A**



**Watch Video Solution**

12. A mass  $m$  is suspended from a wire . Change in length of the wire is  $\Delta l$ . Now the same wire is stretched to double its length and the same mass is suspended from the wire. The change in length in this case will become (it is suspended that elongation in the wire is within the proportional limit)

A.  $\Delta l$

B.  $2\Delta l$

C.  $4\Delta l$

D.  $8\Delta l$

**Answer: C**



**Watch Video Solution**

13. A glass capillary tube of inner diameter 0.28 mm is lowered vertically into water in a vessel. The pressure to be applied on the water in the capillary tube so that water level in the tube is same as the vessel in  $\frac{N}{m^2}$  is (surface tension of water =  $0.07 \frac{N}{m}$  atmospheric pressure =  $10^5 \frac{N}{m^2}$ )

A.  $10^3$

B.  $10^6$

C.  $10^4$

D.  $10^5$

**Answer: A**



**Watch Video Solution**

**14.** What will the effect on the temperature, if the number of small drops of mercury coalesce adiabatically to form a single drop?

A. increase

B. remain same

C. decrease

D. depend on size

Answer: A

 Watch Video Solution

15. The area of cross-section of the wider tube shown in fig., is  $800\text{cm}^2$ . If a mass of 12 kg is placed on the massless piston, what is the difference in the level of water in two tubes.

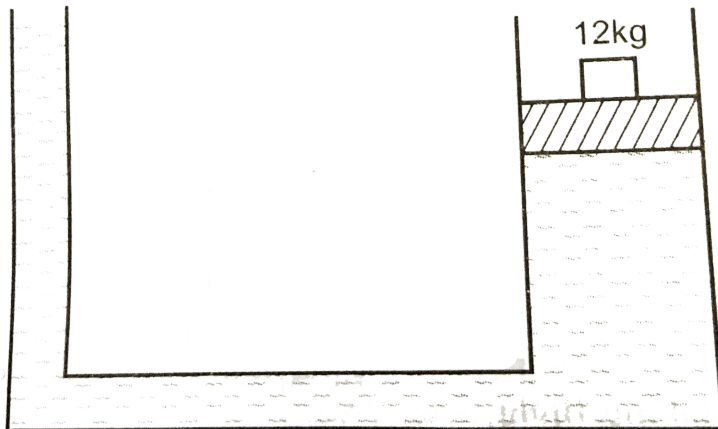

A. 10 cm



B. 6 cm

C. 15 cm

D. 2 cm

**Answer: C**



**Watch Video Solution**

**16.** An open -ended U-tube of uniform cross-sectional area contains water (density  $1.0g/cm^3$ ) standing initially 20 cm from the bottom in each arm. An immiscible liquid of density  $4.0g/cm^3$  is added to one arm until a layer 5 cm high forms, as shown in the figure above. What is the ratio  $h_2/h_1$  of the

heights of the liquid in the two arms ?

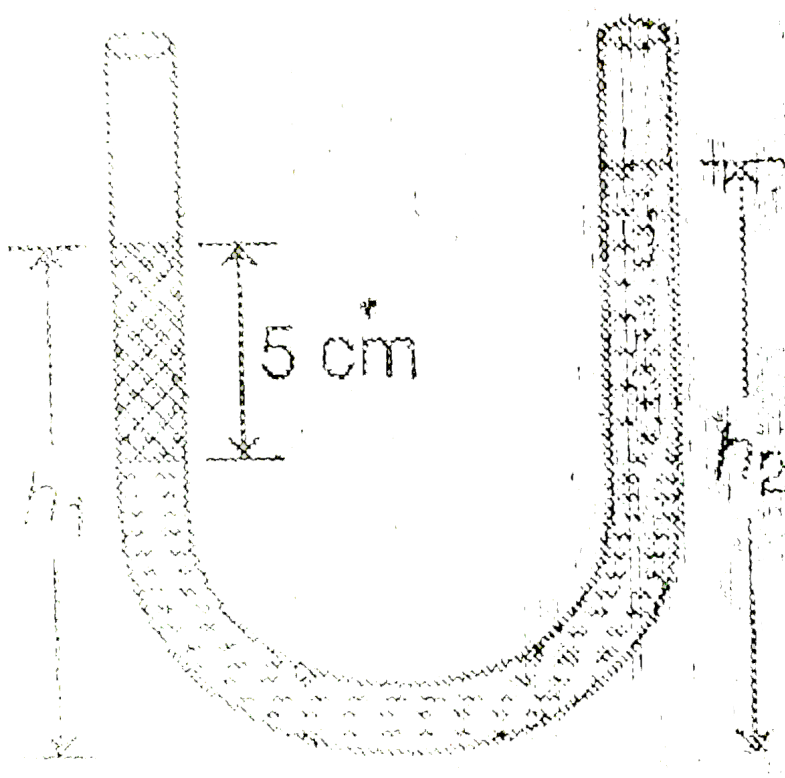

A. 3/1

B. 5/2

C. 2/1

D. 3/2

**Answer: C**



**Watch Video Solution**

17. A beaker containing water is placed on the platform of a spring balance. The balance reads  $1.5\text{kg}$ . A stone of mass  $0.5\text{kg}$  and density  $10^4\text{kg}/\text{m}^3$  is immersed in water without touching the walls of the beaker. What will be the balance reading now?

- A. 2 kg
- B. 2.5 kg
- C. 1 kg
- D. 3 kg

Answer: B

 Watch Video Solution

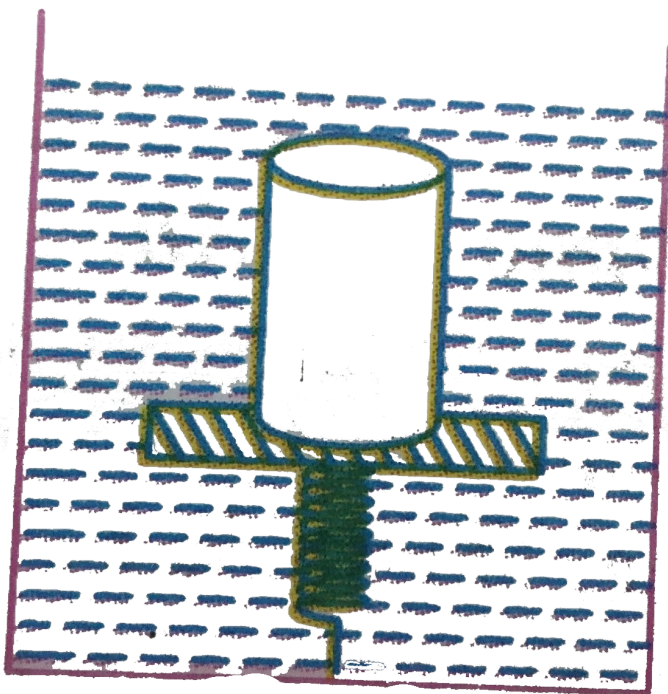

18.

Cylindrical block of area of cross-section  $A$  and of material of density  $\rho$  is placed in a liquid of density one third of density of block. The block compress in the spring is one-third of the

length of the block. if acceleration due to gravity is  $g$ , the spring constant of the spring is

A.  $\rho Ag$

B.  $2\rho Ag$

C.  $2\rho Ag/3$

D.  $\rho Ag/3$

**Answer: B**



[Watch Video Solution](#)

**19.** A jet of water with cross section of  $6\text{cm}^2$  strikes a wall at an angle of  $60^\circ$  to the normal and rebounds elastically from the wall without losing energy. If the velocity of the water in the jet is  $12\text{m/s}$ , the force acting on the wall is

A. 0.864 N

B. 86.4 N

C. 72 N

D. 7.2 N

**Answer: B**

 [Watch Video Solution](#)

**20.** The cross sectional area of a horizontal tube increases along its length linearly, as we move in the direction of flow. The variation of pressure, as we move along its length in the direction of flow (x-direction), is best depicted by which of the following graphs.

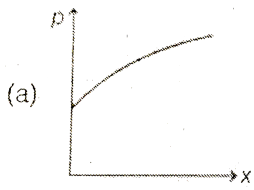

A.

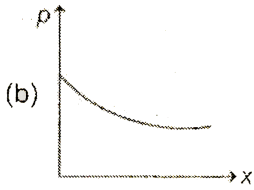

B.

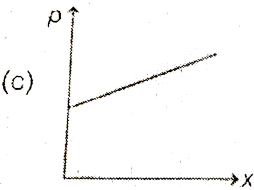

C.

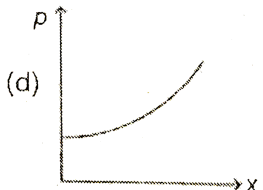

D.

**Answer: A**



**Watch Video Solution**

21. A solid metallic sphere of radius  $r$  is allowed to fall freely through air. If the frictional resistance due to air is proportional to the cross-sectional area and to the square of the velocity, then the terminal velocity of the sphere is proportional to which of the following ?

A.  $r^2$

B.  $r$

C.  $r^{3/2}$

D.  $r^{1/2}$

**Answer: D**



**Watch Video Solution**



22. There is a 1mm thick layer of glycerine between a flat plate of area  $100\text{cm}^2$  and a big plate. If the coefficient of viscosity of glycerine is  $1.0\text{kg}/\text{m} - \text{sec}$ , then how much force is required to move the plate with a velocity of 7 cm/sec.

A. 3.5 N

B. 0.7 N

C. 1.4 N

D. None of these

**Answer: B**



**Watch Video Solution**

23. A metal ball  $B_1$  (density  $3.2g/cc$ ) is dropped in water, while another metal ball  $B_2$  (density  $6.0g/cc$ ) is dropped in a liquid of density  $1.6g/cc$ . If both the balls have the same diameter and attain the same terminal velocity, the ratio of viscosity of water to that of the liquid is

- A. 2
- B. 0.5
- C. 4
- D. 0.25

**Answer: B**



**Watch Video Solution**

24. A wooden cube floating in water supports a mass 0.2 kg on its top. When the mass is removed the cube rises by 2cm. What is the side length of the cube ? Density of water =  $10^3 \text{ kg/m}^3$

- A. 6 cm
- B. 12 cm
- C. 8 cm
- D. 10 cm

**Answer: D**



**Watch Video Solution**

25. A block of volume  $V$  and density  $\rho$  is floating in a liquid of density  $2\rho$  filled in a vessel. Now the vessel starts falling freely with acceleration  $g$ . Then the volume of block inside the liquid in the falling condition is

- A.  $V$
- B.  $V/2$
- C. arbitray
- D. zero

**Answer: C**



**Watch Video Solution**

26. A solid shell loses half of its weight in water. Relative density of shell is 5.0 What fraction of its volume is hollow ?

A.  $\frac{3}{5}$

B.  $\frac{2}{5}$

C.  $\frac{1}{5}$

D.  $\frac{4}{5}$

**Answer: A**



**Watch Video Solution**

27. Force constant of a spring ( $k$ ) is anonymous to

A.  $\frac{YA}{L}$

B.  $\frac{YL}{A}$

C.  $\frac{AL}{Y}$

D.  $ALY$

**Answer: A**



**Watch Video Solution**

**28.** Two wires A and B have the same length and area of cross-section. But Young's modulus of A is two times the Young's modulus of B. Then the ratio of force constant of A to that of B is

A. 1

B. 2

C.  $1/2$

D.  $\sqrt{2}$

**Answer: B**

 [Watch Video Solution](#)

**29.** A body floats in a liquid contained in a beaker. The whole system as shown in the figure falls freely under gravity. The upthrust on the body is

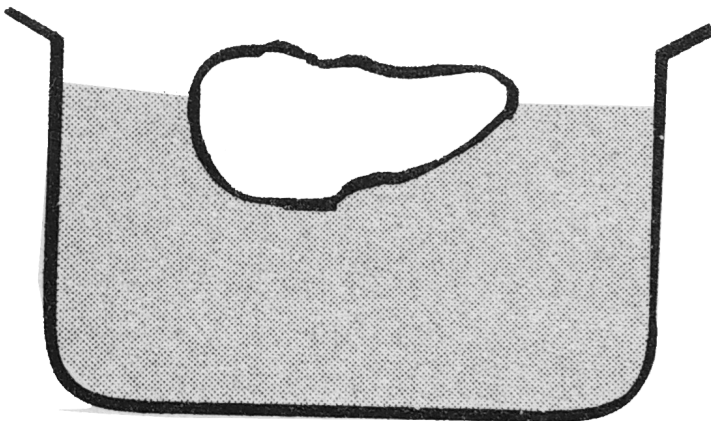

A. zero

B. equal to the weight of the liquid displaced

C. less than the weight of the liquid displaced

D. equal to the weight of the immersed portion of the  
body

**Answer: C**



**Watch Video Solution**

**30.** A piece of steel has a weight  $w$  in air,  $w_1$  when completely immersed in water and  $w_2$  when completely immersed in an unknown liquid. The relative density (specific gravity) of liquid is



A.  $\frac{w - w_1}{w - w_2}$

B.  $\frac{w - w_2}{w - w_1}$

C.  $\frac{w_1 - w_2}{w - w_1}$

D.  $\frac{w_1 - w_2}{w - w_2}$

**Answer: B**



**Watch Video Solution**

**31.** A ball of relative density 0.8 falls into water from a height of 2 m. find the depth to which the ball will sink (neglect viscous forces)

A. 8 m

B. 2 m

C. 6 m

D. 4 m

**Answer: A**



**Watch Video Solution**

**32.** A cubical block of wood of specific gravity 0.5 and chunk of concrete of specific gravity 2.5 are fastened together. the ratio of mass of wood to the mass of concrete which makes the combination to float with entire volume of the combination submerged in water is

A.  $\frac{5}{3}$

B.  $\frac{6}{5}$

C.  $\frac{5}{2}$

D.  $\frac{4}{3}$

**Answer: A**



**Watch Video Solution**

**33.** Consider the barometer shown in figure. Density of mercury is  $\rho$ . A small hole is made at point S as shown. The

mercury come out from this hole with speed  $v$  equal to

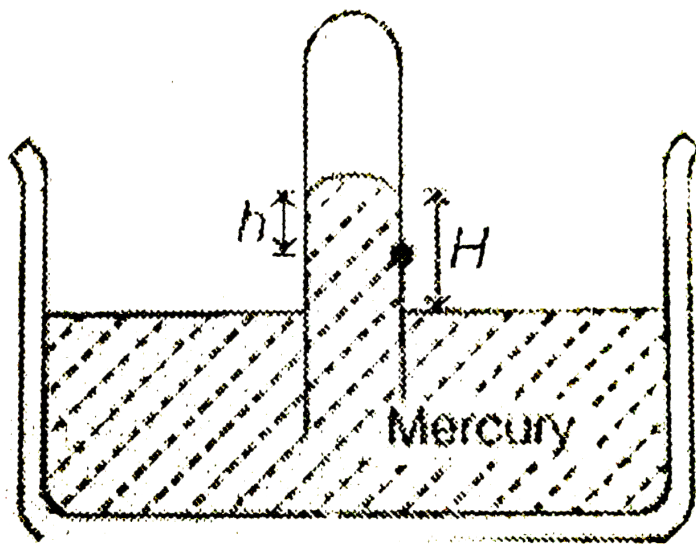

A.  $\sqrt{2gh}$

B.  $\sqrt{2gH}$

C.  $\sqrt{2g(H - h)}$

D. None of these

Answer: b



Watch Video Solution

**34.** A satellite revolves round the earth. Air pressure inside the satellite is maintained at 76 cm of mercury. What will be the height of mercury column in a barometer tube 1m long placed in the satellite?

A. 76 cm

B. 90 cm

C. zero

D. None of these

**Answer: B**



**Watch Video Solution**

35. A barometer tube reads 76 cm of mercury. If the tube is gradually inclined at an angle of  $60^\circ$  with vertical, keeping the open end immersed in the mercury reservoir, the length of the mercury column will be

- A. 152 cm
- B. 76 cm
- C. 38 cm
- D.  $38\sqrt{3} \text{ cm}$

**Answer: A**



**Watch Video Solution**

36. Two liquids which do not react chemically are placed in a bent tube as shown in the figure. The heights of the liquids above their surface of separation are

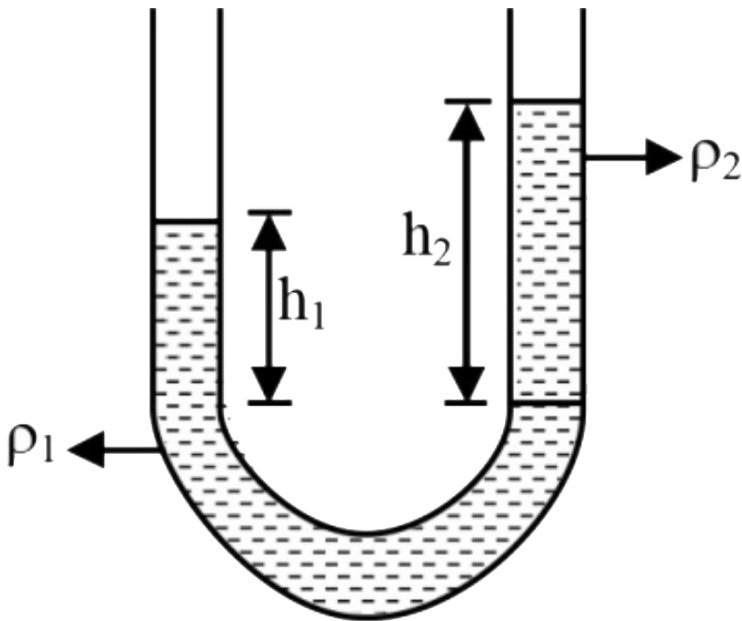

- A. directly proportional to their densities
- B. inversely proportional to their densities
- C. directly proportional to square of their densities

D. equal

**Answer: B**



**Watch Video Solution**

**37.** A rubber balloon has 200 g of water in it. Its weight in water will be (neglect the weight of balloon)

A. 100 g

B. 200 g

C. 50 g

D. zero

**Answer: D**



**Watch Video Solution**



38. Mercury is poured in a U-tube. Temperature of one side is  $50^\circ C$  and level of mercury on this side is  $h_2$ . Temperature of the other side of  $100^\circ C$  and level of mercury on this side is  $h_1$ . Then

A.  $h_1 = h_2$

B.  $h_2 < h_1$

C.  $h_2 > h_1$

D.  $h_2 = 2h_1$

**Answer: C**



39. A closed compartment containing gas is moving with some acceleration in horizontal direction. Neglect effect of gravity. Then the pressure in the compartment is

- A. same everywhere
- B. lower in front side
- C. lower in rear side
- D. lower in upper side

**Answer: B**



[Watch Video Solution](#)

40. The height of a mercury barometer is 75 cm at sea level and 50 cm at the top of a hill. Ration of density of mercury

to that of air is  $10^4$ . The height of the hill is

- A. 250 m
- B. 2.5 km
- C. 1.25 km
- D. 750 m

**Answer: B**



**Watch Video Solution**

**41.** In case of a liquid

- A. only bulk modulus is defined
- B. only bulk modulus and Young's modulus are defined

C. only bulk modulus and shear modulus are defined

D. all the three moduli (bulk, Young's and shear) are defined

**Answer: A**

 [Watch Video Solution](#)

**42.** Which of the following is not the unit of surface tension ?

A.  $N/m$

B.  $J/m^2$

C.  $kg/s^2$

D. None of these

**Answer: D**



**Watch Video Solution**

**43.** A water proofing agent changes the angle of contact from

- A. acute to  $90^\circ$
- B. obtuse to  $90^\circ$
- C. an acute to obtuse angle
- D. an obtuse to an acute angle

**Answer: C**



**Watch Video Solution**

44. A metallic wire of diameter  $d$  is lying horizontally on the surface of water. The maximum length of wire so that it may not sink will be

A.  $\sqrt{\frac{2T}{\pi\rho g}}$

B.  $\sqrt{\frac{4T}{\rho g}}$

C.  $\sqrt{\frac{T}{\pi\rho g}}$

D.  $\sqrt{\frac{T\rho}{\pi g}}$

**Answer: A**



**Watch Video Solution**

45. The water proofing agents:

- A. increase the surface tension  $T$  and decrease the angle of contact  $\theta$
- B. increase both  $T$  and  $\theta$
- C. decrease both  $T$  and  $\theta$
- D. decrease  $T$  and increase  $\theta$

**Answer: B**



**Watch Video Solution**

**46.** What is the radius of a steel sphere that will float on water with exactly half the sphere submerged? Density of steel is  $7.9 \times 10^3 \text{ kg/m}^3$  and surface tension of water is  $7 \times 10^{-2} \text{ N}$ .

- A. 2.6 cm
- B. 4.6 mm
- C. 1.2 mm
- D. 6.5 mm

**Answer: C**

 [Watch Video Solution](#)

**47.** A capillary is dipped in water vessel kept on a freely falling lift, then

- A. water will not rise in the tube
- B. water will rise to the maximum available height of the tube



C. water will rise to the height observed under normal condition

D. water will rise to the height below that observed under normal condition

**Answer: B**

 [Watch Video Solution](#)

**48.** A and B are two soap bubbles. Bubble A is larger than B.

If these are now joined by a tube then

A. the bubble A becomes more large

B. the bubble B becomes more large

C. both the bubbles acquire the same size

D. both the bubbles will get bursted

**Answer: A**



**Watch Video Solution**

**49.** Two drops of same radius are falling through air with steady speed  $v$ . If the two drops coalesce, what would be the terminal speed –

A.  $v$

B.  $2v$

C.  $3v$

D. None of these

**Answer: D**



[Watch Video Solution](#)

50. If a million tiny droplets of water of the same radius coalesce into one larger drop, the ration of the surface energy of the large drop to the total surface energy of all the droplets will be

A. 1: 10

B. 1:  $10^2$

C. 1:  $10^4$

D. 1:  $10^6$

**Answer: B**



[Watch Video Solution](#)

51. If viscosity of air is taken into account, then the orbital velocity of the satellite moving close to earth

A. increases till the satellite moving close to earth

B. increases till the satellite overcomes earth's gravitational pull

C. decrease continuously

D. remains unaffected

**Answer: A**



**Watch Video Solution**

52. The amount of work done in forming a soap bubble of radius  $r = 1\text{cm}$  (surface tension  $T = 3 \times 10^{-2}\text{N/m}$ ) is

A.  $37.38\mu\text{J}$

B.  $40.20\mu\text{J}$

C.  $75.36\mu\text{J}$

D.  $20.10\mu\text{J}$

**Answer: C**



**Watch Video Solution**

53. Choose the wrong alternative.

A. Detergents should have small angles of contact

B. Surface tension of liquid is independent of the area of the surface

C. A drop of liquid under no external forces (other than surface tension) is always spherical in shape.

D. None of these

**Answer: D**



**Watch Video Solution**

**54.** If  $\eta$  represents the coefficient of viscosity and  $T$  the surface tension. Then the dimensions of  $T/\eta$  are same as that of

A. length

B. mass

C. time

D. speed

**Answer: D**



**Watch Video Solution**

**55.** If a liquid neither rises nor depresses in a capillary then it means that

A. angle of contact is  $0^\circ$

B. angle of contact may be  $90^\circ$

C. surface tension of the liquid must be zero

D. None of these

**Answer: B**



**Watch Video Solution**

**56.** A soap bubble of radius  $r$  is placed on another bubble of radius  $2r$ . The radius of the surface common to both the bubbles is

A.  $\frac{2r}{3}$

B.  $3r$

C.  $2r$

D.  $r$

**Answer: C**



**Watch Video Solution**



57. water is filled in a tank as shown in figure. There is a hole from where liquid emerges with speed  $v$ . If air is blown over the tank, the speed  $v$

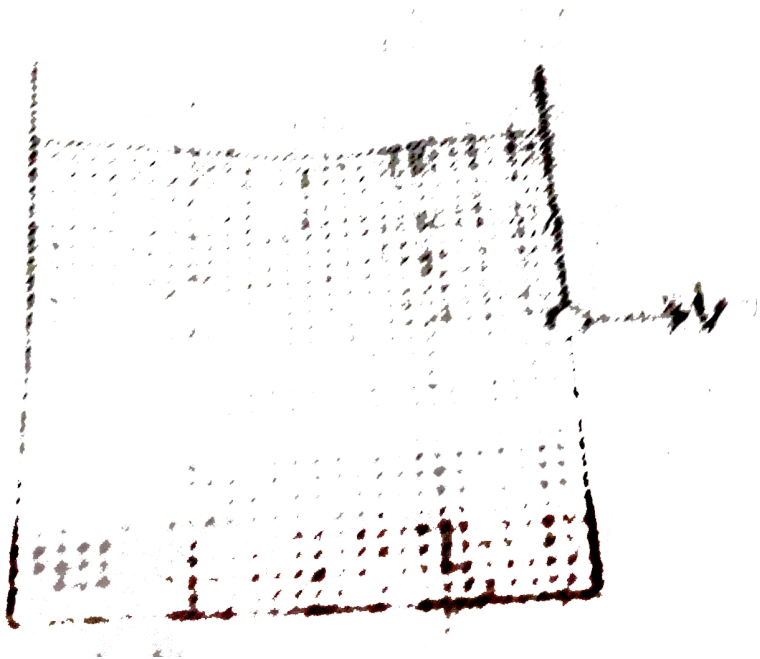

- A. will decrease
- B. will increase
- C. will remain same

D. may increase or decrease. It will depend on the density of the liquid

**Answer: A**

 [Watch Video Solution](#)

**58.** The pressure inside two soap bubbles is 1.01 and 1.02 atmospheres. The ratio of their respective volumes is

A. 102 : 101

B.  $(102^3) : (101)^3$

C. 8 : 1

D. 2 : 1

**Answer: B**



**Watch Video Solution**

**59.** A wooden block is floating in a liquid. About 50 % of its volume is inside the liquid when the vessel is stationary, Percentage volume immersed when the vessel moves upwards with acceleration  $a = \frac{g}{2}$  is

A. 75 %

B. 25 %

C. 50 %

D. 33.33 %

**Answer: C**

60. Two wires of equal length and cross-section area suspended as shown in figure. Their Young's modulus are  $Y_1$

and  $Y_2$  respectively. The equivalent Young's modulus will be

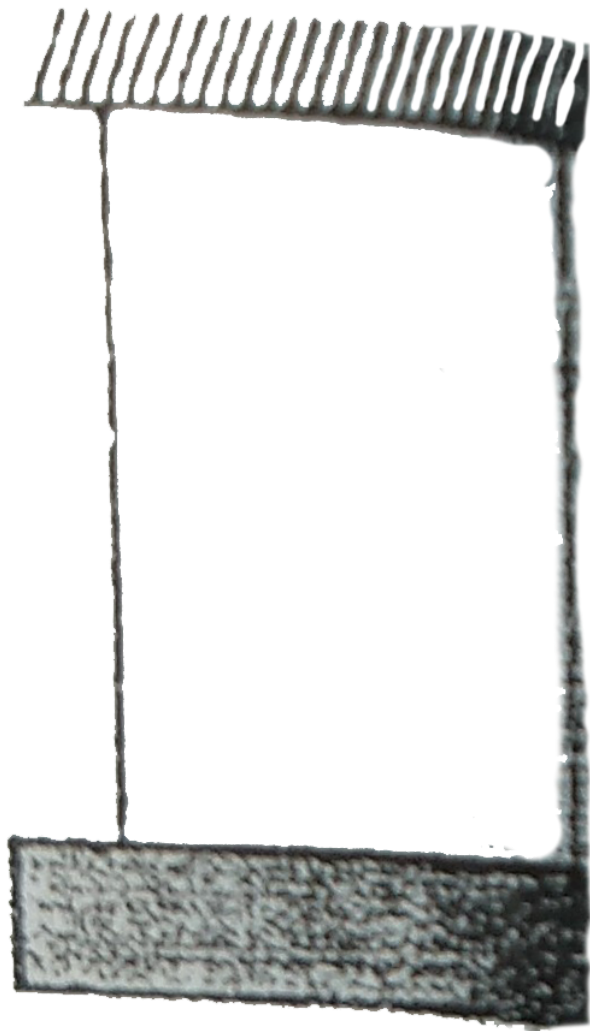

A.  $Y_1 + Y_2$

B.  $\frac{Y_1 + Y_2}{2}$

C.  $\frac{Y_1 Y_2}{Y_1 + y_2}$

D.  $\sqrt{Y_1 Y_2}$

**Answer: B**



**Watch Video Solution**

**61.** A spherical steel ball released at the top of along column of glycerin of length  $l$  falls through a distance  $l/2$  with accelerated motion and the remaining distance  $l/2$  with uniform velocity let  $t_1$  and  $t_2$  denote the times taken to cover the first and second half and  $w_1$  and  $w_2$  are the work done against gravity in the two halves, then compare times and work done.

A.  $t_1 < t_2, W_1 > W_2$

B.  $t_1 > t_2, W_1 < W_2$

C.  $t_1 = t_2, W_1 = W_2$

D.  $t_1 > t_2, W_1 = W_2$

**Answer: D**

 [Watch Video Solution](#)

**62.** The force required by a man to move his limbs immersed in water is smaller than the force for the some movement in air Why?

A. Both statement are correct

B. First statement is wrong, second is correct

C. First statement is correct, second is wronga

D. Both statement are wrong

**Answer: A**



**Watch Video Solution**

**63.** A ball of density  $\rho$  is released from deep inside of a liquid of density  $2\rho$ . It will move up

- A. with an increasing acceleration
- B. with a decreasing acceleration
- C. with a constant acceleration
- D. with zero acceleration

**Answer: B**



**Watch Video Solution**



64. The terminal velocity of a ball in air is  $v$ , where acceleration due to gravity is  $g$ . Now the same ball is taken in a gravity free space where all other conditions are same. The ball is now pushed at a speed  $v$ , then –

- A. the terminal velocity of the ball will be  $\frac{v}{2}$
- B. the ball will move with a constant velocity
- C. the initial acceleration of the ball is  $2g$  in opposite direction of the ball's velocity
- D. the ball will finally stop

**Answer: D**

65. In a cylindrical vessel containing liquid of density  $\rho$  there are two holes in the side walls at heights of  $h_1$  and  $h_2$  respectively such that the range of efflux at the bottom of the vessel is same. The height of a hole for which the range of efflux would be maximum, will be

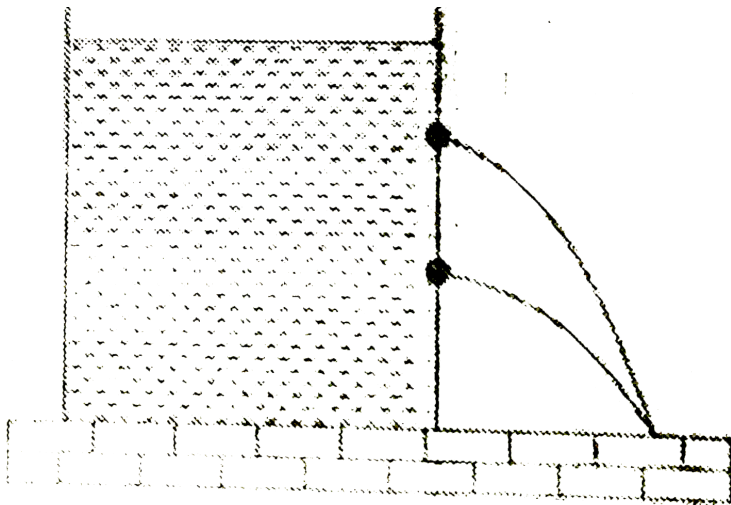

A.  $h_2 - h_1$

B.  $h_2 + h_1$

C.  $\frac{h_2 - h_1}{2}$

D.  $\frac{h_2 + h_1}{2}$

**Answer: D**



**Watch Video Solution**

**66.** A cylindrical vessel contains a liquid of density  $\rho$  up to height  $h$ . The liquid is closed by a piston of mass  $m$  and area of cross section  $A$ . There is a small hole at the bottom of the vessel. The speed  $v$  with which the liquid comes out of

the hole is

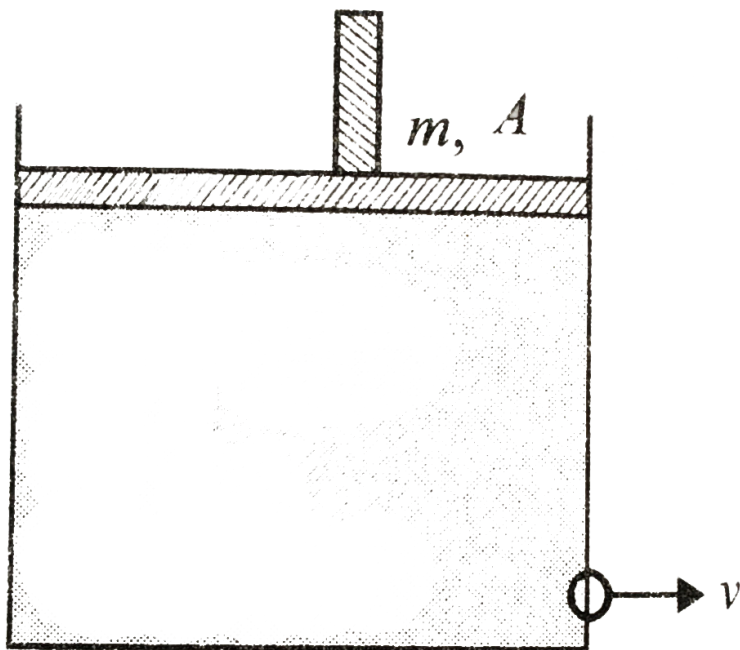

A.  $\sqrt{2gh}$

B.  $\sqrt{2\left(gh + \frac{mg}{\rho A}\right)}$

C.  $\sqrt{2\left(gh + \frac{mg}{A}\right)}$

D.  $\sqrt{2gh + \frac{mg}{A}}$

**Answer: B**



Watch Video Solution

67. The mean density of sea water is  $\rho$ , and bulk modulus is

B. The change in density of sea water in going from the surface of water to a depth of  $h$  is

A.  $\frac{B\rho^2}{gh}$

B.  $B\rho gh$

C.  $\frac{\rho^2 gh}{B}$

D.  $\frac{\rho gh}{B}$

Answer: C



Watch Video Solution

68. A block is fully submerged in a vessel filled with water by a spring attached to the bottom of the vessel. In equilibrium position spring is compressed. If the vessel now moves downwards with an acceleration  $a (< g)$ . What happens to the length of the spring.?

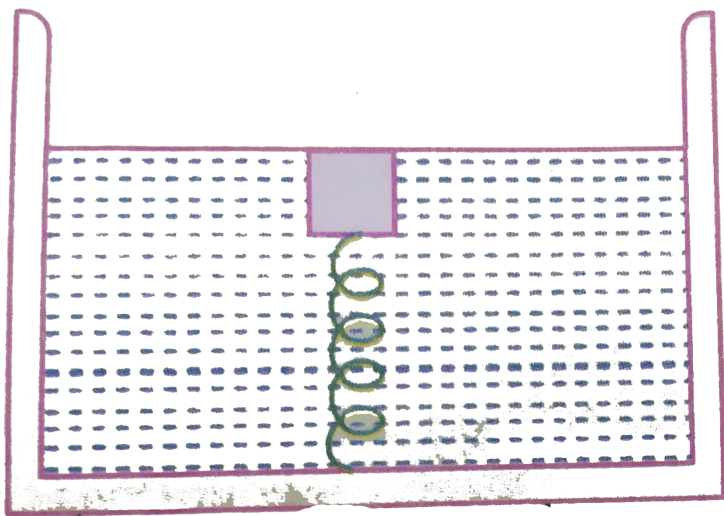

- A. will become zero
- B. may increase, decrease or remain constant
- C. will decrease

D. will increase

**Answer: D**



**Watch Video Solution**

**69.** A block of volume  $V$  and density  $\sigma_b$  is placed in liquid of density  $\sigma_l$  ( $\sigma_l > \sigma_b$ ), then block is moved upward upto a height  $h$  and it is still in liquid. The increase in gravitational energy of the block is :

A.  $\sigma_b Vgh$

B.  $(\sigma_b + \sigma_l)Vgh$

C.  $(\sigma_b - \sigma_l)Vgh$

D. None of these

Answer: A

 Watch Video Solution

70. Consider the situation shown in figure. The force  $F$  is equal to  $mg$ . If area of cross-section of the string is  $A$  and its Young's modulus is  $Y$ , the strain developed in the wire is (the string is light and there is no friction anywhere)

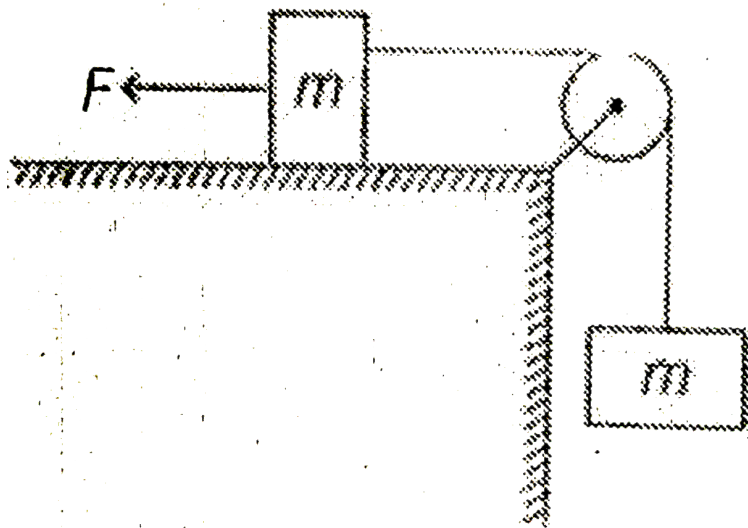



A.  $\frac{mg}{AY}$

B.  $\frac{2mg}{AY}$

C.  $\frac{mg}{2AY}$

D.  $\frac{3mg}{2AY}$

**Answer: A**



**Watch Video Solution**

**71.** Water pours out at the rate of  $Q$  from a tap, into a cylindrical vessel of radius  $r$ . Find the rate at which the height of water level rises when the height is  $h$ .

A.  $\frac{Q}{\pi r^2 h}$

B.  $\frac{Q}{\pi r^2}$

C.  $\frac{Q}{2\pi r^2}$

D.  $\frac{Q}{\pi r^2 h}$

**Answer: B**



**Watch Video Solution**

**72.** A thin rod of length 3 m is being rotated with 10 rad/sec about its one end. The change in length of the rod due to rotation is (Given : Young's modulus of elasticity of the wire,

$Y = 3 \times 10^8$  SI unit, density of the rod is  $10^4$  Unit)

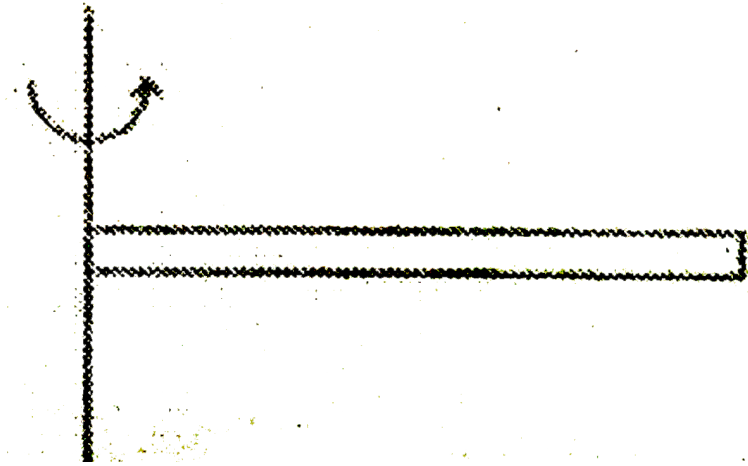

A. 2 cm

B. 4.5 cm

C. 1 cm

D. None of these

**Answer: D**



**Watch Video Solution**

73. Two narrow bores of diameters 3.0 mm and 6.0 mm are joined together to form a U-tube open at both ends. If the U-tube contains water, what is the difference in its levels in the two limbs of the tube? Surface tension of water at the temperature of the experiment is  $7.3 \times 10^{-2} \text{Nm}^{-1}$ . Take the angle of contact to be zero and density of water to be  $1.0 \times 10^3 \text{kgm}^{-3}$  ( $g = 9.8 \text{ms}^{-2}$ )

A. 5 mm

B. 10 mm

C. 15 mm

D. 20 mm

**Answer: A**



**Watch Video Solution**

74. A block of wood is floating in water such that  $1/2$  of it is submerged in water when the same block is floated in alcohol,  $1/3^{\text{rd}}$  of its volume is submerged. Now a mixture of water and alcohol is made taking equal volume of both and block is floated in it. What is the % of its volume that is now submerged?

A. 50

B. 40

C. 25

D. 60

**Answer: B**



**Watch Video Solution**

75. The area of cross-section of the two vertical arms of a hydraulic press are  $1\text{ cm}^2$  and  $10\text{ cm}^2$  respectively. A force of  $10\text{ N}$  applied. As shown in the figure, to a tight fitting light piston in the thinner arm balances a force  $F$  applied to the corresponding piston in the thicker arm. Assuming that the levels of water in both the arms are the same, we can conclude:-

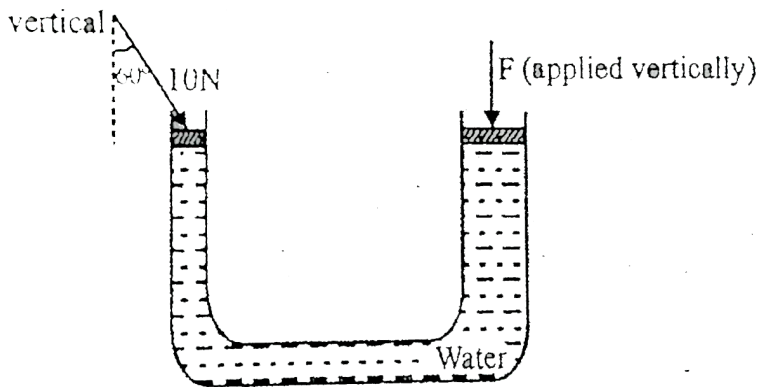

A.  $F = 100\text{ N}$

B.  $F = 50\text{ N}$

C.  $F = 25$

D.  $F$  cannot balance the effect of the force on the thinner piston

**Answer: B**

 [Watch Video Solution](#)

**76.** The end of a capillary tube is immersed into a liquid. Liquid slowly rises in the tube up to some height. The capillary-fluid system

A. will absorb heat

B. will release heat

C. will not be involved in any heat transfer

D. nothing can be said

**Answer: B**



**Watch Video Solution**

77. A block with base dimension  $25\text{cm} \times 50\text{cm}$  and weighing 25 kgf slides down a  $30^\circ$  inclined surface with a uniform speed of  $2\text{m}/\text{sec}$  on a 2mm thin oil film. The viscosity of oil



in SI units is

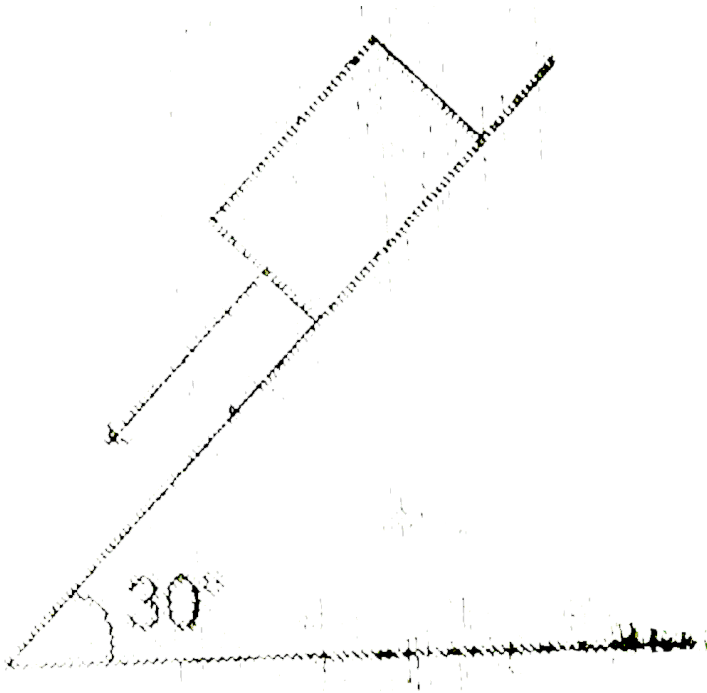

A.  $0.25 \text{ kgf sec} / \text{m}^2$

B.  $0.1 \text{ kgf sec} / \text{m}^2$

C.  $0.08 \text{ kgf sec} / \text{m}^2$

D.  $0.5 \text{ kgf sec} / \text{m}^2$

**Answer: B**



78. A wire frame ABCD has a soap film. The wire BC can slide on the frame without friction and it is in equilibrium in the position shown in the figure. Find  $m$ , if  $T$  is the surface tension of the liquid.

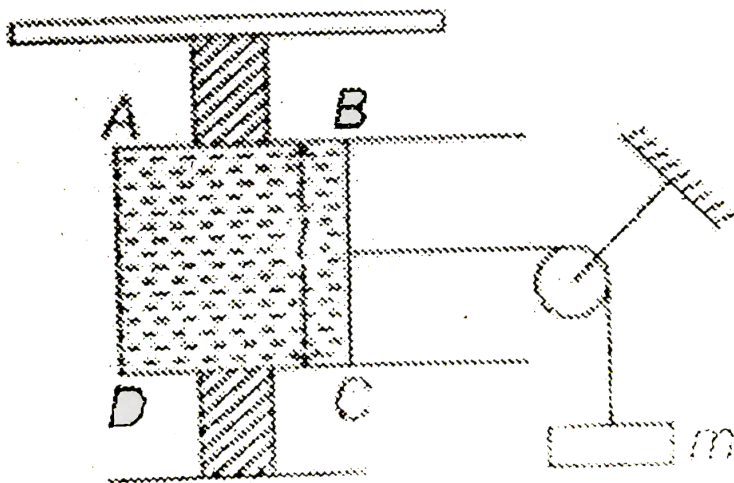

A.  $\frac{2Tl}{g}$

B.  $\frac{Tl}{g}$

C.  $\frac{Tl^2}{2g}$

D.  $\frac{Tl}{2g}$

**Answer: A**



**Watch Video Solution**

**79.** A liquid is filled in a spherical container of radius  $R$  up to a height  $h$ . At this position the liquid surface at the end is

also horizontal. The contact angle is

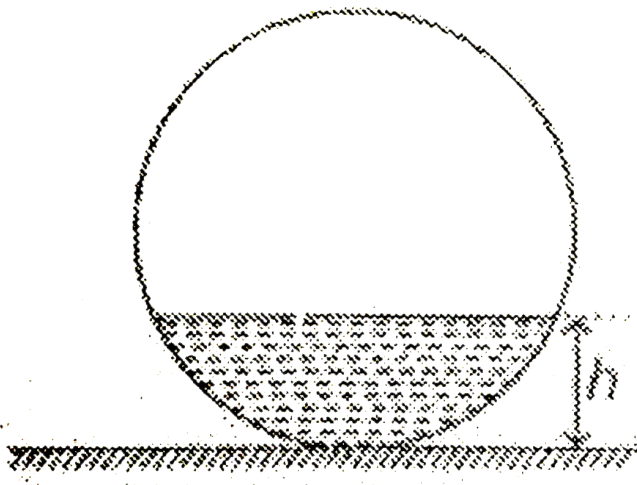

A. 0

B.  $\cos^{-1}\left(\frac{R-h}{R}\right)$

C.  $\cos^{-1}\left(\frac{h}{R}\right)$

D.  $\sin^{-1}\left(\frac{R-h}{R}\right)$

**Answer: B**



**Watch Video Solution**

80. Figure here shows the vertical cross-section of a vessel filled with a liquid of density  $\rho$ . The normal thrust per unit area on the walls vessel at point  $P$ , as shown, will be

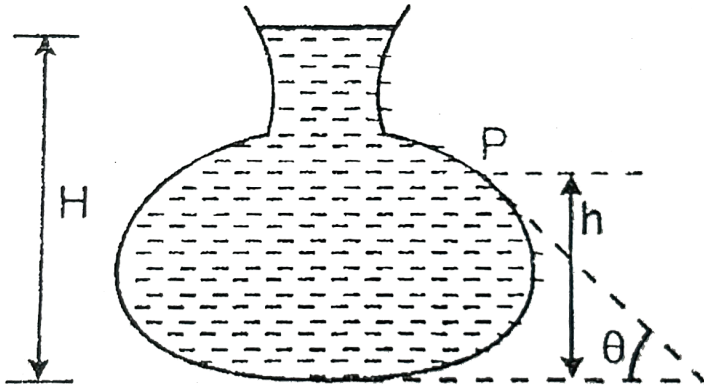

- A.  $h\rho g$
- B.  $H\rho g$
- C.  $(H - h)\rho g$
- D.  $(H - h)\rho g \cos \theta$

**Answer: C**



Watch Video Solution

**81.** A light semi cylindrical gate of radius  $R$  is pivoted at its mid point  $O$ , of radius  $R$  as shown in the figure holding liquid of density  $\rho$ . The force  $F$  required to prevent the

rotation of the gate is equal to

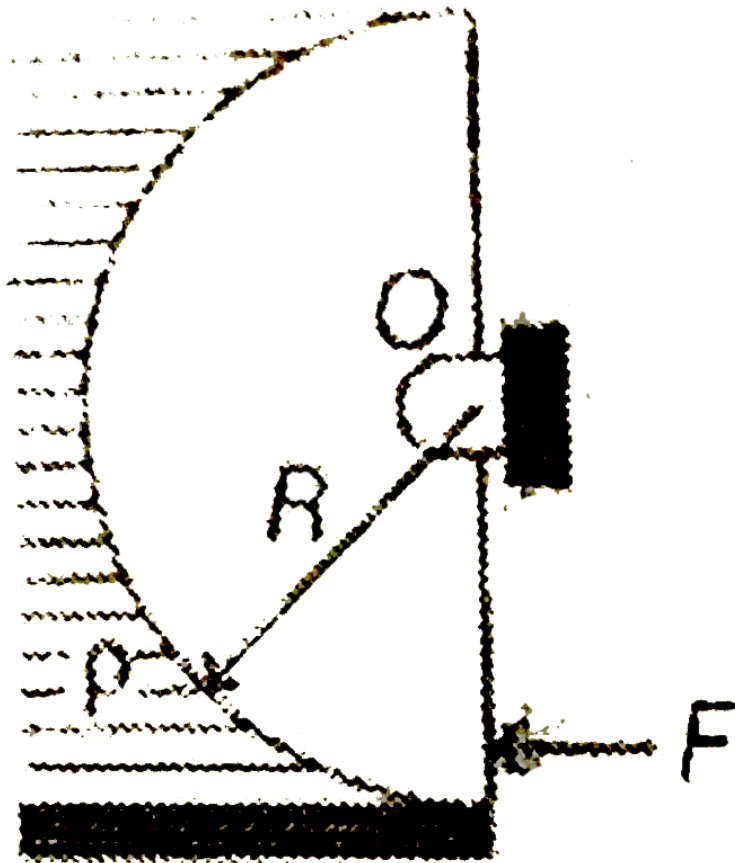

A.  $2\pi R^3 \rho g$

B.  $2\rho g R^3$

C.  $\frac{2R^2 \rho g}{3}$

D. None of these

**Answer: D**



**Watch Video Solution**

**Jee Advanced**

1. An ice cube of size  $a = 10\text{cm}$  is floating in a tank (base area  $A = 50\text{cm} \times 50\text{cm}$ ) partially filled with water. The change in gravitational potential energy, when ice melts completely is (density of ice is  $900\text{kg}/\text{m}^3$ )

A.  $-0.072\text{J}$

B.  $-0.24\text{J}$



C.  $-0.016J$

D.  $-0.045J$

**Answer: D**

 [Watch Video Solution](#)

2. A ball floats on the surface of water in a container exposed to the atmosphere. Volume  $V_1$  of its volume is inside the water. The container is now covered and the air is pumped out. Now let  $V_2$  be the volume immersed in water.

Then

A.  $V_1 = V_2$

B.  $V_1 > V_2$

C.  $V_2 > V_1$

D.  $V_2 = 0$

**Answer: C**

 [Watch Video Solution](#)

3. Two cylinders of same cross-section and length  $L$  but made of two different materials of densities  $d_1$  and  $d_2$  are cemented together to form a cylinder of length  $2L$ . The combination floats in a liquid of density  $d$   $d_1 < d_2$  then

A.  $d_1 < \frac{3}{4}d$

B.  $\frac{d}{2} > d_1$

C.  $\frac{d}{4} > d_1$

D.  $d < d_1$

**Answer: A**



**Watch Video Solution**

4. A cylinder of mass  $M$  and density  $d_1$  hanging from a string, is lowered into a vessel of cross-sectional area  $A$ , containing a liquid of density  $d_2$  ( $d_2 < d_1$ ) until it is fully immersed. The increase in pressure at the bottom of the vessel is

A.  $\frac{m\rho g}{\sigma s}$

B.  $\frac{mg}{s}$

C.  $\frac{m\sigma g}{\rho s}$

D. zero

**Answer: C**



**Watch Video Solution**

5. A ball of mass  $m$  and density  $\rho$  is immersed in a liquid of density  $3\rho$  at a depth  $h$  and released. To what height will the ball jump up above the surface of liquid ? (neglect the resistance of water and air).

A.  $h$

B.  $h/2$

C.  $2h$

D.  $3h$

**Answer: C**



**Watch Video Solution**

6. A block of mass  $M$  is suspended from a wire of length  $L$ , area of cross-section  $A$  and Young's modulus  $Y$ . The elastic potential energy stored in the wire is

A.  $\frac{1}{2} \frac{M^2 g^2 L}{AY}$

B.  $\frac{1}{2} \frac{Mg}{ALY}$

C.  $\frac{1}{2} \frac{M^2 g^2 A}{YL}$

D.  $\frac{1}{2} \frac{MgY}{AL}$

**Answer: A**



**Watch Video Solution**

7. A balloon with mass  $m$  is descending down with an acceleration  $a$  (*where*  $a < g$ ). How much mass should be removed from it so that it starts moving up with an acceleration  $a$ ?

A.  $\frac{2M(g)}{a}$

B.  $\frac{M(g + a)}{g}$

C.  $\frac{Mg}{g + a}$

D.  $\frac{2Ma}{g + a}$

**Answer: D**



**Watch Video Solution**

8. A solid ball of density  $\rho_1$  and radius  $r$  falls vertically through a liquid of density  $\rho_2$ . Assume that the viscous force acting on the ball is  $F = krv$ , where  $k$  is a constant and  $v$  its velocity. What is the terminal velocity of the ball ?

A.  $\left( 4\pi gr^2 \frac{\rho_1 - \rho_2}{3k} \right)$

B.  $\left( 2\pi r \frac{\rho_1 - \rho_2}{2gk} \right)$

C.  $\left( 2\pi \frac{g(\rho_1 + \rho_2)}{3gr^2k} \right)$

D. None of these

**Answer: A**



**Watch Video Solution**

9. A small steel ball falls through a syrup at a constant speed of  $10\text{cm s}^{-1}$ . If the steel ball is pulled upwards with a force equal to twice its effective weight, how fast will it move upwards?

A.  $10\text{cm s}^{-1}$

B.  $20\text{cm s}^{-1}$

C.  $5\text{cm s}^{-1}$

D. zero

**Answer: A**



**Watch Video Solution**



10. There is a horizontal film of soap solution. On it a thread is placed in the form of a loop. The film is pierced inside the loop and the thread becomes a circular loop of radius  $R$ . If the surface tension of the loop be  $T$ , then what will be the tension in the thread?

A.  $\pi R^2 T$

B.  $2RT$

C.  $RT$

D.  $\frac{\pi R^2}{T}$

**Answer: B**



**Watch Video Solution**

11. A drop of water of mass  $m$  and density  $\rho$  is placed between two well cleaned glass plates, the distance between which is  $d$ . What is the force of attraction between the plates?

( $T$  = surface tension)

A.  $\frac{Tm}{2\rho d^2}$

B.  $\frac{4Tm}{\rho d^2}$

C.  $\frac{2Tm}{\rho d^2}$

D.  $\frac{Tm}{\rho d^2}$

**Answer: C**



**Watch Video Solution**

12. What is the height to which a liquid rises between two long parallel plates, a distance  $d$  apart ? (Surface tension of liquid is  $T$  and density is  $\rho$ )

A.  $\frac{4T}{\rho g d}$

B.  $\frac{2T}{\rho g d}$

C.  $\frac{T}{\rho g d}$

D.  $\frac{T}{2\rho g d}$

**Answer: B**



**Watch Video Solution**

13. A small block of wood of specific gravity 0.5 is submerged at a depth of 1.2 m in a vessel filled with water. The vessel is

accelerated upwards with an acceleration  $a_0 = \frac{g}{2}$ . Time taken by the block to reach the surface, if it is released with zero initial velocity is ( $g = 10\text{m} / \text{s}^2$ )

A. 0.6 s

B. 0.4 s

C. 1.2 s

D. 1 s

**Answer: B**



**Watch Video Solution**

**14.** A uniform rod of length 2.0 m specific gravity 0.5 and mass 2 kg is hinged at one end to the bottom of a tank of water (specific gravity = 10) filled upto a height of 1.0 m as

shown in figure. Taking the case  $\theta = - 0^\circ$  the force exerted by the hinges on the rod is ( $g = 10\text{m} / \text{s}^2$ )

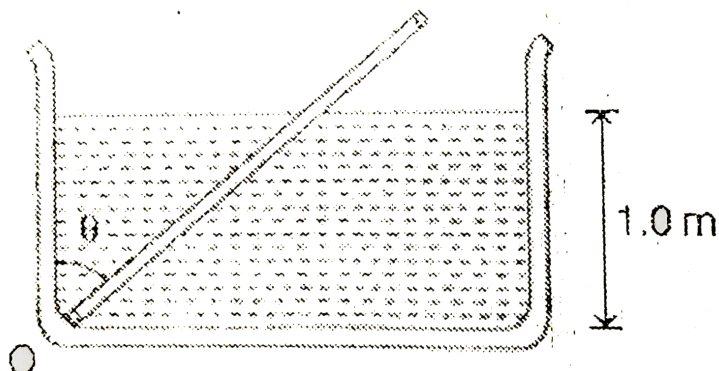

- A. 10.2 N upwards
- B. 4.2 N downwards
- C. 8.3 N downwards
- D. 6.2 N upwards

**Answer: C**

 [Watch Video Solution](#)

15. A cubical block of wood of edge  $a$  and density  $\rho$  floats in water of density  $2\rho$ . The lower surface of the cube just touches the free end of a mass less spring of force constant  $K$  fixed at the bottom of the vessel. The weight  $W$  put over the block so that it is completely immersed in water without wetting the weight is

A.  $a(a^2\rho g + k)$

B.  $a(a\rho g + 2k)$

C.  $a\left(\frac{a\rho g}{2} + 2k\right)$

D.  $a\left(a^2\lambda g + \frac{k}{2}\right)$

**Answer: D**



**Watch Video Solution**

16. The opening near the bottom of the vessel shown in the figure has an area  $A$ . A disc is held against the opening keep the liquid from running out. Let  $F_1$  be the net forces on the disc applied by liquid and air in this case. Now the disc is moved away from the opening a short distance. The liquid comes out and strikes the disc in elastically. Let  $F_2$  be the force exerted by the liquid in this condition. The  $F_1 / F_2$  is

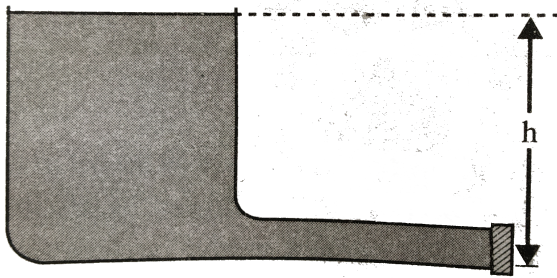

Fig. 4.183

A.  $\frac{1}{2}$

B. 1

C.  $\frac{2}{1}$

D.  $\frac{1}{4}$

**Answer: A**



**Watch Video Solution**

17. When at rest, a liquid stands at the same level in the tubes shown in figure. But as indicated a height difference  $h$  occurs when the system is given an acceleration  $a$  towards



the right. Here,  $h$  is equal to

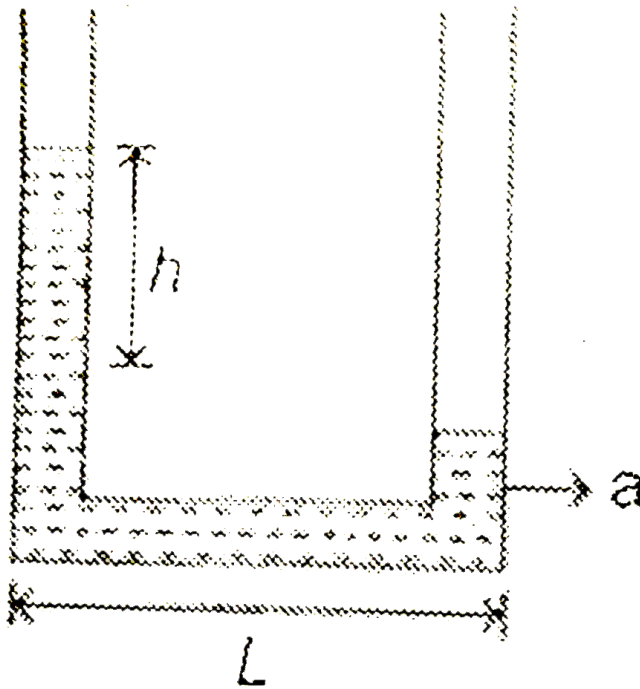

- A.  $\frac{aL}{2g}$
- B.  $\frac{gL}{2a}$
- C.  $\frac{gL}{a}$
- D.  $\frac{aL}{g}$

**Answer: D**

18. A glass tube  $80\text{cm}$  long and open ends is half immersed in mercury. Then the top of the tube is closed and it is taken out of the mercury. A column of mercury  $20\text{cm}$  long then remains in the tube. The atmospheric (in cm of Hg) is (assume temperature to be constant )

A. 75

B. 30

C. 60

D. 90

**Answer: C**

19. A small hole is made at the bottom of a symmetrical jar as shown in figure. A liquid is filled in to the jar up to a certain height. The rate of dissension of liquid is independent of level of the liquid in the jar. Then the surface of jar is a surface of revolution of curve

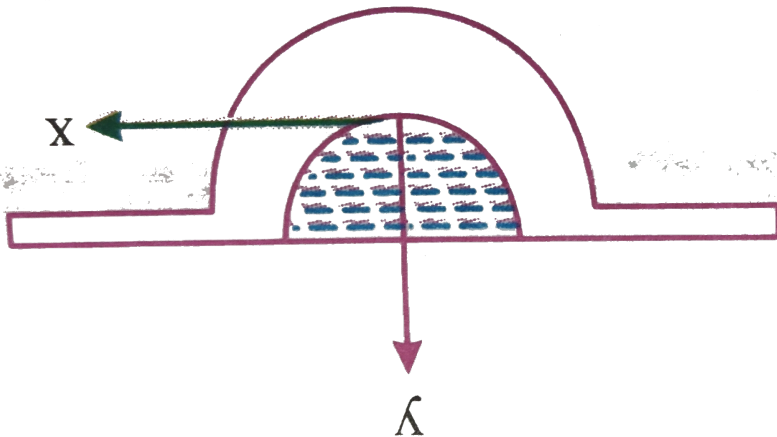

A.  $y = kx^4$

B.  $y = kx^2$

C.  $y = kx^3$

D.  $y = kx^5$

**Answer: A**



**Watch Video Solution**

**20.** There are two identical small holes of area of cross section  $a$  on the opposite sides of a tank containing liquid of density  $\rho$ . The differences in height between the holes is  $h$ . The tank is resting on a smooth horizontal surface. The horizontal force which will have to be applied on the tank to

keep it in equilibrium is

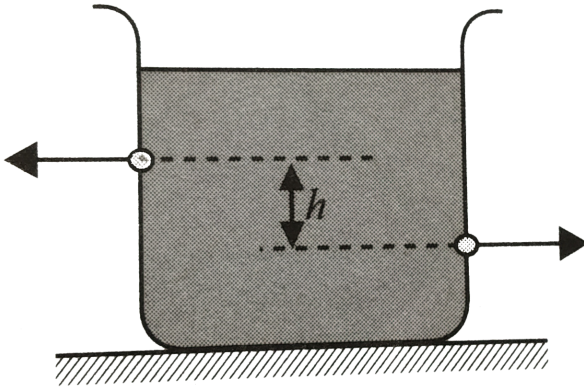

Fig. 4.184

- A.  $gh\rho$
- B.  $\frac{2gh}{\rho a}$
- C.  $2\rho agh$
- D.  $\frac{\rho gh}{a}$

**Answer: C**

 [Watch Video Solution](#)

21. Equal volume of two immiscible liquids of densities  $\rho$  and  $2\rho$  are filled in a vessel as shown in the figure. Two small holes are punched at depths  $h/2$  and  $3h/2$  from the surface of lighter liquid. If  $v_1$  and  $v_2$  are the velocities of efflux at these two holes, then  $v_1/v_2$  is

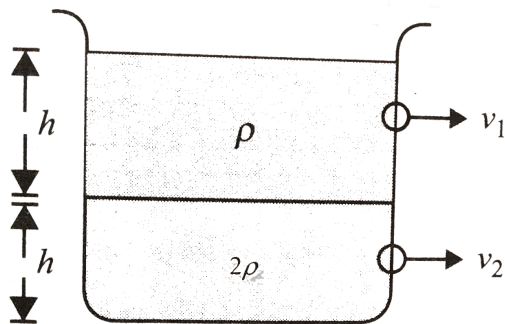

Fig. 4.

- A.  $\frac{1}{2\sqrt{2}}$
- B.  $\frac{1}{2}$
- C.  $\frac{1}{4}$
- D.  $\frac{1}{\sqrt{2}}$

**Answer: D**



**Watch Video Solution**

22. Two spheres of volume 250 cc each but of relative densities 0.8 and 1.2 are connected by a string and the combination is immersed in a liquid. Find the tension  $T$  in the string. ( $g = 10m / s^2$ )

A.  $5.0N$

B.  $0.5N$

C.  $1.0N$

D.  $2.0N$

**Answer: B**

23. A tube  $1\text{cm}^2$  in cross section is attached to the top of a vessel  $1\text{cm}$  high and of cross section  $100\text{cm}^2$ . Water is poured into the system filling it to a depth of  $100\text{cm}$  above the bottom of the vessel as shown in the figure. Take  $g = 10\text{ms}^{-2}$ . Find the correct statement.

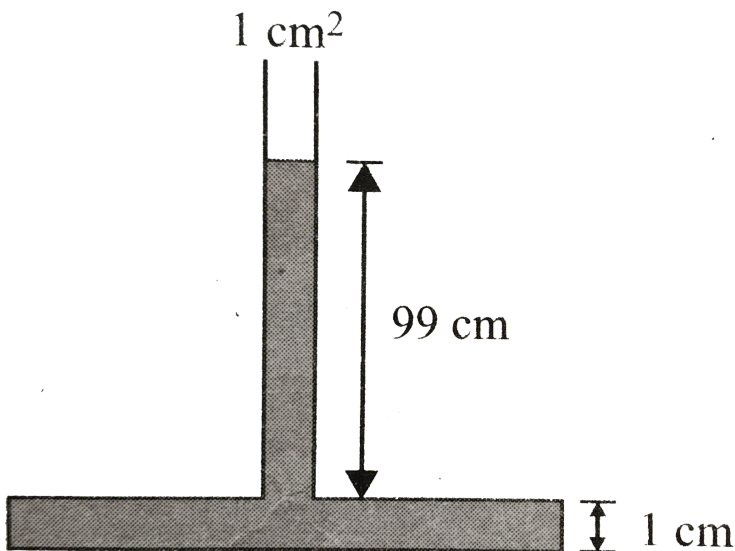

A. 1000 N



B. 990 N

C. 900 N

D. 100 N

**Answer: D**



**Watch Video Solution**

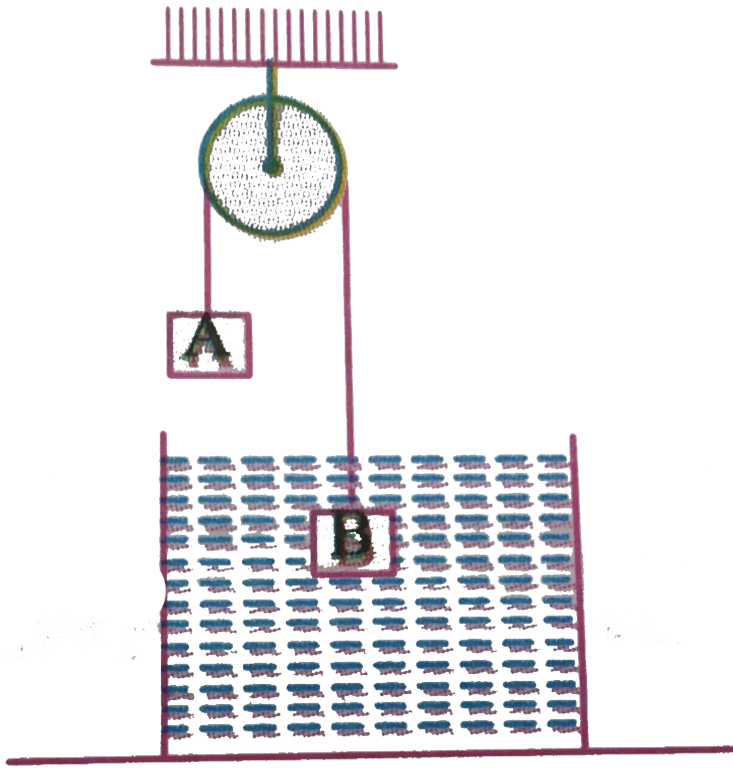

24.

In the arrangement shown in the figure  $\frac{m_A}{m_B} = \frac{2}{3}$  and the ratio of density of block B and the liquid is 2 : 1 The system is released from rest. Then

- A. block B will oscillate but not simple harmonically
- B. block B will oscillate simple harmonically

C. the system will remain in equilibrium

D. None of the above

**Answer: A**



**Watch Video Solution**

**25.** A uniform elastic plank moves due to a constant force  $F_0$  applied at one end whose area is  $S$ . The Young's modulus of the plank is  $Y$ . The strain produced in the direction of force is

A.  $\frac{F_0 Y}{S}$

B.  $\frac{F_0}{SY}$

C.  $\frac{F_0}{2SY}$

D.  $\frac{F_0 Y}{2S}$

**Answer: C**

 [Watch Video Solution](#)

26. if  $\rho$  is the density of the material of a wire and  $\sigma$  is the breaking stress. The greatest length of the wire that can hang freely without breaking is

A.  $\frac{2\sigma}{\rho g}$

B.  $\frac{\rho}{\sigma g}$

C.  $\frac{\rho g}{2\sigma}$

D.  $\frac{\sigma}{\rho g}$

**Answer: D**



Watch Video Solution

27. If the ratio of lengths, radii and Young's moduli of steel and brass wires in the figure are  $a$ ,  $b$  and  $c$  respectively then the corresponding ratio of increase in their lengths is

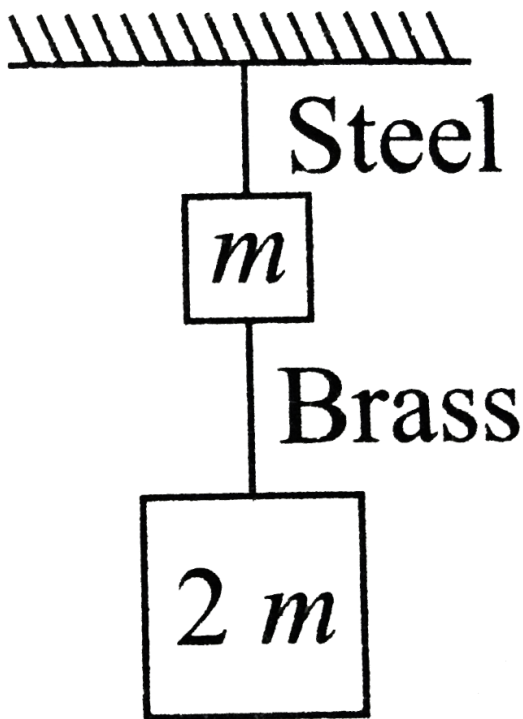

A.  $\frac{2a^2c}{b}$

B.  $\frac{3a}{2b^2c}$

C.  $\frac{2ac}{b^2}$

D.  $\frac{3c}{2ab^2}$

**Answer: B**



**Watch Video Solution**

**28.** A uniform rod of length  $L$ , has a mass per unit length  $\lambda$  and area of cross section  $A$ . The elongation in the rod is  $l$  due to its own weight, if it suspended from the ceiling of a room. The Young's modulus of the rod is

A.  $\frac{2\lambda gL^2}{Al}$

B.  $\frac{\lambda g L^2}{2Al}$

C.  $\frac{2\lambda g L}{Al}$

D.  $\frac{\lambda g l^2}{AL}$

**Answer: B**



**Watch Video Solution**

**29.** A vertical capillary is brought in contact with the water surface (surface tension =  $T$ ). The radius of the capillary is  $r$  and the contact angle  $\theta = 0^\circ$ . The increase in potential energy of the water (density =  $\rho$ ) is

A. independent of  $\rho$

B. independent of  $r$

C. independent of T

D. zero

**Answer: B**



**Watch Video Solution**

**30.** An empty container has a circular hole of radius  $r$  at its bottom. The container is pushed into water very slowly as shown. To what depth the lower surface of container (from surface of water) can be pushed into water such that water



does not flow into the container?

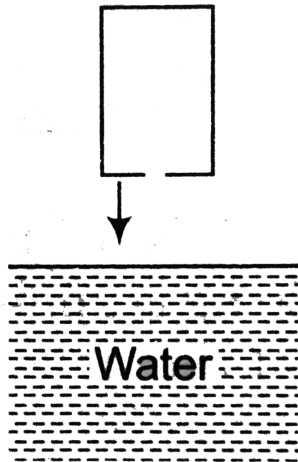

- A.  $\frac{4T}{\rho r g}$
- B.  $\frac{3T}{\rho r g}$
- C.  $\frac{2T}{\rho r g}$
- D.  $\frac{T}{\rho r g}$

**Answer: C**



**Watch Video Solution**

31. Water rises to a height  $h$  in a capillary tube lowered vertically into water to a depth  $l$  as shown in the figure. The lower end of the tube is now closed, the tube is taken out of the water and opened again. The length of the water column remaining in the tube will be

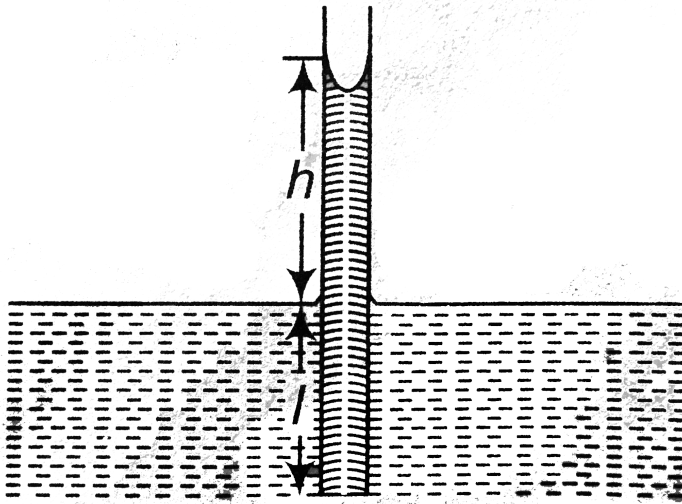

- A.  $l$
- B.  $l + h$
- C.  $h$

D. 2h

**Answer: D**



**Watch Video Solution**

**32.** A cylindrical vessel of area of cross-section  $A$  is filled with water to a height  $H$ . It has capillary tube of length  $l$  and radius  $r$  fitted horizontally at its bottom. If the coefficient of viscosity of water is  $\eta$ , then time required in which level will fall to a height  $\frac{H}{2}$  is (density of water is  $\rho$ )

A.  $\frac{\eta l r^2}{4A\rho} \ln(2)$

B.  $\frac{4\eta l r^4}{\pi g A \rho} \ln\left(\frac{1}{2}\right)$

C.  $\frac{8\eta l A}{\rho \pi g r^4} \ln(2)$

D.  $\frac{4H\eta l\rho}{\pi gr^4} \ln(2)$

**Answer: C**

 [Watch Video Solution](#)

**33.** One end of a glass capillary tube with a radius  $r = 0.05\text{cm}$  is immersed into water to a depth of  $h = 2\text{cm}$ . Excess pressure required to blow an air bubble out of the lower end of the tube will be ( $S. T$  of water =  $70\text{dyne/cm}$ ). Take  $g = 980\text{cm/s}^2$ .

A.  $480\text{N/m}^2$

B.  $680\text{N/m}^2$

C.  $20003\text{N/m}^2$

D.  $820N/m^2$

**Answer: C**



**Watch Video Solution**

**34.** The range of water flowing out of a small hole made at a depth  $10m$  below water surface in a large tank is  $R$ . Find the extra pressure (in atm) applied on the water surface so that

range becomes  $2R$ . Take  $1\text{ atm} = 10^5\text{ Pa}$ .

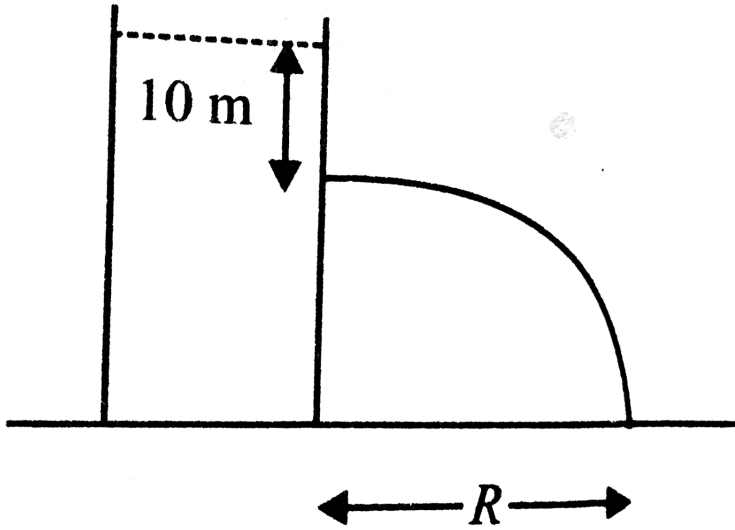

- A. 9 atm
- B. 4 atm
- C. 5 atm
- D. 3 atm

**Answer: D**



**Watch Video Solution**

35. What force must be applied to detach two wetted photographic plates ( $9\text{cm} \times 12\text{cm}$ ) in size from each other without shifting them. The thickness of water between the plates is 0.05 mm. Surface tension of water is 0.073 N/m.

A.  $31.5\text{N}$

B.  $16.5\text{N}$

C.  $40.5\text{N}$

D.  $20.0\text{N}$

**Answer: A**



**Watch Video Solution**

36. A cylinder with a movable piston contains air under a pressure  $p_1$  and a soap bubble of radius 'r'. The pressure  $p_2$  to which the air should be compressed by slowly pushing the piston into the cylinder for the soap bubble to reduce its size by half will be (The surface tension is  $\sigma$  and the temperature T is maintained constant).

A.  $p_1 + \frac{4T}{r}$

B.  $4p_1 + \frac{12T}{r}$

C.  $8p_1 + \frac{24\sigma}{r}$

D.  $p_1 + \frac{2T}{r}$

**Answer: C**



**Watch Video Solution**



37. A vertically jet of water coming out of a nozzle with velocity  $20\text{ m/s}$  supports a plate of mass  $M$  stationary at a height  $h = 15\text{ m}$ , as shown in the figure. If the rate of water flow is 1 litre per second, the mass of the plate is (Assume the collision to be perfectly inelastic).

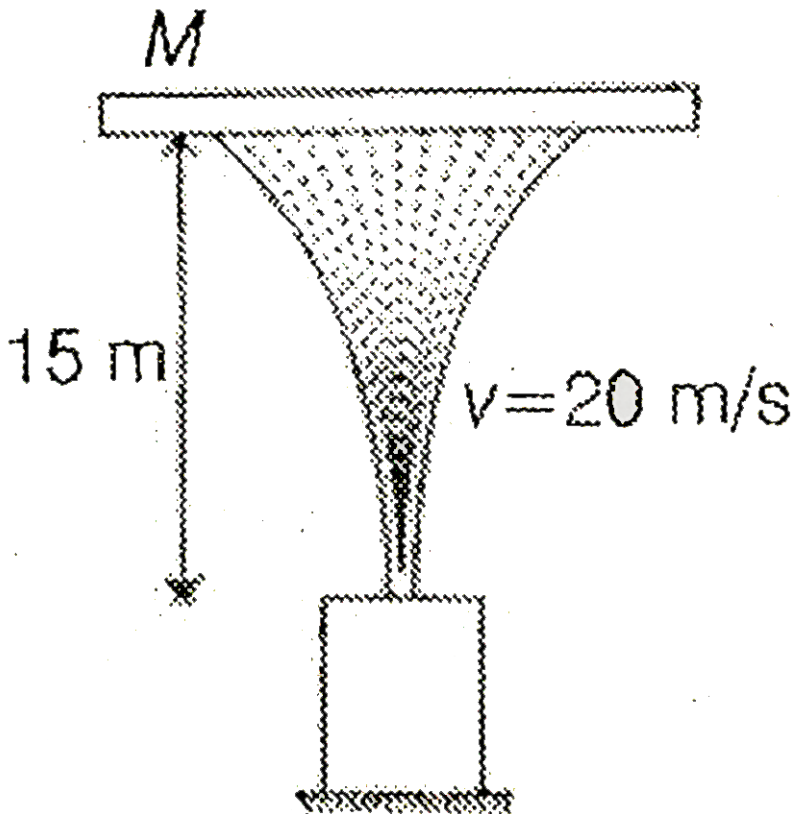

A. 1kg

B.  $\sqrt{2}kg$

C. 2kg

D. 4kg

**Answer: A**



**Watch Video Solution**

**38.** A uniform rod  $OB$  of length  $1m$ , cross-sectional area  $0.012m^2$  and relative density  $2.0$  is free to rotate about smooth hinge  $O$  in vertical plane. The rod is held with a horizontal string  $AB$  which can withstand a maximum tension of  $45N$ . The rod and string system is kept in water as shown in figure. The maximum value of angle  $\alpha$  which the

rod can make with vertical without breaking the string is

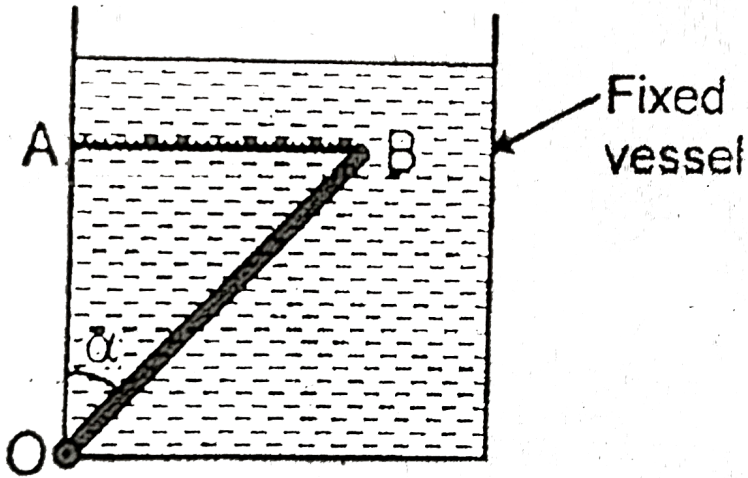

A.  $45^\circ$

B.  $37^\circ$

C.  $53^\circ$

D.  $60^\circ$

**Answer: B**



**Watch Video Solution**

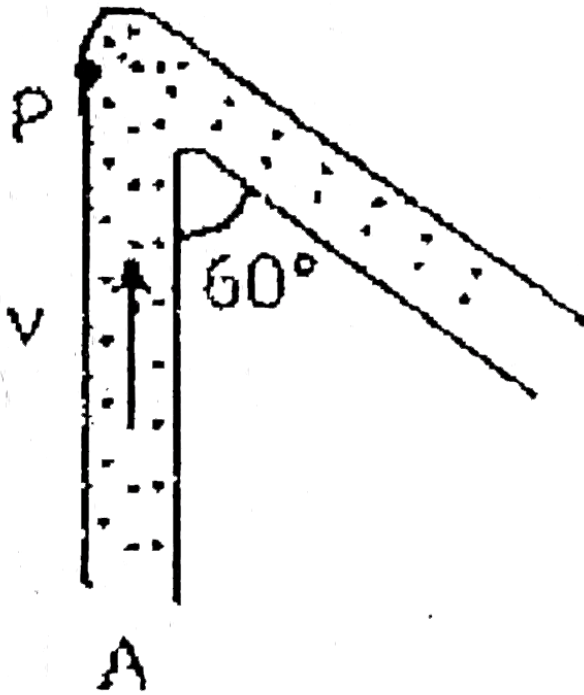

39.

Water (density  $\rho$ ) is flowing through the uniform tube of cross-sectional area  $A$  with a constant speed  $v$  as shown in the figure. Find the magnitude of force exerted by the water on the curved corner of the tube is (neglect viscous forces)

A.  $\sqrt{3}\rho Av^2$

B.  $\rho Av^2$

C.  $\sqrt{2}\rho Av^2$

D.  $\frac{\rho Av^2}{\sqrt{2}}$

**Answer: A**

 [Watch Video Solution](#)

**40.** A tube of fine bore  $AB$  is connected to a manometer  $M$  as shown. The stop cock  $S$  controls the flow of air.  $AB$  is dipped into a liquid whose surface tension is  $T$ . On opening the stop cock for a while, a bubble is formed at  $B$  and the manometer liquid and  $r$  the radius of curvature of the

bubble, then the surface tension  $T$  of the liquid is given by

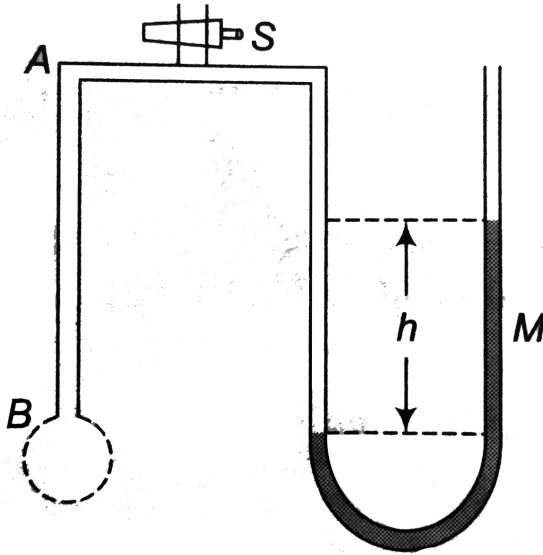

- A.  $\rho h r g$
- B.  $2\rho h g r$
- C.  $\frac{r h \rho g}{2}$
- D.  $\frac{r h \rho g}{4}$

Answer: D



Watch Video Solution

41. A bucket water filled upto a height = 15 cm. The bucket is tied to a rope which is passed over a frictionless light pulley and the other end of the rope is tied to a weight of mass which is half of that of the (bucket + water). The water pressure above atmospheric pressure at the bottom is

- A. 0.5 kPa
- B. 1 kPa
- C. 5kPa
- D. None of these

**Answer: B**



[Watch Video Solution](#)

42. An open cubical tank was initially fully filled with water. When the tank was accelerated on a horizontal plane along one of its side it was found that one third of volume of water was spilled out. The acceleration was

- A.  $g/3$
- B.  $2g/3$
- C.  $g/2$
- D.  $g/4$

**Answer: B**



**Watch Video Solution**



43. Some liquid is filled in a cylindrical vessel of radius  $R$ . Let  $F_1$  be the force applied by the liquid on the bottom of the cylinder. Now the same liquid is poured into a vessel of uniform square cross-section of side  $R$ . Let  $F_2$  be the force applied by the liquid on the bottom of this new vessel. (Neglect atmosphere pressure). Then

A.  $F_1 = \pi F_2$

B.  $F_1 = \frac{F_2}{\pi}$

C.  $F_1 = \sqrt{\pi} F_2$

D.  $F_1 = F_2$

**Answer: D**



**Watch Video Solution**

**44.** A glass capillary of length  $l$  and inside radius  $r$  ( $r \ll l$ ) is submerged vertically into water. The upper end of the capillary is sealed. The atmospheric pressure is  $p_0$ . To what length  $h$  has the capillary to be submerged to make the water levels inside and outside the capillary coincide. Assume that temperature of air in the capillary remains constant. (given, surface tension of water =  $T$ , angle of

contact between glass water interface =  $0^\circ$ )

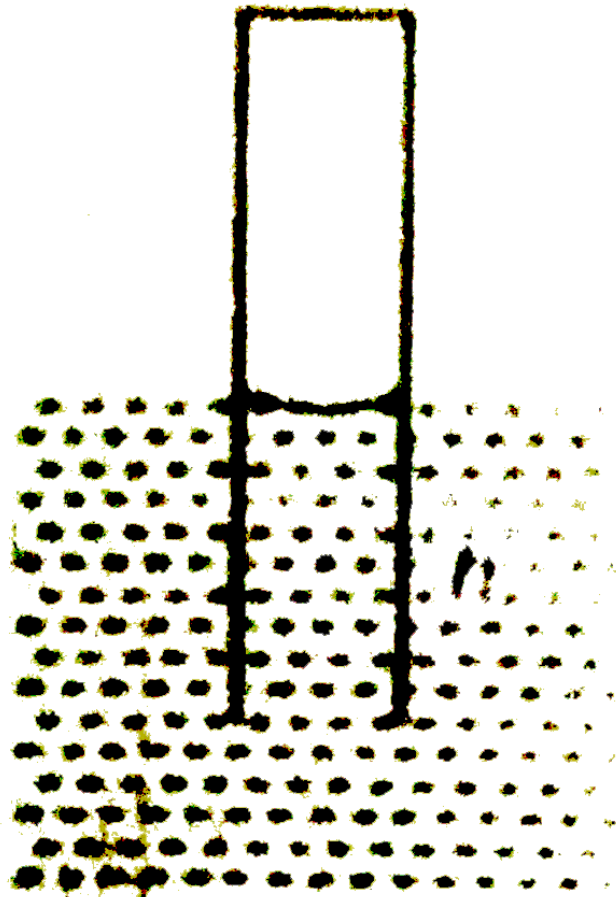

A.  $\frac{l}{1 + \frac{p_0 r}{T}}$

B.  $\frac{l}{1 + \frac{p_0 r}{2T}}$

C.  $\frac{l}{1 + \frac{p_0 r}{4T}}$

D.  $\frac{l}{1 + \frac{2p_0r}{T}}$

**Answer: B**

 [Watch Video Solution](#)

**45.** The pressure at the bottom of an open tank of water is  $3p$  where  $p$  is the atmospheric pressure. If the water is drawn out till the level of water remains one fifth, the pressure at the bottom of the tank will now be

A.  $2p$

B.  $(13/5)p$

C.  $(7/5)p$

D.  $(4/5)p$

Answer: B

 Watch Video Solution

46. Figure shows a siphon. Choose the wrong statement.

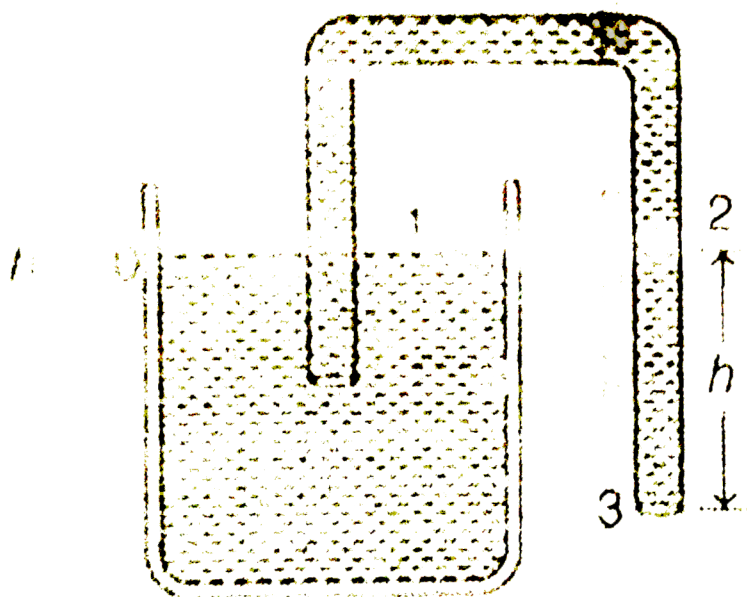

( $p_0$  = atmospheric pressure)

A. Siphon works when  $h > 0$

B. Pressure at point 2 inside the tube is  $p_2 = p_0 - \rho gh$

C. Pressure at point 3 is  $p_0$

D. None of the above

**Answer: D**

 [Watch Video Solution](#)

47. A U-tube of cross section  $A$  and  $2A$  contains liquid of density  $\rho$ . Initially, the liquid in the two arms are held with a level difference  $h$  as shown in figure. After being released the levels equalize after some time. The work done by

gravity forces on the liquid in the process is :

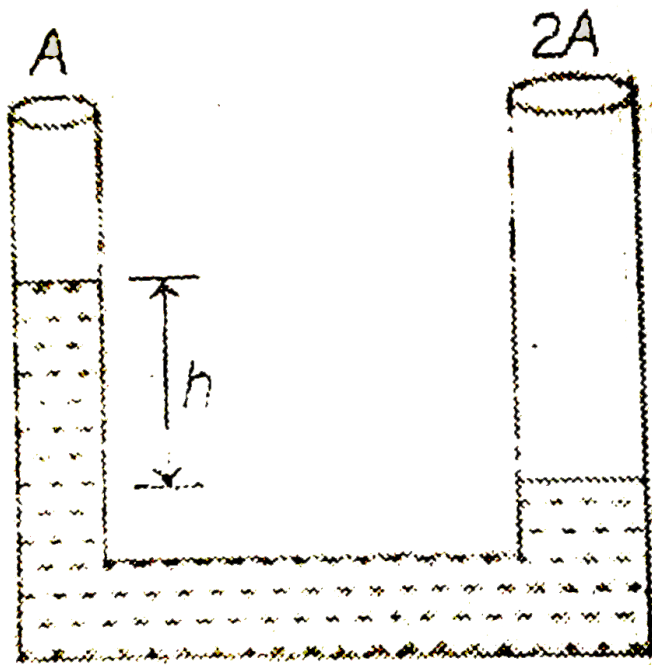

A.  $\frac{2}{3}\rho Agh^2$

B.  $\rho Agh^2 / 3$

C.  $\rho Agh^2 / 6$

D.  $\frac{3}{4}\rho Agh^2$

**Answer: B**



Watch Video Solution

48. A stream of liquid, set at an angle  $\theta$ , is directed against a plane surface (figure). The liquid, after hitting the surface, spreads over it. Find the pressure on the surface. The density of the liquid is  $\rho$  and its velocity is  $v$ .

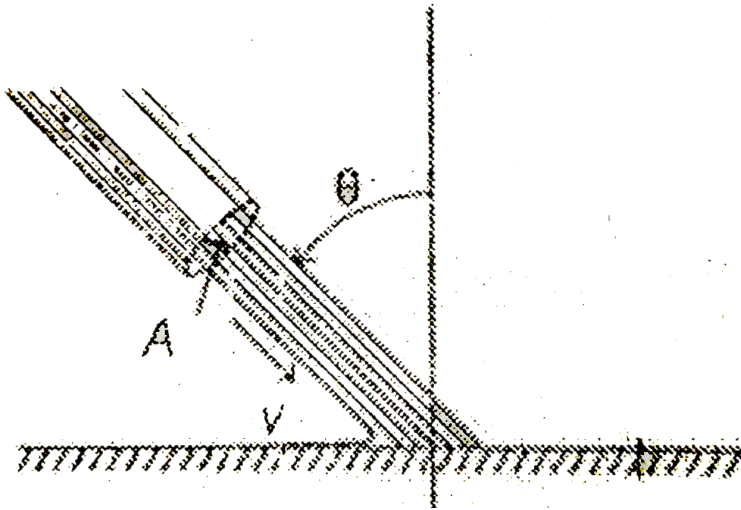

A.  $\rho v^2 \cos \theta$

B.  $\rho v^2 \cos^2 \theta$



C.  $\frac{1}{2}\rho v^2 \cos \theta$

D.  $\frac{1}{2}\rho v^2 \cos^2 \theta$

**Answer: A**



**Watch Video Solution**

**49.** A tube of small uniform cross section is used to siphon the water from the vessel. Then choose the correct alternative (s) :

$$(\rho_{\text{water}} = 10^3 \text{ kg/m}^3, g = 10 \text{ m/s}^2, P_{\text{atm}} = 10^5 \text{ Pa})$$

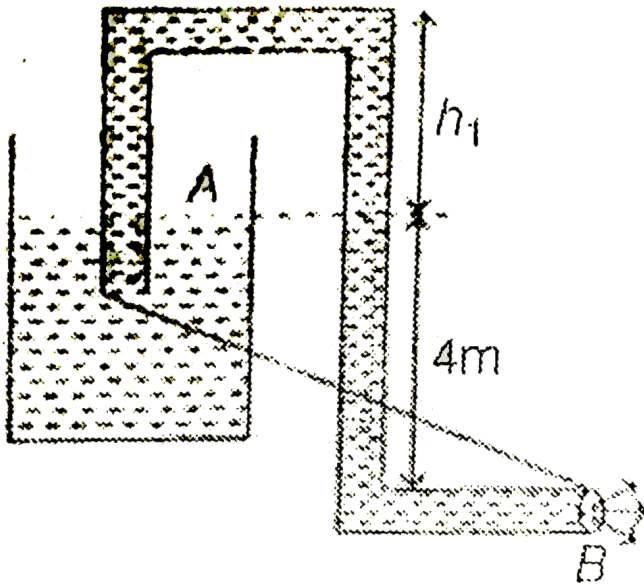

A. Water will come out from section B with a velocity of

$$\sqrt{80} \text{ m/s}$$

B. The greatest value of  $h_1$  for which the siphon will work

is 10 m.

C. both are correct

D. both are wrong

**Answer: A**



**Watch Video Solution**

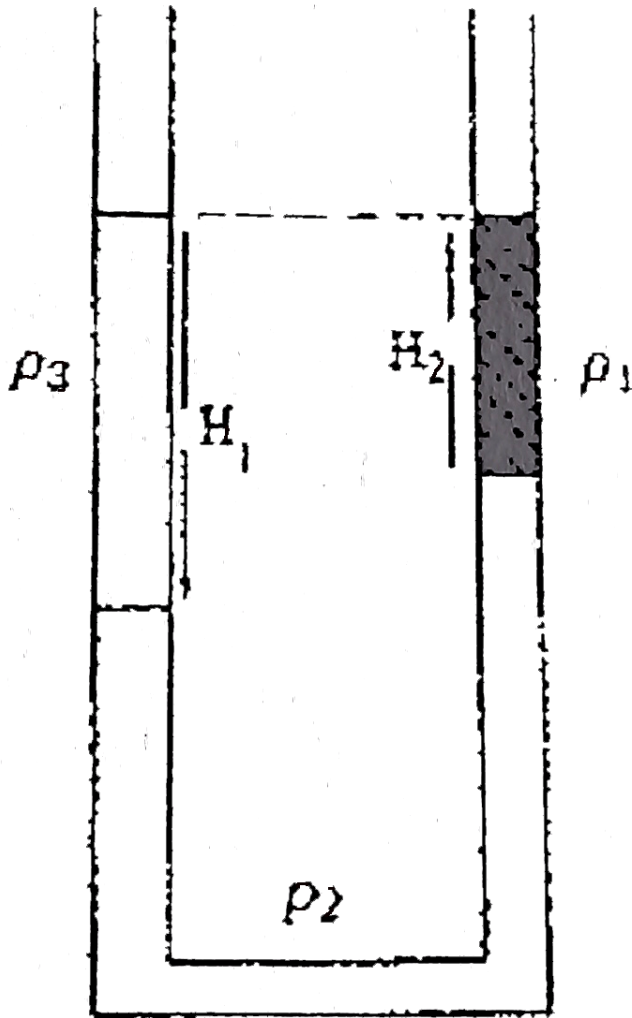

50.

There are three different liquids, with densities  $\rho_1$ ,  $\rho_2$  and  $\rho_3$  in a U-shaped container as shown in the picture the lengths shown are  $H_1 = 15\text{cm}$  and  $H_2 = 10\text{cm}$  which of

the following equations gives the correct relation between the densities of the fluids in the container?

A.  $3\rho_3 = 2\rho_1 + \rho_2$

B.  $\rho_3 = 2\rho_1 + 3\rho_2$

C.  $2\rho_3 = 3\rho_1 + \rho_2$

D.  $\rho_3 = 3\rho_1 + 2\rho_2$

**Answer: A**



**Watch Video Solution**

**51.** A solid sphere of radius  $r$  is floating at the interface of two immiscible liquids of densities  $\rho_1$  and  $\rho_2$  ( $\rho_2 > \rho_1$ ), half of its volume lying in each. The height of the upper liquid column from the interface of the two liquids is  $h$ . The force

exerted on the sphere by the upper liquid is (atmospheric pressure =  $p_0$  and acceleration due to gravity is  $g$ ):

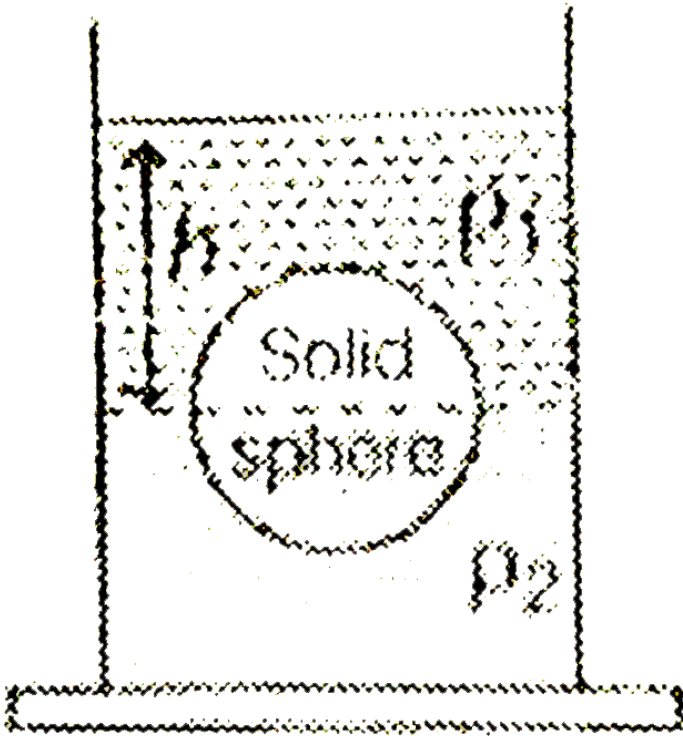

A.  $p_0\pi r^2 + \left(h - \frac{2}{3}r\right)\pi r^2\rho_1g$

B.  $\left(h - \frac{2}{3}r\right)\pi r^2\rho_1g$

C.  $\frac{2}{3}\pi r^2\rho_1g$

D.  $p_0 \times \pi r^2$

**Answer: A**



**Watch Video Solution**

**52.** A hollow sphere of volume  $V$  is floating on water surface with half immersed in it. What should be the minimum volume of water poured inside the sphere so that the sphere now sinks into the water ?

A.  $V/2$

B.  $V/3$

C.  $V/4$

D.  $V$

**Answer: A**

53. The diagram shows a tall cylindrical container kept on a horizontal surface. From a tap, water come with constant rate  $qm^3 / s$ . Initially the container was empty. An orifice of area of cross section  $A$  is made at some height  $h$  in the side wall of the container. If the horizontal range of the water jet in steady is found to be  $2h$ , then the relation between  $h$  and



q is

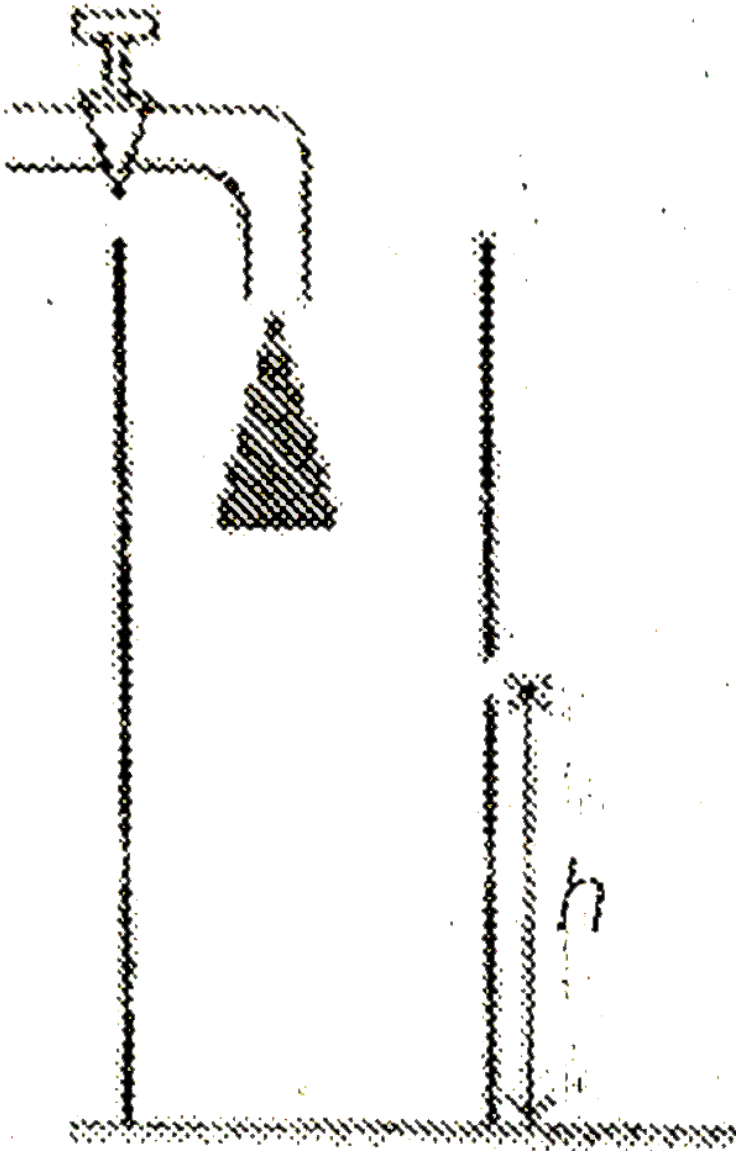

$$A \cdot h = \frac{q^2}{gA^2}$$

$$\text{B. } h = \frac{q^2}{2gA^2}$$

$$\text{C. } h = \frac{3q^2}{2gA^2}$$

$$\text{D. } h = \frac{2q^2}{gA^2}$$

**Answer: B**



**Watch Video Solution**

**54.** Air is blown through a pipe AB at a rate of 15 litres per minute. The cross sectional area of the broad portion of the pipe AB is  $2\text{cm}^2$  and that of the narrow portion is  $0.5\text{cm}^2$ .

The difference in water level  $h$  is ( $\rho_{\text{air}} = 1.32 \text{ kg/m}^3$ )

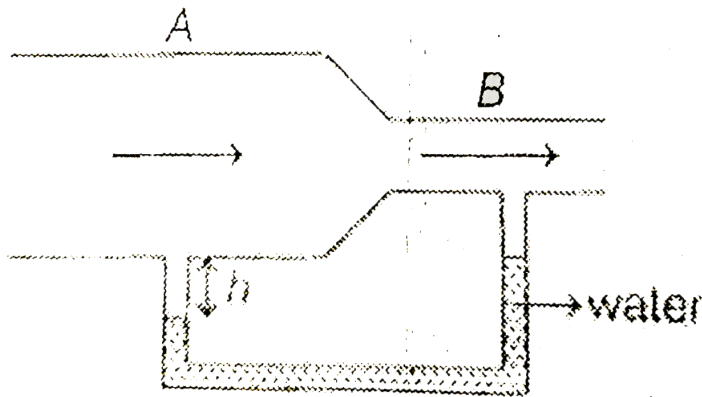

- A.  $5.26 \text{ mm}$
- B.  $1.54 \text{ mm}$
- C.  $4.38 \text{ mm}$
- D.  $3.26 \text{ mm}$

**Answer: B**

 [Watch Video Solution](#)

55. A tube of radius  $r$  and sufficient height is dipped in a liquid of surface tension  $S$  and density  $\rho$ . Heat developed upto steady state will be

Note:  $\theta$  is the contact angle

A.  $\frac{\pi S^2 \cos^2 \theta}{\rho g}$

B.  $\frac{\pi S^2 \cos^2 \theta}{2\rho g}$

C.  $\frac{2\pi S^2 \cos^2 \theta}{\rho g}$

D.  $\frac{4\pi S^2 \cos^2 \theta}{\rho g}$

**Answer: C**



**Watch Video Solution**

56. A hollow object of volume  $V$  is immersed in a tank. The object is tied to the bottom of the tank by two wires which make an angle  $30^\circ$  with the horizontal as shown in figure. The object would float if it was set free and one fourth volume is immersed in liquid of density  $\rho_0$ . The tension in the wires is

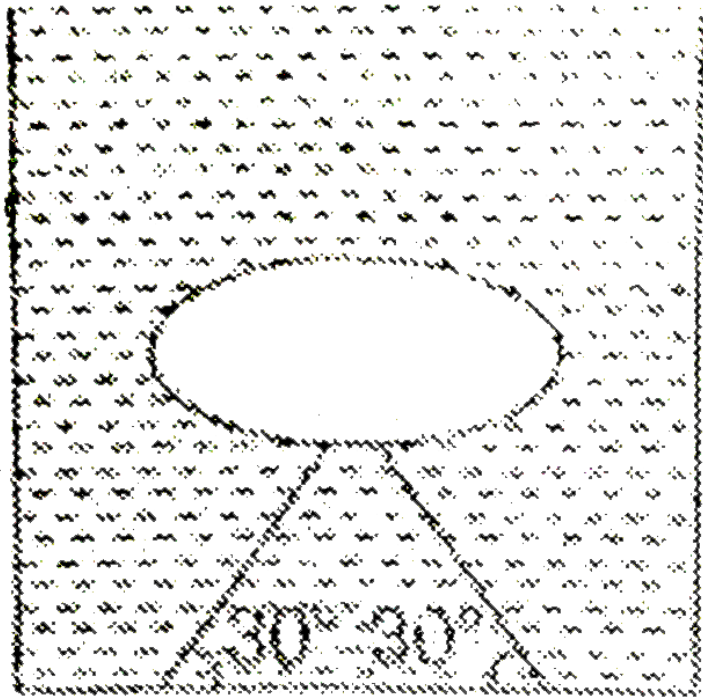

A.  $\frac{V\rho_0g}{4}$

B.  $\frac{3V\rho_0g}{4}$

C.  $\frac{5V\rho_0g}{4}$

D.  $V\rho_0g$

**Answer: B**

 [Watch Video Solution](#)

**57.** A bent tube of uniform cross section is mounted on a cart which is accelerating towards right with constant acceleration 'a'. The total length of the liquid is  $2\sqrt{2}l$ . Find the level difference between two limbs in equilibrium

$$(a = 2m/s^2, l = 10m)$$

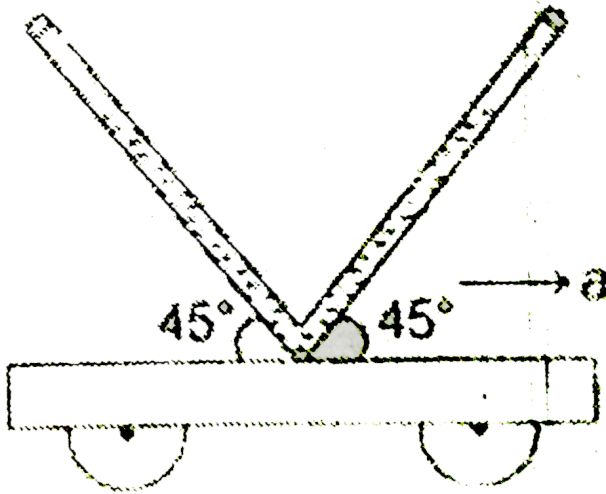

- A. 2 m
- B. 4 m
- C. 6 m
- D. 12 m

**Answer: B**



**Watch Video Solution**

## More Than One Option Is Correct

1. A metallic sphere weighs  $210g$  in air,  $180 g$  in water and  $120 g$  in an unknown liquid. Find the density of metal and of liquid.

A. metal is 3

B. metal is 7

C. liquid is 3

D. liquid is 7

**Answer: B::C**



**Watch Video Solution**



2. Water is being poured in a vessel at a constant rate  $\alpha m^2 / s$ . There is a small hole of area  $a$  at the bottom of the tank. The maximum level of water in the vessel is proportional to

A.  $\alpha$

B.  $\alpha^2$

C.  $a^{-1}$

D.  $a^{-2}$

**Answer: B::D**



**Watch Video Solution**

3. Equal volumes of a liquid are poured in the three vessels  $A$ ,  $B$  and  $C$  ( $h_1 < h_2 < h_3$ ). All the vessels have the same base area. Select the correct alternatives.

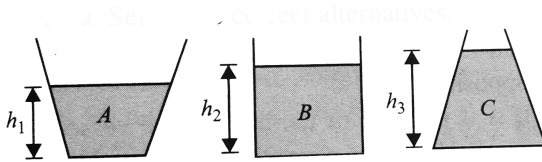

Fig. 4.228

© 2010 Pearson Education, Inc. All rights reserved.

- A. The force on the base will be maximum in vessel A
- B. The force on the base will be maximum in vessel C
- C. Net force exerted by liquid in all the three vessels is equal
- D. Net force exerted by liquid in vessel A is maximum

**Answer: B::C**



**Watch Video Solution**

4. A tank is filled upto a height  $h$  with a liquid and is placed on a platform of height  $h$  from the ground. To get maximum range  $x_m$  a small hole is punched at a distance of  $y$  from the free surface of the liquid. Then

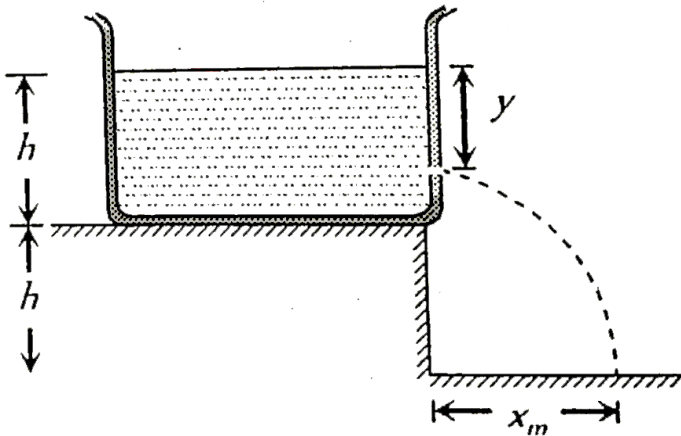

A.  $x_m = 2h$

B.  $x_m = 1.5h$

C.  $y = h$

$$D. y = 0.75h$$

**Answer: A::C**

 [Watch Video Solution](#)

5. A small solid ball of density  $\rho$  is held inside at point A of a cubical container of side L, filled with an ideal liquid of density  $4\rho$  as shown in the figure. Now, if the container starts moving with constant acceleration  $a$  horizontally and the ball is released from point A simultaneously, then

choose from following the correct option(s)

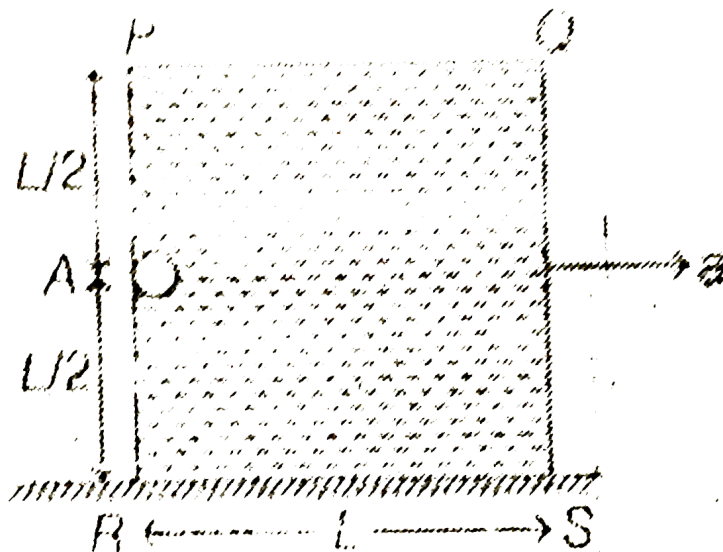

A. For ball to hit the top of container at end  $Q$ ,  $a = 3g$

B. For ball to hit the top of container at end  $Q$ ,  $a = 2g$

C. Ball hits the top of container at end  $Q$  after a time

$$t = \sqrt{\frac{L}{3g}}$$

D. Ball hits the top of container at end  $Q$  after a time

$$t = \sqrt{\frac{2L}{3g}}$$

Answer: B::C



Watch Video Solution

6. A metallic wire of length  $l$  is held between two rigid supports. If the wire is cooled through a temperature  $t$ . ( $Y$  = Young's modulus of elasticity of wire,  $\rho$  = density,  $\alpha$  = thermal coefficient of linear expansion). Then the frequency of oscillation is proportional to

A.  $\frac{1}{l}$

B.  $\sqrt{Y}$

C.  $\sqrt{Y\alpha/\rho}$

D.  $\sqrt{l}$

Answer: B

 [Watch Video Solution](#)

7. A cylinder is floating in two liquids as shown in figure.

Choose the correct options.

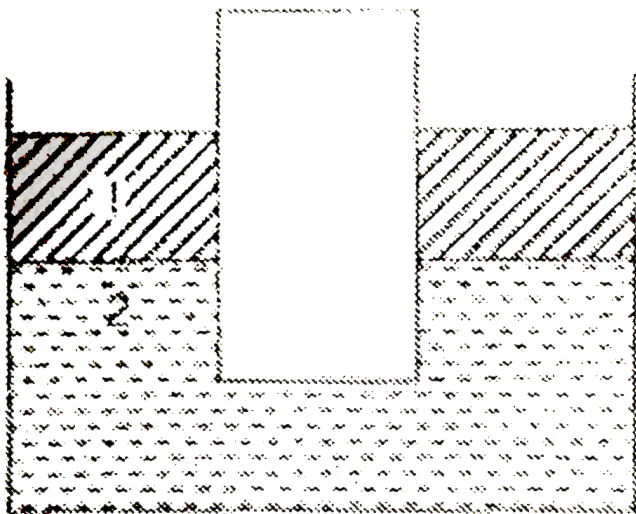

A. Net force on cylinder by liquid 1 is zero

B. Net force on cylinder by liquid 1 is non-zero

C. Net force on cylinder by liquid 2 is equal to the upthrust

D. Net force on cylinder by liquid 2 is more than the upthrust

**Answer: A::D**



**Watch Video Solution**



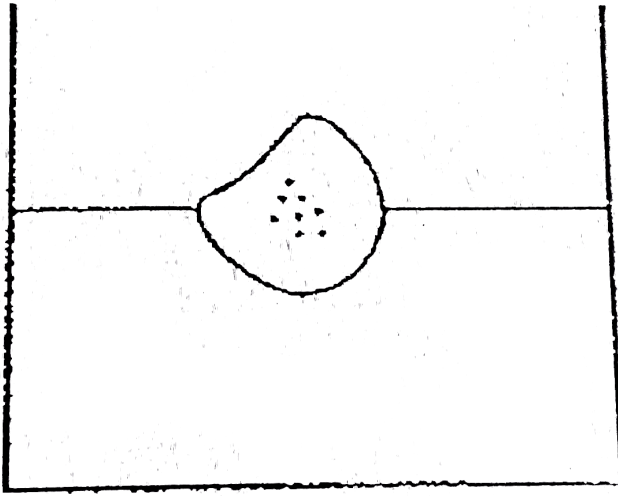

8.

Some pieces of impurity (density =  $\rho$ ) is embedded in ice.

This ice is floating in water (density  $\rho_w$ ). When ice melts

level of water will

(a). Fall if  $\rho > \rho_w$

(b). Remain unchanged if  $\rho < \rho_w$

(c). fall if  $\rho < \rho_w$

(d). rise if  $\rho > \rho_w$

A. fall if  $\rho > \rho_w$

B. remain unchanged, if  $\rho < \rho_w$

C. fall if  $\rho < \rho_w$

D. rise if  $\rho > \rho_w$

**Answer: A::B**

 [Watch Video Solution](#)

**9.** Three different liquids are filled in a U-tube as shown in figure. Their densities are  $\rho_1$ ,  $\rho_2$  and  $\rho_3$  respectively. From

the figure we may conclude that

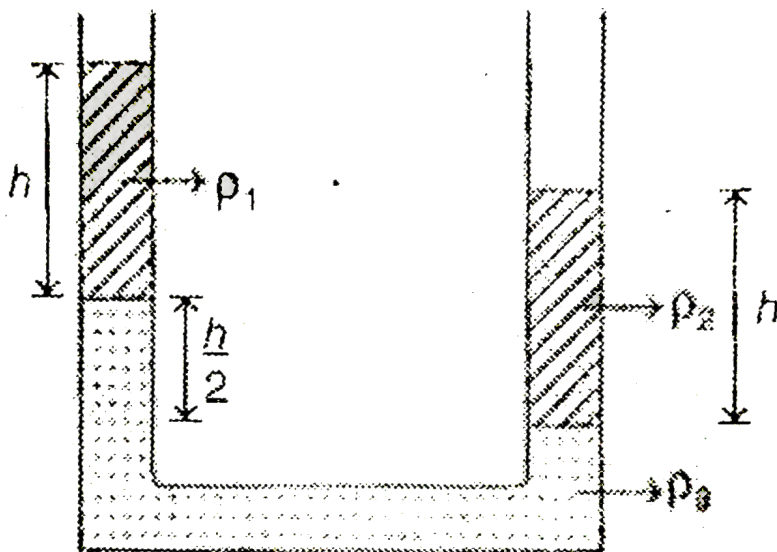

A.  $\rho_2 > \rho_1$

B.  $\rho_1 > \rho_2$

C.  $\rho_3 = 2(\rho_2 - \rho_1)$

D.  $\rho_3 = \frac{\rho_2 + \rho_1}{2}$

Answer: A:C



Watch Video Solution

10. A block is floating in a liquid as shown in figure. Suppose  $w$  = weight of block,  $p$  = pressure at bottom of block and  $F$  = upthrust on the block. Now suppose container starts moving upward with some positive acceleration. The new values are suppose  $w'$ ,  $p'$  and  $F'$ . Then

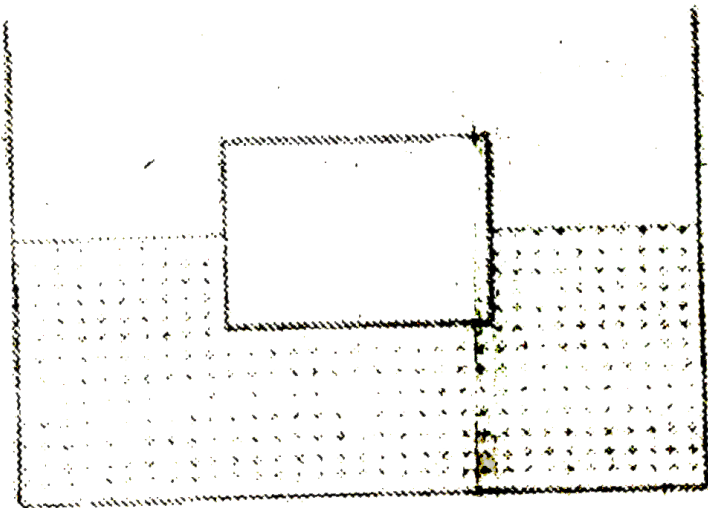

A.  $w' > w$

B.  $p' > p$

C.  $F' > F$

D.  $F' - w' = 0$

**Answer: B::C**



**Watch Video Solution**

11. For the different materials it is given that  $Y_1 > Y_2$  and  $B_1 < B_2$ . Here,  $Y$  is Young's modulus of elasticity and  $B$ , the Bulk modulus of elasticity. Then we can conclude that

A. 1 is more ductile

B. 2 is more ductile

C. 1 is more malleable

D. 2 is more malleable

**Answer: B::C**



**Watch Video Solution**

**12.** A load  $w$  is suspended from a wire of length  $l$  and area of cross-section  $A$ . Change in length of the wire is say  $\Delta l$ . Change in length  $\Delta l$  can be increased to two times by increasing

- A.  $w$  by two times
- B.  $l$  by two times
- C.  $A$  by two times
- D.  $A$  by four times

**Answer: A::B**

 [Watch Video Solution](#)

13. The viscous force acting on a solid ball of surface area.  $A$  moving with terminal velocity  $v$  is proportional to

A.  $A$

B.  $A^{1/2}$

C.  $V$

D.  $V^{1/2}$

**Answer: B::C**

 [Watch Video Solution](#)

14. An oil drop falls through air with a terminal velocity of  $\frac{5 \times 10^{-4}}{\text{sec}}$  viscosity of air is  $1.8 \times 10^{-5} \frac{\text{N} \cdot \text{s}}{\text{m}^2}$  and density of oil is  $900 \text{ kg m}^3$  neglect density of air as compared to that of oil.

A. radius of the drop is  $6.20 \times 10^{-2} \text{m}$

B. radius of the drop is  $2.14 \times 10^{-6} \text{m}$

C. terminal velocity of the drop at half of this radius is

$$1.25 \times 10^{-4} \text{m/s}$$

D. terminal velocity of the drop at half of this radius is

$$2.5 \times 10^{-4} \text{m/s}$$

**Answer: B::C**



**Watch Video Solution**



15. There are two holes on a water tank as shown in figure. Area of hole 2 is two times that of area of hole 1. Suppose  $v$  is the speed of liquid coming out and  $Q$  the volume of liquid flowing per second. Then

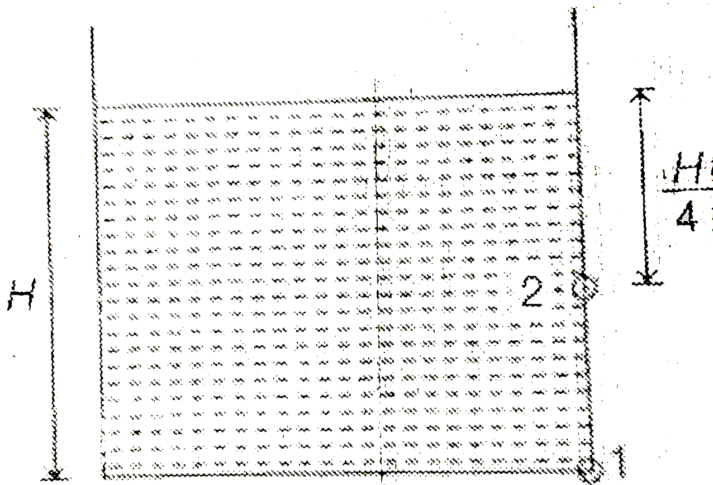

A.  $V_1 = 4V_2$

B.  $V_1 = 2V_2$

C.  $Q_1 = Q_2$

D.  $Q_1 = 2Q_2$

**Answer: B::C**



**Watch Video Solution**

**16.** A cylindrical vessel of  $90\text{cm}$  height is kept filled up to the brim. It has four holes 1, 2, 3 and 4 which are, respectively, at heights of  $20\text{cm}$ ,  $30\text{cm}$ ,  $40\text{cm}$  and  $50\text{cm}$  from the horizontal floor  $PQ$ . The water falling at the maximum horizontal

distance from the vessel comes from

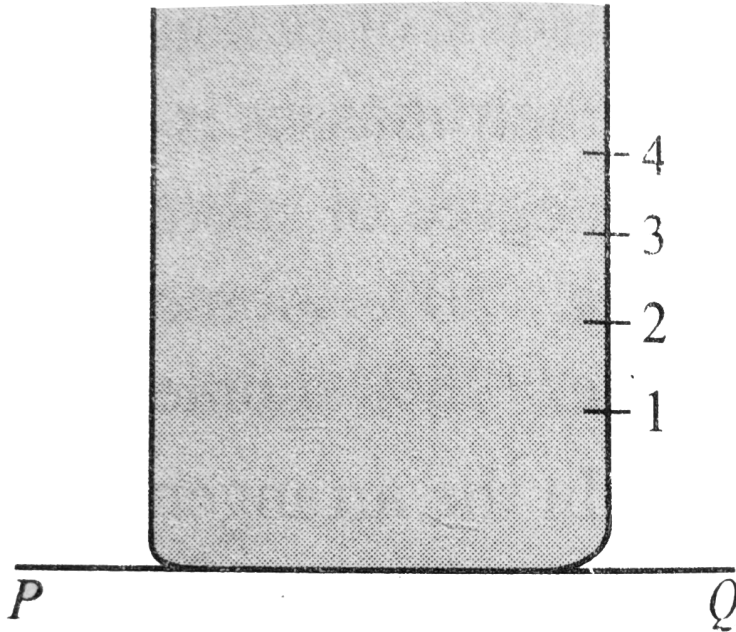

- A. hole number 4
- B. hole number 3
- C. hole number 2
- D. hole number 1

**Answer: A::B**



17. A block of density  $2000\text{kg}/\text{m}^3$  and mass  $10\text{kg}$  is suspended by a spring stiffness  $100\text{N}/\text{m}$ . The other end of the spring is attached to a fixed support. The block is completely submerged in a liquid of density  $1000\text{kg}/\text{m}^3$ . If the block is in equilibrium position.

A. the elongation of the spring is  $1\text{ cm}$

B. the magnitude of buoyant force acting on the block is

$50\text{ N}$

C. the spring potential energy is  $12.5\text{ J}$

D. magnitude of spring force on the block is greater than the weight of the block

**Answer: B::C**



**Watch Video Solution**

**18.** If for a liquid in a vessel force of cohesion is twice of adhesion

- A. the meniscus will be convex upwards
- B. the angle of contact will be obtuse
- C. the liquid will descend in the capillary tube
- D. the liquid will not wet the solid

**Answer: A::B::D**



**Watch Video Solution**

19. When a capillary tube is dipped into a liquid, the liquid neither rises nor falls in the capillary.

- A. The angle of contact may be  $0^\circ$
- B. The angle of contact may be  $90^\circ$
- C. The surface tension of liquid may be infinite
- D. The surface tension of liquid may be zero

**Answer: B::D**

 [Watch Video Solution](#)

20. The wires  $A$  and  $B$  shown in Fig. are made of the same material and have radii  $r_A$  and  $r_B$ , respectively. The block between them has a mass  $m$ . When the force  $F$  is  $mg/3$ ,

one of the wires breaks. Then

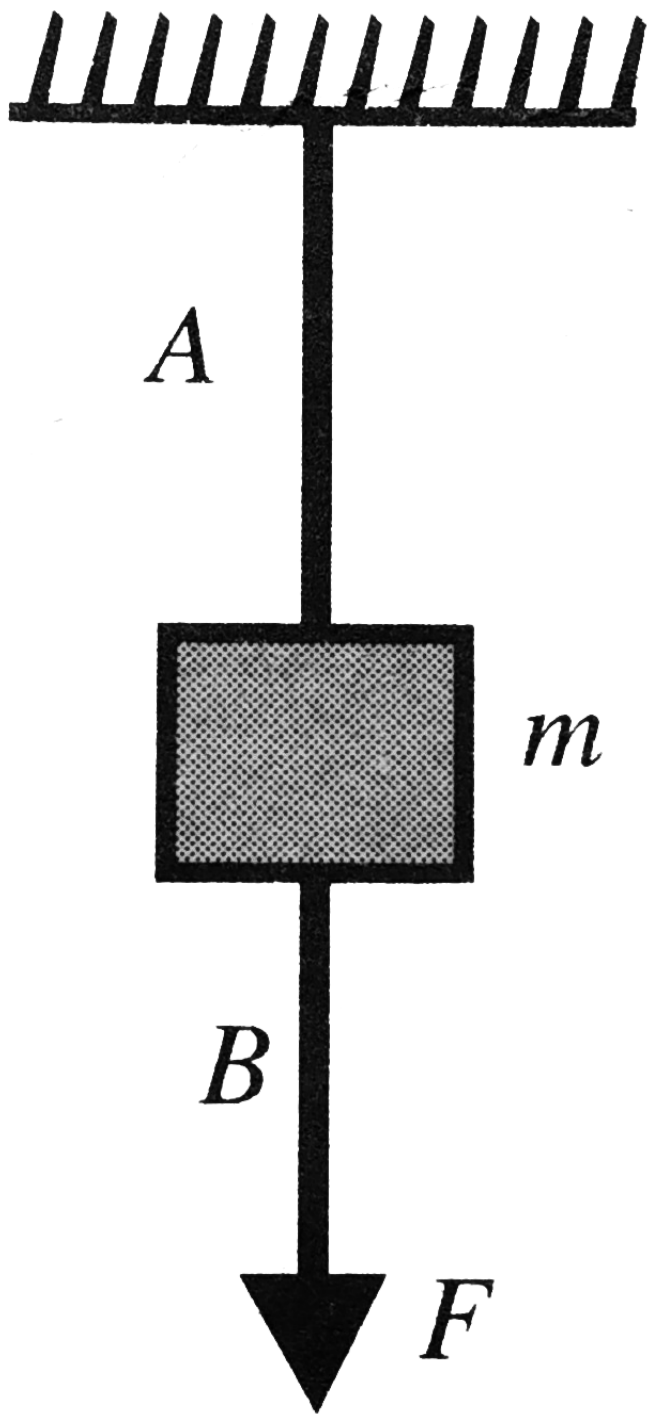



A. A breaks if  $r_A = r_B$

B. A breaks if  $r_A < r_B$

C. Either A or B may break if  $r_A = 2r_B$

D. The length of A and B must be known to predict which wire will break.

**Answer: A::B::C**



**Watch Video Solution**

**21.** A small block of wood of density  $0.4 \times 10^3 \text{ kg/m}^3$  is submerged in water at a depth of  $2.9 \text{ m}$ . Find

(a) the acceleration of the block towards the surface when the block is released and

(b) the time for the block to reach the surface, ignore viscosity.

A. Acceleration of block towards the surface is  $14.7 \text{ m/s}^2$

B. Velocity of block after 3 s is  $29.4 \text{ m/s}$

C. Time taken by the block to reach the surface is 0.63 s

D. Time taken by the block to reach the surface is 2.74 s

**Answer: A::C**



**Watch Video Solution**

**Comprehension**

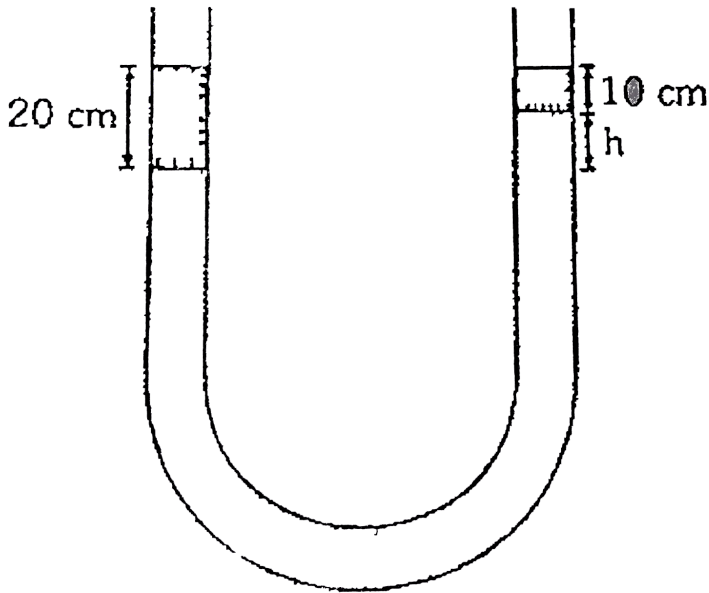

1.

In a U-tube if different liquids are filled then we can say that pressure at same level of same liquid is same.

Q. In a U-tube 20 cm of a liquid of density  $\rho$  is on left hand side and 10 cm of another liquid of density  $1.5 \rho$  is on right hand side in between them there is a third liquid of density  $2\rho$  what is the value of  $h$ .

A. 5 cm

B. 2.5 cm

C. 2 cm

D. 7.5 cm

**Answer: B**



**Watch Video Solution**

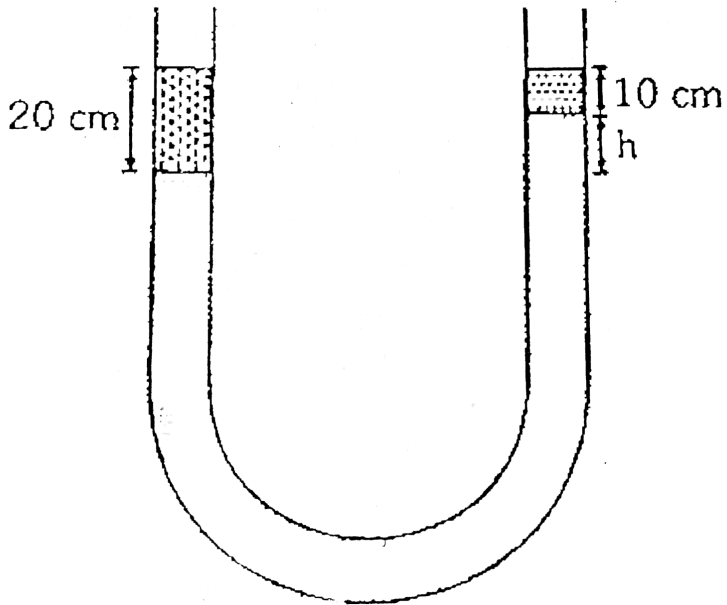

2.

In a U-tube if different liquids are filled then we can say that pressure at same level of same liquid is same.

Q. If small but equal lengths of liquid -1 and liquid -2 are increased in their corresponding sides then  $h$  will

A. remain same

B. increase

C. decrease

D. may increase or decrease

Answer: C

 [Watch Video Solution](#)

3. Liquid is filled in a vessel of square base ( $2m \times 2m$ ) upto a height of  $2m$  as shown in figure (i). In figure (ii) the vessel is tilted from horizontal at  $30^\circ$ .

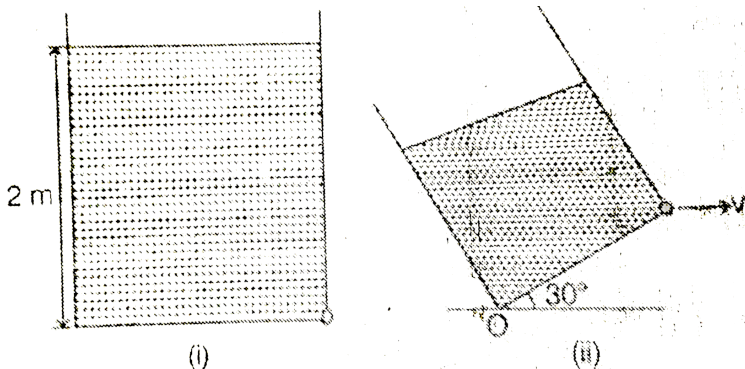

What is the velocity of efflux in this case. Liquid does not spill out?

A.  $3.20m / s$

B.  $4.96m / s$

C.  $5.67cm$

D.  $2.68m / s$

**Answer: B**

 [Watch Video Solution](#)

4. Liquid is filled in a vessel of square base ( $2m \times 2m$ ) upto a height of  $2m$  as shown in figure (i). In figure (ii) the vessel is tilted from horizontal at  $30^\circ$ .

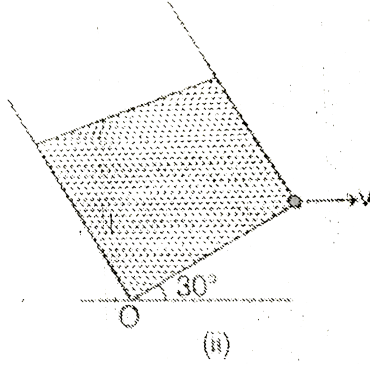
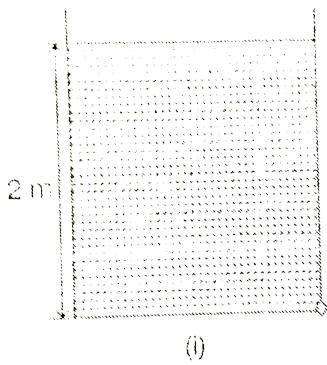

What is time of fall of liquid on the ground?

A. (a)  $\frac{1}{\sqrt{2}} s$

B. (b)  $\frac{1}{\sqrt{3}} s$

C. (c)  $\frac{1}{\sqrt{5}} s$

D. (d)  $\sqrt{2} s$

**Answer: C**

 [Watch Video Solution](#)



5. Liquid is filled in a vessel of square base ( $2m \times 2m$ ) upto a height of 2m as shown in figure (i). In figure (ii) the vessel is tilted from horizontal at  $30^\circ$ .

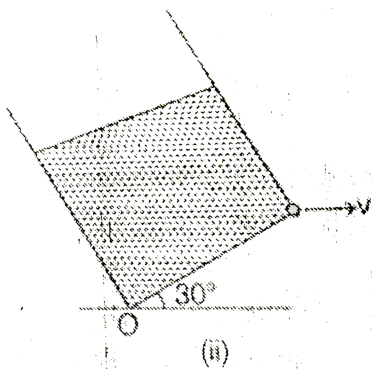
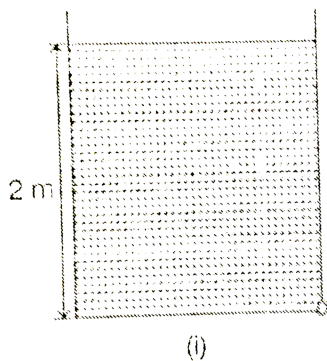

At what distance from point O, will the liquid strike on the ground?

- A. 5.24 m
- B. 6.27 m
- C. 4.93 m
- D. 3.95 m

Answer: D

 Watch Video Solution

6. A cube (side =  $10\text{cm}$ ) of density  $0.5\text{g}/\text{cm}^3$  is placed in a vessel of base area  $20\text{cm} \times 20\text{cm}$ . A liquid of density  $1.0\frac{\text{g}}{\text{cm}^3}$  is gradually filled in the vessel at a constant rate  $Q = 50\text{cm}^3/\text{s}$

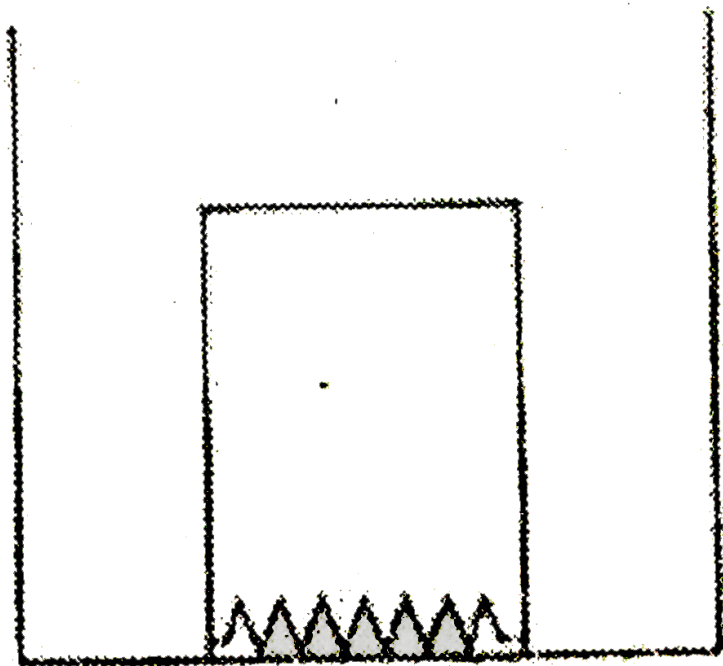

If we plot a graph between the normal reaction on cube by the vessel versus time. The graph will be like

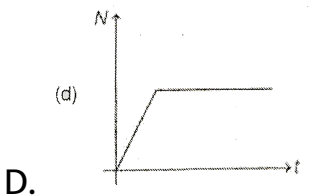
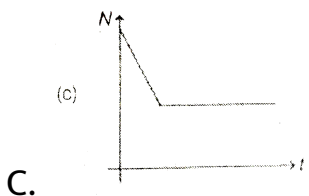
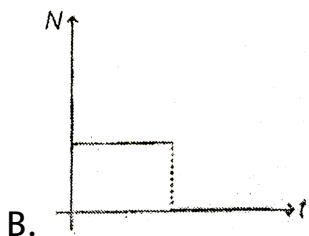
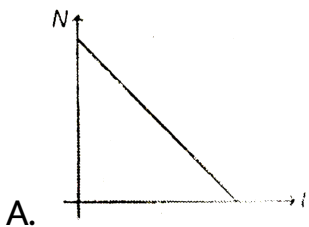

**Answer: A**

 [Watch Video Solution](#)

7. A cube (side =  $10\text{cm}$ ) of density  $0.5\text{g}/\text{cm}^3$  is placed in a vessel of base area  $20\text{cm} \times 20\text{cm}$ . A liquid of density  $1.0\text{g}/\text{cm}^3$  is gradually filled in the vessel at a constant rate  $Q = 50\text{cm}^3/\text{s}$

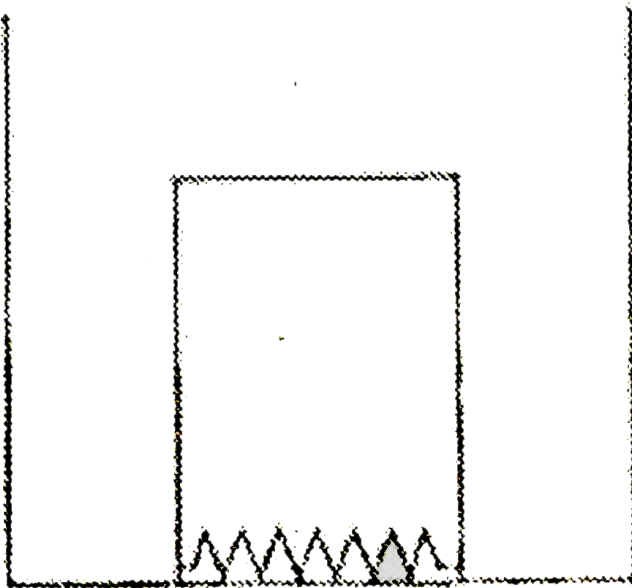

The cube will leave contact with the vessel after time  $t = \dots\dots\dots$   
s.

A. 30

B. 40

C. 60

D. 20

**Answer: A**



**Watch Video Solution**

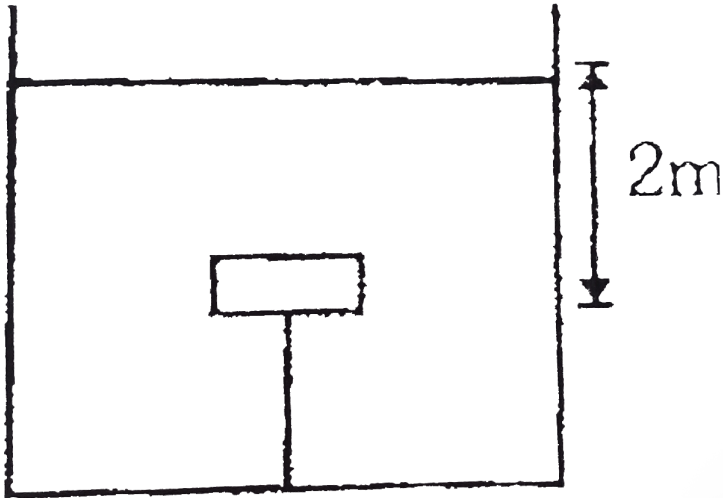

8.

Newton's laws of motion can be applied to a block in liquid also force due to liquid (e.g. upthrust) are also considered in addition to other forces. A small block of weight  $W$  is kept inside. The block is attached with a string connected to the bottom of the vessel. Tension in the string is  $W/2$

Q. The string is cut. find the time when it reaches the surface of the liquid

A.  $\frac{1}{\sqrt{5}}s$

B.  $\sqrt{5}s$

C.  $\sqrt{3}s$

D.  $\frac{2}{\sqrt{5}}s$

Answer: D

 Watch Video Solution

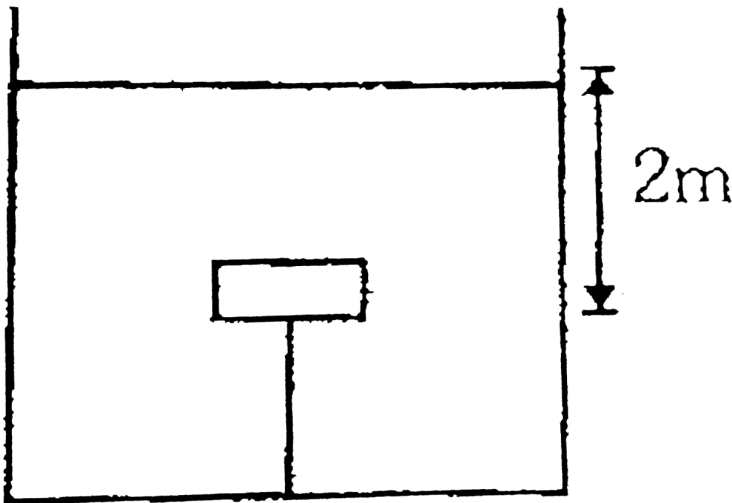

9.

Newton's laws of motion can be applied to a block in liquid

also force due to liquid (e.g. upthrust) are also considered in addition to to other forces. A small block of weight  $W$  is kept inside. The block is attached with a string connected to the bottom of the vessel. Tension in the string is  $W/2$

If weight of the block is doubled then tension in the string becomes  $x$  times and the length calculated from above becomes  $y$  times then

A. (a)  $x = 2$

B. (b)  $y = \sqrt{2}$

C. (c) both (a) and (b) are correct

D. (d) both (a) and (b) are wrong

**Answer: A**



**Watch Video Solution**



10. Two holes are made at depths  $h$  and  $2h$  from the top. A liquid of density  $\rho$  and height  $h$  is filled over another liquid of density  $2\rho$ . Speeds of liquid ejecting from two holes are say  $v_1$  and  $v_2$ .

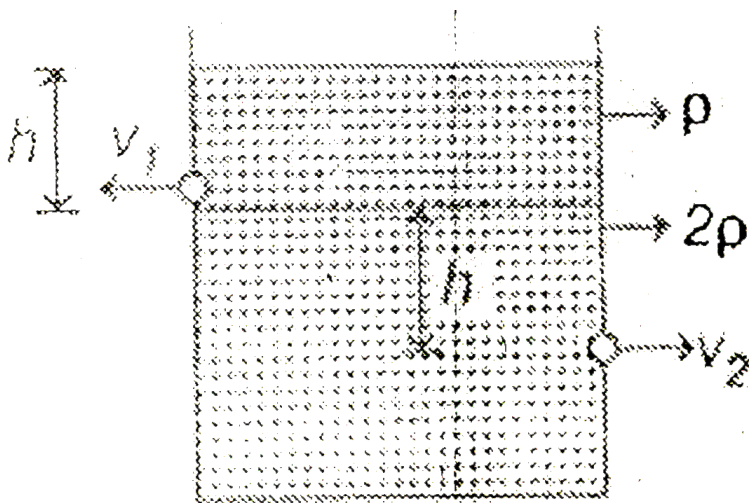

The ratio  $\frac{v_1}{v_2}$  will be

A.  $\sqrt{\frac{1}{3}}$

B.  $\sqrt{\frac{1}{2}}$

C.  $\sqrt{\frac{2}{3}}$

D.  $\sqrt{\frac{4}{3}}$

**Answer: C**



**Watch Video Solution**

**11.** Two holes are made at depths  $h$  and  $2h$  from the top. A liquid of density  $\rho$  and height  $h$  is filled over another liquid of density  $2\rho$ . Speeds of liquid ejecting from two holes are say  $v_1$  and  $v_2$ .

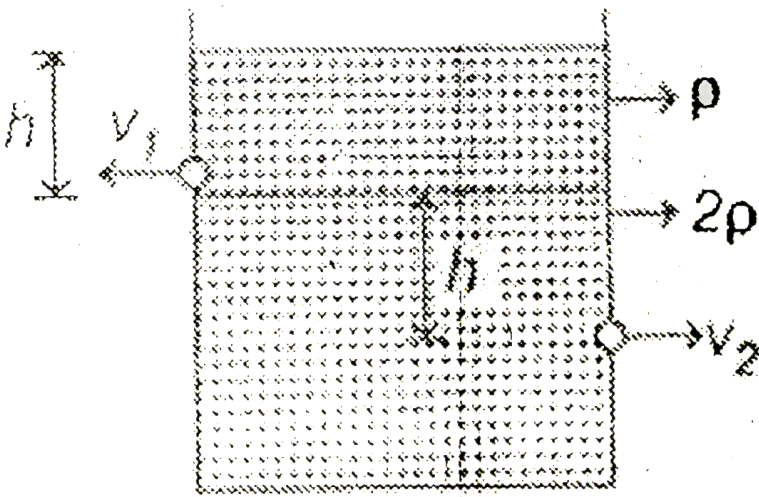

If density of lower liquid is increased

- A.  $V_1$  will decrease while  $V_2$  will increase
- B.  $V_1$  will remain as it is while  $V_2$  will increase
- C.  $V_1$  will remain as it is while  $V_2$  will decrease
- D.  $V_1$  and  $V_2$  both will decrease

**Answer: C**

[Watch Video Solution](#)

12. A cubical vessel (open from top) of side  $L$  is filled with a liquid of density  $\rho$ .

What is the torque of hydrostatic force on a side wall about an axis passing through one of the bottom edges?

A.  $\frac{\rho g L^4}{4}$

B.  $\frac{\rho g L^4}{6}$

C.  $\frac{2\rho g L^4}{3}$

D.  $\frac{\rho g L^4}{3}$

**Answer: B**



**Watch Video Solution**

**13.** A cubical vessel (open from top) of side  $L$  is filled with a liquid of density  $\rho$ .

What is the ratio of magnitude of torque on one side wall to the torque on base about the same axis

A. 1:1

B. 1:2

C. 1:3

D. 1:4

**Answer: C**



**Watch Video Solution**

14. A siphon tube is discharging a liquid of specific gravity 0.9 from a reservoir as shown in the figure.

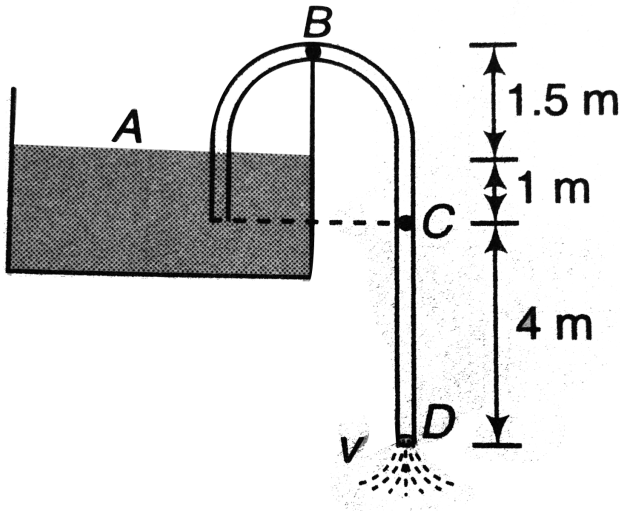

- Find the velocity of the liquid through the siphon.
- Find the pressure at the highest point B.
- Find the pressure at point C.

A. 6 m/s

B. 8 m/s

C. 10 m/s

D. 12 m/s

**Answer: C**



**Watch Video Solution**

**15.** A siphon tube is discharging a liquid of density

$900 \frac{\text{kg}}{\text{m}^3}$  as shown in figure. ( $P_0 = 1.01 \times 10^5 \text{ N/m}^2$ )

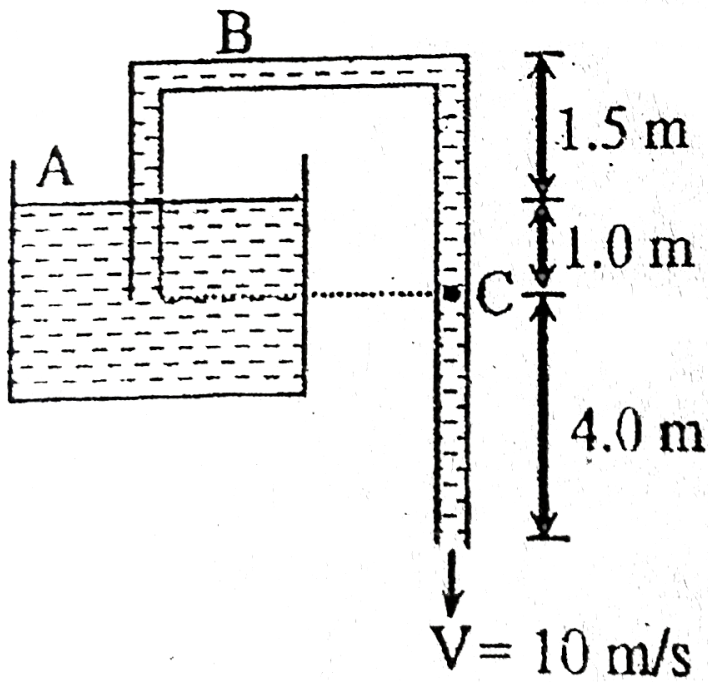

Pressure at point B is

- A.  $4.25 \times 10^4 \text{ N/m}^2$
- B.  $6.25 \times 10^4 \text{ N/m}^2$
- C.  $2.50 \times 10^4 \text{ N/m}^2$
- D.  $2.0 \times 10^5 \frac{\text{N}}{\text{m}^2}$

Answer: A



16. A siphon tube is discharging a liquid of density  $900 \frac{kg}{m^3}$  as shown in figure. ( $P_0 = 1.01 \times 10^5 N/m^2$ )

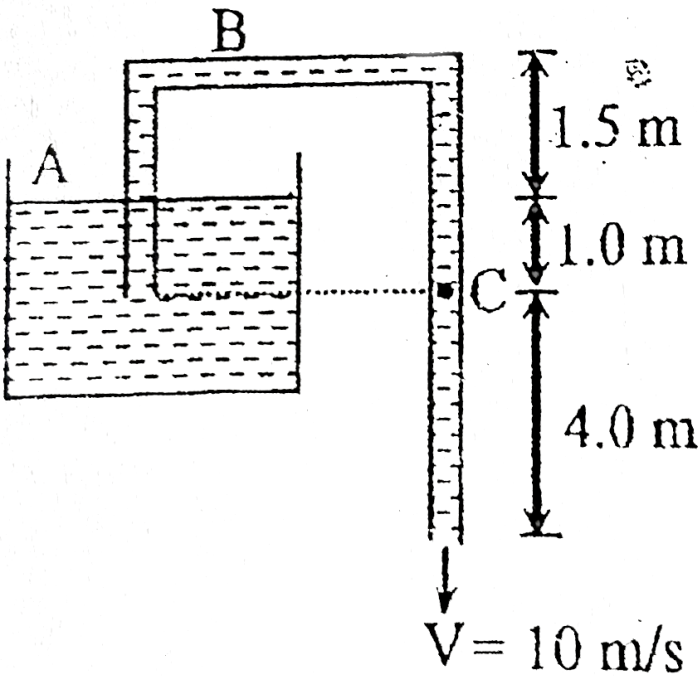

Pressure at point C is

A.  $5.5 \times 10^4 N/m^2$

B.  $6.5 \times 10^4 N/m^2$

C.  $8.0 \times 10^4 \text{ N/m}^2$

D.  $10.5 \times 10^4 \text{ N/m}^2$

**Answer: B**



**Watch Video Solution**

17. Choose the correct option:

A capillary tube of radius  $r$  is lowered into a liquid of surface tension  $T$  and density  $\rho$ . Given angle of contact  $= 0^\circ$ .

The work done by surface tension will be

A. (a)  $\frac{\pi T^2}{\rho g}$

B. (b)  $\frac{4\pi T^2}{\rho g}$

C. (c)  $\frac{T^2}{\rho g}$

D. (d)  $\frac{2T^2}{\rho g}$

**Answer: B**



**Watch Video Solution**

**18.** A capillary tube of radius  $r$  is lowered into a liquid of surface tension  $T$  and density  $\rho$ . Given angle of contact  $= 0^\circ$ .

What is the potential energy acquired by the liquid in the capillary?

A.  $\frac{\pi T^2}{2\rho g}$

B.  $\frac{T^2}{2\rho g}$

C.  $\frac{T^2}{\rho g}$

D.  $\frac{2\pi T^2}{\rho g}$

**Answer: D**



**Watch Video Solution**

**19.** A long glass capillary (radius  $R$ ) is taken out of liquid (surface tension  $S$  and density  $\rho$ ) in vertical position. Angle of contact everywhere is zero. Atmospheric pressure is  $P_0$ . It is observed that the capillary retains some liquid.

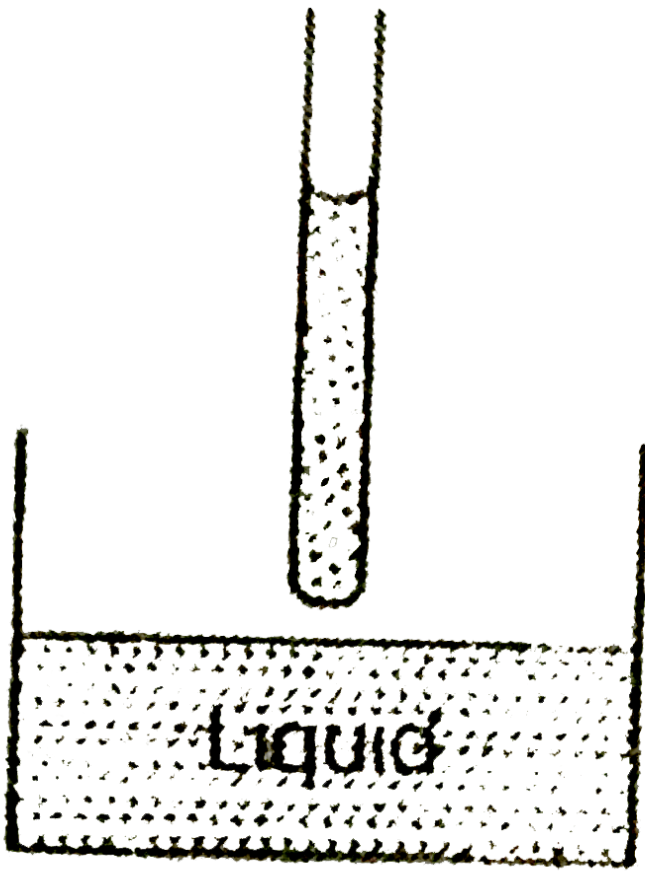

The radius of curvature of meniscus at the bottom of tube is

- A.  $R$
- B.  $\infty$
- C.  $R/2$
- D.  $R/3$

**Answer: A**



**Watch Video Solution**

**20.** A long glass capillary (radius  $R$ ) is taken out of liquid (surface tension  $S$  and density  $\rho$ ) in vertical position. Angle of contact everywhere is zero. Atmospheric pressure is  $P_0$ . It is observed that the capillary retains some liquid.

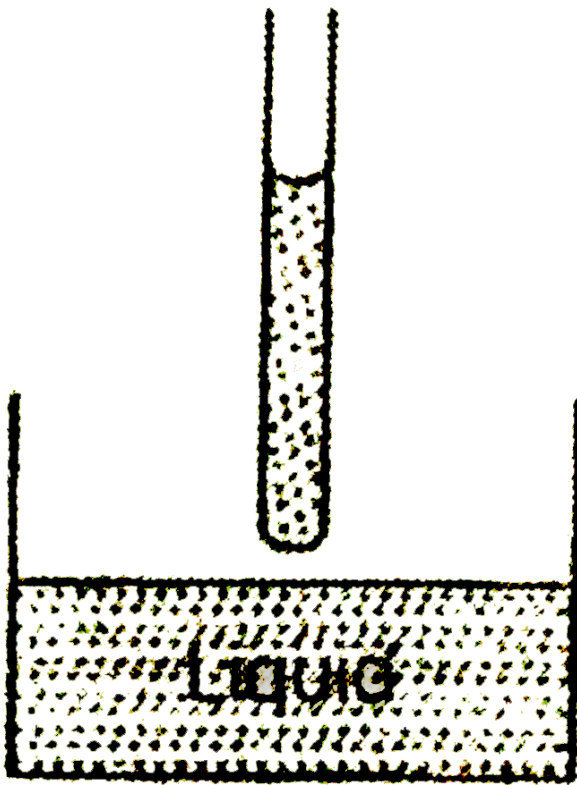

The length of liquid column retained in the capillary is

- A.  $\frac{3S}{\rho Rg}$
- B.  $\frac{2S}{\rho Rg}$
- C.  $\frac{4S}{\rho Rg}$
- D. zero

Answer: B

 Watch Video Solution

21. In two identical communicating vessel we poured water

(see picture). In one of them we put an ice ball of volume

$V = 100\text{cm}^3$  which gets exactly half immersed in the water.

The density of water  $\rho_w = 1000\text{kg}/\text{m}^3$  the density of ice

$\rho_i = 900\text{kg}/\text{m}^3$

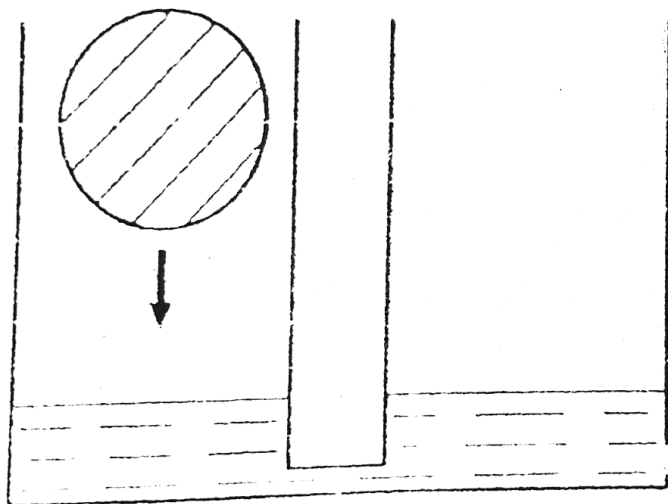



Select the correct statement (s). Soon after placing the ice ball in left vessel.

- A. The volume of water flowing to the right vessels is more than 25cc.
- B. The volume of water flowing to the right vessels is less than 25cc.
- C. The ice ball is resting on the bottom of vessel.
- D. The ice ball is floating on the water surface.

**Answer: A::C**



**Watch Video Solution**

22. In two identical communicating vessel we poured water (see picture). In one of them we put an ice ball of volume  $V = 100\text{cm}^3$  which gets exactly half immersed in the water. The density of water  $\rho_w = 1000\text{kg}/\text{m}^3$  the density of ice  $\rho_i = 900\text{kg}/\text{m}^3$

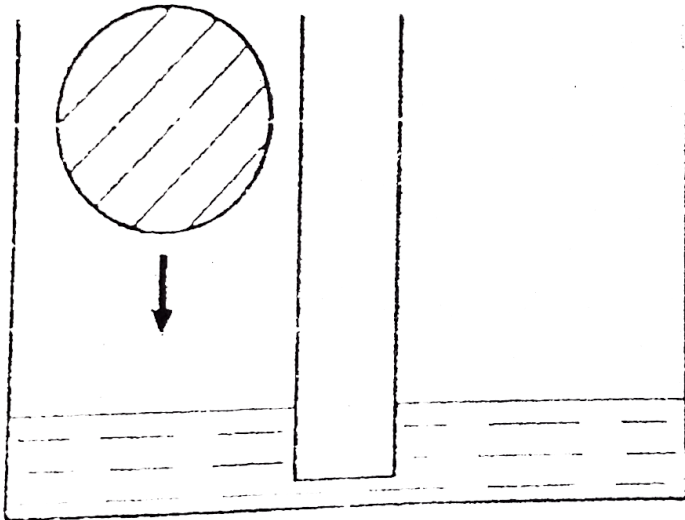

After a long time, select the correct statement (s)

A. If ice melts, the level of water in both vessel will rise.

B. If water freezes, such that ball's radius increases, the level of water in both vessel will fall.

C. If ice melts, the level of water in left vessel will rise and level of water in right vessel will fall.

D. If water freezed such that ball radius increases, the level of water in left vessel fall and level of water in right vessel will rise.

**Answer: A::B**

 [Watch Video Solution](#)

**23.** Soap bubble of radius  $R$  is blown at one end of a pipe of circular of circular cross-section of radius  $R$  as shown in

diagram. On the vertical portion of pipe, there is a piston of mass  $m$ .  $T$  is surface tension of liquid.

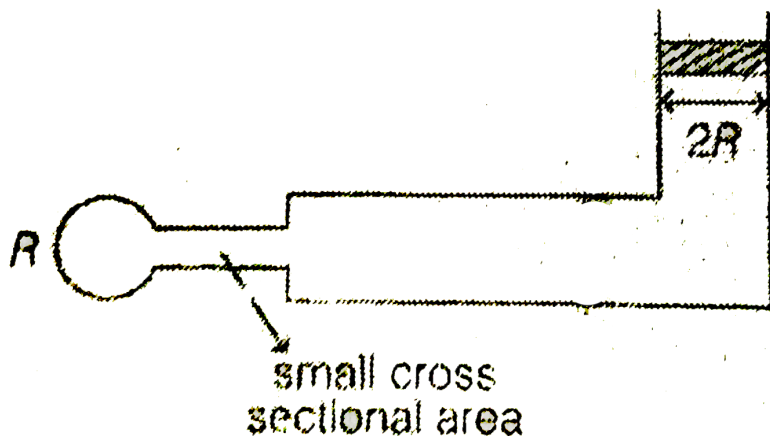

Find the mass of piston for which it remain in equilibrium

A.  $\frac{4\pi TR}{g}$

B.  $\frac{2\pi TR}{g}$

C.  $\frac{4TR}{g}$

D.  $\frac{4TR^2}{g}$

**Answer: A**



24. Soap bubble of radius  $R$  is blown at one end of a pipe of circular of circular cross-section of radius  $R$  as shown in diagram. On the vertical portion of pipe, there is a piston of mass  $m$ .  $T$  is surface tension of liquid.

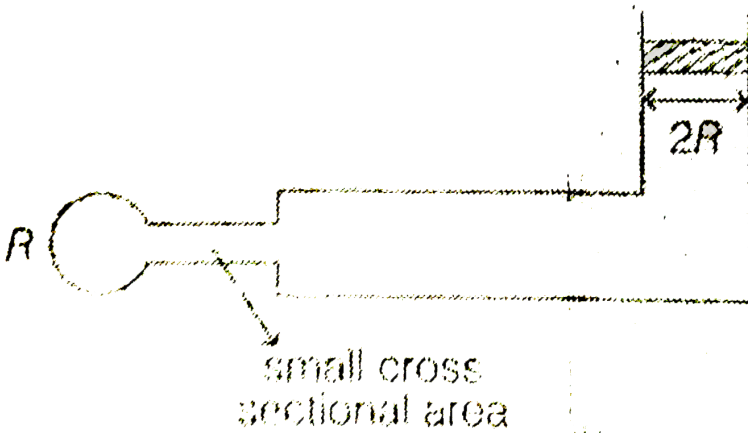

If piston is slightly displaced in downward direction, then its acceleration when radius of bubble grows to  $2R$  is

- A. zero
- B.  $g/2$

C.  $g/3$

D.  $g/4$

**Answer: B**

 [Watch Video Solution](#)

**25.** A container contains three liquids as shown in the figure. The specific gravity of liquid 1 and liquid 2 are 0.8 and 1.2 respectively. A small hole having area  $10^{-6} m^2$  at point P is as shown in the figure. Initially hole is closed. The cross-sectional area of container is  $50 cm^2$ . assume all liquids are ideal and neglect any type of friction between liquid and container. (Given that  $g = 9.8 m/s^2$  and  $h = 28 cm$ )

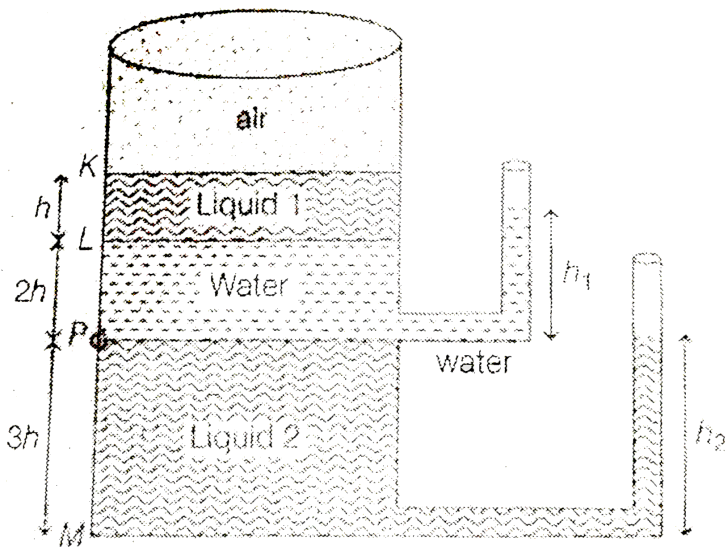

The value of  $h_2/h_1$  is

- A.  $9/5$
- B.  $20/7$
- C.  $40/21$
- D.  $40/7$

**Answer: C**

 **Watch Video Solution**

26. A container contains three liquids as shown in the figure. The specific gravity of liquid 1 and liquid 2 are 0.8 and 1.2 respectively. A small hole having area  $10^{-6}m^2$  at point P is as shown in the figure. Initially hole is closed. The cross-sectional area of container is  $50cm^2$ . assume all liquids are ideal and neglect any type of friction between liquid and container. (Given that  $g = 9.8m/s^2$  and  $h = 28cm$ )

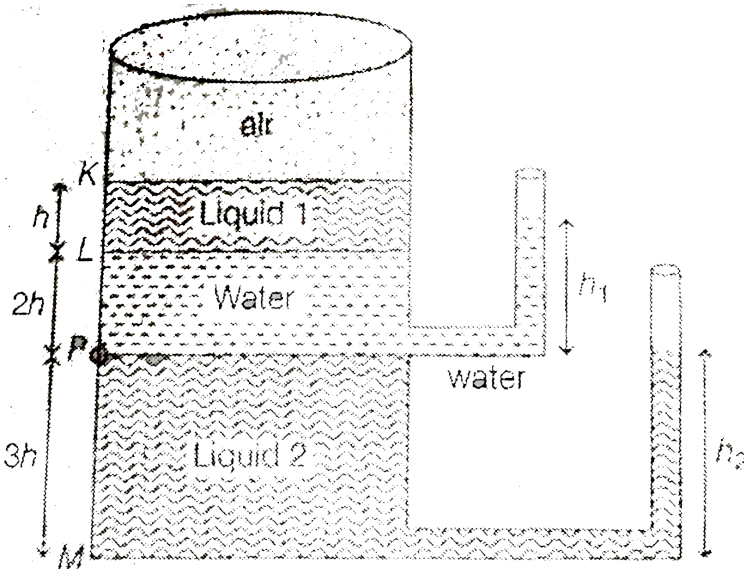



At some instant, hole is opened. the speed of water coming out from hole just after the opening of hole is

A. 7.84 m/s

B. 3.92 m/s

C. 1.96 m/s

D. None of these

**Answer: B**

 [Watch Video Solution](#)

**27.** A tank contains water on top of mercury . A cube of iron, 60mm along each edge, is sitting upright in equilibrium in the liquids. Find how much of it is in each liquid. The densities of iron and mercury are  $7.7 \times 10^3 \text{ kg/m}^3$  and

$13.6 \times 10^3 \text{ kg/m}^3$  respectively

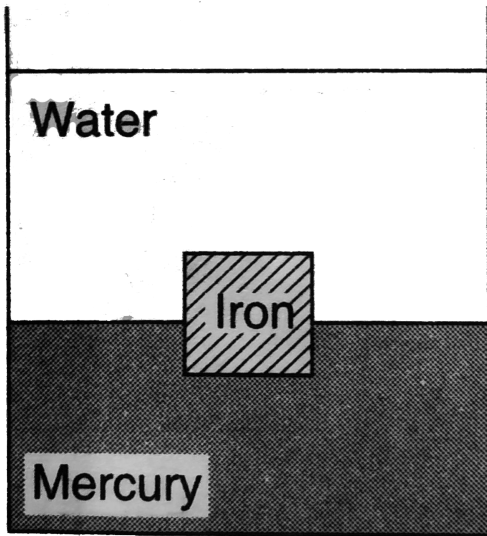

- A. 2 cm
- B. 4.5 cm
- C. 3.24 cm
- D. 2.5 cm

**Answer: C**



28. A tank contains water and mercury as shown in figure. An iron cube of edge  $d = 6$  cm is in equilibrium as shown. (density of iron  $= 7.8 \times 10^3 \text{ kg/m}^3$ , density of mercury  $= 13.6 \times 10^3 \text{ kg/m}^3$ , density of water  $= 10^3 \text{ kg/m}^3$ ) (Neglect the atmospheric pressure)

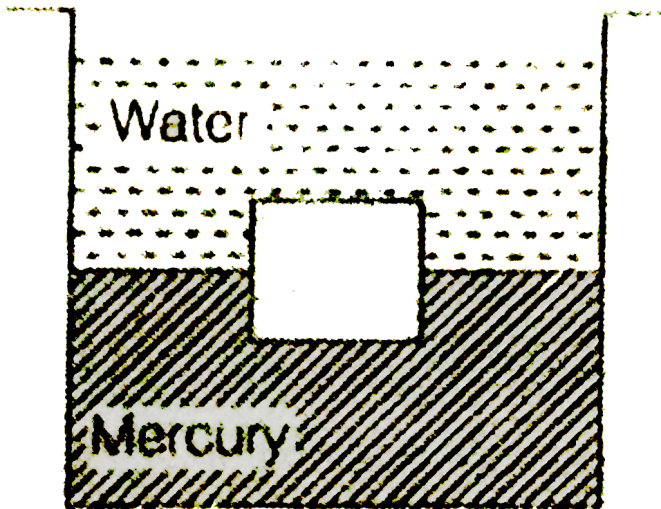

Time period of small oscillations of block is

$$A. 2\pi \sqrt{\frac{d\rho_{Fe}}{(\rho_{Hg} - \rho_W)g}}$$

B.  $2\pi \sqrt{\frac{d\rho_{Fe}}{(\rho_{Hg} + \rho_w)g}}$

C.  $2\pi \sqrt{\frac{d\rho_{Fe}}{\rho_{Hg}g}}$

D.  $2\pi \sqrt{\frac{d\rho_{Fe}}{\rho_w g}}$

**Answer: A**

 [Watch Video Solution](#)

**29.** A ring of radius  $R$  is made of a thin wire of material of density  $\rho$ , having cross-section area  $a$  and Young's modulus  $y$ . The ring rotates about an axis perpendicular to its plane and through its centre. Angular frequency of rotation is  $\omega$ .

The tension in the ring will be

A.  $\frac{a\rho R^2\omega^2}{2}$

B.  $a\rho R^2\omega^2$

C.  $2a\rho R^2\omega^2$

D.  $\frac{a\rho R^2\omega^2}{4}$

**Answer: B**

 [Watch Video Solution](#)

**30.** A ring of radius  $R$  is made of a thin wire of material of density  $\rho$ , having cross-section area  $a$  and Young's modulus  $y$ . The ring rotates about an axis perpendicular to its plane and through its centre. Angular frequency of rotation is  $\omega$ .

The ratio of kinetic energy to potential energy is

A.  $\frac{y}{\rho R^2\omega^2}$

B.  $\frac{2y}{\rho R^2 \omega^2}$

C.  $\frac{y}{2\rho R^2 \omega^2}$

D.  $\frac{y}{4\rho R^2 \omega^2}$

**Answer: A**

 [Watch Video Solution](#)

**31.** A thin uniform copper rod length  $l$  and mass  $m$  rotates uniformly with an angular velocity  $\omega$  about a vertical axis passing through one of its ends as shown in the figure. Young's modulus of copper is  $Y$ . Breaking stress is  $\sigma_{\max}$ , cross sectional area of rod is  $A$  and density of rod is uniform. Based on above information, answer the following questions

The maximum angular velocity with which the rod can rotate

so that is won't break, is

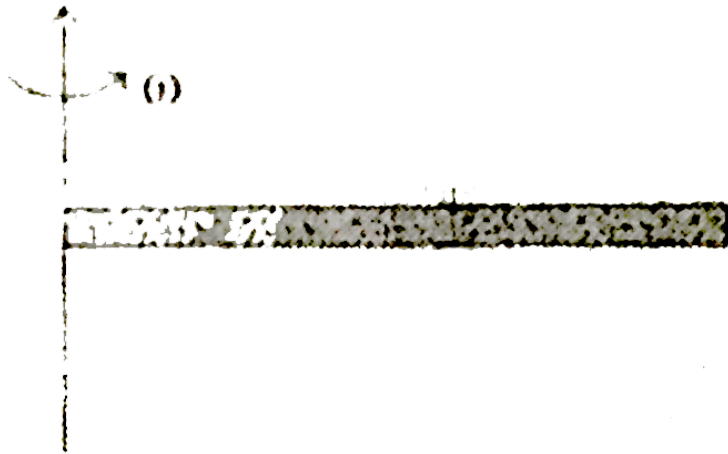

A.  $\sqrt{\frac{2\sigma_{\max} A}{ml}}$

B.  $\sqrt{\frac{2\sigma_{\max} A}{3ml}}$

C.  $\sqrt{\frac{\sigma_{\max} A}{2ml}}$

D.  $\sqrt{\frac{3\sigma_{\max} A}{ml}}$

**Answer: A**

 [Watch Video Solution](#)

32. A uniform rod of length  $l$ , mass  $m$ , cross-sectional area  $A$  and Young's modulus  $Y$  is rotated in horizontal plane about a fixed vertical axis passing through one end, with a constant angular velocity  $\omega$ . Find the total extension in the rod due to the tension produced in the rod.

A.  $\frac{2m\omega^2 l^2}{3AY}$

B.  $\frac{m\omega^2 l^2}{AY}$

C.  $\frac{m\omega^2 l^2}{3AY}$

D.  $\frac{5m\omega^2 l^2}{48AY}$

**Answer: C**



**Watch Video Solution**



## 1. Match the following

Table-1

- (A) Steel
- (B) Water
- (C) Hydrogen gas filled in a chamber

Table-2

- (P) Young's modulus of elasticity
- (Q) Bulk modulus of elasticity
- (R) shear modulus of elasticity



[Watch Video Solution](#)

## 2. Match the following.

Table-1

- (A) Coefficient of viscosity
- (B) Surface tension
- (C) Modulus of elasticity
- (D) Energy per unit volume of a fluid

Table-2

- (P)  $[M^2L^{-1}T^{-2}]$
- (Q)  $[ML^0T^{-2}]$
- (R)  $[ML^{-1}T^{-2}]$
- (S) None

3. A tube is inverted in a mercury vessel as shown in figure. If pressure  $P$  is increased, then

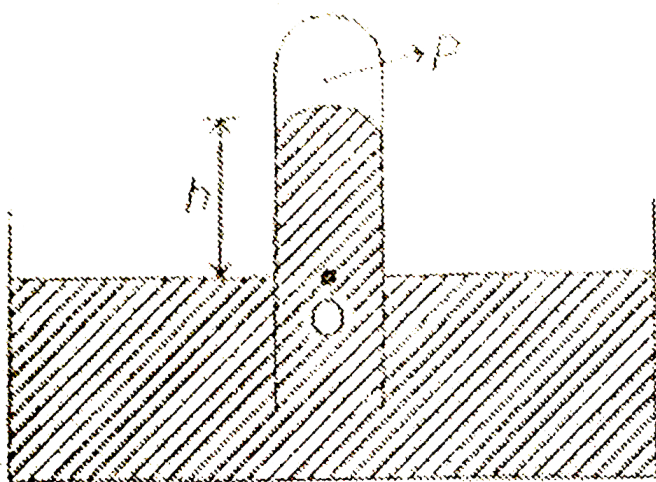

Table-1

- (A) Height  $h$
- (B) Pressure at  $O$
- (C) Pressure at 1 cm above  $O$

Table-2

- (P) will increase
- (Q) will decrease
- (R) will remain same

4. In the figure shown, velocity of liquid which comes out is  $v$ , time of liquid to fall to ground is  $t$  and range on ground is  $R$ . If the vessel is taken to a mountain, match the following.

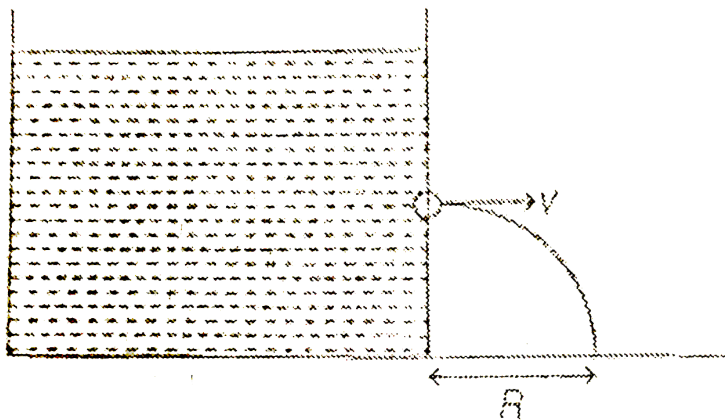
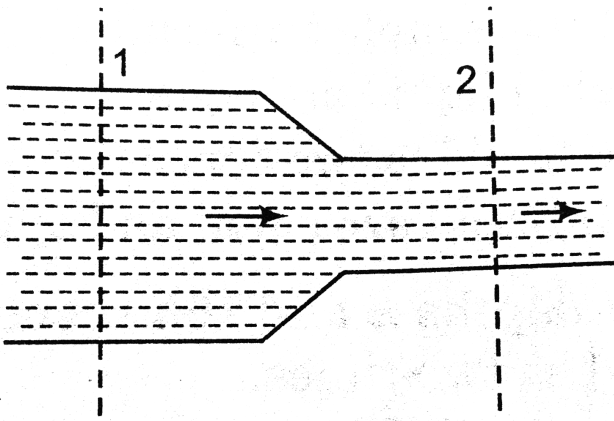

	Table-1	Table-2
(A)	$V$	(P) will increase
(B)	$t$	(Q) will decrease
(C)	$R$	(R) will remain same



**Watch Video Solution**

5. A non viscous incompressible liquid is flowing from a horizontal pipe of non-uniform cross section as shown, Choose the correct option



[Watch Video Solution](#)

6. There are two point A and B inside a liquid as shown in figure. Now the vessel starts moving upwards with an acceleration  $a$ . Match the following.

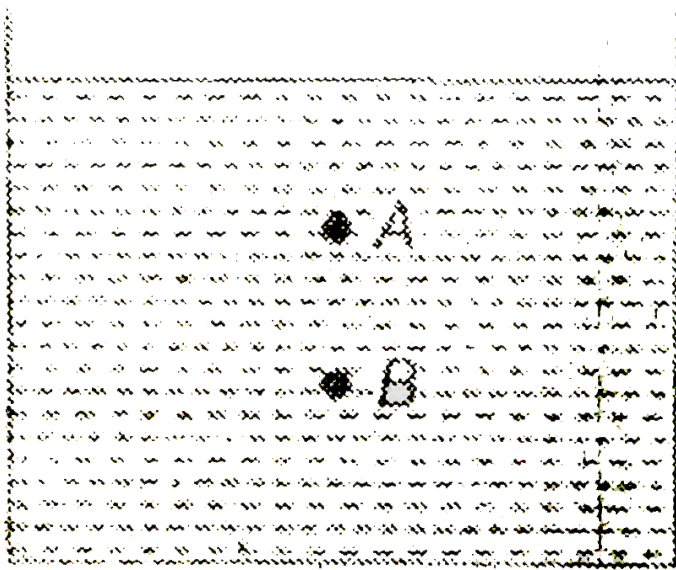

Table-1

Table-2

- |   |                 |
|---|-----------------|
| (A) Pressure at B will                              | (P) increase    |
| (B) Pressure difference<br>between A and B will     | (Q) decrease    |
| (C) Upthrust on an object<br>inside the vessel will | (R) remain same |

 [Watch Video Solution](#)

7. Two soap bubbles coalesce to form a single large drop.

Match the following.

Table-1

Table-2

(A) Surface energy in the process will

(P) increase

(B) Temperature of the drop will

(Q) decrease

(C) Pressure inside the soap bubble will

(R) remain same



**Watch Video Solution**

**8.** A cube is floating in a liquid as shown in figure. Match the following.

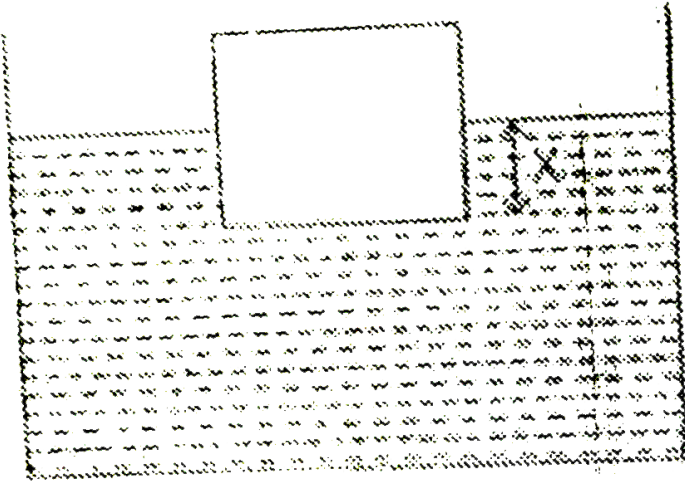

Table-1

Table-2

- |   |                 |
|---|-----------------|
| (A) If density liquid decreases $x$ will                | (P) increase    |
| (B) If size of cube is increased $x$ will               | (Q) decrease    |
| (C) If the whole system is accelerated upwards $x$ will | (R) remain same |



[Watch Video Solution](#)

9. A solid is immersed completely in a liquid. The temperature coefficients of volume expansion of solid and

the liquid are  $\gamma_1$  and  $\gamma_2$  ( $< \gamma_1$ ). If temperatures of both are increased, then match the following.

Table-1

- (A) upthrust on the solid will
- (B) apparent weight of the solid will
- (C) fraction of volume immersed in the liquid if allowed to float will

Table-2

- (P) increase
- (Q) decrease
- (R) remain same



[Watch Video Solution](#)

10. In the figures shown, match the following

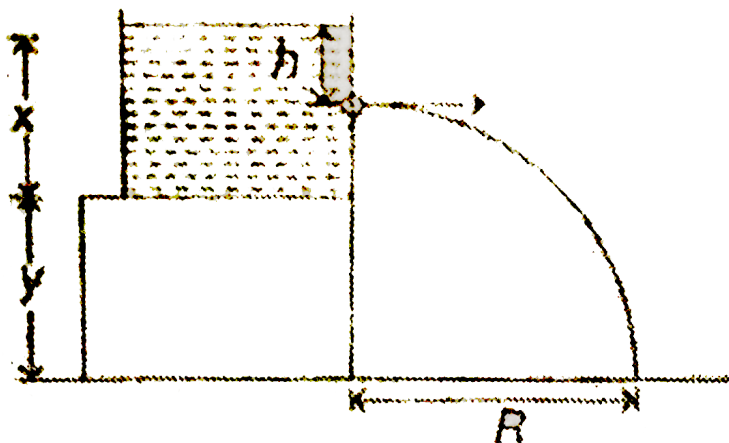



Table-1

Table-2

$$(A) \quad x = 2h, \quad y = h \quad (P) \quad R = 2\sqrt{3}h$$

$$(B) \quad x = h, \quad y = 3h \quad (Q) \quad R = 2\sqrt{2}h$$

$$(C) \quad x = 3h, \quad y = h \quad (R) \quad R = 2h$$



Watch Video Solution

11. Match the following

Table-1

Table-2

$$(A) \quad \text{Stress} \times \text{Strain} \quad (P) \quad J$$

$$(B) \quad \frac{YA}{l} \quad (Q) \quad N/m$$

$$(C) \quad Yl^3 \quad (R) \quad J/m^3$$

$$(D) \quad \frac{Fl}{AY} \quad (S) \quad m$$



Watch Video Solution

12. A ball is thrown downward in a viscous fluid with speed  $V$ .

Terminal speed of ball is  $V_0$

Table-1

(A)  $V = 0$

(B)  $0 < V < V_0$

(C)  $V > V_0$

(D)  $0 < V < V_0$  but density of ball is less than density of fluid [in previous cases density of ball is greater than density of fluid]

Table-2

(P)



(Q)

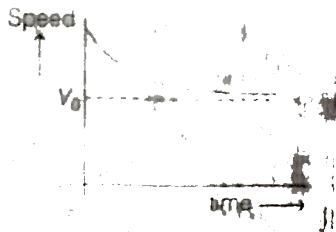

(R)

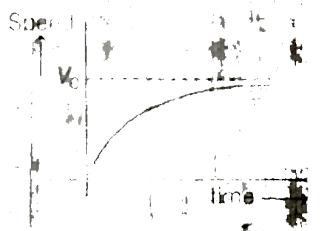

(S)

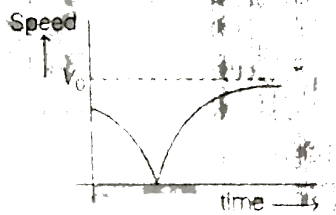

 [Watch Video Solution](#)

1. The reading of spring balance when a block is suspended from it in air, is 60 N. This reading is changed to 40 N when the block is immersed in water. The specific gravity of the block is



[Watch Video Solution](#)

2. The two wires shown in figure are made of the same material which has a breaking stress of  $8 \times 10^8 \text{ Nm}^{-2}$ . The area of cross section of the upper wire is  $0.006 \text{ cm}^2$  and that of the lower wire is  $0.003 \text{ cm}^2$ . The mass  $m_1 = 10 \text{ kg}$ ,  $m_2 = 20 \text{ kg}$  and the hanger is light. a. Find the maximum load that can be put on the hanger without breaking a wire.

Which wire will break first if the load is increased? b. Repeat

the above part  $m_1 = 10\text{kg}$  and  $m_2 = 36\text{kg}$ .

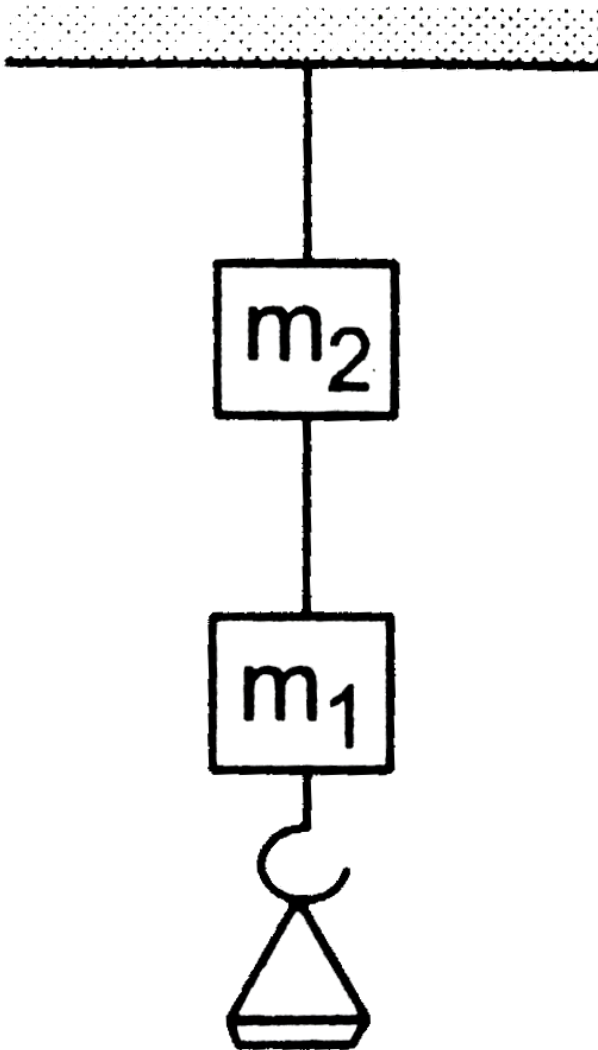

 Watch Video Solution

3. A wooden cube of side 10 cm and density  $0.8 \text{ gm/cm}^3$  is floating in water (density =  $1 \text{ gm/cm}^3$ ). A mass of  $(100x)$  gm is placed over the cube so that cube is completely immersed without wetting the mass. Find value of  $x$ .

 [Watch Video Solution](#)

4. A ball of mass 1 kg falls from a height of 5 m above the free surface of water. The relative density of the solid ball is  $s = \frac{2}{3}$ . The ball travels a distance of 2 m under water and becomes stationary. The work done by the resistive forces of water is  $(-10n)J$ . Find value of  $n$ .

 [Watch Video Solution](#)

5. A log of wood of mass 120 Kg floats in water. The weight that can be put on the raft to make it just sink, should be (density of wood =  $600\text{Kg}/\text{m}^3$ )

 [Watch Video Solution](#)

6. A large block of ice 10 cm thick with a vertical hole drilled through it is floating in a lake. The minimum length of the rope required to scoop out a bucket full of water through the hole is  $(0.2x)\text{m}$ . Find the value of  $x$ . Take density of ice =  $0.9\text{ g}/\text{cm}^3$

 [Watch Video Solution](#)

7. A cubical block 'A' of mass  $m_0 (= a^3 \rho = 3kg)$  of edge 'a' and density  $\rho$  floats in a liquid of density  $3\rho$ . The lower surface of the cube just touches the free end of massless spring of spring constant  $k (= a^2 \rho g)$  fixed at the bottom of the vessel. Another block 'B' of mass 'm' is kept over block 'A', so that it is completely immersed in liquid without wetting the block 'B'. Then find the value of m in kg.



[Watch Video Solution](#)

8. A solid uniform ball having volume  $V$  and density  $\rho$  floats at the interface of two unmixible liquids as shown in Fig. 7(CF).7. The densities of the upper and lower liquids are  $\rho_1$  and  $\rho_2$  respectively, such that  $\rho_1 < \rho < \rho_2$ . What fraction

of the volume of the ball will be in the lower liquid.

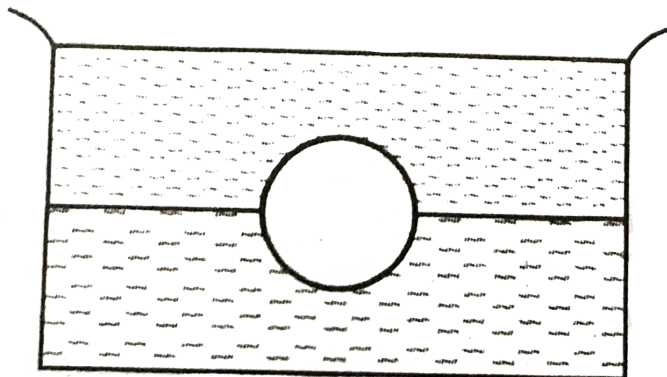

**Watch Video Solution**