



## PHYSICS

### BOOKS - DC PANDEY ENGLISH

#### Vectors

#### Solved Examples

1. In the shown fig . 5.12 (a) , (b) and (c) , find the angle between  $A$  and  $B$  .

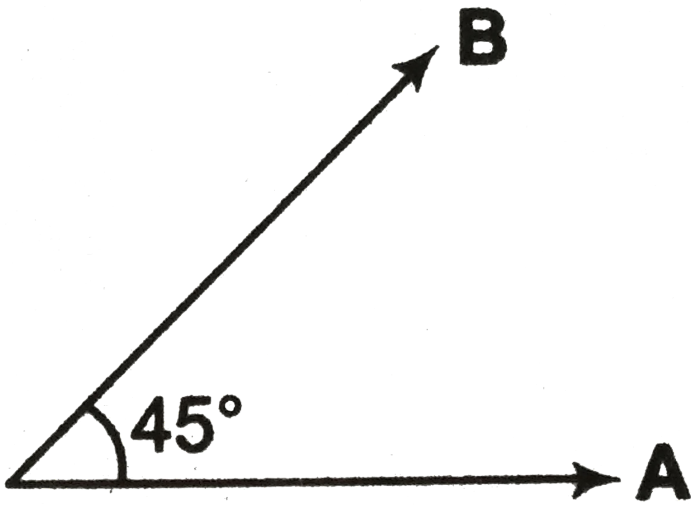

(a)

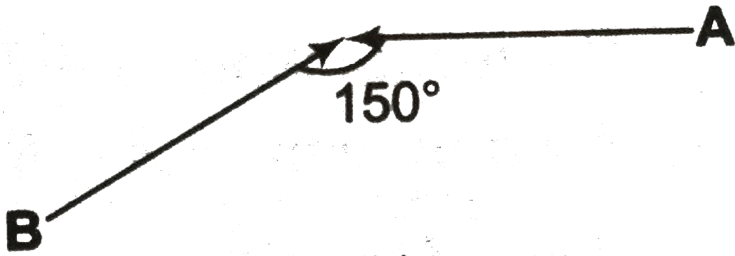

(b)

(b)

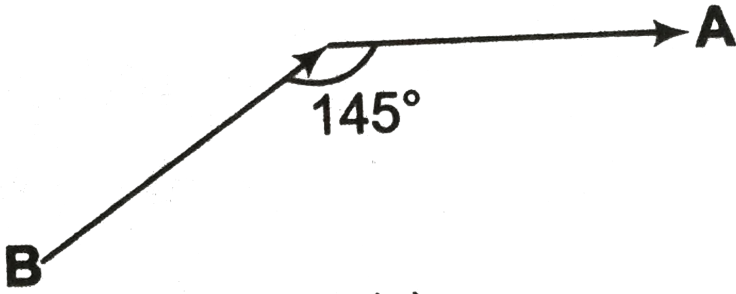

(c)



Watch Video Solution

2. What is the angle between  $a$  and  $-\frac{3}{2}a$ .



Watch Video Solution

3. Find  $A+B$  and  $A-B$  in the diagram shown in figure.

Given  $A=4$  units and  $B=3$  units.

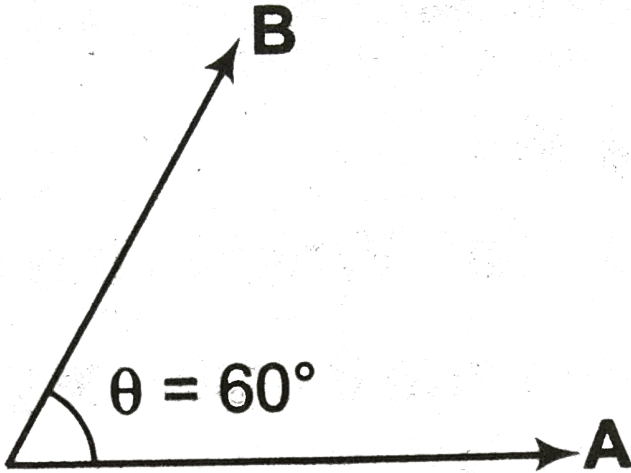

[Watch Video Solution](#)

4. A force  $F$  has magnitude of  $15N$ . Direction of  $F$  is at  $37^\circ$  from negative x-axis towards positive y-axis.

Represent  $F$  in terms of  $\hat{i}$  and  $\hat{j}$ .



[Watch Video Solution](#)

5. Find magnitude and direction of a vector,

$$A = (6\hat{i} - 8\hat{j}).$$



[Watch Video Solution](#)

6. Resolve a weight of 10N in two directions which are parallel and perpendicular to a slope inclined at  $30^\circ$  to the horizontal.



[Watch Video Solution](#)

7. Resolve horizontally and vertically a force  $f = 8 \text{ N}$  which makes an angle of  $45^\circ$  with the horizontal.

 [Watch Video Solution](#)

8. Obtain the magnitude of  $2A - 3B$  if

$$A = \hat{i} + \hat{j} - 2\hat{k} \text{ and } b = 2\hat{i} - \hat{j} + \hat{k}.$$

 [Watch Video Solution](#)

9. Work done by a force  $F$  on a body is  $W = F \cdot s$ , where  $s$  is the displacement of body. Given that under a force

$$F = (2\hat{i} + 3\hat{j} + 4\hat{k}) \text{ N a body is displaced from}$$

position vector  $r_1 = (2\hat{i} + 3\hat{j} + \hat{k})$  m to the position vector  $r_2 = (\hat{i} + \hat{j} + \hat{k})$  m. Find the work done by this force.

 [Watch Video Solution](#)

10. Find the angle between two vectors  $A = 2\hat{i} + \hat{j} - \hat{k}$  and  $B = \hat{i} - \hat{k}$ .

 [Watch Video Solution](#)

11. Prove that the vectors  $A = 2\hat{i} - 3\hat{j} + \hat{k}$  and  $B = \hat{i} + \hat{j} + \hat{k}$  are mutually perpendicular.

 [Watch Video Solution](#)

12. Show that the vector  $A = (\hat{i}) - (\hat{j}) + 2\hat{k}$  is parallel to a vector  $B = 3\hat{i} - 3\hat{j} + 6\hat{k}$ .



Watch Video Solution

13. Let a force  $F$  be acting on a body free to rotate about a point  $O$  and let  $r$  the position vector of any point  $P$  on the line of action of the force. Then torque ( $\tau$ ) of this force about point  $O$  is defined as  $\tau = r \times F$

Given,

$F = (2\hat{i} + 3\hat{j} - \hat{k})N$  and  $r = (\hat{i} - \hat{j} + 6\hat{k})m$  Find

the torque of this force.



Watch Video Solution



 Watch Video Solution

14. Find component of vector  $A + B$  along (i) x-axis, (ii) C.

Given  $A = \hat{i} - 2\hat{j}$ ,  $B = 2\hat{i} + 3\hat{k}$  and  $C = \hat{i} + \hat{j}$ .



Watch Video Solution

15. Find the angle that the vector  $A = 2\hat{i} + 3\hat{j} - \hat{k}$  makes with y-axis.



Watch Video Solution

16. If a and b are the vectors AB and BC determined by the adjacent sides of a regular hexagon. What are the

vectors determined by the other sides taken in order?



Watch Video Solution

17. if  $a \times b = b \times c \neq 0$  with  $a \neq -c$  then show that  $a+c = kb$ , where  $k$  is scalar.



Watch Video Solution

18. if  $A = 2\hat{i} - 3\hat{j} + 7\hat{k}$ ,  $B = \hat{i} + 2\hat{j}$  and  $C = \hat{j} - \hat{k}$ .

Find  $A(B \times C)$



Watch Video Solution

19. Find the resultant of the three vectors  $\vec{OA}$ ,  $\vec{OB}$  and  $\vec{OC}$  shown in figure. Radius of the circle is R.

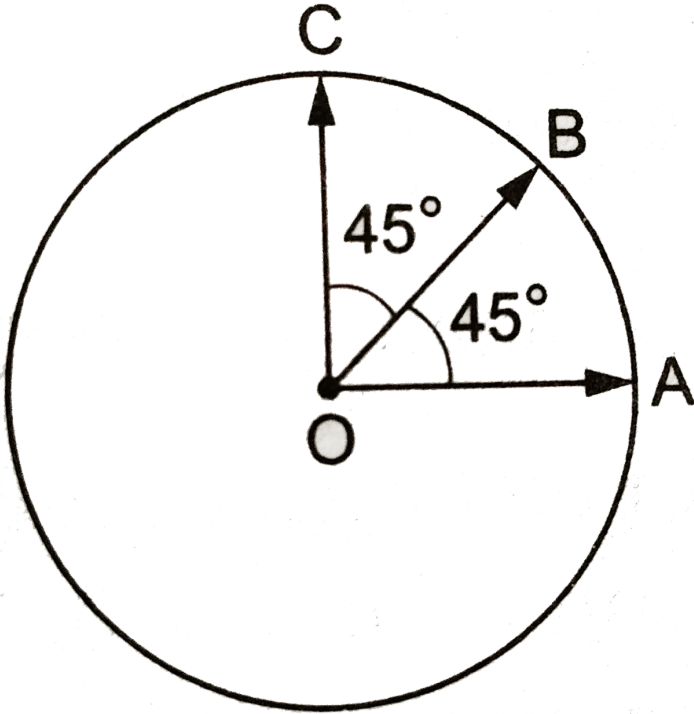

Watch Video Solution

20. Prove that  $|a \times b|^2 = a^2b^2 - (a \cdot b)^2$



Watch Video Solution

21. Show that the vectors

$$a = 3\hat{i} - 2\hat{j} + \hat{k}, b = \hat{i} - 3\hat{j} + 5\hat{k} \quad \text{and}$$

$$c = 2\hat{j} + \hat{j} - 4\hat{k} \text{ form a right angled triangle.}$$



Watch Video Solution

22. Let A, B and C be the unit vectors . Suppose that

$A \cdot B = A \cdot C = 0$  and the angle between B and C is  $\frac{\pi}{6}$  then

prove that  $A = \pm 2(B \times C)$

 [Watch Video Solution](#)

23. A particle moves on a given straight line with a constant speed  $v$ . At a certain time it is at a point  $P$  on its straight line path.  $O$  is a fixed point. Show that  $\vec{OP} \times \vec{v}$  is independent of the position  $P$ ?

 [Watch Video Solution](#)

24. Prove that the mid-point of the hypotenuse of right angled triangle is equidistant from its vertices.

 [Watch Video Solution](#)

## Exercise 5 1

1. What is the angle between  $2a$  and  $4a$ ?



[Watch Video Solution](#)

2. What is the angle between  $3a$  and  $-5a$ ? What is the ratio of magnitude of two vectors?



[Watch Video Solution](#)

3. Two vectors have magnitudes 6 and 8 units, respectively. Find the magnitude of the resultant vector

if the angle between vectors is (a)  $60^\circ$  (b)  $90^\circ$  and ( c )  $120^\circ$  .



[Watch Video Solution](#)

4. Two vectors A and B have magnitudes 6 units and 8 units respectively. Find  $|A-B|$ , if the angle between two vectors is .(a)  $0^\circ$  (b)  $180^\circ$  (c)  $180^\circ$  (d)  $120^\circ$  .



[Watch Video Solution](#)

5. For what angle between A and B,  
 $|A + B| = |A - B|$  .



[Watch Video Solution](#)

## Exercise 5 2

1. Find magnitude and direction cosines of the vector,

$$A = (3\hat{i} - 4\hat{j} + 5\hat{k}).$$



[Watch Video Solution](#)

2. Resolve a force  $F = 10\text{N}$  along  $x$  and  $y$ -axes. Where this force vector in making an angle of  $60^\circ$  from negative  $x$ -axis towards negative  $y$ -axis?



[Watch Video Solution](#)



3. Find magnitude of  $A - 2B + 3C$ , where,

$$A = 2\hat{i} + 3\hat{j}, B = \hat{i} + \hat{j} \text{ and } C = \hat{k}.$$



[Watch Video Solution](#)

4. Find angle between  $A$  and  $B$  where, (a)

$$A = 2\hat{i} \text{ and } B = -6\hat{i} \quad (\text{b}) \quad A = 6\hat{j} \text{ and } B = -2\hat{k} \quad (\text{c})$$

$$A = (2\hat{i} + 3\hat{j}) \text{ and } B = 4\hat{k} \quad (\text{d}) \quad A = 4\hat{i} \text{ and}$$

$$B = (-3\hat{i} + 3\hat{j}).$$



[Watch Video Solution](#)

### Exercise 5.3

1. Cross product of two parallel or antiparallel vectors is a null vector. Is this statement true or false?

 [Watch Video Solution](#)

2. Find the values of . (a)  $(4\hat{j}) \times (-6\hat{k})$  (b)  $(3\hat{j}) \cdot (-4\hat{j})$  (c)  $(2\hat{i}) - (-4\hat{k})$  .

 [Watch Video Solution](#)

3. Two vectors A and B have magnitudes 2 units and 4 units respectively. Find A. B is angle between these two vectors is (a)  $0^\circ$  (b)  $60^\circ$  (c)  $90^\circ$  (d)  $120^\circ$  .

 [Watch Video Solution](#)

4. Find  $(2A) \times (-3B)$ , if  $A = 2\hat{i} - \hat{j}$  and  $B = (\hat{j} + \hat{k})$



Watch Video Solution

Single Correct

1. which one of the following is a scalar quantity?

A. Dipole moment

B. Electric field

C. Acceleration

D. work

**Answer: D**



**Watch Video Solution**

2. Which one of the following is not the vector quantity?

A. Torque

B. Displacement

C. Velocity

D. Speed

**Answer: D**



**Watch Video Solution**

**3. Which one is a vector quantity?**

A. Time

B. Temperature

C. Magnetic flux

D. Magnetic field intensity

**Answer: D**



**Watch Video Solution**

4. Minimum number of vectors of unequal magnitudes which can give zero resultant are

A. two

B. three

C. four

D. more than four

**Answer: B**



[Watch Video Solution](#)

5. which one of the following statement is false ?

- A. A vector cannot be displaced from one point to another point
- B. Distance is a scalar quantity but displacement is a vector quantity
- C. Momentum force and torque are vector quantities
- D. Mass, speed and energy are scalar quantities

**Answer: A**



**Watch Video Solution**

6. what is the dot product of two vectors of magnitudes 3 and 5,if angle between them is  $60^\circ$  ?

A. 5.2

B. 7.5

C. 8.4

D. 8.6

**Answer: B**



**Watch Video Solution**



7. The forces, which meet at one point but their line of action do not lie in one plane, are called

- A. non coplanar non concurrent forces
- B. non coplanar concurrent forces
- C. coplanar concurrent forces
- D. coplanar non-concurrent forces

**Answer: B**



**Watch Video Solution**

8. A vector  $\vec{A}$  points vertically upward and  $\vec{B}$  points towards north. The vector product  $\vec{A} \times \vec{B}$  is

- A. along west
- B. along east
- C. zero
- D. vertically downward

**Answer: A**



**Watch Video Solution**

9. The magnitude of the vectors product of two vectors

$\left| \vec{A} \right|$  and  $\left| \vec{B} \right|$  may be

- A. greater than AB
- B. equal to AB
- C. less than AB
- D. equal to zero

**Answer: B::C::D**



**Watch Video Solution**

10. A force  $(3\hat{i} + 4\hat{j})$  newton acts on a body and displaces it by  $(3\hat{i} + 4\hat{j})$  metre. The work done by the force is

A. 5 J

B. 25 J

C. 10 J

D. 30 J

**Answer: B**



**Watch Video Solution**

11. The torque of force  $F = (2\hat{i} - 3\hat{j} + 4\hat{k})$  newton acting at the point  $r = (3\hat{i} + 2\hat{j} + 3\hat{k})$  metre about origin is (in N-m)

A.  $6\hat{i} - 6\hat{j} + 12\hat{k}$

B.  $17\hat{i} - 6\hat{j} - 13\hat{k}$

C.  $-6\hat{i} + 6\hat{j} - 12\hat{k}$

D.  $-17\hat{i} + 6\hat{j} + 13\hat{k}$

**Answer: B**



**Watch Video Solution**

12. If a unit vector is represented by  $0.5\hat{i} + 0.8\hat{j} + c\hat{k}$

the value of  $c$  is

A. 1

B.  $\sqrt{0.11}$

C.  $\sqrt{0.01}$

D. 0.39

**Answer: B**



**Watch Video Solution**

13. Two vectors of equal magnitudes have a resultant equal to either of them, then the angle between them will be

A.  $30^\circ$

B.  $120^\circ$

C.  $60^\circ$

D.  $150^\circ$

**Answer: B**



**Watch Video Solution**

14. If a vector  $2\hat{i} + 3\hat{j} + 8\hat{k}$  is perpendicular to the vector  $4\hat{i} - 4\hat{j} + \alpha\hat{k}$ , then the value of  $\alpha$  is

A. -1

B.  $\frac{1}{2}$

C.  $-\frac{1}{2}$

D. 1

**Answer: B**



**Watch Video Solution**



15. The angle between the two vectors

$$A = 3\hat{i} + 4\hat{j} + 5\hat{k} \text{ and } B = 3\hat{i} + 4\hat{j} - 5\hat{k} \text{ is}$$

A.  $60^\circ$

B.  $45^\circ$

C.  $90^\circ$

D.  $30^\circ$

**Answer: C**



**Watch Video Solution**

**16.** Maximum and minimum values of the resultant of two forces acting at a point are 7 N and 3 N respectively . The smaller force will be equal to

A. 5 N

B. 4 N

C. 2 N

D. 1 N

**Answer: C**



**Watch Video Solution**

17. if the vectors  $P = \alpha\hat{i} + \alpha\hat{j} + 3\hat{k}$  and  $Q = \alpha\hat{i} - 2\hat{j} - \hat{k}$  are perpendicular to each other, then the positive value of  $\alpha$  is

A. 0 (zero)

B. 1

C. 2

D. 3

**Answer: D**



**Watch Video Solution**

18. The (x,y,z) co -ordinates of two points A and B are give respectively as (0,3,- 1) and (-2,6,4) The displacement vector from A to B is given by

A.  $-2\hat{i} + 6\hat{j} + 4\hat{k}$

B.  $-2\hat{i} + 3\hat{j} + 3\hat{k}$

C.  $-2\hat{i} + 3\hat{j} + 5\hat{k}$

D.  $2\hat{i} - 3\hat{j} - 5\hat{k}$

**Answer: C**



**Watch Video Solution**

19. A vector is not changed if

- A. it is rotated through an arbitrary angle
- B. it is multiplied by an arbitrary scalar
- C. it is cross multiplied by a unit vector
- D. it is displaced parallel to itself

**Answer: D**



**Watch Video Solution**

20. Which of the sets given below may represent the magnitudes of three vectors adding to zero?

A. 2,4,8

B. 4,8,16

C. 1,2,1

D. 0.5, 1.2

**Answer: C**



**Watch Video Solution**

21. The resultant of  $\vec{A}$  and  $\vec{B}$  makes an angle  $\alpha$  with  $\vec{A}$  and  $\beta$  and  $\vec{B}$ ,

A.  $\alpha$  is always less than  $\beta$

B.  $\alpha < \beta$  if  $A < B$

C.  $\alpha < \beta$  if  $A > B$

D.  $\alpha < \beta$  if  $A = B$

**Answer: C**



**Watch Video Solution**

22. The angles which the vector  $A = 3\hat{i} + 6\hat{j} + 2\hat{k}$  makes with the co-ordinate axes are

A.  $\cos^{-1} \cdot \frac{3}{7}$ ,  $\cos^{-1} \cdot \frac{6}{7}$  and  $\cos^{-1} \cdot \frac{2}{7}$

B.  $\cos^{-1} \cdot \frac{4}{7}$ ,  $\cos^{-1} \cdot \frac{5}{7}$  and  $\cos^{-1} \cdot \frac{3}{7}$

C.  $\cos^{-1} \cdot \frac{3}{7}$ ,  $\cos^{-1} \cdot \frac{4}{7}$  and  $\cos^{-1} \cdot \frac{1}{7}$

D. None of these

**Answer: A**



**Watch Video Solution**

**23.** Unit vector parallel to the resultant of vectors

$A = 4\hat{j} - 3\hat{j}$  and  $B = 8\hat{j} + 8\hat{j}$  will be

A.  $\frac{24\hat{i} + 5\hat{j}}{13}$

B.  $\frac{12\hat{i} + 5\hat{j}}{13}$

C.  $\frac{6\hat{i} + 5\hat{j}}{13}$

D. None of these

**Answer: B**



**Watch Video Solution**



24. The component of vector  $A = 2\hat{i} + 3\hat{j}$  along the vector  $\hat{i} + \hat{j}$  is

A.  $\frac{5}{\sqrt{2}}$

B.  $10\sqrt{2}$

C.  $5\sqrt{2}$

D. 5

**Answer: A**



**Watch Video Solution**

25. Two vectors  $A$  and  $B$  are such that  $A + B = C$  and  $A^2 + B^2 = C^2$ . If  $\theta$  is the angle between positive direction of  $A$  and  $B$ , then the correct statement is

A.  $\theta = \pi$

B.  $\theta = \frac{2\pi}{3}$

C.  $\theta = 0$

D.  $\theta = \frac{\pi}{2}$

**Answer: D**



**Watch Video Solution**

26. If  $|A \times B| = \sqrt{3}A \cdot B$ , then the value of  $|A+B|$  is

A.  $(A^2 + B^2 + AB)^{1/2}$

B.  $\left(A^2 + B^2 + \frac{AB}{\sqrt{3}}\right)^{1/2}$

C.  $(A + B)$

D.  $(A^2 + B^2 + \sqrt{3}AB)^{1/2}$

**Answer: A**



**Watch Video Solution**

27. If the angle between the vectors A and B is  $\theta$ , the value of the product  $(B \times A) \cdot A$  is equal to

A.  $BA^2 \cos \theta$

B.  $BA^2 \sin \theta$

C.  $BA^2 \sin \theta \cos \theta$

D. zero

**Answer: D**



**Watch Video Solution**

28. Given that  $P = 12$ ,  $Q = 5$  and  $R = 13$  also  $P+Q=R$ , then the angle between  $P$  and  $Q$  will be

A.  $\pi$

B.  $\frac{\pi}{2}$

C. zero

D.  $\frac{\pi}{4}$

**Answer: B**



**Watch Video Solution**

**29.** Given that  $P+Q+R= 0$ . Two out of the three vectors are equal in magnitude. The magnitude fo the third vector is  $s\sqrt{2}$  times that of the other two. Which of the following can be the angles between these vectors?

A.  $90^\circ, 135^\circ, 135^\circ$

B.  $45^\circ, 45^\circ, 90^\circ$

C.  $30^\circ$ ,  $60^\circ$ ,  $90^\circ$

D.  $45^\circ$ ,  $90^\circ$ ,  $135^\circ$

**Answer: A**



**Watch Video Solution**

**30.** The angles between  $P+Q$  and  $P-Q$  will be

A.  $90^\circ$

B. between  $0^\circ$  and  $180^\circ$

C.  $180^\circ$  only

D. None of these

**Answer: B**



**Watch Video Solution**

31. The value of  $n$  so that vectors  $2\hat{i} + 3\hat{j} - 2\hat{k}$ ,  $5\hat{i} + n\hat{j} + \hat{k}$  and  $-\hat{i} + 2\hat{j} + 3\hat{k}$  may be coplanar will be

A. 18

B. 28

C. 9

D. 36

**Answer: A**



Watch Video Solution

32. If  $a$  and  $b$  are two vectors, then the value of  $(a + b) \times (a - b)$  is

A.  $2(b \times a)$

B.  $-2(b \times a)$

C.  $b \times a$

D.  $a \times b$

**Answer: A**



Watch Video Solution



33. The resultant of two forces  $3P$  and  $2P$  is  $R$ . If the first force is doubled then resultant is also doubled. The angle between the two forces is

A.  $60^\circ$

B.  $120^\circ$

C.  $30^\circ$

D.  $135^\circ$

**Answer: B**



**Watch Video Solution**

**34.** The resultant of two forces, one double the other in magnitude is perpendicular to the smaller of the two forces. The angle between the two forces is

A.  $120^\circ$

B.  $60^\circ$

C.  $90^\circ$

D.  $150^\circ$

**Answer: A**



**Watch Video Solution**

35. Three vectors satisfy the relation  $A \cdot B = 0$  and  $A \cdot C = 0$

then  $A$  is parallel to

A.  $C$

B.  $B$

C.  $B \times C$

D.  $B \cdot C$

**Answer: C**



**Watch Video Solution**

**36.** The sum of two forces at a point is 16N. if their resultant is normal to the smaller force and has a magnitude of 8N, then two forces are

A. 6N, 10N

B. 8N, 8N

C. 4N, 12N

D. 2N, 14N

**Answer: A**



**Watch Video Solution**

37. The sum of two vectors A and B is at right angles to their difference. Then

A.  $A=B$

B.  $A=2B$

C.  $B=2A$

D. A and B have the same direction

**Answer: A**



**Watch Video Solution**

38. Let  $\vec{C} = \vec{A} + \vec{B}$  then

A.  $|C|$  is always greater than  $|A|$

B. it is possible to have  $|C| < |A|$  and  $|C| < |B|$

C.  $C$  is always equal to  $A+B$

D.  $C$  is never equal to  $A+B$

**Answer: B**



**Watch Video Solution**

**39.** Let the angle between two nonzero vector

$\vec{A}$  and  $\vec{B}$  is  $120^\circ$  and its resultant be  $\vec{C}$ .

A.  $C$  must be equal to  $|A-B|$

B.  $C$  must be less than  $|A-B|$

C. C must be greater than  $|A-B|$

D. C may be equal to  $|A-B|$

**Answer: C**



[Watch Video Solution](#)

**Subjective**

1. If  $a = 2\hat{i} + 3\hat{j} + 4\hat{k}$  and  $b = 4\hat{i} + 3\hat{j} + 2\hat{k}$ , find the angle between a and b.



[Watch Video Solution](#)

2. The vectors  $\vec{A}$  has a magnitude of 5 unit  $\vec{B}$  has a magnitude of 6 unit and the cross product of  $\vec{A}$  and  $\vec{B}$  has a magnitude of 15 unit. Find the angle between  $\vec{A}$  and  $\vec{B}$ .



[Watch Video Solution](#)

3. Suppose  $\vec{a}$  is a vector of magnitude 4.5 unit due north. What is the vector (a)  $3\vec{a}$  (b)  $-4\vec{a}$ ?



[Watch Video Solution](#)



4. Two vectors have magnitudes 3 unit and 4 unit respectively. What should be the angel between them if the magnitude of the resultant is (a). 1 unit (b). 5 unit and (c). 7 unit.



[Watch Video Solution](#)

5. The work done by a force  $\vec{F}$  during a displacement  $\vec{r}$  is given by  $\vec{F} \cdot \vec{r}$ . Suppose a force of 12 N acts on a particle in vertically upward direction and the particle is displaced through 2.0 m in vertically downward direction. Find the work done by the force during this displacement.



[Watch Video Solution](#)

 Watch Video Solution

6. If  $\vec{A}$ ,  $\vec{B}$ ,  $\vec{C}$  are mutually perpendicular show that  $\vec{C} \times (\vec{A} \times \vec{B}) = 0$ . Is the converse true?



Watch Video Solution

7. Prove that  $\vec{A} \cdot (\vec{A} \times \vec{B}) = 0$



Watch Video Solution

8. Find the resultant of the three vectors shown in figure (2W1).

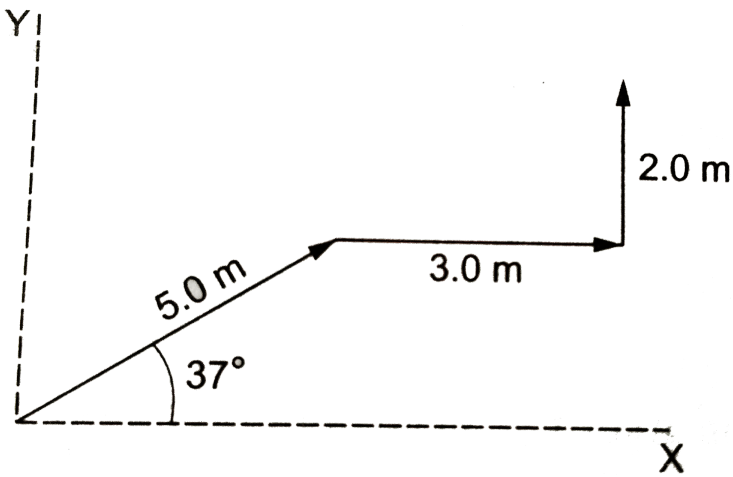

Watch Video Solution

9. Given an example for which

$$\vec{A} \cdot \vec{B} = \vec{C} \cdot \vec{B} \text{ but } \vec{A} \neq \vec{C}.$$



Watch Video Solution

10. Obtain the angle between  $A+B$  and  $A-B$  if

$$A = 2\hat{i} + 3\hat{j} \text{ and } B = \hat{i} - 2\hat{j}.$$



[Watch Video Solution](#)

11. Deduce the condition for the vectors

$$2\hat{i} + 3\hat{j} - 4\hat{k} \text{ and } 3\hat{i} - \alpha\hat{j} + b\hat{k} \text{ to be parallel.}$$



[Watch Video Solution](#)

12. Find the area of the parallelogram whose sides are

$$\text{represented by } 2\hat{i} + 4\hat{j} - 6\hat{k} \text{ and } \hat{i} + 2\hat{k}.$$



[Watch Video Solution](#)

13. If vectors  $A$  and  $B$  be respectively equal to  $3\hat{i} - 4\hat{j} + 5\hat{k}$  and  $2\hat{i} + 3\hat{j} - 4\hat{k}$ . Find the unit vector parallel to  $A + B$



Watch Video Solution

14. if  $A = 2\hat{i} - 3\hat{j} + 7\hat{k}$ ,  $B = \hat{i} + 2\hat{j}$  and  $C = \hat{j} - \hat{k}$ .

Find  $A(B \times C)$



Watch Video Solution

**15.** The x and y-components of vector A are 4 m and 6 m respectively. The x and y-components of vector A + B are 10 m and 9 m respectively. Calculate for the vector B the following:

- (a) its x and y-components
- (b) its length
- (c) the angle it makes with x-axis.



**Watch Video Solution**

**16.** Three vectors which are coplanar with respect to a certain rectangular co-ordinate system are given by

$$a = 4\hat{i} - \hat{j}, b = -3\hat{i} + 2\hat{j} \text{ and } c = -3\hat{j}$$

Find

(a)  $a + b + c$

(b)  $a + b - c$

(c) Find the angle between  $a + b + c$  and  $a + b - c$



[Watch Video Solution](#)

17. Let  $\vec{A}$  and  $\vec{B}$  be the two vectors of magnitude 10 unit each. If they are inclined to the X-axis at angles  $30^\circ$  and  $60^\circ$  respectively, find the resultant.



[Watch Video Solution](#)

18. The resultant of vectors  $\vec{OA}$  and  $\vec{OB}$  is perpendicular to  $\vec{OA}$ . Find the angle AOB.

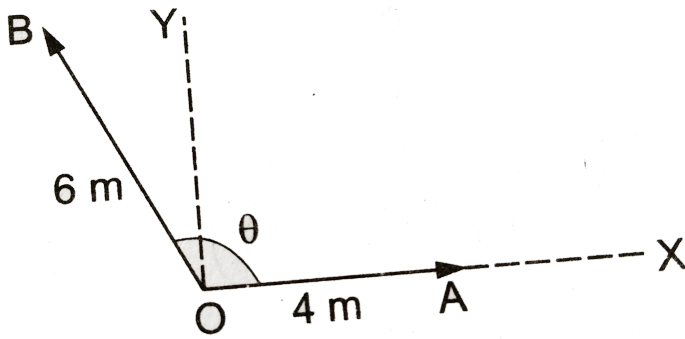

[▶ Watch Video Solution](#)

19. Find the components of a vector  $A = 2\hat{i} + 3\hat{j}$  along the directions of  $\hat{i} + \hat{j}$  and  $\hat{i} - \hat{j}$ .

[▶ Watch Video Solution](#)

20. If two vectors are  $A = 2\hat{i} + \hat{j} - \hat{k}$  and  $B = \hat{j} - 4\hat{k}$ . By calculation,



prove  $\mathbf{A} \times \mathbf{B}$  is perpendicular to both  $\mathbf{A}$  and  $\mathbf{B}$ .



[Watch Video Solution](#)

21. The resultant of two vector  $\mathbf{A}$  and  $\mathbf{B}$  is at right angles to  $\mathbf{A}$  and its magnitude is half of  $\mathbf{B}$ . Find the angle between  $\mathbf{A}$  and  $\mathbf{B}$ .



[Watch Video Solution](#)

22. Four forces of magnitude  $P$ ,  $2P$ ,  $3P$  and  $4P$  act along the four sides of a square  $ABCD$  in cyclic order. Use the vector method to find the magnitude of resultant force.

 [Watch Video Solution](#)

23. If  $P + Q = R$  and  $P - Q = S$ , prove that

$$R^2 + S^2 = 2(P^2 + Q^2)$$

 [Watch Video Solution](#)

24. In an  $\triangle ABC$  as shown in Fig. 2. (2) .71 (a) prove

that 
$$\frac{a}{\sin A} = \frac{b}{\sin B} = \frac{c}{\sin C}.$$

 [Watch Video Solution](#)

Example

1. check Wether the vector  $\left( \frac{\hat{i}}{\sqrt{2}} + \frac{\hat{j}}{\sqrt{2}} \right)$  is a unit vector or not .

 [Watch Video Solution](#)

2. Find the unit vector of  $4\hat{i} - 3\hat{j} + \hat{k}$ .

 [Watch Video Solution](#)

3. If vector  $\hat{i} - 3\hat{j} + 5\hat{k}$  and  $\hat{i} - 3\hat{j} - a\hat{k}$  are equal vector then find the value of a.

 [Watch Video Solution](#)

4. If  $\vec{A} = 3\hat{i} + 4\hat{j}$  and  $\vec{B} = 7\hat{i} + 24\hat{j}$ , find a vector having the same magnitude as  $\vec{B}$  and parallel to  $\vec{A}$ .



[Watch Video Solution](#)

5. Two forces whose magnitudes are in the ratio 3:5 give a resultant of 28N. If the angle of their inclination is  $60^\circ$ , find the magnitude of each force.



[Watch Video Solution](#)

6. A boy walks 4m east and then 3m south. Find the displacement of the boy.

A. 7

B. 1

C. 5

D. 12

**Answer: 3**



[Watch Video Solution](#)

7. If  $A=B+C$  have scalar magnitudes of 5,4,3 units respectively , then find the angle between A and C.



[Watch Video Solution](#)

8. Find the sum of vector A and B as shown in the figure ,also find the direction of sum vector. Given  $A=4$ unit and  $B=3$  unit .

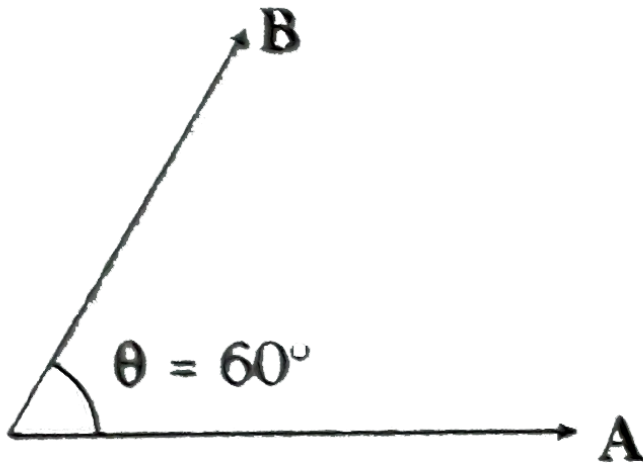

[Watch Video Solution](#)

9. Two equal vector have a resultant equal to either of them, then the angle between them will be:



Watch Video Solution

10. Find the resultant of three vectors shown in the figure.

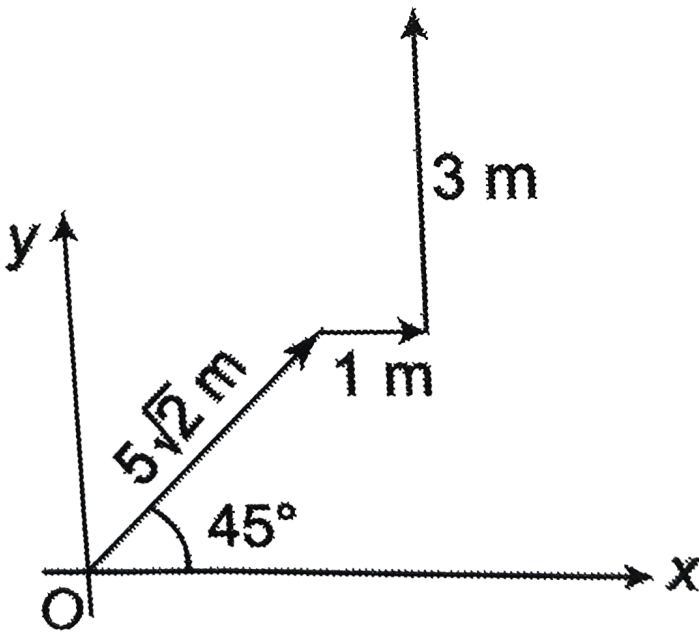

Watch Video Solution

11. Find the subtraction of vector A and B as shown in the figure , also find the direction of subtraction vector ,Given A=4 unit and b=3 unit .

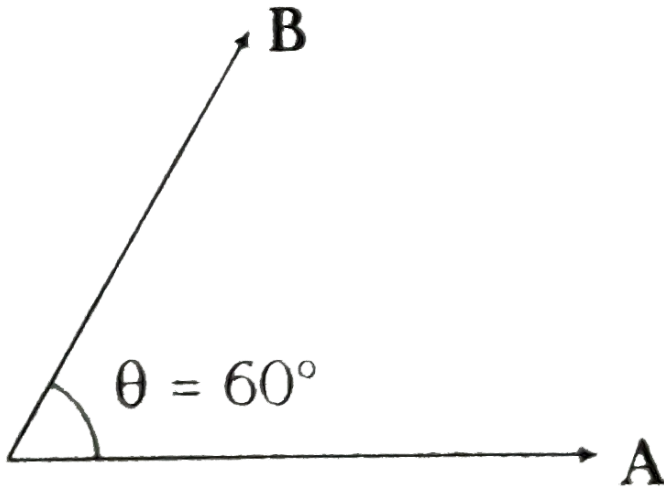

[Watch Video Solution](#)

12. Obtain the magnitude of  $2A - 3B$  if

$$A = \hat{i} + \hat{j} - 2\hat{k} \text{ and } B = 2\hat{i} - \hat{j} + \hat{k} .$$





[Watch Video Solution](#)

13. If  $a$  and  $b$  are the vectors  $AB$  and  $BC$  determined by the adjacent sides of a regular hexagon. What are the vectors determined by the other sides taken in order?



[Watch Video Solution](#)

14. The initial and final position vector for a particle are  $(-3m)\hat{i} + (2m)\hat{j} + (8m)\hat{k}$  and  $(9m)\hat{i} + (2m)\hat{j} + (-8m)\hat{k}$  respectively, find the displacement of the particle.



[Watch Video Solution](#)

15. If  $|\vec{P} + \vec{Q}| = |\vec{P} - \vec{Q}|$ , find the angle between  $\vec{P}$  and  $\vec{Q}$ .

 [Watch Video Solution](#)

16. A vector is given by  $\vec{A} = 3\hat{i} + 4\hat{j} + 5\hat{k}$ . Find the magnitude of  $\vec{A}$ , unit vector along  $\vec{A}$  and angles made by  $\vec{A}$  with coordinate axes.

 [Watch Video Solution](#)

17. Resolve a weight of 10N in two directions which are parallel and perpendicular to a slope inclined at  $30^\circ$  to

the horizontal.



Watch Video Solution

**18.** Resolve horizontally and vertically a force  $F = 8N$  which makes an angle of  $45^\circ$  with the horizontal.



Watch Video Solution

**19.** Find the resultant of the following forces.

$$\left[ \sin 37^\circ = \frac{3}{5}, \cos 37^\circ = \frac{4}{5}, \sin 53^\circ = \frac{4}{5}, \cos 53^\circ = \frac{3}{5} \right]$$

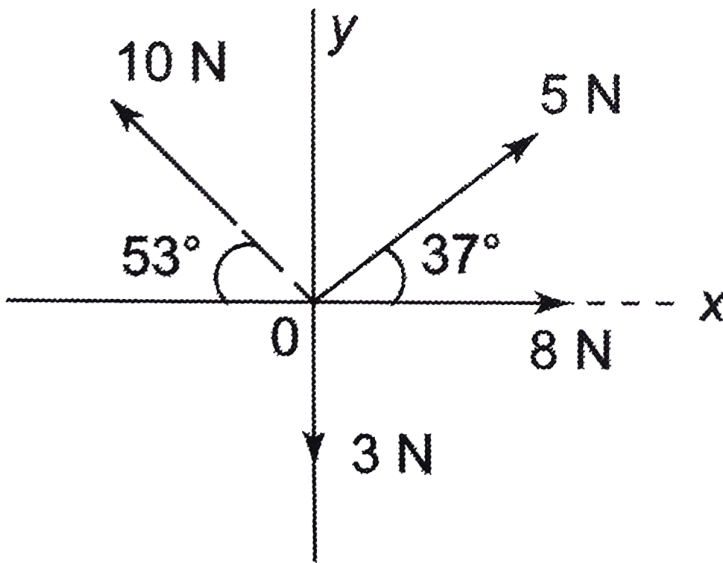

[▶ Watch Video Solution](#)

20. Find the angle that the vector  $A = 2\hat{i} + 3\hat{j} - \hat{k}$  makes with y-axis.

[▶ Watch Video Solution](#)

21. If a particle moves from the point  $A(1, 2, 3)$  to the point  $B(4, 6, 9)$ , its displacement vector be



[Watch Video Solution](#)

22. Prove that the quadrilateral formed by joining the mid-points of the pairs of consecutive sides of a quadrilateral is a parallelogram.



[Watch Video Solution](#)

23. Find component of vector  $A + B$  along (i) x-axis, (ii)  $C$ .

Given  $A = \hat{i} - 2\hat{j}$ ,  $B = 2\hat{i} + 3\hat{k}$  and  $C = \hat{i} + \hat{j}$ .

 [Watch Video Solution](#)

24. Work done by a force  $F$  on a body is  $W = F \cdot s$ , where  $s$  is the displacement of body. Given that under a force  $F = (2\hat{i} + 3\hat{j} + 4\hat{k})$  N a body is displaced from position vector  $r_1 = (2\hat{i} + 3\hat{j} + \hat{k})$  m to the position vector  $r_2 = (\hat{i} + \hat{j} + \hat{k})$  m. Find the work done by this force.

 [Watch Video Solution](#)

25. Find the angle between two vector  $A = 2\hat{i} + \hat{j} - \hat{k}$  and  $B = \hat{i} - \hat{k}$ .

 [Watch Video Solution](#)

26. Prove that the vectors  $A = 2\hat{i} - 3\hat{j} + \hat{k}$  and  $B = \hat{i} + \hat{j} + \hat{k}$  are mutually perpendicular.

[Watch Video Solution](#)

27. Find the (i) Scalar component and (ii) vector component of  $A = 3\hat{i} + 4\hat{j} + 5\hat{k}$  on  $B = \hat{i} + \hat{j} + \hat{k}$ .

[Watch Video Solution](#)

28. Show that the vectors

$$a = 3\hat{i} - 2\hat{j} + \hat{k}, b = \hat{i} - 3\hat{j} + 5\hat{k} \quad \text{and}$$

$$c = 2\hat{i} + \hat{j} - 4\hat{k} \text{ form a right angled triangle.}$$



Watch Video Solution

29. Prove that the mid-point of the hypotenuse of right angled triangle is equidistant from its vertices.



Watch Video Solution

30. Find the projection of

$$\vec{a} = 2\hat{i} - \hat{j} + \hat{k} \text{ and } \vec{b} = \hat{i} - 2\hat{j} + \hat{k}.$$





Watch Video Solution

**31.** Let a force  $F$  be acting on a body free to rotate about a point  $O$  and let  $r$  the position vector of any point  $P$  on the line of action of the force. Then torque ( $\tau$ ) of this force about point  $O$  is defined as  $\tau = r \times F$

Given,

$$F = (2\hat{i} + 3\hat{j} - \hat{k})N \text{ and } r = (\hat{i} - \hat{j} + 6\hat{k})m \text{ Find}$$

the torque of this force.



Watch Video Solution

**32.** Find a unit vector  $\hat{C} = A \times B$  is a vector perpendicular to both  $A$  and  $B$  Hence, a unit vector  $\hat{n}$

perpendicular to A and B can be Written as

$$\hat{n} = \frac{C}{|A \times B|} = \frac{A \times B}{|A \times B|}$$

$$\begin{aligned} \text{Here, } A \times B &= \begin{vmatrix} \hat{i} & \hat{j} & \hat{k} \\ 2 & 3 & 1 \\ 1 & -1 & 1 \end{vmatrix} \\ &= \hat{i}(3 + 1) + \hat{j}(1 - 2) + \hat{k}(-2 - 3) \\ &= 4\hat{i} - \hat{j} - 5\hat{k} \end{aligned}$$

$$\text{Further, } |A \times B| = \sqrt{(4)^2 + (-1)^2 + (-5)^2} = \sqrt{42}$$

$$\therefore \text{ the desired unit vector is } \hat{n} = \frac{A \times B}{|A \times B|}$$

$$\text{or } \hat{n} = \frac{1}{\sqrt{42}} (4\hat{i} - \hat{j} + 5\hat{k})$$



Watch Video Solution

33. Show that the vector  $A = (\hat{i}) - (\hat{j}) + 2\hat{k}$  is parallel to a vector  $B = 3\hat{i} - 3\hat{j} + 6\hat{k}$ .



Watch Video Solution

34. Prove that  $|a \times b|^2 = a^2b^2 - (a \cdot b)^2$



Watch Video Solution

35. A particle moves on a given straight line with a constant speed  $v$ . At a certain time it is at a point  $P$  on its straight line path.  $O$  is a fixed point. Show that  $\vec{OP} \times \vec{v}$  is independent of the position  $P$ ?



Watch Video Solution

36. if  $a \times b = b \times c \neq 0$  with  $a \neq -c$  then show that  $a+c = kb$ , where  $k$  is scalar.

 [Watch Video Solution](#)

37. Let  $A, B$  and  $C$  be the unit vectors . Suppose that  $A \cdot B = A \cdot C = 0$  and the angle between  $B$  and  $C$  is  $\frac{\pi}{6}$  then prove that  $A = \pm 2(B \times C)$

 [Watch Video Solution](#)

38. The diagonals of a parallelogram are  $2\hat{i}$  and  $2\hat{j}$ .  
What is the area of the parallelogram





Watch Video Solution

39. If  $a = 3\hat{i} + \hat{j} - 4\hat{k}$ ,  $b = 6\hat{i} + 5\hat{j} - 2\hat{k}$ , then find the area of a triangle whose adjacent sides are determined by  $a$  and  $b$ .



Watch Video Solution

40. The adjacent sides of a parallelogram is given by two vector  $A$  and  $B$  where  $A = 5\hat{i} - 4\hat{j} + 3\hat{k}$  and  $B = 3\hat{i} - 2\hat{j} + \hat{k}$  Calculate the area of parallelogram .



Watch Video Solution

## Check Point 2 1

1. Which is not a vector quantity?

A. Current

B. Displacement

C. Velocity

D. Acceleration

**Answer: A**



[Watch Video Solution](#)

2. Pressure is

A. Scalar

B. vector

C. both (a) and (b)

D. none of these

**Answer: A**



**Watch Video Solution**

3. Which one of the following is not the vector quantity?

A. Torque

B. Displacement

C. Dipole moment

D. Electric flux

**Answer: D**



**Watch Video Solution**

4. Which of the following is a vector?

A. Pressure

B. Displacement

C. Moment of inertia

D. none of these



**Answer: D**



**Watch Video Solution**

**5. Surface area is**

A. Scalar

B. vector

C. Neither scalar nor vector

D. both (a) and (b)

**Answer: A**



**Watch Video Solution**

6. Which is a vector quantity?

A. Angular momentum

B. Work

C. Potential energy

D. Electirc current

**Answer: A**



**Watch Video Solution**

7. Which one is a vector quantity?

A. Work

B. momentum

C. time

D. Speed

**Answer: B**



**Watch Video Solution**

**8. Which is a vector quantity?**

A. Work

B. power

C. Torque

D. Gravitational constant

**Answer: C**



**Watch Video Solution**

9. Find the vector that must be added to the vector  $\hat{i} - 3\hat{j} + 2\hat{k}$  and  $3\hat{i} + 6\hat{j} - 7\hat{k}$  so that the resultant vector is a unit vector along the y-axis.

A.  $-4\hat{i} - 2\hat{j} + 5\hat{k}$

B.  $-4\hat{i} + 2\hat{j} + 5\hat{k}$

C.  $4\hat{i} - 2\hat{j} + 5\hat{k}$

D.  $-4\hat{i} - 2\hat{j} - 5\hat{k}$

**Answer: A**



Watch Video Solution

10. A vector multiplied by the number 0, results into

A. 0

B. A

C. O

D.  $\hat{A}$

Answer: C



Watch Video Solution

11. Which of the following represents a unit vector ?

A.  $\frac{|A|}{A}$

B.  $\frac{A}{|A|}$

C.  $\frac{A}{A}$

D.  $\frac{|A|}{|A|}$

**Answer: B**



**Watch Video Solution**

12. Unit vector does not have any

A. direction

B. magnitude

C. unit

D. All of these

**Answer: C**



**Watch Video Solution**

**13.** If  $\hat{i}$  and  $\hat{j}$  are unit vectors along X-and Y-axis respectively, then what is the magnitude and direction of  $\hat{i} + \hat{j}$  and  $\hat{i} - \hat{j}$ ?

A. 2

B. 0

C.  $\sqrt{2}$

D. 4

**Answer: C**



**Watch Video Solution**

14. The unit vector along  $\hat{i} + \hat{j}$  is

A.  $\hat{k}$

B.  $\hat{i} + \hat{j}$

C.  $\frac{\hat{i} + \hat{j}}{\sqrt{2}}$

D.  $\frac{\hat{i} + \hat{j}}{2}$



**Answer: C**



**Watch Video Solution**

**15.** What happens, when we multiply a vector by  $(-2)$

- A. direction reverses and unit changes
- B. direction reverses and magnitude gets changes
- C. direction remains unchanged and unit changes
- D. none of the above

**Answer: B**



**Watch Video Solution**

## Check Point 2 2

1.  $\vec{A} + \vec{B}$  can also be written as

A. A-B

B. B-A

C. B+A

D. B-A

**Answer: C**



**Watch Video Solution**

2. If  $P + Q = 0$ . Then which of the following is necessarily true?

A.  $P=0$

B.  $P=-Q$

C.  $Q=0$

D.  $P=Q$

**Answer: B**



**Watch Video Solution**

3. Two vector having magnitude 8 and 10 can maximum and minimum value of magnitude of their resultant as

A. 12,6

B. 10,3

C. 18,2

D. none of these

**Answer: C**



**Watch Video Solution**

4.  $\vec{P} + \vec{Q}$  is a unit vector along x-axis. If

$\vec{P} = \hat{i} - \hat{j} + \hat{k}$ , then what is  $\vec{Q}$ ?

A.  $\hat{i} + \hat{j} - \hat{k}$

B.  $\hat{j} - \hat{k}$

C.  $\hat{i} + \hat{j} + \hat{k}$

D.  $\hat{j} + \hat{k}$

**Answer: B**



**Watch Video Solution**

5. For the resultant of two vectors to be maximum , what must be the angle between them ?



[Watch Video Solution](#)

6. What are the minimum number of forces (all numerically equal) whose vector sum can be zero ?

A. Two

B. Three

C. Four

D. Any

**Answer: B**



**Watch Video Solution**

7. Given that  $P + Q + R = 0$ . Which of the following statement is true?

A.  $|P| + |Q| = |R|$

B.  $|P + Q| = |R|$

C.  $|P| - |Q| = |R|$

D.  $|P - Q| = |R|$

**Answer: B**



**Watch Video Solution**

8.  $\vec{A} = 2\hat{i} + \hat{j}$ ,  $B = 3\hat{j} - \hat{k}$  and  $\vec{C} = 6\hat{i} - 2\hat{k}$ .

value of  $\vec{A} - 2\vec{B} + 3\vec{C}$  would be

A.  $20\hat{i} + 5\hat{j} + 4\hat{k}$

B.  $20\hat{i} - 5\hat{j} - 4\hat{k}$

C.  $4\hat{i} + 5\hat{j} + 20\hat{k}$

D.  $5\hat{i} + 4\hat{j} + 10\hat{k}$

**Answer: B**



**Watch Video Solution**



9. If  $\vec{A} = 4\hat{i} - 3\hat{j}$  and  $\vec{B} = 6\hat{i} + 8\hat{j}$  then magnitude and direction of  $\vec{A} + \vec{B}$  will be

A.  $5, \tan^{-1}(3/4)$

B.  $5\sqrt{5}, \tan^{-1}(1/2)$

C.  $10, \tan^{-1}(5)$

D.  $25, \tan^{-1}(3/4)$

**Answer: B**



**Watch Video Solution**

10. A truck travelling due to north at  $20\text{ms}^{-1}$  turns west and travels at the same speed. Find the change in its velocity.

A.  $40\text{ms}^{-1}N - W$

B.  $20\sqrt{2}\text{ms}^{-1}N - W$

C.  $40\text{ms}^{-1}S - W$

D.  $20\sqrt{2}\text{ms}^{-1}S - W$

**Answer: D**



**Watch Video Solution**

11. Resultant of two vectors A and B is given by

$|R| = \{|A| - |B|\}$ . angle between A and B will be

A.  $90^\circ$

B.  $180^\circ$

C.  $0^\circ$

D. none of these

**Answer: B**



**Watch Video Solution**

12. If  $|A|=2$  and  $|B|=4$  and angle between them is  $60^\circ$

then  $|A-B|$

A.  $\sqrt{13}$

B.  $3\sqrt{3}$

C.  $\sqrt{3}$

D.  $2\sqrt{3}$

**Answer: D**



**Watch Video Solution**

13. If  $A$  and  $B$  are two vectors such that  $|A+B|=2|A-B|$ . The angle between vectors  $A$  and  $B$  is

A.  $45^\circ$

B.  $60^\circ$

C.  $30^\circ$

D. data insufficient

**Answer: D**



**Watch Video Solution**

14. if  $P + Q = P - Q$ , then

A.  $P=0$

B.  $Q=0$

C.  $P=1$

D.  $|Q|=1$

**Answer: B**



**Watch Video Solution**

**15.** Position of a particle in a rectangular -co-ordinate  
(3, 2, 5). Then its position vector will be

A.  $3\hat{i} + 5\hat{j} + 2\hat{k}$

B.  $3\hat{i} + 2\hat{j} + 5\hat{k}$

C.  $5\hat{i} + 3\hat{j} + 2\hat{k}$

D. none of these

**Answer: B**



**Watch Video Solution**

**16.** If a particle moves from point  $P(2, 3, 5)$  to point  $Q(3, 4, 5)$ . Its displacement vector be

A.  $\hat{i} + \hat{j} + 10\hat{k}$

B.  $\hat{i} + \hat{j} + 5\hat{k}$

C.  $\hat{i} + \hat{j}$

D.  $2\hat{i} + 4\hat{j} + 6\hat{k}$

**Answer: C**



**Watch Video Solution**

17. At what angle should the two force vector  $2F$  and  $\sqrt{2}F$  act so that the resultant force is  $\sqrt{10}F$ ?

A.  $45^\circ$

B.  $60^\circ$

C.  $90^\circ$

D.  $120^\circ$

**Answer: A**



**Watch Video Solution**



18. What vector must be added to the two vectors  $2\hat{i} - \hat{j} + 3\hat{k}$  and  $3\hat{i} - 2\hat{j} - 2\hat{k}$ , so that the resultant may be a unit vector along  $z$ -axis

A.  $5\hat{i} + \hat{k}$

B.  $-5\hat{i} + 3\hat{j}$

C.  $3\hat{i} + 5\hat{k}$

D.  $-3\hat{i} + 2\hat{k}$

**Answer: B**



**Watch Video Solution**

19. Three vector each of magnitude  $A$  are acting at a point such that angle between any two consecutive vectors in same plane is  $60^\circ$  The magniude of their resultant is

A.  $2A$

B.  $\sqrt{2}A$

C.  $\sqrt{3}A$

D.  $\sqrt{6}A$

**Answer: A**



**Watch Video Solution**

20. Three forces acting on a body are shown in figure.

To have the resultant force only along the y-direction,

the magnitude of the minimum additional force

needed is

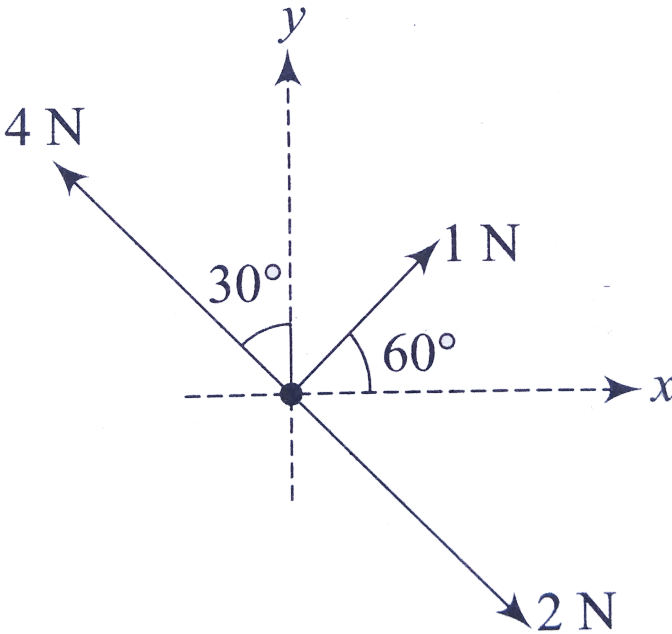

A.  $\frac{\sqrt{3}}{4} N$

B.  $\sqrt{3} N$

C.  $0.5N$

D.  $1.5N$

**Answer: C**



**Watch Video Solution**

### Check Point 2 3

1. The work done by a force  $F = (\hat{i} + 2\hat{j} + 3\hat{k})$  N ,to displace a body from position A to position B is [The position vector of A is  $r_1 = (2\hat{i} + 2\hat{j} + 3\hat{k})m$  The position vector of B is  $r_2 = (3\hat{i} + \hat{j} + 5\hat{k})m$  ]

A. 5 J

B. 3 J

C. 2 J

D. 10 J

**Answer: A**



**Watch Video Solution**

2. The condition  $(a \cdot b)^2 = a^2 b^2$  is satisfied when

A.  $a$  is parallel to  $b$

B.  $a \neq b$

C.  $a \cdot b = 1$

D.  $a \perp b$

**Answer: A**



**Watch Video Solution**

3. The modulus of the vector product of two vector is  $\frac{1}{\sqrt{3}}$  times their scalar product . The angle between vectors is

A.  $\frac{\pi}{6}$

B.  $\frac{\pi}{2}$

C.  $\frac{\pi}{4}$

D.  $\frac{\pi}{3}$

**Answer: A**



**Watch Video Solution**

4. Three vectors satisfy the relation  $A \cdot B = 0$  and  $A \cdot C = 0$   
then  $A$  is parallel to

A.  $B$

B.  $C$

C.  $B \cdot C$

D.  $B \times C$

**Answer: D**



**Watch Video Solution**

5. what is the dot product of two vectors of magnitudes 3 and 5,if angle between them is  $60^\circ$  ?

A. 5.2

B. 7.5

C. 8.4

D. 8.6

**Answer: B**



**Watch Video Solution**



6. When  $A \cdot B = -|A||B|$ , then

- A. A and B are perpendicular to each other
- B. A and B act in the same direction
- C. A and B act in the opposite direction
- D. A and B can act in any in any direction

**Answer: C**



**Watch Video Solution**

7. The vector projection of a vector  $3\hat{i} + 4\hat{k}$  on y-axis is

- A. 5

B. 4

C. 3

D. Zero

**Answer: D**



**Watch Video Solution**

**8. In a clockwise system :-**

A.  $\hat{j} \times \hat{k} = \hat{i}$

B.  $\hat{k} \cdot \hat{i} = 1$

C.  $\hat{i} \cdot \hat{i} = 0$

D.  $\hat{j} \times \hat{j} = 1$

**Answer: A**



**Watch Video Solution**

9. If  $|A \times B| = \sqrt{3}A \cdot B$ , then the value of  $|A+B|$  is

A.  $\left( A^2 + B^2 + \frac{AB}{\sqrt{3}} \right)^{1/2}$

B.  $A+B$

C.  $(A^2 + B^2 + \sqrt{3}AB)^{1/2}$

D.  $(A^2 + B^2 + AB)^{1/2}$

**Answer: D**



**Watch Video Solution**

10. If  $|A| = 2$ ,  $|B| = 5$  and  $|A \times B| = 8$ . Angle between A and B is acute, then  $(A \cdot B)$  is

A. 6

B. 3

C. 4

D. 7

**Answer: A**



**Watch Video Solution**

11. Find the torque of a force  $\vec{F} = -3\hat{i} + 2\hat{j} + \hat{k}$  acting at the point  $\vec{r} = 8\hat{i} + 2\hat{j} + 3\hat{k}$  about origin

A.  $14\hat{i} - 38\hat{j} + 16\hat{k}$

B.  $4\hat{i} + 4\hat{j} + 6\hat{k}$

C.  $-14\hat{i} + 38\hat{j} - 16\hat{k}$

D.  $-4\hat{i} + 17\hat{j} - 22\hat{k}$

**Answer: D**



**Watch Video Solution**

12. What is the unit vector perpendicular to the following vectors  $2\hat{i} + 2\hat{j} - \hat{k}$  and  $6\hat{i} - 3\hat{j} + 2\hat{k}$

A.  $\frac{\hat{i} + 10\hat{j} - 18\hat{k}}{5\sqrt{17}}$

B.  $\frac{\hat{i} - 10\hat{j} + 18\hat{k}}{5\sqrt{17}}$

C.  $\frac{\hat{i} - 10\hat{j} - 18\hat{k}}{5\sqrt{17}}$

D.  $\frac{\hat{i} + 10\hat{j} + 18\hat{k}}{5\sqrt{17}}$

**Answer: C**



**Watch Video Solution**

13. The angle between vectors  $(A \times B)$  and  $(B \times A)$  is

A. Zero

B.  $\pi$

C.  $\frac{\pi}{4}$

D.  $\frac{\pi}{2}$

**Answer: B**



**Watch Video Solution**

14. What is the value of linear velocity, if

$$\vec{\omega} = 3\hat{i} - 4\hat{j} + \hat{k} \text{ and } \vec{r} = 5\hat{i} - 6\hat{j} + 6\hat{k}?$$



Watch Video Solution

15. Find the area of the parallelogram determined

$$A = 2\hat{i} + \hat{j} - 3\hat{k} \text{ and } B = 12\hat{j} - 2\hat{k}$$

A. 43

B. 56

C. 38

D. 74



**Answer: A**



**Watch Video Solution**

## Chapter Exercises

1. The vector quantity among the following is

A. mass

B. time

C. distance

D. displacement

**Answer: D**



[Watch Video Solution](#)

2. A vector is added to an equal and opposite vector of similar nature, forms a

- A. unit vector
- B. position vector
- C. null vector
- D. displacement vector

**Answer: C**



[Watch Video Solution](#)

3. Out of the following quantities, which is scalar?

A. Displacement

B. momentum

C. Potential energy

D. Torque

**Answer: C**



**Watch Video Solution**

4. Which of the following is a unit vector ?

A.  $\hat{i} + \hat{j}$

B.  $\cos \theta \hat{i} - \sin \theta \hat{j}$

C.  $\sin \theta \hat{i} + 2 \cos \theta \hat{j}$

D.  $\frac{1}{\sqrt{3}} (\hat{i} + \hat{j})$

**Answer: B**



**Watch Video Solution**

5. The component of a vector is

A. always less than its magnitude

B. always greater than its magnitude

C. always equal to its magnitude

D. none of the above

**Answer: A**



**Watch Video Solution**

6. The expression  $\left( \frac{1}{\sqrt{2}} \hat{i} + \frac{1}{\sqrt{2}} \hat{j} \right)$  is a

A. unit vector

B. null vector

C. vector of magnitude  $\sqrt{2}$

D. Scalar

**Answer: A**



**Watch Video Solution**

7. The position vector of a moving particle at time  $t$  is

$r = 3\hat{i} + 4t\hat{j} - t\hat{k}$  Its displacement during the time interval  $t = 1$  s to  $t=3$  s is

A.  $\hat{j} - \hat{k}$

B.  $3\hat{i} + 4\hat{j} - \hat{k}$

C.  $9\hat{i} + 36\hat{j} - 27\hat{k}$

D. None of the above

**Answer: D**



**Watch Video Solution**

8. Vector  $P = 6\hat{i} + 4\sqrt{2}\hat{j} + 4\sqrt{2}\hat{k}$  makes angle from Z-axis equal to

A.  $\cos^{-1}\left(\frac{\sqrt{2}}{5}\right)$

B.  $\cos^{-1}(2\sqrt{2})$

C.  $\cos^{-1}\frac{2\sqrt{2}}{5}$

D. None of these

**Answer: C**



**Watch Video Solution**

9. Given :

$\vec{A} = \hat{i} + \hat{j} + \hat{k}$  and  $\vec{B} = -\hat{i} - \hat{j} - \hat{k}$  What is the angle between  $(\vec{A} - \vec{B})$  and  $\vec{A}$  ?

A.  $0^\circ$

B.  $180^\circ$

C.  $90^\circ$

D.  $60^\circ$

**Answer: A**



**Watch Video Solution**



10. Which of the following Statement is true?

A. When the coordiante axes are translated the component of a vector in a plane changes.

B. When the coording axces are rotated though some angle components of the vector change but vector 's magnitude remain constant.

C. Sum of a and b is R If the magnitude of a alone is increased angle between b and R decreases.

D. The cross product of  $3\hat{i}$  and  $4\hat{j}$  is 12.

**Answer: B**



**Watch Video Solution**

11. The component of vector  $A = 2\hat{i} + 3\hat{j}$  along the vector  $\hat{i} + \hat{j}$  is

A.  $\frac{5}{\sqrt{2}}$

B.  $4\sqrt{2}$

C.  $\frac{\sqrt{2}}{3}$

D. None of these

**Answer: A**



**Watch Video Solution**

12. A vector  $P = 3\hat{i} - 2\hat{j} + a\hat{k}$  is perpendicular to the vector  $Q = 2\hat{i} + \hat{j} - \hat{k}$ , The value of  $a$  is

A. 2

B. 1

C. 4

D. 3

**Answer: C**



**Watch Video Solution**

13. If three vector along coordinate axis represent the adjacent sides of a cube of length b, then the unit vector along its diaonal passing thourth the origin will be

A.  $\frac{\hat{i} + \hat{j} + \hat{k}}{\sqrt{2}}$

B.  $\frac{\hat{i} + \hat{j} + \hat{k}}{\sqrt{36}}$

C.  $\hat{i} + \hat{j} + \hat{k}$

D.  $\frac{\hat{i} + \hat{j} + \hat{k}}{\sqrt{3}}$

**Answer: D**



**Watch Video Solution**

14. The angle between two vectors  $-2\hat{i} + 3\hat{j} + \hat{k}$  and  $\hat{i} + 2\hat{j} - 4\hat{k}$  is

A.  $45^\circ$

B.  $90^\circ$

C.  $30^\circ$

D.  $60^\circ$

**Answer: B**



**Watch Video Solution**

15. The angle between the vector  $2\hat{i} + \hat{j} + \hat{k}$  and  $\hat{j}$ ?

A.  $\frac{\pi}{6}$

B.  $\frac{\pi}{4}$

C.  $\frac{\pi}{3}$

D. None of these

**Answer: B**



**Watch Video Solution**

**16.** What is the angle between  $\hat{i} + \hat{j} + \hat{k}$  and  $\hat{j}$ ?

A.  $\frac{\pi}{6}$

B.  $\frac{\pi}{4}$

C.  $\frac{\pi}{3}$

D. none of these

Answer: D



Watch Video Solution

17. Which of the following is the unit vector perpendicular to  $\vec{A}$  and  $\vec{B}$ ?

A.  $\frac{\hat{A} \times \hat{B}}{AB \sin \theta}$

B.  $\frac{\hat{A} \times \hat{B}}{AB \cos \theta}$

C.  $\frac{A \times B}{AB \sin \theta}$

D.  $\frac{A \times B}{AB \cos \theta}$

Answer: C



Watch Video Solution

18. If  $\frac{|a + b|}{|a - b|} = 1$ , then the angle between  $a$  and  $b$  is

A.  $0^\circ$

B.  $45^\circ$

C.  $90^\circ$

D.  $60^\circ$

**Answer: C**



**Watch Video Solution**



19. A man walk 20 m at an angle  $60^\circ$  north of east . How far towards east has he he travelled ?

A. 10 m

B. 20 m

C.  $20\sqrt{3}$  m

D.  $10\sqrt{3}$ m

**Answer: A**



[Watch Video Solution](#)

20. If  $A=B$  , then which of the following is not correct ?

A.  $\hat{A} = \hat{B}$

B.  $|A| = |B|$

C.  $A\hat{B} = B\hat{A}$

D.  $A + B = \hat{A} + \hat{B}$

**Answer: D**



**Watch Video Solution**

21. The area of the parallelogram represented by the vectors  $\vec{A} = 2\hat{i} + 3\hat{j}$  and  $\vec{B} = \hat{i} + 4\hat{j}$  is

A. 14 unit

B. 7.5 units

C. 10 unit

D. 5 units

**Answer: D**



**Watch Video Solution**

**22.** The forces, which meet at one point but their line of action do not lie in one plane, are called

A. non-coplanar non-concurrent forces

B. non-coplanar concurrent forces

C. coplanar concurrent forces

D. coplanar non-concurrent forces

**Answer: B**



**Watch Video Solution**

**23.** If the angle between two vectors  $A$  and  $B$  is  $120^\circ$ , then its resultant  $C$  will be

A.  $C = |A - B|$

B.  $C < |A - B|$

C.  $C > |A - B|$

D.  $C = |A + B|$

**Answer: C**



**Watch Video Solution**

24. The condition under which the vector  $(a+b)$  and  $(a-b)$  are parallel is

A.  $a \perp b$

B.  $|a| = |b|$

C.  $a \neq b$

D.  $A \parallel B$

**Answer: D**



**Watch Video Solution**

25. A body, under the action of a force  $\vec{F} = 6\hat{i} - 8\hat{j} + 10\hat{k}$ , acquires an acceleration of  $1\text{ms}^{-2}$ . The mass of this body must be.

A. 200 kg

B. 20kg

C.  $10\sqrt{2}\text{kg}$

D.  $6\sqrt{2}\text{kg}$

**Answer: C**



**Watch Video Solution**

26. The vector sum of two forces is perpendicular to their vector differences. In that case, the forces

- A. are not equal to each other in magnitude
- B. are parallel
- C. are perpendicular
- D. are equal to each other in magnitude

**Answer: D**



**Watch Video Solution**

27. The resultant of  $\vec{a}$  and  $\vec{b}$  makes  $\alpha$  with  $\vec{a}$  and  $\beta$  with  $\vec{b}$ , then (a,b represent magnitudes of respective vectors) :

A.  $\alpha < \beta$

B.  $\alpha > \beta$  if  $A < B$

C.  $\alpha < \beta$  if  $A = B$

D.  $\alpha < \beta$  if  $A < B$

**Answer: B**



**Watch Video Solution**



**28.** Two equal vector have a resultant equal to either of them, then the angle between them will be:

A.  $60^\circ$

B.  $120^\circ$

C.  $90^\circ$

D.  $0^\circ$

**Answer: B**



**Watch Video Solution**

29. If A and B are Two non -zero vector having equal magnitude , the angle between the vector A and A-B is

A.  $0^\circ$

B.  $90^\circ$

C.  $180^\circ$

D. dependent on the orientation o fA and B

**Answer: D**



**Watch Video Solution**

30. The angle between  $\vec{A} = \hat{i} + \hat{j}$  and  $\vec{B} = \hat{i} - \hat{j}$  is

A.  $45^\circ$

B.  $90^\circ$

C.  $-45^\circ$

D.  $180^\circ$

**Answer: B**



**Watch Video Solution**

**31.** Five equal forces of  $10N$  each are applied at one point and all are lying one plane. If the angles between them are equal, the resultant force will be

A. zero

B. 10N

C. 20N

D.  $10\sqrt{2}N$

**Answer: A**



**Watch Video Solution**

32. Two vectors  $\vec{A}$  and  $\vec{B}$  inclined at an angle  $\theta$  have a resultant  $\vec{R}$  which makes an angle  $\alpha$  with  $\vec{A}$ . If the directions of  $\vec{A}$  and  $\vec{B}$  are interchanged, the resultant will have the same

A. magnitude the same

B. direction reverses and magnitude is doubled

C. magnitude as well as direction

D. Neither

**Answer: A**



**Watch Video Solution**

**33. What is correct ?**

A.  $|a - b| = |a| - |b|$

B.  $|a - b| \leq |a| - |b|$

C.  $|a - b| \geq |a| - |b|$

D.  $|a - b| > |a| - |b|$

**Answer: C**



**Watch Video Solution**

**34.** Resultant of which of a following may be equal to zero?

A.  $10N, 10N, 10N$

B.  $10N, 10N, 25N$

C.  $10N, 10N, 35N$

D. None of these

**Answer: A**



**Watch Video Solution**

35. A man first moves 3 m due east , then 6 m due north and finally 7 m due west , then the magnitude of the resultant displacement is (in metre)

A.  $\sqrt{16}$

B.  $\sqrt{24}$

C.  $\sqrt{52}$

D.  $\sqrt{94}$

**Answer: C**



**Watch Video Solution**

36. The resultant of two forces  $3P$  and  $2P$  is  $R$ . If the first force is doubled then resultant is also doubled. The angle between the two forces is

A.  $60^\circ$

B.  $120^\circ$

C.  $90^\circ$

D.  $180^\circ$

**Answer: B**



**Watch Video Solution**



37. Two forces 8 N and 12 act ay  $120^\circ$  The third force required to keep the body in equilibrium is

A. 4 N

B.  $4\sqrt{7}N$

C. 20 N

D. none of these

**Answer: B**



**Watch Video Solution**

38. If  $A \cdot B = 0$  and  $A \times B = 1$ , then A and B are

A. perpendicular unit vectors

B. paraellel unit vector

C. parallel

D. anti - parallel

**Answer: A**



[Watch Video Solution](#)

39.

If

$P + Q = R$  and  $|P| = |Q| = \sqrt{3}$  and  $|R| = 3$ ,

then the angle between P and Q is

A.  $\pi / 4$

B.  $\pi / 6$

C.  $\pi / 3$

D.  $\pi / 2$

**Answer: C**



**Watch Video Solution**

**40.** The component of a vector  $r$  along X-axis will have maximum value if

A.  $r$  is along positive Y-axis

B.  $r$  is along positive x-axis

C.  $x$  makes an angle of  $45^\circ$  with the X-axis

D.  $r$  is along negative Y-axis

Answer: B

 Watch Video Solution

41. Six vectors  $a$  to  $f$  have the magnitude and direction indicated in the figure. Which of the following statement is true ?

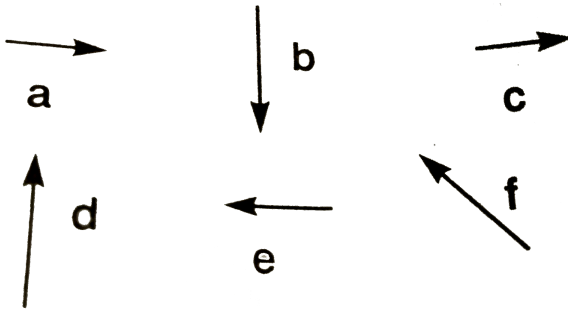

A.  $b + e = f$

B.  $b + c = f$

C.  $d + c = f$

D.  $d + e = f$

**Answer: D**



**Watch Video Solution**

**42.** A particle starting from the origin  $(0,0)$  moves in a straight line in  $(x, y)$  plane. Its coordinates at a later time are  $(\sqrt{3}, 3)$ . The path of the particle makes with the x-axis an angle of

A.  $30^\circ$

B.  $45^\circ$

C.  $60^\circ$

D.  $0^\circ$

**Answer: C**



**Watch Video Solution**

**43.** Consider a vector  $\vec{F} = 4\hat{i} - 3\hat{j}$ . Another vector that is perpendicular to  $\vec{F}$  is

A.  $4\hat{i} + 3\hat{j}$

B.  $6\hat{i}$

C.  $7\hat{k}$

D.  $3\hat{i} - 4\hat{j}$

**Answer: C**

 [Watch Video Solution](#)

**44.** The angle between vectors  $(A \times B)$  and  $(B \times A)$  is

 [Watch Video Solution](#)

**45.** The angle between vectors  $(A \times B)$  and  $(B \times A)$  is

 [Watch Video Solution](#)

46. Unit vector perpendicular to vector

$A = -3\hat{i} - 2\hat{j} - 3\hat{k}$  and  $2\hat{i} + 4\hat{j} + 6\hat{k}$  is

A.  $\frac{3\hat{i} - 2\hat{k}}{\sqrt{13}}$

B.  $\frac{3\hat{k} - 2\hat{j}}{\sqrt{13}}$

C.

D.

**Answer: A**



**Watch Video Solution**



47. Unit vector parallel to the resultant of vector  $8\hat{i}$  and  $8\hat{j}$  will be

A.  $(24\hat{i} + 5\hat{j}) / 13$

B.  $(12\hat{i} + 5\hat{j}) / 13$

C.  $(6\hat{i} + 5\hat{j}) / 13$

D. None of these

**Answer: D**



**Watch Video Solution**

**48.** A force of  $5N$  acts on a particle along a direction making an angle of  $60^\circ$  with verticle. Its verticel components is

A. 10N

B. 3 N

C. 4 N

D. 2.5 N

**Answer: D**



**Watch Video Solution**

49. If  $\vec{A} = 3\hat{i} + 4\hat{j}$  and  $\vec{B} = 7\hat{i} + 24\hat{j}$ , find a vector having the same magnitude as  $\vec{B}$  and parallel and same direction as  $\vec{A}$ .

A.  $5\hat{i} + 20\hat{j}$

B.  $15\hat{i} + 10\hat{j}$

C.  $20\hat{i} + 15\hat{j}$

D.  $15\hat{i} + 20\hat{j}$

**Answer: D**



**Watch Video Solution**

50. The vector that must be added to the vector  $\hat{i} - 4\hat{j} + 2\hat{k}$  and  $3\hat{i} + 3\hat{j} - 7\hat{k}$  so that the resultant vector is a unit vector along the y-axis is

A.  $4\hat{i} + 2\hat{j} + 5\hat{k}$

B.  $-4\hat{i} + 2\hat{j} + 5\hat{k}$

C.  $3\hat{i} + 4\hat{j} + 5\hat{k}$

D. Null vector

**Answer: B**



**Watch Video Solution**

51. A vector is represented by  $3\hat{i} + \hat{j} + 2\hat{k}$ . Its length in  $XY$  plane is

A. 2

B.  $\sqrt{14}$

C.  $\sqrt{10}$

D.  $\sqrt{5}$

**Answer: C**



**Watch Video Solution**

52. Let  $\vec{A} = \hat{i}A \cos \theta + \hat{j} \sin \theta$ , be any vector. Another vector  $\vec{B}$  which is normal to  $\vec{A}$  is :

A.  $\hat{i}B \cos \theta - \hat{j}B \sin \theta$

B.  $\hat{i}B \sin \theta - \hat{j}B \cos \theta$

C.  $\hat{i}B \sin \theta + \hat{j}B \cos \theta$

D.  $\hat{i}B \sin \theta + \hat{j}B \cos \theta$

**Answer: B**



**Watch Video Solution**

53. If two vectors  $2\hat{i} + 3\hat{j} - \hat{k}$  and  $-4\hat{i} - 6\hat{j} - \lambda\hat{k}$  are parallel to each other then value of  $\lambda$  be

A. 0

B. 2

C. 3

D. 4

**Answer: B**



**Watch Video Solution**

54. What is the angle between  $(\vec{P} + \vec{Q})$  and  $(\vec{P} \times \vec{Q})$ ?

A. Zero

B.  $\frac{\pi}{2}$

C.  $\frac{\pi}{4}$

D.  $\pi$

**Answer: B**



**Watch Video Solution**



55. If a unit vector is represented by  $0.5\hat{i} + 0.8\hat{j} + c\hat{k}$ ,

then the value of  $c$  is

A. 1

B.  $\sqrt{0.11}$

C.  $\sqrt{0.01}$

D.  $\sqrt{0.39}$

**Answer: B**



**Watch Video Solution**

56. If  $A = a_1\hat{i} + b_1\hat{j}$  and  $B = a_2\hat{i} + b_2\hat{j}$  the condition that they are perpendicular to each other is

A.  $\frac{a_1}{b_1} = -\frac{b_2}{a_2}$

B.  $a_1b_1 = a_2b_2$

C.  $\frac{a_1}{b_1} = -\frac{b_1}{b_2}$

D. None of these

**Answer: A**



**Watch Video Solution**

57. For what value of  $x$  , will the two vector  $A = 2\hat{i} + 2\hat{j} - x\hat{k}$  and  $B = 2\hat{i} - \hat{j} - 3\hat{k}$  are perpendicular to each other ?

A.  $x = -2/3$

B.  $x = -3/2$

C.  $x = -4/3$

D.  $x = -2/3$

**Answer: A**



**Watch Video Solution**

58. A and B are two vector given by  $A = 2\hat{i} + 3\hat{j}$  and  $B = 2\hat{i} + 4\hat{j}$  The magnitude to the component of A along B is

A.  $\frac{5}{\sqrt{2}}$

B.  $\frac{3}{\sqrt{2}}$

C.  $\frac{8}{\sqrt{5}}$

D.  $\frac{5}{\sqrt{13}}$

**Answer: C**



**Watch Video Solution**

59. The value of  $x$  and  $y$  for which vector  $A = (6\hat{i} + x\hat{j} - 2\hat{k})$  and  $B = (5\hat{i} + 6\hat{j} - y\hat{k})$  may be parallel are

A.  $x = 0, y = \frac{2}{3}$

B.  $x = \frac{36}{5}, y = \frac{5}{3}$

C.  $x = \frac{15}{3}, y = \frac{23}{3}$

D.  $x = \frac{36}{5}, y = \frac{15}{4}$

**Answer: B**



**Watch Video Solution**

60. The angles which the vector  $A = 3\hat{i} + 6\hat{j} + 2\hat{k}$  makes with the co-ordinate axes are

A.  $\cos^{-1} \frac{3}{7}$   $\cos^{-1} \frac{6}{7}$  and  $\cos^{-1} \frac{2}{7}$

B.  $\cos^{-1} \frac{4}{7}$   $\cos^{-1} \frac{5}{7}$  and  $\cos^{-1} \frac{3}{7}$

C.  $\cos^{-1} \frac{3}{7}$   $\cos^{-1} \frac{4}{7}$  and  $\cos^{-1} \frac{1}{7}$

D. None of the above

**Answer: A**



**Watch Video Solution**

61. A particle is moving on a circular path with constant speed  $v$  then the change in its velocity after it has described an angle of  $60^\circ$  will be

A.  $v\sqrt{2}$

B.  $\frac{v}{2}$

C.  $v\sqrt{3}$

D.  $v$

**Answer: D**



**Watch Video Solution**

62. Find the resultant of the three vectors  $\vec{OA}$ ,  $\vec{OB}$  and  $\vec{OC}$  shown in figure. Radius of the circle is  $R$ .

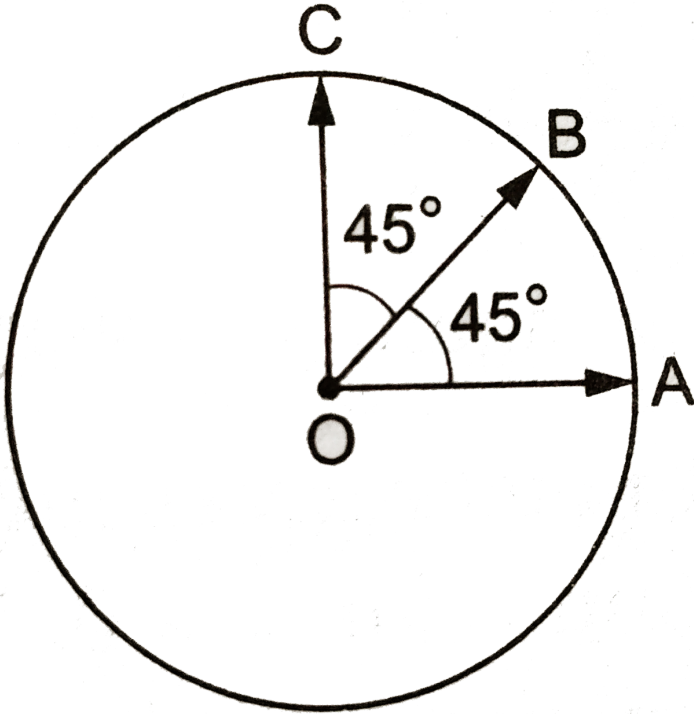

A.  $2R$

B.  $R(1 + \sqrt{2})$

C.  $R\sqrt{2}$



D.  $R(\sqrt{2} - 1)$

**Answer: B**



**Watch Video Solution**

**63.** Resultant of two vector of equal magnitude A is

A.  $\sqrt{3}A$  at  $60^\circ$

B.  $\sqrt{2}A$  at  $90^\circ$

C.  $2A$  at  $120^\circ$

D.  $A$  at  $180^\circ$

**Answer: A,B**



Watch Video Solution

64. If  $a\hat{i} + b\hat{j}$  is a unit vector and it is perpendicular to  $\hat{i} + \hat{j}$ , then value of a and b is

A. 1,0

B. -2, 0

C. 0.5, -0.5

D. None of these

**Answer: D**



Watch Video Solution

65. If  $a + b + c = 0$ , then  $a \times b$  is equal to

A.  $b \times c$

B.  $c \times b$

C.  $a \times c$

D. None of these

**Answer: A**



**Watch Video Solution**

66. Consider a force vector  $F = \hat{i} + \hat{j} + \hat{k}$  Another vector perpendicular to F is

A.  $4\hat{i} + 3\hat{j}$

B.  $6\hat{i}$

C.  $2\hat{i} - \hat{j} - \hat{k}$

D.  $3\hat{i} - 4\hat{j}$

**Answer: C**



**Watch Video Solution**

**67.** A vector perpendicular to both the vector  $2\hat{i} - 3\hat{j}$  and  $3\hat{i} - 2\hat{j}$  is

A.  $\hat{j} + 5\hat{k}$

B.  $\hat{j} - 5\hat{k}$

C.  $6\hat{k}$

D.  $\hat{i} + \hat{j} + \hat{k}$

**Answer: C**



**Watch Video Solution**

68. If  $\vec{A} = 4\hat{i} - 3\hat{j}$  and  $\vec{B} = 6\hat{i} + 8\hat{j}$  then magnitude and direction of  $\vec{A} + \vec{B}$  will be

A.  $5, \tan^{-1}(3/4)$

B.  $5\sqrt{5}, \tan^{-1}(1/2)$

C.  $10, \tan^{-1}(5)$

D.  $25, \tan^{-1}(3/4)$

**Answer: B**



**Watch Video Solution**

**69.** When a force  $F$  acts on a body of mass  $m$  the acceleration produced in the body is  $a$ . If three equal forces  $F_1 = F_2 = F_3 = F$  act on the same body as

shown in figure the acceleration produced is

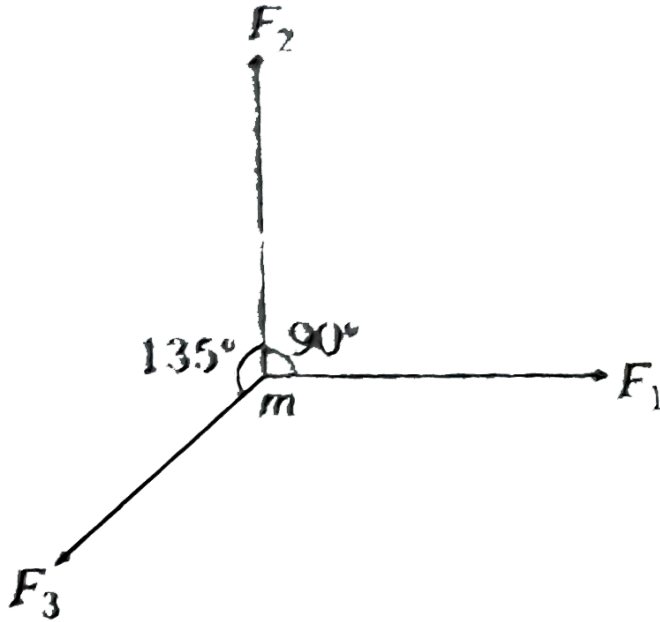

- A.  $(\sqrt{2} - 1)a$
- B.  $(\sqrt{2} + 1)a$
- C.  $\sqrt{2}a$
- D.  $a$

**Answer: A**



Watch Video Solution

70. Obtain the magnitude and direction cosines of vector  $(A - B)$ , if

$$A = 2\hat{i} + 3\hat{j} + \hat{k}, B = 2\hat{i} + 2\hat{j} + 3\hat{k}$$

A.  $0, \frac{1}{\sqrt{5}}, \frac{-2}{\sqrt{5}}$

B.  $0, \frac{2}{\sqrt{5}}, \frac{1}{\sqrt{5}}$

C.  $0, 0, \frac{1}{\sqrt{5}}$

D. None of these

**Answer: A**



Watch Video Solution



71. Two vectors having equal magnitudes  $A$  make an angle  $\theta$  with each other. Find the magnitude and direction of the resultant.

A.  $2A \cos \frac{\theta}{2}$ , along bisector

B.  $A \cos \frac{\theta}{2}$ , at  $45^\circ$  from on a vector

C.  $2A \cos \frac{\theta}{2}$ , along bisector

D.  $A \cos \frac{\theta}{2}$ , along bisector

**Answer: A**



**Watch Video Solution**

72. 12 coplanar non collinear forces (all of equal magnitude) maintain a body in equilibrium, then angle between any two adjacent forces is

A.  $15^\circ$

B.  $30^\circ$

C.  $45^\circ$

D.  $60^\circ$

**Answer: B**



**Watch Video Solution**

73. Given that  $\vec{A} + \vec{B} + \vec{C} = 0$ , out of three vectors two are equal in magnitude and the magnitude of third vector is  $\sqrt{2}$  times that of either of two having equal magnitude. Then angle between vectors are given by

A.  $30^\circ, 60^\circ, 90^\circ$

B.  $45^\circ, 45^\circ, 90^\circ$

C.  $90^\circ, 135^\circ, 45^\circ$

D.  $90^\circ, 135^\circ, 135^\circ$

**Answer: D**



**Watch Video Solution**

74. Two vectors  $A$  and  $B$  are such that  $A + B = C$  and  $A^2 + B^2 = C^2$ . If  $\theta$  is the angle between positive direction of  $A$  and  $B$ , then the correct statement is

A.  $\theta = \pi$

B.  $\theta = \frac{2\pi}{3}$

C.  $\theta = 0$

D.  $\theta = \frac{\pi}{2}$

**Answer: D**



**Watch Video Solution**

75. Given  $A = 3\hat{i} + 4\hat{j}$  and  $B = 6\hat{i} + 8\hat{j}$  which of the following statement is correct ?

A.  $A \times B = 0$

B.  $\frac{|A|}{|B|} = \frac{1}{2}$

C.  $|A| = 15$

D.  $A \cdot |B| = 48$

**Answer: A,B**



**Watch Video Solution**

76. If a vector  $\vec{A}$  make angles  $\alpha, \beta$  and  $\gamma$ , respectively, with the  $X, Y$  and  $Z$  axes, then  $\sin^2 \alpha + \sin^2 \beta + \sin^2 \gamma =$

A. 0

B. 1

C. 2

D. 3

**Answer: C**



**Watch Video Solution**

77. If vector A and B have an angle  $\theta$  between them, then value of  $|\hat{A} - \hat{B}|$  will be ,

A.  $2 \cos \frac{\theta}{2}$

B.  $2 \tan \frac{\theta}{2}$

C.  $2 \sin \frac{\theta}{2}$

D. None of these

**Answer: C**



**Watch Video Solution**

78. A particle undergoes three successive displacements given by  $s_1 = \sqrt{2}$  m north - east ,  $s_2 = 2$  m due south and  $s_3 = 4m, 30^\circ$  north of west , then magnitude of net displacement is

A.  $\sqrt{14 + 4\sqrt{3}}$

B.  $\sqrt{14 - 4\sqrt{3}}$

C.  $\sqrt{4}$

D. None of these

**Answer: B**



**Watch Video Solution**



79. The resultant of A and B is  $R_1$ . On reversing the vector B, the resultant  $R_2$  what is the value of  $R_1^2 + R_2^2$ ?

A.  $A^2 + B^2$

B.  $A^2 - B^2$

C.  $2(A^2 + B^2)$

D.  $2(A^2 - B^2)$

**Answer: C**



**Watch Video Solution**

**80.** If the sum of two unit vectors is a unit vector, then magnitude of difference is-

A.  $\sqrt{2}$

B.  $\sqrt{3}$

C.  $1/\sqrt{2}$

D.  $\sqrt{5}$

**Answer: B**



**Watch Video Solution**

**81.** The sum of two vectors A and B is at right angles to their difference. Then

A.  $A=B$

B.  $A=2B$

C.  $B=2A$

D. None of these

**Answer: A**



**Watch Video Solution**

**82.** A vector having magnitude 30 unit makes equal angles with each of X,Y, and Z -axes The components of vector along each of X,Y,and Z -axes are

A.  $10\sqrt{3}$  unit

B.  $20\sqrt{3}$  unit

C.  $15\sqrt{3}$  unit

D. 10 unit

**Answer: A**



**Watch Video Solution**

83. A number of vectors are as shown in .They can be combined in various ways , like  $\vec{A} + \vec{C} = \vec{B}$  . What is the value of (a)  $\vec{E} + \vec{C}$  (b)  $\vec{A} + \vec{F}$  (c )  $\vec{A} + \vec{D}$  (d)  $\vec{E} + \vec{A}$  (e)  $\vec{A} - \vec{B}$  .

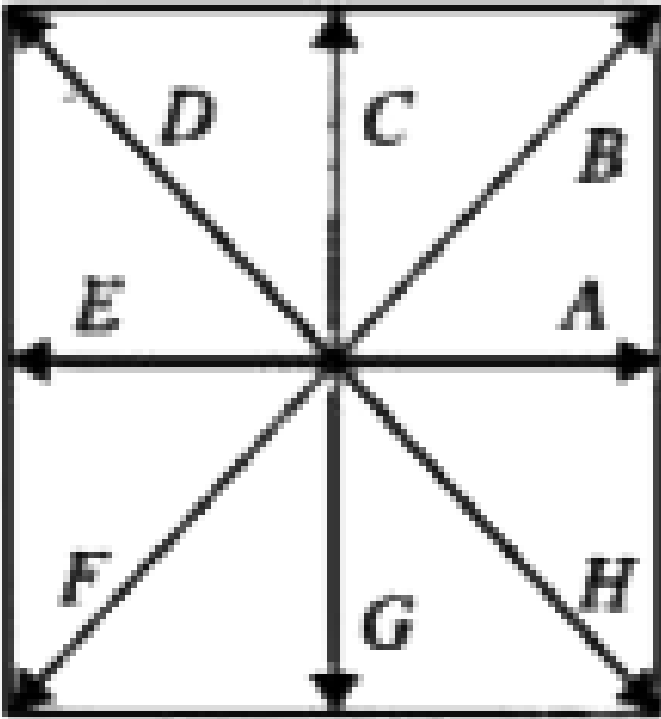

A. AO

B. 2AO

C. 4AO

D. 6AO

**Answer: D**



[Watch Video Solution](#)

**84.** If  $\hat{A}$  is a unit vector in a given direction then the

value of  $\hat{A} \cdot \frac{d\hat{A}}{dt}$  is

A. 0

B. 1

C.  $\frac{1}{2}$

D. 2

**Answer: A**



**Watch Video Solution**

**85.** If  $F_1$  and  $F_2$  are two vectors of equal magnitudes  $F$  such that  $|F_1 \cdot F_2| = |F_1 \times F_2|$ , then  $|F_1 + F_2|$  equals to

A.  $\sqrt{(2 + \sqrt{2})} F$

B.  $2F$

C.  $F\sqrt{2}$

D. None of these

Answer: A



Watch Video Solution

86. Figure show's three vectors  $p, q$  and  $r$  where  $C$  is the mid - point of  $AB$  Then which of the following relation is correct ?

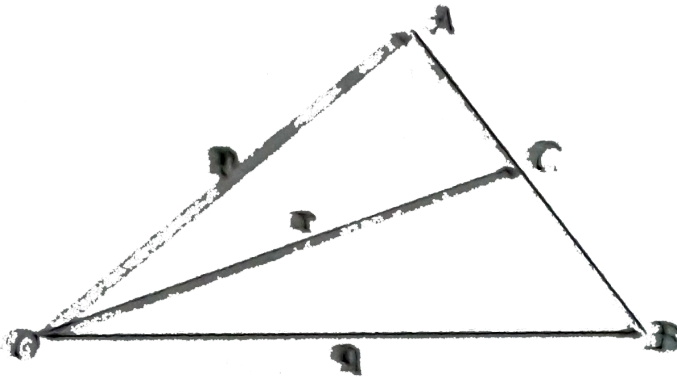

A.  $p + q = 2r$

B.  $p + q = r$



C.  $p - q = 2r$

D.  $p - q = r$

**Answer: A**



**Watch Video Solution**

**87.** What is the angle between  $P$  and  $Q$  the cross product of  $(P + Q)$  and  $(P - Q)$ ?

A.  $90^\circ$

B.  $\tan^{-1}(p/Q)$

C.  $\tan^{-1}(Q/p)$

D.  $0^\circ$

**Answer: A**



**Watch Video Solution**

**88.** The resultant of two vectors  $\vec{P}$  and  $\vec{Q}$  is  $\vec{R}$ . If  $\vec{Q}$  is doubled then the new resultant vector is perpendicular to  $\vec{P}$ . Then magnitude of  $\vec{R}$  is :-

A. P

B.  $(P + Q)$

C. Q

D.  $(P - Q)$

**Answer: C**



Watch Video Solution

89. The angle between the vector  $\vec{A}$  and  $\vec{B}$  is  $\theta$ . Find the value of triple product  $\vec{A} \cdot (\vec{B} \times \vec{A})$ .

A.  $a^2 B$

B. zero

C.  $A^2 B \sin \theta$

D.  $A^2 B \cos \theta$

**Answer: B**



Watch Video Solution

**90.** The sum of the magnitudes of two forces acting at a point is 18 and the magnitude of their resultant is 12. If the resultant is at  $90^\circ$  with the force of smaller magnitude, What are the magnitudes of forces?

A. 12,6

B. 14,4

C. 5,13

D. 10,8

**Answer: C**



**Watch Video Solution**

91. A vector  $\vec{a}$  is turned without a change in its length through a small angle  $d\theta$ . Find the value of  $|\Delta \vec{a}|$

A. 0

B.  $a \cdot d\theta$

C. 0

D. None of these

**Answer: B**



**Watch Video Solution**

92. A force  $F = -k\hat{i} + x\hat{j}$  where  $k$  is a positive constant, acts on a particle moving in the  $xy$  plane. Starting from the origin, the particle is taken along the positive  $x$  - axis to the point  $(a,0)$  and then parallel to the  $y$ -axis to the point  $(a,a)$  the total work done by the force on the particle is

A.  $-2Ka^2$

B.  $2Ka^2$

C.  $-Ka^2$

D.  $Ka^2$

**Answer: C**



**Watch Video Solution**

93. For the figure shown

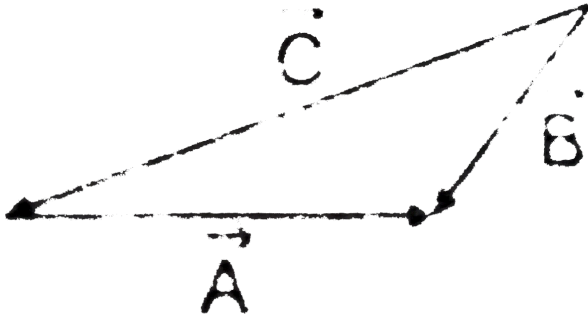

A.  $X = A + B - C + D$

B.  $Y = B + C - A$

C.  $Z = B + C$

D.  $W = A + B$

**Answer: B,C**



Watch Video Solution

94. If  $a$  and  $b$  are two vectors, then the value of

$(a + b) \times (a - b)$  is

A.  $2(b \times a)$

B.  $-2(b \times a)$

C.  $b \times a$

D.  $b \times a$

**Answer: A**



Watch Video Solution



95. Given that  $\vec{A} + \vec{B} = \vec{C}$  and that  $\vec{C}$  is perpendicular to  $\vec{A}$ . Further if  $|\vec{A}| = |\vec{C}|$ , then what is the angle between  $\vec{A}$  and  $\vec{B}$

A.  $\frac{\pi}{4}$

B.  $\frac{\pi}{2}$

C.  $\frac{3\pi}{4}$

D.  $\pi$

**Answer: C**



**Watch Video Solution**

96. The resultant of two forces, one double the other in magnitude, is perpendicular to the smaller of the two forces. The angle between the two forces is

A.  $120^\circ$

B.  $135^\circ$

C.  $90^\circ$

D.  $150^\circ$

**Answer: A**



**Watch Video Solution**

97. If  $A + B = C$ ,  $|A| = 2|B|$  and  $B \cdot C = 0$ , then

A.  $|A + B| = |A + B|$

B.  $|A + C| = B$

C.  $A \cdot B < 0$

D.  $A \cdot C$  may be zero

**Answer: C**



**Watch Video Solution**

98. Two unit vector when added give a unit vector .

Then choose the correct statement.

A. magnitude of their difference is  $\sqrt{3}$

B. Magnitude of their difference is 1

C. Angle between the vectors is  $90^\circ$

D. Angle between the sum and the difference of the two vectors is  $90^\circ$

**Answer: D,A**



**Watch Video Solution**

**99.** Which one of the following statement is true?

A. A scalar quantity is the one that is conserved In a process

B. A scalar quantity is the one that can never take negative values

C. A scalar quantity is the one that does not vary from one point to another in space

D. A scalar quantity has the same value for observers with different orientation of the axes.

**Answer: D**



**Watch Video Solution**

**100.** Figure shows the orientation of two vectors  $u$  and  $v$  in the  $XY$  plane.

if  $\vec{u} = a\hat{i} + b\hat{j}$  and  $\vec{v} = p\hat{i} + q\hat{j}$

which of the following is correct?

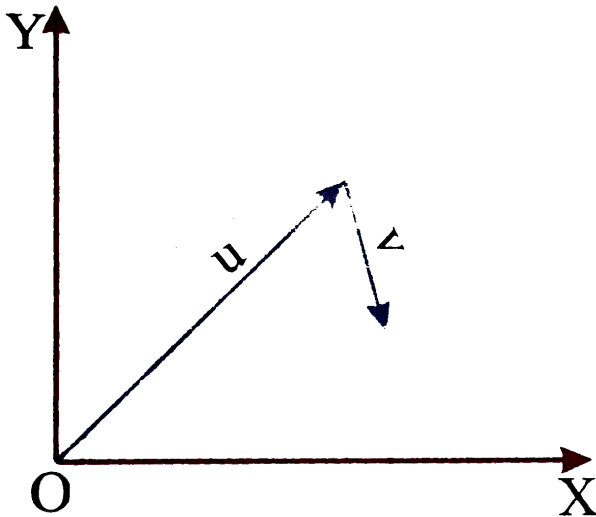

- A. a and p are positive while b and q are negative
- B. a, p and b are positive while q is negative
- C. a, q and b are positive while p is negative
- D. a, b, p and q are all positive

**Answer: B**



**Watch Video Solution**

**101.** The velocity of a particle is  $v = 6\hat{i} + 2\hat{j} - 2\hat{k}$  The component of the velocity parallel to vector  $a = \hat{i} + \hat{j} + \hat{k}$  in vector form is

A.  $6\hat{i} + 2\hat{j} + 2\hat{k}$

B.  $2\hat{i} + 2\hat{j} + 2\hat{k}$

C.  $\hat{i} + \hat{j} + \hat{k}$

D.  $6\hat{i} + 2\hat{j} + 2\hat{k}$

**Answer: B**



Watch Video Solution

102. The resultant  $R$  of vector  $P$  and  $Q$  is perpendicular to  $P$  and  $R=P$  both, then angle between  $|P|$  and  $|Q|$  is

A.  $45^\circ$

B.  $135^\circ$

C.  $120^\circ$

D. All of these

Answer: B



Watch Video Solution



103.

The

value

of

$$\hat{i} \times (\hat{i} \times a) + \hat{j} \times (\hat{j} \times a) + \hat{k} \times (\hat{k} \times a) \text{ is}$$

A.  $a$ B.  $a \times \hat{k}$ C.  $-2a$ D.  $-a$ **Answer: C****Watch Video Solution**

104. What is the angle between  $\vec{P}$  and the resultant of  $(\vec{P} + \vec{Q})$  and  $(\vec{P} - \vec{Q})$ ?

A. zero

B.  $\tan^{-1}(p/Q)$

C.  $\tan^{-1}(Q/p)$

D.  $\tan^{-1}(P - Q)/(P + Q)$

**Answer: A**



**Watch Video Solution**

**105.** If  $a_1$  and  $a_2$  are two non-collinear unit vectors and if  $|a_1 + a_2| = \sqrt{3}$ , then value of  $(a_1 - a_2) \cdot (2a_1 - a_2)$  is

A. 2

B.  $\frac{3}{2}$

C.  $\frac{1}{2}$

D. 1

**Answer: B**



**Watch Video Solution**

**106.** There are  $n$  coplanar vectors each of magnitude  $m$  and each vector is inclined to the preceding vector at an angle  $2\pi/n$ . Then the magnitude of their resultant is

A.  $\frac{V}{N}$

B.  $V$

C. zero

D.  $\frac{N}{V}$

**Answer: C**



**Watch Video Solution**

**107.** Three equal masses of 1 kg each are placed at the vertices of an equilateral triangle and other particle of mass 2kg is placed on centroid of triangle which is at a distance of  $\sqrt{2}$  m from each of the vertices of the triangle .The force in newton , acting on the particle of mass 2 kg is

A. 2

B. 1

C. 1

D. Zero

**Answer: D**



**Watch Video Solution**

**108.** At what angle must the two forces  $(x+y)$  and  $(x-y)$  act so that the resultant may be  $\sqrt{x^2 + y^2}$  ?

A.  $\cos^{-1} \left[ -\frac{x^2 + y^2}{2(x^2 - y^2)} \right]$

B.  $\cos^{-1} \left[ -\frac{-2x^2 - y^2}{(x^2 + y^2)} \right]$

C.  $\cos^{-1} \left[ -\frac{x^2 + y^2}{(x^2 - y^2)} \right]$

D.  $\cos^{-1} \left[ -\frac{x^2 - y^2}{(x^2 + y^2)} \right]$

**Answer: A**



**Watch Video Solution**

## Assertion And Reason

1. Assertion ( $A$ ): Galvanized iron is protected from Rusting.

Reason ( $R$ ):  $Zn$  is less reactive than  $Fe$ .

(a) If both ( $A$ ) and ( $R$ ) are correct, and ( $R$ ) is the correct explanation of ( $A$ ).

(b) If both  $(A)$  and  $(R)$  are correct, but  $(R)$  is not the correct explanation of  $(A)$ .

(c) If  $(A)$  is correct, but  $(R)$  is incorrect.

(d) If  $(A)$  is incorrect,  $(R)$  is correct.

A. If both Assertion and Reason are correct but Reason is the correct explanation of Assertion.

B. If both Assertion and Reason are correct but Reason is not the correct explanation of Assertion.

C. If Assertion is true but Reason is false

D. If Assertion is false but Reason is true

**Answer: A**

---



Watch Video Solution

2. Assertion ( $A$ ):  $Cu$  gets readily corroded in acidic aqueous solution.

Reason ( $R$ ): Free energy of the process is positive.

(a) If both ( $A$ ) and ( $R$ ) are correct, and ( $R$ ) is the correct explanation of ( $A$ ).

(b) If both ( $A$ ) and ( $R$ ) are correct, but ( $R$ ) is not the correct explanation of ( $A$ ).

(c) If ( $A$ ) is correct, but ( $R$ ) is incorrect.

(d) If both ( $A$ ) and ( $R$ ) are incorrect.

A. If both Assertion and Reason are correct but

Reason is the correct explanation of Assertion.



B. If both Assertion and Reason are correct but Reason is not the correct explanation of Assertion.

C. If Assertion is true but Reason is false

D. If Assertion is false but Reason is true

**Answer: C**



**Watch Video Solution**

3. Assertion - Vector addition of two vector is always greater than their vector subtraction.

Reason At  $\theta = 90^\circ$  , addition and subtraction of two vector are equal .

A. If both Assertion and Reason are correct but

Reason is the correct explanation of Assertion.

B. If both Assertion and Reason are correct but

Reason is not the correct explanation of

Assertion.

C. If Assertion is true but Reason is false

D. If Assertion is false but Reason is true

**Answer: D**



**Watch Video Solution**

4. Assertion -Magnitude of vector product of two vectors may be greater than , equal to or less than the scalar product .

Reason At  $\theta = 45^\circ$  two are equal .

A. (A) If both Assertion and Reason are correct but

Reason is the correct explanation of Assertion.

B. (B) If both Assertion and Reason are correct but

Reason is not the correct explanation of

Assertion.

C. (C) If Assertion is true but Reason is false

D. (D) If Assertion is false but Reason is true

Answer: B



Watch Video Solution

5. Assertion: Angle between  $\hat{i} + \hat{j}$  and  $\hat{i}$  is  $45^\circ$ .

Reason:  $\hat{i} + \hat{j}$  is equally inclined to both  $\hat{i}$  and  $\hat{j}$  and the angle between  $\hat{i}$  and  $\hat{j}$  is  $90^\circ$ .

A. If both Assertion and Reason are correct but

Reason is the correct explanation of Assertion.

B. If both Assertion and Reason are correct but

Reason is not the correct explanation of

Assertion.

C. If Asserion is true but Reason is false

D. If Asserion is false but Reason is true

**Answer: B**



**Watch Video Solution**

6. On a frictionless horizontal surface , assumed to be the  $x - y$  plane , a small trolley  $A$  is moving along a straight line parallel to the  $y -$  axis ( see figure) with a constant velocity of  $(\sqrt{3} - 1)m/s$  . At a particular instant , when the line  $OA$  makes an angle of  $45^\circ$  with the  $x -$  axis , a ball is thrown along the surface from the origin  $O$ . Its velocity makes an angle  $\phi$  with

the  $x$  – axis and it hits the trolley .

(a) The motion of the ball is observed from the frame of the trolley . Calculate the angle  $\theta$  made by the velocity vector of the ball with the  $x$  – axis in this frame .

(b) Find the speed of the ball with respect to the surface , if  $\phi = (4\theta) / (3)$ .

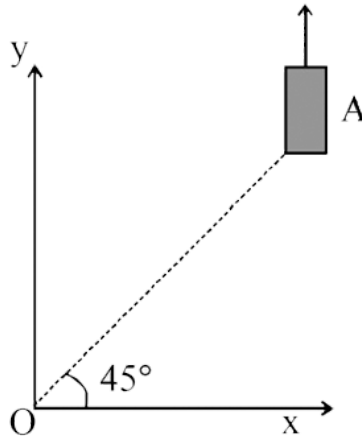

A. If both Assertion and Reason are correct but

Reason is the correct explanation of Assertion.

B. If both Assertion and Reason are correct but Reason is not the correct explanation of Assertion.

C. If Assertion is true but Reason is false

D. If Assertion is false but Reason is true

**Answer: D**



**Watch Video Solution**

7. Assertion - Component of A along B is equal to component of B along A.

Reason value of component is always less than the magnitude of vector .

A. If both Assertion and Reason are correct but

Reason is the correct explanation of Assertion.

B. If both Assertion and Reason are correct but

Reason is not the correct explanation of

Assertion.

C. If Assertion is true but Reason is false

D. If Assertion is false but Reason is true

**Answer: D**



**Watch Video Solution**



8. Assertion  $(A+B)(A-B)$  is always positive.

Reason this is positive if  $|A| > |B|$

A. If both Assertion and Reason are correct but

Reason is the correct explanation of Assertion.

B. If both Assertion and Reason are correct but

Reason is not the correct explanation of

Assertion.

C. If Assertion is true but Reason is false

D. If Assertion is false but Reason is true

**Answer: D**



**Watch Video Solution**

9. Assertion:  $\vec{A} \times \vec{B}$  is perpendicular to both  $\vec{A} - \vec{B}$  as well as  $\vec{A} + \vec{B}$

Reason:  $\vec{A} + \vec{B}$  as well as  $\vec{A} - \vec{B}$  lie in the plane containing  $\vec{A}$  and  $\vec{B}$ , but  $\vec{A} \times \vec{B}$  lies perpendicular to the plane containing  $\vec{A}$  and  $\vec{B}$ .

A. If both Assertion and Reason are correct but

Reason is the correct explanation of Assertion.

B. If both Assertion and Reason are correct but

Reason is not the correct explanation of Assertion.

C. If Assertion is true but Reason is false

D. If Assertion is false but Reason is true

**Answer: A**

 [Watch Video Solution](#)

**10.** Assertion If angle between  $a$  and  $b$  is  $30^\circ$ . Then angle between  $2a$  and  $-\frac{b}{2}$  will be  $150^\circ$

Reason Sign of dot product of two vectors tells you whether angle between two vectors is acute or obtuse.

A. If both Assertion and Reason are correct but

Reason is the correct explanation of Assertion.

B. If both Assertion and Reason are correct but Reason is not the correct explanation of Assertion.

C. If Assertion is true but Reason is false

D. If Assertion is false but Reason is true

**Answer: B**



**Watch Video Solution**

11. Assertion -  $(A \times B) \cdot (B \times A)$  is  $-a^2 B^2 \sin^2 \theta$  Here  $\theta$  is the angle between A and B.

Reason  $(A \times B)$  and  $(B \times A)$  are two anti-parallel

vectors provided A and B are neither parallel nor anti - parallel .

A. If both Assertion and Reason are correct but Reason is the correct explanation of Assertion.

B. If both Assertion and Reason are correct but Reason is not the correct explanation of Assertion.

C. If Assertion is true but Reason is false

D. If Assertion is false but Reason is true

**Answer: B**



**Watch Video Solution**

12. Assertion - If  $|A| = |B|$ , then  $(A + B)$ ,  $(A - B)$  and  $(A \times B)$  are three mutually perpendicular vectors .

Reason - Dot Product of a null vector with any other vector is always zero .

A. If both Assertion and Reason are correct but

Reason is the correct explanation of Assertion.

B. If both Assertion and Reason are correct but

Reason is not the correct explanation of

Assertion.

C. If Assertion is true but Reason is false

D. If Assertion is false but Reason is true

**Answer: B**



**Watch Video Solution**

13. If  $\vec{a}$  and  $\vec{b}$  are two unit vectors and  $\theta$  is the angle between them, then the unit vector along the angular bisector of  $\vec{a}$  and  $\vec{b}$  will be given by

A. If both Assertion and Reason are correct but

Reason is the correct explanation of Assertion.

B. If both Assertion and Reason are correct but

Reason is not the correct explanation of

Assertion.

C. If Assertion is true but Reason is false

D. If Assertion is false but Reason is true

**Answer: C**



**Watch Video Solution**

**14.** Assertion - If  $\theta$  be the angle between  $A$  and  $B$  then

$$\tan \theta = \frac{A \times B}{AB}$$

Reason -  $A \times B$  is perpendicular to  $AB$ .

A. If both Assertion and Reason are correct but

Reason is the correct explanation of Assertion.



B. If both Assertion and Reason are correct but Reason is not the correct explanation of Assertion.

C. If Assertion is true but Reason is false

D. If both Assertion and Reason are false.

**Answer: D**



**Watch Video Solution**

**Match The Columns**

1. For component of a vector  $A = (3\hat{i} + 4\hat{j} - 5\hat{k})$ ,

match the following table

Table-1	Table-2
(A) Along y-axis	(P) 5 unit
(B) Along another vector $(2\hat{i} + \hat{j} + 2\hat{k})$	(Q) 4 unit
(C) Along $(6\hat{i} + 8\hat{j} - 10\hat{k})$	(R) Zero
(D) Along another vector $(-3\hat{i} - 4\hat{j} + 5\hat{k})$	(S) None



[Watch Video Solution](#)

2. Two vector A and B have rqual magnitude x .Angle between tjem is  $60^\circ$  Then match the following two

columns.

Column I

Column II

- |                    |                             |
|--------------------|-----------------------------|
| (A) $ A+B $        | (P) $\frac{\sqrt{3}}{2}x^2$ |
| (B) $ A - B $      | (Q) $x$                     |
| (C) $A \cdot B$    | (r) $\sqrt{3}x$             |
| (D) $ A \times B $ | (s) None                    |



Watch Video Solution

3. Vector A is pointing eastwards and vector B northwards .if  $|A| = |B|$  then match the following two columns.

Column I

Column II

- |  |                        |
|--|------------------------|
| (A) $(A + B)$                          | (P) north -east        |
| (B) $(A - B)$                          | (Q) Vertically upwards |
| (C) $(A \times B)$                     | (r) south-east         |
| (D) $(A \times B) \times (A \times B)$ | (s) None               |



Watch Video Solution

4. A vector has a magnitude  $x$  . If it is rotated by an angle  $\theta$  then magnitude of change in vector is  $nx$ .

Match the following two columns.

Column I

Column II

(A)  $\theta = 60^\circ$

(P)  $n = \sqrt{3}$

(B)  $\theta = 90^\circ$

(Q)  $n = 1$

(C)  $\theta = 120^\circ$

(R)  $n = \sqrt{2}$

(D)  $\theta = 180^\circ$

(S)  $n = 2$



[Watch Video Solution](#)

5. If  $\theta$  is the angle between two vectors A and B , then match the following two columns.

Column I

Column II

(A)  $A \cdot B = |A \times B|$

(P)  $\theta = 90^\circ$

(B)  $A \cdot B = B^2$

(Q)  $\theta = 0^\circ$  or  $180^\circ$

(C)  $|A + B| = |A - C|$

(r)  $A = B$

(D)  $|A \times B| = AB$

(s) None



Watch Video Solution

## Medical Enrances Gallery

1. If the magnitude of sum of two vectors is equal to the magnitude of difference of the two vector, the angle between these Vector is

A.  $90^\circ$

B.  $45^\circ$

C.  $180^\circ$

D.  $0^\circ$

**Answer: A**



**Watch Video Solution**

2. If a vector  $2\hat{i} + 3\hat{j} + 8\hat{k}$  is perpendicular to the vector  $4\hat{i} - 4\hat{j} + \alpha\hat{k}$ , then the value of  $\alpha$  is

A.  $1/2$

B.  $-1$

C.  $-1/2$

D.  $1$

**Answer: C**



**Watch Video Solution**

3. The angle  $\theta$  between the vector  $p = \hat{i} + \hat{j} + \hat{k}$  and unit vector along X-axis is

A.  $\cos^{-1}\left(\frac{1}{\sqrt{3}}\right)$

B.  $\cos^{-1}\left(\frac{1}{\sqrt{2}}\right)$

C.  $\cos^{-1}\left(\frac{\sqrt{3}}{2}\right)$

D.  $\cos^{-1}\left(\frac{1}{2}\right)$

**Answer: A**



**Watch Video Solution**

4. Consider three vectors  $A = \hat{i} + \hat{j} - 2\hat{k}$ ,

$B = \hat{i} + \hat{j} + 2\hat{k}$  and  $2\hat{i} - 3\hat{j} + 4\hat{k}$  A vector X of the

from  $\alpha A + \beta B$  ( $\alpha$  and  $\beta$  are numbers) is

perpendicular to C. The ratio of  $\alpha$  and  $\beta$  is

A. 1:1

B. 2:1

C. -1:1

D. 3:1

**Answer: A**



Watch Video Solution



5. Two equal vector have a resultant equal to either of them, then the angle between them will be:

A.  $90^\circ$

B.  $60^\circ$

C.  $120^\circ$

D.  $0^\circ$

**Answer: C**



**Watch Video Solution**

6. Which of the following is not a cloning vector ?

A. Weight

B. Nuclear spin

C. Momentum

D. Potential energy

**Answer: D**



**Watch Video Solution**

7. The scalar product of two vectors

$A = 2\hat{i} + 2\hat{j} - \hat{k}$  and  $B = -\hat{j} + \hat{k}$ , is given by

A.  $A \cdot B = 3$

B.  $A \cdot B = 4$

C.  $A \cdot B = -4$

D.  $A \cdot B = -3$

**Answer: D**



**Watch Video Solution**

**8.** If  $A \cdot B = A \times B$ , then angle between  $A$  and  $B$  is

A.  $45^\circ$

B.  $30^\circ$

C.  $60^\circ$

D.  $90^\circ$

Answer: A



Watch Video Solution

9. A vector  $\vec{B}$  which has a magnitude 8.0 is added to a vector  $\vec{A}$  which lies along the x-axis. The sum of these two vector is a third vector which lies along the y-axis and has a magnitude that is twice the magnitude of  $\vec{A}$ .

Find the magnitude of  $\vec{A}$

A.  $\frac{6}{\sqrt{5}}$

B.  $\frac{12}{\sqrt{5}}$

C.  $\frac{16}{\sqrt{5}}$

D.  $\frac{8}{\sqrt{5}}$

**Answer: D**



**Watch Video Solution**