



## PHYSICS

### BOOKS - DC PANDEY ENGLISH

### WORK, ENERGY AND POWER

#### Example

1. A gas filled in a cylinder fitted with movable piston is allowed to expand. What is the nature of the work done by the gas?



[Watch Video Solution](#)

2. A lawn roller has been pushed by a gardener through a distance of 30 m. What will be the work done by him, if he applies a force of 30 kg-wt in the direction inclined at  $60^\circ$  to the ground?



[Watch Video Solution](#)

3. A rigid body moves a distance of 10m along a straight line under the action of a force 5N. If the work done by this force on the body is 25 joules, the angle which the force makes with the force makes with the direction of motion of the body is:



[Watch Video Solution](#)

4. A block of mass  $m = 2\text{kg}$  is pulled by a force  $F = 40\text{N}$  upwards through a height  $h = 2\text{m}$ . Find the work done on the block by the applied force  $F$  and its weight  $mg$ . ( $g = 10\text{m/s}^2$ ).

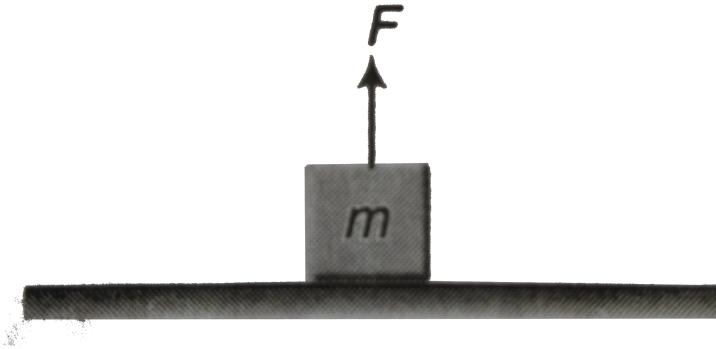

[Watch Video Solution](#)

5. A  $10\text{g}$  block placed on a rough horizontal floor is being pulled by a constant force  $50\text{N}$ . Coefficient of kinetic friction between the block and the floor is  $0.4$ . Find work done by each individual

force acting on the block over displacement of 5 m.

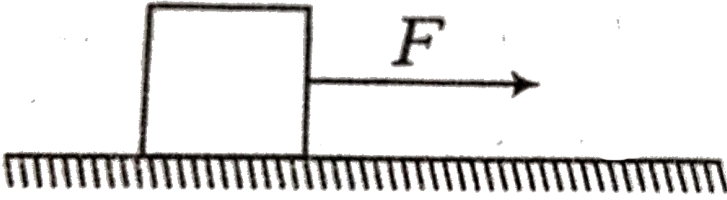

[▶ Watch Video Solution](#)

6. A block of mass 2 kg is being brought down by a string. If the block acquires a speed  $1(m)/(s)$  in dropping down 25 cm, find the work done by the string in the process.

[▶ Watch Video Solution](#)

7. Two unequal masses of 1 kg and 2 kg are attached at the two ends of a light inextensible string passing over a smooth pulley

as shown in figure. If the system is released from rest, find the work done by string on both the blocks in 1 s. (Take  $g = 10 \text{ m.s}^{-2}$ )

)

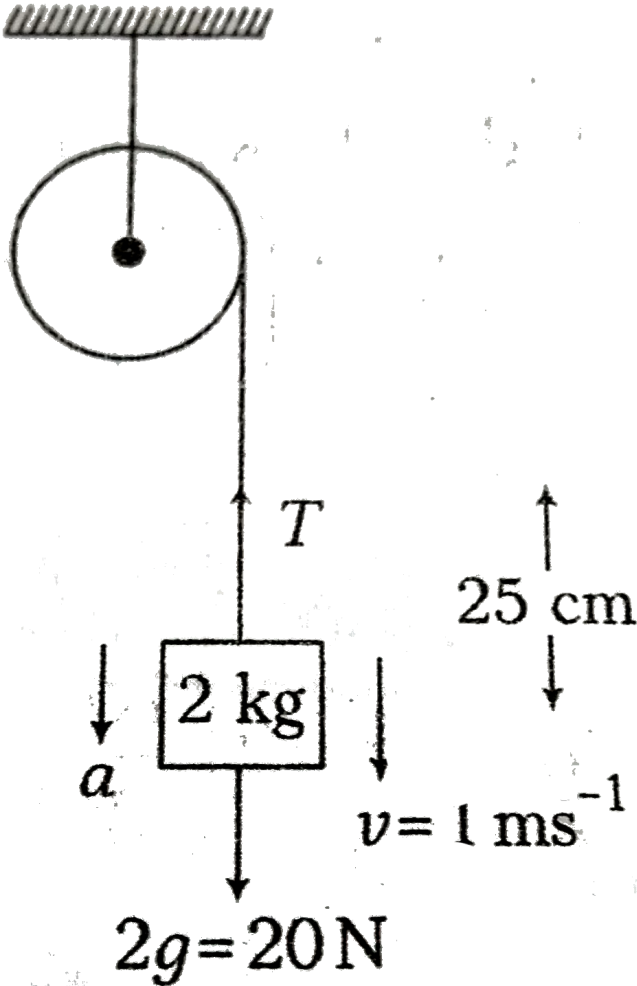

Watch Video Solution

8. A constant force  $F = (\hat{i} + 3\hat{j} + 4\hat{k}) N$  acts on a particle and displace it from  $(-1m, 2m, 1m)$  to  $(2m, -3m, 1m)$ .



[Watch Video Solution](#)

9. A particle is shifted from point  $(0, 0, 1m)$  to  $(1m, 1m, 2m)$ , under simultaneous action of several forces. Two of the forces are  $F_1 = (2\hat{i} + 3\hat{j} - \hat{k}) N$  and  $F_2 = (\hat{i} - 2\hat{j} + 2\hat{k}) N$ . Find work done by resultant of these two forces.



[Watch Video Solution](#)

10. A position dependent force

$$F = (7 - 2x + 3x^2) N,$$

acts on a small body of mass 2kg and displaces it from  $x = 0$  to  $x = 5m$ . Work done in joule is



[Watch Video Solution](#)

11. A force  $F = (2 + x)$  acts on a particle in x-direction where F is in newton and x in metre. Find the work done by this force during a displacement form 1.0 m to  $x = 2.0$  m.



[Watch Video Solution](#)

12. A force  $F = -\frac{k}{x^2}$  ( $x \neq 0$ ) acts on a particle in x-direction. Find the work done by this force in displacing the particle from.  $x = +a$  to  $x = 2a$ . Here, k is a positive constant.



[Watch Video Solution](#)

13. Force  $F$  on a particle moving in a straight line varies with distance  $d$  as shown in the figure. The work done on the particle during its displacement of  $12m$  is

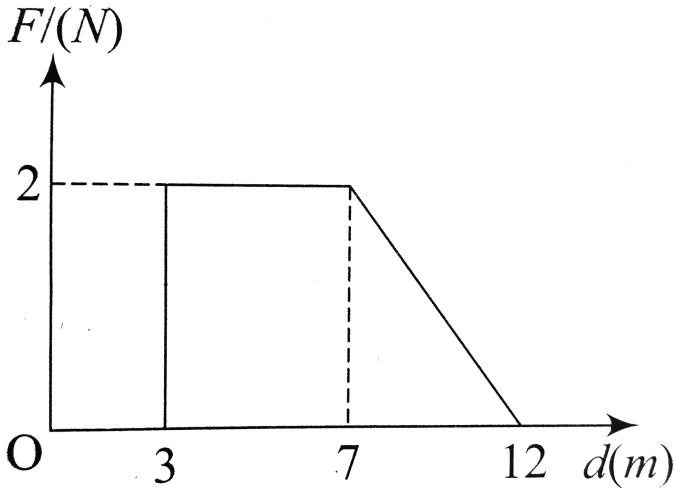

[Watch Video Solution](#)

14. The relationship between force and position is shown in fig ( in one dimensional case). The work done in displacing a body



from  $x=1\text{cm}$  to  $x = 5 \text{ cm}$  is:

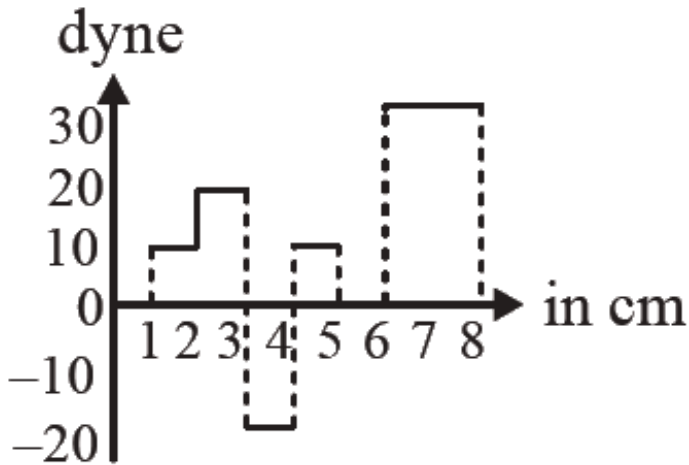

[Watch Video Solution](#)

**15.** A force  $F$  acting on a particle varies with the position  $x$  as shown in figure. Find the work done by this force in displacing

the

particle

from

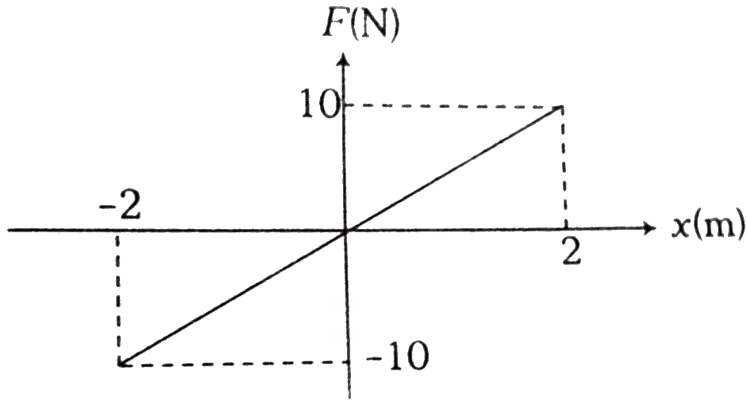

[▶ Watch Video Solution](#)

16. The work done in extending a spring by  $x_0$  is  $W_0$ . Find the work done in further extension  $x_0$ .

[▶ Watch Video Solution](#)

17. Consider a block connected to a light spring of spring constant  $100Nm^{-1}$ . Now the block is displaced by applying a

constant force  $F$  which gives zero resultant force when spring is stretched through 10 cm.

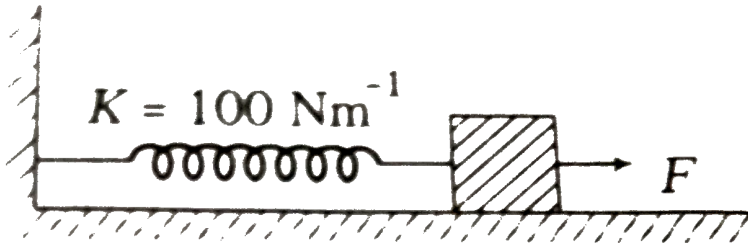

Evaluate

- (i) Work done by the spring force when the block attains equilibrium.
- (ii) Net work done on the block when it attains maximum speed.



[Watch Video Solution](#)

**18.** A train is moving with a speed of  $90 \text{ kmh}^{-1}$  passenger X inside the train displaces his 40 kg, luggage slowly on the floor through 1 m in 10 s. Coefficient of friction of the floor of the train is 0.2. Find the work done by this passenger X and the

luggage as seen by

(i) a follow passenger Y

(ii) a person on the ground [Take , $g=10 \text{ ms}^{-1}$ ].

 [Watch Video Solution](#)

**19.** An object is displaced from point A(2m,3m,4m,) to a point B (1m,2m,3m) under a constant force  $(2\hat{i} + 3\hat{j} + 4\hat{k})$  N. Find the work done by this force in this process.

 [Watch Video Solution](#)

**20.** An object is displaced from positin vector  $r_1 = (2\hat{i} + 3\hat{j})$  m to  $r_2 = (4\hat{i} + 6\hat{j})$  m under a forc  $F = (3x^2\hat{i} + 2y\hat{j})N$  Find the work done by this force.

 [Watch Video Solution](#)

21. A body of mass 0.3 kg is taken up an inclined plane of length 10 m and height 5 m, and then allowed to slide down the bottom again. The coefficient of friction between the body and the plane is 0.15. What is the

(i) work done by the applied force over the upward journey?

(ii) work done by gravitational force over the round trip?

(iii) work done by the frictional force over the round trip?

Which of the above forces (except applied force) is/are conservative forces?

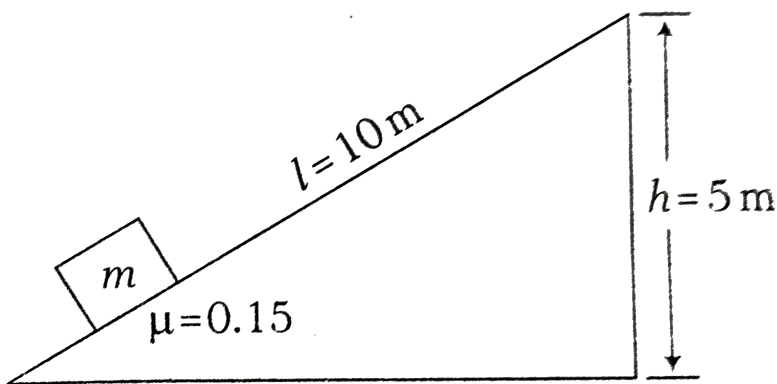

 Watch Video Solution

22. If a man increase his speed by  $2\text{m/s}$ , his K.E. is doubled, the original speed of the man is

 [Watch Video Solution](#)

23. In a ballistics demonstration, a police officer fires a bullet mass  $50.0\text{g}$  with speed  $200\text{ms}^{-1}$  on soft plywood of thickness  $2.00\text{cm}$ . The bullet emerges only with  $10\%$  of its initial kinetic energy. What is the emergent speed of the bullet ?

 [Watch Video Solution](#)

24. A body of mass  $0.8\text{ kg}$  has intial velocity  $(3\hat{i} - 4\hat{j})\text{ms}^{-1}$  and final velocity  $(-6\hat{j} + 2\hat{k})\text{ms}^{-1}$ . Find change in kinetic energy of the body?



[Watch Video Solution](#)

25. Two bodies A and B having masses in the ratio of 3 : 1 possess the same kinetic energy. The ratio of their linear momenta is then



[Watch Video Solution](#)

26. Kinetic energy of a particle is increased by 300 %. Find the percentage increase in momentum.



[Watch Video Solution](#)

27. The position ( $x$ ) of a particle of mass 1 kg moving along x-axis at time  $t$  is given by  $\left(x = \frac{1}{2}t^2\right)$  meter. Find the work done by

force acting on it in time interval from  $t=0$  to  $t=3$  s.



[Watch Video Solution](#)

**28.** A bullet weighing 10 g is fired with a velocity of  $800\text{ms}^{-1}$ . After passing through a mud wall 1 m thick, its velocity decreases to  $100\text{ms}^{-1}$ . Find the average resistance offered by the mud wall.



[Watch Video Solution](#)

**29.** An object of mass 5 kg falls from rest through a vertical distance of  $20\text{m}$  and attains a velocity of 10 m/s. How much work is done by the resistance of the air on the object?  
( $g = 10\text{m} / \text{s}^2$ ).



[Watch Video Solution](#)



**30.** A particle of mass  $m$  moves on a straight line with its velocity varying with the distance travelled according to the equation  $v = a\sqrt{x}$ , where  $a$  is a constant. Find the total work done by all the forces during a displacement from  $x = 0 \rightarrow x = d$ .



[Watch Video Solution](#)

**31.** A block of mass  $10\text{kg}$  is moving in  $x$ -direction with a constant speed of  $10\text{m/s}$ . It is subjected to a retarding force  $F = -0.1x\text{J/m}$ . During its travel from  $x = 20\text{m}$  to  $x = 30\text{m}$ . Its final kinetic energy will be .



[Watch Video Solution](#)

32. An object of mass  $m$  is tied to a string of length  $l$  and a variable force  $F$  is applied on it which brings the string gradually at angle  $\theta$  with the vertical. Find the work done by the force  $F$

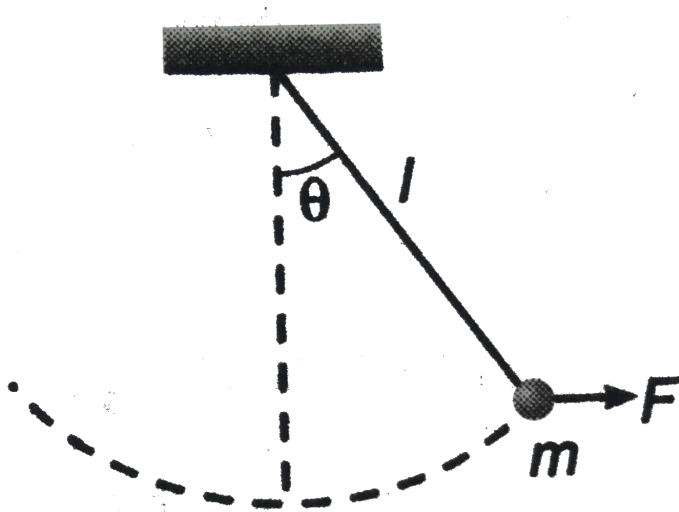

Watch Video Solution

33. A small ball is placed at the top of a smooth hemispherical wedge of radius  $R$ . If the wedge is accelerated with an

acceleration  $a$ , find the velocity of the ball relative to wedge as a function of  $\theta$ .

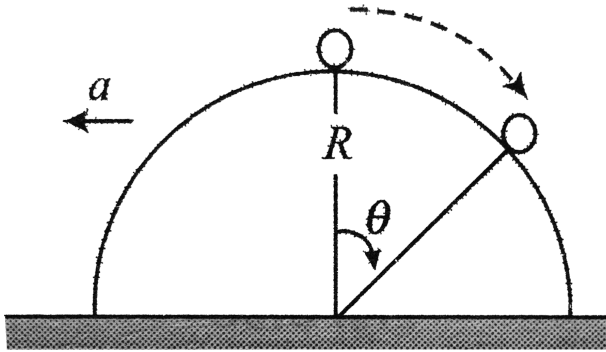

[Watch Video Solution](#)

**34.** A stone of mass  $0.4 \text{ kg}$  is thrown vertically up with a speed of  $9.8 \text{ ms}^{-1}$ . Find the potential energy after half second.

[Watch Video Solution](#)

**35.** Calculate the work done in lifting a 300N weight to a height of 10m with an acceleration  $0.5ms^{-2}$ . Take  $g=10ms^{-2}$ .



[Watch Video Solution](#)

**36.** Two springs with spring constants  $K_1 = 1500N/m$  and  $K_2 = 3000N/m$  are stretched by the same force. The ratio of potential energy stored in spring will be



[Watch Video Solution](#)

**37.** A block of mass 8 kg is released from the top of an inclined smooth surface as shown in figure. If spring constant of spring is  $200 Nm^{-1}$  and block comes to rest after compressing spring

by 1 m then find the distance travelled by block before it comes

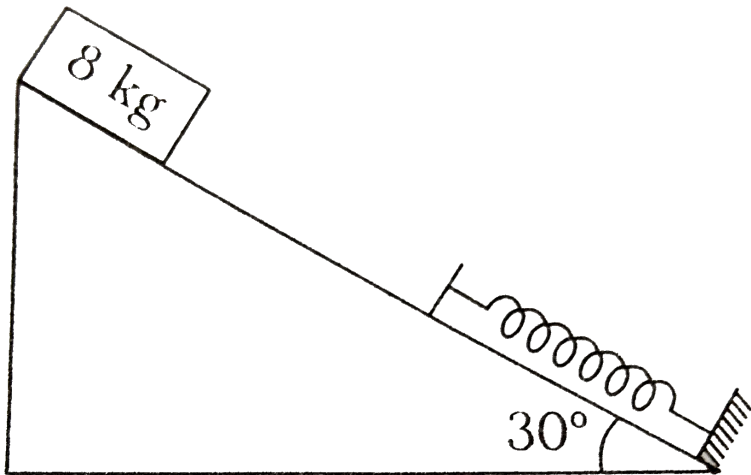

to rest

[Watch Video Solution](#)

**38.** Two cylindrical vessels of equal cross sectional area  $A$  contain water upto heights  $h_1$  and  $h_2$ . The vessels are interconnected so that the levels in them become equal. Calculate the work done by the force of gravity during the process. The density of water is  $\rho$

[Watch Video Solution](#)

**39.** A particle is moving on frictionless XY-plane. It is acted on by a conservative force described by the potential-energy function.

$$U(x, y, z) = \frac{1}{2}k(x^2 + y^2 + z^2)$$

where , k=constant

Derive an expression for the force on the particle.

 [Watch Video Solution](#)

**40.** A uniform chain of length 4m is kept on a table such that a length of 120 cm hangs freely from the edge of the table. The total mass of the chain is 4 kg What is the work done in pulling the entire chain on the table ?

 [Watch Video Solution](#)

**41.** The potential energy of a conservative force field is given by

$$U = ax^2 - bx$$

where, a and b are positive constants. Find the equilibrium position and discuss whether the equilibrium is stable, unstable or neutral.



[Watch Video Solution](#)

**42.** The potential energy for a conservative force system is given by  $U = ax^2 - bx$ . Where a and b are constants find out (a) The expression of force (b) Potential energy at equilibrium.



[Watch Video Solution](#)

**43.** A body of mass 5 kg is thrown vertically up with a kinetic energy of 490 J. What will be height at which the kinetic energy of the body becomes half of the original value ? (Acceleration due to gravity =  $9.8ms^{-2}$ )



**Watch Video Solution**

**44.** A bullet of mass  $m$  moving with velocity  $v_1$  strikes a suspended wooden block of mass  $M$  as shown in the figure and sticks to it. If the block rises to a height  $y$ . the initial of the bullet



is

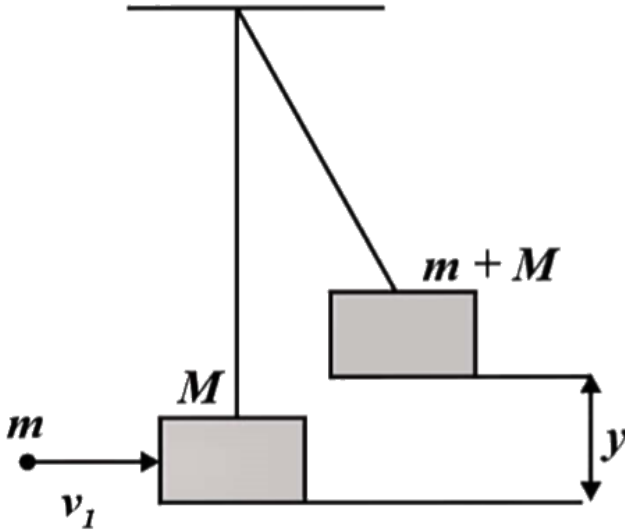

Watch Video Solution

**45.** A particle of mass  $m$  makes SHM in a smooth hemispherical bowl ABC and it moves from A to C and back to A via ABC, so that

$PB=h$ . Find the speed of the ball when it just crosses the point B.

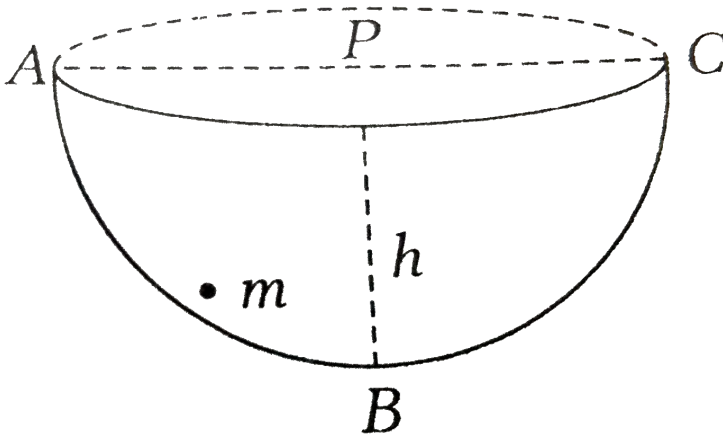

[Watch Video Solution](#)

46. A child is swinging a swing. Minimum and maximum heights fo swing from the earth's surface are 0.75 m and 2 m respectively. The maximum velocity of this swing is

[Watch Video Solution](#)

47. A machine which is 75 percent efficient, uses 12 joules of energy in lifting up a 1 kg mass through a certain distance. The mass is then allowed to fall through that distance. The velocity at the end of its fall is (in  $ms^{-1}$ )

 [Watch Video Solution](#)

48. Auto manufactures study the collision of cars with mounted spring of different spring constant. Consider a car of mass 1500 kg moving with a speed of  $36kmh^{-1}$  on a smooth road and colliding with a horizontally mounted spring of spring constant  $7.5 \times 10^3 Nm^{-1}$ . Find the maximum compression of the spring .

 [Watch Video Solution](#)

**49.** A spherical ball of mass  $20\text{kg}$  is stationary at the top of a hill of height  $100\text{m}$ , it rolls down a smooth surface to the ground, then climbs up another bill of height of  $30\text{m}$  and finally rolls down to a horizontal base at a height of  $20\text{m}$  about the ground. The velocity attained by the ball is



**Watch Video Solution**

**50.** A smooth narrow tube in the form of an arc  $AB$  of a circle of centre  $O$  and radius  $r$  is fixed so that  $A$  is vertically above  $O$  and  $OB$  is horizontal. Particles  $P$  of mass  $m$  and  $Q$  of mass  $2m$  with a light inextensible string of length  $(\pi r/2)$  connecting them are placed inside the tube with  $P$  at  $A$  and  $Q$  at  $B$  and released from rest. Assuming the string remains taut during motion, find the

speed of particles when P reaches B.

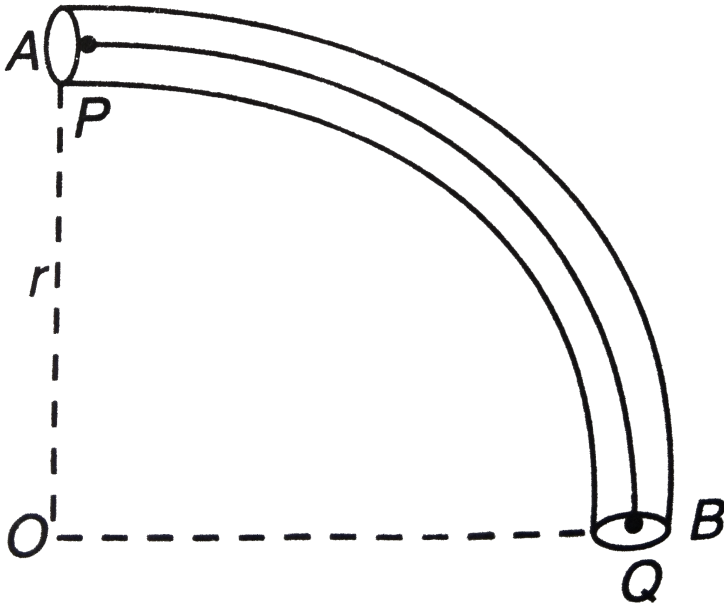

[Watch Video Solution](#)

51. In the arrangement shown in figure, string is light and inextensible and friction is absent everywhere. The speed of both blocks after the block 'A' has ascended a height of  $1m$  will

be ( $g = 10\text{ m/s}^2$ )

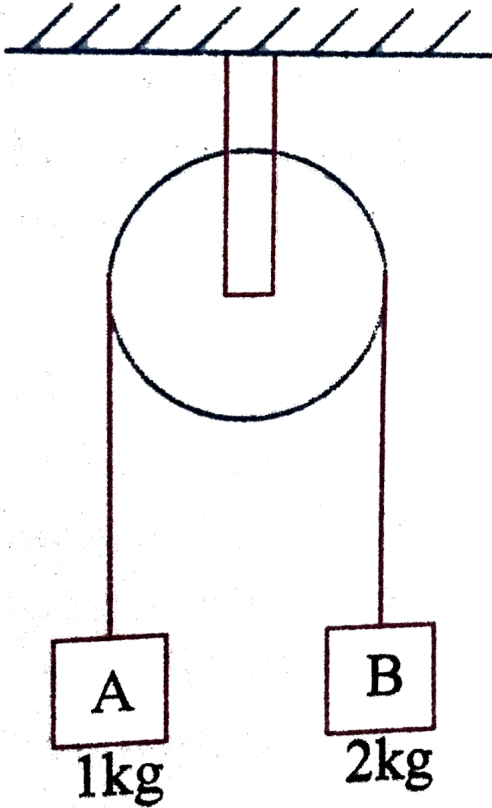

Watch Video Solution

52. In the arrangement shown in figure,  $m_A=1\text{ kg}$ ,  $m_B=4\text{ kg}$ . String is light and inextensible while pulley is smooth. Coefficient of friction between block A and the table is  $\mu=0.2$ . Find the speed

of both the blocks when block B has descended a height  $h=1$  m.

(Take  $g=10 \text{ m.s}^{-2}$ )

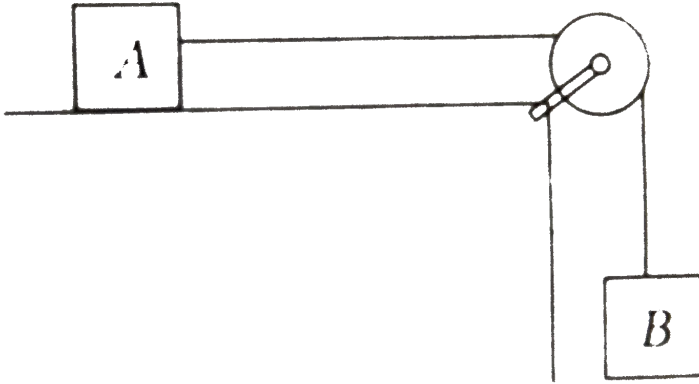

[▶ Watch Video Solution](#)

**53.** Consider the situation shown in figure. The system is released from rest and the block of mass  $1\text{kg}$  is found to have a speed  $0.3\text{m/s}$  after it has descended through a distance of  $1\text{m}$ . Find the coefficient of kinetic friction between the block and

the table.

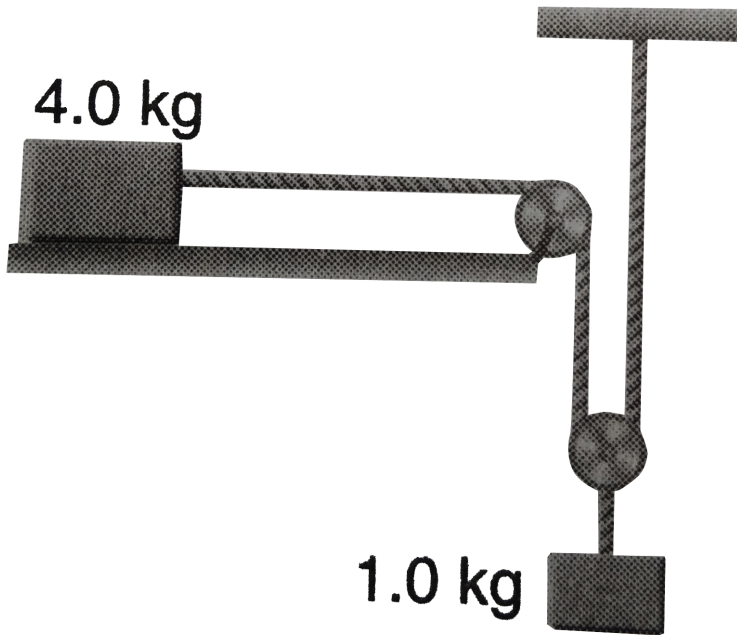

[Watch Video Solution](#)

**54.** A 20 kg body is released from rest so as to slide in between vertical rails and compresses a vertical spring  $\left(k = 1920 \frac{N}{m}\right)$  placed at a distance  $h = 1.0\text{m}$  from the starting position of the body. The rails offer a frictional force of 40 N opposing the motion of body. Find (a) the velocity  $v$  of the body just before



striking with the spring, (b) the maximum compression of the spring and (c) the distance  $h'$  through which the body is rebounded up.

 [Watch Video Solution](#)

**55.** Calculate the energy in MeV equivalent to the rest mass of an electron . Given that the rest mass of an electron ,  $m = 9.1 \times 10^{-31} \text{ kg}$ ,  $1 \text{ MeV} = 1.6 \times 10^{-13} \text{ J}$  and speed of light ,  $c = 3 \times 10^8 \text{ ms}^{-1}$ .

 [Watch Video Solution](#)

**56.** When slow neutrons are incident on a target containing

${}_{92}^{235}\text{U}$ , a possible fission reaction is

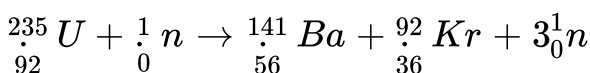

Estimate the amount of energy released using the following data Given, mass of  ${}_{92}^{235}\text{U} = 235.04\text{a}\mu$ , mass of  ${}_{0}^1\text{n} = 1.0087\text{a}\mu$ , mass of  ${}_{56}^{141}\text{Ba} = 140.91\text{a}\mu$ , mass of  ${}_{36}^{92}\text{Kr} = 91.926\text{a}\mu$ , and energy equivalent to  $1\text{amu}=931\text{MeV}$ .



[Watch Video Solution](#)

57. A train has a constant speed of  $40\text{ms}^{-1}$  on a level road against resistive force of magnitude  $3 \times 10^4\text{N}$ . Find the power of the engine.



[Watch Video Solution](#)

58. A machine gun fires 240 bullets per minute. If the mass of each bullet is 10 g and the velocity of the bullets is  $600\text{ms}^{-1}$ , then find power (in kW) of the gun.



[Watch Video Solution](#)

59. In unloading grain from the hold of a ship, an elevator lifts the grain through a distance of 12 m. Grain is discharged at the top of the elevator at a rate of 2 kg each second and the discharge speed of each of grain particle is  $3 \text{ ms}^{-1}$ . Find the minimum horsepower of the motor that can elevate grain in this way. (Take  $g=10 \text{ ms}^{-2}$ )



[Watch Video Solution](#)

60. A pump can take out 7200 kg of water per hour from a well 100 m. deep. The power of pump, assuming its efficiency as 50 % will be



[Watch Video Solution](#)

61. A block of mass  $m$  is pulled by a constant power  $P$  placed on a rough horizontal plane. The friction coefficient between the block and the surface is  $\mu$ . Maximum velocity of the block will be

 [Watch Video Solution](#)

62. The force required to row a boat at constant velocity is proportional to the speed. If a speed of  $4 \text{ kmh}^{-1}$  requires 7.5 kW, how much power does a speed of  $12 \text{ kmh}^{-1}$  require?

 [Watch Video Solution](#)

63. An engine pumps 400 kg of water through height of 10 m in 40 s. Find the power of the engine if its efficiency is 80% (Take  $g = 10 \text{ ms}^{-2}$ ).



 [Watch Video Solution](#)

**64.** An automobile of mass  $m$  accelerates from rest. If the engine supplies a constant power  $P$ , the velocity at time  $t$  is given by -

 [Watch Video Solution](#)

**65.** A train of mass  $2 \times 10^5$  kg has a constant speed of  $20 \text{ m s}^{-1}$  up a hill inclined at  $\theta = \sin^{-1}\left(\frac{1}{50}\right)$  to the horizontal when the engine is working at  $8 \times 10^5$  W. Find the resistance to motion of the train. (Take  $g=9.8 \text{ m s}^{-2}$ ).

 [Watch Video Solution](#)

**66.** A small body of mass  $m$  moving with velocity  $v_0$  on rough horizontal surface, finally stops due to friction. Find, the mean

power developed by the friction force during the motion of the body, if the frictional coefficient  $\mu=0.27$ ,  $m=1$  kg and  $v_0 = 1.5\text{ms}^{-1}$ .



[Watch Video Solution](#)

### Check Point 6 1

1. A gardener pushes a lawn roller through a distance of 20 m. If he applies a force of 20 kg wt in a direction inclined at  $60^\circ$  to the ground, find the work

- A. 1960 J
- B. 196 J
- C. 1.96 J
- D. 196 kJ

**Answer: A**



**Watch Video Solution**

2. How much work must work be done by a force on 50 kg body in order to accelerate it in the direction of force from rest to  $20ms^{-1}$  in 10 s?

A.  $10^{-3}J$

B.  $10^4 J$

C.  $2 \times 10^3 J$

D.  $4 \times 10^4 J$

**Answer: B**



**Watch Video Solution**

3. A horizontal force  $F$  pulls a 20 kg box at a constant speed along a rough horizontal floor. The coefficient of friction between the box and the floor is 0.25. The work done by force  $F$  on the block in displacing it by 2 m is

A. 49 J

B. 98 J

C. 147 J

D. 196 J

**Answer: B**



**Watch Video Solution**



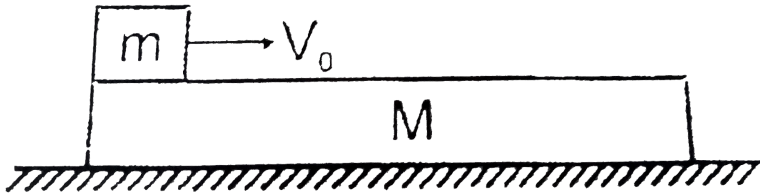

Smooth

4.

The block of mass  $m$  is kept on plank of mass  $M$ . The block is given velocity  $V_0$  as shown. The coefficient of friction between the block of mass  $m$  and plank of mass  $M$  is  $\mu$  and its value is such that block becomes stationary with respect to plank before it reaches the other end. Then:

- A. The work done by friction on the block is negative
- B. The work done by friction on the plank is positive
- C. The net work done by friction is negative
- D. Net work done by the friction is zero

**Answer: D**

 [Watch Video Solution](#)

5. A man pushes a wall and fails to displace it. He does

- A. negative work
- B. positive but not maximum work
- C. maximum positive work
- D. no work at all

**Answer: D**

 [Watch Video Solution](#)

6. The work done by kinetic friction on a body :

- A. is always negative

B. is always zero

C. may be negative or positive

D. is always positive

**Answer: C**



**Watch Video Solution**

7. A force  $(3\hat{i} + 4\hat{j})$  newton acts on a body and displaces it by  $(3\hat{i} + 4\hat{j})$  metre. The work done by the force is

A. 10 J

B. 12 J

C. 16 J

D. 25 J

**Answer: D**



**Watch Video Solution**

8. A force  $F = (2\hat{i} - \hat{j} + 4\hat{k})N$  displaces a particle upto  $d = (3\hat{i} + 2\hat{j} + \hat{k})m$ . Work done by the force is

A. zero

B. 8 J

C. 4 J

D. 12 J

**Answer: A**



**Watch Video Solution**

9. A particle moves from point P(1,2,3) to (2,1,4) under the action of a constant force  $F = (2\hat{i} + \hat{j} + \hat{k})N$ . Work done by the force is

A. 2 J

B. 4 J

C. 16 J

D. 8 J

**Answer: A**



[Watch Video Solution](#)

10. Work done by a force  $F = (\hat{i} + 2\hat{j} + 3\hat{k})$  acting on a particle in displacing it from the point  $r_1 = \hat{i} + \hat{j} + \hat{k}$  to the point  $r_2 = \hat{i} - \hat{j} + 2\hat{k}$  is

A.  $-3J$

B.  $-1J$

C. zero

D.  $2J$

**Answer: B**



**Watch Video Solution**

**11.** A body constrained to move in the Y-direction, is subject to a force  $\vec{F} = (-2\hat{i} + 15\hat{j} + 6\hat{k})$  N. What is the work done by force in moving the body through a distance of 10 m along the Y-axis?

A. 20 J

B. 150 J

C. 160 J

D. 190 J

**Answer: B**



**Watch Video Solution**

12. Force acting on a particle is  $(2\hat{i} + 3\hat{j})N$ . Work done by this force is zero, when the particle is moved on the line  $3y + kx = 5$ . Here value of  $k$  is (Work done  $W = \vec{F} \cdot \vec{d}$ )

A. 2

B. 4

C. 6

D. 8

**Answer: A**



**Watch Video Solution**

**13.** A particale moves under the effect of a force  $F = Cx$  from  $x = 0$  to  $x = x_1$ . The work down in the process is

A.  $Cx_1^0$

B.  $Cx_1^2/2$

C. zero

D.  $Cx_1^3$

**Answer: B**



**Watch Video Solution**



14. A particle moves along the X-axis  $x=0$  to  $x=5$  m under the influence of a force given by  $F = 10 - 2x + 3x^2$ . Work done in the process is

- A. 70 units
- B. 270 units
- C. 35 units
- D. 150 units

**Answer: D**



[Watch Video Solution](#)

15. A position dependent force  $F = 8 - 4x + 3x^2$  N acts on a small body of mass 2 kg and displaces it from  $x=0$  to  $x=5$  m. The work done in joule is

A. 35

B. 70

C. 115

D. 270

**Answer: C**



**Watch Video Solution**

**16.** A force  $F = Ay^2 + By + C$  acts on a body at rest in the  $Y$ -direction. The kinetic energy of the body during a displacement  $y = -a$  to  $y = a$  is

A.  $\frac{2Aa^3}{3}$

B.  $\frac{2Aa^3}{3} + 2Ca$

C.  $\frac{2Aa^3}{3} + \frac{Ba^2}{2} + Ca$

D. None of these

**Answer: B**

 [Watch Video Solution](#)

17. The force  $F$  acting on a particle is moving in a straight line as shown in figure. What is the work done by the force on the particle in the 4 m of the trajectory?

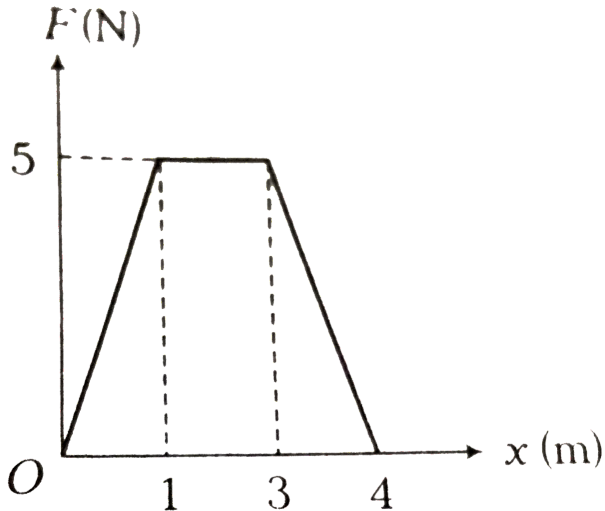

A. 5 J

B. 10 J

C. 15 J

D. 2.5 J

**Answer: C**

 [Watch Video Solution](#)

**18.** A position dependent force  $F$  is acting on a particle and its force-position curve is shown in the figure. Work done on the particle, when its displacement is from 0 to 5 m is

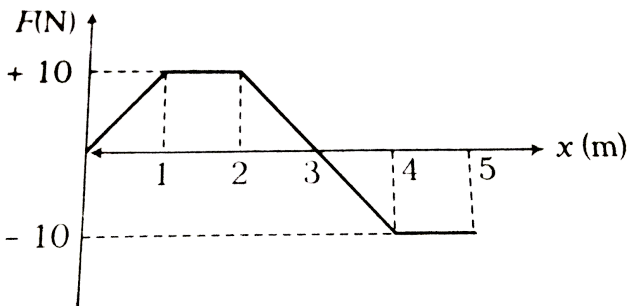

A. 35 J

B. 25 J

C. 15 J

D. 5 J

**Answer: D**



**Watch Video Solution**

**19.** A spring of force constant  $800\text{N}/\text{m}$  has an extension of 5cm.

The work done in extending it from 5cm to 15cm is

A. 16 J

B. 8 J

C. 32 J

D. 24 J

**Answer: B**



[Watch Video Solution](#)

20. A spring 40 mm long is stretched by the application of a force. If 10 N force required to stretch the spring through 1mm, then the work done in stretching the spring through 40 mm is

A. 84 J

B. 68 J

C. 23 J

D. 8 J

**Answer: D**



[Watch Video Solution](#)

## Check Point 6 2

1. If the force acting on a body is inversely proportional to its speed, the kinetic energy of the body is

- A. constant
- B. directly proportional to time
- C. inverserly proportional to time
- D. directly proportional to square of time

**Answer: B**

2. If the speed of a vehicle is increased by  $1\text{ms}^{-1}$ , its kinetic energy is doubled, then original speed of the vehicle is

A.  $(\sqrt{2} + 1)\text{ms}^{-1}$

B.  $2(\sqrt{2} - 1)\text{ms}^{-1}$

C.  $2(\sqrt{2} + 1)\text{ms}^{-1}$

D.  $\sqrt{2}(\sqrt{2} + 1)\text{ms}^{-1}$

**Answer: A**



[Watch Video Solution](#)

3. A running man has half the KE that a boy of half his mass has. The man speeds up by  $1.0\text{ms}^{-1}$  and then has the same energy as the boy. What were the original speeds of the man and the boy?



A.  $(\sqrt{2} + 1), (\sqrt{2} - 1)$

B.  $(\sqrt{2} + 1), 2(\sqrt{2} + 1)$

C.  $\sqrt{2}, \sqrt{2}$

D.  $(\sqrt{2} + 1), 2(\sqrt{2} - 1)$

**Answer: B**



**Watch Video Solution**

4. Two bodies of different masses  $m_1$  and  $m_2$  have equal momenta. Their kinetic energies  $E_1$  and  $E_2$  are in the ratio

A.  $\sqrt{\frac{m_2}{m_1}}$

B.  $\sqrt{\frac{m_1}{m_2}}$

C.  $\frac{m_1}{m_2}$

D.  $\frac{m_2}{m_1}$

**Answer: D**



**Watch Video Solution**

5. If the linear momentum is increased by 50%, then KE will be increased by :

A. 0.5

B. 1

C. 12.5

D. 0.25

**Answer: C**



**Watch Video Solution**

6. The graph between  $\sqrt{E}$  and  $\frac{1}{p}$  is (E=kinetic energy and p= momentum)

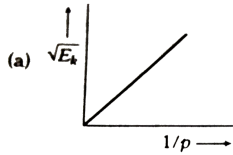

A.

B. 

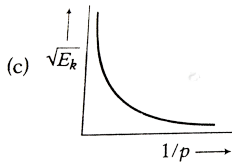

C.

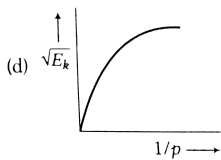

D.

**Answer: C**



**Watch Video Solution**

7. The KE acquired by a mass  $m$  in travelling a certain distance  $d$ , starting from rest, under the action of a constant force is directly proportional to

- A. directly proportional to  $m$
- B. directly proportional to  $\sqrt{m}$
- C. inversely proportional to  $\sqrt{m}$
- D. independent of  $m$

**Answer: D**



[Watch Video Solution](#)

8. Under the action of a force, a  $2kg$  body moves such that its position  $x$  as a function of time is given by  $x = \frac{t^3}{3}$  where  $x$  is in

metre and  $t$  in second. The work done by the force in the first two seconds is .

A. 1600 J

B. 160 J

C. 16 J

D. 1.6 J

**Answer: C**



**Watch Video Solution**

**9.** An object of mass 5 kg is acted upon by a force that varies with position of the object as shown. If the object starts out

from rest at a point  $x=0$ . What is its speed at  $x=50$  m.

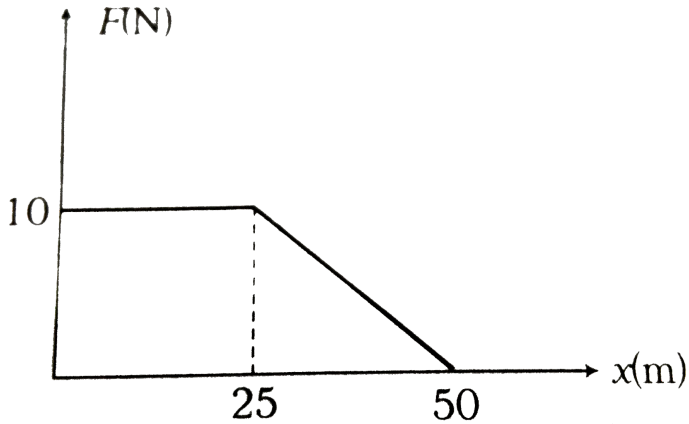

- A.  $12.2\text{ms}^{-1}$
- B.  $18.2\text{ms}^{-1}$
- C.  $16.4\text{ms}^{-1}$
- D.  $20.4\text{ms}^{-1}$

**Answer: A**



**Watch Video Solution**

10. A block of mass 20 kg is moving in x-direction with a constant speed of  $10 \text{ ms}^{-1}$ . It is subjected to a retarding force  $F = (-0.1x) \text{ N}$  during its travel from  $x=20 \text{ m}$  to  $x=30 \text{ m}$ . Its final kinetic energy will be

- A. 975 J
- B. 450 J
- C. 275 J
- D. 250 J

**Answer: A**



[Watch Video Solution](#)

11. Velocity-time graph of a particle of mass (2 kg) moving in a straight line is as shown in Fig. 9.20. Find the work done by all

the forces acting on the particle.

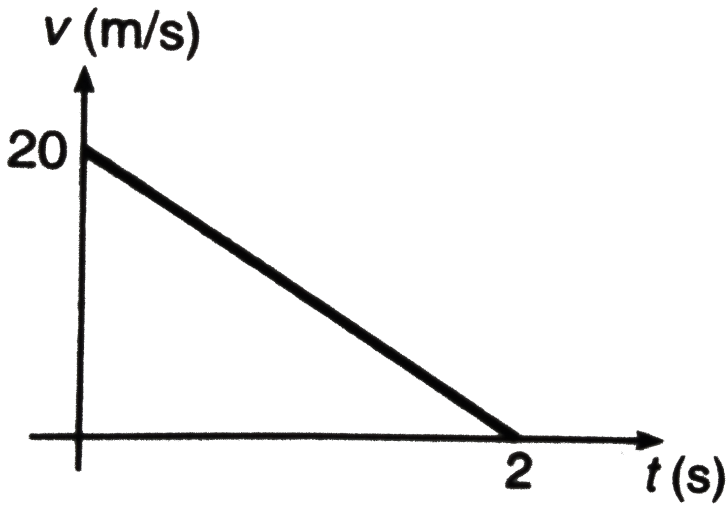

- A.  $400J$
- B.  $-400J$
- C.  $-200J$
- D.  $200J$

**Answer: B**

 [Watch Video Solution](#)



12. A particle of mass 0.01 kg travels along a space curve with velocity given by  $4\hat{i} + 16\hat{k}m/s$ . After some time its velocity becomes  $8\hat{i} + 20\hat{j}m/s$  due to the action of a conservative force. The work done on the particle during this interval of time is:

- A. 0.32 J
- B. 6.9 J
- C. 9.6 J
- D. 0.96 J

**Answer: D**



[Watch Video Solution](#)

13. A mass of 1 kg is acted upon by a single force  $F = (4\hat{i} + 4\hat{j})N$ . Under this force it is displaced from (0,0) to

(1m,1m). If initially the speed of the particle was  $2 \text{ m s}^{-1}$ , its final speed should be

A.  $6 \text{ m s}^{-1}$

B.  $4.5 \text{ m s}^{-1}$

C.  $8 \text{ m s}^{-1}$

D.  $4 \text{ m s}^{-1}$

**Answer: B**



**Watch Video Solution**

**14.** A body of mass 5 kg is raised vertically to a height of 10 m by a force 170 N. The velocity of the body at this height will be

A.  $9.8 \text{ m s}^{-1}$

B.  $15 \text{ m s}^{-1}$

C.  $22 \text{ m s}^{-1}$

D.  $37 \text{ m s}^{-1}$

**Answer: C**



**Watch Video Solution**

**15.** A body of mass  $0.1 \text{ g}$  moving with a velocity of  $10 \text{ m/s}$  hits a spring (fixed at the other end) of force constant  $1000 \text{ N/m}$  and comes to rest after compressing the spring. The compression of the spring is

A.  $0.01 \text{ m}$

B.  $0.1 \text{ m}$

C.  $0.2 \text{ m}$

D.  $0.5 \text{ m}$

**Answer: B**



[Watch Video Solution](#)

**16.** A block of mass 2 kg is dropped from a height of 40 cm on a spring whose force-constant  $1960Nm^{-1}$ . The maximum distance through which the spring is compressed by

A. 10 cm

B. 1 cm

C. 20 cm

D. 5 cm

**Answer: A**



[Watch Video Solution](#)

17. In which of the following cases the, potential energy is defined?

- A. both conservative and non-conservative forces
- B. conservative force only
- C. non-conservative force only
- D. Neither conservative nor-conservative forces

**Answer: B**



[Watch Video Solution](#)

18. The potential energy of a system increased if work is done

- A. by the system against a conservative force
- B. by the system against a non-conservative force

C. upon the system by a conservative force

D. upon the system by a non-conservative force

**Answer: A**

 [Watch Video Solution](#)

19. A pendulum of length 2 m lift at P . When it reaches Q , it losses 10% of its total energy due to air resistance. The velocity at Q is

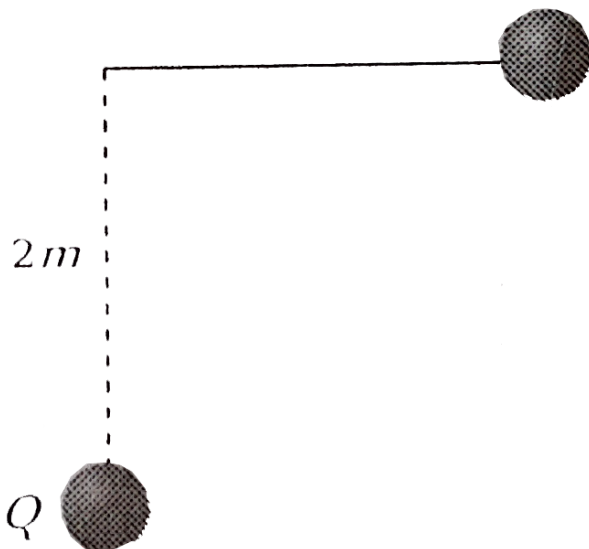

A.  $6ms^{-1}$

B.  $1ms^{-1}$

C.  $2ms^{-1}$

D.  $8ms^{-1}$

**Answer: C**



**Watch Video Solution**

**20.** A body of mass  $m$  thrown vertically upwards attains a maximum height  $h$ . At height will its kinetic energy be 75% of its initial value?

A.  $\frac{h}{6}$

B.  $\frac{h}{5}$

C.  $\frac{h}{4}$

D.  $\frac{h}{3}$

**Answer: C**



**Watch Video Solution**

### Check Point 6 3

1. A body of mass  $m$  is accelerated uniformly from rest to a speed  $v$  in a time  $T$ . The instantaneous power delivered to the body as a function of time is given by

A.  $\frac{Mv^2}{T}$

B.  $\frac{1}{2} \frac{Mv^2}{T^2}$

C.  $\frac{Mv^2}{T^2}$

D.  $\frac{1}{2} \frac{Mv^2}{T}$



**Answer: D**



**Watch Video Solution**

2. An engine develops 10 kW of power. How much time will it take to lift a mass of 200 kg to a height of 40 m ( $g = 10 \frac{m}{sec^2}$ )?

A. 4 s

B. 5 s

C. 8 s

D. 10 s

**Answer: C**



**Watch Video Solution**

3. An engineer claims to have made an engine delivering 10 kW power with fuel consumption of  $1\text{g s}^{-1}$ . The calorific value of fuel is 2 kcal / g . His claim

- A. valid
- B. invalid
- C. dependent on engine design
- D. dependent on load

**Answer: B**



[Watch Video Solution](#)

4. Water falls from a height of 60m at the rate  $15\text{kg/s}$  to operate a turbine. The losses due to frictional forces are 10%

of energy . How much power is generated to by the turbine?

( $g=10 \text{ m//s}^{\wedge}(2)$ )`.

A. 12.3 kW

B. 7 kW

C. 8.1 kW

D. 10.2 kW

**Answer: C**



**Watch Video Solution**

5. A 60 kg man runs up a staircase in 12 seconds while 50 kg man runs up the same staircase in 11, seconds, the ratio of the rate of doing their work is

A. 6 : 5

B. 12: 11

C. 11: 10

D. 10:11`

**Answer: C**



**Watch Video Solution**

**6.** If the heart pushes 1 cc of blood in one second under pressure 20000 N/m<sup>2</sup> the power of heart is

A. 0.02 W

B. 400 W

C.  $5 \times 10^{-10}$ W

D. 0.2 W

**Answer: A**



**Watch Video Solution**

7. A body of mass 10 kg moves with a constant speed  $v$  of  $2 \text{ ms}^{-1}$  along a circular path of radius 8 m. The power produced by the body will be

A.  $10 \text{ Js}^{-1}$

B.  $98 \text{ Js}^{-1}$

C.  $49 \text{ Js}^{-1}$

D. zero

**Answer: D**



**Watch Video Solution**

8. A force  $2\hat{i} + 3\hat{j} + 4\hat{k}$  N acts on a body for 4 sec, produces a displacement of  $(3\hat{i} + 4\hat{j} + 5\hat{k})$  m. the power used is

A. 9.5 W

B. 7.5 W

C. 6.5 W

D. 4.5 W

**Answer: A**



[Watch Video Solution](#)

9. A particle moves with a velocity  $v = (5\hat{i} - 3\hat{j} + 6\hat{k}) \text{ms}^{-1}$

under the influence of a constant force

$F = (10\hat{i} + 10\hat{j} + 20\hat{h}) \text{N}$ , the instantaneous power applied to the particle is.

A.  $200 \text{ J s}^{-1}$

B.  $40 \text{ J s}^{-1}$

C.  $140 \text{ J s}^{-1}$

D.  $170 \text{ J s}^{-1}$

**Answer: C**



**Watch Video Solution**

**10.** A body of mass  $2 \text{ kg}$  is projected at  $20 \text{ m s}^{-1}$  at an angle  $60^\circ$  above the horizontal. Power due to the gravitational force at its highest point is

A.  $200 \text{ W}$

B.  $100\sqrt{3} \text{ W}$

C.  $50 \text{ W}$

D. zero

**Answer: D**



**Watch Video Solution**

## Exercises Taking It Together

1. An electron and a proton are moving under the influence of mutual forces. In calculating the change in the kinetic energy of the system during motion, one ignores the magnetic force of one on another. This is because,

- A. the two magnetic forces are equal and opposite, so they produce no net effect
- B. the magnetic forces do not work on each particle



- C. the magnetic forces do equal and opposite (but non-zero) work on each particle
- D. the magnetic forces are necessarily negligible

**Answer: B**



[Watch Video Solution](#)

2. A man squatting on the ground gets straight up and stand. The force of reaction of ground on the man during the process is.

- A. constant and equal to  $mg$  in magnitude
- B. constant and greater than  $mg$  in magnitude
- C. variable but always greater than  $mg$
- D. at first greater than  $mg$  and later becomes equal to  $mg$

**Answer: D**



**Watch Video Solution**

3. A body is falling freely under the action of gravity alone in vacuum. Which of the following quantities remain constant during the fall ?

- A. Kinetic energy
- B. Potential energy
- C. Total mechanical energy
- D. Total linear momentum

**Answer: C**



**Watch Video Solution**

4. A particle is moved from  $(0, 0) \rightarrow (a, a)$  under a force  $F = (x^2\hat{i} + y^3\hat{j})$  from two paths. Path 1 is  $OP$  and Path 2 is  $OQP$ . Let  $W_1$  and  $W_2$  be the work done by this force in these two paths. Then

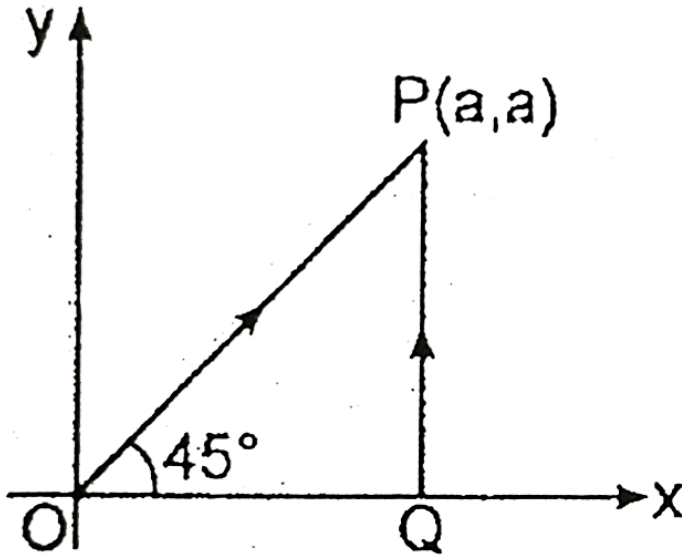

- A.  $W_1 = W_2$
- B.  $W_1 = 2W_2$
- C.  $W_2 = 2W_1$
- D.  $W_2 = 4W_1$

Answer: A

 Watch Video Solution

5. A body of mass  $m$  was slowly pulled up the hill by a force  $F$  which at each point was directed along the tangent of the trajectory. All surfaces are smooth. Find the work performed by this force.

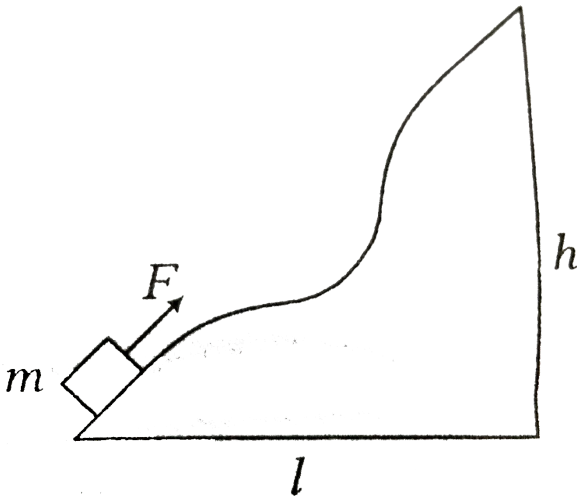

A.  $mg l$

B.  $-mgl$

C.  $mgh$

D. zero

**Answer: C**



**Watch Video Solution**

6. A rod of mass  $m$  and length  $l$  is lying on a horizontal table.

Work done in making it stand on one end will be

A.  $mgl$

B.  $\frac{mgl}{2}$

C.  $\frac{mgl}{4}$

D.  $2mgl$

Answer: B

 Watch Video Solution

7. The pointer reading versus load graph for a spring balance is as shown in the figure.

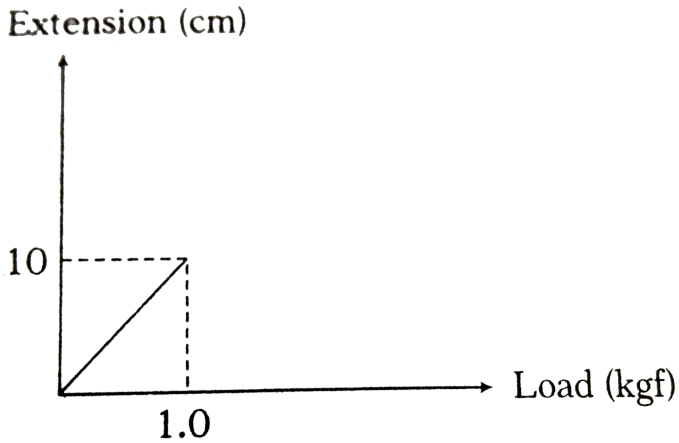

The spring constant is

A.  $15\text{kgf}/\text{cm}$

B.  $5\text{kg}/\text{cm}$

C.  $0.1\text{kgf}/\text{cm}$

D.  $10\text{kgf}/\text{cm}$

**Answer: C**



**Watch Video Solution**

8. The momentum of a body is  $p$  and its kinetic energy is  $E$ . Its momentum becomes  $2p$ . Its kinetic energy will be

A.  $\frac{E}{2}$

B.  $3E$

C.  $2E$

D.  $4E$

**Answer: D**



**Watch Video Solution**

9. If  $v$ ,  $p$  and  $E$  denote velocity, linear momentum and KE of the particle respectively, then

A.  $p = \frac{dE}{dv}$

B.  $p = \frac{dE}{dt}$

C.  $p = \frac{dv}{dt}$

D.  $p = \frac{dE}{dv} \times \frac{dE}{dt}$

**Answer: A**



**Watch Video Solution**

10. Two masses of 1 gm and 4 gm are moving with equal kinetic energies. The ratio of the magnitudes of their linear momenta is



A. 4: 1

B.  $\sqrt{2}$ : 1

C. 1: 2

D. 1: 16

**Answer: C**



**Watch Video Solution**

**11.** When work done by force of gravity is negative, then

A. PE increases

B. KE increases

C. PE remains constant

D. PE decrease

**Answer: A**



**Watch Video Solution**

**12.** A bicyclist comes to a skidding stop in 10m. During this process, the force on the bicycle due to the road is 200N and is directly opposed to the motion. The work done by the cycle on the road is

A.  $+2000J$

B.  $-200J$

C. zero

D.  $-20000J$

**Answer: C**



**Watch Video Solution**

13. A body is moving unidirectionally under the influence of a source of constant power supplying energy. Which of the diagrams shown in figure correctly shows the displacement-time curve for its motion?

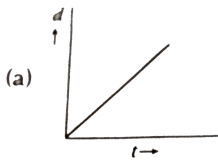

A.

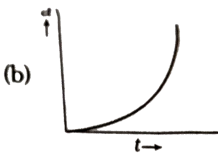

B.

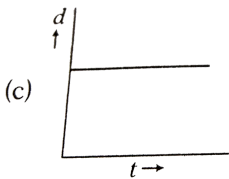

C.

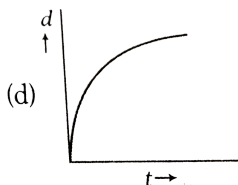

D.

Answer: B

 Watch Video Solution

14. Which of the diagrams shown in figure most closely shows the variation in Kinetic energy of the earth as it moves once around the sun in its elliptical orbit?

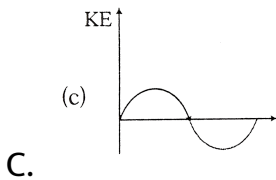
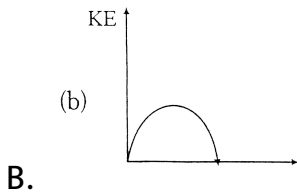
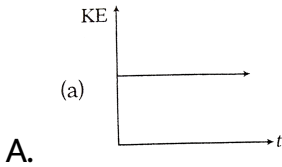

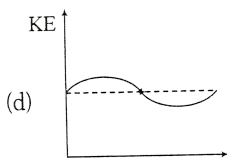

D.

**Answer: D**

 **Watch Video Solution**

**15.** Which of the diagrams shown in figure represents variation of total mechanical energy of a pendulum oscillating in air as function of time?

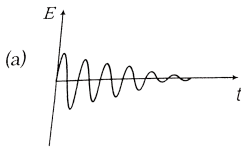

A.

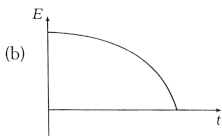

B.

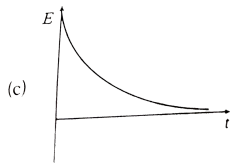

C.

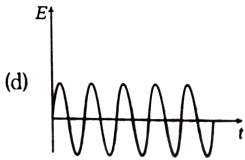

D.

**Answer: C**



**Watch Video Solution**

**16.** A mass of  $5\text{kg}$  is moving along a circular path of radius  $1\text{m}$ . If the mass moves with 300 revolutions per minute, its kinetic energy would be

A.  $250\pi^2$

B.  $100\pi^2$

C.  $5\pi^2$

D. 0

**Answer: A**



**Watch Video Solution**

17. A particle moves from position  $3\hat{i} + 2\hat{j} - 6\hat{k}$  to  $14\hat{i} + 13\hat{j} + 9\hat{k}$  due to a force  $\vec{F} = (4\hat{i} + \hat{j} + 3\hat{k})\text{N}$ . If the displacement is in centimeter then work done will be

A. 1 J

B. 2 J

C. 3 J

D. 2.5 J

**Answer: A**



**Watch Video Solution**

18. A body moves from rest with a constant acceleration. Which one of the following graphs represents the variation of its kinetic energy  $K$  with the distance travelled  $x$ ?

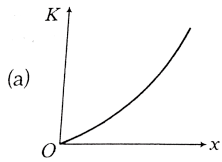

A.

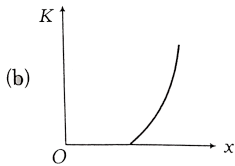

B.

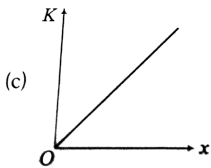

C.

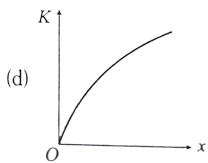

D.



Answer: C

 Watch Video Solution

19.  $v - t$  graph of an object of mass 1 kg is shown. Select the wrong statement.

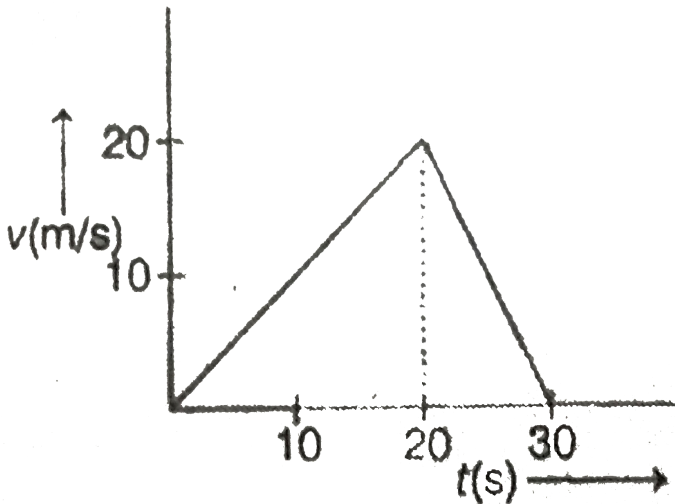

- A. Work done on the object in 30 s is zero
- B. The average acceleration of the object is zero
- C. The average velocity of the object is zero

D. The average force on the object is zero

**Answer: C**



**Watch Video Solution**

**20.** A toy gun a spring of force constant  $k$ . When changed before being triggered in the upward direction, the spring is compressed by a distance  $x$ . If the mass of the shot is  $m$ , on the being triggered it will go up to a height of

A.  $\frac{kx^2}{mg}$

B.  $\frac{x^2}{kmg}$

C.  $\frac{kx^2}{2mg}$

D.  $\frac{(kx)^2}{mg}$

**Answer: C**



**Watch Video Solution**

21. A car moving with a speed of  $40\text{km/h}$  can be stopped by applying the brakes after at least 2 m. If the same car is moving with a speed of  $80\text{km/h}$ , what is the minimum stopping distance?

A. 8 m

B. 2 m

C. 4 m

D. 6 m

**Answer: A**



**Watch Video Solution**

22. A long elastic spring is stretched by  $2\text{cm}$  and its potential energy is  $U$ . If the spring is stretched by  $10\text{cm}$ , the  $PE$  will be

A.  $\frac{U}{25}$

B.  $\frac{U}{5}$

C.  $5U$

D.  $25U$

**Answer: D**



**Watch Video Solution**

23. A body (initially at rest) is falling under gravity. When it loses a gravitational potential energy by  $U$ , its speed is  $v$ . The mass of the body shall be :

A.  $\frac{2U}{v}$

B.  $\frac{U}{2v}$

C.  $\frac{2U}{v^2}$

D.  $\frac{U}{2v^2}$

**Answer: C**



**Watch Video Solution**

**24.** If a body of mass 200 g falls a height 200 m and its total P.E. is converted into K.E. at the point of contact of the body with earth surface. Then what is the decrease in P.E. of the body at the contact.

$$(g = 10m / s^2)$$

A. 900 J

B. 600 J

C. 400 J

D. 200 J

**Answer: C**



**Watch Video Solution**

**25.** A stone of mass 2 kg is projected upwards with KE of 98 J.

The height at which the KE of the body becomes half its original

value, is given by (take,  $g = 9.8ms^{-2}$ )

A. 5 m

B. 2.5 m

C. 1.5 m

D. 0.5 m

**Answer: B**



**Watch Video Solution**

**26.** Mark out the correct statement(s).

- A. Total work done by internal forces on a system is always zero
- B. Total work done by internal forces on a system may sometimes be zero
- C. Total work done by friction can never be zero
- D. Total work done by friction is always zero

**Answer: B**



**Watch Video Solution**

27. A vehicle needs an engine of 7500 W to keep it moving with a constant velocity of  $20 \text{ ms}^{-1}$  on a horizontal surface. The force resisting the motion is

- A. 375 dyne
- B. 375 N
- C. 150000 dyne
- D. 150000 N

**Answer: B**



[Watch Video Solution](#)

28. An engine exerts a force  $F = (20\hat{i} - 3\hat{j} + 5\hat{k})$  N and moves with velocity  $v = (6\hat{i} + 20\hat{j} - 3\hat{k}) \text{ ms}^{-1}$ . The power of the engine (in watt) is



A. 45

B. 75

C. 20

D. 10

**Answer: A**



**Watch Video Solution**

**29.** An object of mass  $m$ , initially at rest under the action of a constant force  $F$  attains a velocity  $v$  in time  $t$ . Then, the average power supplied to mass is

A.  $\frac{mv^2}{2t}$

B.  $\frac{Fv}{2}$

C. Both are correct

D. Both are wrong

**Answer: C**

 [Watch Video Solution](#)

**30.** A particle at rest on a frictionless table is acted upon by a horizontal force which is constant in magnitude and direction. A graph is plotted of the work done on the particle  $W$ , against the speed of the particle  $v$ . If there are no frictional forces acting on the particle, the graph will look like

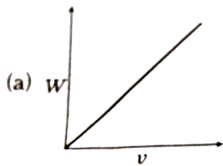

A.

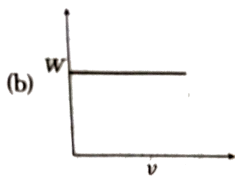

B.

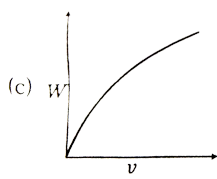

C.

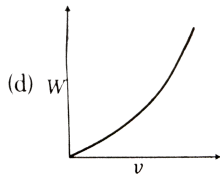

D.

**Answer: D**



**Watch Video Solution**

**31.** The energy required to accelerate a car from 10 m/s to 20 m / s is how many times the energy required to accelerate the car from rest to 10 m /s

A. Work done on the object in 30 s is zero

B. 2 W

C. 3 W

D. 4 W

**Answer: C**



**Watch Video Solution**

**32.** A force  $F = -k\hat{i} + x\hat{j}$  where  $k$  is a positive constant, acts on a particle moving in the  $xy$  plane. Starting from the origin, the particle is taken along the positive  $x$  - axis to the point  $(a,0)$  and then parallel to the  $y$ -axis to the point  $(a,a)$  the total work done by the force on the particle is

A.  $-2ka^2$

B.  $2ka^2$

C.  $-ka^2$

D.  $ka^2$

**Answer: C**



**Watch Video Solution**

**33.** Given that the displacement of the body in meter is a function of time as follows

$$x = 2t^4 + 5$$

The mass of the body is 2 kg. What is the increase in its kinetic energy one second after the start of motion?

A. 8 J

B. 16 J

C. 32 J

D. 64 J

**Answer: D**



**Watch Video Solution**

**34.** A block is attached to a spring as shown and very-very gradually lowered so that finally spring expands by 'd'. If same block is attached to spring and released suddenly then

maximum expansion in spring will be

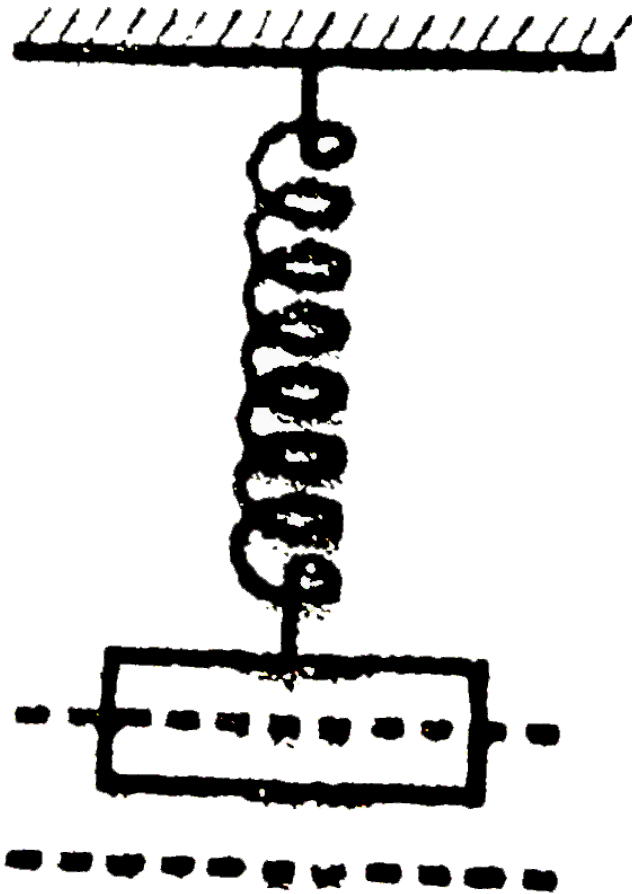

A.  $d$

B.  $2d$

C.  $3d$

D.  $(1/2)d$

**Answer: B**



**Watch Video Solution**

**35.** A uniform chain of length  $L$  and mass  $M$  is lying on a smooth table and one third of its length is hanging vertically down over the edge of the table. If  $g$  is acceleration due to gravity, work required to pull the hanging part on to the table is

A.  $MgL$

B.  $\frac{MgL}{3}$

C.  $\frac{MgL}{9}$

D.  $\frac{MgL}{18}$



Answer: D

 Watch Video Solution

36. An object of mass  $m$  is tied to a string of length  $L$  and a variable force  $F$  is applied on it which brings the string gradually at angle  $\theta$  with the vertical. Find the work done by the force  $F$ .

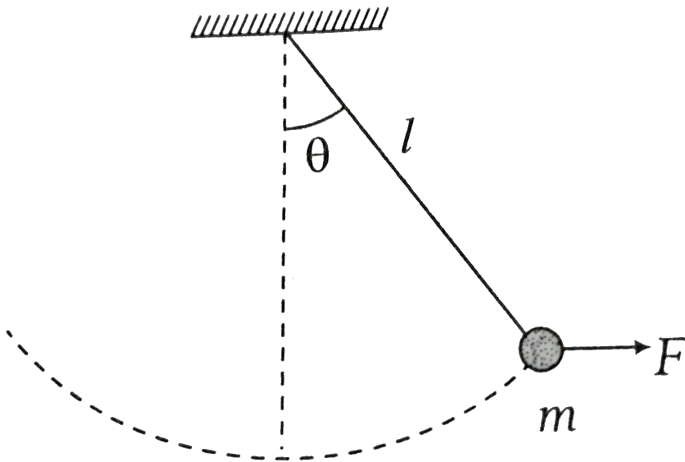

A.  $mgL(1 - \sin \theta)$

B.  $mgL$

C.  $mgL(1 - \cos \theta)$

D.  $mgL(1 + \cos \theta)$

**Answer: C**



**Watch Video Solution**

**37.** A particle is moving in a conservative force field from point A to point B.  $U_A$  and  $U_B$  are the potential energies of the particle at point A and B and  $W_C$  is the work done by conservative forces in the process of taking the particle from A and B, which of the following is true?

A.  $W_c = U_B - U_A$

B.  $W_C = U_A - U_B$

C.  $U_A > U_B$

$$D. U_B > U_A$$

**Answer: B**



**Watch Video Solution**

**38.** Three particles A, B and C are thrown from the top of a tower with the same speed. A is thrown straight up, B is thrown straight down and C is thrown horizontally. They hit the ground with speeds  $v_A$ ,  $v_B$  and  $v_C$  respectively:

A.  $v_A = v_B > v_C$

B.  $v_A = v_B = v_C$

C.  $v_A > v_B = v_C$

D.  $v_B > v_C > v_A$

Answer: B

 Watch Video Solution

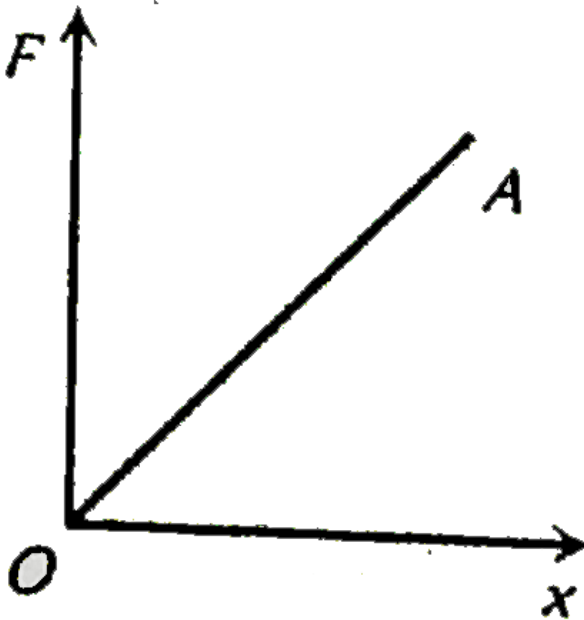

39.

The force required to stretch a spring varies with the distance as shown in the figure. If the experiment is performed with the above spring of half length, the line OA will

- A. shift towards F-axis
- B. shift towards X-axis
- C. remain as it is
- D. become double in length

**Answer: A**



**Watch Video Solution**

**40.** Kinetic energy of a particle moving in a straight line varies with time  $t$  as  $K = 4t^2$ . The force acting on the particle

- A. is constant
- B. is increasing
- C. is decreasing

D. first increases and then decreases

**Answer: A**



**Watch Video Solution**

41. A particle is released from height  $H$ . At certain height from the ground its kinetic energy is twice its gravitational potential energy. Find the height and speed of particle at that height.

A.  $\frac{H}{3}, \sqrt{\frac{2gH}{3}}$

B.  $\frac{H}{3}, 2\sqrt{\frac{gH}{3}}$

C.  $\frac{2H}{3}, \sqrt{\frac{2gH}{3}}$

D.  $\frac{H}{3}, \sqrt{2gH}$

**Answer: B**



**Watch Video Solution**

42. Power applied to a particle varies with time as  $P = (3t^2 - 2t + 1)$  watt, where  $t$  is in second. Find the change in its kinetic energy between time  $t = 2s$  and  $t = 4s$ .

A. 32 J

B. 46 J

C. 61 J

D. 102 J

**Answer: B**

43. A motor drives a body along a straight line with a constant force. The power  $P$  developed by the motor must vary with time  $t$  as

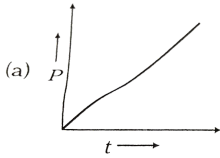

A.

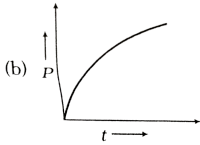

B.

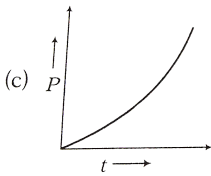

C.

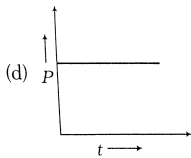

D.

**Answer: A**



**Watch Video Solution**



44. Power supplied to a mass  $2\text{kg}$  varies with time as  $P = \frac{3t^2}{2}$  watt. Here  $t$  is in second . If velocity of particle at  $t = 0$  is  $v = 0$ , the velocity of particle at time  $t = 2\text{s}$  will be:

A.  $1\text{ms}^{-1}$

B.  $4\text{ms}^{-1}$

C.  $2\text{ms}^{-1}$

D.  $2\sqrt{2}\text{ms}^{-1}$

**Answer: C**



**Watch Video Solution**

45. A force  $F$  acting on a body depends on its displacement  $S$  as  $F \propto S^{-1/3}$  . The power delivered by  $F$  will depend on

displacement as

A.  $S^{2/3}$

B.  $S^{-5/3}$

C.  $S^{1/2}$

D.  $S^0$

**Answer: D**



**Watch Video Solution**

**46.** A ball is thrown vertically upwards with a velocity of  $10 \text{ ms}^{-1}$ . It returns to the ground with a velocity of  $9 \text{ ms}^{-1}$ . If  $g=9.8 \text{ ms}^{-2}$ , then the maximum height attained by the ball is nearly (assume air resistance to be uniform)

A. 5.1 m

B. 4.1 m

C. 4.61 m

D. 5 m

**Answer: C**



**Watch Video Solution**

**47.** An open knife of mass  $m$  is dropped from a height  $h$  on a wooden floor. If the blade penetrates up to the depth  $d$  into the wood. The average resistance offered by the wood to the knife edge is .

A.  $mg\left(1 + \frac{h}{d}\right)$

B.  $mg\left(1 + \frac{h}{d}\right)^2$

C.  $mg\left(1 - \frac{h}{d}\right)$

$$D. mg\left(1 + \frac{d}{h}\right)$$

Answer: A

 Watch Video Solution

48. The force acting on a body moving along x-axis variation of the particle shown in the figure. The body is in stable equilibrium at

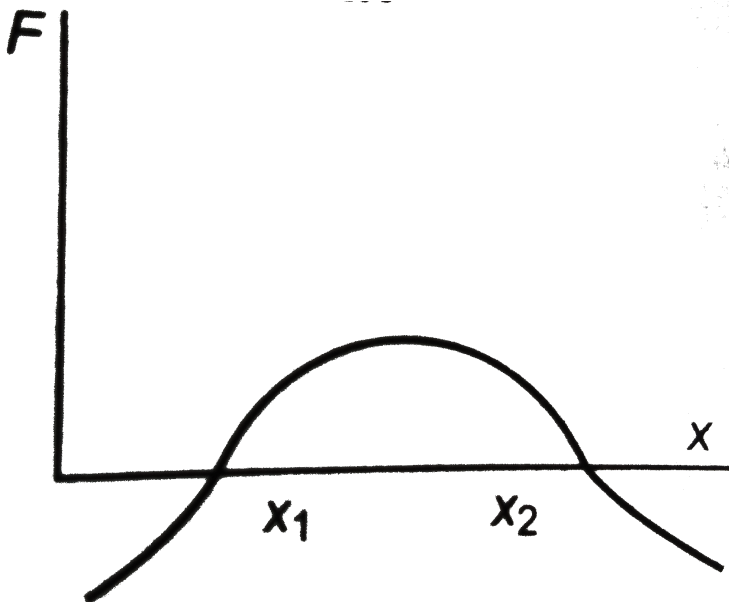

A.  $x = x_1$

B.  $x = x_2$

C. Both  $x_1$  and  $x_2$

D. Neither  $x_1$  nor  $x_2$

**Answer: B**



**Watch Video Solution**

**49.** How much mass is converted into energy per day in a nuclear power plant operated at  $10^7$  kW?

A. 9.6 g

B. 9.63 kg

C. 8.6 g

D. 7 g

**Answer: A**



**Watch Video Solution**

**50.** A block of mass  $M$  is pulled along a horizontal surface by applying a force at angle  $\theta$  with the horizontal. The friction coefficient between the block and the surface is  $\mu$ . If the block travels at a uniform velocity, find the work done by this applied force during a displacement  $d$  of the block.

A.  $\frac{\mu mgd}{\cos \theta + \mu \sin \theta}$

B.  $\frac{\mu mgd \cos \theta}{\cos \theta + \mu \sin \theta}$

C.  $\frac{\mu mgd \sin \theta}{\cos \theta + \mu \sin \theta}$

D.  $\frac{\mu mgd \cos \theta}{\cos \theta - \mu \sin \theta}$

**Answer: B**



**Watch Video Solution**

51. If  $v$  be the instantaneous velocity of the body dropped from the top of a tower, when it is located at height  $h$ , then which of the following remains constant?

A.  $gh + v^2$

B.  $gh + \frac{v^2}{2}$

C.  $gh - \frac{v^2}{2}$

D.  $gh - v^2$

**Answer: B**



**Watch Video Solution**

52. A block of mass 1 kg slides down a rough inclined plane of inclination  $60^\circ$  starting from its top. If coefficient of kinetic is 0.5 and length of the plane  $d=2$  m, then work done against friction is

A. 2.45 J

B. 4.9 J

C. 9.8 J

D. 19.6 J

**Answer: B**



[Watch Video Solution](#)

53. A proton is kept at rest. A positively charged particle is released from rest at a distance  $d$  in its field. Consider two



experiments, one in which the charged particle is also a proton and in another, a positron. In the same time  $t$ , the work done on the two moving charged particles is

- A. same as the same force law is involved in the two experiments
- B. less for the case of a positron, as the positron moves away more rapidly and the force on it weakens
- C. more for the case of a positron, as the positron moves away a larger distance
- D. same as the work done by charged particle on the stationary proton

**Answer: C**



**Watch Video Solution**

54. Two inclined frictionless tracks, one gradual and the other steep meet at A from where two stones are allowed to slide down from rest, one on each track as shown in figure. Which of the following statements is correct?

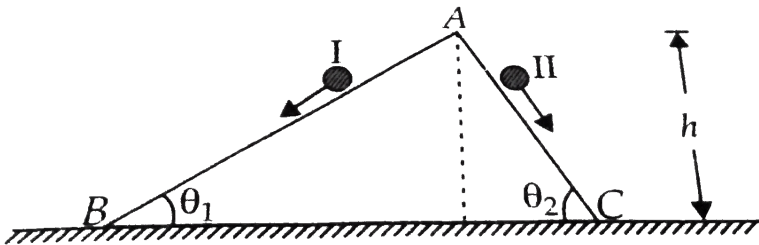

- A. Both the stones reach the bottom at the same time but not with the same speed
- B. Both the stones reach the bottom with the same speed and stone I reaches the bottom earlier than stone II
- C. Both the stones reach the bottom with the same speed and stone II reaches the bottom earlier than stone I

D. Both the stones reach the bottom at different times and with different speeds

**Answer: C**



**Watch Video Solution**

55. The potential energy function for a particle executing linear SHM is given by  $V(x) = \frac{1}{2}kx^2$  where  $k$  is the force constant of the oscillator. For  $k = 0.5Nm^{-1}$ , the graph of  $V(x)$  versus  $x$  is shown in the figure A particle of total energy  $E$  turns back when it reaches  $x = \pm x_m$ .if  $V$  and  $K$  indicate the potential energy and kinetic energy respectively of the particle at  $x = +x_m$

,then which of the following is correct?

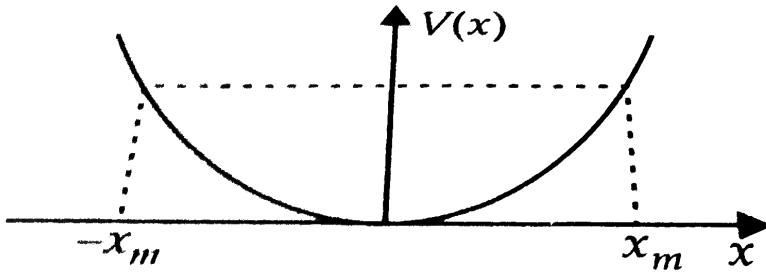

- A.  $V=0, K=E$
- B.  $V=E, K=0$
- C.  $V \text{ lt } E, K=0$
- D.  $V=0, K \text{ lt } E$

**Answer: B**



**Watch Video Solution**

**56.** A body of mass  $0.5\text{kg}$  travels in a straight line with velocity  $v = ax^{3/2}$  where  $a = 5\text{m/s}^2$ . The work done by the net force

during its displacement from  $x = 0$  to  $x = 2m$  is

A. 1.5 J

B. 50 J

C. 10 J

D. 100 J

**Answer: B**



[Watch Video Solution](#)

57. A raindrop falling from a height  $h$  above ground, pure ring attains a near terminal velocity when it has fallen through a height  $\left(\frac{3}{4}\right)h$ . Which of the diagrams shown in figure correctly shows the change in kinetic and potential energy of the drop during its fall up to the ground ?

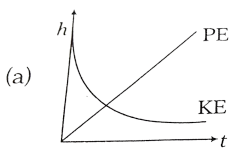

A.

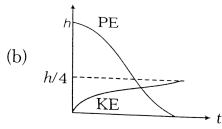

B.

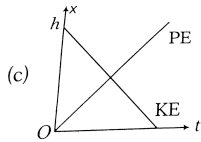

C.

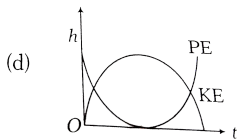

D.

**Answer: B**



**Watch Video Solution**

**58.** In a shotput event an athlete throws the shotput of mass  $10\text{kg}$  with an initial speed of  $1\text{ms}^{-1}$  at  $45^\circ$  from a height  $1.5\text{m}$  above ground. Assuming air resistance to be negligible and

acceleration due to gravity to be  $10ms^{-2}$ , the kinetic energy of the shotput when it just reaches the ground will be

- A. 2.5 J
- B. 5 J
- C. 52.5 J
- D. 155 J

**Answer: D**



[Watch Video Solution](#)

**59.** The potential energy between two atoms in a molecule is given by  $U(x) = \frac{a}{x^{12}} - \frac{b}{x^6}$ , where  $a$  and  $b$  are positive constants and  $x$  is the distance between the atoms. The atom is in stable equilibrium when

A.  $x=0$

B.  $x = \left(\frac{a}{2b}\right)^{1/6}$

C.  $x = \left(\frac{2a}{b}\right)^{1/6}$

D.  $x = \left(\frac{11a}{5b}\right)^{1/6}$

**Answer: C**



**Watch Video Solution**

**60.** In position A kinetic energy of a particle is 60 J and potential energy is -20 J. In position B, kinetic energy is 100 J and potential energy is 40 J. Then, in moving the particle from A to B

A. work done by conservative forces is 50 J

B. work done by external forces is 40 J

C. net work done by all the forces 40 J



D. net work done by all the forces 100 J

Answer: C

 Watch Video Solution

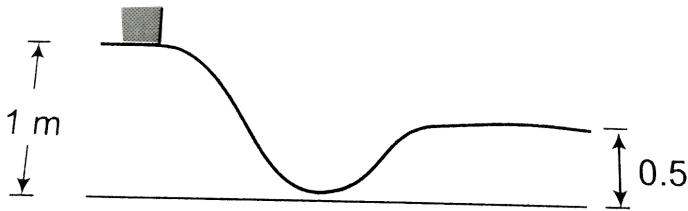

61.

The figure shown a particle sliding on a frictionless track, which terminates in a straight horizontal section. If the particle starts slipping from the point  $A$ , how far away from the track will the particle hit the ground?

A. 1 m

B. 2 m

C. 3 m

D. 4 m

**Answer: A**

 [Watch Video Solution](#)

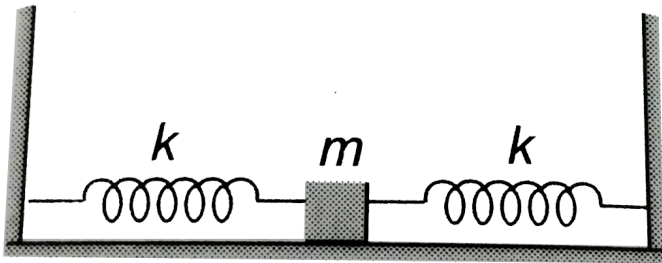

62.

A block of mass  $m$  is attached to two unstretched springs of spring constant  $k$ , each as shown. The block is displaced towards right through a distance  $x$  and is released. The speed of the block as it passes through the mean position will be

A.  $x \sqrt{\frac{m}{2k}}$

B.  $x \sqrt{\frac{2k}{m}}$

C.  $x \sqrt{\frac{m}{k}}$

D.  $x \frac{2k}{m}$

**Answer: B**

 **Watch Video Solution**

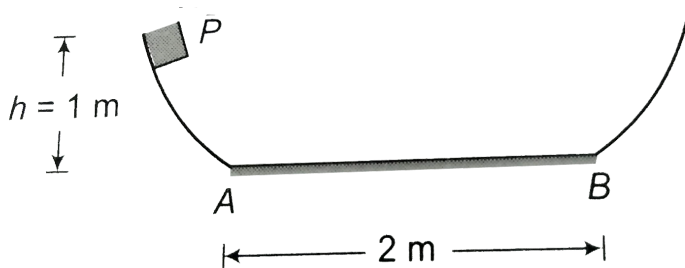

**63.**

The curved portions are smooth and horizontal surface is rough.

The block is released from  $P$ . At what distance from  $A$  it will stop? the friction coefficient for rough flat surface is  $0.2$ .

A. 1 m

B. 2 m

C. 3 m

D. 4 m

**Answer: A**



**Watch Video Solution**

**64.** The system shown in the figure is released from rest. At the instant when mass  $M$  has fallen through a distance  $h$ , the

velocity

of

m

will

be

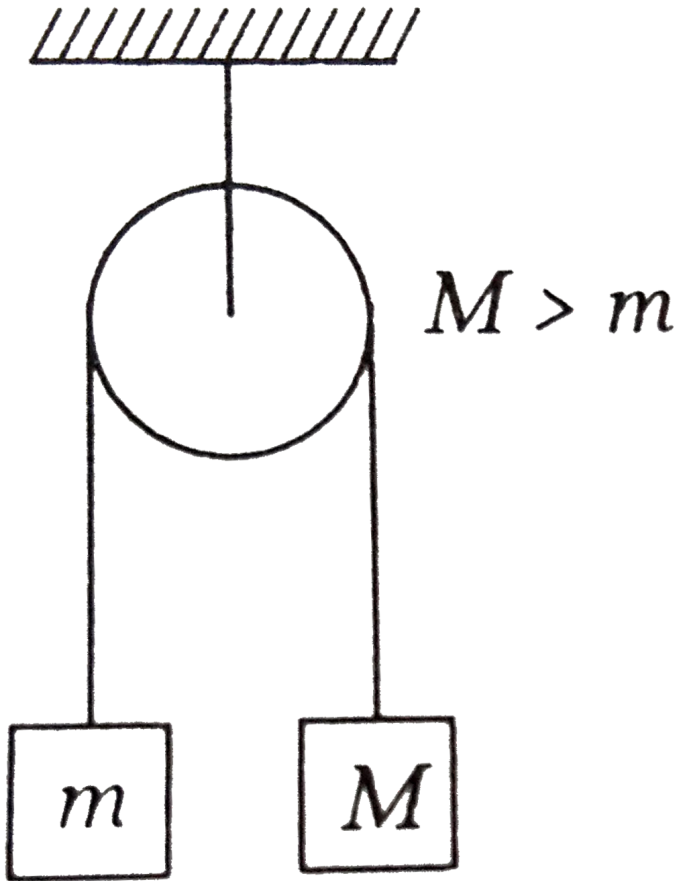

A.  $\sqrt{2gh}$

B.  $\frac{\sqrt{2ghM}}{m}$

C.  $\sqrt{\frac{2gh(M - m)}{m + M}}$

D.  $\sqrt{\frac{2gh(M + m)}{m - M}}$

Answer: C

 [Watch Video Solution](#)

65. A plank of mass 10 kg and a block of mass 2 kg are placed on a horizontal plane as shown in the figure. There is no friction between plane and plank. The coefficient of friction between block and plank is 0.5 .A force of 60 N is applied on plank horizontally. In first 2 s the work done by friction on the block is

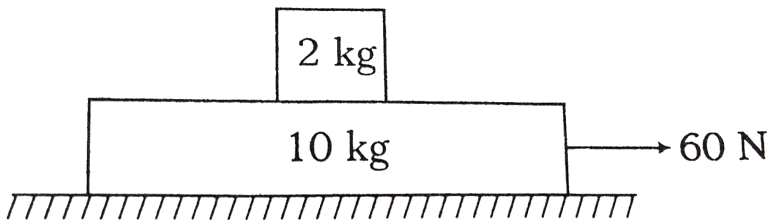

A.  $-100J$

B. 100 J

C. zero

D. 200 J

**Answer: B**



**Watch Video Solution**

**66.** A block of mass 5 kg slides down a rough inclined surface. The angle of inclination is  $45^\circ$ . The coefficient of sliding friction is 0.20. When the block slides 10 cm, the work done on the block by force of friction is

A.  $-\frac{1}{\sqrt{2}}J$

B. 1J

C.  $-\sqrt{2}J$

D.  $-1J$

**Answer: A**



**Watch Video Solution**

**67.** A particle moves on the rough horizontal ground with some initial velocity  $V_0$ . If  $\frac{3}{4}$  of its kinetic energy is lost due to friction in time  $t_0$ . The coefficient of friction between the particle and the ground is.

A.  $\frac{v_0}{2gt_0}$

B.  $\frac{v_0}{4gt_0}$

C.  $\frac{3v_0}{4gt_0}$

D.  $\frac{v_0}{gt_0}$



**Answer: A**



**Watch Video Solution**

**68.** A 50 kg girl is swinging on a swing from rest. Then, the power delivered when moving with a velocity of  $2\text{m.s}^{-1}$  upwards in a direction making an angle  $60^\circ$  with the vertical is

A. 980 W

B. 490 W

C.  $490\sqrt{3}$

D. 245 W

**Answer: C**



**Watch Video Solution**

69. A bead can slide on a smooth circular wire frame of radius  $r$  which is fixed in a vertical plane. The bead is displaced slightly from the highest point of the wire frame. The speed of the bead subsequently as a function of the angle  $\theta$  made by the bead with the vertical line is

A.  $\sqrt{2gr}$

B.  $\sqrt{2gr(1 - \sin \theta)}$

C.  $\sqrt{2gr(1 - \cos \theta)}$

D.  $2\sqrt{gr}$

**Answer: C**



**Watch Video Solution**

70. A uniform chain has a mass  $M$  and length  $L$ . It is placed on a frictionless table with length  $l_0$  hanging over the edge. The chain begins to slide down. Then, the speed  $v$  with which the end slides down from the edge is given by

A.  $v = \sqrt{\frac{g}{L}(L + l_0)}$

B.  $v = \sqrt{\frac{g}{L}(L - l_0)}$

C.  $v = \sqrt{\frac{g}{L}(L^2 - l_0^2)}$

D.  $v = \sqrt{2g(L - l_0)}$

**Answer: C**



**Watch Video Solution**

71. A particle of mass  $1\text{ g}$  executes an oscillatory motion on the concave surface of a spherical dish of radius  $2\text{ m}$  placed on a

horizontal plane, Figure . If the motion of the particle begins from a point on the disc at a height of 1 cm. from the horizontal plane and coefficient of friction is 0.01 , find the total distance covered by the particle before coming to rest.

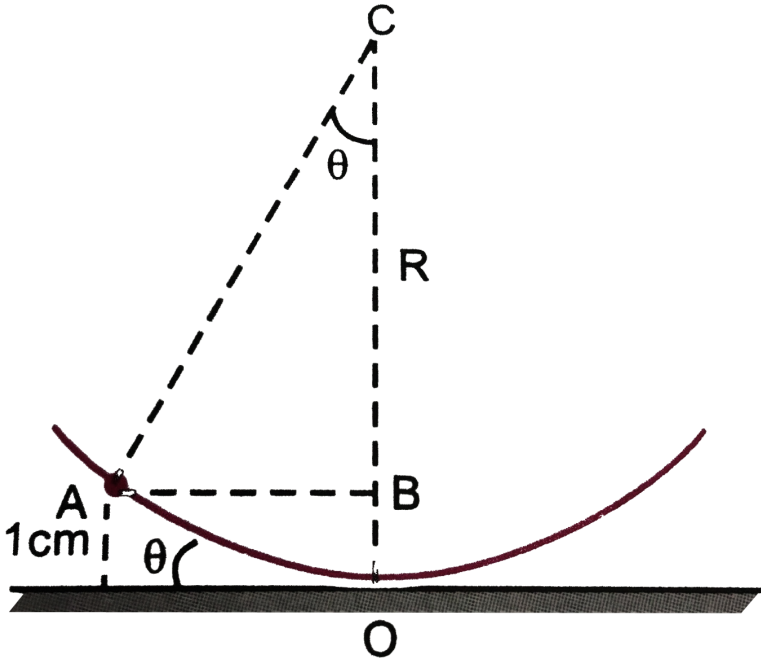

- A. 2 m
- B. 10 m
- C. 1 m
- D. 20 m

**Answer: C**



**Watch Video Solution**

**72.** A mass-spring system oscillates such that the mass moves on a rough surface having coefficient of friction  $\mu$ . It is compressed by a distance  $a$  from its normal length and, on being released, it moves to a distance  $b$  from its equilibrium position. The decrease in amplitude for one half-cycle ( $-a$  to  $b$ ) is

A.  $\frac{\mu mg}{k}$

B.  $\frac{2\mu mg}{k}$

C.  $\frac{\mu g}{k}$

D.  $\frac{k}{\mu mg}$

**Answer: B**



Watch Video Solution

**73.** A uniform flexible chain of mass  $m$  and length  $l$  hangs in equilibrium over a smooth horizontal pin of negligible diameter. One end of the chain is given a small vertical displacement so that the chain slips over the pin. The speed of chain when it leaves pin is

A.  $\sqrt{\frac{gl}{2}}$

B.  $\sqrt{gl}$

C.  $\sqrt{2gl}$

D.  $\sqrt{3gl}$

**Answer: A**



Watch Video Solution

**74.** The potential energy of a particle of mass 1 kg  $U = 10 + (x - 2)^2$ . Here, U is in joule and x in meter. On the positive x-axis particle travels up to  $x=+6$ cm. Choose the wrong statement.

- A. On negative X-axis particle travels upto  $x=-2$  m
- B. The maximum kinetic energy of the particle is 16 J
- C. Both (a) and (b) are correct
- D. Both (a) and (b) are incorrect

**Answer: C**



[Watch Video Solution](#)

**75.** A body is moving is down an inclined plane of slope  $37^\circ$  the coefficient of friction between the body and the plane varies as

$\mu = 0.3x$ , where  $x$  is the distance traveled down the plane by the body. The body will have maximum speed.  $\left( \sin 37^\circ = \frac{3}{5} \right)$ .

- a) at  $x = 1.16$  m   b) at  $x = 2$  m   c) at bottom most point of the plane  
d) at  $x = 2.5$  m

A. At  $x=1.16$  m

B. At  $x=2$  m

C. At bottom of plane

D. At  $x=2.5$  m

**Answer: D**



**Watch Video Solution**

**76.** A force of  $F=0.5$  N is applied on lower block as shown in figure. The work done by lower block on upper block for a



displacement of 3 m of the upper block with respect to ground

is (Take,  $g=10 \text{ m s}^{-2}$ )

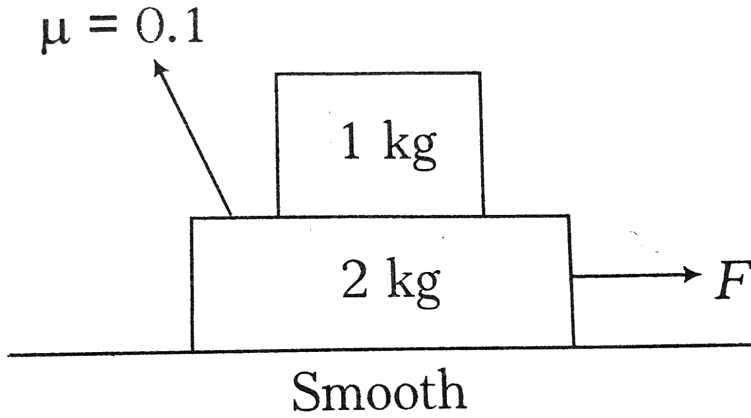

A.  $-0.5J$

B.  $0.5J$

C.  $2J$

D.  $-2J$

**Answer: B**



**Watch Video Solution**

77. A bead of mass  $\frac{1}{2}kg$  starts from rest from A to move in a vertical plane along a smooth fixed quarter ring of radius  $5m$ , under the action of a constant horizontal force  $f = 5N$  as shown. The speed of bead as it reaches the point (B) is [Take  $g = 10ms^{-2}$ ]

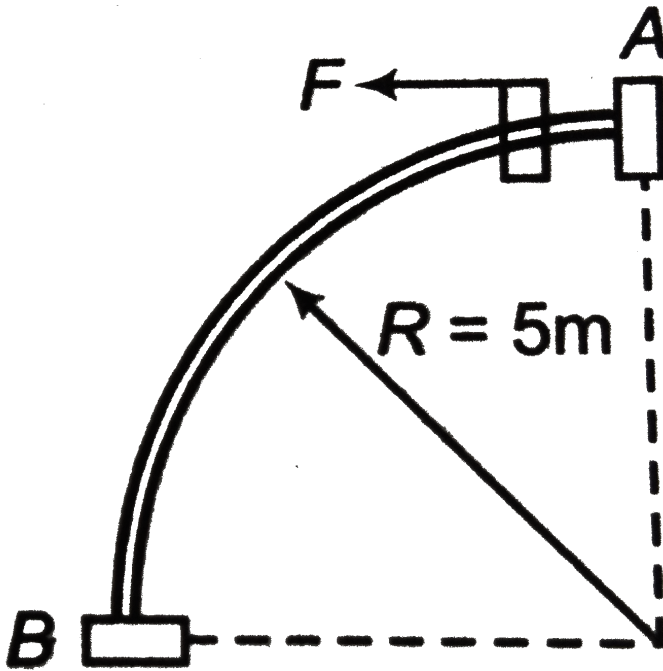

A.  $14.14ms^{-1}$

B.  $7.07ms^{-1}$

C.  $5ms^{-1}$

D.  $25ms^{-1}$

**Answer: A**



**Watch Video Solution**

**78.** A car of mass  $m$  is accelerating on a level smooth road under the action of a single  $F$ . The power delivered to the car is constant and equal to  $P$ . If the velocity of the car at an instant is

v, then after travelling how much distance it becomes double?

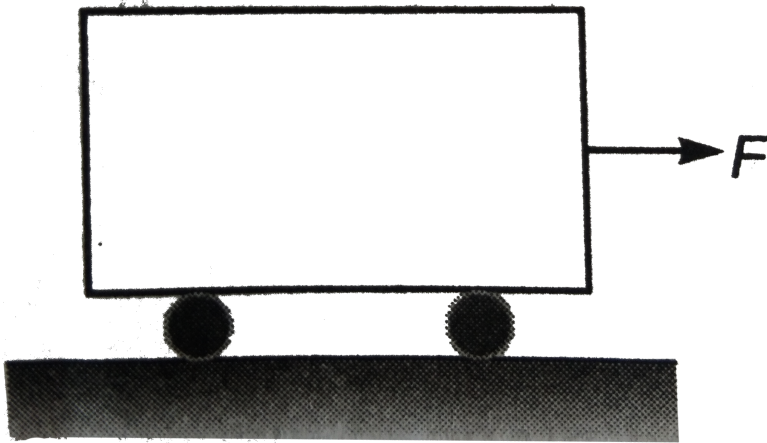

A.  $\frac{7mv^3}{3P}$

B.  $\frac{4mv^3}{3P}$

C.  $\frac{mv^3}{3P}$

D.  $\frac{18mv^3}{7P}$

**Answer: A**



**Watch Video Solution**

79. An ideal massless spring S can be compressed 1 m by a force of 100 N in equilibrium. The same spring is placed at the bottom of a frictionless plane inclined at  $30^\circ$  to the horizontal. A 10 kg block M is released from rest at the top of the incline and is brought to rest momentarily after compressing the spring by 2 m. If  $g = 10\text{ m/s}^2$ , the speed of mass just before it touches the spring is  $\sqrt{10x}\text{ m/s}$ . Find value of x?

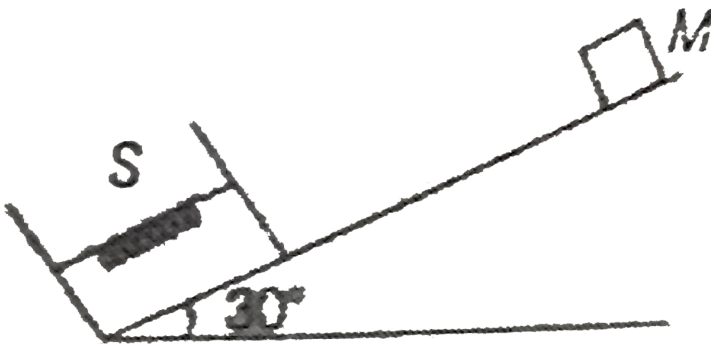

A.  $\sqrt{20}\text{ m s}^{-1}$

B.  $\sqrt{30}\text{ m s}^{-1}$

C.  $\sqrt{10}\text{ m s}^{-1}$

D.  $\sqrt{40}ms^{-1}$

**Answer: A**



**Watch Video Solution**

**80.** A pendulum of mass 1 kg and length  $l = 1$  m is released from rest at angle  $\theta = 60^\circ$ . The power delivered by all the forces acting on the bob at angle  $\theta = 30^\circ$  will be ( $g = 10m/s^2$ )

A. 13.5 W

B. 20.4 W

C. 24.6 W

D. zero

**Answer: A**



**Watch Video Solution**

**81.** A small block of mass  $m$  is kept on a rough inclined surface of inclination  $\theta$  fixed in an elevator. The elevator goes up with a uniform velocity  $v$  and the block does not slide on the wedge. The work done by the force of friction on the block in time  $t$  will be

A. zero

B.  $mgvt \cos^2 \theta$

C.  $mgvt \sin^2 \theta$

D.  $\frac{1}{2}mgvt \sin 2\theta$

**Answer: C**



**Watch Video Solution**

82. A block A of mass  $M$  rests on a wedge B of mass  $2M$  and inclination  $\theta$ . There is sufficient friction between A and B so that A does not slip on B. If there is no friction between B and ground, the compression in spring is

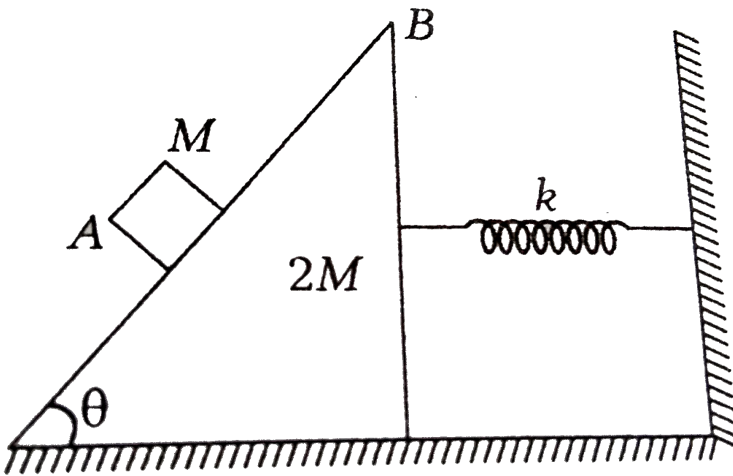

A.  $\frac{Mg \cos \theta}{k}$

B.  $\frac{Mg \cos \theta \sin \theta}{k}$

C.  $\frac{Mg \sin \theta}{k}$

D. zero



**Answer: D**



**Watch Video Solution**

**83.** In the figure -3.90 shown, the net work done by the tension when the bigger block of mass  $M$  touches the ground is :

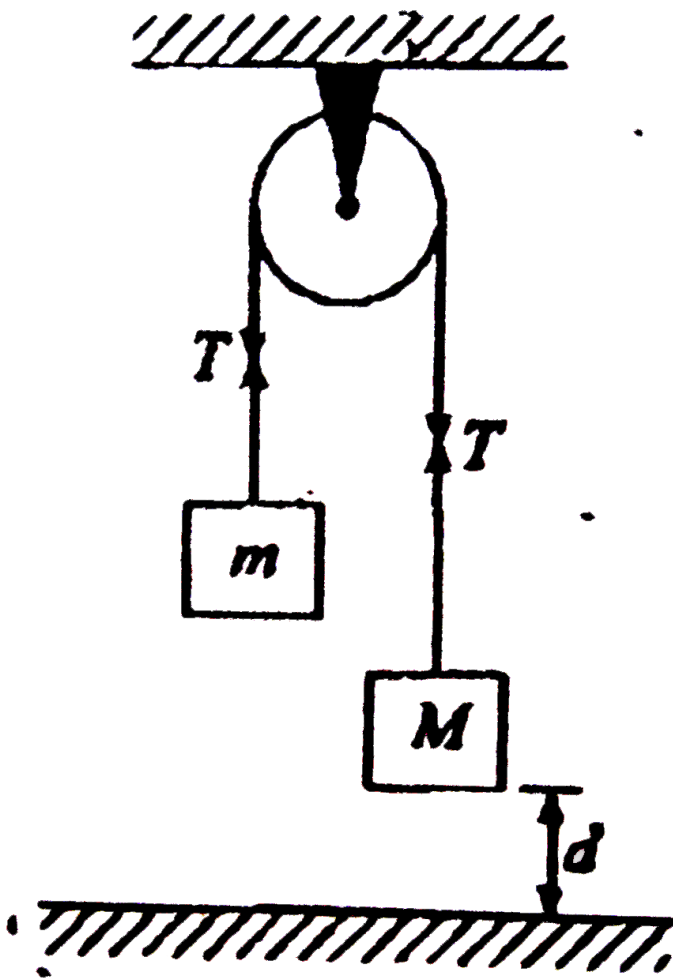

A.  $+Mgd$

B.  $-(M + m)gd$

C.  $-mgd$

D. zero

**Answer: D**



**Watch Video Solution**

## Medical Entrance Special Questions

1. These questions consists of two statements each printed as Assertion and Reason. While answering these question you are required to choose any one of the following five reponses

(a) If both Assertion and Reason are correct and Reason is the correct explanation of Asserrtion.

(b) If both Assertion and Reason are correct but Reason is not the correct explanation of Assertion.

(c ) If Assertion is true but Reason is false.

(d) If Assertion is false but Reason is true.

Assertion . Work done by constant force is equal to magnitude

of force multiplied by displacement.

Reason. Work done is scalar quantity. It may be positive, negative or zero.



[Watch Video Solution](#)

2. These questions consist of two statements each printed as Assertion and Reason. While answering these questions you are required to choose any one of the following five responses

(a) If both Assertion and Reason are correct and Reason is the correct explanation of Assertion.

(b) If both Assertion and Reason are correct but Reason is not the correct explanation of Assertion.

(c) If Assertion is true but Reason is false.

(d) If Assertion is false but Reason is true.

Assertion. Velocity of a block changes from  $(2\hat{i} + 3\hat{j}) \text{ m s}^{-1}$  to  $(-4\hat{i} - 6\hat{j}) \text{ m s}^{-1}$ . Then, work done by all the forces during

this interval of time is positive.

Reason Speed of block is increasing.



[Watch Video Solution](#)

3. These questions consists of two statements each printed as Assertion and Reason. While answering these question you are required to choose any one of the following five reponses

(a) If both Assertion and Reason are correct and Reason is the correct explanation of Asserrtion.

(b) If both Assertion and Reason are correct but Reason is not the correct explanation of Assertion.

(c) If Assertion is true but Reason is false.

(d) If Assertion is false but Reason is true.

Assertion Spring force is a conservative force.

Reason Potential energy is defined only for conservative forces.



[Watch Video Solution](#)

4. These questions consists of two statements each printed as Assertion and Reason. While answering these question you are required to choose any one of the following five reponses

- (a) If both Assertion and Reason are correct and Reason is the correct explanation of Assertion.
- (b) If both Assertion and Reason are correct but Reason is not the correct explanation of Assertion.
- (c) If Assertion is true but Reason is false.
- (d) If Assertion is false but Reason is true.

Assertion Consider a person of mass 80 kg who is climbing a ladder. In climbing up a vertical distance of 5 m, the contact force exerted by ladder on person's feet does 4000 J of work.

[Consider  $g=10 \text{ m s}^{-2}$ ]

Reason Work done by a force F is defined as the dot product of force with the displacement of point of application of force.



5. These questions consists of two statements each printed as Assertion and Reason. While answering these question you are required to choose any one of the following five reponses

(a) If both Assertion and Reason are correct and Reason is the correct explanation of Assertion.

(b) If both Assertion and Reason are correct but Reason is not the correct explanation of Assertion.

(c) If Assertion is true but Reason is false.

(d) If Assertion is false but Reason is true. Assertion The work done in bringing a body down from the top to the base along a frictionless inclined plane is the same as the work done in bringing it down from the vertical side.

Reason The gravitational force on the body along the inclined plane is the same as that along the vertical side.

6. These questions consists of two statements each printed as Assertion and Reason. While answering these question you are required to choose any one of the following five reponses

(a) If both Assertion and Reason are correct and Reason is the correct explanation of Asserrtion.

(b) If both Assertion and Reason are correct but Reason is not the correct explanation of Assertion.

(c ) If Assertion is true but Reason is false.

(d) If Assertion is false but Reason is true.

Assertion If a force is applied on a rigid body. Body is in motion but point of application of force is stationary. Then, work done by the force is zero.

Reason If body is moving, then point of application of force should also move.



7. These questions consists of two statements each printed as Assertion and Reason. While answering these question you are required to choose any one of the following five reponses

(a) If both Assertion and Reason are correct and Reason is the correct explanation of Asserrtion.

(b) If both Assertion and Reason are correct but Reason is not the correct explanation of Assertion.

(c ) If Assertion is true but Reason is false.

(d) If Assertion is false but Reason is true.

Assertion At stable equilibrium position of a body, kinetic energy cannot be zero. Because it is maximum.

Reason During oscillations of a body, potential energy is minimum at stable equilibrium position.

8. These questions consists of two statements each printed as Assertion and Reason. While answering these question you are required to choose any one of the following five reponses

(a) If both Assertion and Reason are correct and Reason is the correct explanation of Assertion.

(b) If both Assertion and Reason are correct but Reason is not the correct explanation of Assertion.

(c) If Assertion is true but Reason is false.

(d) If Assertion is false but Reason is true.

Assertion If work done by conservative force is negative, then potential energy associated with that force should increase.

Reason This is according to the relation

$$\Delta U = -W$$

Here,  $\Delta U$  is change in potential energy and  $W$  is work done by conservative force.

9. These questions consists of two statements each printed as Assertion and Reason. While answering these question you are required to choose any one of the following five reponses

(a) If both Assertion and Reason are correct and Reason is the correct explanation of Asserrtion.

(b) If both Assertion and Reason are correct but Reason is not the correct explanation of Assertion.

(c ) If Assertion is true but Reason is false.

(d) If Assertion is false but Reason is true. Assertion A body is moving along X-axis. Force  $F = - 2x^2$  is acting on it and work done by this force in moving the body from  $x=-2$  to  $x=+2$  is zero.

Reason From  $x=-2$  to  $x=0$ , work done is negative and from  $x=0$  to  $x=+2$ , work done is negative.

**10.** These questions consists of two statements each printed as Assertion and Reason. While answering these question you are required to choose any one of the following five reponses

(a) If both Assertion and Reason are correct and Reason is the correct explanation of Asserrtion.

(b) If both Assertion and Reason are correct but Reason is not the correct explanation of Assertion.

(c ) If Assertion is true but Reason is false.

(d) If Assertion is false but Reason is true.

Assertion An object A is dropped from the top of an incline at  $t=0$ , as shown. It will fall under gravity as indicated by the arrow.

At the same time, i.e.,  $t=0$ , another object B begins to slide down the frictionless incline.

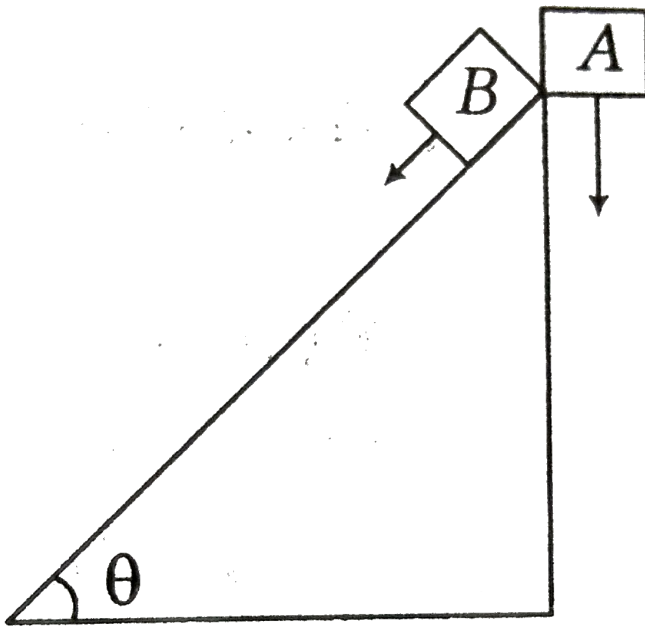

The two objects during their motion to the ground level will be travelling at equal speeds.

Reason Net force on both the objects during their motion is same.

 [Watch Video Solution](#)

11. These questions consists of two statements each printed as Assertion and Reason. While answering these question you are required to choose any one of the following five reponses

(a) If both Assertion and Reason are correct and Reason is the correct explanation of Assertion.

(b) If both Assertion and Reason are correct but Reason is not the correct explanation of Assertion.

(c) If Assertion is true but Reason is false.

(d) If Assertion is false but Reason is true.

Assertion If the surface between the blocks A and B is rough, then work done by friction on block B is always negative.

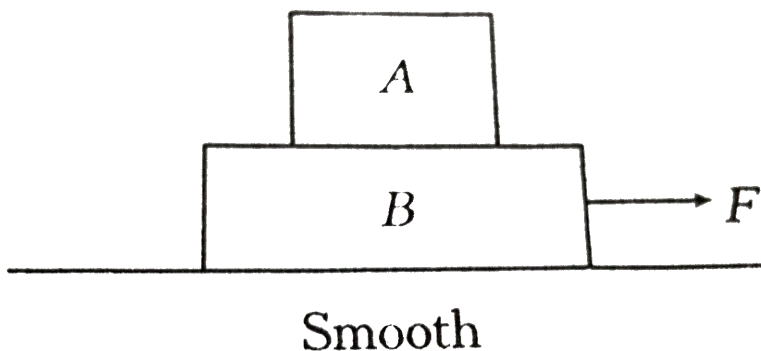

Reason Total work done by friction in both the blocks is always zero.



[Watch Video Solution](#)

**12.** These questions consists of two statements each printed as Assertion and Reason. While answering these question you are required to choose any one of the following five reponses

(a) If both Assertion and Reason are correct and Reason is the correct explanation of Asserrtion.

(b) If both Assertion and Reason are correct but Reason is not the correct explanation of Assertion.

(c ) If Assertion is true but Reason is false.

(d) If Assertion is false but Reason is true.

Assertion Force applied on a block moving in one dimension is producing a constant power, then the motion should be uniformly accelerated.

Reason This constant power multiplied with time is equal to the change in kinetic energy.



[Watch Video Solution](#)

**13.** These questions consists of two statements each printed as Assertion and Reason. While answering these question you are required to choose any one of the following five reponses

(a) If both Assertion and Reason are correct and Reason is the correct explanation of Asserrtion.

(b) If both Assertion and Reason are correct but Reason is not the correct explanation of Assertion.

(c ) If Assertion is true but Reason is false.

(d) If Assertion is false but Reason is true.

Assertion A block of mass  $m$  starts moving on a rough horizontal surface with a velocity  $v$ . It stops due to friction between the block and the surface after moving through a



certain distance.

The surface is now tilted to an angle of  $30^\circ$  with the horizontal and the same block is made to go up on the surface with the same initial velocity  $v$ . The decrease in the mechanical energy in the second situation is smaller than that in the first situation.

Reason The coefficient of friction between the block and the surface decreases with the increase in the angle of inclination.



[Watch Video Solution](#)

**14.** These questions consists of two statements each printed as Assertion and Reason. While answering these question you are required to choose any one of the following five reponses

(a) If both Assertion and Reason are correct and Reason is the correct explanation of Asserrtion.

(b) If both Assertion and Reason are correct but Reason is not the correct explanation of Assertion.

(c ) If Assertion is true but Reason is false.

(d) If Assertion is false but Reason is true.

Assertion Total work done by spring may be positive ,negative or zero.

Reason Direction of spring force is always towards mean position.



[Watch Video Solution](#)

**15.** These questions consists of two statements each printed as Assertion and Reason. While answering these question you are required to choose any one of the following five reponses

(a) If both Assertion and Reason are correct and Reason is the correct explanation of Asserrtion.

(b) If both Assertion and Reason are correct but Reason is not the correct explanation of Assertion.

(c ) If Assertion is true but Reason is false.

(d) If Assertion is false but Reason is true.

**Assertion** In projectile motion, the rate of change in magnitude of potential energy of a particle first decreases and then increases during motion.

**Reason** In projectile motion, the rate of change in linear momentum of a particle remains constant during motion.



[Watch Video Solution](#)

**16.** These questions consists of two statements each printed as Assertion and Reason. While answering these question you are required to choose any one of the following five reponses

(a) If both Assertion and Reason are correct and Reason is the correct explanation of Asserrtion.

(b) If both Assertion and Reason are correct but Reason is not the correct explanation of Assertion.

(c ) If Assertion is true but Reason is false.

(d) If Assertion is false but Reason is true.

**Assertion** At any instant the magnitude of rate of change of potential energy of the projectile of mass 1 kg is numerically equal to magnitude of  $a.v$  (where  $a$  is acceleration due to gravity and  $v$  is velocity at that instant)

**Reason** The graph representing power delivered by the gravitational force acting on the projectile with time will be straight line with negative slope.



[Watch Video Solution](#)

**Match The Columns**

## 1. Match the following columns.

Column I		Column II	
(A) Work done by all forces	(p) Negative of change in potential energy		
(B) Work done by conservative forces	(q) Change in kinetic energy		
(C) Work done by external forces	(r) Change in mechanical energy		
	(s) None		



Watch Video Solution

## 2. Match the appropriate sign of given potential energy is following with column II.

Column I		Column II	
(A) Electrostatic potential energy	(p) Positive		
(B) Gravitational potential energy	(q) Negative		
(C) Elastic potential energy	(r) zero		
(D) Magnetic potential energy	(s) Not defined		



Watch Video Solution

3. A force  $F=kx$  (where  $k$  is a positive constant) is acting on a particle Work done:

Column-1

Column-2

- |  |              |
|--|--------------|
| (A) in displacing the body from $x=2$ to $x=4$   | (P) Negative |
| (B) In displacing the body from $x=-4$ to $x=-2$ | (Q) Positive |
| (C) In displacing the body from $x=-2$ to $x=+2$ | (R) Zero     |

 [Watch Video Solution](#)

4. A body is moved along a straight line by a machine delivering a power proportional to time ( $P \propto t$ ). Then, match the following.

Table-1	Table-2
(A) Velocity is proportional to	(P) $t$
(B) Displacement is proportional to	(Q) $t^2$
(C) Work done is proportional to	(R) $t^3$

 [Watch Video Solution](#)

5. Acceleration versus  $x$  and potential energy versus  $x$  graph of a particle moving along  $x$ -axis is as shown in figure. Mass of the particle is 1 kg and velocity at  $x = 0$  is  $4\text{ m/s}$ . Match the following at  $x = 8\text{ m}$ .

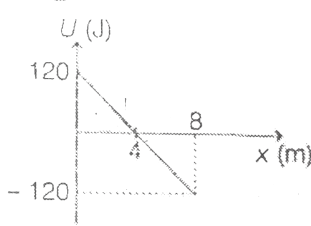
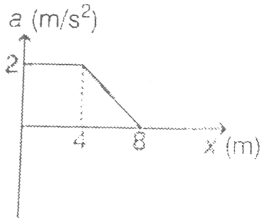

Table-1	Table-2
(A) Kinetic energy	(P) 120 J
(B) Work done by conservative forces	(Q) 240 J
(C) Total work done	(R) 128 J
(D) Work done by forces other than gravity	(S) 112 J
	(T) None



**Watch Video Solution**

6.  $F$ - $x$  and corresponding  $U$ - $x$  graphs are as shown in figure.

Three point A, B and C in  $F$ - $x$  graph may be corresponding to P, Q

and R in the U-x graph. Match the following

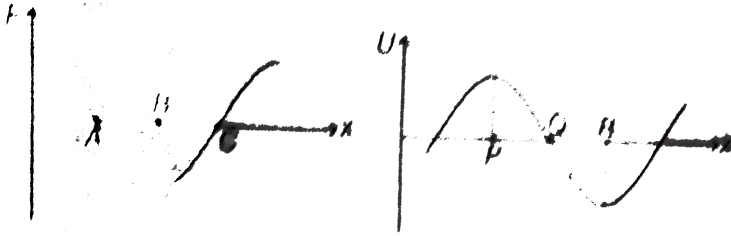

Table-1

Table-2

(A) A

(P) P

(B) B

(Q) Q

(C) C

(R) R

(S) None



Watch Video Solution

7. A block of mass  $m$  is stationary with respect to a rough wedge as shown in figure. Starting from rest in time  $t$ , ( $m = 1 \text{ kg}$ ,  $\theta = 30^\circ$ ,  $a = 2m/s^2$ ,  $t = 4 \text{ s}$ ) work done on block :



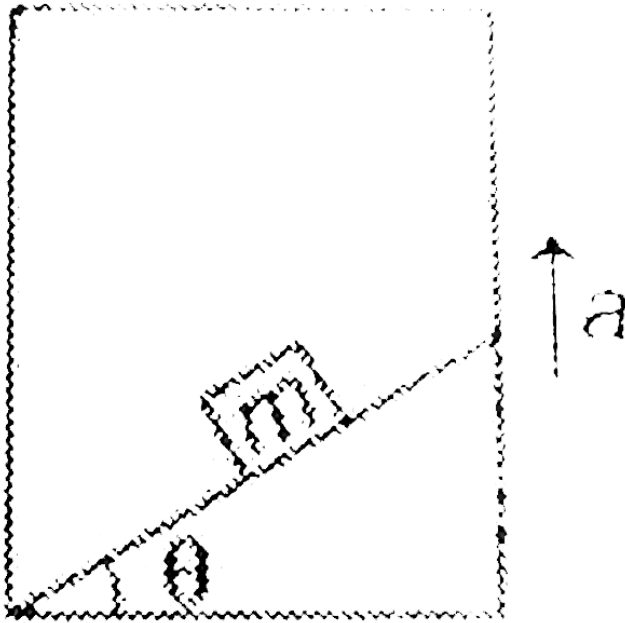

Table-1	Table-2
(A) By gravity	(P) 144J
(B) By normal reaction	(Q) 32J
(C) By friction	(R) 56J
(D) By all the forces	(S) 48J
	(T) None



**Watch Video Solution**

1. A body of mass  $1\text{ kg}$  begins to move under the action of a time dependent force  $\vec{F} = (2t\hat{i} + 3t^2\hat{j})\text{ N}$ , where  $\hat{i}$  and  $\hat{j}$  are unit vectors along x-and y-axes. What power will be developed by the force at the time  $t$  ?

A.  $(2t^2 + 4t^4)\text{ W}$

B.  $(2t^3 + 3t^4)\text{ W}$

C.  $(2t^3 + 3t^5)\text{ W}$

D.  $(2t + 3t^3)\text{ W}$

**Answer: C**



**Watch Video Solution**

2. A particle of mass  $10\text{ g}$  moves along a circle of radius  $6.4\text{ cm}$  with a constant tangential acceleration. What is the magnitude

of this acceleration, if the kinetic energy of the particle becomes equal to  $8 \times 10^{-4} \text{ J}$  by the end of the second revolution after the beginning of the motion?

A.  $0.15 \text{ ms}^{-2}$

B.  $0.18 \text{ ms}^{-2}$

C.  $0.2 \text{ ms}^{-2}$

D.  $0.1 \text{ ms}^{-2}$

**Answer: D**



[Watch Video Solution](#)

3. A block of mass  $10 \text{ kg}$ , moving in  $x$ -direction with a constant speed of  $10 \text{ ms}^{-1}$ , is subjected to a retarding force

$F = 0.1 \times J/m$  during its travel from  $x=20$  m to 30 m. Its final

KE will be

A. 475 J

B. 450 J

C. 275 J

D. 250 J

**Answer: A**



[Watch Video Solution](#)

4. A particle of mass  $m$  is driven by a machine that delivers a constant power  $k$  watts. If the particle starts from rest the force on the particle at time  $t$  is

A.  $\sqrt{\frac{mk}{2}} t^{-1/2}$

B.  $\sqrt{mk} t^{-1/2}$

C.  $\sqrt{2mk} t^{-1/2}$

D.  $\frac{1}{2}\sqrt{mk} t^{-1/2}$

**Answer: A**



**Watch Video Solution**

5. A block of mass  $m = 11.7 \text{ kg}$  is to be pushed a distance of  $s = 4.65 \text{ m}$ . Assuming frictionless surface. Calculate the work done in applying a force parallel to the incline to push the block up at a

constant speed. (Take,  $g=9.8 \text{ m s}^{-2}$ )

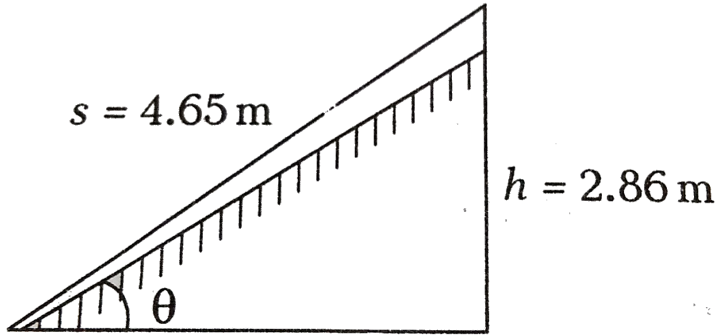

- A. 328 J
- B. 656 J
- C. 164 J
- D. 530 J

**Answer: A**



**Watch Video Solution**

6. A force  $F = (10 + 0.50x)$  acts on a particle in the x direction, where F is in newton and x in meter. Find the work done by this force during a displacement from  $x=0$  to  $x=2.0\text{m}$

A. 31.5 J

B. 63 J

C. 21 J

D. 42 J

**Answer: C**



[Watch Video Solution](#)

7. An elevator weighing 500 kg is to be lifted up at a constant velocity of 0.20 m/s. What would be the minimum horsepower of the motor to be used?

A.  $10.30hp$

B.  $5.15hp$

C.  $2.62 hp$

D.  $1.31 hp$

**Answer: D**



**Watch Video Solution**

8. The distance of closest approach of an  $\alpha$ -particle fired at nucleus with momentum  $p$  is  $d$ . The distance of closest approach when the  $\alpha$ -particle is fired at same nucleus with momentum  $3p$  will be

A.  $3d$

B.  $\frac{d}{3}$



C.  $9d$

D.  $\frac{d}{9}$

**Answer: D**



**Watch Video Solution**

**9.** Two bodies of different masses are moving with same kinetic energy. Then, the ratio of their moment is equal to the ratio of their

A. masses

B. square of masses

C. square root of masses

D. cube root of masses

**Answer: C**



**Watch Video Solution**

**10.** Two bodies of masses 1 kg and 2 kg moving with same velocities are stopped by the same force. Then, the ratio of their stopping distances is

A. 1 : 2

B. 2 : 1

C.  $\sqrt{2}$  : 1

D. 1 :  $\sqrt{2}$

**Answer: A**



**Watch Video Solution**

11. One moving electron when comes closer to other stationary electron, then its kinetic energy and potential energy respectively.....and.....

- A. increases, increases
- B. increases, decreases
- C. decreases, increases
- D. decreases, decreases

**Answer: C**



[Watch Video Solution](#)

12. A body of mass  $m$ , accelerates uniformly from rest to  $V_1$  in time  $t_1$ . The instantaneous power delivered to the body as a function of time  $t$  is.

A.  $\frac{mv_1t}{t_1}$

B.  $\frac{mv_1t}{t_1}$

C.  $\frac{mv_1t^2}{t_1}$

D.  $\frac{mv_1^2t}{t_1^2}$

**Answer: D**



**Watch Video Solution**

**13.** A uniform chain of length  $l$  is placed on a smooth horizontal table, such that half of its length hangs over one edge. It is released from rest, the velocity with which it leaves the table is

A.  $\sqrt{\frac{3gl}{4}}$

B.  $\sqrt{\frac{3gl}{2}}$

C.  $\sqrt{\frac{2gl}{3}}$

D.  $\sqrt{\frac{gl}{3}}$

**Answer: A**



**Watch Video Solution**

**14.** The kinetic energy of a body of mass 4 kg and momentum 6

N-s will be

A. 4.5 J

B. 2.5 J

C. 5.5 J

D. 3.5 J

**Answer: A**



**Watch Video Solution**

15. A body of mass  $m=3.90$  kg slides on a horizontal frictionless table with a speed of  $v=120 \text{ m s}^{-1}$ . It is brought to rest in compressing a spring in its path. How much does spring is compressed, if its force constant  $k$  is  $135 \text{ Nm}^{-1}$ ?

A. 0.204 m

B. 0.408 m

C. 0.804 m

D. 4.04 m

**Answer: A**



**Watch Video Solution**

16. A string of length  $L$  and force constant  $k$  is stretched to obtain extension  $l$ . It is further stretched to obtain extension  $l_1$ .

The work done in second stretching is

A.  $\frac{1}{2}kl_1(2l + l_1)$

B.  $\frac{1}{2}kl_1^2$

C.  $\frac{1}{2}k(l^2 + l_1^2)$

D.  $\frac{1}{2}k(l_1^2 - l^2)$

**Answer: A**



**Watch Video Solution**

17. A body is initially at rest. It undergoes one dimensional motion with constant acceleration. The power delivered to it at time  $t$  is proportional to

A.  $t_{1/2}$

B.  $t$

C.  $t^{3/2}$

D.  $t^2$

**Answer: B**



**Watch Video Solution**

**18.** If two person A and B take 2 s and 4 s, respectively to lift an object to the same height  $h$ , then the ratio of their powers is

A. 1 : 2

B. 1 : 1

C. 2 : 1



D. 1 : 3

**Answer: C**



[Watch Video Solution](#)

19. If , a machine gun fires  $n$  bullets per second each with kinetic energy  $K$ , then the power of the machine gun is

A.  $nK^2$

B.  $\frac{K}{n}$

C.  $n^2K$

D.  $nk$

**Answer: D**



[Watch Video Solution](#)

20. A uniform force of  $(3\hat{i} + \hat{j})$  N acts on a particle of mass 2kg. Hence, the particle is displaced from position  $(2\hat{i} + \hat{k})$ m to position  $(4\hat{i} + 3\hat{j} - \hat{k})$ m. The work done by the force on the particle is

A. 9 J

B. 6 J

C. 13 J

D. 15 J

**Answer: A**



**Watch Video Solution**

21. The power ( $P$ ) of an engine lifting a mass of 100 kg up to a height of 10 m in 1 min is

A.  $P=163.3 \text{ W}$

B.  $P=9800 \text{ W}$

C.  $P=10000 \text{ W}$

D.  $P=5000 \text{ W}$

**Answer: A**



[Watch Video Solution](#)

22. A body of mass  $300 \text{ kg}$  is moved through  $10 \text{ m}$  along a smooth inclined plane of inclination angle  $30^\circ$ . The work done in moving (in joules) is ( $g = 9.8 \text{ ms}^{-2}$ ).

A. 4900

B. 9800

C. 14700

D. 2450

**Answer: D**



**Watch Video Solution**

**23.** Force constant of two wires  $A$  and  $B$  of the same material are  $K$  and  $2K$  respectively. If the two wires are stretched equally, then the ratio of work done in stretching  $\left(\frac{W_A}{W_B}\right)$  is

A.  $\frac{1}{3}$

B.  $\frac{1}{3}$

C.  $\frac{1}{2}$

D.  $\frac{1}{4}$

**Answer: B**



**Watch Video Solution**

**24.** A truck accelerates from speed  $v$  to  $2v$ . Work done in during this is

- A. three times as the work done in accelerating it from rest to  $v$
- B. same as the work done in accelerating it from rest to  $v$
- C. four times as the work done in accelerating it from rest to  $v$
- D. less than the work done in accelerating it from rest to  $v$

**Answer: A**



**Watch Video Solution**

**25.** A block of 200 g mass is dropped from a height of 2 m on to a spring and compress the spring to a distance of 50 cm. The force constant of the spring is

A.  $20Nm^{-1}$

B.  $40Nm^{-1}$

C.  $30Nm^{-1}$

D.  $60Nm^{-1}$

**Answer: B**



**Watch Video Solution**

26. Work done in time  $t$  on a body of mass  $m$  which is accelerated from rest to a speed  $v$  in time  $t_1$  as a function of time  $t$  is given by

A.  $\frac{1}{2}m \frac{v^2}{t_1^2} t^2$

B.  $\frac{1}{2} \left( \frac{mv}{t_1} \right)^2 t^2$

C.  $m \frac{v}{t_1} t^2$

D.  $\frac{1}{2}m \frac{v}{t} t^2$

**Answer: A**



**Watch Video Solution**

27. The slope of kinetic energy displacement curve of a particle in motion is

- A. equal to the acceleration of the particle
- B. directly proportional to the acceleration of the particle
- C. inversely proportional to the acceleration of the particle
- D. None of the above

**Answer: B**



**Watch Video Solution**

**28.** The potential energy of a particle in a force field is  $U = \frac{A}{r^2} - \frac{B}{r}$ , where A and B are positive constants and r is the distance of particle from the centre of the field. For stable equilibrium, the distance of the particle is

A.  $B/2A$

B.  $2A/B$



C.  $A/B$

D.  $B/A$

**Answer: B**

 [Watch Video Solution](#)

29. Two masses  $m$  and  $2m$  are attached to two ends of an ideal spring as shown in figure. When the spring is in the compressed state, the energy of the spring is 60 J, if the spring is released, then at its natural length

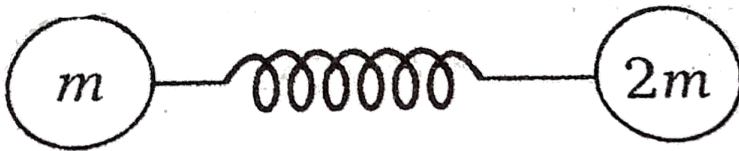

A. energy of smaller body will be 20 J

B. energy of smaller body will be 40 J

C. energy of smaller body will be 10 J

D. energy of both the bodies will be same

**Answer: B**



**Watch Video Solution**

**30.** The power of pump, which can pump 200 kg of water to a height of 50 m in 10 sec, will be

A.  $4 \times 10^3 W$

B.  $10 \times 10^3 W$

C.  $20 \times 10^3 W$

D. None of these

**Answer: A**

 [Watch Video Solution](#)

31. An automobile of mass  $m$  accelerates from rest. If the engine supplies a constant power  $P$ , the velocity at time  $t$  is given by -

A.  $\frac{2Pt}{M}$

B.  $\sqrt{\frac{2Pt}{m}}$

C.  $\frac{Pt}{2M}$

D.  $\sqrt{\frac{Pt}{2M}}$

**Answer: B**

 [Watch Video Solution](#)

32. How much work must work be done by a force on 50 kg body in order to accelerate it in the direction of force from rest to

$20ms^{-1}$  is  $10\text{ s}$ ?

A.  $10^3 J$

B.  $10^4 J$

C.  $2 \times 10^3 J$

D.  $4 \times 10^4 J$

**Answer: B**



**Watch Video Solution**

**33.** Under the action of a force  $F = Cx$ , the position of a body changes from 0 to  $x$ . The work done is

A.  $\frac{1}{2}Cx^2$

B.  $Cx^2$

C.  $Cx$

D.  $\frac{1}{2}Cx$

**Answer: A**



**Watch Video Solution**