



PHYSICS

BOOKS - PSEB

MECHANICAL PROPERTIES OF FLUIDS

Exercise

1. Explain why The blood pressure in humans is greater at the feet than at the brain?

 [Watch Video Solution](#)

2. Explain why Atmospheric pressure at a height of about 6 km decreases to nearly half of its value at the sea level, though the height of the atmosphere is more than 100 km



[Watch Video Solution](#)

3. Explain why Hydrostatic pressure is a scalar quantity even though pressure is force divided by area.



[Watch Video Solution](#)

4. Explain why The angle of contact of mercury with glass is obtuse, while that of water with glass is acute.



[Watch Video Solution](#)

5. Explain why Water on a clean glass surface tends to spread out while mercury on the same surface tends to form drops. (Put differently, water wets glass while mercury does not.)



[Watch Video Solution](#)

6. Explain why Surface tension of a liquid is independent of the area of the surface

 [Watch Video Solution](#)

7. Explain why Water with detergent dissolved in it should have small angles of contact.

 [Watch Video Solution](#)

8. Explain why A drop of liquid under no external forces is always spherical in shape.

 [Watch Video Solution](#)

9. Fill in the blanks using the word(s) from the list appended with each statement: Surface tension of liquids generally . . . with temperatures (\in *creases* / *decreases*)



[Watch Video Solution](#)

10. Fill in the blanks using the word(s) from the list appended with each statement: Viscosity of gases . . . With temperature, whereas viscosity of liquids . . . With temperature (\in *creases / decreases*)



[Watch Video Solution](#)

11. Fill in the blanks using the word(s) from the list appended with each statement: For solids with elastic modulus of rigidity, the shearing force is proportional to ... , while for fluids it is proportional to . . . (*shearstra \in / rateofshearstra \in*)



[Watch Video Solution](#)

12. Fill in the blanks using the word(s) from the list appended with each statement: For a fluid in a steady flow, the increase in flow speed at a constriction foliows (*conservationofmass / Bernoli' spr \in cip \leq*)



[Watch Video Solution](#)

13. Fill in the blanks using the word(s) from the list appended with each statement: For the model of a plane in a wind tunnel, turbulence occurs at a ... speed for turbulence for an actual plane (*greater / small* $\leq r$)



[Watch Video Solution](#)

14. Explain why To keep a piece of paper horizontal, you should blow over, not under, it



[Watch Video Solution](#)

15. Explain why When we try to close a water tap with our fingers, fast jets of water gush through the openings between our fingers



[Watch Video Solution](#)

16. Explain why The size of the needle of a syringe controls flow rate better than the thumb pressure exerted by a doctor while administering an injection



[Watch Video Solution](#)

17. Explain why A fluid flowing out of a small hole in a vessel results in a backward thrust on the vessel



[Watch Video Solution](#)

18. Explain why A spinning cricket ball in air does not follow a parabolic trajectory



[Watch Video Solution](#)

19. A 50 kg girl wearing high heel shoes balances on a single heel. The heel is circular with a diameter 1.0 cm. What is the pressure exerted by

the heel on the horizontal floor ?



[Watch Video Solution](#)

20. Toricelli's barometer used mercury. Pascal duplicated it using French wine of density 984 kg m^{-3} . Determine the height of the wine column for normal atmospheric pressure.



[Watch Video Solution](#)

21. A vertical off-shore structure is built to withstand a maximum stress of 10^9 Pa. Is the structure suitable for putting up on top of an oil well in the ocean ? Take the depth of the ocean to be roughly 3 km, and ignore ocean currents.



[Watch Video Solution](#)

22. A hydraulic automobile lift is designed to lift cars with a maximum mass of 3000 kg. The area of cross-section of the piston carrying the load is 425cm^2 . What maximum pressure would the smaller piston have to bear ?



[Watch Video Solution](#)

23. A U-tube contains water and methylated spirit separated by mercury. The mercury columns in the two arms are in level with 10.0 cm of water in one arm and 12.5 cm of spirit in the other. What is the specific gravity of spirit ?



[Watch Video Solution](#)

24. In the previous problem, if 15.0 cm of water and spirit each are further poured into the respective arms of the tube, what is the difference in the levels of mercury in the two arms ? (Specific gravity of mercury = 13.6)



[Watch Video Solution](#)

25. Can Bernoulli's equation be used to describe the flow of water through a rapid in a river? Explain.



Watch Video Solution

26. Does it matter if one uses gauge instead of absolute pressure in applying Bernoulli's equation? Explain.



Watch Video Solution

27. Glycerine flows steadily through a horizontal tube of length 1.5 m and radius 1.0 cm. If the amount of glycerine collected per second at one end is $4.0 \times 10^{-3} \text{ kg s}^{-1}$, what is the pressure difference between the two ends of the tube? (Density of glycerine = $1.3 \times 10^3 \text{ kg m}^{-3}$ and viscosity of glycerine = 0.83 Pa s). [You may also like to check if the assumption of laminar flow in the tube is correct].



[Watch Video Solution](#)

28. In a test experiment on a model aeroplane in a wind tunnel, the flow speeds on the upper and lower surfaces of the wing are 70ms^{-1} and 63ms^{-1} respectively. What is the lift on the wing if its area is 2.5m^2 ?

Take the density of air to be 1.3kgm^{-3}



[Watch Video Solution](#)

29. Figures 10.23(a) and (b) refer to the steady flow of a (non-viscous) liquid. Which of the two figures is incorrect ? Why ?:

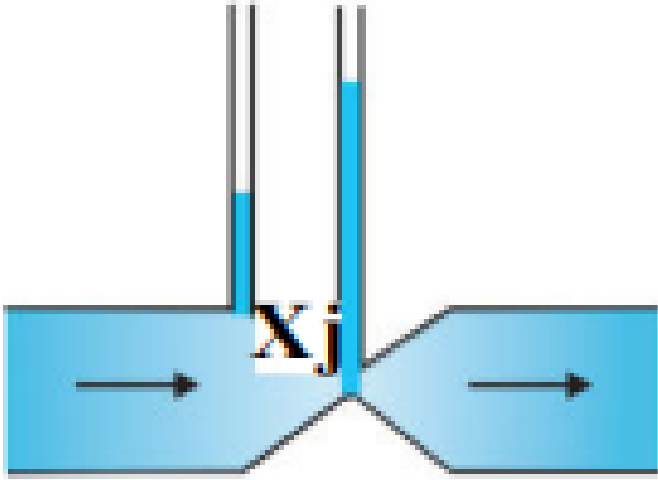

(a)

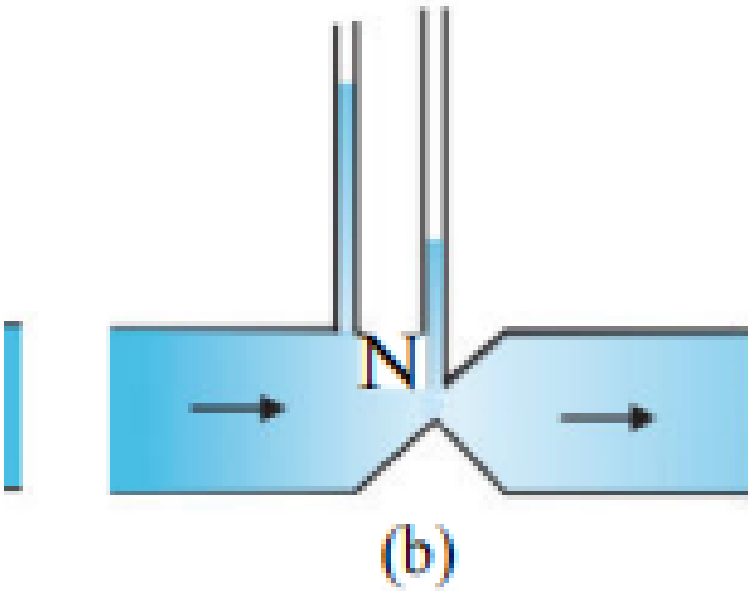

[Watch Video Solution](#)

30. The cylindrical tube of a spray pump has a cross-section of 8.0cm^2 one end of which has 40 fine holes each of diameter 1.0 mm. If the liquid flow inside the tube is 1.5m min^{-1} , what is the speed of ejection of the liquid through the holes ?

[Watch Video Solution](#)

31. A U-shaped wire is dipped in a soap solution, and removed. The thin soap film formed between the wire and the light slider supports a weight of $1.5 \times 10^{-2} \text{ N}$ (which includes the small weight of the slider). The length of the slider is 30 cm. What is the surface tension of the film ?

 [Watch Video Solution](#)

32. Figure 10.24 (a) shows a thin liquid film supporting a small weight = $4.5 \times 10^{-2} \text{ N}$. What is the weight supported by a film of the same liquid at the same temperature in Fig. (b) and (c) ? Explain your answer physically:

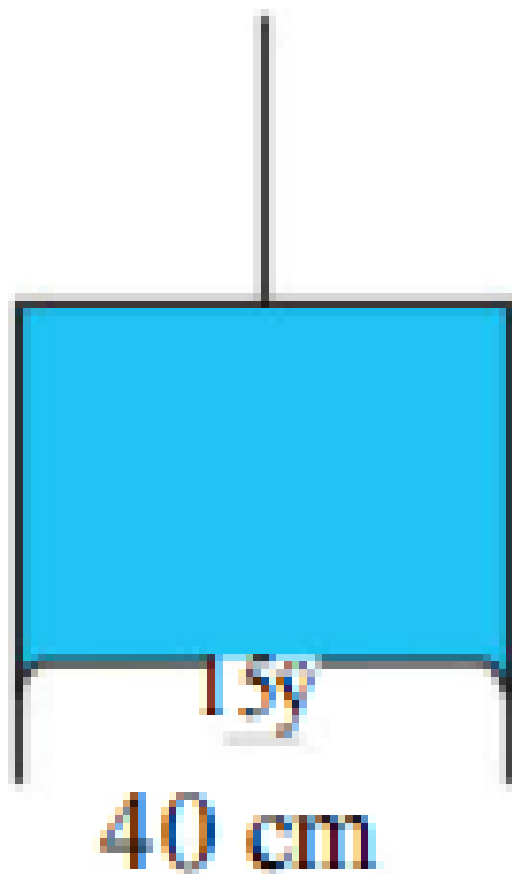

(a)

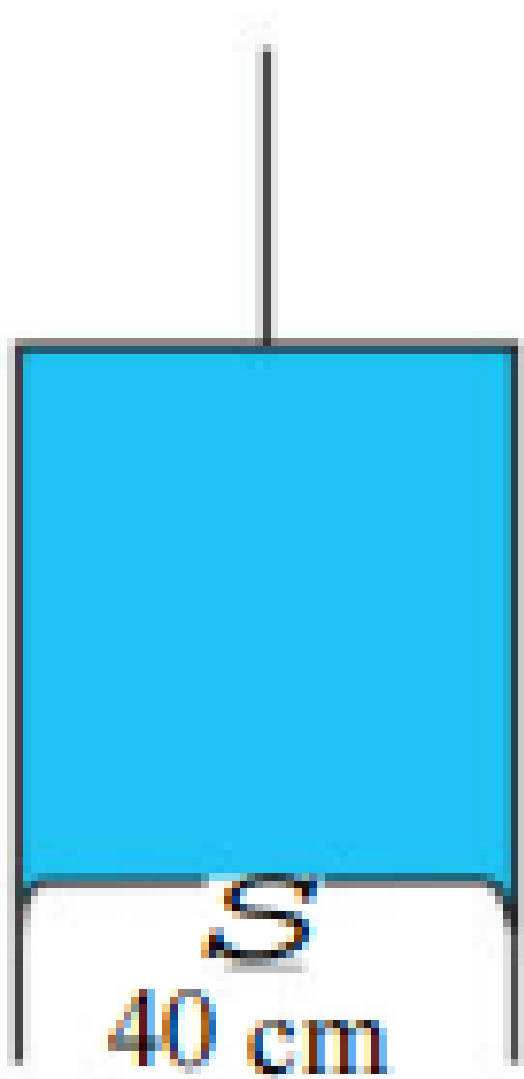

(b)

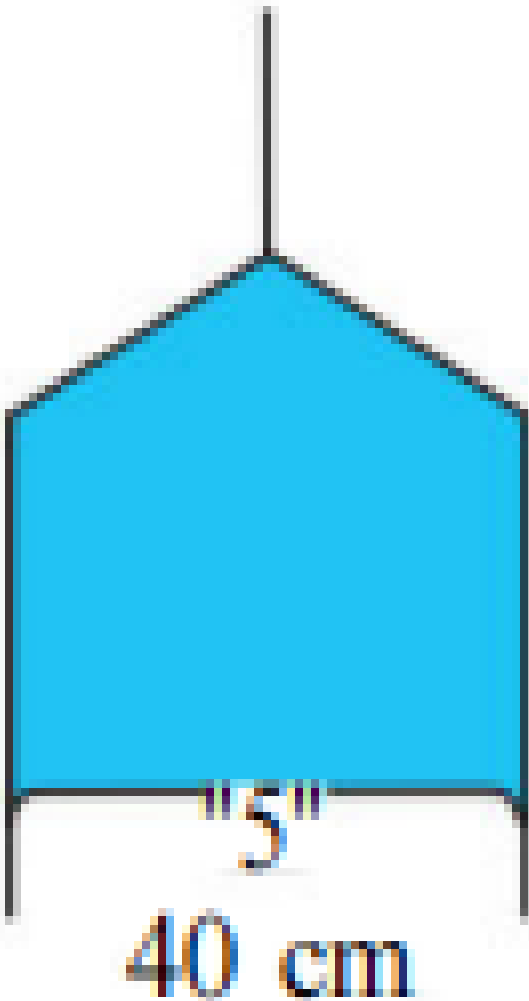

Watch Video Solution

33. What is the pressure inside the drop of mercury of radius 3.00 mm at room temperature? Surface tension of mercury at that temperature (20°C) is $4.65 \times 10^{-1} \text{Nm}^{-1}$. The atmospheric pressure is $1.01 \times 10^5 \text{Pa}$. Also give the excess pressure inside the drop.

 [Watch Video Solution](#)

34. What is the excess pressure inside a bubble of soap solution of radius 5.00 mm, given that the surface tension of soap solution at the temperature (20°C) is $2.50 \times 10^{-2} \text{N m}^{-1}$? If an air bubble of the same dimension were formed at depth of 40.0 cm inside a container containing the soap solution (of relative density 1.20), what would be the pressure inside the bubble? (1 atmospheric pressure is $1.01 \times 10^5 \text{Pa}$).

 [Watch Video Solution](#)

35. A tank with a square base of area 1.0 m^2 is divided by a vertical partition in the middle. The bottom of the partition has a small-hinged

door of area 20cm^2 . The tank is filled with water in one compartment, and an acid (of relative density 1.7) in the other, both to a height of 4.0 m. compute the force necessary to keep the door close.

 [Watch Video Solution](#)

36. A manometer reads the pressure of a gas in an enclosure as shown in Fig. 10.25 (a) When a pump removes some of the gas, the manometer reads as in Fig. 10.25 (b) The liquid used in the manometer is mercury and the atmospheric pressure is 76 cm of mercury. Give the absolute and gauge pressure of the gas in the enclosure for cases (a) and (b), in units of cm of mercury.:

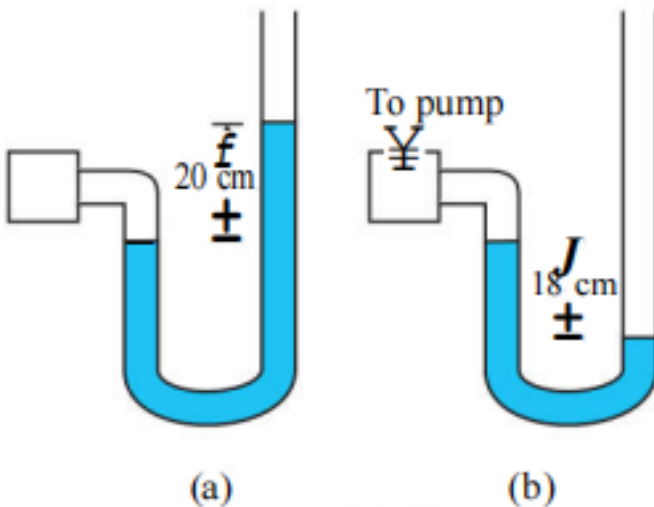

37. A manometer reads the pressure of a gas in an enclosure as shown in Fig. 10.25 (a) When a pump removes some of the gas, the manometer reads as in Fig. 10.25 (b) The liquid used in the manometer is mercury and the atmospheric pressure is 76 cm of mercury. How would the levels change in case (b) if 13.6 cm of water (immiscible with mercury) are poured into the right limb of the manometer? (Ignore the small change in the volume of the gas):

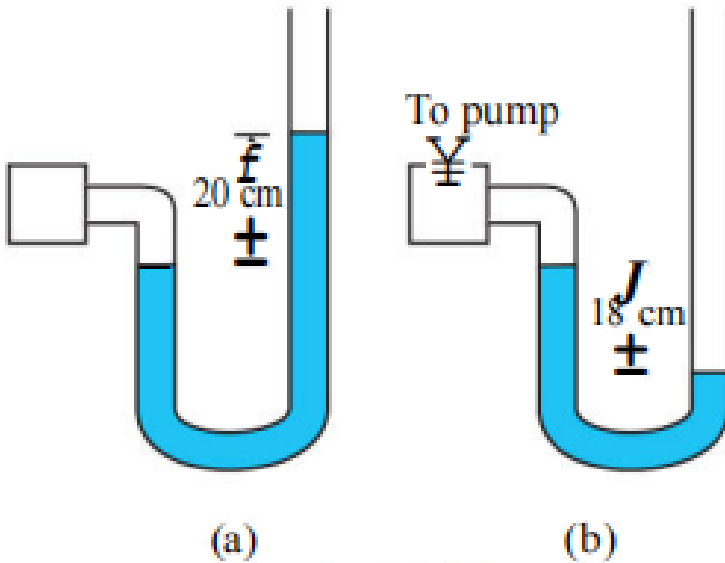

38. Two vessels have the same base area but different shapes. The first vessel takes twice the volume of water that the second vessel requires to fill upto a particular common height. Is the force exerted by the water on the base of the vessel the same in the two cases ? If so, why do the vessels filled with water to that same height give different readings on a weighing scale ?

 [Watch Video Solution](#)

39. During blood transfusion the needle is inserted in a vein where the gauge pressure is 2000 Pa. At what height must the blood container be placed so that blood may just enter the vein ? [Use the density of whole blood from Table 10.1],

 [Watch Video Solution](#)

40. In deriving Bernoulli's equation, we equated the work done on the fluid in the tube to its change in the potential and kinetic energy . What is

the largest average velocity of blood flow in an artery of diameter 2×10^{-3} m if the flow must remain laminar? Discuss qualitatively.

 [Watch Video Solution](#)

41. In deriving Bernoulli's equation, we equated the work done on the fluid in the tube to its change in the potential and kinetic energy. Do the dissipative forces become more important as the fluid velocity increases? Discuss qualitatively.

 [Watch Video Solution](#)

42. In deriving Bernoulli's equation, we equated the work done on the fluid in the tube to its change in the potential and kinetic energy. What is the largest average velocity of blood flow in an artery of diameter 2×10^{-3} m if the flow must remain laminar? Discuss qualitatively.

 [Watch Video Solution](#)

43. A plane is in level flight at constant speed and each of its two wings has an area of 25m^2 . If the speed of the air is $180\text{km}/\text{h}$ over the lower wing and $234\text{km}/\text{h}$ over the upper wing surface, determine the plane's mass. (Take air density to be 1kgm^{-3})

 [Watch Video Solution](#)

44. In Millikan's oil drop experiment, what is the terminal speed of an uncharged drop of radius $2.0 \times 10^{-5}\text{m}$ and density $1.2 \times 10^3\text{kgm}^{-3}$. Take the viscosity of air at the temperature of the experiment to be $1.8 \times 10^{-5}\text{Pa s}$. How much is the viscous force on the drop at that speed ? Neglect buoyancy of the drop due to air

 [Watch Video Solution](#)

45. Mercury has an angle of contact equal to 140° with soda lime glass. A narrow tube of radius 1.00mm made of this glass is dipped in a trough containing mercury. By what amount does the mercury dip down in the

tube relative to the liquid surface outside ? Surface tension of mercury at the temperature of the experiment is 0.465 Nm^{-1} . Density of mercury = $13.6 \times 10^3 \text{ kgm}^{-3}$.

 [Watch Video Solution](#)

46. Two narrow bores of diameters 3.0 mm and 6.0 mm are joined together to form a U-tube open at both ends. If the U-tube contains water, what is the difference in its levels in the two limbs of the tube ? Surface tension of water at the temperature of the experiment is $7.3 \times 10^{-2} \text{ Nm}^{-1}$. Take the \angle of contact \rightarrow be zero and density of water $1.0 \times 10^3 \text{ kg m}^{-3}$ ($g = 9.8 \text{ m s}^{-2}$).

 [Watch Video Solution](#)