



PHYSICS

BOOKS - HC VERMA

ELECTRIC CURRENT IN CONDUCTORS

Examples

1. An electron beam has an aperture 1.0mm^2 . A total of 6.0×10^{16} electrons go through any perpendicular cross section per second. Find (a) the current and (b) the current density in the beam.



[Watch Video Solution](#)

2. Calculate the drift speed of the electrons when 1A of current exists in a copper wire of cross section 2 mm^2 . The number of free electrons in 1cm^3 of copper is 8.5×10^{22} .

 [Watch Video Solution](#)

3. Calculate the resistance of an aluminium wire of length 50 cm and cross sectional area 2.0mm^2 . The resistivity of aluminium is $(\rho) = 2.6 \times 10^{-8}(\Omega)\text{m}$.

 [Watch Video Solution](#)

4. A resistor develops 400J of thermal energy in 10 s when a current of 2A is passed through it. (a) Find its resistance . (b) If the current is increased to 4 A, what will be the energy developed in 10 s.



[Watch Video Solution](#)

5. A battery of emf 2.0 V and internal resistance $0.50(\Omega)$ supplies a current of 100 mA. Find (a) the potential difference across the terminals of the battery and (b) the thermal energy developed in the battery in 10 s.



[Watch Video Solution](#)

6. Find the equivalent resistance of the network shown in figure between the point A and B.

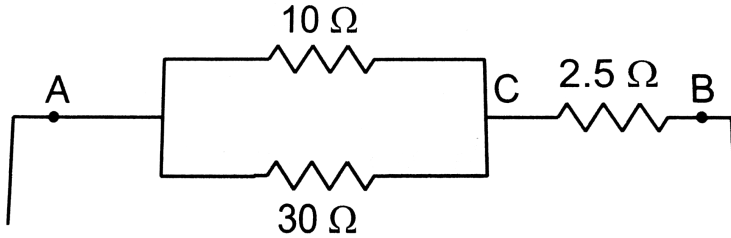

 [Watch Video Solution](#)

7. Find the value of R in figure so that there is no current in the 50(Ω) resistor.

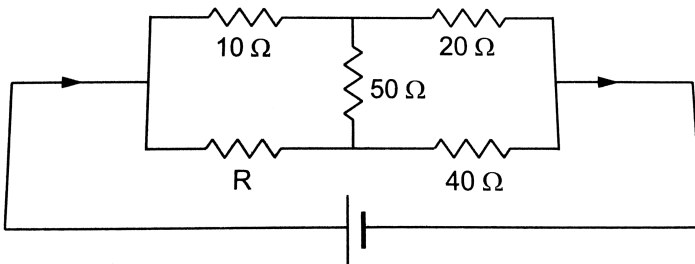

A. 20

B. 30

C. 40

D. 50

Answer: A



[Watch Video Solution](#)

8. The ammeter shown in figure consists of a $480(\omega)$ coil connected in parallel to a $20(\omega)$ shunt. Find the reading of

the ammeter.

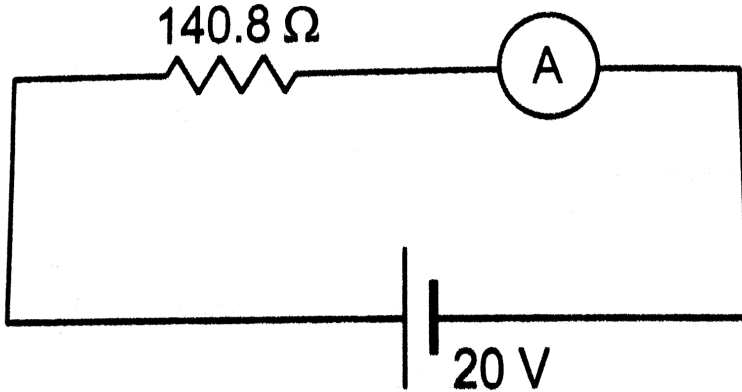

[Watch Video Solution](#)

9. A capacitor of capacitance $100(\mu)F$ is charged by connecting it to a battery of emf 12 V and internal resistance $2(\Omega)$. (a) Find the time constant of the circuit. (b) Find the time taken before 99% of maximum charge is stored on the capacitor.

[Watch Video Solution](#)

10. The plates of a $50(\mu)F$ capacitor charged to $400(\mu)C$ are connected through a resistance of $1.0k(ohm)$. Find the charge remaining on the capacitor 1s after the connection is made.

 [Watch Video Solution](#)

Worked Out Examples

1. An electron moves in a circle of radius 10cm with a constant speed of $4.0 \times 10^6 ms^{-1}$. Find the electric current at a point on the circle.

 [Watch Video Solution](#)

2. A current 4.0 A exist in a wire of cross-sectional area 2.0mm^2 . If each cubic metre of the wire contains 12.0×10^{28} free electrons, then the drift speed is

 [Watch Video Solution](#)

3. Find the resistance of a copper coil of total wire-length 10m and area of cross section 1.0mm^2 . What would be the resistance of a similar coil of aluminium? The resistivity of copper = $1.7 \times 10^{-8}(\Omega)\text{m}$ and that of aluminium $2.6 \times 10^{-8}(\Omega)$.

 [Watch Video Solution](#)

4. A parallel-plate capacitor has plates of area 10cm^2 separated by a distance of 1mm. It is filled with the dielectric mica and connected to a battery of emf 6 volts. Find the leakage current through the capacitor. Resistivity of mica = $1 \times 10^{13}(\Omega)m$.

 [Watch Video Solution](#)

5. Find the resistance of a hollow cylindrical conductor of length 1.0m and inner and outer radii 1.0mm and 2.0mm respectively. The resistivity of the material is $2.0 \times 10^{-8}(\Omega)m$.

 [Watch Video Solution](#)

6. A battery of emf 2V and internal resistance $0.5(\Omega)$ is connected across a resistance of $9.5(\Omega)$, how many electrons cross through a cross section of the resistance in 1 second?



[Watch Video Solution](#)

7. A cell of e.m.f. 2V and internal resistance 0.1Ω is being charged by a current of 5A. Calculate the potential difference between the terminals of the cells.



[Watch Video Solution](#)

8. Shown n batteries connected to form a circuit. The resistances denote the internal resistances of the batteries which are related to the emf's as $r_i = k(\varepsilon)_i$ where K is a constant. The solid dots represent the terminals of the batteries. Find (a) the current through the circuit and (b) the potential difference between the terminals of the i th battery.

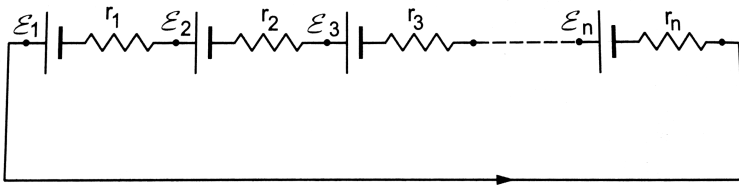

[Watch Video Solution](#)

9. A copper rod of length 20cm and cross-sectional area $2mm^2$ is joined with a similar aluminium rod as shown in

figure .Find the resistance of the combination between the ends, Resistivity of copper = $1.7 \times 10^{-8}(\Omega)m$ and that of aluminium = $2.6 \times 10^{-8}(\Omega)m$.

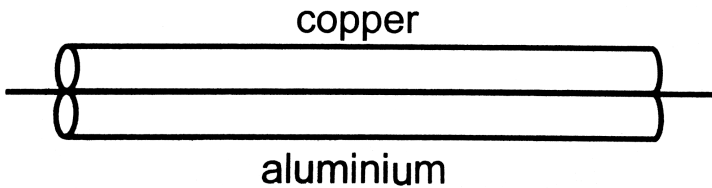

[▶ Watch Video Solution](#)

10. A wire of resistance $10(\Omega)$ is bent to form a complete circle. Find its resistance between two diametrically

opposite points.

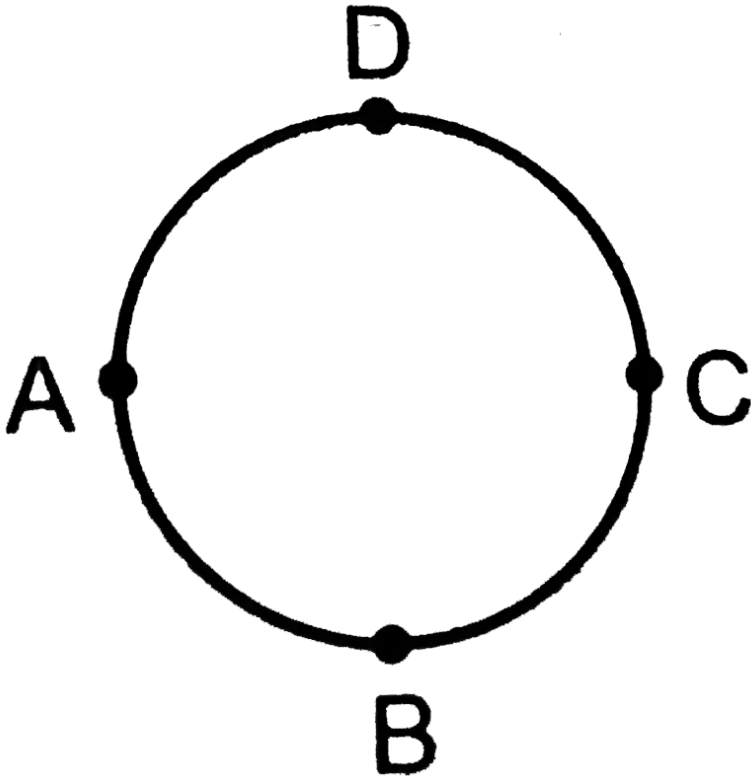

A. 1.5

B. 2.5

C. 3.5

D. 4.5

Answer: B

 [Watch Video Solution](#)

11. find the currents in the different resistor shown in figure.

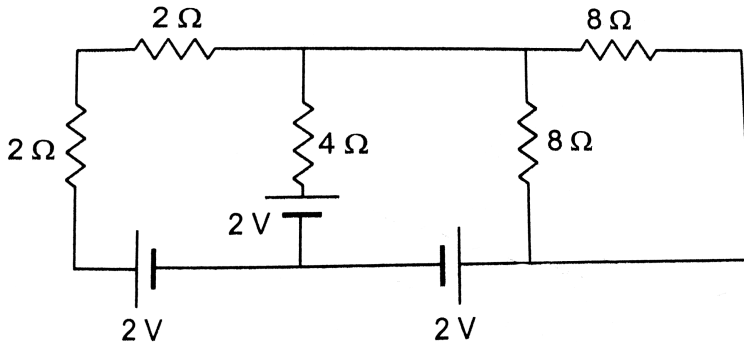

 [Watch Video Solution](#)

12. Find the current supplied by the battery in the circuit shown in figure.

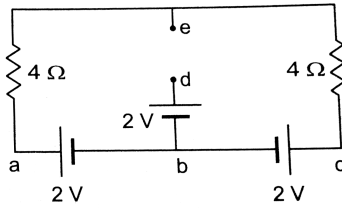
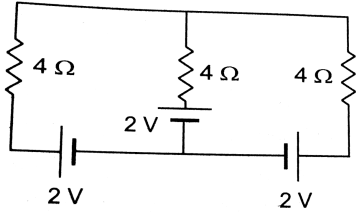

 [Watch Video Solution](#)

13. Find the equivalent resistance between the point a and b of the network shown in figure.

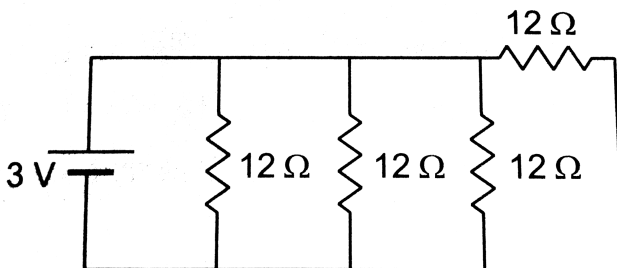

A. 3

B. 2

C. 1

D. 5

Answer: A

 [Watch Video Solution](#)

14. Find the effective resistance between the points A and B in figure.

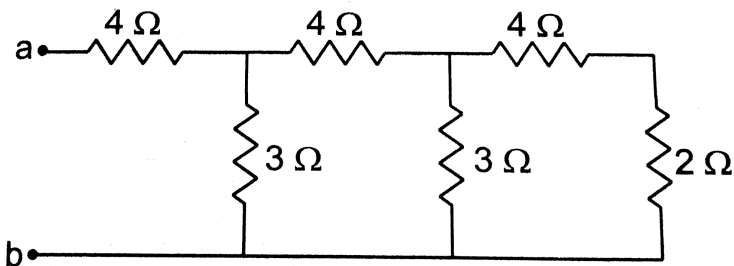



Watch Video Solution

15. Find the equivalent resistance of the network shown in figure between the points a and b

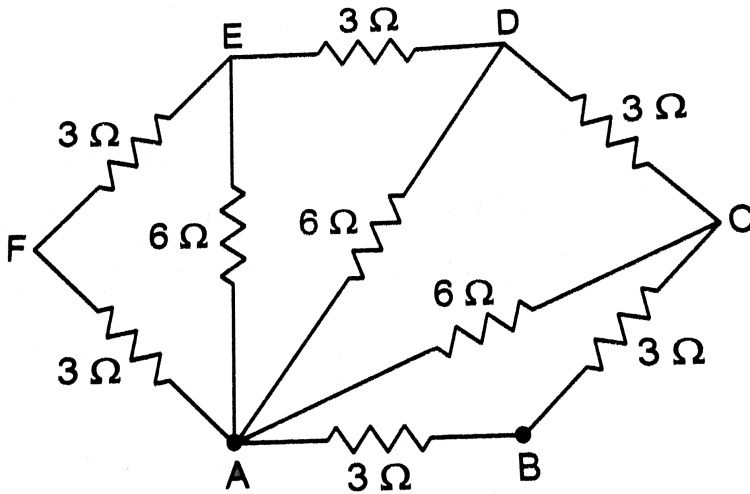

Watch Video Solution

16. Each resistor shown in figure has a resistance of $10(\Omega)$ and the battery has an emf of 6 V. Find the current supplied by the battery .

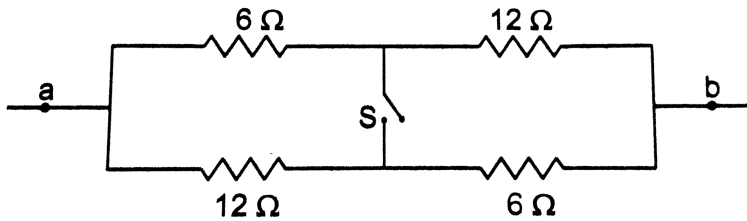

 [View Text Solution](#)

17. Find the equivalent resistances of the network shown in figure between the points A and B.

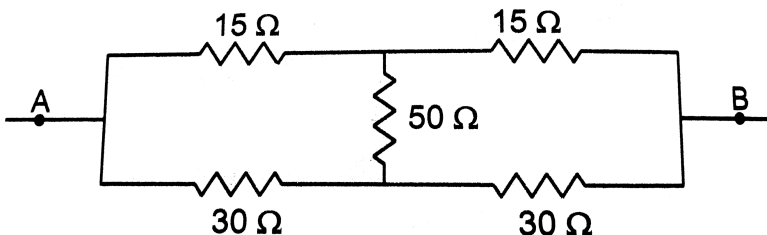

18. In the circuit shown in figure E, F, G and H are cell of emf 2,1,3, and 1V respectively. The resistances 2,1,3 and 1(Ω) are their respective internal resistance. Calculate (a) the potential difference between B and D and (b) the potential differences across the terminals of each of each of the cells G and H.

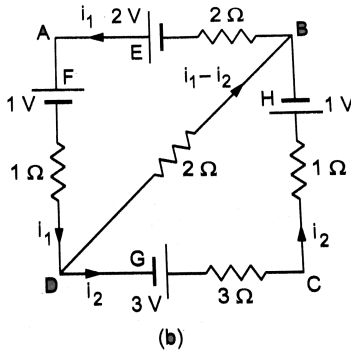
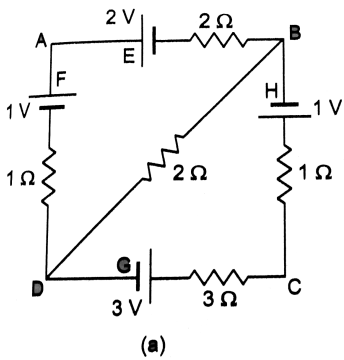

A. $\frac{21}{12} V$.

B. $\frac{2}{13} V$.

C. $\frac{21}{14} V$.

D. $\frac{21}{13} V$.

Answer: D

 [Watch Video Solution](#)

19. Find the equivalent resistance between the point a and b of the circuit shown in figure

 [View Text Solution](#)

20. Find the currents going through the three resistors ' R_1 , R_2 and R_3 ' in the circuit of figure.

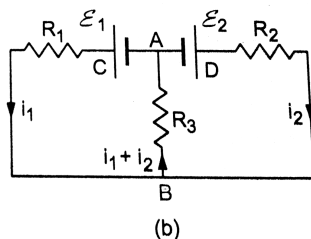
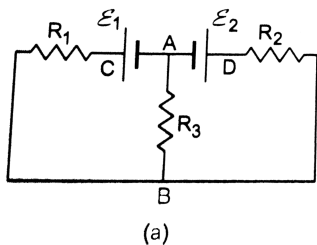

[▶ Watch Video Solution](#)

21. Twelve wire, each having resistance r , are joined to form a cube as shown in figure. Find the equivalent resistance

between the end of a face diagonal such as a and c .

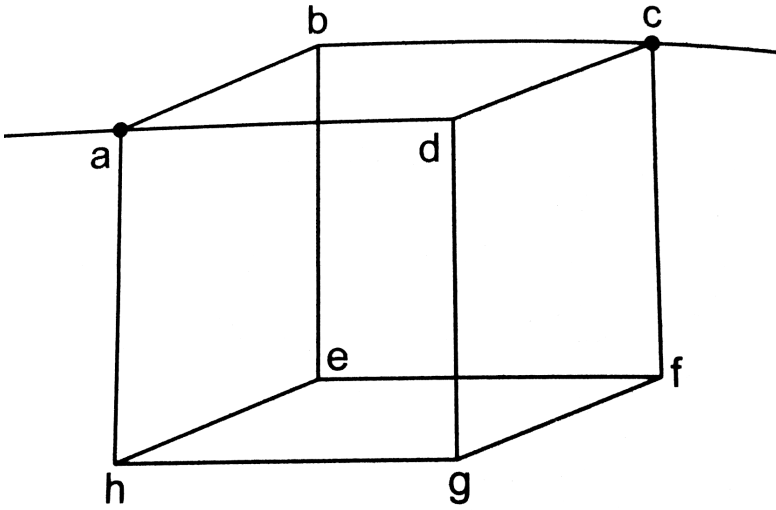

 [Watch Video Solution](#)

22. Find the equivalent resistance of the circuit of the between the ends of an edge such as a and b in figure.

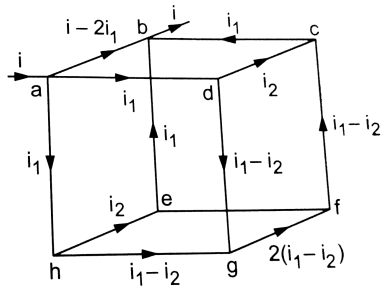
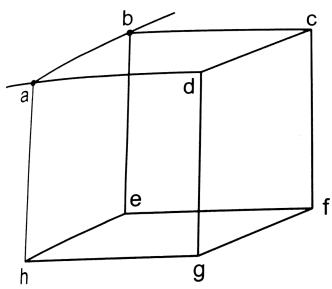

Watch Video Solution

23. Find the equivalent resistance between the points a and b of the infinite ladder shown in figure.

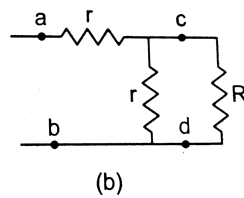
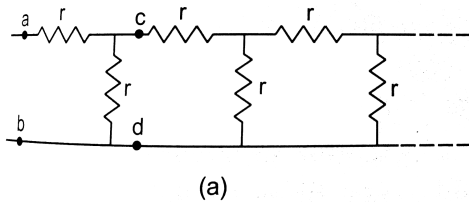

Watch Video Solution

24. Find the equivalent resistance of the network shown in figure between the points a and b .

 [Watch Video Solution](#)

25. (a) Find the current I supplied by the battery in the network shown in figure in steady state. (b) Find the charge on the capacitor.

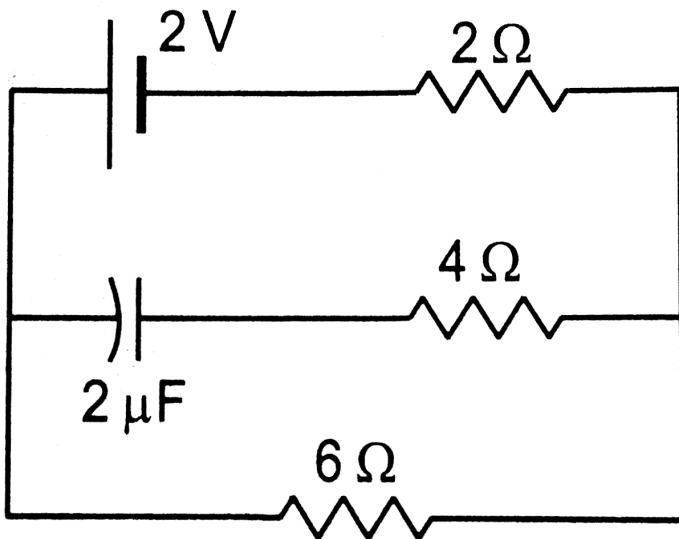



Watch Video Solution

26. A part of a circuit in steady state along with the currents flowing in the branches, the values of resistances, etc, is shown in figure. Calculate the energy stored in the capacitor.

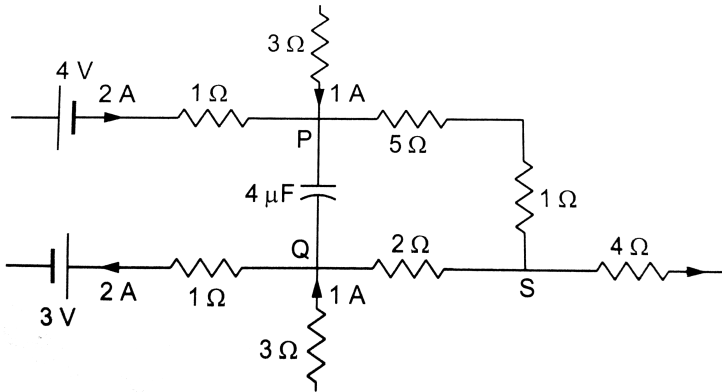

Watch Video Solution

27. (a) find the potential drops across the two resistors shown in figure. (b) A voltmeter of resistance (600Ω) is used to measure the potential drop across the (300Ω) resistor. What will be the measured potential drop?

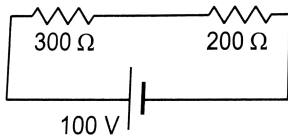

(a)

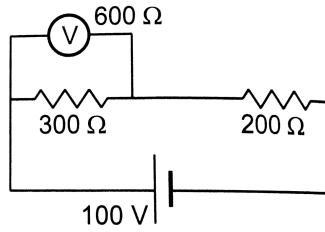

(b)

 [Watch Video Solution](#)

28. A galvanometer has a coil of resistance $100(\Omega)$ showing a full-scale deflection at $50(\mu)A$. What resistance should be added to use it as (a) a voltmeter of range 50 V (b) an ammeter of range 10 mA?



[Watch Video Solution](#)

29. The electric field between the plates of a parallel-plate capacitor of capacitance $2.0(\mu)F$ drops to one third of its initial value in $(4.4\mu)s$ when the plates are connected by a thin wire. Find the resistance of the wire.



[Watch Video Solution](#)

30. A capacitor is connected to a 12 V battery through a resistance of (10Ω) . It is found that the potential difference across the capacitor rises to 4.0 V in $1(\mu)s$. Find the capacitance of the capacitor.



[Watch Video Solution](#)

31. A capacitor charged to $50V$ is discharged by connecting the two plates at $t = 0$. If the potential difference across the plates drops to $1.0 V$ at $t=10$ ms, what will be the potential difference at $t=20$ ms?

 [Watch Video Solution](#)

32. A $5.0(\mu)F$ capacitor having a charge of $(20(\mu)C)$ is discharged through a wire of resistance (5.0Ω) . Find the heat dissipated in the wire between 25 to 50 (μ)s after the connections are made.

 [Watch Video Solution](#)

Worked Out Example

1. Find the equivalent resistances between the points a and c of the network shown in figure. Each resistance is equal to r .

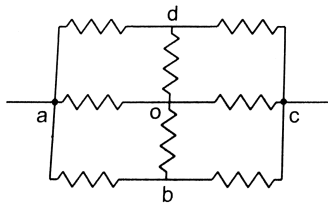

(a)

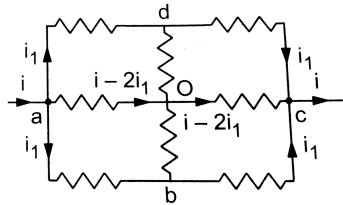

(b)

 [Watch Video Solution](#)

Short Answer

1. Suppose you have three resistor each of value (30Ω).List all the different resistances you can obtain using them.



[Watch Video Solution](#)

2. A proton beam is going from east to west. Is there an electric current ? If yes, in what direction?



[Watch Video Solution](#)

3. In an electrolyte, the positive ions move from left to right and the negative ions from right to left. Is there a net current? If yes, in what direction?



[Watch Video Solution](#)

4. In a TV tube, the electrons are accelerated from the rear to the front. What is the direction of the current?

 [Watch Video Solution](#)

5. The drift speed is defined as $v_d = (\Delta l / \Delta t)$ where (Δl) is the distance drifted in a long time (Δt) . Why don't we define the drift speed as the limit of $(\Delta l / \Delta t)$ as $(\Delta t \rightarrow 0)$?

 [Watch Video Solution](#)

6. One of your friends argues that he has read in previous chapters that there can be no electric field inside a conductor. And hence there can be no current through it. What is the fallacy in this argument?



[Watch Video Solution](#)

7. When a current is established in a wire, the free electrons drift in the direction opposite to the current, Does the number of free electrons in the wire continuously decrease?



[Watch Video Solution](#)

8. A fan with copper winding in its motor consumes less power as compared to an otherwise similar fan having aluminium winding. Explain.

 [Watch Video Solution](#)

9. The thermal energy developed in a current-carrying resistor is given by $U = i^2 R t$ and also by $U = V i t$. Should we say that U is proportional to i^2 or to i ?

 [Watch Video Solution](#)

10. Do "work done by the battery" and "the thermal energy developed" represent two names of the same physical

quantity?



[Watch Video Solution](#)

11. Is work done by a battery always equal to the thermal energy developed in electrical circuits? What happens if a capacitor is connected in the circuit?



[Watch Video Solution](#)

12. A nonideal battery is connected to a resistor. Is work done by the battery equal to the thermal energy developed in the resistor? Does your answer change if the battery is ideal?



[Watch Video Solution](#)

13. Sometimes it is said that "heat is developed" in a resistance when there is an electric current in it .Recall that heat is defined as the energy being transferred due to the temperature difference, Is the statement under quotes technically correct?

 [Watch Video Solution](#)

14. we often say "a current is going through the wire "
What goes through the wire,the charge or the current ?

 [Watch Video Solution](#)

15. Would you prefer a voltmeter or a potentiometer to measure the emf of a battery?



[Watch Video Solution](#)

16. Does a conductor become charged when a current is passed through it?



[Watch Video Solution](#)

17. Can the potential difference across a battery be greater than its emf?



[Watch Video Solution](#)

Objective 1

1. A metallic resistor is connected across a battery. If the number of collisions of the free electrons with the lattice is somehow decreased in the resistor (for example, by cooling it), the current will

- A. (a) increase
- B. (b) decrease
- C. (c) remain constant
- D. (d) become zero

Answer: A



Watch Video Solution

2. Two resistors A and B have resistances R_A and R_B respectively with $R_A < R_B$. The resistivities of their materials are (ρ_A) and (ρ_B) .

A. (a) $(\rho_A) > (\rho_B)$

B. (b) $(\rho_A) = (\rho_B)$

C. (c) $(\rho_A) < (\rho_B)$

D. (d) the information is not sufficient to find the relation between (ρ_A) and (ρ_B)

Answer: D



Watch Video Solution

3. The product of resistivity and conductivity of a cylindrical conductor depends on

- A. (a) temperature
- B. (b) material
- C. (c) area of cross section
- D. (d) none of these

Answer: D



[Watch Video Solution](#)

4. As the temperature of a metallic resistor is increased, the product of resistivity and conductivity:-

A. (a)increase

B. (b)decrease

C. (c) remains constant

D. (d) may increase or decrease.

Answer: C



Watch Video Solution

5. In an electric circuit containing a battery,the charge (assumed positive)inside the battery.

A. (a) always goes from the positive terminal to the
negative terminal

B. (b) may go from the positive terminal to the negative terminal

C. (c) always goes from the negative terminal to the positive terminal

D. (d) does not move

Answer: B



[Watch Video Solution](#)

6. A resistor of resistance R is connected to an ideal battery. If the value of R is decreased, the power dissipated in the resistor will

A. (a) increase

B. (b) decrease

C. (c) remain unchanged.

D.

Answer: A

 [Watch Video Solution](#)

7. A current passes through a resistor. Let K_1 and K_2 represent the average kinetic energy of the conduction electrons and the metal ions respectively.

A. (a) $K_1 < K_2$

B. (b) $K_1 = K_2$

C. (c) $K_1 > K_2$

D. (d) any of these three may occur.

Answer: C



Watch Video Solution

8. two resistors R and $2R$ are connected in series in an electric circuit. The thermal energy developed in R and $2R$ are in the ratio

A. (a) 1:2

B. (b) 2:1

C. (c) 1:4

D. (d) 4:1

Answer: A



Watch Video Solution

9. Two resistances R and $2R$ are connected in parallel in an electric circuit. The thermal energy developed in R and $2R$ are in the ratio

A. (a) 1:2

B. (b) 2:1

C. (c) 1:4

D. (d) 4:1

Answer: B



Watch Video Solution

10. A uniform wire of resistance (50Ω) is cut into 5 equal parts. These parts are now connected in parallel. The equivalent resistance of the combination is

- A. (a) (2Ω)
- B. (b) (10Ω)
- C. (c) (250Ω)
- D. (d) (6250Ω)

Answer: A



Watch Video Solution

11. Consider the following two statements:

(A) Kirchhoff's junction law follows from conservation of charge.

(B) Kirchhoff's loop law follows from conservative nature of electric field .

A. (a) Both A and B are correct

B. (b) A is correct but B is wrong

C. (c) B is correct but A is wrong

D. (d) Both A and B are wrong

Answer: A



Watch Video Solution

12. the nonideal batteries are connected in series. Consider the following statements :

(A) The equivalent emf is larger than either of the two emfs.

(B) the equivalent internal resistance is smaller than either of the two internal resistances.

A. (Each of A and B is correct.

B. (b) A is correct but B is wrong

C. (c) B is correct but A is wrong

D. (d) each of A and B are wrong

Answer: B



Watch Video Solution

13. Two nonideal batteries are connected in parallel.

Consider the following statements:

(A) The equivalent emf is smaller than either of the two emfs.

(B) The equivalent internal resistance is smaller than either of the two internal resistances.

A. (a) Both A and B are correct

B. (b) A is correct but B is wrong

C. (c) B is correct but A is wrong

D. (d) Both A and B are wrong

Answer: C



Watch Video Solution

14. The net resistance of an ammeter should be small to ensure that

A. (a) it does not get overheated

B. (b) it does not draw excessive current

C. (c) it can measure large currents

D. (d) it does not appreciably change the current to be measured.

Answer: D



Watch Video Solution

15. The net resistance of a voltmeter should be large to ensure that

- A. (a) it does not get overheated
- B. (b) it does not draw excessive current
- C. (c) it can measure large potential differences
- D. (d) it does not appreciably change the potential difference to be measured.

Answer: D



Watch Video Solution

16. Consider a capacitor-charging circuit. Let Q_1 be the charge given to the capacitor in a time interval of 10ms and Q_2 be the charge given in the next time interval of 10ms. Let $10\mu C$ charge be deposited in a time interval t_1 and the next ($10\mu C$) charge is deposited in the next time interval t_2 .

A. (a) $Q_1 > Q_2, t_1 > t_2$.

B. (b) $Q_1 > Q_2, t_1 < t_2$.

C. (c) $Q_1 < Q_2, t_1 > t_2$.

D. (d) $Q_1 < Q_2, t_1 < t_2$.

Answer: B



Watch Video Solution

Objective 2

1. Electrons are emitted by a hot filament and are accelerated by an electric field as shown in figure .The two stops at the left ensure that the electron beam has a uniform cross-section.

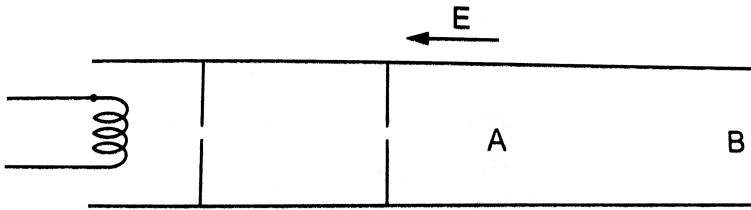

- A. (a)The speed of the electron is more at B than at A.
- B. (b)The electric current is from left to right.
- C. (c)The magnitude of the current is larger at B than at A .

D. (d)The current density is more at B than at A.

Answer: A

 [Watch Video Solution](#)

2. A capacitor with no dielectric is connected to a battery at $t=0$. Consider a point A in the connecting wires and a point B in between the plates.

A. (a)There is no current through A.

B. (b)There is no current through B.

C. (c)There is a current through A as long as the charging is not complete.

D. (d) There is a current through B as long as the charging is not complete.

Answer: B::C

 [Watch Video Solution](#)

3. When no current, is passed through a conductor:-

A. (a) the free electrons do not move

B. (b) the average speed of a free electron over a large period of time is zero

C. (c) the average velocity of a free electron over a large period of time is zero

D. (d) The average of the velocities of all the free electrons at an instant is zero.

Answer: C::D

 [Watch Video Solution](#)

4. Which of the following quantities do not change when a resistor connected to a battery is heated due to the current?

A. (a) Drift speed

B. (b) Resistivity

C. (c) Resistance

D. (d) Number of free electrons

Answer: D

 [Watch Video Solution](#)

5. When the temperature of a conductor increase the ratio of its resistivity and conductivity

A. (a)increase

B. (b)decrease

C. (c)remain constant

D. (d)may increase or decrease depending on the actual temperature.

Answer: A

 [Watch Video Solution](#)

6. A current passes through a wire of nonuniform cross-section. Which of the following quantities are independent of the cross section?

- A. (a) The charge crossing in a given time interval
- B. (b) Drift speed
- C. (c) Current density
- D. (d) Free-electron density

Answer: A::D

7. Mark out the correct options

- A. (a) An ammeter should have small resistance
- B. (b) An ammeter should have large resistance.
- C. (c) A voltmeter should have small resistance
- D. (d) A voltmeter should have large resistance

Answer: A::D



Watch Video Solution

8. A capacitor of capacitance $500\mu F$ is connected to a battery through a $10k\Omega$ resistor. The charge stored on the

capacitor in the first 5 sec is larger than the charge stored in the next

A. (a) 5 s

B. (b) 50 s

C. (c) 500 s

D. (d) 500 s

Answer: A::B::C::D

 [Watch Video Solution](#)

9. A capacitor C_1 of capacitance $1\mu F$ and a capacitor C_2 of capacitance $2\mu F$ are separately charged by a common battery for a long time. The two capacitors are then

separately discharged through equal resistors. Both the discharge circuits are connected at $t = 0$.

A. The current in each of the two discharging circuits is zero at $t = 0$

B. The currents in the two discharging circuits at $t = 0$ are equal but not zero

C. The currents in the two discharging circuits at $t = 0$ are unequal.

D. C_1 loses 50% of its initial charge sooner than C_2 loses 50% of its initial charge.

Answer: B::D



Watch Video Solution

Exercises

1. The amount of charge passed in time t through a cross-section of a wire is

$$Q(t) = At^2 + Bt + C.$$

(a) Write the dimensional formulae for A, B and C .

(b) If the numerical values of $A, B,$ and C are $5, 3$ and 1 respectively in SI units, find the value of the current at $t=5$ s.

 [Watch Video Solution](#)

2. An electric gun emits 2.0×10^{16} electrons per second.

What electric current does this correspond to ?

 [Watch Video Solution](#)

3. The electric current existing in a discharge tube is $2.0(\mu)A$. How much charge is transferred across a cross-section of the tube in 5 minutes ?

 [Watch Video Solution](#)

4. The current through a wire varies with time as $I = I_0 + \alpha t$, where $I_0 = 10 \text{ A}$ and $\alpha = 4As^{-1}$. The charge that flows across a cross-section of the wire in first 10 seconds is

 [Watch Video Solution](#)

5. A current of 1.0 A exists in a copper wire of cross-section 1.0mm^2 . Assuming one free electron per atom calculate the drift speed of the free electrons in the wire. The density of copper is 9000kgm^{-3} .



[Watch Video Solution](#)

6. A wire of length 1 m and radius 0.1mm has a resistance of $100(\Omega)$. Find the resistivity of the material .



[Watch Video Solution](#)

7. A uniform wire resistance $100(\Omega)$ is melted and recast in a wire of length double that of the original . What would

be the resistance of the wire?

 [Watch Video Solution](#)

8. Consider a wire of length 4m and cross-sectional area 1mm^2 carrying of 2A. If each cubic metre of the material contains 10^{29} free electrons, find the average time taken by an electron to cross the length of the wire.

 [Watch Video Solution](#)

9. What length of a copper wire of cross-sectional area 0.01mm^2 will be needed to prepare a resistance of $1\text{k}\Omega$?
Resistivity of copper = $1.7 \times 10^{-8}\Omega\text{m}$.

 [Watch Video Solution](#)

10. Figure shows a conductor of length l carrying current i and having a circular cross-section. The radius of cross section varies linearly from a to b . assuming that $(b - a) \ll l$ calculate current density at distance x from left end.

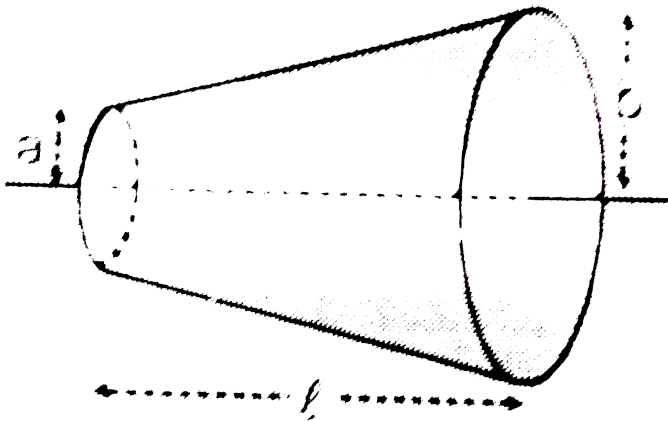

[▶ Watch Video Solution](#)

11. A copper wire of *radius* 0.1mm and resistance $1\text{k}(\Omega)$ is connected across a power supply of 20 V . (a) How many electrons are transferred per second between the supply and the wire at one end? (b) Write down the current density in the wire.



[Watch Video Solution](#)

12. Calculate the electric field in a copper wire of cross-sectional area 2.0mm^2 carrying a current of 1A . The resistivity of copper $= 1.7 \times 10^{-8}(\Omega)\text{m}$.



[Watch Video Solution](#)

13. A wire has a length of 2.0m and a resistance of $5.0(\Omega)$. Find the electric field existing inside the wire if it carries a current of 10A.

 [Watch Video Solution](#)

14. The resistances of an iron wire and a copper wire at $20^\circ C$ are $3.9(\Omega)$ and $4.1(\Omega)$ respectively. At what temperature will the resistances be equal? Temperature coefficient of resistivity for iron is $5.0 \times 10^{-3} K^{-1}$ and for copper it is $4.0 \times 10^{-3} K^{-1}$. Neglect any thermal expansion.

 [Watch Video Solution](#)

15. The current in a conductor and the potential difference across its ends are measured by an ammeter and a voltmeter. The meters draw negligible current. The ammeter is accurate but the voltmeter has a zero error (that is, it does not read zero when no potential difference is applied). Calculate the zero error if the readings for two different conditions are 1.75A, 14.4V and 2.75A, 22.4V.

 [Watch Video Solution](#)

16. Show an arrangement to measure the emf (ϵ) and internal resistance r of a battery. The voltmeter has a very high resistance and the ammeter also has some resistance. The voltmeter reads 1.52 V when the switch S is open. When the switch is closed the voltmeter reading

drops to 1.45 V and the ammeter read 1.0A Find the emf and the internal resistance of the battery.

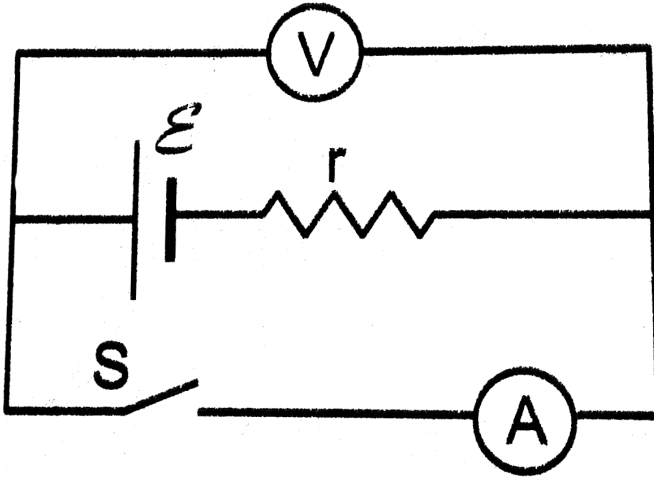

[▶ Watch Video Solution](#)

17. The potential difference between the terminals of a battery of emf 6.0V and internal resistance 1(Ω) drops to 5.8 V when connected across an external resistor. Find the resistance of the external resistor.



[Watch Video Solution](#)

18. The potential difference between the terminals of a 6.0V battery is 7.2 V when it is being charged by a current of 2.0A. What is the internal resistance of the battery?



[Watch Video Solution](#)

19. The internal resistance of an accumulator battery of emf 6V is $10(\Omega)$ when it is fully discharged. As the battery gets charged up, its internal resistance decreases to $1(\Omega)$. The battery in its completely discharged state is connected to a charger which maintains a constant potential difference of 9 V. Find the current through the battery

(a) just after the connections are made and (b) after a long time when it is completely charged.

 [Watch Video Solution](#)

20. Find the value of i_1 / i_2 in figure if

(a) $R = 0.1(\Omega)$

(b) $R = 1(\Omega)$

(c) $R = 10(\Omega)$.

Note from your answers that in order to get more current from a combination of two batteries they should be joined in parallel if the external resistance is small and in series if the external resistance is large as compared to the internal

resistances.

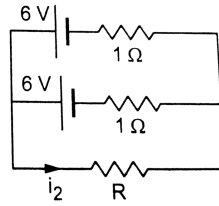
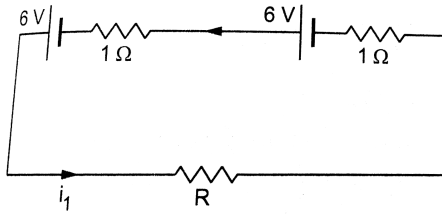

[Watch Video Solution](#)

21. Consider $N = n_1 \cdot n_2$ identical cells, each of emf (ε) and internal resistance r . Suppose n_1 cells are joined in series to form a line and n_2 such are connected in parallel. The combination drives a current in an external resistance R .

(a) find the current in the external resistance,

(b) Assuming that n_1 and n_2 can be continuously varied, find the relation between n_1 , n_2 , R and r for which the current in R is maximum.

 [Watch Video Solution](#)

22. A battery of emf 100V and a resistor of resistance $10\text{k}(\Omega)$ are joined in series. This system is used as a source to supply current to an external resistance R . If R is not greater than $100(\Omega)$, the current through it is constant up to two significant digits. Find its value. This is the basic principle of a constant-current source.

 [Watch Video Solution](#)

23. If the reading of ammeter A_1 in figure is 2.4 A , what will the ammeter A_2 and A_3 read? Neglect the resistances of

the ammeter.

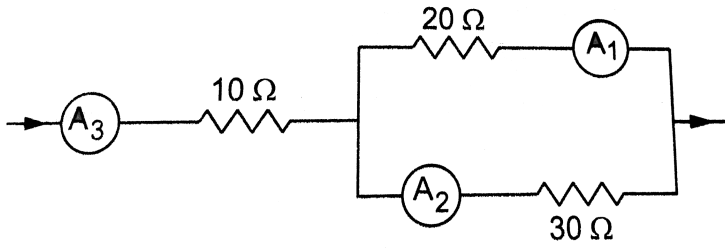

[▶ Watch Video Solution](#)

24. The resistance of the rheostat shown in figure is $30(\Omega)$. Neglecting the meter resistance, find the minimum and maximum currents through the ammeter as the rheostat is

varied.

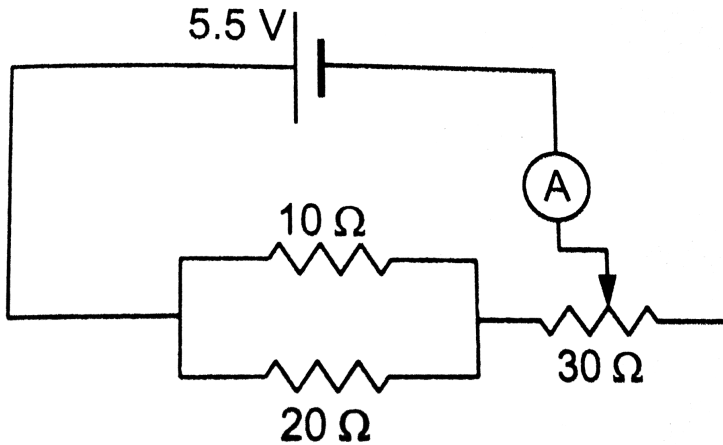

[Watch Video Solution](#)

25. Three bulbs, each having a resistance of $180(\Omega)$ are connected in parallel to an ideal battery of emf $60V$. Find the current delivered by the battery when (a) all the bulbs are switched on, (b) two of the bulbs are switched on and (c) only one bulb is switched on.

[Watch Video Solution](#)

26. Suppose you have three resistor of (20Ω) , (50Ω) and (100Ω) . what minimum and maximum resistances can you obtain from these resistors?

 [Watch Video Solution](#)

27. A bulb is made using two filaments. A switch selects whether the filaments are used individually or in parallel. When used with a 15V battery, the bulb can be operated at 5W, 10W and 15W. What should be the resistances of the filaments ?

 [Watch Video Solution](#)

28. if a current of 12mA exists in the $5\text{k}(\Omega)$ resistor, find the currents in the other three resistors. what is the potential difference between the points A and B?

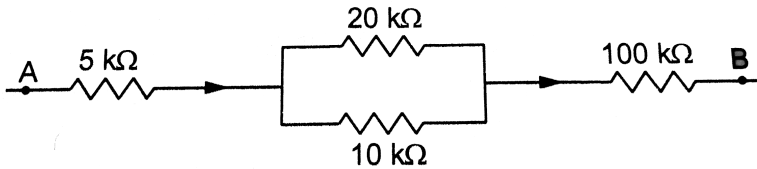

[Watch Video Solution](#)

29. An ideal battery sends a current of 5A in a resistor. When another resistor of value 10Ω is connected in parallel, the current through the battery is increased to 6A . Find the resistance of the first resistor.

[Watch Video Solution](#)

30. Find the equivalent resistances of the network shown in figure between the points a and b.

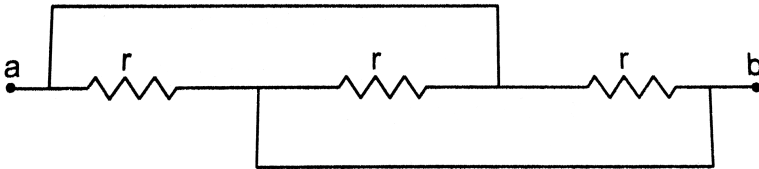

[Watch Video Solution](#)

31. A wire of resistance $15.0(\Omega)$ is bent to form a regular hexagon ABCDEFA. Find the equivalent resistance of the loop between the points (a) A and B, (b) A and C and (c) A and D.

[Watch Video Solution](#)

32. Consider the circuit shown in figure. Find the current through the $10(\Omega)$ resistor when the switch S is (a) open (b) closed .

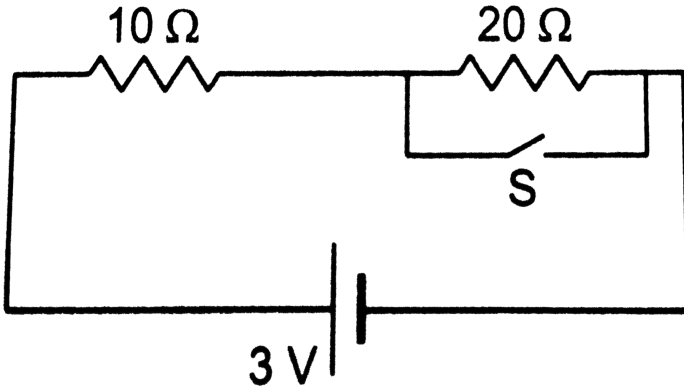

 [Watch Video Solution](#)

33. Find the currents through the three resistors shown in Figure

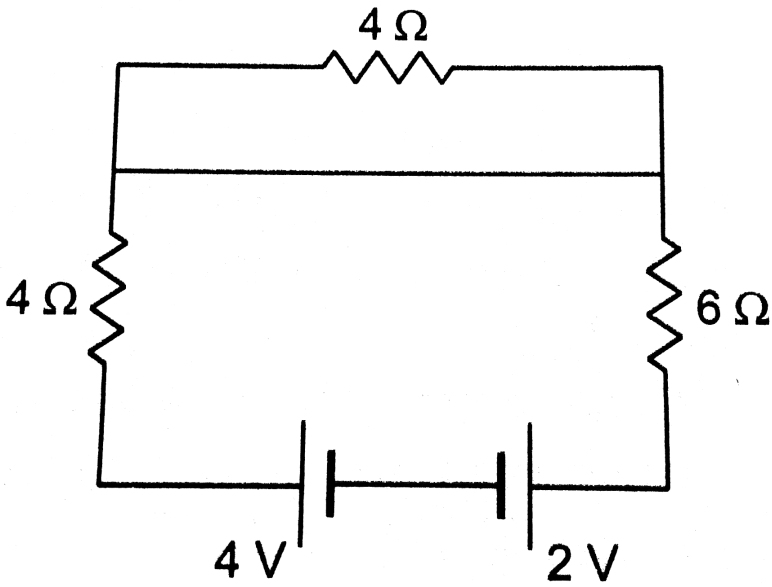

 [Watch Video Solution](#)

34. Shown a part of an electric circuit, The potentials at the points a, b, and c are 30V, 12V, and 2V respectively. Find the currents through the three resistors.

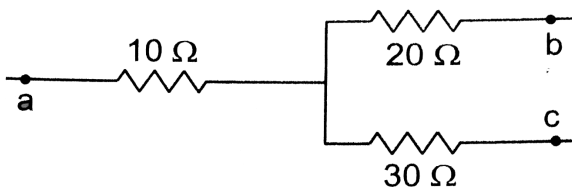



Watch Video Solution

35. Each of the resistors shown in figure has a resistance of $10(\Omega)$ and each of the batteries has an emf of $10V$. Find the currents through the resistors a and b in the two circuits.

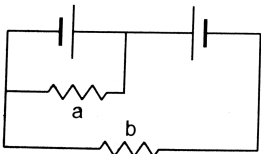

(a)

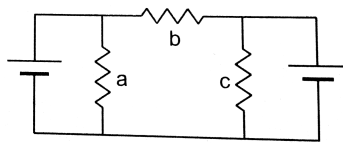

(b)



Watch Video Solution

36. Find the potential difference $V_a - V_b$ in the circuit shown in figure

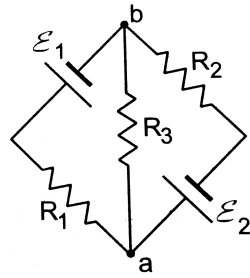
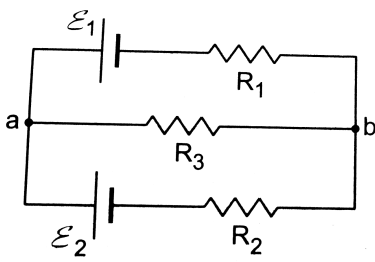

Watch Video Solution

37. In the circuit shown in figure ,
 $(\varepsilon)_1 = 3V, (\varepsilon)_2 = 2V, (\varepsilon)_3 = 1V$ and $r_1 = r_2 = r_3 = 1(\Omega)$
 .Find the potential difference between the points A and B
 and the current through each branch.

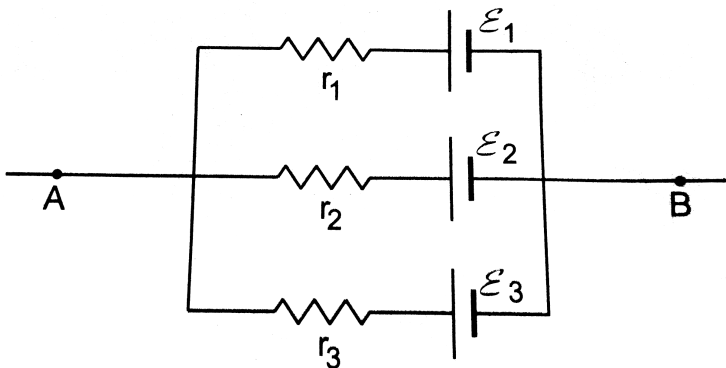

 Watch Video Solution

38. Find the current through the $10(\Omega)$ resistor shown in figure.

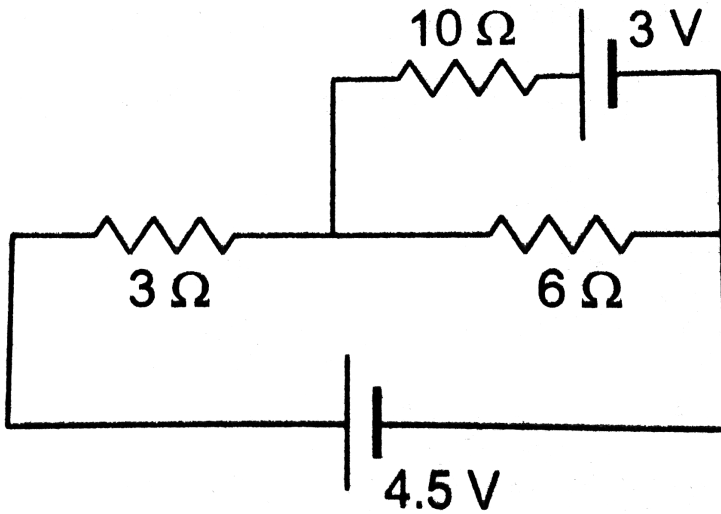

 Watch Video Solution

39. Find the current in the resistor shown in figure.

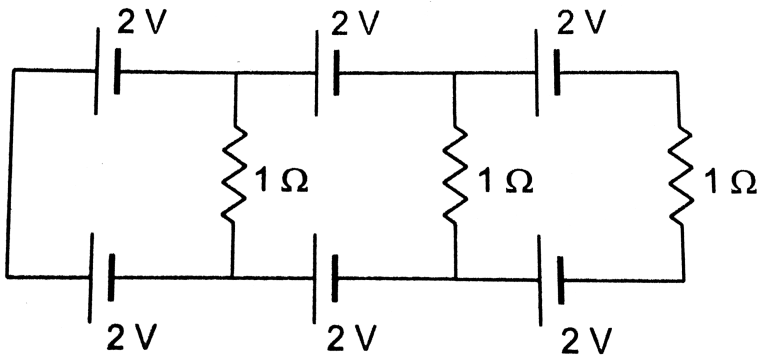

[▶ Watch Video Solution](#)

40. What should be the value of R in figure fo which the current in it is zero?

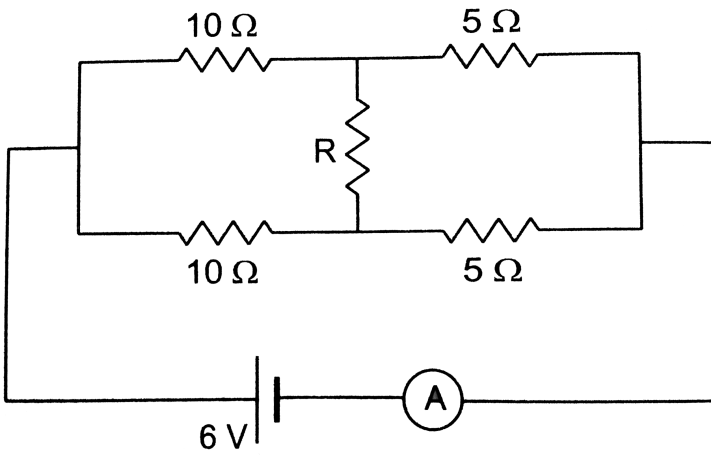

[▶ Watch Video Solution](#)

41. Find the equivalent resistance of the circuit shown in figure between the points a and b. Each resistor has a

resistances r .

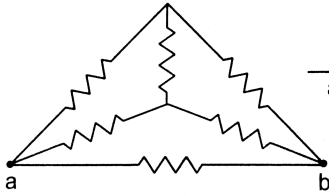

(a)

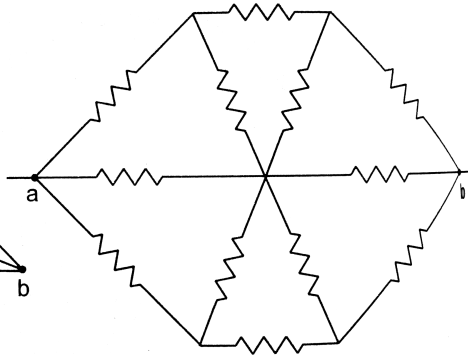

(b)



Watch Video Solution

42. Find the current measured by the ammeter in the circuit shown in figure

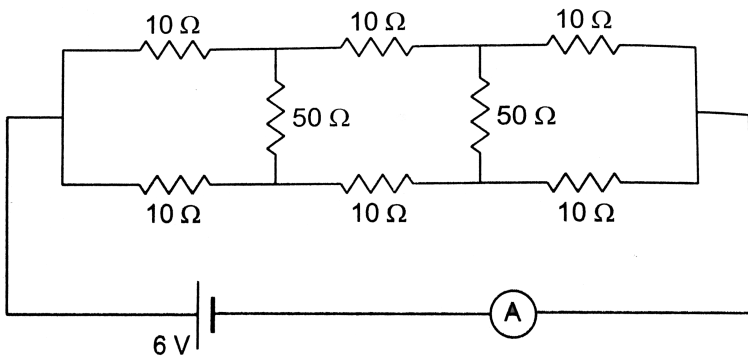

 [Watch Video Solution](#)

43. Consider the circuit shown in figure. Find (a) the current in the circuit, (b) the potential drop across the (5Ω) resistor, (c) the potential drop across the $10(\Omega)$ resistor. (d) Answer the parts (a), (b) and (c) with reference to figure.

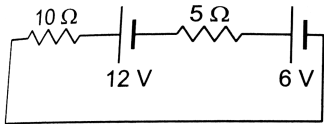

(a)

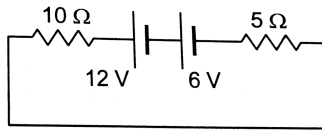

(b)

 [Watch Video Solution](#)

44. Twelve wire, each having equal resistance r , are joined to form a cube as shown in figure. Find the equivalent

resistance between the diagonally opposite points a and f .

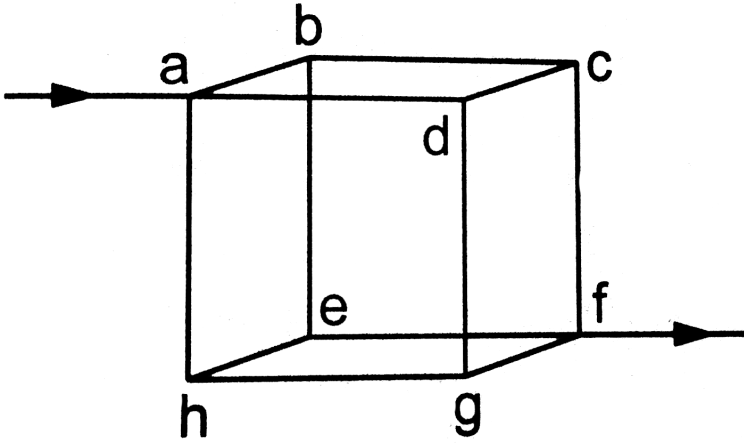

[▶ Watch Video Solution](#)

45. Find the equivalent resistances of the network shown in figure between the point a and b .

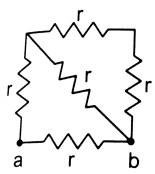

(a)

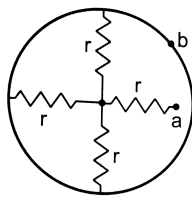

(b)

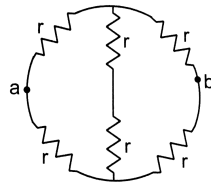

(c)

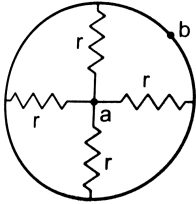

(d)

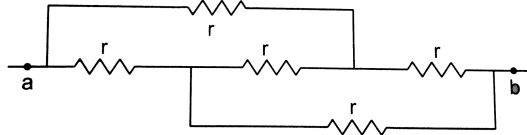

(e)

 **Watch Video Solution**

46. An infinite ladder is constructed with $1(\Omega)$ and $2(\Omega)$ resistor as shown in figure. (a) Find the effective resistance between the point A and B. (b) Find the current that passes through the (2Ω) resistor nearest to the battery.

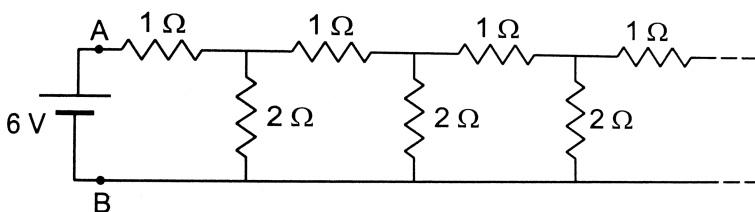

47. The emf (\mathcal{E}) and the internal resistance r of the battery shown in figure are 4.3V and $1.0(\Omega)$ respectively. The external resistance R is $50(\Omega)$. The resistances of the ammeter and voltmeter are $2.0(\Omega)$ and $200(\Omega)$ respectively. (a) Find the reading of the two meters. (b) The switch is thrown to the other side, What will be the readings of the two meters now?

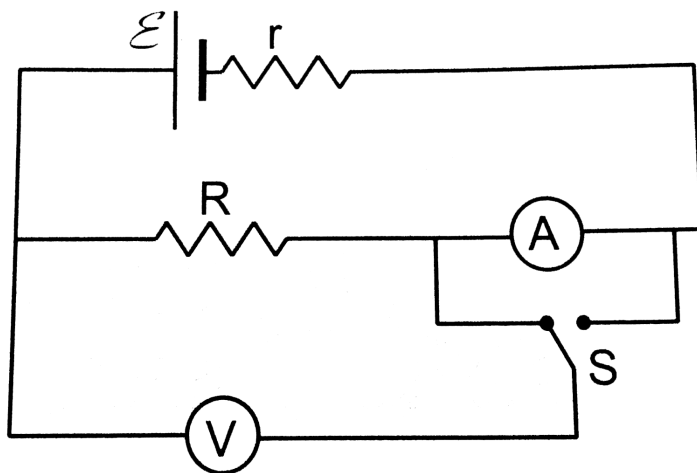



Watch Video Solution

48. A voltmeter of resistance $400(\Omega)$ is used to measure the potential difference across the $100(\Omega)$ resistor in the circuit shown in figure. (a) What will be the reading of the voltmeter? (b) What was the potential difference across $100(\Omega)$ before the voltmeter was connected?

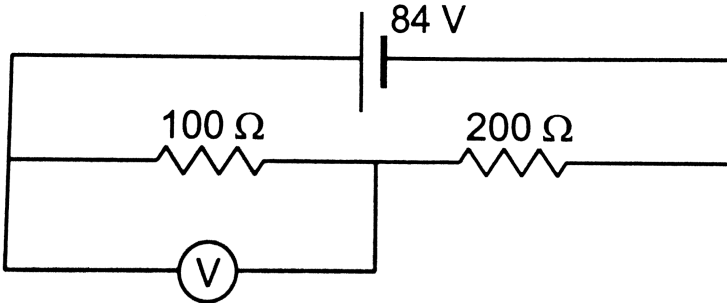

Watch Video Solution

49. The voltmeter shown in figure reads 18V across the $50(\Omega)$ resistor. Find the resistance of the voltmeter.

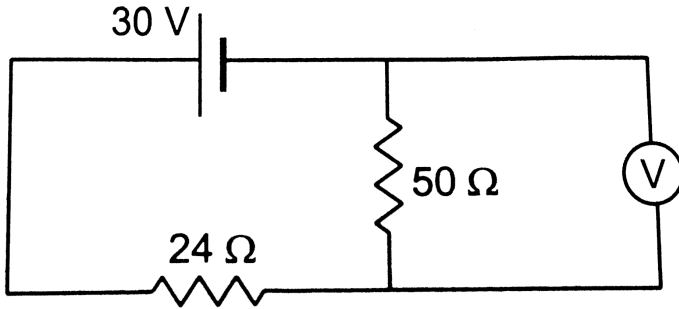

[▶ Watch Video Solution](#)

50. A voltmeter consists of a $25(\Omega)$ coil connected in series with a $575(\Omega)$ resistor. The coil takes 10mA for full scale deflection. What maximum potential difference can be measured on this voltmeter?

[▶ Watch Video Solution](#)

51. An ammeter is to be constructed which can read currents up to 2.0A. If the coil has a resistance of $25(\Omega)$ and takes 1mA for full-scale deflection, what should be the resistance of the shunt used?



[Watch Video Solution](#)

52. A voltmeter coil has resistance $50.0(\Omega)$ and a resistor of $1.15k(\Omega)$ is connected in series. It can read potential differences up to 12 volts. If this same coil is used to construct an ammeter which can measure currents up to 2.0A, what should be the resistance of the shunt used?



[Watch Video Solution](#)

53. The potentiometer wire AB shown in figure is 40 cm long. Where should the free end of the galvanometer be connected on AB so that the galvanometer may show zero deflection?

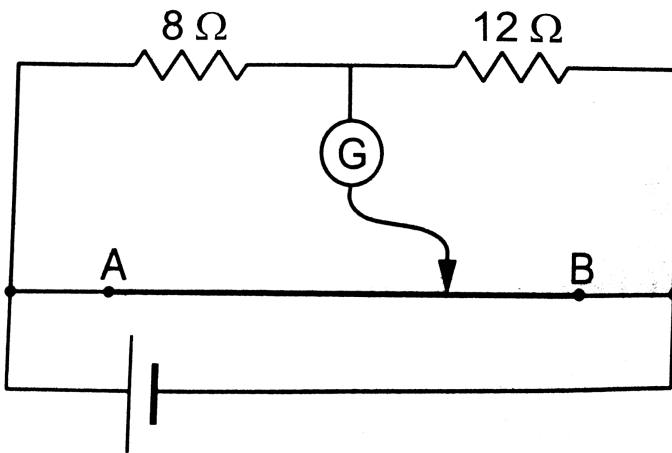

[Watch Video Solution](#)

54. The potentiometer wire AB shown in figure is 50cm long. When $AD=30\text{cm}$, no deflection occurs in the

galvanometer. Find R.

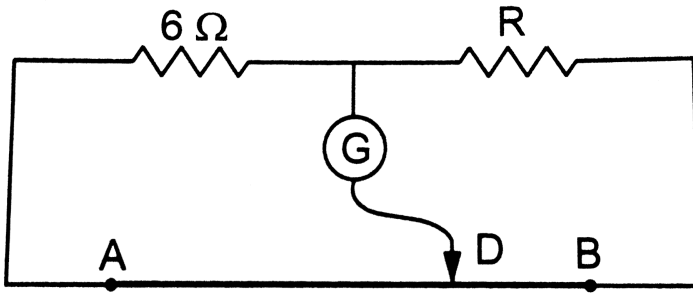

 [Watch Video Solution](#)

55. A 6-volt battery of negligible internal resistance is connected across a uniform wire AB of length 100cm. The positive terminal of another battery of emf 4V and internal resistance $1(\Omega)$ is joined to the point A as shown in figure. Take the potential at B to be zero. (a) What are the potentials at the points A and C? (b) At which point D of the wire AB, the potential is equal to the potential at C? (c) If

the point C and D are connected by a wire, what will be the current through it ? (d) If the 4V battery is replaced by 7.5V battery, what would be the answer of parts (a) and (b) ?

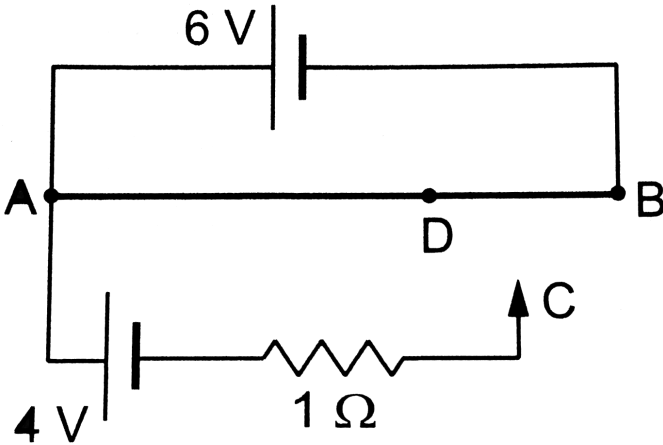

[Watch Video Solution](#)

56. Consider the potentiometer circuit arranged as in figure. The potentiometer wire is 600cm long. (a) At what distance from the point A should the jockey touch the wire

to get zero deflection in the galvanometer?(b) If the jockey touches the wire at a distance of 560cm from A, What will be the current in the galvanometer?

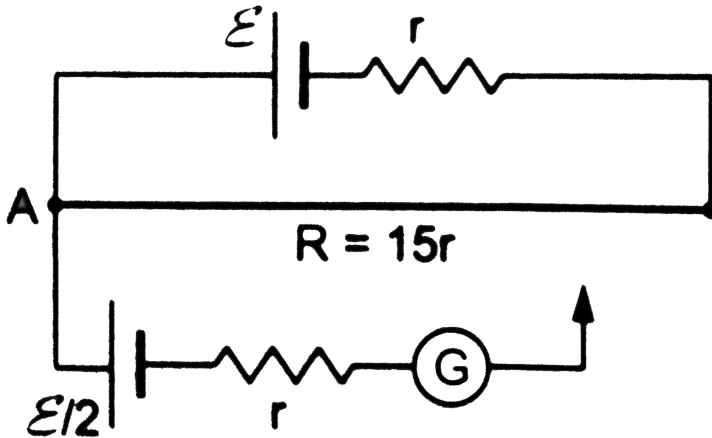

[▶ Watch Video Solution](#)

57. Find the charge on the capacitor shown in figure

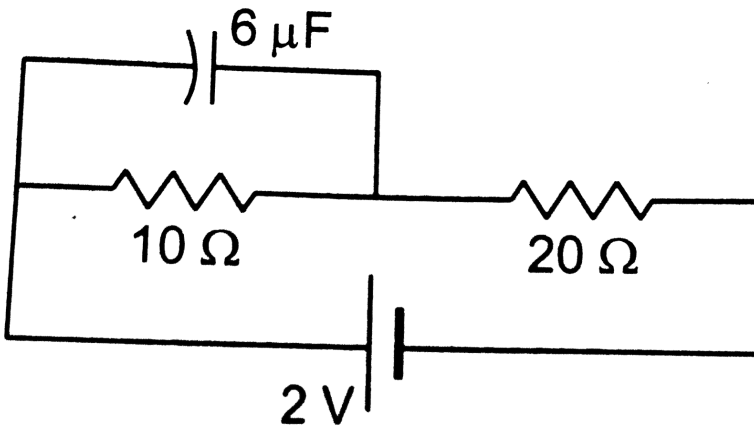

[▶ Watch Video Solution](#)

58. (a) Find the current in the $20(\Omega)$ resistor shown in figure. (b) If a capacitor of capacitance $4(\mu)\text{F}$ is joined between the point A and B, what would be the electrostatic

energy stored in it in steady state?

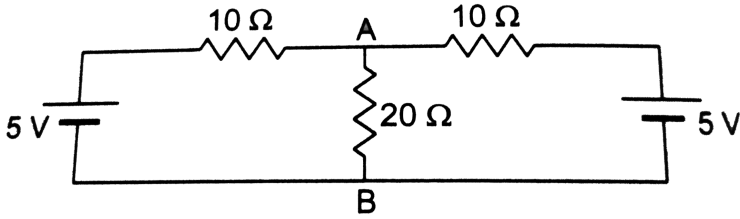

[▶ Watch Video Solution](#)

59. Find the charge on the four capacitors of capacitances $1(\mu)\text{F}$, $2(\mu)\text{F}$, $3(\mu)\text{F}$, and $4(\mu)\text{F}$, shown in figure.

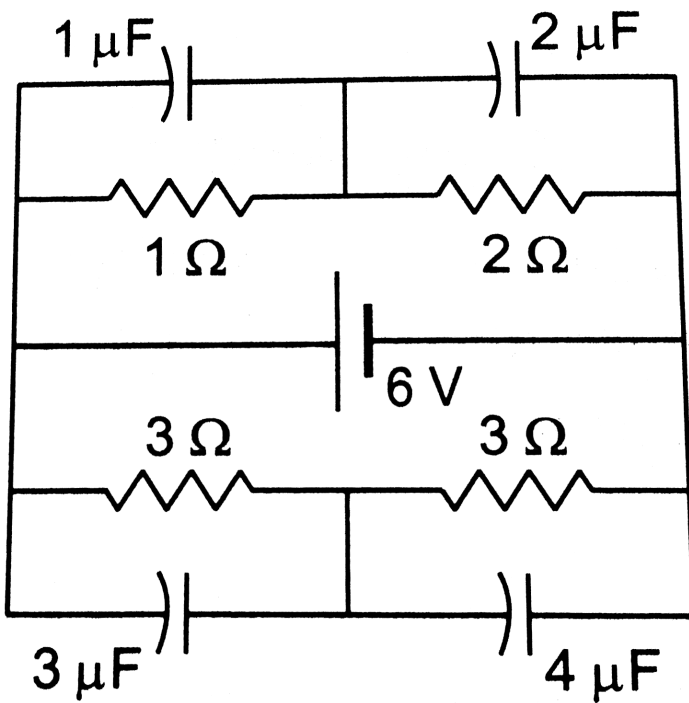

Watch Video Solution

60. find the potential difference between the point A and B and between the point B and C of figure in steady state.

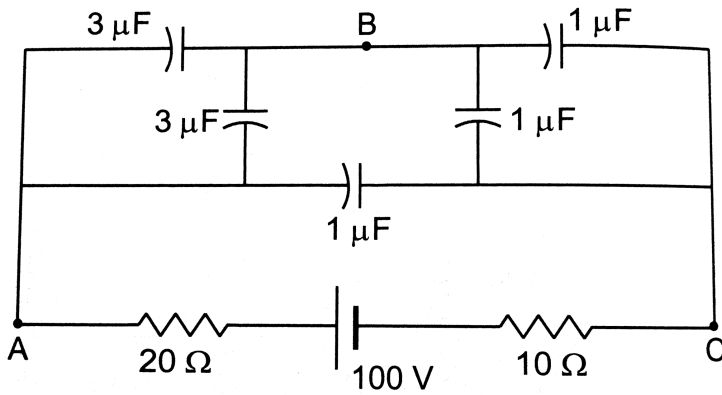

[Watch Video Solution](#)

61. A capacitance C , a resistance R and an emf (ε) are connected in series at $t=0$. What is the maximum value of (a) the potential difference across the resistor, (b) the current in the circuit, (c) the potential difference across the capacitor, (d) the energy stored in the capacitor, (e) the power delivered by the battery and (f) the power converted into heat.

[Watch Video Solution](#)

62. A parallel-plate capacitor with plate area 20cm^2 and plate separation 1.0mm is connected to a battery. The resistance of the circuit is $10\text{k}(\Omega)$. Find the time constant of the circuit.

[Watch Video Solution](#)

63. A capacitor of capacitance $10(\mu)\text{F}$ is connected to a battery of emf 2V . It is found that it takes 50ms for the charge on the capacitor to become $12.6(\mu)\text{C}$. Find the resistance of the circuit.

[Watch Video Solution](#)

64. A $20(\mu)F$ capacitor is joined to a battery of emf $6.0V$ through a resistance of $100(\Omega)$. find the charge on the capacitor $2.0ms$ after the connections are made .

 [Watch Video Solution](#)

65. The plates of a capacitor of capacitance $10(\mu)F$,charged to $60(\mu)C$,are joined together by a wire of resistance $10(\Omega)$ at $t=0$. Find the charge on the capacitor in the circuit at
(a) $t = 0$, (b) $t = 30(\mu)s$, (c) $t = 120(\mu)s$ and (d) $t = 1.0ms$

 [Watch Video Solution](#)

66. A capacitor of capacitance $8.0(\mu)F$ is connected to a battery of emf $6.0V$ through a resistance of $24(\Omega)$. Find the current in the circuit (a) just after the connections are made and (b) one time constant after the connections are made.

 [Watch Video Solution](#)

67. A parallel-plate capacitor of plate area $40cm^2$ and separation between the plates $0.10mm$ is connected to a battery of *emf* $2.0V$ through a 16Ω resistor. Find the electric field in the capacitor $10ns$ after the connections are made.

 [Watch Video Solution](#)

68. A parallel-plate capacitor has plate area 20cm^2 , plate separation 1.0mm and a dielectric slab of dielectric constant 5.0 filling up the space between the plates. This capacitor is joined to a battery of emf 6.0V through a $100\text{k}(\Omega)$ resistor. Find the energy of the capacitor $8.9(\mu)\text{s}$ after the connections are made.



[Watch Video Solution](#)

69. A $100(\mu)\text{F}$ capacitor is joined to a 24V battery through a $1.0\text{M}(\Omega)$ resistor. Plot qualitative graphs (a) between current and time for the first 10 minutes and (b) between charge and time for the same period.



[Watch Video Solution](#)

70. How many time constants will elapse before the current in a charging RC circuit drops to half of its initial value? Answer the same question for a discharging RC circuit.

 [Watch Video Solution](#)

71. How many time constants will elapse before the charge on a capacitor falls to 0.1% of its maximum value in a discharging RC circuit.

 [Watch Video Solution](#)

72. How many time constants will elapse before the energy stored in the capacitor reaches half of its equilibrium value in a charging RC circuit ?

 [Watch Video Solution](#)

73. how many time constants will elapse before the power delivered by the battery drops to half of its maximum value in an RC circuit ?

 [Watch Video Solution](#)

74. A capacitor of capacitance C is connected to a battery of emf (ε) at $t=0$ through a resistance R . Find the maximum

rate at which energy is stored in the capacitor. When does the rate has this maximum value?

 [Watch Video Solution](#)

75. A capacitor of capacitance $12(\mu)F$ is connected to a battery of emf $6.00V$ and internal resistance $1.00(\Omega)$ through resistanceless leads. $12.0(\mu)s$ after the connections are made, what will be (a) the current in the circuit, (b) the power delivered by the battery, (c) the power dissipated in heat and (d) the rate at which the energy stored in the capacitor is increasing.

 [Watch Video Solution](#)

76. A capacitance C charged to a potential difference V is discharged by connecting its plates through a resistance R . Find the heat dissipated in one time constant after the connections are made. Do this by calculating $\int i^2 R dt$ and also by finding the decrease in the energy stored in the capacitor.

 [Watch Video Solution](#)

77. By evaluating $\int i^2 R dt$, show that when a capacitor is charged by connecting it to a battery through a resistor, the energy dissipated as heat equals the energy stored in the capacitor.

 [Watch Video Solution](#)

78. A parallel-plate capacitor is filled with a dielectric material having resistivity (ρ) and dielectric constant K . The capacitor is charged and disconnected from the charging source. The capacitor is slowly discharged through the dielectric. Show that the time constant of the discharge is independent of all geometrical parameters like the plate area or separation between the plates. Find this time constant.

 [Watch Video Solution](#)

79. Find the charge on each of the capacitor 0.20ms after the switch S is closed in Figure.

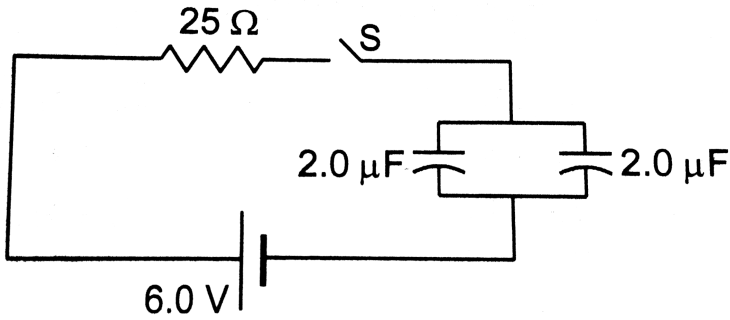

[▶ Watch Video Solution](#)

80. The switch S shown in figure is kept closed for a long time and is then opened at $t = 0$. Find the current in the middle $10(\Omega)$ resistor at $t = 1.0\text{ms}$.

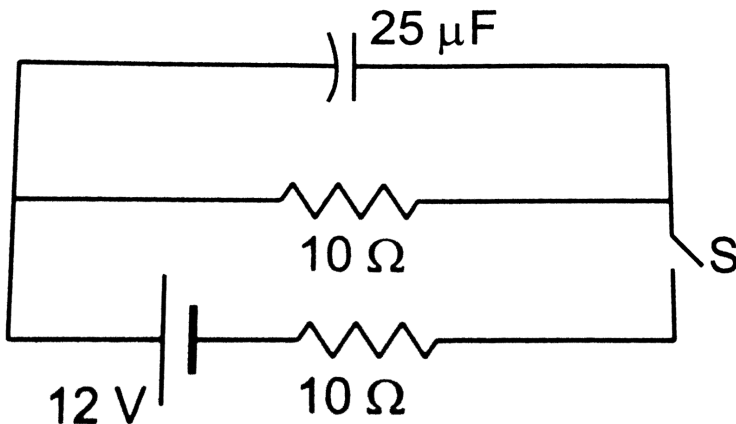



Watch Video Solution

81. A capacitor of capacitance $100(\mu)F$ is connected across a battery of emf $6.0V$ through a resistance of $20k(\Omega)$ for $4.0s$ after the battery is disconnecting?



Watch Video Solution

82. Consider the situation shown in figure. The switch is closed at $t = 0$ when the capacitors are uncharged. Find

the charge on the capacitor C_1 as a function of time t .

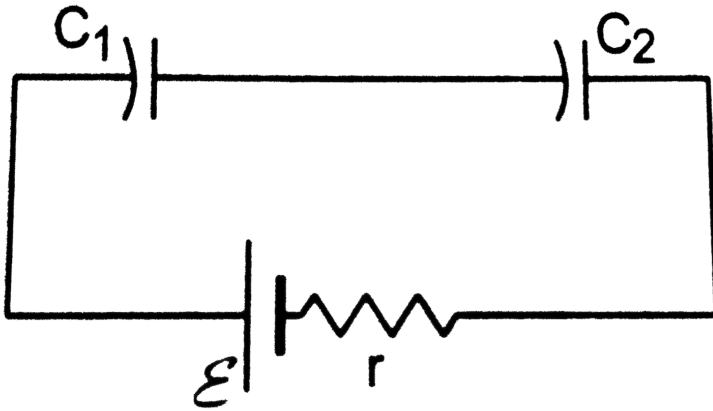

[▶ Watch Video Solution](#)

83. A capacitor of capacitance C is given a charge Q . At $t = 0$, it is connected to an uncharged of equal capacitance through a resistance R . Find the charge on the second capacitor as a function of time.

[▶ Watch Video Solution](#)

84. A capacitor of capacitance as C is given a charge Q . At $t = 0$, it is connected to an ideal battery of emf (ε) through a resistance R . Find the charge on the capacitor at time t .



Watch Video Solution