



PHYSICS

BOOKS - HC VERMA

GEOMETRICAL OPTICS

Example

1. A convex mirror has its radius of curvature $k=20$ cm. Find the position of the image of an object placed at a distance of 12 cm from the

mirror.



[Watch Video Solution](#)

2. An object of length 2.5 cm is placed at a distance of $1.5 f$ from a concave mirror where f is the magnitude of the focal length of the mirror. The length of the object is perpendicular to the principal axis. Find the length of the image. Is the image erect or inverted?



[Watch Video Solution](#)

3. Locate the image of the point object O in the situation shown in figure. The point C denotes the centre of curvature of the separating surface.



[View Text Solution](#)

Examples

1. A printed page is kept pressed to a glass cube ($\mu = 1.5$) of edge 6.0 cm. By what amount will the printed letters appear to be shifted when viewed from the top?



[Watch Video Solution](#)

2. The critical angle for water is 48.2° . Find its refractive index.



[Watch Video Solution](#)

3. The angle of minimum deviation from a prism is 37° . If the angle of prism is 53° , find the refractive index of the material of the prism.



[Watch Video Solution](#)

4. Find the size of the image formed in the situation shown in figure.

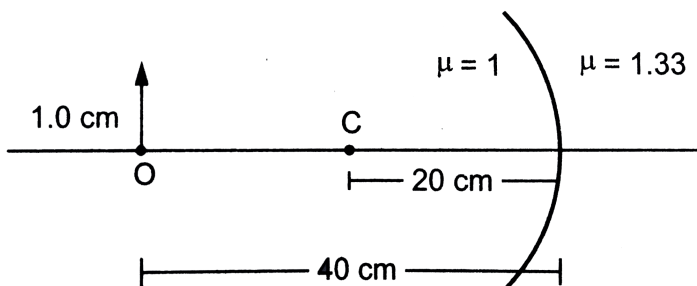

[Watch Video Solution](#)

5. A biconvex lens has radii of curvature 20 cm each. If the refractive index of the material of the lens is 1.5, what is its focal length?



Watch Video Solution

6. An object of length 2.0 cm is placed perpendicular to the principal axis of a convex lens of focal length 12 cm. Find the size of the

image of the object is at a distance of 8.0 cm from the lens.



[Watch Video Solution](#)

Worked Out Examples

1. An object is placed on the principal axis of a concave mirror of focal length 10 cm at a distance of 8.0 cm from the pole. Find the position and the nature of the image.



[Watch Video Solution](#)

2. A rod of length 10 cm lies along the principal axis of a concave mirror of focal length 10 cm in such a way that the end closer to the pole is 20 cm away from it. Find the length of the image.



[Watch Video Solution](#)

3. At what distance from a convex mirror of focal length 2.5 m should a boy stand so that his image has a height equal to half the

original height ? The principal axis is perpendicular to the height.



[Watch Video Solution](#)

4. A 2.0 cm high object is placed on the principal axis of a concave mirror at a distance of 12 cm from the pole. If the image is inverted, real and 5.0 cm high, find the location of the image and focal length of the mirror.



[Watch Video Solution](#)

5. Consider the situation shown in figure. Find the maximum angle θ for which the light suffers total internal reflection at the vertical surface.



[View Text Solution](#)

6. A right angled prism is to be made by selecting a proper material and the angles A and B ($B \leq A$), as shown in figure. It is desired that a ray of light incident on the face AB

emerges parallel to the incident direction after two internal reflections.

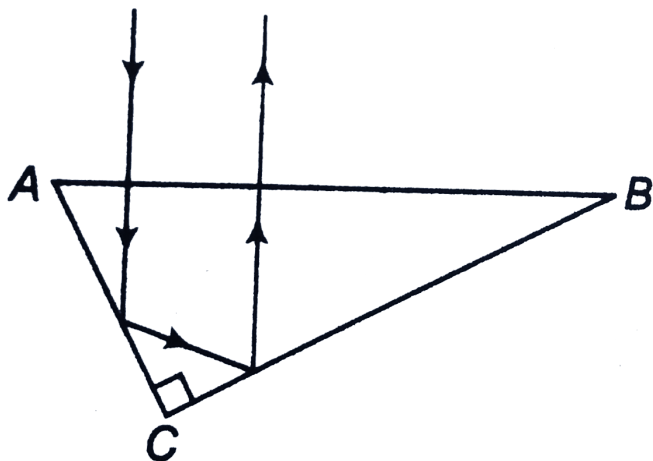

(a) What should be the minimum refractive index n for this to be possible?

(b) For $n = \frac{5}{3}$ is it possible to achieve this with the angle B equal to 30 degrees?



[Watch Video Solution](#)

7. A point object O is placed in front of a transparent slab at a distance x from its surface. It is seen from the other side of the slab by light incident nearly normally to the slab. The thickness of the slab is t and its refractive index is μ . Show that the apparent shift in the position of the object is independent of x and find its value.



[Watch Video Solution](#)

8. Consider the situation shown in figure. A plane mirror is fixed at a height h above the bottom of a beaker containing water (refractive index μ) up of a bottom formed by the mirror.

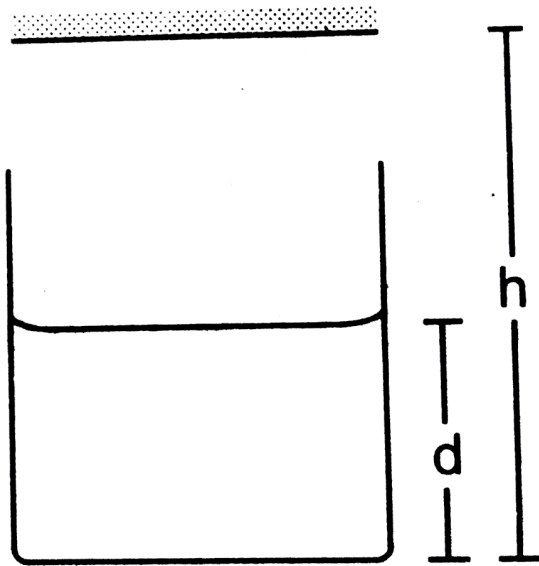

Watch Video Solution

9. A beaker contains water up to a height h_1 and K oil above water up to another height h_2 . Find the apparent shift in the position of the bottom of the beaker when viewed from above. Refractive index of water is μ_1 and that of K oil is μ_2 .



[Watch Video Solution](#)

10. Monochromatic light is incident on the plane interface AB between two media of refractive indices μ_1 and μ_2 ($\mu_2 > \mu_1$) at an angle of incidence θ as shown in figure. The angle θ is infinitesimally greater than the critical angle for the two media so that total internal reflection takes place. Now, if a transparent slab DEFG of uniform thickness and of refractive index μ_2 is introduced on the interface (as shown in figure), show that for any value of μ_2 all light will

ultimately be reflected back into medium II.

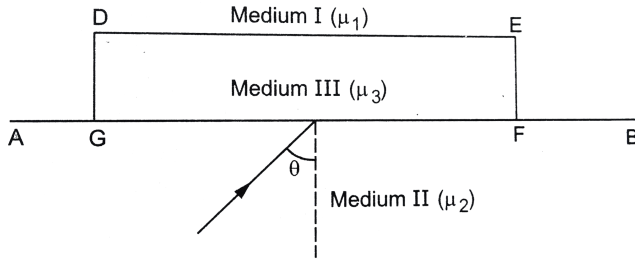

[Watch Video Solution](#)

11. A concave mirror of radius 40 cm lies on a horizontal table and water is filled in it up to a height of 5.00 cm. A small dust particle floats on the water surface at a point P vertically above the point of contact of the mirror with the table. Locate the image of the dust

particle as seen from a point directly above it.

The refractive index of water is 1.33.

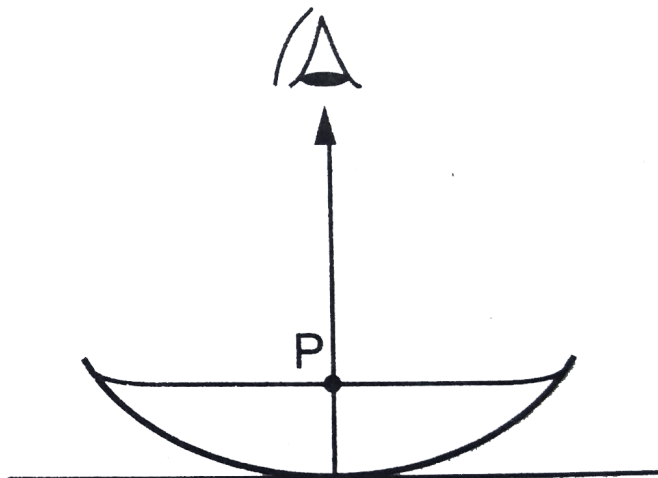

Watch Video Solution

12. An object is placed 21 cm in front of a concave mirror of radius of curvature 20 cm. A

glass slab of thickness 3 cm and refractive index 1.5 is placed close to the mirror in the space between the object and the mirror. Find the position of the final image formed. The distance of the nearer surface of the slab from the mirror is 10 cm.

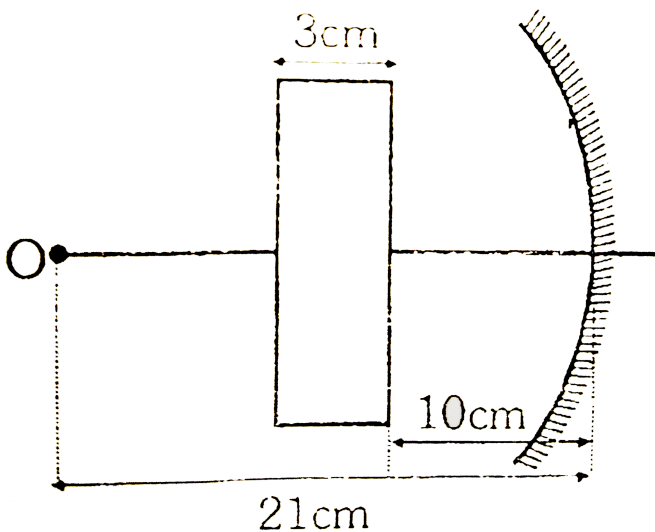

Watch Video Solution

13. The refractive indices of silicate flint glass for wavelength 400 nm and 700 nm are 1.66 and 1.61 respectively. Find the minimum angles of deviation of an equilateral prism made of this glass for light of wavelength 400 nm and 700 nm.



Watch Video Solution

14. Consider the situation shown in figure. Light from a point source S is made parallel by

a convex lens L. The beam travels horizontally and falls on an $88^\circ - 88^\circ - 4^\circ$ prism as shown in figure. It passes through the prism symmetrically. The transmitted light falls on a vertical mirror. Through what angle should the mirror be rotated so that an image of S is formed as S itself?

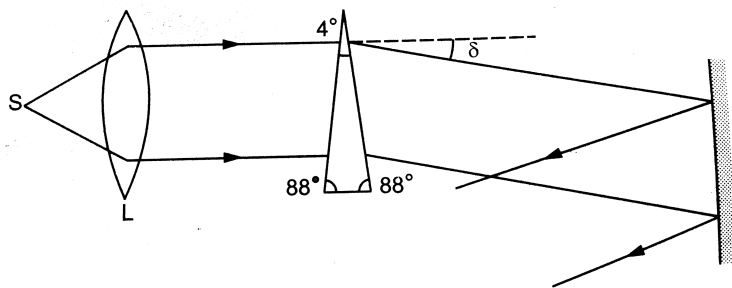

[Watch Video Solution](#)

15. Locate the image formed by refraction in the situation shown in figure. The point C is the centre of curvature

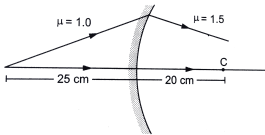

Watch Video Solution

16. One end of a horizontal cylindrical glass rod ($\mu = 1.5$) of radius 5.0 cm is rounded in the shape of a hemisphere. An object 0.5 mm high is placed perpendicular to the axis of the

rod at a difference of 20.0 cm from the rounded edge. Locate the image of the object and find its height.



[Watch Video Solution](#)

17. There is a small air bubble inside a glass sphere ($\mu = 1.5$) of radius 10 cm. The bubble is 4.0cm below the surface and is viewed normally from the outside. Find the apparent

depth of the bubble.

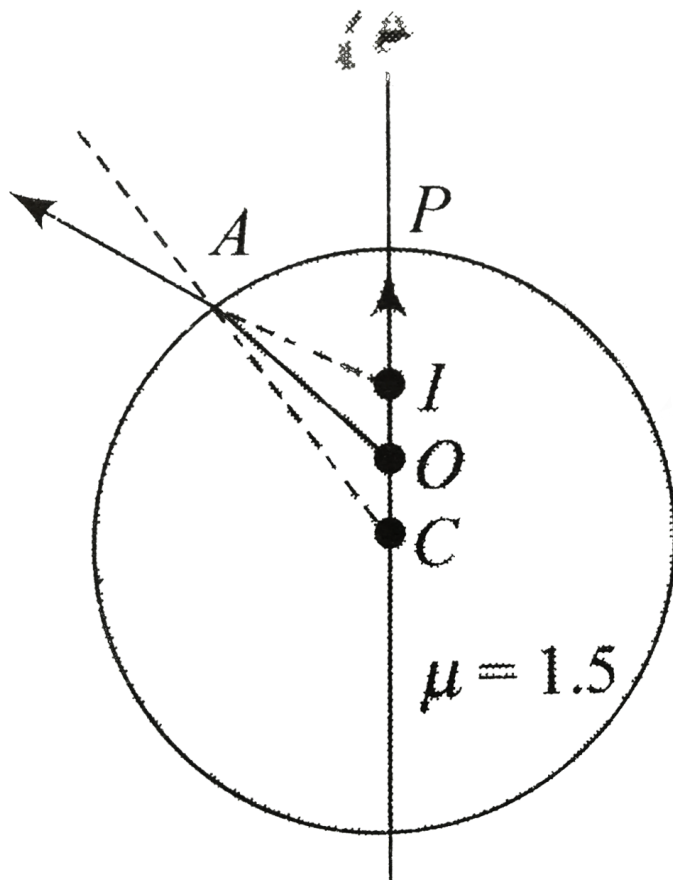

Watch Video Solution

18. A parallel beam of light travelling in water (refractive index = $\frac{4}{3}$) is refracted by a spherical bubble of radius 2 mm situated in water. Assuming the light rays to be paraxial. Find the position of the image due to refraction at the first surface and the position of the final image



Watch Video Solution

19. Calculate the focal length of the thin lens shown in figure. The points C_1 and C_2 denote the centres of curvature.

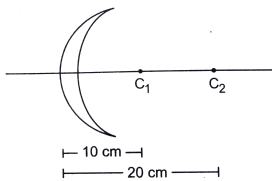

Watch Video Solution

20. A point source S is placed at distance of 15 cm from a converging lens of focal length 10 cm. Where should a (i) concave mirror (ii)

convex mirror of focal length 12 cm be placed so that real image is formed on object itself.



Watch Video Solution

21. A conveying lens of focal length 15 cm and a converging mirror of focal length 20 cm are placed with their principal axes coinciding. A point source S is placed on the principal axis at a distance of 12 cm from the lens as shown in figure. It is found that the final beam comes out parallel to the principal axis. Find the

separation between the mirror and the lens.

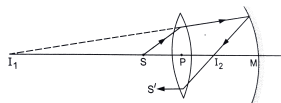

Watch Video Solution

22. A biconvex thin lens is prepared from glass ($\mu = 1.5$), the two bounding surfaces having equal radii of 25 cm each. One of the surfaces is silvered from outside to make it reflecting. Where should an object be placed before this lens so that the image is formed on the object

itself?

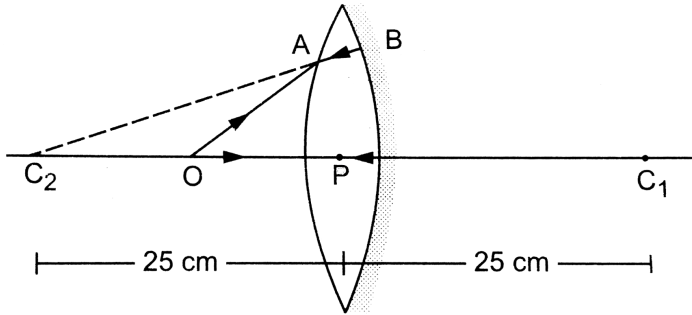

[Watch Video Solution](#)

23. A concave convex figure lens made of glass ($\mu = 1.5$) has surface of radii 20 cm and 60 cm. a. Locate the image of an object placed 80 cm to the left of the lens along the principal axis. B. A similar lens is placed coaxially at

distance of 160 cm right of it. Locate the position of the image.

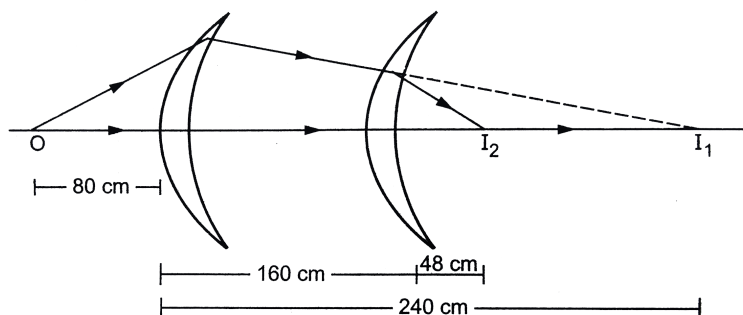

[Watch Video Solution](#)

24. A thin lens of focal length + 12 cm is immersed in water ($\mu = 1.33$). What is its new focal length ?



[Watch Video Solution](#)

25. A long cylindrical tube containing water is closed by an equiconvex lens of focal length 10 cm in air. A point source is placed along the axis of the tube outside it at a distance of 21 cm from the lens. Locate the final image of the source. Refractive index of the material of the lens = 1.5 and $n_{\text{water}} = 1.33$.



[Watch Video Solution](#)

26. A slide projector produces 500 times enlarged image of a slide on a screen 10 m away. Assume that the projector consists of a single convex lens used for magnification. If the screen is moved 2.0 m closer, by what distance should the slide be moved towards or away from the lens so that the image remains focused on the screen ? What is the magnification in this case ?



Watch Video Solution

27. A convex lens focusses an object 10 cm from it on a screen placed 10 cm away from it. A glass plate ($\mu = 1.5$) of thickness 1.5 cm is inserted between the lens and the screen. Where should the object be placed so that its image is again focussed on the screen?



[Watch Video Solution](#)

28. Two convex lenses of focal length 20 cm each are placed coaxially with a separation of 60 cm between them. Find the image of a

distance object formed by the combination by
a. using thin lens formula separately for the two
lenses and b. using the equivalent lens. Note
that although the combination forms a real
image of as distance object on the other side,
it is equivalent to as diverging lens as far as
the location of the final image is concerned.



[Watch Video Solution](#)

Short Answer

1. Is the formula "Real depth/Apparent depth = μ ." valid if viewed from a position quite away from the normal ?



[Watch Video Solution](#)

2. Can you ever have a situation in which a light ray goes undeviated through a prism ?



[Watch Video Solution](#)

3. Why does a diamond shine more than a glass piece cut to the same shape? (AS_7)



Watch Video Solution

4. A narrow beam of light passes through a slab obliquely and is then received by an eye. The index of refraction of the material in the slab fluctuates slowly with time. How will it appear to the eye? The twinkling of stars has a

similar explanation.

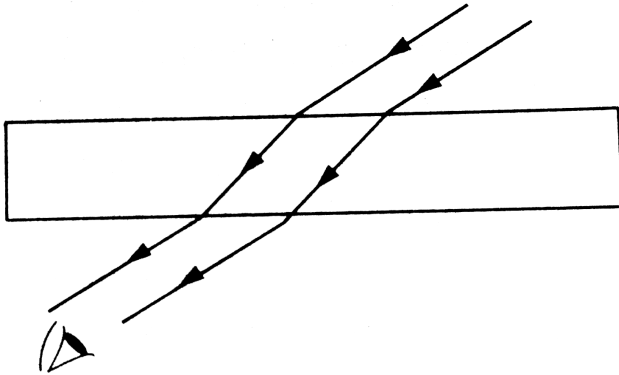

Watch Video Solution

5. Can a plane mirror ever form a real image ?



Watch Video Solution

6. If a piece of paper is placed at the position of a virtual image of a strong light source, will the paper burn after sufficient time ? What happens if the image is real? What happens if the image is real but the source is virtual ?



[Watch Video Solution](#)

7. Can a virtual image be photographed by a camera ?



[Watch Video Solution](#)

8. In motor vehicles, a convex mirror is attached near the driver's seat to give him the view of the traffic behind. What is the special function of this convex mirror which a plane mirror can not do ?



[Watch Video Solution](#)

9. If an object far away from a convex mirror moves towards the mirror, the image also

moves. Does it move faster, slower or at the same speed as compared to the object ?



[Watch Video Solution](#)

10. Suppose you are inside the water in a swimming pool near an edge. A friend is standing on the edge. Do you find your friend taller or shorter than his usual height ?



[Watch Video Solution](#)

11. The equation of refraction at a spherical surface is $\frac{\mu_2}{v} - \frac{\mu_1}{u} = \frac{\mu_2 - \mu_1}{R}$

Taking $R = \infty$, show that this equation leads to the equation

$\frac{\text{Realdepth}}{\text{Apparentdepth}} = \frac{\mu_1}{\mu_2}$ for fraction at a plane surface.



Watch Video Solution

12. A thin converging lens is formed with one surface convex and the other plane. Does the

position of image depend on whether the convex surface or the plane surface faces the object ?



[Watch Video Solution](#)

13. A single lens is mounted in a tube. A parallel beam enters the tube and emerges out of the tube as a divergent beam. Can you say with certainty that there is a diverging lens in the tube ?



[Watch Video Solution](#)

14. An air bubble is formed inside water. Does it act as a converging lens or a diverging lens ?



Watch Video Solution

15. If a thin lens is dipped in water, does its focal length change ?



Watch Video Solution

16. If a thin lens is dipped in water, does its focal length change ?



Watch Video Solution

17. Explain error of chromatic aberration.



Watch Video Solution

18. A laser light is focussed by a converging lens. Will there be a significant chromatic

aberration ?



[Watch Video Solution](#)

Question For Short Answer

1. Two converging lenses of unequal focal lengths can be used to reduce the aperture of a parallel beam of light without losing the energy of the light. This increases the intensity. Describe how the converging lenses should be placed to do this.



Watch Video Solution

Objective 1

1. A point source of light is placed in front of a plane mirror.

A. All the reflected rays meet at a point when produced backward

B. Only the reflected rays close to the normal meet at a point when produced

backward

C. only the reflected rays making a small angle with the mirror meet at point when produced backward.

D. light of different colours make different images

Answer: A



Watch Video Solution

2. Total internal reflection can take only if

A. light goes from optically rarer medium
(smaller refractive index) to optically
denser medium

B. light goes from optically denser medium
to rarer medium

C. the refractive indices of the two media
are close to each other

D. the refractive indices of the two media
are widely different

Answer: B



Watch Video Solution

3. In image formation from spherical mirrors,
only paraxial rays are considered because they

A. are easy to handle geometrically

B. contain most of the intensity of the
incident light

C. form nearly a point image of a point
source

D. show minimum dispersion effect

Answer: C



Watch Video Solution

4. A point object is placed at distance of 30 cm in front of a convex mirror of Focal length 30 cm. The image will form at

A. infinity

B. pole

C. focus

D. 15 cm behind the mirror

Answer: D



Watch Video Solution

5. Figure shows two rays A and B being reflected by a mirror and going as A' and B'. The mirror

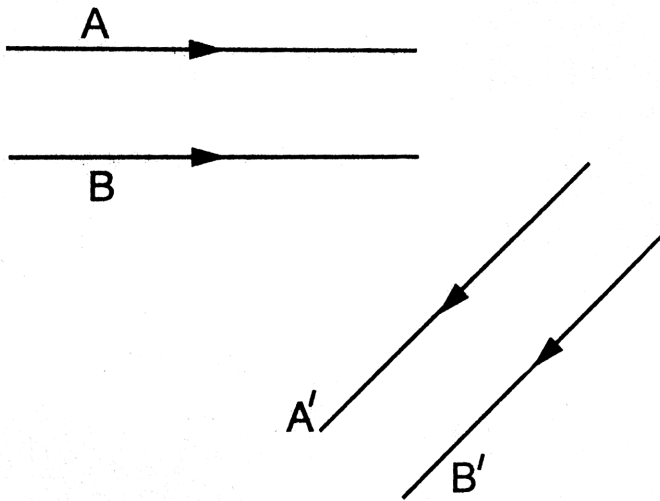

A. is plane

B. is convex

C. is concave

D. may be any spherical mirror

Answer: A



Watch Video Solution

6. The image formed by a concave mirror

A. is always real

B. is always virtual

C. is certainly real if the object is virtual

D. is certainly virtual if the object is real

Answer: C



Watch Video Solution

7. Figure shows figure three transparent medi of refractive indices μ_1 , μ_2 and μ_3 . A point object O is placed in the medium μ_2 . If the entire medium on the right of the spherical surface has refractive index μ_1 , the image forms at O. If this entire medium has refractive index μ_2 the image form at O". In the situation

shown

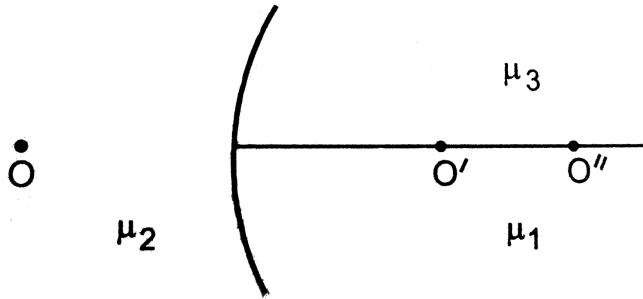

- A. the image forms between O' and O''
- B. the image forms to the left of O'
- C. the image forms to the right of O'
- D. two images form one at O' and the other at O''

Answer: D



Watch Video Solution

8. Four modifications are suggested in the lens formula to include the effect of the thickness t of the lens. Which one is likely to be correct?

A.
$$\frac{1}{v} - \frac{1}{u} = \frac{t}{uf}$$

B.
$$\frac{t}{v^2} - \frac{1}{u} = \frac{1}{f}$$

C.
$$\frac{1}{v-t} - \frac{1}{v+t} = \frac{1}{f}$$

D.
$$\frac{1}{v} - \frac{1}{u} + \frac{t}{uv} = \frac{t}{f}$$

Answer: C



Watch Video Solution

9. A double convex lens has two surfaces of equal radii R and refractive index $m=1.5$, we have

A. $f = \frac{R}{2}$

B. $f = R$

C. $f = -R$

D. $f = 2R$

Answer: B



Watch Video Solution

10. A point source of light is placed at a distance of $2f$ from a converging lens of focal length f . The intensity on the other side of the lens is maximum at a distance

- A. f
- B. between f and $2f$
- C. $2f$
- D. more than $2f$

Answer: C



Watch Video Solution

11. A parallel beam of light is incident on a converging lens parallel to its principal axis. As one moves away from the lens on the other side on its principal axis, the intensity of light

- A. remains constant
- B. continuously increases
- C. continuously decreases

D. first increases then decreases

Answer: D



Watch Video Solution

12. A symmetric double convex lens is cut in two equal parts by a plane perpendicular to the principal axis. If the power of the original lens was $4D$, the power of a cut lens will be

A. $2D$

B. 3D

C. 4D

D. 5D

Answer: A



Watch Video Solution

13. A symmetric double convex lens is cut in two equal parts by a plane perpendicular to the principal axis. If the power of the original lens was 4D, the power of a cut lens will be

A. 2D

B. 3D

C. 4D

D. 5D

Answer: C



Watch Video Solution

14. Two concave lenses L_1 and L_2 are kept in contact with each other. If the space between the two lenses is filled with a material of

smaller refractive index, the magnitude of the focal length of the combination

A. becomes undefined

B. remains unchanged

C. increases

D. decreases

Answer: C



Watch Video Solution

15. A thin lens is made with a material having refractive index $\mu = 1.5$. Both the sides are convex. It is dipped in water ($\mu = 1.33$). It will behave like

A. a convergent lens

B. a diverge lens

C. a rectangular slab

D. a prism

Answer: A



Watch Video Solution

16. A convex lens is made of a material having refractive index 1.2. Both the surface of the lens are convex. If it is dipped into water ($\mu = 1.33$) it will behave like

- A. a convergent lens
- B. a divergent lens
- C. a rectangular slab
- D. a prism

Answer: B



Watch Video Solution

17. A point object O is placed on the principal axis of a convex lens of focal length $f = 20\text{cm}$ at a distance of 40 cm to the left of it. The diameter of the lens is 10. An eye is placed 60 cm to right of the lens and a distance h below the principal axis. The maximum value of h to see the image is

A. 0

B. 2.5 cm

C. 5 cm

D. 10 cm

Answer: B



Watch Video Solution

18. The rays of different colours fail to converge at a point after going through a converging lens. This defect is called

A. spherical aberration

B. distortion

C. coma

D. chromatic aberration

Answer: D



Watch Video Solution

Objective 2

1. If the light moving in a straight line bends by a small but fixed angle it may be a case of

A. Reflection

B. refraction

C. diffraction

D. dispersion

Answer: A::B



Watch Video Solution

2. mark the correct options.

A. If the incident rays are converging we have a real object.

B. If the final rays are converging we have a real image

C. The image of virtual object is called a virtual image

D. if the image is virtual the corresponding object is called virtual object

Answer: B



Watch Video Solution

3. Which of the following (referred to a sphericka mirror) do (does) not depend on whether the rays are paraxial or not?

A. pole

B. focus

C. radius of curvature

D. principal axis

Answer: A::B::C



Watch Video Solution

4. The image of an extend object placed perpendicular to the principal axis of a mirror, will be erect if

A. the object and the image are both real

B. the object and the image are both
virtual

C. the object is real but the image is virtual

D. the object is virtual but the image is real

Answer: C::D



Watch Video Solution

5. A convex forms a real image of a point object placed on its principal axis. If the upper half of the lens is painted black

A. the image will be shifted downward

B. the image will be shifted upward

C. the image will not be shifted

D. the intensity of the image will decrease

Answer: C::D



Watch Video Solution

6. consider three converging lenses L_1 , L_2 and L_3 having identical geometrical construction. The index of refraction of L_1 and L_2 are μ_1 and μ_2 respectively. The upper half of the lens L_3 has a refractive index

μ_1 and the lower half has μ_2 . A point object O is imaged at O_1 by the lens L_1 and at O_2 by the lens L_2 placed in same position . If L_2 is placed at the same place.

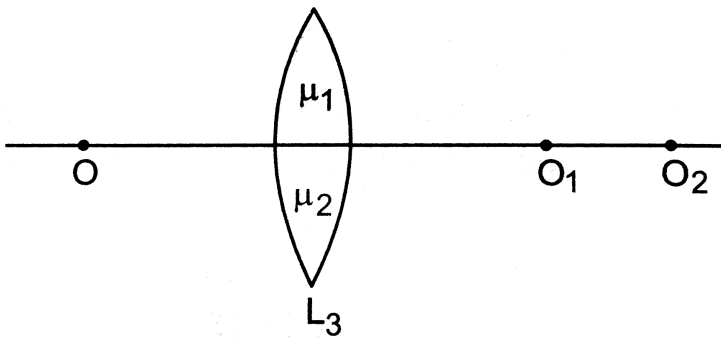

- A. there will be n image at O
- B. there will be an image t O_2
- C. the only imge will form somewhere between O_1 and O_2 .

D. the only image will form away from O .

Answer: A::B



Watch Video Solution

7. A screen is placed a distance 40 cm away from an illuminated object. A converging lens is placed between the source and the screen and it is attempted to form the image of the source on the screen. If no position could be found, the focal length of the lens

A. must be less than 10 cm

B. must be greater than 20 cm

C. must not be greater than 20 cm

D. must not be less than 10 cm

Answer: B



Watch Video Solution

Exercises

1. A concave mirror having a radius of curvature 40 cm is placed in front of an illuminated point source at a distance of 30 cm from it. Find the location of the image.



[Watch Video Solution](#)

2. A concave mirror forms an image of 20 cm high object on a screen placed 5.0 m away from the mirror. The height of the image is 50

cm. Find the focal length of the mirror and the distance between the mirror and the object.



[Watch Video Solution](#)

3. A concave mirror has a focal length of 20 cm. Find the position or positions of an object for which the image-size is double of the object-size.



[Watch Video Solution](#)

4. A 1 cm object is placed perpendicular to the principal axis of a convex mirror of focal length 7.5 cm. Find its distance from the mirror if the image formed is 0.6 cm in size.



[Watch Video Solution](#)

5. A candle flame 1.6 cm high is imaged in a ball bearing of diameter 0.4 cm. If the ball bearing is 20 cm away from the flame, find the location and the height of the image.





[Watch Video Solution](#)

6. A 3 cm tall object is placed at a distance of 7.5 cm from a convex mirror of focal length 6 cm. Find the location, size and nature of the image.



[Watch Video Solution](#)

7. A U-shaped wire is placed before a concave mirror having radius of curvature 20cm as shown in figure,. Find the total length of the

image.

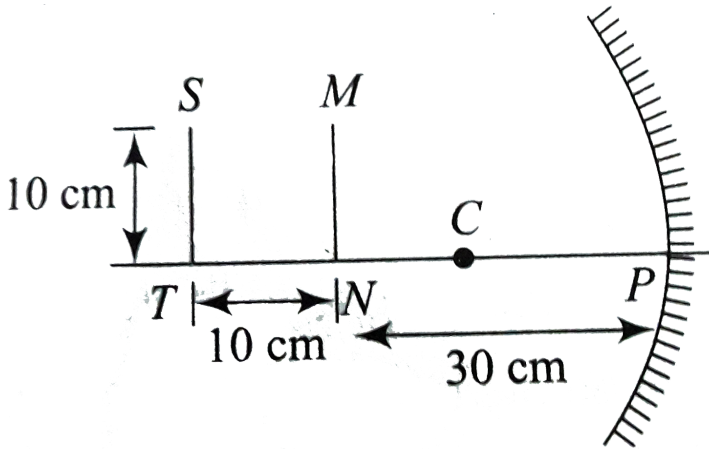

[Watch Video Solution](#)

8. A man uses a concave mirror for shaving. He keeps his face at a distance of 25 cm from the mirror and gets an image which is 1.4 times enlarged. Find the focal length of the mirror



[Watch Video Solution](#)

9. Find the diameter of the image of the moon formed by a spherical concave mirror of focal length 7.6 m. The diameter of the moon is 3450 km and the distance of the earth and the moon is $3.8 \times 10^5 \text{ km}$.



[Watch Video Solution](#)

10. A particle goes in a circle of radius 2.0 cm. A concave mirror of focal length 20 cm is placed with its principal axis passing through the centre of the circle and perpendicular to its plane. The distance between the pole of the mirror and the centre of the circle is 30 cm. Calculate the radius of the circle formed by the image.



Watch Video Solution

11. A concave mirror of radius R is kept on a horizontal table. Water (refractive index $=\mu$.) is poured into it up to a height h . Where should an object be placed so that its image is formed on itself ?



Watch Video Solution

12. A point source S is placed midway between two converging mirrors having equal focal

length f as shown in figure. Find the values of d for which only one image is formed.

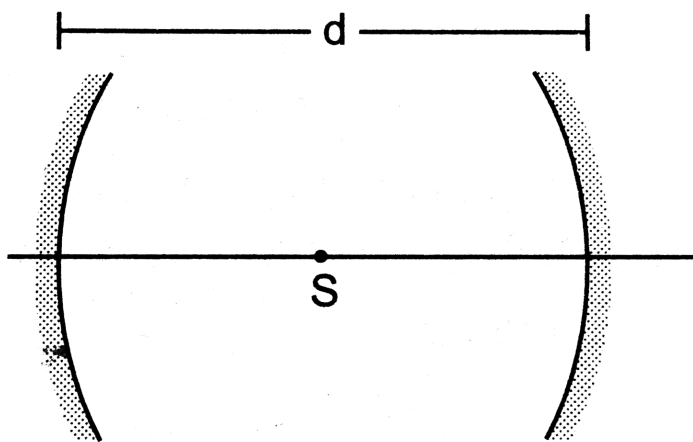

[Watch Video Solution](#)

13. A converging mirror M_1 a point source S and a diverging mirror M_2 are arranged as shown in figure. The source is placed at a

distance of 30 cm from M_1 . The focal length of each of the mirrors is 20 cm. Consider only the images formed by a maximum of two reflections. It is found that one image is formed on the source itself. (a) Find the distance between the two mirrors. (b) Find the location of the image formed by the single reflection from M_2



Watch Video Solution

14. A light ray falling at an angle of 45° with the surface of a clean slab of ice of thickness 1.00 m is refracted into it at an angle of 30° . Calculate the time taken by the light rays to cross the slab. Speed of light in vacuum $= 3 \times 10^8 \text{ m s}^{-1}$



Watch Video Solution

15. A pole of length 1.00 m stands half dipped in a swimming pool with water level 50.0 cm

higher than the bed. The refractive index of water is 1.33 and sunlight is coming at an angle of 45° with the vertical. Find the length of the shadow of the pole on the bed.



[Watch Video Solution](#)

16. A small piece of wood is floating on the surface of a 2.5 m deep lake. Where does the shadow form on the bottom when the sun is just setting? Refractive index of water = $4/3$



[Watch Video Solution](#)

17. An object P is focussed by a microscope M. A glass slab of thickness 2.1 cm is introduced between P and M. If the refractive index of the slab is 1.5, by what distance should the microscope be shifted to focus the object again ?



Watch Video Solution

18. A vessel contains water up to a height of 20 cm and above it an oil up to another 20 cm.

The refractive indices of the water and the oil are 1.33 and 1.30 respectively. Find the apparent depth of the vessel when viewed from above.



[Watch Video Solution](#)

19. Locate the image of the point P as seen by the eye in the figure



[Watch Video Solution](#)

20. k transparent slabs are arranged one over another. The refractive indices of the slabs are $\mu_1, \mu_2, \dots, \mu_k$ and the thicknesses are $t_1, t_2, t_3, \dots, t_k$. An object is seen through this combination with nearly perpendicular light. Find the equivalent refractive index of the system which will allow the image to be formed at the same place.



[Watch Video Solution](#)

21. A cylindrical vessel of diameter 12 cm contains $800\pi \text{ cm}^3$ of water. A cylindrical glass piece of diameter 8.0 cm and height 8.0 cm is placed in the vessel. If the bottom of the vessel under the glass piece is seen by the paraxial rays (see figure 18-E6), locate its image. The index of refraction of glass is 1.50 and that of water is 1.33



[Watch Video Solution](#)

22. Consider the situation in figure. The bottom of the pot is a reflecting plane mirror, S is a small fish and T is a human eye. Refractive index of water is μ . (a) At what distance(s) from itself will the fish see the image(s) of the eye ? (b) At what distance(s) from itself will the eye see the image(s) of the fish.



Watch Video Solution

23. A small object is placed at the centre of the bottom of a cylindrical vessel of radius 3 cm and height 4 cm filled completely with water. Consider the ray leaving the vessel through a corner. Suppose this ray and the ray along the axis of the vessel are used to trace the image. Find the apparent depth of the image and the ratio of real depth to the apparent depth under the assumptions taken. Refractive index of water = 1.33.



Watch Video Solution

24. A cylindrical vessel, whose diameter and height both are equal to 30 cm, is placed on a horizontal surface and a small particle P is placed in it at a distance of 5.0 cm from the centre. An eye is placed at a position such that the edge of the bottom is just visible (see figure 18-E8). The particle P is in the plane of drawing. Up to what minimum height should water be poured in the vessel to make the particle P visible ?



Watch Video Solution

25. A light ray is incident at an angle of 45° with the normal to a $\sqrt{2}$ cm thick plate ($\mu = 2.0$). Find the shift in the path of the light as it emerges out from the plate.



Watch Video Solution

26. An optical fibre ($\mu = 1.72$) is surrounded by a glass coating ($\mu = 1.50$). Find the critical angle for total internal reflection at the fibre-glass interface.



Watch Video Solution

27. A light ray is incident normally on the face AB of a right-angled prism ABC ($\mu = 1.50$) as shown in figure. What is the largest angle ϕ for which the light ray is totally reflected at the surface AC ?



Watch Video Solution

28. Find the maximum angle of refraction when a light ray is refracted from glass ($\mu = 1.50$) to air.



Watch Video Solution

29. Light is incident from glass ($\mu = 1.5$) to air. Sketch the variation of the angle of deviation δ with angle of incident i for $0 < i < 90^\circ$



Watch Video Solution

30. Light is incident from glass ($\mu = 1.50$) to water ($\mu = 1.33$) find the range of the angle of deviation for which there are two angles of incidence.



Watch Video Solution

31. Light falls from glass ($\mu = 1.5$) to air. Find the angle of incidence for which the angle of deviation is 90° .



Watch Video Solution

32. A point source is placed at a depth h below the surface of water (refractive index = μ). (a) Show that light escapes through a circular area on the water surface with its centre directly above the point source. (b) Find the angle subtended by a radius of the area on the source.



Watch Video Solution

33. A container contains water up to a height of 20 cm and there is a point source at the centre of the bottom of the container. A rubber ring of radius r floats centrally on the water. The ceiling of the room is 2.0 m above the water surface.

(a) Find the radius of the shadow of the ring formed on the ceiling if $r = 15$ cm.

(b) Find the maximum value of r for which the shadow of the ring is formed on the ceiling.

Refractive index of water $= 4/3$.



Watch Video Solution

34. Find the angle of minimum deviation for an equilateral prism made of a material of refractive index 1.732. What is the angle of incidence for this deviation ?



Watch Video Solution

35. Find the angle of deviation suffered by the light ray shown in figure. The refractive index

$\mu =$ for the prism material.

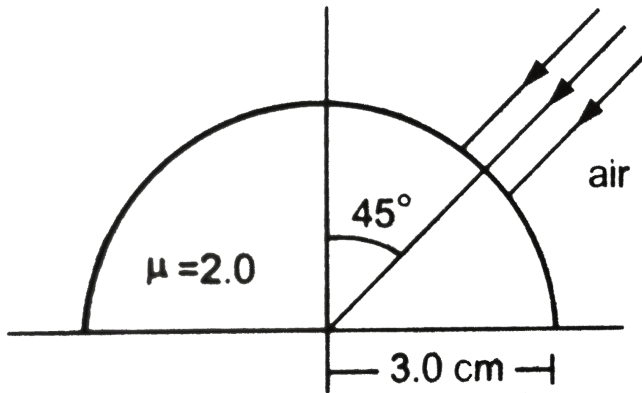

[Watch Video Solution](#)

36. A light ray, going through a prism with the angle of prism 60° , is found to deviate by 30° . What limit on the refractive index can be put from these data ?



Watch Video Solution

37. Locate the image formed by refraction in the situation shown in figure

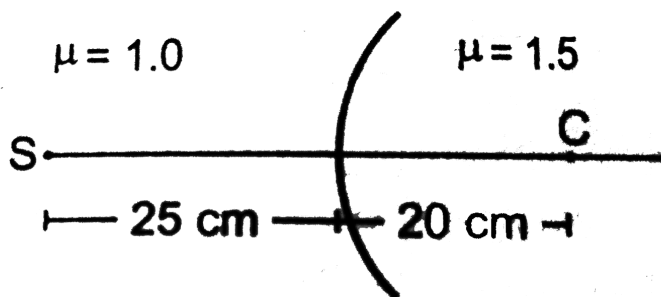

Watch Video Solution

38. A spherical surface of radius 30 cm separates two transparent media A and B with refractive indices 1.33 and 1.48 respectively. The medium A is on the convex side of the surface. Where should a point object be placed in medium A so that the paraxial rays become parallel after refraction at the surface ?



Watch Video Solution

39. Figure shows a transparent hemisphere of radius 3.0 cm made of a material of refractive index 2.0. (a) A narrow beam of parallel rays is incident on the hemisphere as shown in the figure. Are the rays totally reflected at the plane surface? (b) Find the image formed by the refraction at the first surface. (c) Find the image formed by the reflection or by the refraction at the plane surface. (d) Trace qualitatively the final rays as they come out of the hemisphere.



Watch Video Solution

40. A small object is embedded in a glass sphere ($\mu = 1.5$) of radius 5.0 cm at a distance 1.5 cm left to the centre. Locate the image of the object as seen by an observer standing (a) to the left of the sphere and (b) to the right of the sphere.



Watch Video Solution

41. A biconvex thick lens is constructed with glass ($\mu = 1.50$). Each of the surfaces has a radius of 10 cm and the thickness at the middle is 5 cm. Locate the image of an object placed far away from the lens.



Watch Video Solution

42. A narrow pencil of parallel light is incident normally on a solid transparent sphere of radius r . What should be the refractive index if

the pencil is to be focussed (a) at the surface of the sphere, (b) at the centre of the sphere.



Watch Video Solution

43. One end of a cylindrical glass rod ($\mu = 1.5$) of radius 1.0 cm is rounded in the shape of a hemisphere. The rod is immersed in water ($\mu = 4/3$) and an object is placed in the water along the axis of the rod at a distance of 8.0 cm from the rounded edge. Locate the image of the object.



[Watch Video Solution](#)

44. A paperweight in the form of a hemisphere of radius 3.0 cm is used to hold down a printed page. An observer looks at the page vertically through the paperweight. At what height above the page will the printed letters near the centre appear to the observer ?



[Watch Video Solution](#)

45. Solve the previous problem if the paperweight is inverted at its place so that the spherical surface touches the paper



Watch Video Solution

46. A hemispherical portion of the surface of a solid glass sphere ($\mu = 1.5$) of radius r is silvered to make the inner side reflecting. An object is placed on the axis of the hemisphere at a distance $3r$ from the centre of the sphere.

The light from the object is refracted at the unsilvered part, then reflected from the silvered part and again refracted at the unsilvered part. Locate the final image formed.



[Watch Video Solution](#)

47. The convex surface of a thin concave-convex lens of glass of refractive index 1.5 has a radius of curvature 20 cm. The concave surface has a radius of curvature 60 cm. The convex side is silvered and placed on a

horizontal surface as shown in figure. (a) Where should a pin be placed on the axis so that its image is formed at the same place ? (b) If the concave part is filled with water ($\mu = 4/3$), find the distance through which the pin should be moved so that the image of the pin again coincides with the pin.



[Watch Video Solution](#)

48. A double convex lens has focal length 25 cm. The radius of curvature of one of the

surfaces is double of the other. Find the radii, if the refractive index of the material of the lens is 1.5.



[Watch Video Solution](#)

49. The radii of curvature of a lens are + 20 cm and + 30 cm. The material of the lens has a refracting index 1.6. Find the focal length of the lens (a) if it is placed in air, and (b) if it is placed in water ($\mu = 1.33$).



[Watch Video Solution](#)

50. Lenses are constructed by a material of refractive index 1.50. The magnitude of the radii of curvature are 20 cm and 30 cm. Find the focal lengths of the possible lenses with the above specifications.



Watch Video Solution

51. A thin lens made of a material of refractive index μ_2 has a medium of refractive index μ_1 on one side and a medium of refractive index

on the other side. The lens is biconvex and the two radii of curvature have equal magnitude R . A beam of light travelling parallel to the principal axis is incident on the lens. Where will the image be formed if the beam is incident from (a) the medium μ_1 , and (b) from the medium μ_3 ?



[Watch Video Solution](#)

52. A convex lens has a focal length of 10 cm. Find the location and nature of the image if a

point object is placed on the principal axis at a distance of (a) 9.8 cm, (b) 10.2 cm from the lens.



[Watch Video Solution](#)

53. A slide projector has to project a 35 mm slide ($35\text{mm} \times 23\text{mm}$) on a 2 m x 2m screen at a distance of 10 m from the lens. What should be the focal length of the lens in the projector ?



[Watch Video Solution](#)

54. A particle executes a simple harmonic motion of amplitude 1.0 cm along the principal axis of a convex lens of focal length 12 cm. The mean position of oscillation is at 20 cm from the lens. Find the amplitude of oscillation of the image of the particle.



Watch Video Solution

55. An extended object is placed at a distance of 5.0 cm from a convex lens of focal length 8.0

cm. (a) Draw the ray diagram (to the scale) to locate the image and from this, measure the distance of the image from the lens, (b) Find the position of the image from the lens formula and see how close the drawing is to the correct result.



Watch Video Solution

56. A pin of length 2.00 cm is placed perpendicular to the principal axis of a converging lens. An inverted image of size 1.00

cm is formed at a distance of 40.0 cm from the pin. Find the focal length of the lens and its distance from the pin.



[Watch Video Solution](#)

57. A convex lens produces a double size real image when an object is placed at a distance of 18 cm from it. Where should the object be placed to produce a triple size real image ?



[Watch Video Solution](#)

58. A pin of length 2.0 cm lies along the principal axis of a converging lens, the centre being at a distance of 11 cm from the lens. The focal length of the lens is 6 cm. Find the size of the image.



Watch Video Solution

59. The diameter of the sun is $1.4 \times 10^9 \text{ m}$ and its distance from the earth is $1.5 \times 10^{11} \text{ m}$. Find the radius of the image of the sun formed by a lens of focal length 20 cm.



[Watch Video Solution](#)

60. A 5.0 diopter lens forms a virtual image which is 4 times the object placed perpendicularly on the principal axis of the lens. Find the distance of the object from the lens.



[Watch Video Solution](#)

61. A diverging lens of focal length 12 cm and a converging mirror of focal length 10 cm are placed coaxially at a separation of 5 cm. Where should an object be placed so that a real image is formed at the object itself ?



Watch Video Solution

62. A converging lens of focal length 12 cm and a diverging mirror of focal length 7.5 cm are placed 5.0 cm apart with their principal axes

coinciding. Where should an object be placed so that its image falls on itself ?



[Watch Video Solution](#)

63. A converging lens and a diverging mirror are placed at a separation of 15 cm. The focal length of the lens is 25 cm and that of the mirror is 40 cm. Where should a point source be placed between the lens and the mirror so that the light, after getting reflected by the

mirror and then getting transmitted by the lens, comes out parallel to the principal axis ?



[Watch Video Solution](#)

64. A converging lens of focal length 15 cm and a converging mirror of focal length 10 cm are placed 50 cm apart with common principal axis. A point source is placed in between the lens and the mirror at a distance of 40 cm from the lens. Find the locations of the two images formed.



[Watch Video Solution](#)

65. Consider the situation described in the previous problem. Where should a point source be placed on the principal axis so that the two images form at the same place ?



[Watch Video Solution](#)

66. A converging lens of focal length 15 cm and a converging mirror of focal length 10 cm are placed 50 cm apart. If a pin of length 2.0 cm is

placed 30 cm from the lens farther away from the mirror, where will the final image form and what will be the size of the final image ?



[Watch Video Solution](#)

67. A point object is placed on the principal axis of a convex lens ($f = 15$ cm) at a distance of 30 cm from it. A glass plate ($\mu = 1.50$) of thickness 1 cm is placed on the other side of the lens perpendicular to the axis. Locate the image of the point object.



[Watch Video Solution](#)

68. A convex lens of focal length 20 cm and a concave lens of focal length 10 cm are placed 10 cm apart with their principal axes coinciding. A beam of light travelling parallel to the principal axis and having a beam diameter 5.0 mm, is incident on the combination. Show that the emergent beam is parallel to the incident one. Find the beam diameter of the emergent beam.



[Watch Video Solution](#)

69. A diverging lens of focal length 20 cm and a converging lens of focal length 30 cm are placed 15 cm apart with their principal axes coinciding. Where should an object be placed on the principal axis so that its image formed at infinity ?



Watch Video Solution

70. A 5 mm high pin is placed at a distance of 15 cm from a convex lens of focal length 10 cm.

A second lens of focal length 5 cm is placed 40 cm from the first lens and 55 cm from the pin. Find (a) the position of the final image, (b) its nature and (c) its size.



[Watch Video Solution](#)

71. A point object is placed at a distance of 15 cm from a convex lens. The image is formed on the other side at a distance of 30 cm from the lens. When a concave lens is placed in contact with the convex lens, the image shifts away

further by 30 cm. Calculate the focal lengths of the two lenses.



[Watch Video Solution](#)

72. Two convex lenses each of focal length 10 cm, are placed at a separation of 15 cm with their principal axes coinciding. (a) Show that a light beam coming parallel to the principal axis diverges as it comes out of the lens system. (b) Find the location of the virtual image formed by the lens system of an object

placed far away. (c) Find the focal length of the equivalent lens.



[Watch Video Solution](#)

73. A ball is kept at a height h above the surface of a heavy transparent sphere made of a material of refractive index μ . The radius of the sphere is R . At $t = 0$, the ball is dropped to fall normally on the sphere. Find the speed of the image formed as a function of time for

$t < \sqrt{\frac{2h}{g}}$. Consider only the image by a single refraction.



[Watch Video Solution](#)

74. A particle is moving at a constant speed V from a large distance towards a concave mirror of radius R along its principal axis. Find the speed of the image formed by the mirror as a function of the distance x of the particle from the mirror.



[Watch Video Solution](#)

75. A small block of mass m and a concave mirror of radius R fitted with a stand lie on a smooth horizontal table with a separation d between them. The mirror together with its stand has a mass m . The block is pushed at $t = 0$ towards the mirror so that it starts moving towards the mirror at a constant speed V and collides with it. The collision is perfectly elastic. Find the velocity of the image (a) at a time $t < \frac{d}{V}$, (b) at a time $t > \frac{d}{V}$.



Watch Video Solution

76. A gun of mass M fires a bullet of mass m with a horizontal speed V . The gun is fitted with a concave mirror of focal length f facing towards the receding bullet. Find the speed of separation of the bullet and the image just after the gun was fired.



[Watch Video Solution](#)

77. Consider the situation shown in figure. The elevator is going up with an acceleration of 2.00 ms^{-2} and the focal length of the mirror is 12.0 cm . All the surfaces are smooth and the pulley is light. The mass-pulley system is released from rest (with respect to the elevator) at $t=0$ when the distance of B from the mirror is 42.0 cm . Find the distance between the image of the block B and the mirror at $t=0.200 \text{ s}$. Take $g = 10 \text{ ms}^{-2}$



Watch Video Solution

