



PHYSICS

BOOKS - HC VERMA

PHOTOMETRY

Examples

1. Find the luminous flux of 10 W source of 600 nm. The relative luminosity at 600 nm is 0.6.



Watch Video Solution

Worked Out Examples

1. A source emits 12.0 J of light of wavelength 620 nm and 8.0 J of light of wavelength 580 nm per second. The relative luminosity at 620 nm is 25% and that at 580 nm is 80%. Find a. the total radiant flux, b. the total luminous flux and c. luminous efficiency.



[Watch Video Solution](#)

2. A circular area of radius 1.0 cm is placed at a distance of 2.0 m from a point source. The source emits light uniformly in all directions. The line joining the source to the centre of the area is normal to the area. It is found that 2.0×10^{-3} lumen of luminous flux is incident on the area. Calculate the total luminous flux emitted by the source and the luminous intensity of the source along the axis of the area.



[Watch Video Solution](#)

3. The overall luminous efficient of a 100 W electric lamp is 25 lumen W^{-1} . Assume that light is emitted by the lamp only in the forward half, and is uniformly distributed in all directions in this half. Calculate the luminous flux falling on a plane object of area 1cm^2 placed at a distance of 50 cm from the lamp and perpendicular to the line joining the lamp and the object.



[Watch Video Solution](#)

4. A point source emitting uniformly in all directions is placed above a table top at a distance of 0.50 m from it. The luminous flux of the source is 1570 lumen. Find the illuminance at a small surface area of the table to a. directly below the source and b. at a distance of 0.80 m from the source.



[Watch Video Solution](#)

Short Answer

1. The luminous intensity of a small plane source of light along the forward normal is 160 candela. Assume the source to be perfectly diffused, find the luminous flux emitted into a cone of solid angle 0.02 sr around a line making an angle of 60° with the forward normal.



Watch Video Solution

2. What is the luminous flux of a source emitting radio waves ?



[Watch Video Solution](#)

3. The luminous flux of a 1 W sodium vapour lamp is more than that of a 10 kW source of ultraviolet radiation. Comment.



[Watch Video Solution](#)

4. Light is incident normally on a small plane surface. If the surface is rotated by an angle of 30° about the incident light, does the illuminance of the surface increase, decrease or remain same? Does your answer change if the light did not fall normally on the surface?



[Watch Video Solution](#)

5. A bulb is hanging over a table. At which portion of the table is the illuminance

maximum '? If a plane mirror is placed above the bulb facing the table, will the illuminance on the table increase ?



[Watch Video Solution](#)

6. The sun is less bright at morning and evening as compared to at noon although its distance from the observer is almost the same.

Why ?



[Watch Video Solution](#)

7. Why is the luminous efficiency small for a filament bulb as compared to a mercury vapour lamp ?



[Watch Video Solution](#)

8. The yellow colour has a greater luminous efficiency as compared to the other colours. Can we increase the illuminating power of a white light source by putting a yellow plastic paper around this source ?



[Watch Video Solution](#)

Objective 1

1. The one parameter that determines that brightness of a light source sensed by an eye is

A. energy of light entering the eye per second

B. wavelength of the light

C. total radiant flux entering the eye

D. total luminous flux entering the eye

Answer: D



Watch Video Solution

2. Three light sources A, B, and C emit equal amount of radiant energy per unit time. The wavelength emitted by the three sources are 450 nm, 555 nm and 700 nm respectively. The brightness sensed by an eye for the sources are X_A , X_B and X_C respectively. Then

A. $X_A < X_B, X_C > X_B$

B. $X_A > X_B, X_B > X_C$

C. $X_B > X_A, X_B < X_C$

D. $X_B > X_A, X_C > X_B$

Answer: C



Watch Video Solution

3. As the wavelength is increased from violet to red, the luminosity

- A. continuously increases
- B. continuously decreases
- C. increases then decreases
- D. decreases then increases

Answer: C



Watch Video Solution

4. An electric bulb is hanging over a table at a height of 1 m above it. The illuminance on the table directly below the bulb is 40 lux. The

illuminance at a point on the table 1 m away from the first point will be about

A. 10 lux

B. 14 lux

C. 20 lux

D. 28 lux

Answer: B



Watch Video Solution

5. Light from a point source falls on a screen. If the separation between the source and the screen is increased by 1%, the illuminance will decrease (nearly) by

A. 0.5%

B. 1%

C. 2%

D. 4%

Answer: C



Watch Video Solution

6. A battery operated torch is adjusted to send an almost parallel beam of light. It produces an illuminance of 40 lux when the light falls on a wall 2 m away. The illuminance produced when it falls on a wall 4 m away is close to

A. 40 lux

B. 20 lux

C. 10 lux

D. 5 lux

Answer: A



Watch Video Solution

7. The intensity produced by a long cylindrical light source at a small distance r from the source is proportional to

A. $\frac{1}{r^2}$

B. $\frac{1}{r^3}$

C. $\frac{1}{r}$

D. none of these

Answer: C



Watch Video Solution

8. A photographic plate placed at a distance of 5 cm from a weak point source is exposed for 3 s. If the plate is kept at a distance of 10 cm from the source, the time needed for the same exposure is

A. 3s

B. 12s

C. 24s

D. 48s

Answer: B



Watch Video Solution

9. A photographic plate is directly in front of a small diffused source in the shape of a circular disc. It takes 12 s to get a good exposure. If the source is rotated by 60°

about one of its diameters, the time needed to get the same exposure will be

A. 6s

B. 12s

C. 24s

D. 48

Answer: C



Watch Video Solution

10. A point source of light moves in a straight line parallel to a plane table. Consider a small portion of the table directly below the line of movement of the source. The illuminance at this portion varies with its distance r from the source as

A. $I \propto \frac{1}{r}$

B. $I \propto \frac{1}{r^2}$

C. $I \propto \frac{1}{r^3}$

D. $I \propto \frac{1}{r^4}$

Answer: C



Watch Video Solution

11. Figure shows a glowing mercury tube. The intensities at point A, B and C are related as

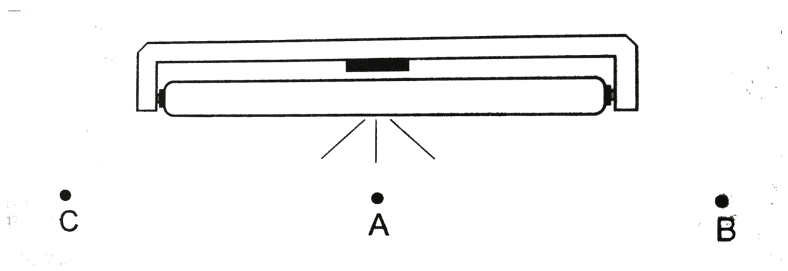

A. $B > C > A$

B. $A > C > B$

C. $B = C > A$

D. $B = C < A$

Answer: D



Watch Video Solution

Objective 2

1. The brightness producing capacity of a source

A. does not depend on its power

B. does not depend on the wavelength
emitted

C. depends on its power

D. depends on the wavelength emitted

Answer: C::D



Watch Video Solution

2. A room illuminated by an extended source.

The illuminance at a particular portion of a wall

can be increased by

A. moving the source

B. rotating the source

C. bringing some mirrors in proper
positions

D. changing the colour of the source

Answer: A::B::C::D





3. Mark the correct options

A. The luminous efficiency of a monochromatic source is always greater than that of a white light source of same power.

B. the luminous efficiency of a monochromatic source of wavelength

555 nm is always greater than that of a white light source of same power.

C. The illuminating power of a monochromatic source of wavelength 555 nm is always greater than that of a white light source of same power.

D. the illuminating power of a monochromatic source is always greater than that of a white light source of same power.

Answer: B::C



Watch Video Solution

4. Mark out the correct options

A. Luminous flux and radian flux have same dimensions

B. Luminous flux and luminous intensity have same dimensions

C. Radiant flux and power have same dimensions

D. Relative luminosity is a dimensionless quantity.

Answer: B::C::D



Watch Video Solution

Exercises

1. A source emits 45 joules of energy in 15 s.

What is the radiant flux of the source ?



Watch Video Solution

2. A photographic plate records sufficient intense lines when it is exposed for 12 s to a source of 10 W. How long should it be exposed to a 12 W source radiating the light of same colour to get equally intense lines ?



Watch Video Solution

3. Using figure (22.1), find the relative luminosity of wavelength (a) 480 nm, (b) 520 nm (c) 580 nm and (d) 600 nm.



[Watch Video Solution](#)

4. The relative luminosity of wavelength 600 nm is 0.6. Find the radiant flux of 600 nm needed to produce the same brightness sensation as produced by 120 W of radiant flux at 555 nm.



[Watch Video Solution](#)

5. The luminous flux of a monochromatic source of 1 W is 450 lumen / watt. Find the relative luminosity at the wavelength emitted.



[Watch Video Solution](#)

6. A source emits light of wavelengths 555 nm and 600 nm. The radiant flux of the 555 nm part is 40 W and of the 600 nm part is 30 W.

The relative luminosity at 600 nm is 0.6. Find (a) the total radiant flux, (b) the total luminous flux, (c) the luminous efficiency.



[Watch Video Solution](#)

7. A light source emits monochromatic light of wavelength 555 nm. The source consumes 100 W of electric power and emits 35 W of radiant flux. Calculate the overall luminous efficiency.



[Watch Video Solution](#)

8. A source emits 31.4 W of radiant flux distributed uniformly in all directions. The luminous efficiency is 60 lumen watt . What is the luminous intensity of the source ?



[Watch Video Solution](#)

9. A point source emitting 628 lumen of luminous flux uniformly in all directions is placed at the origin. Calculate the illuminance on a small area placed at $(1.0 \text{ m}, 0, 0)$ in such a

way that the normal to the area makes an angle of 37° with the X-axis.



[Watch Video Solution](#)

10. The illuminance of a small area changes from 900 lumen m^{-2} to 400 lumen m^{-2} when it is shifted along its normal by 10 cm. Assuming that it is illuminated by a point source placed on the normal, find the distance between the source and the area in the original position.



[Watch Video Solution](#)

11. A point source emitting light uniformly in all directions is placed 60 cm above a table-top. The illuminance at a point on the table-top, directly below the source, is 15 lux. Find the illuminance at a point on the table-top 80 cm away from the first point.



[Watch Video Solution](#)

12. Light from a point source falls on a small area placed perpendicular to the incident light. If the area is rotated about the incident light by an angle of $\sim 60^\circ$, by what fraction will the illuminance change?



Watch Video Solution

13. A student is studying a book placed near the edge of a circular table of radius R . A point source of light is suspended directly above the

centre of the table. What should be the height of the source above the table so as to produce maximum illuminance at the position of the book ?



[Watch Video Solution](#)

14. Figure shows a small diffused plane source S placed over a horizontal table-top at a distance of 2.4 m with its plane parallel to the table-top. The illuminance at the point A directly below the source is 25 lux. Find the

illuminance at a point B of the table at a distance of 1.8 m from A.

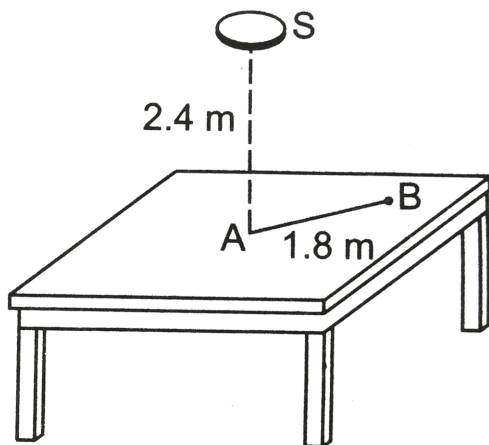

Watch Video Solution

15. An electric lamp and a candle produce equal illuminance at a photometer screen when they are placed at 80 cm and 20 cm from

the screen respectively. The lamp is now covered with a thin paper which transmits 49% of the luminous flux. By what distance should the lamp be moved to balance the intensities at the screen again ?



[Watch Video Solution](#)

16. Two light sources of intensities 8 cd and 12 cd are placed on the same side of a photometer screen at a distance of 40 cm

from it. Where should a 80 cd source be placed to balance the illuminance ?



Watch Video Solution