



## PHYSICS

### BOOKS - HC VERMA

# THERMAL AND CHEMICAL EFFECT OF ELECTRIC CURRENT

#### Examples

1. Find the heat developed in each of the three resistors shown in figure in 1 minute.

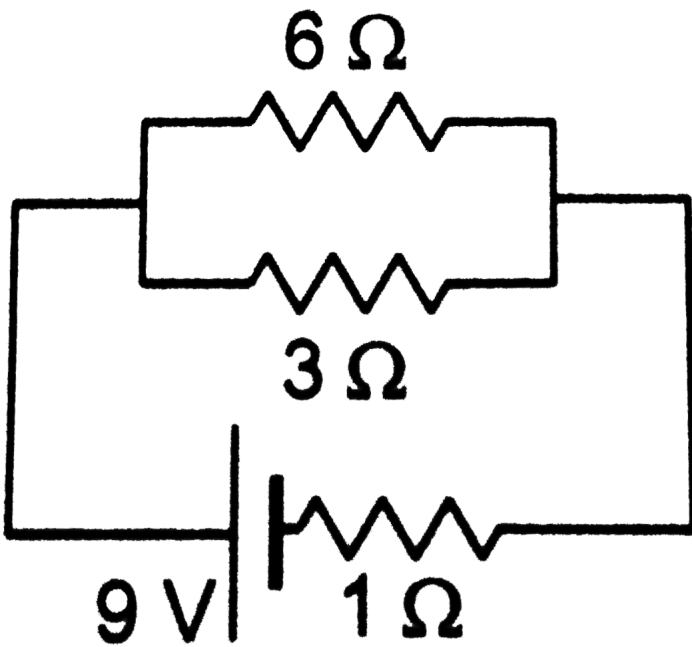

[▶ Watch Video Solution](#)

2. Calculate the electric current required to deposit 0.972g of chromium in three hours. ECE of chromium is  $0.00018gC^{-1}$

[▶ Watch Video Solution](#)

## Worked Out Examples

1. A current of  $30A$  is registered when the terminals of a dry cell of  $emf 1.5V$  are connected through an ammeter. Neglecting the meter resistance, find the amount of heat produced in the battery in 10 seconds.



[Watch Video Solution](#)

2. A room heater is rated  $500W, 220V$ . (a) Find the resistance of its coil. (b) If the supply voltage drops to  $200V$ , what will be the power consumed? (c) If an electric bulb rated  $100W, 220V$  is connected in series with this heater, what will be the power consumed by the heater and by the bulb when the supply is at  $220V$ ?



[Watch Video Solution](#)

3. A battery of e.m.f.  $E$  and internal resistance  $r$  is used in a circuit with a variable external resistance  $R$ . find the value of  $R$  for which the power consumed in  $R$  is maximum.



[Watch Video Solution](#)

4. The junctions of a  $Ni - Cu$  thermocouple are maintained at  $0^\circ C$  and  $100^\circ C$ . Calculate the Seebeck emf produced in the loop.  $a_{Ni,Cu} = 16.3 \times 10^{-6} V^\circ C^{-1}$  and  $b_{Ni,Cu} = -0.042 \times 10^{-6} V^\circ C^{-3}$



[Watch Video Solution](#)

5. Find the neutral and inversion temperatures for  $Ni - Cu$  thermocouple with the cold junction at  $0^\circ C$ . Use data from previous example.

 [Watch Video Solution](#)

6. An electric current of  $0.4A$  is passed through a silver voltmeter for half an hour. Find the amount of silver deposited on the cathode.  $ECE$  of silver  $= 1.12 \times 10^{-4} kgC^{-1}$

 [Watch Video Solution](#)

7. A silver and a copper voltmeter are connected in series with a  $12.0V$  battery of negligible resistance. It is found that  $0.806g$  of silver is deposited in half an hour. Find (a) the mass of the copper deposited and (b) the energy supplied by the battery.  $ECE$  of silver  $= 1.12 \times 10^{-6} kgC^{-1}$  and that of copper  $= 6.6 \times 10^{-7} kgC^{-1}$

 [Watch Video Solution](#)

8. A current of  $1A$  is passed through a dilute solution of sulphuric acid for some time to liberate  $1g$  of oxygen. How much hydrogen is liberated during this period? How long

was the current passed? Faraday constant

$$= 96500Cmol^{-1}.$$



Watch Video Solution

## Short Answer

1. If a constant potential difference is applied across a bulb, the current slightly decreases as time passes and then becomes constant. Explain.



Watch Video Solution

2. Two unequal resistances  $R_1$  and  $R_2$  are connected across two identical batteries of emf  $\varepsilon$  and internal

resistance  $r$  (figure). Can the thermal energies developed in  $R_1$  and  $R_2$  be equal in a given time. If yes, what will be the condition? (Figure Question)

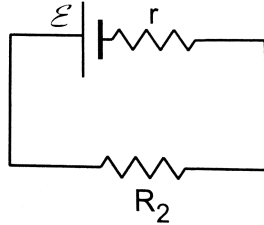
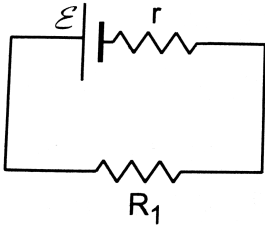

[▶ Watch Video Solution](#)

3. When a current passes through a resistor, its temperature increases. Is it an adiabatic process?

[▶ Watch Video Solution](#)



4. Apply the first law of thermodynamics to a resistor carrying a current  $i$ . Identify which of the quantities  $\Delta Q$ ,  $\Delta U$  and  $\Delta W$  are zero, which are positive and which are negative.

 [Watch Video Solution](#)

5. Do all the thermocouples have a neutral temperature?

 [Watch Video Solution](#)

6. Is inversion temperature always double of the neutral temperature? Does the unit of temperature have an effect in deciding this question?



[Watch Video Solution](#)

7. Is neutral temperature always the arithmetic mean of the inversion temperature and the temperature of the cold junction? Does the unit of temperature have an effect in deciding this question?



[Watch Video Solution](#)

8. Do the electrodes in an electrolytic cell have fixed polarity like a battery?



[Watch Video Solution](#)

9. As temperature increases, the viscosity of liquids decrease considerably. Will this decrease the resistance of an electrolyte as the temperature increases?

 [Watch Video Solution](#)

## Objective 1

1. Which of the following plots may represent the thermal energy produced in a resistor in a given time as a

function of the electric current? Figure

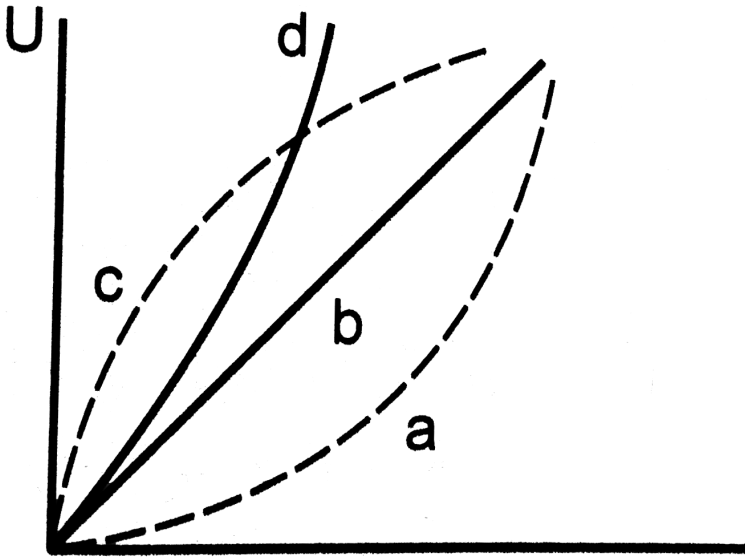

[Watch Video Solution](#)

2. A constant current  $i$  is passed through a resistor. Taking the temperature coefficient of resistance into account, indicate which of the plots shown in Figure best represents the rate of production of thermal energy in

the resistor

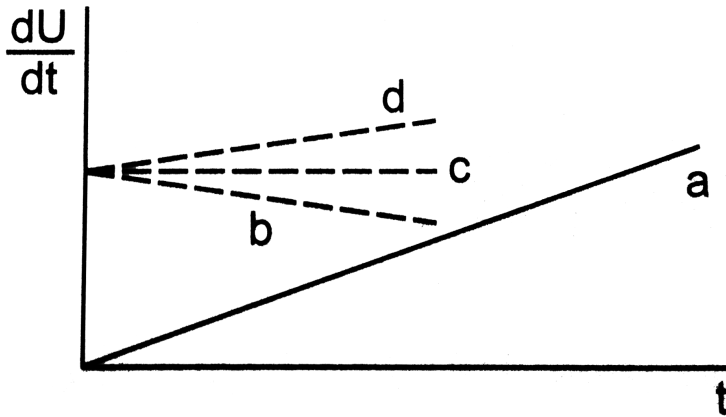

 [Watch Video Solution](#)

3. Consider the following statements regarding a thermocouple. (A) The neutral temperature does not depend on the temperature of the cold junction. (B) The inversion temperature does not depend on the temperature of the cold junction.

- A. Both A and B are correct.
- B. A is correct but B is wrong
- C. B is correct but A is wrong
- D. Both A and B are wrong

**Answer: B**



**Watch Video Solution**

4. The heat developed in a system is proportional to the current through it.

- A. It cannot be Thomson heat.
- B. It cannot be Peltier heat.

C. It cannot be Joule heat.

D. It can be any of the three heats mentioned above.

**Answer: C**

 [Watch Video Solution](#)

5. Consider the following two statements (A) Free-electron density is different in different metals. (B) Free-electron density in a metal depends on temperature.

Seebeck effect is caused

A. due to both A and B

B. due to A but not due to B

C. due to B but not due to A

D. neither due to A nor due to B

**Answer: A**

 [Watch Video Solution](#)

6. Consider the statements A and B in the previous question. Peltier effect is caused

A. due to both A and B

B. due to A but not due to B

C. due to B but not due to A

D. neither due to A nor due to B

**Answer: B**





[Watch Video Solution](#)

7. Consider the statement A and B in question 5. Thomson effect is caused

- A. due to both A and B
- B. due to A but not due to B
- C. due to B but not due to A
- D. neither due to A nor due to B

**Answer: C**



[Watch Video Solution](#)

## 8. Faraday constant

- A. depends on the amount of the electrolyte
- B. depends on the current in the electrolyte
- C. is a universal constant
- D. depends on the amount of charge passed through the electrolyte

**Answer:**



**Watch Video Solution**

**Objective 2**

1. Two resistors having equal resistances are joined in series and a current is passed through the combinations. Neglect any variation in resistance as the temperature changes. In a given time interval:-

A. equal amounts of thermal energy must be produced in the resistors

B. unequal amount of thermal energy may be produced

C. the temperature must rise equally in the resistors

D. the temperature may rise equally in the resistors.

**Answer: A:D**



**Watch Video Solution**

2. A copper strip  $AB$  and an iron strip  $AC$  are joined at  $A$ . The junction  $A$  is maintained at  $0^\circ C$  and the free ends  $B$  and  $C$  are maintained at  $100^\circ C$ . There is a potential difference between

- A. the two ends of the copper strip
- B. the copper end and the iron end at the junction
- C. the two ends of the iron strip
- D. the free ends  $B$  and  $C$ .

**Answer: A::B::C::D**



**Watch Video Solution**

3. The constants  $a$  and  $b$  for the pair silver-lead are  $2.50\mu V^{\circ}C^{-1}$  and  $0.012\mu V^{\circ}C^{-2}$  respectively. For a silver-lead thermocouple with colder junction at  $0^{\circ}C$ ,

A. there will be no neutral temperature

B. there will be no inversion temperature

C. there will not be any thermo-emf even if the junctions are kept at different temperatures

D. there will be no current in the thermocouple even if the junctions are kept at different temperature.

**Answer: A::B**



**Watch Video Solution**

4. An electrolysis experiment is stopped and the battery terminals are reversed.

A. The electrolysis will stop

B. The rate of liberation of material at the electrodes will increase.

C. The rate of liberation of material will remain the same.

D. Heat will be produced at a greater rate.

**Answer: C**



**Watch Video Solution**

5. The electrochemical equivalent of a material depends on

A. the nature of the material

B. the current through the electrolyte containing the material

C. the amount of charge passed through the electrolyte

D. the amount of this material present in the electrolyte.

**Answer: A**



**Watch Video Solution**

## Exercises

1. An electric current of  $2.0\text{ A}$  passes through a wire of resistance  $25\Omega$ . How much heat will be developed in 1 minute?



[Watch Video Solution](#)

2. A coil of resistance  $100\Omega$  is connected across a battery of  $emf\ 6.0\text{V}$ . Assume that the heat developed in the coil is used to raise its temperature. If the heat capacity of the coil is  $4.0\text{JK}^{-1}$ , how long will it take to raise the temperature of the coil by  $15^\circ\text{C}$ ?



[Watch Video Solution](#)



3. The specification on a heater coil is  $250V, 500W$ . Calculate the resistance of the coil. What will be the resistance of a coil of  $1000W$  to operate at the same voltage?



[Watch Video Solution](#)

4. A heater coil is to be constructed with a nichrome wire ( $\rho = 1.0 \times 10^{-6} \Omega m$ ) which can operate at  $500W$  when connected to a  $250V$  supply. (a) What would be the resistance of the coil? (b) If the cross-sectional area of the wire is  $0.5mm^2$ , what length of the wire will be needed? (c) If the radius of each turn is  $4.0mm$ , how many turns will be there in the coil?



[Watch Video Solution](#)

5. A bulb with rating  $250V$ ,  $100W$  is connected to a power supply of  $220V$  situated  $10m$  away using a copper wire of area of cross section  $5mm^2$ . How much power will be consumed by the connecting wire? Resistivity of copper  $= 1.7 \times 10^{-8}\Omega m$ .



[Watch Video Solution](#)

6. An electric bulb, when connected across a power supply of  $220V$ , consumes a power of  $60W$ . If the supply drops to  $180V$ , what will be the power consumed? If supply is

suddenly increased to  $240V$ , what will be the power consumed?

 [Watch Video Solution](#)

7. A servo voltage stabiliser restricts the voltage output to  $220V \pm 1\%$ . If an electric bulb rated at  $220V, 100W$  is connected to it, what will be the minimum and maximum power consumed by it?

 [Watch Video Solution](#)

8. An electric bulb marked  $220V, 100W$  will get fused if it is made to consume  $150W$  or more. What voltage fluctuation will the bulb withstand?



[Watch Video Solution](#)

9. An immersion heater rated  $1000W$ ,  $220V$  is used to heat  $0.01m^3$  of water. Assuming that the power is supplied at  $220V$  and  $60\%$  of the power supplied is used to heat the water, how long will it take to increase the temperature of the water from  $15^\circ C$  to  $40^\circ C$  ?



[Watch Video Solution](#)

10. An electric kettle used to prepare tea, takes 2 minutes to boil 4 cups of water (1 cup contains 200 cc of water) if the room temperature is  $25^\circ C$ , (a) If the cost of power consumption is  $Rs1.00$  per unit

(1 unit = 1000 wa - hour), calculate the cost of boiling 4 cups of water. (b) What will be the corresponding cost if the room temperature drops to  $5^{\circ} C$ ?

 [Watch Video Solution](#)

**11.** The coil of an electric bulb takes 40 watts to start glowing. If more than 40 W is supplied, 60% of the extra power is converted into light and the remaining into heat. The bulb consumes 100 W at 220 V. Find the percentage drop in the light intensity at a point if the supply voltage changes from  $220V \rightarrow 200V$ .

 [Watch Video Solution](#)

12. The  $2.0\Omega$  resistor shown in figure is dipped into a calorimeter containing water. The heat capacity of the calorimeter together with water is  $2000JK^{-1}$ . (a) If the circuit is active for 15 minutes, what would be the rise in the temperature of the water? (b) Suppose the  $6.0\Omega$  resistor gets burnt. What would be the rise in the temperature of the water in the next 15 minutes? (Figure)

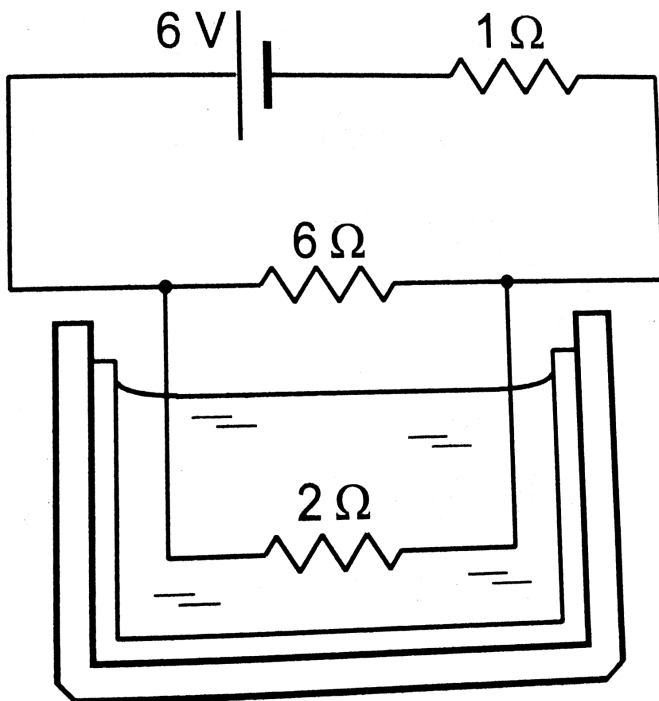



Watch Video Solution

**13.** The temperatures of the junctions of a bismuth-silver thermocouple are maintained at  $0^\circ C$  and  $0.001^\circ C$ . Find the thermo-emf (Seebeck emf) developed. For bismuth-silver,

$$a = -46 \times 10^{-6} V^\circ C^{-1} \text{ and } b = -0.48 \times 10^{-6} V^\circ C^{-2}$$

.



Watch Video Solution

**14.** Find the thermo-emf developed in a copper-silver thermocouple when the junctions are kept at  $0^\circ C$  and  $40^\circ C$ . Use the data in table.

 [Watch Video Solution](#)

15. Find the neutral temperature and inversion temperature of copper-iron thermocouple if the reference junction is kept at  $0^{\circ}C$ . Use the data in table.

 [Watch Video Solution](#)

16. Find the charge required to flow through an electrolyte to liberate one atom of (a) a monovalent material and (b) a divalent material.

 [Watch Video Solution](#)



17. Find the amount of silver liberated at cathode if  $0.500A$  of current is passed through  $AgNO_3$  electrolyte for 1 hour. Atomic weight of silver is  $107.9gmol^{-1}$

 [Watch Video Solution](#)

18. An electroplating unit plates  $3.0g$  of silver on a brass plate in  $3.0$  minutes. Find the current used by the unit. The electrochemical equivalent of silver is  $1.12 \times 10^{-6}kgC^{-1}$ .

 [Watch Video Solution](#)

19. Find the time required to liberate 1.0 litre of hydrogen at STP in an electrolytic cell by a current of 5.0A.

 [Watch Video Solution](#)

20. Two voltameters, one having a solution of silver salt and the other of a trivalent-metal salt, are connected in series and a current of 2A is maintained for 1.50hours. It is found that 1.00g of the trivalent metal is deposited. (a) What is the atomic weight of the trivalent metal? (b) How much silver is deposited during this period?

Atomic weight of silver is  $109.9\text{g mol}^{-1}$

 [Watch Video Solution](#)

**21.** A brass plate having surface area  $200\text{cm}^2$  on one side is electroplated with  $0.10\text{mm}$  thick silver layers on both sides using a  $15\text{A}$  current. Find the time taken to do the job. The specific gravity of silver is  $10.5$  and its atomic weight is  $107.9\text{gmol}^{-1}$



**Watch Video Solution**

**22.** Figure, shows an electrolyte of  $\text{AgCl}$  through which a current is passed. It is observed that  $2.68\text{g}$  of silver is deposited in 10 minutes on the cathode. Find the heat developed in the  $20\Omega$  resistor during this period. Atomic

weight of silver is  $107.9 \text{ g mol}^{-1}$ . (Figure)

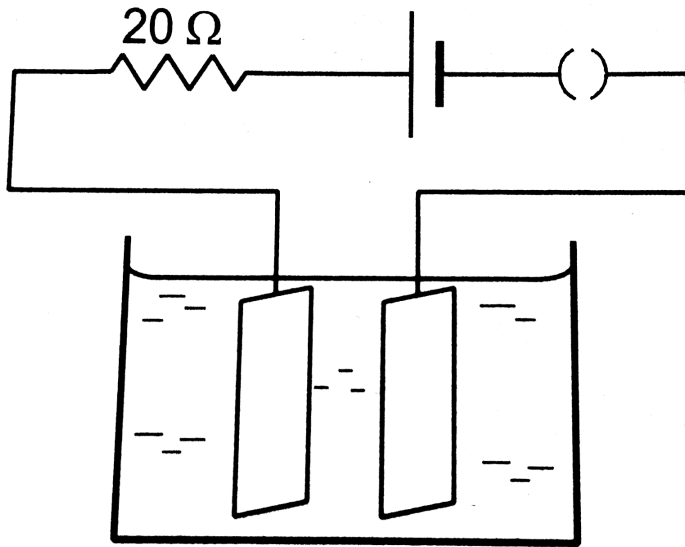

[▶ Watch Video Solution](#)

23. The potential difference across the terminals of a battery of  $emf 12V$  and internal resistance  $2\Omega$  drops to  $10V$  when it is connected to a silver voltameter. Find the silver deposited at the cathode in half an hour. Atomic weight of silver is  $107.9 \text{ g mol}^{-1}$ .



Watch Video Solution

24. A plate of area  $10\text{cm}^2$  is to be electroplated with copper (density  $9000\text{kgm}^{-3}$  to a thickness of 10 micrometres on both sides, using a cell of  $12\text{V}$ . Calculate the energy spend by the cell in the process of deposition. If this energy is used to heat  $100\text{g}$  of water, calculate the rise in the temperature of the water. ECE of copper  $= 3 \times 10^{-7}\text{kgC}^{-1}$  and specific heat capacity of water  $= 4200\text{Jkg}^{-1}\text{K}^{-1}$ .



Watch Video Solution