



CHEMISTRY

BOOKS - VK JAISWAL ENGLISH

p-BLOCK ELEMENTS

Level 1

1. Anhydrous aluminium chloride (Al_2Cl_6) is covalent compound and soluble in water giving:

A. Al^{3+} and Cl^- ions.

B. $[Cl(H_2O)_6]^{3+}$ and Cl^- ions

C. $[AlCl_2(H_2O)_4]$ and $[AlCl_4(H_2O)_2]^-$ ions

D. none of the above

Answer: C



Watch Video Solution

2. Al_4C_3 is a ionic carbide, named as:

- A. Acetylide
- B. Methanide
- C. Allylide
- D. Alloy

Answer: B



Watch Video Solution

3. On the addition of mineral acid to an aqueous solution of borax, the compound formed is:

- A. Boron oxide
- B. Orthoboric acid

C. Metaboric acid

D. Pyroboric acid

Answer: B

 [Watch Video Solution](#)

4. $AlCl_3$ on hydrolysis gives

A. $Al_2O_3 \cdot H_2O$

B. $Al(OH)_3$

C. Al_2O_3

D. $AlCl_3 \cdot 6H_2O$

Answer: B

 [Watch Video Solution](#)

5. Alumina is insoluble in water because:

- A. It is a covalent compound
- B. It has high lattice energy and low heat of hydration
- C. It has low lattice energy and high heat of hydration
- D. Al^{3+} and O^{2-} ions are not excessively hydrated

Answer: B



[Watch Video Solution](#)

6. Which of the following is an electron deficient molecule?

- A. LiH
- B. B_2H_6
- C. $LiBH_4$
- D. $B_3N_3H_6$

Answer: B



[Watch Video Solution](#)

7. Anhydrous aluminium chloride fumes in moist air owing to the formation of:

- A. Gaseous aluminium chloride
- B. chlorine
- C. chlorine dioxide
- D. hydrogen chloride

Answer: D



[Watch Video Solution](#)

8. Colour of the bead in borax bead test mainly due to the formation of

- A. metal oxides
- B. boron oxide
- C. metal metaborates
- D. elemental boron

Answer: C

 [Watch Video Solution](#)

9. The possible oxidation states of Tl are:

- A. +1 and +2
- B. +2 and +3
- C. +1 and -1
- D. +1 and +3

Answer: D

 [Watch Video Solution](#)

10. Which of the following sublimes on heating ?

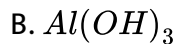
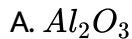

Answer: D



Watch Video Solution

11. The gaseous product(s) expected at room temperature by reaction of sodium borohydride and boron trifluoride under anhydrous conditions is/are:

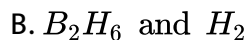

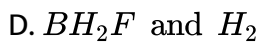
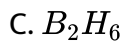

Answer: C

 [Watch Video Solution](#)

12. Silicate having one monovalent corner oxygen atom in each tetrahedron unit is

A. sheet silicate

B. cyclic silicate

C. single chain silicate

D. double chain silicate

Answer: A

 [Watch Video Solution](#)

13. PbI_4 does not exist because:

- A. iodine is not a reactive
- B. $Pb(IV)$ is oxidizing and I^- is strong reducing agent
- C. $Pb(IV)$ is less stable than $Pb(II)$
- D. Pb^{4+} is not easily formed

Answer: B



[Watch Video Solution](#)

14. The silicate anion in the mineral kinoite is a chain of three SiO_4 tetrahedra, that share corners with adjacent tetrahedra. The charge of silicate anion is

- A. -4
- B. -8
- C. -6

D. - 2

Answer: B



[Watch Video Solution](#)

15. The gaseous product of the reaction between Sn and conc. H_2SO_4 is:

A. H_2

B. SO_2

C. SnH_4

D. SO_3

Answer: B



[Watch Video Solution](#)

16. The dehydration of malonic acid $CH_2(COOH)_2$ with P_4O_{10} and heat give

- A. carbon monoxide
- B. carbon suboxide
- C. carbon dioxide
- D. all three

Answer: B



[Watch Video Solution](#)

17. Which of the following structural features of graphite best accounts for its use as a lubricant?

- A. Delocalized electrons
- B. Strong covalent bonds between carbons atoms
- C. van der waals' forces between layers

D. limited three covalency of carbon

Answer: C

 [Watch Video Solution](#)

18. Which of the following is sparingly soluble in cold water and fairly soluble in hot water?

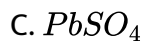
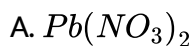

Answer: B

 [Watch Video Solution](#)

19. The structural of silicon(IV) oxide belongs to the type:

- A. ionic lattice
- B. macromolecular with a layer structure
- C. molecular lattice, with van der Waals' forces among the molecules
- D. macromolecular, with a non-layer structure

Answer: D



Watch Video Solution

20. Silicon dissolves in excess of HF due to formation of

- A. SiF_4
- B. SiH_4
- C. H_2SiF_6
- D. H_2SiF_4

Answer: C



Watch Video Solution

21. Which of the following halides does not hydrolyse at room temperature?

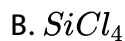

Answer: C



Watch Video Solution

22. $SiCl_4$ on hydrolysis gives:

- A. silica
- B. silicic acid
- C. silicone
- D. silicate

Answer: B

 [Watch Video Solution](#)

23. Which substance is having molecular solid:

- A. graphite
- B. C_{60}
- C. gold
- D. $Ca_3(PO_4)_2$

Answer: B

 [Watch Video Solution](#)

24. Identify the cyclic silicate ion given in the figure below

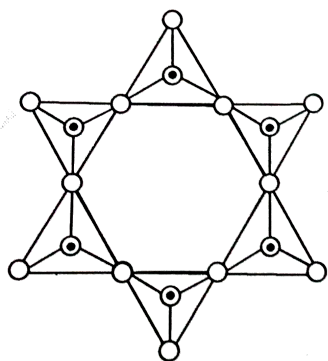

where

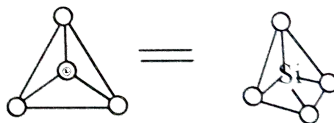

• = Si

○ = O

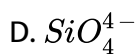
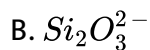
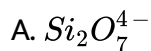

Answer: C

 Watch Video Solution

25. Which of the following is an organo silicon polymer?

- A. Silica
- B. Silicone
- C. Silicon carbide
- D. Silicic acid

Answer: B

 [Watch Video Solution](#)

26. SnCl_2 acts as a reducing agent because

- A. SnCl_2 can accept electrons readily
- B. Sn^{2+} is more stable than Sn^{4+}
- C. Sn^{4+} is more stable than Sn^{2+}
- D. Sn^{2+} can be easily converted to metallic tin

Answer: C

 [Watch Video Solution](#)

27. The correct order of decreasing ionic nature of lead dihalides is:

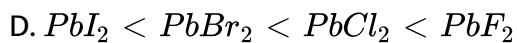
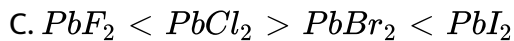
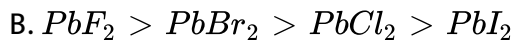
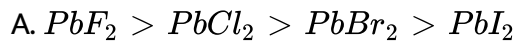

Answer: A



[Watch Video Solution](#)

28. What is carborundum ?

A. molecular solid

B. covalent solid

C. ionic solid

D. amorphous solid

Answer: B



[Watch Video Solution](#)

29. The tin plague or tin pest or tin disease refers to

- A. conversion of stannous to stannic
- B. conversion of white tin to grey tin
- C. emission of sound while bending a tin rod
- D. atmospheric oxidation of tin

Answer: B



[Watch Video Solution](#)

30. Butter of tin is

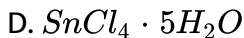
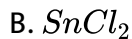
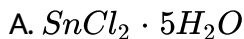

Answer: D

 Watch Video Solution

31. $\text{H}_2\text{C}_2\text{O}_4 \xrightarrow{\Delta} \text{gas}(A) + \text{gas}(B) + \text{liquid}(C)$. Gas(A) burns with a blue flame and is oxidised to gas(B).

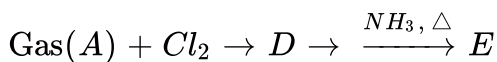

A,B,C,D and E are

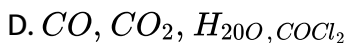

Answer: C

 [Watch Video Solution](#)

32. $Si_2O_7^{6-}$ anion is obtained when:

- A. no oxygen of a SiO_4 tetrahedron is shared with another SiO_4 tetrahedron
- B. one oxygen of a SiO_4 tetrahedron is shared with another SiO_4 tetrahedron
- C. two oxygen of a SiO_4 tetrahedron are shared with another SiO_4 tetrahedron
- D. three or all four oxygen of oxygen of a tetrahedron are shared with other SiO_4 tetrahedron

Answer: B

 [Watch Video Solution](#)

33. Trisilylamine ($(SiH_3)_3 N$) is

- A. trigonal pyramidal and acidic
- B. trigonal pyramidal and basic
- C. trigonal pyramidal and neutral
- D. trigonal planar and weakly basic

Answer: D



Watch Video Solution

34. The mixed anhydride of nitrogen is:

- A. $N_2O_2(2NO)$
- B. $N_2O_4(2NO_2)$
- C. N_2O_5
- D. N_2O_3

Answer: B

 [Watch Video Solution](#)

35. Among NH_3 , PH_3 , AsH_3 and SbH_3 which one is a stronger reducing agent?

A. NH_3

B. PH_3

C. AsH_3

D. SbH_3

Answer: D

 [Watch Video Solution](#)

36. When zinc reacts with very dilute HNO_3 , the oxidation state of nitrogen changes from:

A. +5 to +1

B. +5 to -3

C. +5 to +4

D. +5 to +3

Answer: B

 [Watch Video Solution](#)

37. The correct order of thermal stability of hydrides of group 15 is

A. $NH_3 > PH_3 > AsH_3$

B. $NH_3 < PH_3 < AsH_3$

C. $NH_3 > PH_3 < AsH_3$

D. $NH_3 < PH_3 > AsH_3$

Answer: A

 [Watch Video Solution](#)

38. The products formed by complete hydrolysis of PCl_3 are:

A. H_3PO_3 and HCl

B. $POCl_3$ and HCl

C. H_3PO_4 and HCl

D. $H_4P_2O_7$ and HCl

Answer: A



[Watch Video Solution](#)

39. When a sample of NO_2 is placed in a container, this equilibrium is rapidly established.

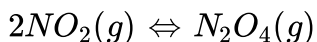

If this equilibrium mixture is a darker colour at high temperatures and at low pressure, which of these statements about the reaction is true?

- A. The reaction is exothermic and NO_2 is darker in colour than N_2O_4
- B. The reaction is exothermic and N_2O_4 is darker in colour than NO_2
- C. The reaction is endothermic and NO_2 is darker in colour than N_2O_4
- D. The reaction is endothermic and N_2O_4 is darker in colour than NO_2

Answer: A

 [Watch Video Solution](#)

40. Thermal decomposition of ammonium dichromate produces gas and steam.

- A. NH_3 , Cr_2O_3 and H_2O
- B. N_2 , Cr_2O_3 and H_2O
- C. NO , CrO_3 and H_2O

D. N_2O , CrO_3 and H_2O

Answer: B



[Watch Video Solution](#)

41. Which of the following halide undergoes in hydrolysis via S_{N1} reaction?

A. BCl_3

B. NF_3

C. NCl_3

D. $AsCl_3$

Answer: B



[Watch Video Solution](#)

42. Which of the following compound does not give oxyacid of central atom on hydrolysis?

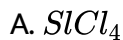

Answer: B



Watch Video Solution

43. In which process does the nitrogen undergo oxidation?

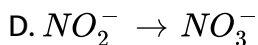
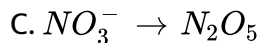
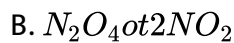
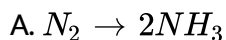

Answer: D



Watch Video Solution

44. For which element would XH_3 be a stable species:

A. C

B. Si

C. P

D. S

Answer: C



Watch Video Solution

45. The bond length of the S-O bond is maximum in which of the following compounds?

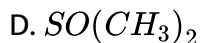
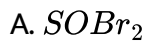

Answer: D

 [Watch Video Solution](#)

46. In case of hydride of oxyge family, which of the following physical property change regularly on moving down the group

A. Melting point

B. Thermal stability

C. Boiling point

D. Critical temperature

Answer: B

 [Watch Video Solution](#)

47. When $KHSO_4$ is added into a concentrated solution of H_2SO_4 the acidity of the solution.

- A. Increases
- B. decreases
- C. remains constant
- D. can't be predicted

Answer: B

 [Watch Video Solution](#)

48. Hydrolysis of one mole of peroxodisulphuric acid produces

- A. two moles of sulphuric acid
- B. two moles of peroxomono-sulphuric acid

- C. one mole of sulphuric acid, one mole of peroxomono-sulphuric acid
- D. one mole of sulphuric acid, one mole of peroxomono-sulphuric acid
and one mole of hydrogen peroxide

Answer: C

 [Watch Video Solution](#)

49. In trimer form of sulphur trioxide, each sulphur atom is bonded with:

- A. four oxygen atoms
- B. three oxygen atoms
- C. two oxygen atoms
- D. two sulphur atoms

Answer: A

 [Watch Video Solution](#)

50. Sodium thiosulphate is formed when:

- A. SO_2 is boiled into Na_2S
- B. Na_2SO_3 is boiled withh elemental sulphur
- C. $H_2S_2O_3$ is neutralised by NaOH
- D. Na_2SO_4 is reduced by zinc dust

Answer: B::C

 [Watch Video Solution](#)

51. $K_4[Fe(CN)_6]$ reacts with ozone is give:

- A. Fe_2O_3
- B. $Fe(OH)_2$
- C. $K_3[Fe(CN)_6]$
- D. KNO_3

Answer: C

 [Watch Video Solution](#)

52. The dipole moment of H_2O_2 is more than that of H_2O but H_2O_2 is not a good solvent because :

- A. It has a very high dielectric constant so that ionic compounds cannot be dissolved in it
- B. It does not act as an oxidising agent
- C. It acts as a reducing agent
- D. It dissociates easily and acts as an oxidising agent in chemical reactions

Answer: D

 [Watch Video Solution](#)

53. The correct increasing order of acidity is:

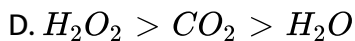
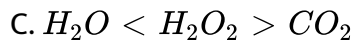
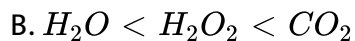
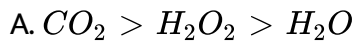

Answer: B

 [Watch Video Solution](#)

54. In which cases, the order of acidic strength is not correct ?

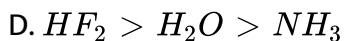

Answer: B



Watch Video Solution

55. Concentrated HNO_3 reacts with iodine to give:

A. HIO

B. HI

C. HIO_2

D. HIO_3

Answer: D



Watch Video Solution

56. Thermally most stable compound is:

A. $HOClO_3$

B. $HOClO_2$

C. $HOCl$

D. HOClO

Answer: A



Watch Video Solution

57. Which of the following halogen oxide is used for estimation of carbon monoxide in automobile exhaust gases?

A. Cl_2O_7

B. I_2O_5

C. ClO_2

D. BrO_3

Answer: B



Watch Video Solution

58. The interhalogen which does not exist is:

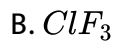

Answer: D



Watch Video Solution

59. Which of the following halogen disproportionates in water?



D. all three

Answer: B

 [Watch Video Solution](#)

60. Which of the following is correct statement?

- A. F_2 has higher dissociation energy than Cl_2
- B. F has higher electron affinity than Cl
- C. HF is stronger acid than HCl
- D. Boiling point increases down the group in halogens

Answer: D

 [Watch Video Solution](#)

61. Only iodine forms hepta-fluoride IF_7 , but chlorine and bromine give penta-fluorides. The reason for this is:

A. low electron affinity of iodine

B. unusual pentagonal bipyramidal structure of IF_7

C. that the larger iodine atom can accommodate more number of smaller fluorine atoms around it

D. low chemical reactivity of IF_7

Answer: C

 [Watch Video Solution](#)

62. Acid used for making permanent markings on the glass surface is.

A. HNO_3

B. HF

C. HIO_3

D. H_2SO_4

Answer: D



Watch Video Solution

63. The unfavourable electrochemical reaction among the following is:

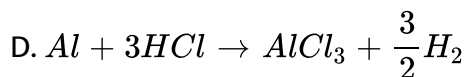
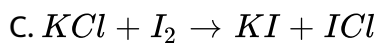
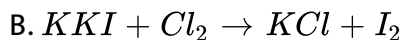
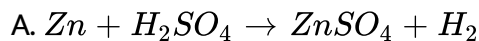

Answer: C



Watch Video Solution

64. Which anion can undergo both oxidation and reduction?

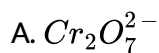

D. S^{2-}

Answer: C



[Watch Video Solution](#)

65. In the series HCl, HBr and HI, the boiling point increases in the order $HCl < HBr < HI$. This is due to:

- A. HI is the strongest acid among the series
- B. HI is the strongest reducing agent among the series
- C. higherr van der waals' forces of attraction in HI
- D. intermolecular H-bonding in HI

Answer: C



[Watch Video Solution](#)

66. Which factor is most responsible for the increase in boiling points of noble gases from He to Xe?

- A. Decrease in I.E.
- B. Monoatomic nature
- C. Decrease in polarisability
- D. Increase in polarisability

Answer: D



[Watch Video Solution](#)

67. The compound that cannot be formed by xenon is:

- A. XeO_3
- B. XeF_4
- C. $XeCl_4$
- D. XeO_2F_2

Answer: C

 [Watch Video Solution](#)

68. Noble gases can be separated by:

- A. passing them through suitable solution
- B. electrolysis of their fluorides
- C. adsorption and desorption on coconut charcoal
- D. adsorption and desorption on activated hydrogen

Answer: C

 [Watch Video Solution](#)

69. Which of the following xenon compound has the same number of lone pairs as in I_3^- ?

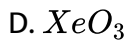
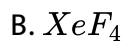
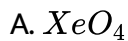

Answer: C

 [Watch Video Solution](#)

70. Incorrectly matched characteristic is:

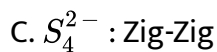

Answer: A

 [Watch Video Solution](#)

71. Which is wrong statement?

A. The decreasing order of thermal stability is

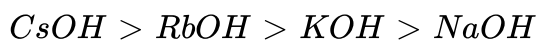

B. The decreasing order of bond angle is $BF_3 > PF_3 > ClF_3$

C. The decreasing order of bond dissociation energy is

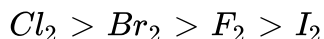

D. The decreasing order of melting point is

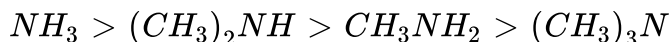

Answer: D



[Watch Video Solution](#)

72. Which of the following has been arranged in order of decreasing bond dissociation energy:

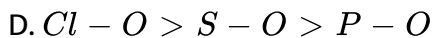
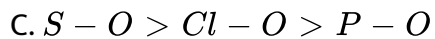
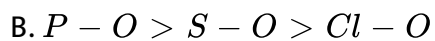
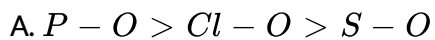

Answer: D

 Watch Video Solution

Level 2

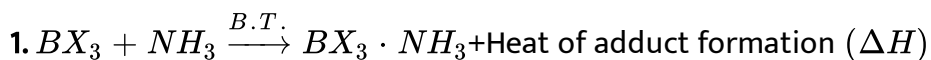

The numerical value of ΔH is found to be maximum for:

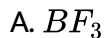

Answer: D

 [Watch Video Solution](#)

2. Which is the following properties describes the diagonal relationship boron and silicon?

- A. BCl_3 is not hydrolysed while $SiCl_4$ can be hydrolysed
- B. Both form oxides B_2O_3 is amphoteric and SiO_2 is acidic
- C. Both metals dissolve in cold and dilute nitric acid
- D. Silicide and boride salts are hydrolysed by water

Answer: D

 [Watch Video Solution](#)

3. Anhydrous $AlCl_3$ is covalent however, when it is dissolved in water hydrated ionic species are formed. This transformation is owing to:

- A. the trivalent state of Al
- B. the large hydration energy of Al^{3-}
- C. the low hydration energy of Al^{3+}
- D. the polar nature of water

Answer: B

 [Watch Video Solution](#)

4. Borax in its crystal possesses:

- A. 3 tetrahedral unit
- B. 2 tetrahedral and 2 planar triangular units
- C. 3 tetrahedral and 2 planar triangular units
- D. all tetrahedral units

Answer: B

 [Watch Video Solution](#)

5. The molecular shapes of diborane is shown below :

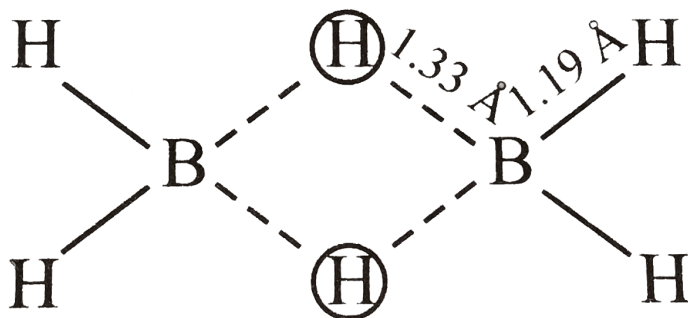

Consider the following statements for diborane :

- (i) Boron is approximately sp^3 hybridised.
- (ii) $B - H - B$ angle is 180°
- (iii) There are two terminal $B - H$ bonds for each boron atom.
- (iv) There are only 12 bonding electrons available of These statements :

A. 1,3 and 4 are correct

B. 1,2 and 3 are correct

C. 2,3 and 4 are correct

D. 1,2 and 4 are correct

Answer: A

 [Watch Video Solution](#)

6. Aluminium vessels should not be washed with materials containing washing soda because:

- A. washing soda reacts with aluminium to form soluble aluminate
- B. washing soda is expensive
- C. washing soda is easily decomposed
- D. washing soda reacts with aluminium to form insoluble aluminium oxide

Answer: A

 [Watch Video Solution](#)

7. Which of the following statements about anhydrous aluminium chloride is correct?

- A. It can exist as $AlCl_3$ molecule in vapour
- B. it is a strong Lewis base
- C. It sublimes at $180^\circ C$ under vacuum
- D. it is not easily hydrolysed

Answer: A::C



Watch Video Solution

8.

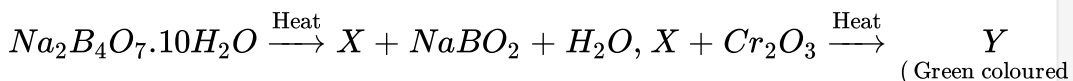

X and Y are :

- A. Na_3BO_{30} and $Cr(BO_2)_3$
- B. $Na_2B_4O_7$ and $Cr(BO_2)_3$

C. B_2O_3 and $Cr(BO_2)_3$

D. B_2O_3 and $CrBO_3$

Answer: C

 [Watch Video Solution](#)

9. Borax is converted into amorphous Boron by following steps

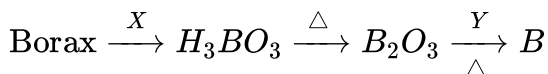

X and Y are respectively

A. HCl, Mg

B. HCl, C

C. C, Al

D. HCl, Al

Answer: D

 [Watch Video Solution](#)

10. The dissolution of $Al(OH)_3$ by a solution of $NaOH$ results in the formation of

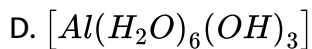
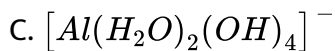
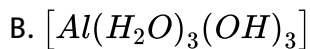
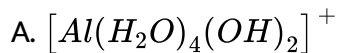

Answer: C



Watch Video Solution

11. Choose the correct sequence for the geometry of the given molecules

Borazon, Borazole, $B_3O_6^{3-}$, trimer of FCN.

['P' stands for planer and 'NP' standes for non-planer]

A. NP, NP, NP, P, P

B. P,P,NP,NP,P

C. NP,NP,NP,P,NP

D. NP,P,P,NP,P

Answer: D

 [Watch Video Solution](#)

12. What is not true about borax ?

A. It is a useful primary standard for titrating against acids

B. one mole of borax contains 4B-O-B bonds

C. Aqueous solution of borax can be used as buffer

D. it is made up of two triangular BO_3 units and two tetrahedral BO_4 units

Answer: B

 [Watch Video Solution](#)

13. How can the following reaction be made to proceed in forward direction ?

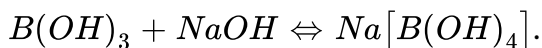

- A. Addition of cis 1,2 diol
- B. addition of borax
- C. addition of trans 1,2 diol
- D. addition of Na_2HPO_4

Answer: A

 [Watch Video Solution](#)

14. Which of the following catio can not give bead test?

- A. Cr^{3+}
- B. Co^{2+}

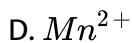
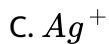

Answer: C

 [Watch Video Solution](#)

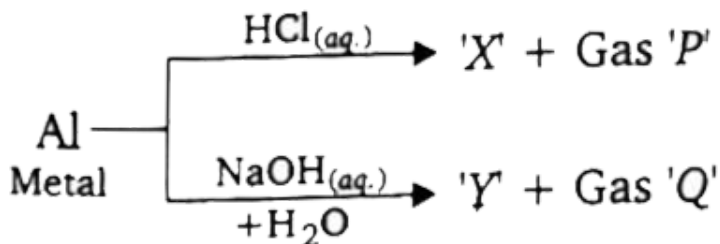

The incorrect statement regarding above reactions is:

A. Al shows amphoteric character

B. Gas 'P' and 'Q' are different

C. Both X and Y are water soluble

D. Gas Q is inflammable

Answer: B



Watch Video Solution

16. The incorrect statement regarding 'X' in given reaction is:

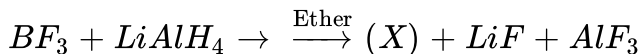

- A. Twelve electrons are involved in bonding
- B. Four, two centre-two electron bonds
- C. Two, three centre-two electron bonds
- D. X does not react with NH_3

Answer: D



Watch Video Solution

17. The incorrect stability order of +3 and +1 states of 13th group elements (boron family) is:

- A. $Ga^{3+} < In^{3+} < Tl^{3+}$

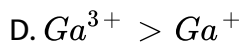
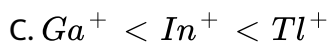
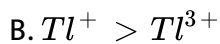

Answer: A

 [Watch Video Solution](#)

18. Consider the following route of reaction:

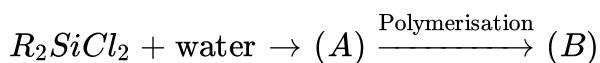

Compound(B) in above reaction is:

A. Dimer silicone

B. Linear silicone

C. Cross linked silicon

D. Polymerisation of (A) does not occur

Answer: B



Watch Video Solution

19. The most basic oxide of elements group 14 of the periodic table is:

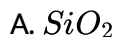

Answer: D



Watch Video Solution

20. $(Si_2O_5)_n^{2n-}$ anion is obtained when:

A. no oxygen of a SiO_4^{4-} tetrahedron is shared with another SiO_4^{4-} tetrahedron

B. one oxygen of a SiO_4^{4-} tetrahedron is shared with another SiO_4^{4-} tetrahedron

C. two oxygen of a SiO_4^{4-} tetrahedron are shared with another SiO_4^{4-} tetrahedron

D. Three oxygen of a SiO_4^{4-} tetrahedron are shared with another SiO_4^{4-} tetrahedron

Answer: D

 [Watch Video Solution](#)

21. Amphibole silicate structure has 'x' number of corner shared per tetrahedron. The value of x is :

A. 2

B. $2\frac{1}{2}$

C. 3

D. 4

Answer: B



Watch Video Solution

22. The silicate ion in the mineral kinoite is a chain of three SiO_4^{4-} tetrahedral that share corners with adjacent tetrahedral. The mineral also contains Ca^{2+} ions, Cu^{2+} ions and water molecules in 1 : 1 : 1 ratio. The mineral is represented as

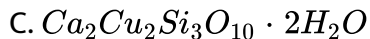
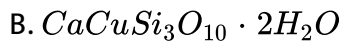
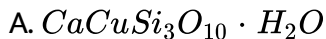

D. none of these

Answer: C



Watch Video Solution

23. Choose the correct order of C-C bond length in the given compounds:

A. Acetylene < ethylene < graphite < benzene < ethane

B. acetylene < ethylene < benzene < graphite < ethane

C. acetylene < graphite < ethylene < benzene < ethane

D. acetylene < benzene < graphite < entylene < ethane

Answer: B



[Watch Video Solution](#)

24. Silicate having one monovalent corner oxygen atom in each tetrahedron unit is:

A. sheet silicate

B. cyclic silicate

C. single chain silicate

D. double chain silicate

Answer: A



Watch Video Solution

25. In which of the following silicates, only two corners per tetrahedron are shared ?

I. Pyrosilicate

II. Cyclic silicate

III Double chain silicate

IV Single chain silicate

V 3D Silicate

A. (i),(ii) and (iv)

B. (iv) and (vi) only

C. (i) and (vi) only

D. (ii) and (iv) only

Answer: D





Watch Video Solution

26. The correct code for stability, of oxidation states for given cations is:

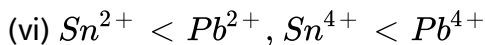
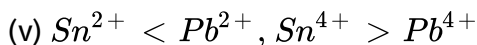
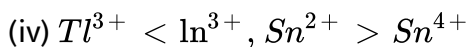
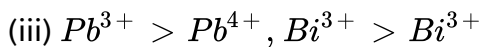
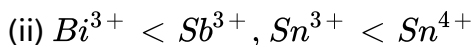
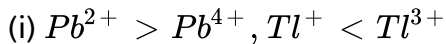

A. (v) and (vi)

B. (i), (iii) and (vi)

C. (iii) and (v)

D. (ii) and (iv)

Answer: C



Watch Video Solution

27. Nitrogen gas is liberated by thermal decomposition of:

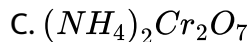
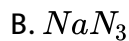
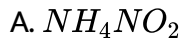

D. all

Answer: D



[Watch Video Solution](#)

28. Two oxides of Nitrogen, NO and NO_2 reacts together at 253 K and form a compound Nitrogen X.X reacts with water to yield another compound of Nitrogen Y. The shape of the anion of Y molecule is

A. triangular planar

B. triangular pyramidal

C. tetrahedron

D. square planar

Answer: A



Watch Video Solution

29. Consider the following sequence of reaction:

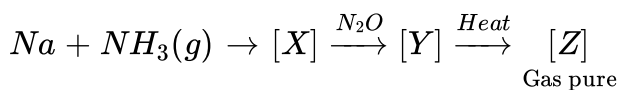

Identify [Z] gas:

A. N_2

B. NH_3

C. O_2

D. H_2

Answer: A



Watch Video Solution

30. Which of the following oxyacid contains both P-H and P-P bond simultaneously?



D. none

Answer: D



Watch Video Solution

31. Among the following statement which one is true?

A. NH_3 is less soluble than PH_3 in water

B. NH_3 is stronger base and stronger reducing agent than PH_3

C. NH_3 has higher boiling point than PH_3 and has lower melting point than PH_3

D. PH_3 is stronger reducing agent than NH_3 and it has lower critical temperature than NH_3

Answer: D

 [Watch Video Solution](#)

32. Which of the following statements regarding N_2O_4 is not correct?

A. It is a planar molecule

B. It is used as non-aqueous solvent

C. It involves N-N bond which is shorter than that N-N bond in hydrazine

D. Ammonium nitrate in N_2O_4 acts as a base

Answer: C

 [Watch Video Solution](#)

33. Which of the following on heating produces NO_2 ?

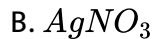
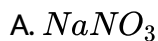

Answer: B



Watch Video Solution

34. Which of the following equation is incorrectly written?

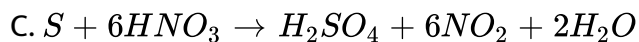
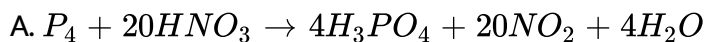

D. none of the above

Answer: B



Watch Video Solution

35. The cyclotrimetaphosphoric acid is:

- A. $(HPO_3)_5$ and contains 9σ -bonds
- B. $H_3P_3O_6$ and contains 12σ – bonds
- C. $(HPO_3)_3$ and contains 15σ -bonds
- D. $H_3P_3O_9$ and contains 18σ -bonds

Answer: C



Watch Video Solution

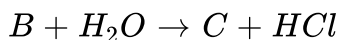
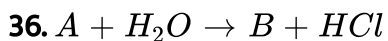

Compound (A), (B) and (C) will be respectively:

A. PCl_5 , $POCl_3$, H_3PO_3

B. PCl_5 , $POCl_3$, H_3PO_4

C. $SOCl_2$, $POCl_3$, H_3PO_3

D. PCl_3 , $POCl_3$, H_3PO_4

Answer: B



Watch Video Solution

37. It is recommended that ammonia bottles be opened after cooling in ice for sometime. This is because

A. brings tears in the eyes

B. is a corrosive liquid

C. is a mild explosive

D. generates high vapour pressure

Answer: D

 [Watch Video Solution](#)

38. Which of the following statements are correct about the reaction between the copper metal and dilute HNO_3 ?

- A. The principle reducing product is NO gas
- B. Cu metal is oxidised to Cu^{2+} (aq.) ion which is blue in colour
- C. NO is paramagnetic and has one unpaired electron in antibonding molecular orbital
- D. NO reacts with O_2 to produce NO_2 which is linear in shape

Answer: A:C

 [Watch Video Solution](#)

39. In which of the following acids, P-P bonds is present?

- A. Tetra poly phosphoric acid ($H_6P_4O_{13}$)

B. Pyrophosphoric acid ($H_4P_2O_7$)

C. Hypophosphoric acid ($H_4P_2O_6$)

D. Polymetaphosphoric acid (HPO_3) $_\pi$

Answer: C

 [Watch Video Solution](#)

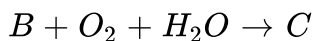
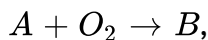
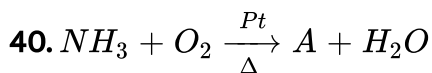

A, B and C are:

A. N_2O , NO_2 and HNO_3

B. NO , NO_2 and HNO_3

C. NO_2 , NO and HNO_3

D. N_2O , NO and HNO_3

Answer: B

 [Watch Video Solution](#)

41. The formation of PH_4^+ is difficult compared to NH_4^+ because:

- A. lone pair of phosphorus is optically inert
- B. lone pair of phosphorus resides in almost pure p-orbital
- C. lone pair of phosphorus resides at sp^3 orbital
- D. lone pair of phosphorus resides in almost pure s-orbitals

Answer: D

 [Watch Video Solution](#)

42. Nitrogen (i) oxide is produced by

- A. thermal decomposition of sodium nitrite at low temperature

B. thermal decomposition of ammonium nitrite

C. disproportionation of N_2O_4

D. interaction of hydroxyl amine and nitrous acid

Answer: D



Watch Video Solution

43. Amongst the following compounds

(I) $H_5P_3O_{10}$

(II) $H_6P_4O_{13}$

(III) $H_5P_5O_{15}$

(IV) $H_7P_5O_{16}$

non-cyclic phosphates are:

A. I,III

B. I,II,III

C. I,II,IV

D. I,II,III,IV

Answer: C

 [Watch Video Solution](#)

44. Match List-I with List-II and select the correct answer using the codes given below the lists:

List-I (Compounds)

- (A) $\text{BaSO}_4 + \text{ZnS}$
- (B) NI_3
- (C) N_2O_4
- (D) KO_2

List-II (used in)

- (1) Explosive
- (2) Oxidiser in rocket propellants
- (3) Space capsule
- (4) Pigment

A. A-3,B-1,C-4,D-2

B. A-4,B-1,C-2,D-3

C. A-3,B-4,C-1,D-2

D. A-4,B-3,C-2,D-1

Answer: B

 [Watch Video Solution](#)

45. Which is the correct sequence in the following properties. For the correct order mark (*T*) and for the incorrect order mark (*F*):

(a) Acidity order : $SiF_4 < SiCl_4 < SiBr_4 < SiI_4$ (b) Melting point : $N < P < As < Sb$
(c) Boiling point : $NH_3 > SbH_3 > AsH_3 > PH_3$ (d) Dipole moment : $N > P > As > Sb$

A. FTFT

B. TFTF

C. FFFT

D. FFTF

Answer: A



[Watch Video Solution](#)

46. An orange solid (X) on heating, gives a colourless gas (Y) and a only green residue (Z). Gas (Y) on treatment with Mg, produces a white solid substance.....

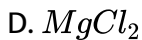
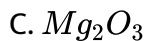
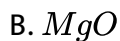
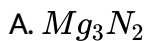

Answer: A

 [Watch Video Solution](#)

47. Calcium imide on hydrolysis will give gas (B) which on oxidation by bleaching powder gives gas (C) gas (C) on reaction with magnesium give compound (D). (D) on hydrolysis gives gas (B). (B), (C) and (D) are

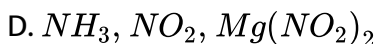
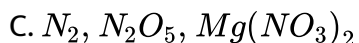
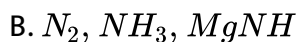
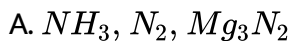

Answer: A



Watch Video Solution

48. Among the following compounds, which on heating do not produce N_2 ?

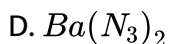
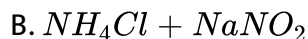
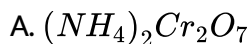

Answer: C



Watch Video Solution

49. In which of the following compounds hydrolysis takes place through S_N1 and S_N2 mechanism respectively?

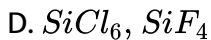
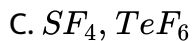
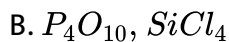
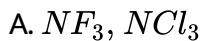

Answer: A

 [Watch Video Solution](#)

50. Incorrect statement about PH_3 is:

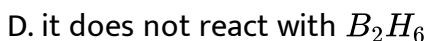
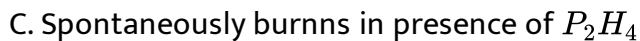
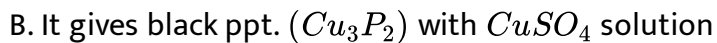
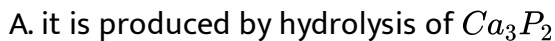

Answer: D

 [Watch Video Solution](#)

51. Which of the following compound does not give oxyacid of central atom on hydrolysis?

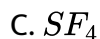
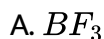

Answer: B



Watch Video Solution

52. The incorrect statement regarding 15th group hydrides (EH_3). [$E = N, P, As, Sb, Bi$]

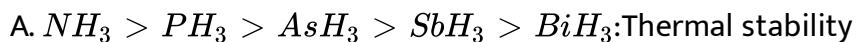

B. $N - H > P - H > As - H > Sb - H > Bi - H, E - H$ bond

dissociation enthalpy

C. $NH_3 > PH_3 > AsH_3 > SbH_3 > BiH_3$: Reducing character

D. $NH_3 > PH_3 > AsH_3 > SbH_3 > BiH_3$: Basicity

Answer: C

 [Watch Video Solution](#)

53. Calculate $x+y+z$ for H_3PO_3 acid, where x is no. of lone pairs, y is no. of σ bonds and z is no. of π bonds.

A. 5

B. 14

C. 13

D. 12

Answer: C

 [Watch Video Solution](#)

54. A non-metal M forms MCl_3 , M_2O_5 and Mg_3M_2 but does not form MI_5 , then incorrect statement regarding non-metal M is

- A. M can form multiple bond
- B. M is of second period element
- C. Atomicity of non-metal is 4
- D. The range of oxidation number for M is -3 to +5

Answer: C

 [Watch Video Solution](#)

55. The incorrect order is:

- A. Thermal stability: $HF > HCl > HBr$
- B. Lewis basic character $PF_3 < PCl_3 < PBr_3$

C. %p-character: $NO_2^+ > NO_3^- > NH_3^+$

D. Bond angle: $NH_3 > PH_3 > AsH_3$

Answer: C

 [Watch Video Solution](#)

56. The correct order of S-S bond length in following oxyanions is:

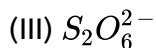
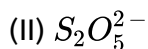
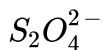

A. $I > II > III$

B. $I > III > II$

C. $III > II > I$

D. $III > I > II$

Answer: A

 [Watch Video Solution](#)

57. In which of the following reaction product does not contain 'peroxy' linkage?

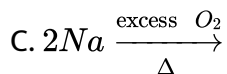
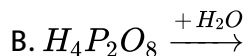
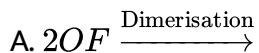

D. none of these

Answer: A



Watch Video Solution

58. Consider the following statements in respect of oxides of sulphur:

(1) in gas phase SO_2 molecule is V_shape.

(2) In gas phase SO_3 molecule is planar.

(3) $\gamma - SO_3$ is cyclic trimer.

Which of the above statements are correct?

A. 1 and 2 only

B. 2 and 3 only

C. 1 and 3 only

D. 1,2 and 3

Answer: D



Watch Video Solution

59. Gas that can not be collected over water is:

A. N_2

B. O_2

C. SO_2

D. PH_3

Answer: C



[Watch Video Solution](#)

60. In thiosulphuric acid:

- A. each sulphur atom is in identical oxidation state
- B. there is a S=S linkage present
- C. one S atom is in +2 and other sulphur atom is in +4 oxidation state
- D. there is only one replaceable hydrogen atom

Answer: B



[Watch Video Solution](#)

61. One gas bleaches the colour of flowers by reduction, while the other by oxidation, the two gases respectively are:

A. CO and Cl_2

B. H_2S and Br_2

C. NH_3 and SO_3

D. SO_2 and Cl_2

Answer: D



Watch Video Solution

62. Which of the following halides cannot be hydrolysed at room temperature?

(I) TeF_6

(II) SF_6

(III) NCl_3

(IV) NF_3

Choose the correct code:

A. III and IV

B. I, II and III

C. I, II and IV

D. II and IV

Answer: D

 [Watch Video Solution](#)

63. By which of the following methods, H_2O_2 can't be synthesised?

A. Lewis addition of ice cold H_2SO_4 on BaO_2

B. Addition of ice cold H_2SO_4 on PbO_2

C. Aerial oxidation of 2-ethyl anthraquinol

D. Electrolysis of $(NH_4)_2SO_4$ at a high current density

Answer: B

 [Watch Video Solution](#)

64. Give the correct order of initials T or F for following statements. Use T if statements is true and F if if false.

(I) Number of $S - S$ bond in $H_2S_nO_6$ are $(n + 1)$

(II) When F_2 reacts with water gives HF , O_2 and O_3

(III) $LiNO_3$ and $BaCl_2$ compounds are used in the fire works

(IV) Be and Mg hydrides are ionic and polymeric

A. FTTF

B. FTTF

C. TFFT

D. TTFF

Answer: A



Watch Video Solution

65. Which of the following parent acid(s) does/do not have corresponding hypo-oxyacid?

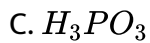
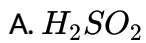

Answer: D

 [Watch Video Solution](#)

66. Which pair of elements can form multiple bond with itself and oxygen?

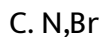

Answer: D

67. Consider the following reactions:

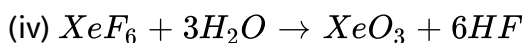
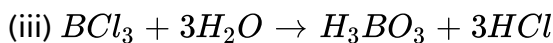
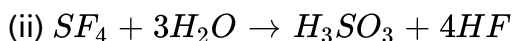
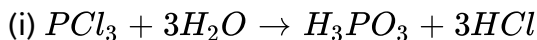

Then according to given information the incorrect statement is:

A. During the (i) reaction the hybridisation of 15th group element does not change

B. During the (ii) reaction the hybridisation of 16th group element does not change

C. During the (iii) reaction the hybridisation of 13th group element does not change

D. During the (iv) reaction the hybridisation of 18th group element does not change

Answer: D

 [Watch Video Solution](#)

68. Consider the oxy acids $HClO_n$ series here value of n is 1 to 4. then incorrect statement regarding these oxyacids is:

- A. Acidic character of oxy acids increases with increasing value of n.
- B. Oxidising power of oxy acids increases with decreasing value of n
- C. thermal stability of oxy acids decreases with increasing value of n.
- D. Cl-O' bond order decreases with decreasing value of n

Answer: C

 [Watch Video Solution](#)

69. The correct statement regarding ClO_n^- molecular ion is:

- A. On decreasing value of 'n', $Cl - O$ bond order increases
- B. On increasing value of 'n', $Cl-O$ bond length increases
- C. On increasing value of n, oxidation number of central atom increases
- D. On increasing value of n, hybrid orbitals on central atom increases

Answer: C

 [Watch Video Solution](#)

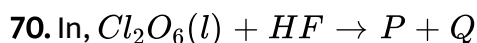

If H^- of acid HF attaches with Q, then correct option of hybridization of Cl-atom and $\angle OClO$ in the P and Q ions:

- A. $P: sp^2, > 120^\circ$
- B. $Q: sp^3: 109^\circ 28'$
- C. $P: sp^3, < 109^\circ 28'$
- D. $Q: sp^3, > 109^\circ 28'$

Answer: B

 [Watch Video Solution](#)

71. Bromine is commercially prepared from sea water by displacement reaction

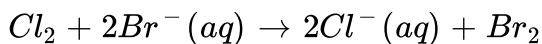

Br_2 gas thus formed is dissolved into solution of Na_2CO_3 and then pure Br_2 is obtained by treatment of the solution with:

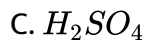
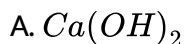

Answer: C

 [Watch Video Solution](#)

72. Which of the following properties of halogens increase with increasing atomic number?

- (I) Ionization energy
- (II) Ionic radius
- (III) Bond energy of the X_2 molecule
- (IV) Enthalpy of vaporisation

A. I,II,III

B. I,III

C. II,IV

D. IV

Answer: C



[Watch Video Solution](#)

73. Predict the correct product when Cl_2 passed through

$H - \overset{18}{O} - \overset{18}{O} - H$ solution.

A. $H^+ + Cl^- + O_2$ (both oxygen having 18)

B. $HOCl$ and $HClO_2$ (all oxygen having 18)

C. $HClO_4$ and HCl (all oxygen having 18)

D. Cl_2O and H_2O (all oxygen having 18)

Answer: A

 [Watch Video Solution](#)

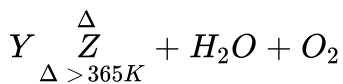
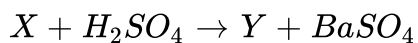
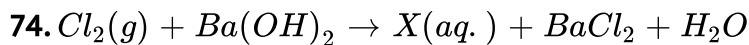

Y and Z are respectively:

A. $HClO_4, ClO_2$

B. $HClO_3, ClO_2$

C. $HClO_3, ClO_6$

D. $HClO_4, Cl_2O_7$

Answer: B

 [Watch Video Solution](#)

75. Auto-oxidation of bleaching powder gives:

- A. only calcium chlorate
- B. only calcium chloride
- C. only calcium hypochlorite
- D. both (a) and (b)

Answer: D

 [Watch Video Solution](#)

76. Which is incorrectly matched?

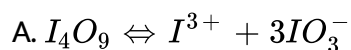

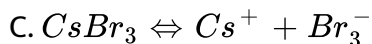
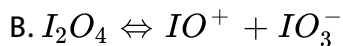

D. none of these

Answer: D

 [Watch Video Solution](#)

77. The three elements X, Y and Z with electronic configuration shown below all form hydrides:

Element	Electronic configuration
X	$1s^2 2s^2 2p^2$
Y	$1s^2 2s^2 2p^6 3s^1$
Z	$1s^2 2s^2 2p^6 3s^2 3p^6 3d^{10} 4s^2 4p^5$

Which set of properties match correctly with properties of the hydrides of these elements:

A. Hydride of X- Colourless gas insoluble in H_2O , Hydride of Y-

Silver/grey solid reacts with H_2O to form an alkali

Hydride of Z-Colourless gas forms a strong acid in H_2O

- B. Hydride of X-Colourless liquid, no reaction with H_2O , Hydride of Y-Silver/grey solid forms H_2 and H_2O , Hydride of Z-Ionic solid with formula ZH
- C. Hydride of X-Non-polar compound reacts with Cl_2 in light, Hydride of Y-Silver/grey ionic solid with formula YH_2 , Hydride of Z-Forms when water is added to phosphorus and elemental Z.
- D. Hydride of X-Colourless gas which burns with air, Hydride of Y-Silver/grey solid which reacts violently with acids, Hydride of Z-Colourless, corrosive liquid at STP

Answer: A



[Watch Video Solution](#)

78. The incorrect order is:

A. $HF < HCl < HBr < HI$: Acidic strength

B. $HF > HCl > HBr > HI$: Thermal stability

C. $HF > HCl > HBr > HI$: Boiling point

D. $HF > HCl > HBr > HI$: bond dissociation enthalpy

Answer: C

 [Watch Video Solution](#)

79. The correct statement regarding perxenate ion (XeO_6^{4-}) is:

A. it is polar species

B. it is a planar species

C. Xe-O' bond order is 1.33

D. Molecular ion has only one type of bond angle

Answer: C

 [Watch Video Solution](#)

80. XeF_2 and XeF_6 are separately hydrolysed then:

- A. both give out O_2
- B. XeF_6 gives O_2 and does not
- C. XeF_2 alone gives O_2
- D. Neither of them gives HF

Answer: C



Watch Video Solution

81. $Mf + XeF_4 \rightarrow M^+ A^-$ (M^+ – alkali metal cation) The state of hybridisation of the central atom in A and shape of the species are:

- A. sp^3d , TBP
- B. sp^3d^3 , distorted octahedral
- C. sp^3d^3 , pentagonal planar
- D. No compound formed at all

Answer: C

 [Watch Video Solution](#)

82. Xenon tetrafluoride, XeF_4 is:

- A. tetrahedral and acts as a fluoride donor with SbF_5
- B. square planar and acts as a fluoride donor with PF_5
- C. square planar and acts as fluoride donor with NaF
- D. see-saw shape and acts as a fluoride donor with AsF_5

Answer: B

 [Watch Video Solution](#)

83. XeF_6 dissolves in anhydrous HF to give a good conducting solution which contains:

- A. H^+ and XeF_7^- ion
- B. HF_2^- and XeF_5^+ ions
- C. $HXeF_6^+$ and F^- ions
- D. none of these

Answer: B

 [Watch Video Solution](#)

84. Which of the following is not true about helium ?

- A. it has the lowest boiling point
- B. it has the highest first ionization energy
- C. it can diffuse through rubber and plastic material
- D. it can form clathrate compounds

Answer: D

 [Watch Video Solution](#)

85. SbF_5 reacts with XeF_4 to form an adduct. The shapes of cation and anion in the adduct are respectively:

- A. square planar, trigonal bipyramidal
- B. T-shaped, octahedral
- C. square pyramidal, octahedral
- D. square planar, octahedral

Answer: B



Watch Video Solution

86. Consider the following transformations:

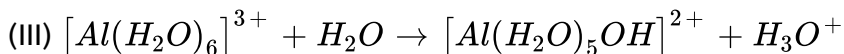
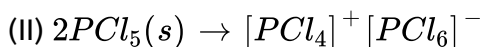
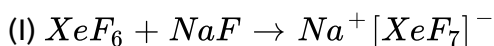

Possible transformations are:

A. I,II,III

B. I,III

C. I,II

D. II,III

Answer: A



Watch Video Solution

87. Which of the following is an uncommon hydrolysis product of XeF_2 and XeF_4 ?

A. Xe

B. XeO_3

C. HF

D. O_2

Answer: B

 Watch Video Solution

88. Incorrect statement regarding following reaction is:

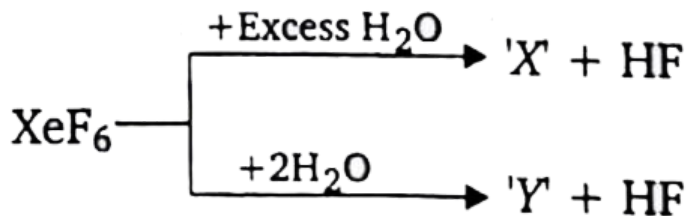

- A. X' is explosive
- B. Y' is an oxyacid of xenon
- C. Both are example of non-redox reaction
- D. XeF_6 can undergo partial hydrolysis

Answer: B

 Watch Video Solution

89. Which of the following noble gases does not form clathrates?

A. Kr

B. Ne

C. Xe

D. Ar

Answer: B

 [Watch Video Solution](#)

90. Correct order of bond angle in given species is:

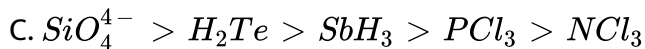
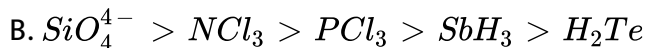
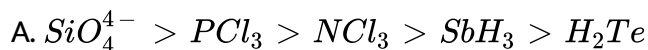

Answer: B

 [Watch Video Solution](#)

91. The incorrect order is:

A. $N > P > As$: strength of π -bond with oxygen atom

B. $SiF_4 > SiCl_4 > SiBr_4 > SiI_4$: Thermal stability

C. $H_2S > H_2Se > H_2Te$: Arrhenius acid character

D. $CaBr_2 > MgBr_2 > BeBr_2$ Melting point

Answer: C



Watch Video Solution

92. Among the following, cyclic species are:

(I) $H_5P_3O_{10}$

(II) $[B_3O_3(OH)_5]^{2-}$

(III) $H_5P_5O_{15}$

(IV) $P_3N_3Cl_6$

A. I,III

B. I,III,IV

C. II,III,IV

D. I,II,III,IV

Answer: C

 [Watch Video Solution](#)

93. The substance that has the lowest boiling point is:

A. HCl

B. H_2S

C. PH_3

D. SiH_4

Answer: D

 [Watch Video Solution](#)

94. Which of the following molecule can show Lewis acidity?

(I) CO_2

(II) Br_2

(III) $SnCl_2$

(IV) HF

A. III,IV

B. I,II,III

C. I,III,IV

D. II,III,IV

Answer: B



[Watch Video Solution](#)

95. Molecule having non-polar as well as polar bonds but the molecule as a whole is polar:

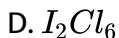
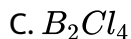
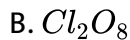

Answer: A::B

 [Watch Video Solution](#)

96. Which of the following order is incorrect?

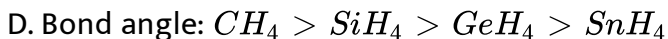
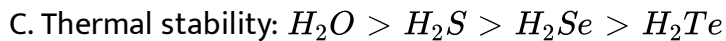
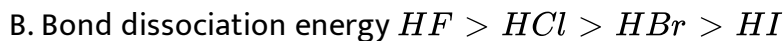
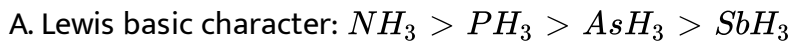

Answer: D

 [Watch Video Solution](#)

97. Which of the following does not undergo Lewis acid-basic reaction?

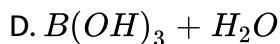
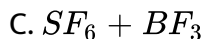
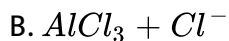
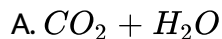

Answer: C



Watch Video Solution

Level 3 Passage Type

1. Each oxy-acid contains at least one X-OH unit (X is non-metal). The H-atom of X-OH unit is ionisable and the number of -OH groups directly attach to non-metal decides the basicity of oxy-acid.

Q. Which of the following oxy-acid does not have its peroxy form having two central atoms?

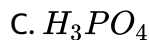
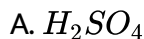

D. none

Answer: B



[Watch Video Solution](#)

2. Each oxy-acid contains at least one X-OH unit (X is non-metal). The H-atom of X-OH unit is ionisable and the number of -OH groups directly attach to non-metal decides the basicity of oxy-acid.

Q. Which of the following oxy-acid does not have its peroxy form having two central atoms?

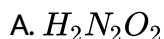

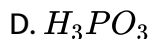
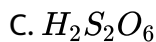
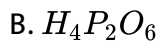

Answer: A



Watch Video Solution

3. Each oxy-acid contains at least one X-OH unit (X is non-metal). The H-atom of X-OH unit is ionisable and the number of -OH groups directly attach to non-metal decides the basicity of oxy-acid.

Q. Which of the following hypoform of oxy-acid ca exhibit tautomerism?

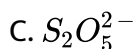
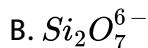
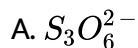

D. none

Answer: C

 Watch Video Solution

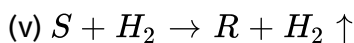
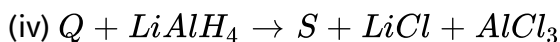
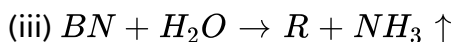
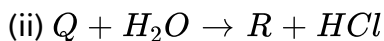
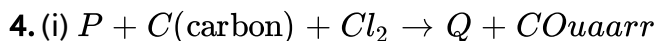

(P,Q,R,S and T do not represent their chemical symbols)

Q. Compound Q has:

(I) zero dipole moment.

(II) a planar trigonal structure

(III) an electron deficient compound

(IV) a lewis base

Chose the correct code:

A. I,IV

B. I,II,IV

C. I,II,III

D. I,II,III,IV

Answer: C



Watch Video Solution

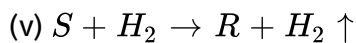
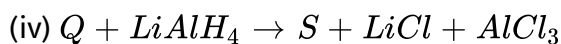
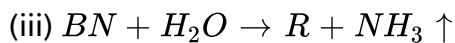
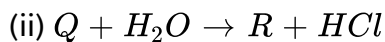
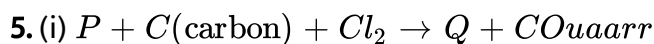

(P,Q,R,S and T do not represent their chemical symbols)

Q. Compound T is used as a/an:

A. oxidising agent

B. complexing agent

C. bleaching agent

D. reducing agent

Answer: D

 [Watch Video Solution](#)

6. (i) $P + C(\text{carbon}) + Cl_2 \rightarrow Q + CO$ (ii) $Q + H_2O \rightarrow R + HCl$ (iii)

$BN + H_2O \rightarrow R + NH_3$ (iv) $Q + LiAlH_4 \rightarrow S + LiCl + AlCl_3$ (v) $S + H_2$

to $R + H_2$ (vi) $S + NaH \rightarrow T$

(P, Q, R, S, T do not represent their chemical symbols) Q. Compound S is

e^- compound (II) $(2c-3e^-)$

compound (III) $ae \leq c$ trond deficient compound (IV) sp^2 hybridized

compound

Choose the correct code:

A. III

B. I, III

C. II, III, IV

D. I,II,IV

Answer: A

 Watch Video Solution

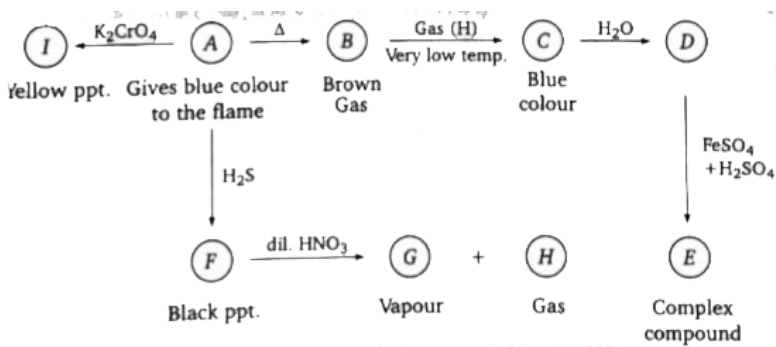

7.

Q. Compound (*D*) + I^- + H^- \rightarrow Gas

Evolved gas is similar to:

A. Gas-B

B. Gas-G

C. Gas-H

D. None

Answer: C

 View Text Solution

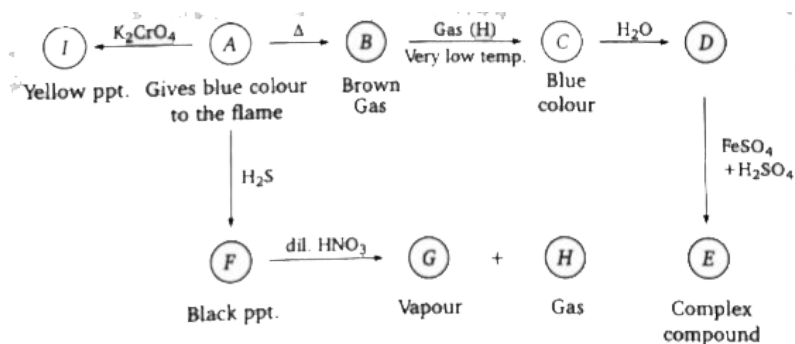

8.

Q. Yellow ppt. of compound (I) is insoluble in:

- A. NaOH
- B. CH_3COOH
- C. dil. HNO_3
- D. none

Answer: B

 View Text Solution

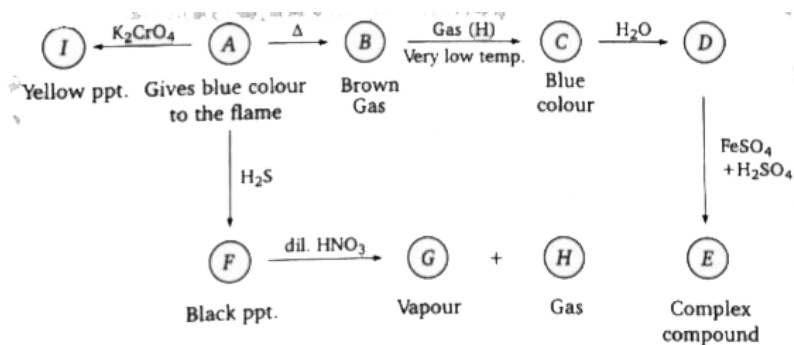

9.

Q. type of hybridization of central atom of gas (B) is:

A. sp

B. sp^2

C. sp^3

D. no hybridization

Answer: B



View Text Solution

10. The following flow diagram represent the industrial preparation of nitric acid from ammonia:

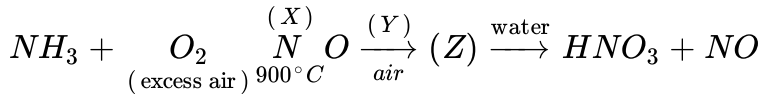

Q. Which line of entry describes the undefined reagents, products and reaction conditions?

A. X-Pt, Y-cool ($- 25^\circ C$), Z- NO_2

B. X-Ni, Y-cool ($- 25^\circ C$), Z- N_2O

C. X-Fe, Y-cool ($- 11^\circ C$), Z- NO_2

D. X-Pd, Y-high pressure, Z- N_2O_3

Answer: A

 [Watch Video Solution](#)

11. The following flow diagram represent the industrial preparation of nitric acid from ammonia:

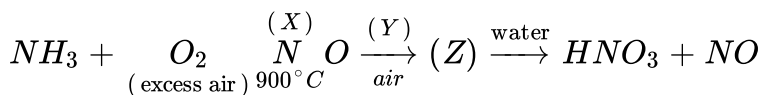

Q. When (Z) is dissolved in H_2O then formation of HNO_3 takes place through various reactions. select the reaction not observed in this step:

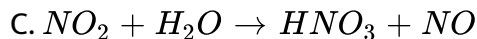
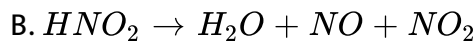
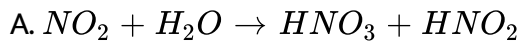

D. none of these

Answer: D

 [Watch Video Solution](#)

12. Species having X-O-H linkage (X=non-metal with positive oxidation state) are called oxy acids and parent acid of a non-metal may exist in two form (a)-ic form of parent oxy acid (b)-us form parent oxy acid.

Q. Number of P-O bond(s) having bond order=2, in $\text{P}_2\text{O}_6^{4-}$ ions is:

A. 0

B. 2

C. 3

D. 6

Answer: A

 [Watch Video Solution](#)

13. Species having X-O-H linkage (X=non-metal with positive oxidation state) are called oxy acids and parent acid of a non-metal may exist in two form (a)-ic form of parent oxy acid (b)-ous form parent oxy acid.

Q. Which of the following parent oxy acid does not have its pyro-oxy acid?

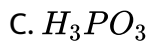
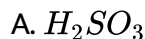

Answer: B

 [Watch Video Solution](#)

14. Species having X-O-H linkage (X=non-metal with positive oxidation state) are called oxy acids and parent acid of a non-metal may exist in two form (a)-ic form of parent oxy acid (b)-ous form parent oxy acid.

Q. X-O-X bond (where X=central atom) is not present in species.

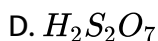
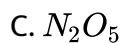
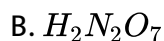
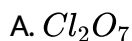

Answer: B

 [Watch Video Solution](#)

15. Consider the following sequence of reactions, if A is sulphuric acid, then give the answer of following questions

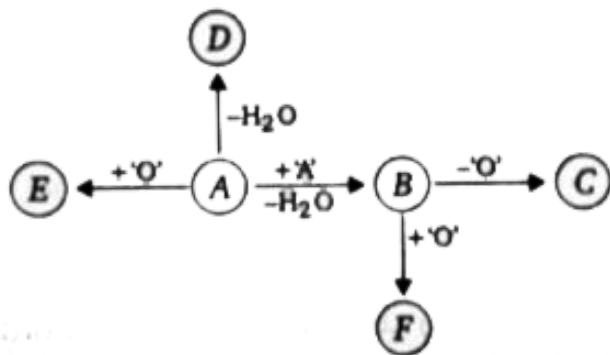

Q. Which of the following oxy acid does not have peroxy (-O-O-) linkage?

- A. F
- B. C
- C. E
- D. None of these

Answer: C

[▶ Watch Video Solution](#)

16. Consider the following sequence of reactions, if A is sulphuric acid, then give the answer of following questions

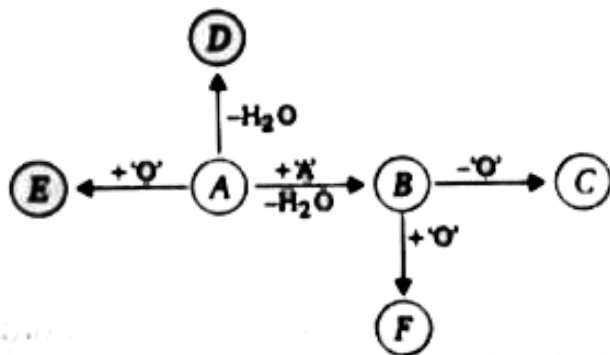

Q. In which of the following compound S-atom is sp^2 hybridised:

- A. C
- B. E
- C. D
- D. B

Answer: C

[Watch Video Solution](#)

17. Consider the following sequence of reactions, if A is sulphuric acid, then give the answer of following questions

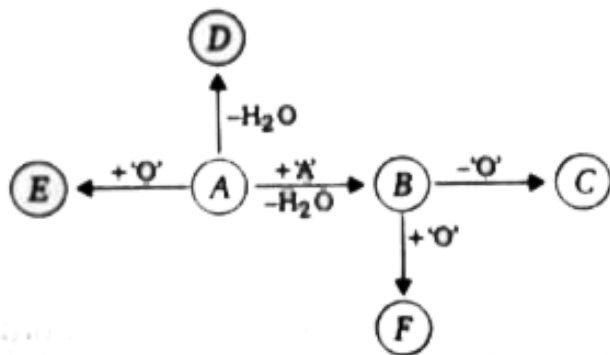

Q. Which of the following oxy acid is having S-O-S linkage?

- A. B
- B. C
- C. F
- D. None of these

Answer: A

 [Watch Video Solution](#)

One Or More Answers Is Are Correct

1. Consider the following reactions,

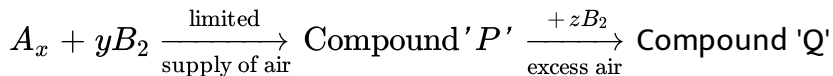

If atomic number of elements A and B are 15 and 8 respectively, then according to the given information the correct statement(s) is/are:

- A. (B-A-B) bond angle in compound 'Q' > (B-A-B) bond angle in compound 'P'
- B. (A-B) bond length in compound 'Q' < (A-B) bond length in compound 'P'
- C. Value of $x + y + z$ is 9
- D. Compound 'P' is P_2O_5 and compound 'Q' is P_4O_{10}

Answer: A::B::C



[Watch Video Solution](#)

2. Which of the following is (are) V-shaped?



Answer: A:D

 Watch Video Solution

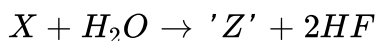
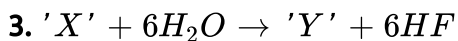

If 'X' is xenon hexafluoride than correct statement is:

A. Compound 'Y' and 'Z' have same number of lone pair(s) at central atom

B. Both compound 'Y and 'Z' have same number of lone pair(s) at central atom

C. Z' is a partially hydrolysed product of compound 'X'

D. X' act as fluoride donor when it reacts with alkali metal fluoride.

Answer: A::B::C

 [Watch Video Solution](#)

4. Which of the following oxy anion(s) contain(s) P-O bond order equal to 1.5?

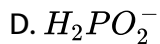
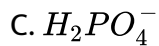
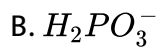
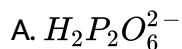

Answer: D

 [Watch Video Solution](#)

5. Which of the following order is correct?

A. $N_2 > F_2 > O_2$: Ionisation energy

B. $H_2Te > H_2Se > H_2S > H_2O$: reducing nature

C. $H_2O > H_2Te > H_2Se > H_2S$: Boiling point

D. $HClO_4 > HClO_3 > HClO_2 > HClO$: oxidising nature

Answer: B::C

 Watch Video Solution

6. Consider the following sequence of reaction

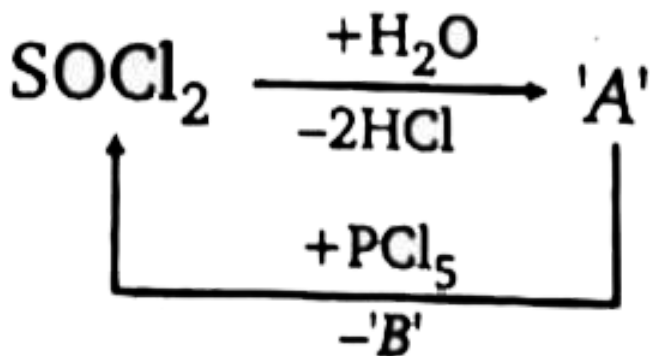

the according to given information the correct statement(s) is/are:

- A. Compound 'A' has $p\pi-p\pi$ bond
- B. central atom of compound B is sp^3 -hybridized
- C. Compound 'B' has plane of symmetry
- D. compound 'A' is polar and B is non-polar

Answer: A::B::C



Watch Video Solution

7. Correct statement(s) about hydrolysis of $H_5P_3O_{10}$ is/are:

- A. $H_4P_2O_6$ can be formed by its partial hydrolysis
- B. Hydrolysis is proceeded by SN_{AE} mechanism
- C. Complete hydrolysis produces H_3PO_4
- D. $H_5P_3O_{10}$ is obtained by hydrolysis of $H_3P_3O_9$

Answer: B::C::D



Watch Video Solution

8. The species which react with silica/glass in presence of moisture:

A. HF

B. XeF_2

C. XeF_4

D. XeF_6

Answer: A::B::C::D



Watch Video Solution

9. In which of the following compound(s) terminal ($2C - 2e^-$) bond and bridge bonds are lying in same plane:

A. I_2Cl_6

B. Fe_2Cl_4

C. Solid $BeCl_2$

D. Ga_2H_6

Answer: A::B

 [Watch Video Solution](#)

10. The correct statement(s) regarding diborane (B_2H_6) is/are:

A. Maximum six hydrogen atoms can lie in a plane

B. Maximum six atoms can lie in a plane

C. Bridging $H_b - B$ bond is stronger than terminal $B-H_t$ bond

D. Terminal $H_t - B - H_t$ bond angle is greater than bridging

$H_b - B - H_b$ bond angle

Answer: B::D

 [Watch Video Solution](#)

11. In which of the compounds oxygen does not exhibit oxidation state (-2)?

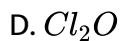
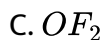
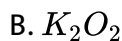

Answer: A::B::C



Watch Video Solution

12. Aqueous solution of boric acid is treated with Salicylic acid. Which of the following statements *is/are* incorrect for the product formed in the above reaction

A. no product will be formed because both are acid

B. product is 4-coordinated complex and optically resolvable

C. product is 4-coordinated complex and optically non-resolvable

D. there are two ring only which are five membered

Answer: A::C::D

 [Watch Video Solution](#)

13. Borazine is called 'inorganic benzene' in view of its ring structure with alternate BH and NH groups. Which of the following statements is correct about borazine?

A. Each B and N atom is sp^2 hybridised

B. Borazine satisfied the $(4n + 2)$ Huckel's rule

C. Like organic benzene, borazine does not give addition product with HCl

D. Borazine contains dative $p\pi - p\pi$ bond

Answer: A::B::D



Watch Video Solution

14. Identify the correct statement about orthoboric acid:

- A. It has a layer structure in which planar BO_3 units are joined by hydrogen bonds
- B. Orthoboric acid (H_3BO_3) is a weak monobasic lewis acid
- C. On heating ortho-boric acid form meta-boric acid and on further heating to red hot, forms boric oxide anhydride
- D. it is obtained by reaction borax with dilute HCl using phenolphthalein as an indicator

Answer: A::B::C



Watch Video Solution

15. Which of the following methods can be used for the preparation of anhydrous aluminium chloride

- A. heating $AlCl_3 \cdot 6H_2O$
- B. Heating a mixture of alumina and coke in a current of dry chlorine
- C. Passing dry HCl gas over heated aluminium powder
- D. Passing dry chlorine over heated aluminium

Answer: B::C::D



[Watch Video Solution](#)

16. Identify the correct statement regarding structure of diborane

- A. There are two bridging hydrogen atoms
- B. Each boron atom forms four bonds
- C. The hydrogen atoms are not in the same plane
- D. each boron atom is in sp^3 hybridized state

Answer: A::B::C::D

 [Watch Video Solution](#)

17. The major product obtained in the reaction of oxalic acid with conc, H_2SO_4 upon heating are

A. CO

B. SO_2

C. CO_2

D. SO_3

Answer: A::C

 [Watch Video Solution](#)

18. Which of the following is/are correct for group 14 elements?

A. The stability of dihalides are in the order

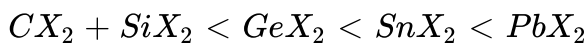

B. The ability of form $p\pi - p\pi$ multiple bonds among themselves increases down the group

C. The tendency for catenation decreases down the group

D. they all form oxides with the formula MO_2

Answer: A::C::D

 [Watch Video Solution](#)

19. Select the correct statement about silicates ?

A. Cyclic silicate having three Si atoms contains six Si-O-Si linkages.

B. $2\frac{1}{2}$ oxygen atoms of per tetrahedron unit are shared in double chain silicate

C. $(Si_2O_5)_n^{2n-}$ is formula of double chain silicate

D. SiO_4^{4-} units polymerize to form silicate because Si atom has less tendency to form π -bond with oxygen

Answer: B::D

 [Watch Video Solution](#)

20. SiO_2 reacts with:

A. Na_2CO_3

B. CO_2

C. HF

D. HCl

Answer: A::C

 [Watch Video Solution](#)

21. Which of the following statement(s) is/are true?

- A. The lattice structure of diamond and graphite are different
- B. Graphite is an impure form of carbon while diamond is a pure form
- C. Graphite is harder than diamond
- D. graphite is thermally more stable than diamond

Answer: A::D



Watch Video Solution

22. On strong heating $Pb(NO_3)_2$ gives:

- A. PbO
- B. NO_2
- C. O_2
- D. NO

Answer: A::B::C

 [Watch Video Solution](#)

23. PbO_2 is:

- A. acidic
- B. basic
- C. reducing agent
- D. oxidising agent

Answer: A::B::D

 [Watch Video Solution](#)

24. Which of the following is true for allotropes of phosphorus?

- A. Yellow phosphorus is soluble in CS_2 while red phosphorus is not

B. P-P-P bond angle is 60° in red phosphorus

C. On heating in air, white phosphorus changes to red

D. White phosphorus slowly changes to red phosphorus at ordinary temperature

Answer: A::D

 [Watch Video Solution](#)

25. Which of the following statements are true about P_4O_6 and P_4O_{10} ?

A. Both these oxides have a closed cage like structure

B. Each oxide requires 6 water molecules for complete hydrolysis to form their respective oxoacids

C. Both these oxides contain 12 equivalent P-O bonds

D. P_4O_6 and P_4O_{10} both contain $p\pi - p\pi$ bonds

Answer: A::B::C



Watch Video Solution

26. Which of the following, when dissolved in water, will liberate ammonia?

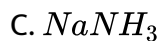
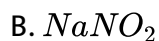
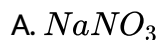

Answer: C::D



Watch Video Solution

27. PH_3 can be obtained by:

A. heating hypophosphorus acid

B. heating orthophosphorus acid

C. reacting white phosphorus with hot conc. NaOH

D. hydrolysis of calcium phosphide

Answer: A::B::C::D

 [Watch Video Solution](#)

28. Which of the following are used as fertilizers?

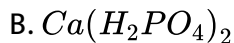
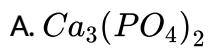

Answer: B::C

 [Watch Video Solution](#)

29. Which of the following statement(s) regarding nitrogen sesquioxide (N_2O_3) is/are correct?

- A. Nitrogen sesquioxide is stable only in the liquid state. It dissociates in the vapour state
- B. Nitrogen sesquioxide is a neutral oxide
- C. Nitrogen sesquioxide contains a weak N-N bond
- D. Nitrogen sesquioxide exists in two different forms

Answer: C::D



Watch Video Solution

30. Photochemical decomposition of HNO_3 produces:

- A. N_2
- B. N_2O
- C. NO_2

D. O_2

Answer: C::D

 [Watch Video Solution](#)

31. Identify the correct statement(s):

A. P_4O_{10} is used as a drying agent

B. P_4O_{10} contains $p\pi - d\pi$ back bonding

C. In P_4O_{10} each P atom is bonded to three oxygen atoms

D. P_4O_{10} hydrolyse in water forming phosphorus acid

Answer: A::B

 [Watch Video Solution](#)

32. Which of the following will be formed when HNO_2 disproportionates in aqueous medium?



Answer: C::D



Watch Video Solution

33. Which of the following species is/are formed when conc. HNO_3 is added to conc. Sulphuric acid?





Answer: B::D

 Watch Video Solution

34. The correct order of reducing power of MH_3 is:

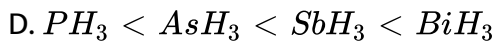
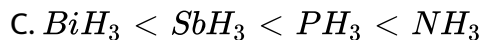
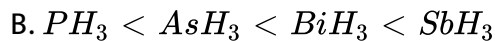
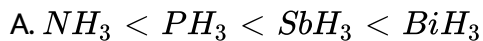

Answer: A::D

 Watch Video Solution

35. Which of the following do not have tendency to act as ligands during complex formation?

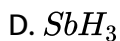
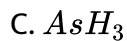
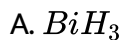

Answer: A::C::D



Watch Video Solution

36. Metal() M in the following equation is/are $M + N_2 \xrightarrow{\Delta}$ Metal nitride



Answer: B::D



Watch Video Solution

37. Which of the following compound(s) is/are explosive(s)?



Answer: B::C::D



Watch Video Solution

38. The compounds obtained by heating of orthophosphoric acid are:

A. metaphosphoric acid

B. pyrophosphoric acid

C. P_4O_6

D. P_4O_{10}

Answer: A::B::D

 [Watch Video Solution](#)

39. At high temperature, nitrogen directly combines with

A. Zn

B. Mg

C. Al

D. Fe

Answer: B::C

 [Watch Video Solution](#)

40. Phosphine is obtained by the reaction when

- A. White phosphorus is heated with NaOH
- B. Ca_3P_2 reacts with water
- C. red phosphorus is heated with NaOH
- D. phosphorus is heated in current of hydrogen

Answer: A::B

 [Watch Video Solution](#)

41. Predict product(s) in the following reaction, $P_4 + OH^- \rightarrow$
product(s)

- A. PH_3
- B. PO_4^{3-}
- C. $H_2PO_2^-$
- D. PO_2^-

Answer: A::C

 [Watch Video Solution](#)

42. Which of the following statements is/are correct?

A. NO_2 is a paramagnetic substance

B. NO_2 solid is brown in colour

C. NO_2 dimerizes to N_2O_4

D. NO_2 is a mixed anhydride

Answer: A::C::D

 [Watch Video Solution](#)

43. Which is true about N_2O_5 ?

A. It is anhydride of HNO_3

B. in solid state it exists as $NO_2^+ NO_3^-$

C. it is structurally similar to P_2O_5

D. it can be prepared by heating HNO_3 over P_2O_5

Answer: A::B::D

 [Watch Video Solution](#)

44. White phosphorus can be separated from red phosphorus by :

A. sublimation

B. dissolving in CS_2

C. distillation

D. none of these

Answer: B

 [Watch Video Solution](#)

45. Orthophosphoric acid $\xrightarrow[220^\circ C]{\text{gentle heat}}$ X

what is/are correct about X?

- A. It is a tetrabasic acid
- B. It contains one P-O-P bond
- C. it is a dibasic acid
- D. On hydrolysis it produces metaphosphoric acid

Answer: A::B



[Watch Video Solution](#)

46. Which of the following act as an oxidizing as well as a reducing agent?

- A. HNO_2
- B. H_2O_2
- C. H_2S
- D. SO_2

Answer: A::B::D



Watch Video Solution

47. Which of the following statements are correct about SF_4 ?

- A. It is prepared by reacting sulphur directly with fluorine
- B. sulphur tetrafluoride hydrolysed by water to give SO_2 and HF
- C. SF_4 has a square planar shape with S having two lone pair of electrons
- D. S-atom has an expanded octet

Answer: B::D



Watch Video Solution

48. Nitrating mixture is obtained by mixing conc. HNO_3 and conc H_2SO_4 . Role of H_2SO_4 in nitration is

A. to force HNO_3 to behave as a base

B. to suppress the dissociation of HNO_3

C. to produce NO_2^+ ions

D. to remove the colour NO_2 produced during nitration

Answer: A:C

 [Watch Video Solution](#)

49. Drops of nitric acid reacts with P_4O_{10} to gives:

A. NO

B. NO_2

C. N_2O_5

D. HPO_3

Answer: C::D

 [Watch Video Solution](#)

50. Which of the following statement(s) is/are correct?

A. Rhombic sulphur is stable at room temperature

B. Monochlinic sulphur is stable at room temperature

C. Both rhombic and monochlinic sulphur has the molecular formula



D. Both rhombic and monochlinic sulphur are soluble in CS_2

Answer: A::C::D



Watch Video Solution

51. Which of the followingg statements are true about sodium thiosulphate, $Na_2S_2O_3$?

A. It isused in the estimation of iodine

B. it can give a black precipitate with $AgNO_3$

C. it is used to remove the unexposed AgBr from photographic films

D. it contains ionic, covalent and coordinate covalent bonds

Answer: A::B::C::D

 [Watch Video Solution](#)

52. Peroxy acids of sulphur are:

A. $H_2S_2O_8$

B. H_2SO_5

C. $H_2S_2O_7$

D. $H_2S_2O_3$

Answer: A::B

 [Watch Video Solution](#)

53. Sulphur dioxide can be used as:

- A. bleaching agent
- B. antichlor
- C. disinfectant
- D. none of these

Answer: A::B::C



Watch Video Solution

54. Which statements are correct for ozone?

- A. it is obtained by silent electric discharge on oxygen
- B. it can be obtained by the action of ultraviolet rays on oxygen
(modified)
- C. it is regarded as an allotrope of oxygen

D. ozone molecules is paramagnetic like oxygen molecule

Answer: A::B::C

 [Watch Video Solution](#)

55. Concentrated sulphuric acid is:

A. efforescent

B. hygroscopic

C. oxidising agent

D. sulphonating agent

Answer: B::C::D

 [Watch Video Solution](#)

56. The reaction of sodium thiosulphate with I_2 gives:

- A. sodium sulphite
- B. sodium sulphate
- C. sodium iodide
- D. sodium tetrathionate

Answer: C::D

 [Watch Video Solution](#)

57. identify the correct statement(s):

- A. Ozone is a powerful oxidising agent as compared to O_2
- B. Ozone reacts with KOH and gives an orange coloured solid KO_3
- C. There is a decrease in volume when ozone decomposed to form O_2
- D. The decomposition of O_3 to O_2 is exothermic

Answer: A::B::D

 [Watch Video Solution](#)

58. Oxygen is not evolved when:

- A. potassium chlorate is heated with MnO_2 catalyst
- B. sodium peroxide reacts with water
- C. ammonium nitrate is heated
- D. zinc oxide is treated with NaOH

Answer: C::D



[Watch Video Solution](#)

59. Identify the correct statements:

- A. Fluorine is a super halogen
- B. iodine shows Lewis basic nature
- C. AgF is insoluble in water

D. SCN^- is a pseudohalide

Answer: A::D

 [Watch Video Solution](#)

60. Which of the following properties of the elements chlorine, bromine and iodine increase with increasing atomic number?

- A. Ionization energy
- B. Ionic radius
- C. Bond energy of the molecule X_2
- D. Enthalpy of vaporization

Answer: B::D

 [Watch Video Solution](#)

61. Which of the following statement(s) is/are correct?

- A. Chlorine dioxide (ClO_2) is powerful oxidising agent but bleaching action is lower than Cl_2
- B. ClO_2 in alkaline solution undergoes disproportionation
- C. ClO_2 is diamagnetic in nature
- D. ClO_2 is a yellow gas but deep red liquid

Answer: B::D



Watch Video Solution

62. Which of the following statement is true about NO_2 and ClO_2 ?

- A. Both are paramagnetic
- B. Both have a bent structure
- C. On cooling, both undergoes dimerisation

D. In both oxides, the central atom has an oxidation state +4.

Answer: A::B::D



Watch Video Solution

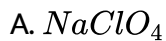
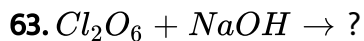

Answer: A::D



Watch Video Solution

64. Predict product(s) in the following reaction,

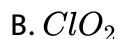

Answer: A::D



Watch Video Solution

65. In the isolation of fluorine a number of difficulties were encountered.

Which statements are correct:

A. Fluorine reacts with moist glass vessels

B. Fluorine gas great affinity for hydrogen

C. Electrolysis of aqueous HF gives ozonized oxygen

D. the potential required for the discharge of the fluoride ions lowest

Answer: A::B::C

 [Watch Video Solution](#)

66. Iodine is formed when potassium iodide reacts with:

A. $ZnSO_4$

B. $CuSO_4$

C. Cl_2

D. Br_2

Answer: B::C::D

 [Watch Video Solution](#)

67. Available Cl_2 is liberated from bleaching powder when it :-

A. is heated

B. reacts with acid

C. reacts with H_2O

D. reacts with CO_2

Answer: B::C::D

 [Watch Video Solution](#)

68. Which reactions are used for the preparation of the halogen acid?

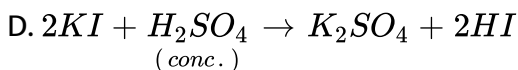
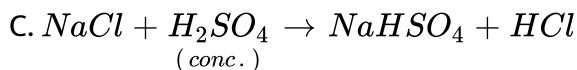
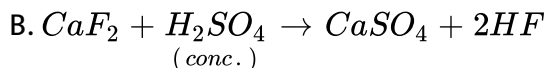
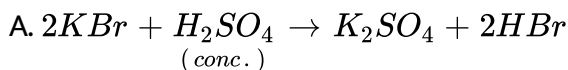

Answer: B::C

 [Watch Video Solution](#)

69. Which of the following statement(s) is/are correct for halogens

- A. halogen which is liquid at room temperature is bromine
- B. the most electronegativity element is fluorine
- C. the most reactive halogen is fluorine
- D. the strongest oxidising agent is iodine

Answer: A::B::C



Watch Video Solution

70. What are products in the following equation, $S + OH^- \rightarrow ?$

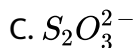



Answer: B::C

 [Watch Video Solution](#)

71. Correct statements about the hydrogen halides include that:

A. they are all coloured

B. the thermal stability decreases with increasing atomic number of halogen

C. they all form soluble silver salts

D. they all donate protons to water

Answer: B::D

 [Watch Video Solution](#)

72. Which of the following statement(s) is/are not correct?

- A. The covalency of N in HNO_3 is +5
- B. HNO_3 in the gaseous state has a trigonal planar structure
- C. The oxidation state of N in HNO_3 is +4
- D. Gold dissolves in HNO_3 to form gold nitrate

Answer: A::C::D



Watch Video Solution

73. Which of the substances react with water?

- A. Chlorine
- B. Phosphorus trichloride
- C. Silicon tetrachloride
- D. Tetrachloro methane

Answer: A::B::C

 [Watch Video Solution](#)

74. Which of the following substances are soluble in NaOH solution?

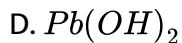
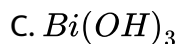
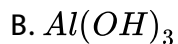
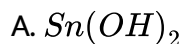

Answer: A::B::D

 [Watch Video Solution](#)

75. Which of the following will give N_2 when heated?

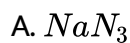

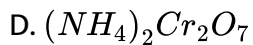

Answer: A::B::D

 [Watch Video Solution](#)

76. Which of the following will give NO_2 when heated?

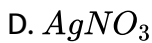
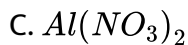
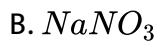

Answer: A::C::D

 [Watch Video Solution](#)

77. identify the correct statements:

A. Calcium cyanamide on treatment with steam under pressure gives



B. PCl_5 is kept in well stopped bottle because it reacts readily with

moisture

C. Ammonium nitrite on heating gives ammonia and nitrous acid

D. Cane sugar reacts with conc. HNO_3 to form oxalic acid

Answer: A::B::D



Watch Video Solution

78. Select the correct statement(s):

A. When Al is added to potassium hydroxide solution, hydrogen gas

is evolved

B. H_2SiF_6 is formed when silica reacts with hydrogen fluoride

followed by hydrolysis

C. Phosphine gas is formed when red phosphorus is heated with

NaOH

D. $(NH_4)_2SO_4 \cdot FeSO_4 \cdot 6H_2O$ is called alums

Answer: A::B



[Watch Video Solution](#)

79. Which of the following gases on dissolution in water make the solution acidic?

A. CO

B. CO_2

C. SO_3

D. PH_3

Answer: B::C

 [Watch Video Solution](#)

80. Which of the following oxides is/are neutral?

A. N_2O

B. CO

C. Al_2O_3

D. NO

Answer: A::B::D

 [Watch Video Solution](#)

81. Which of the following statement(s) is/are incorrect about borazine (inorganic benzene)?

- A. It contains $p\pi - p\pi$ bond
- B. it does not give addition product with HCl like organic benzene
- C. each boron and nitrogen atom is sp^2 -hybridised
- D. Its disubstituted derivatives gives equal no. of ortho, meta and para derivatives like disubstituted organic benzene

Answer: B::D

 [Watch Video Solution](#)

82. Select the correct statement(s) regarding structure of $Al_2(CH_3)_6$:

- A. All carbon atoms of $-CH_3$ groups do not lie in the same plane
- B. One vacant orbital of each Al-atom is involved in sp^3 -hybridisation
- C. There are only 8 sp^3 -hybridised atoms are present
- D. There are total 48 bonding electrons are available

Answer: A::B::C::D



Watch Video Solution

83. Which of the following statement(s) is/are correct about SF_4 molecule?

- A. it has a square planar shape with S-atom having two lone pairs
- B. It is hydrolysed by water to give H_2SO_3 and HF as final products
- C. During hydrolysis, S-atom in transition state is sp^3d^2 hybridised
- D. All S-F bond lengths are equal

Answer: B::C



Watch Video Solution

84. Which of the given compound(s) can act as Lewis acid in both monomer and dimer form?

- A. BH_3

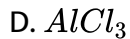
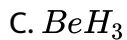

Answer: A::B::C::D

 [Watch Video Solution](#)

85. Which of the following parent acid(s) does/do not have corresponding hypo-oxyacid?

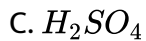
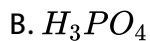

Answer: A::D

 [Watch Video Solution](#)

86. Oxy anion(s) containing (6,2) pair of equivalent X-O linkaes (where X-central atom) is/are:

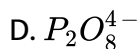
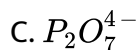
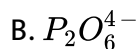
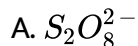

Answer: A::C::D

 [Watch Video Solution](#)

87. Which of the following reactions of xenon compounds in not feasible?

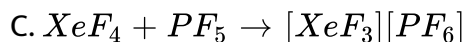
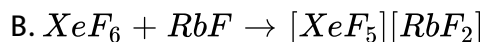

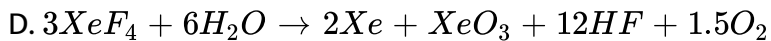

Answer: A::B

 [Watch Video Solution](#)

88. Select the incorrect statement(s):

A. NH_3 has a highest dipole moment among CO , NH_3 and NF_3

B. HF has a highest boiling point among CH_4 , NH_3 and HF

C. Cl_2 has a highest boiling point among Cl_2 , Br_2 and I_2

D. $HClO_3$ is weakest acid among HIO_3 , $HBrO_3$ and $HClO_3$

Answer: C:D

 [Watch Video Solution](#)

89. The possible product (s) formed in the following reaction is/are:

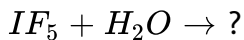

Answer: A::D



Watch Video Solution

90. Which of the following species does / do not exist ?

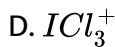
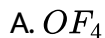

Answer: A::C::D

 Watch Video Solution

91. Consider the following table:

Compound	Enthalpy of formation (kJ mol ⁻¹)	Bond angle (H—C.A.—H)	Boiling point (°C)
H ₂ O	x_1	y_1	z_1
H ₂ S	x_2	y_2	z_2
H ₂ Se	x_3	y_3	z_3
H ₂ Te	x_4	y_4	z_4

According to given information of correct order is/are:

A. $x_1 > x_2 > x_3 > x_4$

B. $y_1 > y_2 > y_3 > y_4$

C. $z_1 > z_4 > z_3 > z_2$

D. $x_1 > x_4 > x_3 > x_2$

Answer: A::B::C

 Watch Video Solution

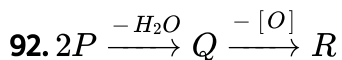

If P is parent phosphoric acid then according to given information the correct statement is/are:

- A. Q is pyro form and R is hypo form of given present oxy acid P
- B. Number of H-atoms present in each given oxy acid is equal to its basicity
- C. In P, Q, R oxy acids, oxidation state of central atom remains same.
- D. All given oxy acids have $p\pi - d\pi$ bond(s) in their structure

Answer: A::B::D

 [Watch Video Solution](#)

93. Choose the correct statement regarding PCl_5

- A. In solid phase, hybridisation of P-atom in cation is sp^3
- B. In vapour phase, all P-Cl bond lengths are equal

C. In vapour and solid phase, central atom has no lone pair

D. In solid phase, anion has only one type of bond angle

Answer: A::C

 [Watch Video Solution](#)

94. Correct order(s) is/are:

A. Thermal stability: $H_2O > H_2S > H_2Se > H_2Te$

B. Bond dissociation energy: $Cl_2 > Br_2 > F_2 > I_2$

C. Melting point: $NH_3 > SbH_3 > AsH_3 > PH_3$

D. $X - C - X$ bond angle: $COCl_2 > COF_2$

Answer: A::B::C::D

 [Watch Video Solution](#)

95. Which of the following reaction(s) do/does not give an oxo-acid?

A. Two moles of nitric acid $\xrightarrow{-H_2O}$

B. One mole of sulphurous acid $\xrightarrow{-H_2O}$

C. Two mole of Chloric acid $\xrightarrow{-H_2O}$

D. Two moles of sulphuric acid $\xrightarrow{-H_2O}$

Answer: A::B::C

 Watch Video Solution

Match The Column

	Column-II (Property)
(A) $NH_3 > PH_3 > AsH_3 > SbH_3$	(P) Melting point
(B) $H_2O > H_2S > H_2Se > H_2Te$	(Q) Lewis acid character
(C) $AlCl_3 > AlBr_3 > AlI_3$	(R) Thermal stability
(D) $Si_2 > BBr_3 > BCl_3 > BF_3$	(S) Lewis basic character

1.

 View Text Solution

Column-I

- (A) Does not neutralise dil. HNO_3
- (B) Reaction with HF acid
- (C) Solid at room temperature
- (D) May act as reducing agent

Column-II

- (P) SiO_2
- (Q) PbO_2
- (R) CO
- (S) SnO
- (T) NO

2.

 [View Text Solution](#)**Column-I
(Hydrolysed Products)**

- (A) H_2 gas is evolved
- (B) Proton donor oxyacid is formed
- (C) Halogen acid is formed
- (D) Back bonding is present in formed oxyacid

Column-II (Compounds that undergo hydrolysis)

- (P) CaH_2
- (Q) POCl_3
- (R) NCl_3
- (S) B_2H_6
- (T) R_2SiCl_2

3.

 [View Text Solution](#)

Column-I

- (A) POCl_3
 (B) SOF_2
 (C) XeOF_4
 (D) $\text{H}_2\text{S}_2\text{O}_8$

Column-II

- (P) Oxyacid formed during hydrolysis undergoes Tautomeric change
 (Q) Oxidation state of central atom does not change during hydrolysis
 (R) Complete as well as partial hydrolysis is possible
 (S) Hydrolysed product reacts with glass
 (T) Hybridization of central atom in the final product remains same as in the substrate on hydrolysis

4.

 [View Text Solution](#)

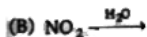
Column-I**(Complete hydrolysis)****Column-II (Characteristics of any hydrolysed product/hydrolysis)**

- (P) Dibasic acid
 (Q) Can act as flexidentate ligand
 (R) Can act as both oxidising and reducing agent
 (S) Can act as monodentate ligand
 (T) Non-redox hydrolysis

5.

 [View Text Solution](#)

Column-I

- (A) Disproportionation in alkaline medium/heating
- (B) Oxidizing agent
- (C) Reacts with water/hydrolysis
- (D) Basic gas evolves on heating

Column-II

- (P) Cl_2
- (Q) NO_2
- (R) XeF_6
- (S) NaH_2PO_3
- (T) $(\text{NH}_4)_2\text{S}$

6.

 [View Text Solution](#)

Match the Column-I with the graph of Column-II which is most close to the answer

Column-I

Column-II

- (A) Bond energies of the hydra acids of the halogens
fluorine, chlorine, bromine, iodine

(P)

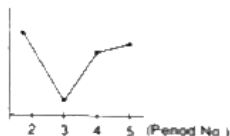

- (B) Boiling points of the hydrides of the 16 group elements
oxygen, sulphur, selenium, tellurium

(Q)

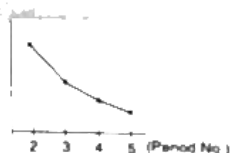

- (C) The stability of monochlorides of group 13 elements
boron, aluminum, gallium, indium

(R)

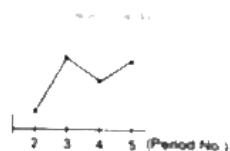

7.

- (D) Melting points of the dioxides of the group 14 elements
carbon, silicon, germanium, tin

(S)

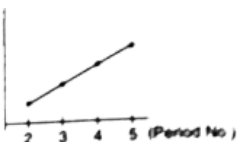

Column-I contains four statements following reason and Column-II consists of four options P, Q, R, S.

Answer the following :

P → If both statement and reason are true and reason is correct explanation of statement.

Q → If both statement and reason are true and reason is not correct explanation of statement.

R → If statement is correct and reason is incorrect.

S → If both statement and reason are incorrect.

Column-I

Column-II

- | | |
|---|---|
| (A) Statements : PbI_4 is a stable compound | P |
| Reason : Iodide stabilizes higher oxidation state. | |
| (B) Statements : White phosphorus is more reactive than red phosphorus. | Q |
| Reason : Red phosphorus consists of P_4 tetrahedral units linked to one another to form linear chains. | |
| (C) Statement : Caro's acid has sulphur atom in sp^3 hybridized state. | R |
| Reason : Caro's acid contains one peroxy O_2^{2-} linkage. | |
| (D) Statement : Bleaching action of chlorine is permanent while that of SO_2 is temporary. | S |
| Reason : Chlorine bleaches by reduction and SO_2 by oxidation. | |

8.



View Text Solution

Column-I

Column-II

- | | |
|--|------------------------|
| (A) Negative charge on the anion is equal to the number of terminal oxygen atoms | (P) $Si_4O_{13}^{10-}$ |
| (B) Three shared corners and ten unshared corners | (Q) SiO_4^{4-} |
| (C) Silicon atom(s) is/are present at the center of geometry and every oxygen atom is present at each corner of the geometry | (R) $Si_4O_{12}^{8-}$ |
| (D) Non-planar geometry | (S) $Si_2O_7^{4-}$ |

9.



- 10.
- | List-I
(Mixtures) | List-II
(Solution used for separation) |
|-----------------------|---|
| (A) N_2 and CO | (P) Water |
| (B) N_2 and O_2 | (Q) H_2SO_4 acid |
| (C) N_2 and NH_3 | (R) Ammonical CuCl |
| (D) PH_3 and NH_3 | (S) Pyrogallol |

 View Text Solution

11. Match the following columns

Column-I (Metal with HNO_3)	Column-II (Main product)
(A) Mg + very dil. HNO_3	(P) NO
(B) Zn + dil. HNO_3	(Q) H_2
(C) Sn + dil. HNO_3	(R) N_2O
(D) Pb + dil. HNO_3	(S) NH_4NO_3

 Watch Video Solution

12. Match the following columns

Column-I

- (A) Moissan method
- (B) Ostwald process
- (C) Deacon process
- (D) Baeyer process

Column-II

- (P) Purification of bauxite
- (Q) Manufacture of Cl_2
- (R) Manufacture of HNO_3
- (S) Isolation of F_2

 [Watch Video Solution](#)

13. Match the following columns

**Column-I
(Oxy acid)**

- (A) HOCl
- (B) HNO_3
- (C) H_3PO_4
- (D) HClO_4

**Column-II
(Acid anhydride)**

- (P) N_2O_5
- (Q) Cl_2O_7
- (R) Cl_2O
- (S) NO_2
- (T) P_4O_{10}

 [Watch Video Solution](#)

- | Column-I | Column-II |
|--------------------------------------|------------|
| (A) Maximum solubility in water | (P) F_2 |
| (B) Corrosive liquid | (Q) Cl_2 |
| (C) Maximum interatomic distance | (R) Br_2 |
| (D) Maximum enthalpy of dissociation | (S) I_2 |
- 14.

 [Watch Video Solution](#)

15. Match the following columns

- | Column-I | Column-II |
|---|-----------------------|
| (A) Borax $\xrightarrow{\Delta}$ | (P) BN |
| (B) $B_2H_6 + H_2O \rightarrow$ | (Q) B_2H_6 |
| (C) $B_2H_6 + NH_3(\text{excess}) \xrightarrow{\Delta}$ | (R) H_3BO_3 |
| (D) $BCl_3 + LiAlH_4 \rightarrow$ | (S) $NaBO_2 + B_2O_3$ |

 [Watch Video Solution](#)

16. Match the following columns

Column-I
(Catalyst involved in process)

- (A) Platinum
- (B) V_2O_5
- (C) Iron
- (D) Cobalt chloride

Column-II
(Process)

- (P) Decomposition of bleaching powder
- (Q) Manufacturing of HNO_3
- (R) Manufacturing of H_2SO_4
- (S) Manufacturing of NH_3
- (T) Hydrogenation

 [Watch Video Solution](#)

17. Match the following columns

Column-I

- (A) Hypo phosphoric acid
- (B) Pyro phosphoric acid
- (C) Boric acid
- (D) Hypo phosphorus acid

Column-II

- (P) All hydrogen are ionizable in water
- (Q) Lewis acid
- (R) Monobasic in water
- (S) sp^3 hybridized central atom

 [Watch Video Solution](#)

18. Match the following columns

Column-I	Column-II
(A) CO_2	(P) Acidic oxide
(B) SO_2	(Q) Colourless
(C) NO_2	(R) Paramagnetic
(D) N_2O	(S) Coloured

 [Watch Video Solution](#)

Column-I	Column-II
(A) $\text{Na}_2\text{B}_4\text{O}_7 \cdot 10\text{H}_2\text{O}$	(P) Basic solution
(B) Na_2CO_3	(Q) Acidic solution
(C) $\text{K}_2\text{SO}_4 \cdot \text{Al}_2(\text{SO}_4)_3 \cdot 24\text{H}_2\text{O}$	(R) can react with NaOH
(D) NH_4Cl	(S) Swells up on heating

19.

 [View Text Solution](#)

20. Match the following columns

Column-I	Column-II
(A) SiO_2	(P) React with HF
(B) CN^-	(Q) Pseudo halide
(C) I^-	(R) Gives compound with Cu^{2+} via redox Rxn
(D) SnO_2	(S) Can dissolve in alkali

 [Watch Video Solution](#)

21. Match the following columns

Column-I	Column-II
(A) Sheet silicate	(P) $(\text{SiO}_3)_n^{2n-}$
(B) Pyroxene chain	(Q) $(\text{Si}_4\text{O}_{11})_n^{6n-}$
(C) Pyro silicate	(R) 3-corner oxygen atom are shared
(D) Amphibole chain	(S) Non-planar

 [Watch Video Solution](#)

22. Match the following columns

Column-I	Column-II
(A) Br_2	(P) Liquid at room temperature
(B) O_2	(Q) Used in estimation of CO
(C) ClO_2	(R) Paramagnetic
(D) I_2O_5	(S) Powerful bleaching agent

 [Watch Video Solution](#)

Column-I	Column-II
(A) $\text{NH}_3 > \text{PH}_3 > \text{AsH}_3 > \text{SbH}_3$	(P) Reducing property
(B) $\text{KF} > \text{KCl} > \text{KBr} > \text{KI}$	(Q) Heat of fusion (M.P)
(C) $\text{H}_2\text{O} > \text{H}_2\text{S} > \text{H}_2\text{Se} > \text{H}_2\text{Te}$	(R) Thermal stability
(D) $\text{CH}_4 < \text{SiH}_4 < \text{GeH}_4 < \text{SnH}_4$	(S) Lewis basic character

23.

 [View Text Solution](#)

24. Match the following columns

Column-I (Catalyst involved in process)	Column-II (Process)
(A) SF_4	(P) Can act as Lewis acid as well as Lewis base
(B) AsH_3	(Q) Central atom belongs to 16th or 17th group
(C) ClO_4^-	(R) Non-axial set of <i>d</i> -orbitals do not use in bonding
(D) $SbCl_5$	(S) Only one type bond angle
	(T) Oxidation state of central atom is +4 or greater than +4

 [Watch Video Solution](#)

Assertion Reason Type Questions

1. Assertion: $Al(OH)_3$ is amphoteric in nature.

Reason: $Al(OH)_3$ is H^+ donar acid as well as OH^- donar base.

A. If both (A) and (R) are true and (R) is the correct explanation of (A)

B. if both (A) and (R) are true but (R) is not correct explanation of (A)

C. If (A) is true but (R) is false

D. If (A) is false but (R) is false

Answer: C

 [Watch Video Solution](#)

2. Assertion: BF_3 is weaker lewisi acid than BCl_3 .

Reason: BF_3 is less electron deficient than BCl_3 .

A. If both (A) and (R) are true and (R) is the correct explanation of (A)

B. if both (A) and (R) are true but (R) is not correct explanation of (A)

C. If (A) is true but (R) is false

D. If (A) is false but (R) is false

Answer: A

 [Watch Video Solution](#)

3. Assertion: When two gaseous OF molecules are allowed to cool, then they undergo dimerisation through O-atom.

Reason: Dimerr form of OF molecule (i.e, O_2F_2) is having one peroxy linkage in its structure.

- A. If both (A) and (R) are true and (R) is the correct explanation of (A)
- B. if both (A) and (R) are true but (R) is not correct explanation of (A)
- C. If (A) is true but (R) is false
- D. If (A) is false but (R) is false

Answer: C

 [Watch Video Solution](#)

4. Assertion : bond dissociation energy of $N - F$ bond in NF_3 molecule is lower than that of in NCl_3 molecule.

Reason : Interelectronic repulsion exists between small size N and F atoms $N - F$ bond of NF_3 molecule.

- A. If both (A) and (R) are true and (R) is the correct explanation of (A)
- B. if both (A) and (R) are true but (R) is not correct explanation of (A)
- C. If (A) is true but (R) is false
- D. If (A) is false but (R) is false

Answer: D

 [Watch Video Solution](#)

5. Assertion: $NaBO_3 / OH^-$ can be used for oxidation of Cr^{3+} to Cr^{6+}

Reason: IN alkaline medium $NaBO_3$ produces H_2O_2

- A. If both (A) and (R) are true and (R) is the correct explanation of (A)
- B. if both (A) and (R) are true but (R) is not correct explanation of (A)
- C. If (A) is true but (R) is false
- D. If (A) is false but (R) is false

Answer: A

 [Watch Video Solution](#)

6. Assertion: Aluminium and zinc metal evolve H_2 gas from NaOH solution

Reason: Several non-metals such as P,S,Cl, etc. yield a hydride instead of H_2 gas from NaOH

- A. If both (A) and (R) are true and (R) is the correct explanation of (A)
- B. if both (A) and (R) are true but (R) is not correct explanation of (A)
- C. If (A) is true but (R) is false
- D. If (A) is false but (R) is false

Answer: B::C

 [Watch Video Solution](#)

7. Assertion: There is a very little difference in acidic strengths of H_3PO_4 , H_3PO_3 and H_3PO_2 .

reason: Number of unprotonated oxygen (=O) responsible for increase of acidic strength due to inductive effective remains the same.

- A. If both (A) and (R) are true and (R) is the correct explanation of (A)
- B. if both (A) and (R) are true but (R) is not correct explanation of (A)
- C. If (A) is true but (R) is false
- D. If (A) is false but (R) is false

Answer: A



Watch Video Solution

8. Statement-I : PCl_5 and $PbCl_4$ are thermally unstable.

Statement-II : They produce same gas on thermal decomposition

- A. If both (A) and (R) are true and (R) is the correct explanation of (A)
- B. if both (A) and (R) are true but (R) is not correct explanation of (A)
- C. If (A) is true but (R) is false

D. If (A) is false but (R) is false

Answer: B::C

 [Watch Video Solution](#)

9. Concentrated H_2SO_4 cannot be used to prepare HBr from NaBr ,
because it ,

A. If both (A) and (R) are true and (R) is the correct explanation of (A)

B. if both (A) and (R) are true but (R) is not correct explanation of (A)

C. If (A) is true but (R) is false

D. If (A) is false but (R) is false

Answer: C

 [Watch Video Solution](#)

10. Statement-1: Oxygen is more electronegative than sulphur, yet H_2S is acidic, while H_2O is neutral.

Statement-2: $H - S$ bond is weaker than $O - H$ bond.

- A. If both (A) and (R) are true and (R) is the correct explanation of (A)
- B. if both (A) and (R) are true but (R) is not correct explanation of (A)
- C. If (A) is true but (R) is false
- D. If (A) is false but (R) is false

Answer: A



[Watch Video Solution](#)

11. Assertion: Liquid IF_5 conducts electricity.

Reason: Liquid IF_5 conducts as, $2IF_5 \rightleftharpoons IF_4^+ + IF_6^-$.

- A. If both (A) and (R) are true and (R) is the correct explanation of (A)
- B. if both (A) and (R) are true but (R) is not correct explanation of (A)

C. If (A) is true but (R) is false

D. If (A) is false but (R) is true

Answer: A

 [Watch Video Solution](#)

12. Assertion: Red phosphorus is less volatile than white phosphorus.

Reason: Red phosphorus has a discrete tetrahedral structure.

A. If both (A) and (R) are true and (R) is the correct explanation of (A)

B. If both (A) and (R) are true but (R) is not correct explanation of (A)

C. If (A) is true but (R) is false

D. If (A) is false but (R) is false

Answer: C

 [Watch Video Solution](#)

13. Assertion: $Al(OH)_3$ is amphoteric in nature. Reason: It cannot be used as an antacid.

- A. If both (A) and (R) are true and (R) is the correct explanation of (A)
- B. if both (A) and (R) are true but (R) is not correct explanation of (A)
- C. If (A) is true but (R) is false
- D. If (A) is false but (R) is false

Answer: C



[Watch Video Solution](#)

14. Assertion: Chlorine gas disproportionates in hot and conc. NaOH solution.

Reason: NaCl and NaOCl are formed in the above reaction.

- A. If both (A) and (R) are true and (R) is the correct explanation of (A)
- B. if both (A) and (R) are true but (R) is not correct explanation of (A)

C. If (A) is true but (R) is false

D. If (A) is false but (R) is false

Answer: C

 [Watch Video Solution](#)

15. Assertion : Silicons are very inert polymers

Reason: Both $Si - O$ and $Si - C$ bond energies are very high

A. If both (A) and (R) are true and (R) is the correct explanation of (A)

B. if both (A) and (R) are true but (R) is not correct explanation of (A)

C. If (A) is true but (R) is false

D. If (A) is false but (R) is false

Answer: A

 [Watch Video Solution](#)

16. Assertion: AgI does not dissolve in NH_3 .

Reason: Due to ionic character of AgI.

- A. If both (A) and (R) are true and (R) is the correct explanation of (A)
- B. if both (A) and (R) are true but (R) is not correct explanation of (A)
- C. If (A) is true but (R) is false
- D. If (A) is false but (R) is false

Answer: C



Watch Video Solution

17. Assertion: Anhydrous $AlCl_3$ is covalent while hydrated $AlCl_3$ is ionic.

Reason: In water $AlCl_3$ is present as $Al_{(aq.)}^{3+}$ and $Cl_{(aq.)}^-$ ion.

- A. If both (A) and (R) are true and (R) is the correct explanation of (A)
- B. if both (A) and (R) are true but (R) is not correct explanation of (A)
- C. If (A) is true but (R) is false

D. If (A) is false but (R) is false

Answer: B::C

 [Watch Video Solution](#)

18. Assertion: Boron reacts with HNO_3

Reason: Boron reacts with all acids.

A. If both (A) and (R) are true and (R) is the correct explanation of (A)

B. if both (A) and (R) are true but (R) is not correct explanation of (A)

C. If (A) is true but (R) is false

D. If (A) is false but (R) is false

Answer: C

 [Watch Video Solution](#)

19. Assertion: H_2SO_4 is a weaker acid than $HClO_4$.

Reason: SO_4^{2-} is more stable than ClO_4^- in solution.

- A. If both (A) and (R) are true and (R) is the correct explanation of (A)
- B. if both (A) and (R) are true but (R) is not correct explanation of (A)
- C. If (A) is true but (R) is false
- D. If (A) is false but (R) is false

Answer: C



Watch Video Solution

20. Assertion: HF forms two series of salts but HCl not.

Reason: F -atom is more electronegative than Cl -atom.

- A. If both (A) and (R) are true and (R) is the correct explanation of (A)
- B. if both (A) and (R) are true but (R) is not correct explanation of (A)
- C. If (A) is true but (R) is false

D. If (A) is false but (R) is false

Answer: A

 Watch Video Solution

21. Assertion: PCl_3 on hydrolysis gives $OH - \overset{\overset{O}{||}}{P} - OH$ and not $OH - \underset{\underset{OH}{|}}{P} - OH$ as major product.

Reason: H_3PO_3 exists in two tautomeric forms

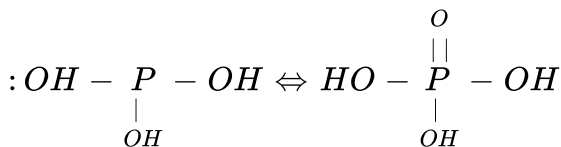

A. If both (A) and (R) are true and (R) is the correct explanation of (A)

B. if both (A) and (R) are true but (R) is not correct explanation of (A)

C. If (A) is true but (R) is false

D. If (A) is false but (R) is false

Answer: A



Watch Video Solution

22. Assertion: SnO is more reactive towards acid than SnO_2 .

Reason: Both SnO and SnO_2 are amphoteric oxides.

- A. If both (A) and (R) are true and (R) is the correct explanation of (A)
- B. if both (A) and (R) are true but (R) is not correct explanation of (A)
- C. If (A) is true but (R) is false
- D. If (A) is false but (R) is false

Answer: C



Watch Video Solution

23. Assertion: Bond dissociation energy of F_2 molecule is less than that of Cl_2 molecule.

Reason: Due to inter-electronic repulsion between F atom, F-F bond length in F_2 molecule is higher than Cl-Cl bond length in Cl_2 molecule.

- A. If both (A) and (R) are true and (R) is the correct explanation of (A)
- B. if both (A) and (R) are true but (R) is not correct explanation of (A)
- C. If (A) is true but (R) is false
- D. If (A) is false but (R) is false

Answer: A

 [Watch Video Solution](#)

24. Assertion: In H_3PO_3 basicity of the oxy acid is two.

Reason: One H-atom is non-ionizable in more stable tautomeric form of H_3PO_3 .

- A. If both (A) and (R) are true and (R) is the correct explanation of (A)
- B. if both (A) and (R) are true but (R) is not correct explanation of (A)
- C. If (A) is true but (R) is false
- D. If (A) is false but (R) is false

Answer: A

 [Watch Video Solution](#)

Subjective Problems

1. In phosphorus acid, If X is number of non-bonding electron pairs. Y is number of σ -bonds and Z is number of π -bonds. Then calculate value of "YxZ-X".

 [Watch Video Solution](#)

2. Consider the following oxyanions:

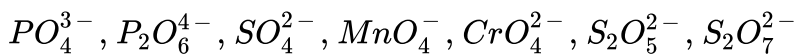

and find the value of R+Q-P

where P-number of oxy anions having three equivalent X-O bonds per central atom

Q=number of oxy anions having two equivalent X-O bonds per central

atom.

R=Number of oxy anions having four equivalent X-O bonds per central atom.

 [Watch Video Solution](#)

3. For oxyacid $HClO_x$, if $x=y=z$ (x, y and z are natural numbers), then calculate the value of $|x+y+z|$. Where x =number of 'O' atoms

y =total number of lone pairs at central atom

z =total number of pi(π) electrons in the oxyacid.

 [Watch Video Solution](#)

4. Consider the following representation of oxy-acid, $H_{n_1}S_2O_{n_2}$, (where S is central sulphur atom and n_1 and n_2 are natural numbers.) if there are two possible oxy-acid of sulphur A and B contains ratio of $n_2 : n_1$ are 2 and 4 respectively, then sum of oxidation state of 'S' atom in both oxy-acid will be:

 [Watch Video Solution](#)

 Watch Video Solution

5. total number of molecule which hydrolysed at room temperature and hybridization of central atom is sp^3d in transition state:

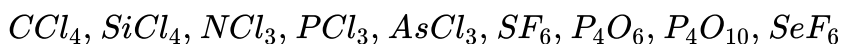

 Watch Video Solution

6. The difference between total number of lone pairs and total number of σ -bonds in $[B_3O_3(OH)_6]^{3-}$ molecular ion is:

 Watch Video Solution

7. Calculate vlaue of $|x + y - z|$ for the followng sillicate $[Si_xO_{y+z}]^{z-}$ anion.

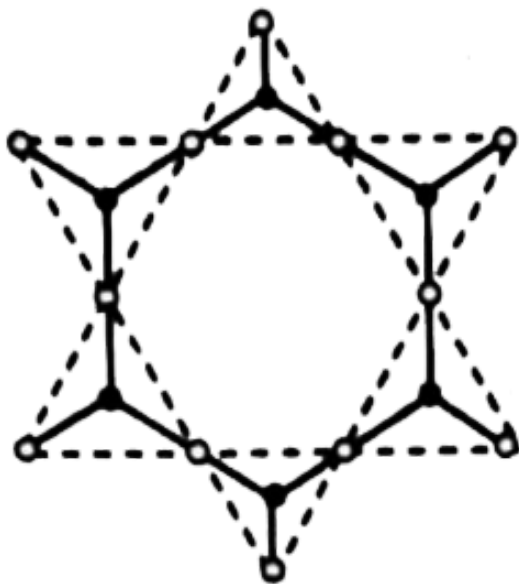

[Watch Video Solution](#)

8. The general formula of polythionate ion is $S_{n+2}O_6^{2-}$. If average oxidation state of 'S' atom in any polythionate ion is equal to bond order of 'S-O' bond. Then calculate the value of 'n' for the corresponding polythionate ion.

[Watch Video Solution](#)

9. total number of Boron atoms in anionic part of borax which participate in back bonding.

 [Watch Video Solution](#)

10. Choose total number of correct reaction.

(i) When $CuSO_4$ solution reacts with NH_3 , complex is formed.

(ii) When $CuSO_4$ solution react with PH_3 , complex is formed.

(iii) $C_{12}H_{22}O_{11} \xrightarrow{\text{conc. } H_2SO_4} 2C + 11H_2O$

(iv) $NH_3 + Cl_2 \xrightarrow{\Delta} NH_4Cl + N_2$
(excess)

 [Watch Video Solution](#)

11. Consider the following orders:

(1) $H_2SO_4 > H_2SO_3$: boiling point

(2) $H_2O > HF$: Extent of H-bond

(3) $H_2O < H_2O_2$: Strength off H-bond.



[Watch Video Solution](#)

12. How many monovalent oxygen atoms are present in the mineral kinoite

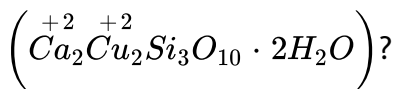

[Watch Video Solution](#)

13. How many moles of given compound are decomposed in the following decomposition reaction?

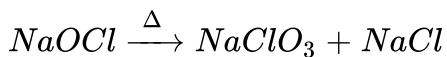

[Watch Video Solution](#)

14. How many moles of NaOH are required to react with one mole of solid

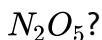

[Watch Video Solution](#)

15. How many moles of hypophosphorous acid are involved in its thermal decomposition reaction when one mole of each product is formed.

 [Watch Video Solution](#)

16. Consider the structure of Al_2Me_6 compound and find the value of $\frac{x - y}{z}$ where $x =$ maximum number of atoms that can lie in plane having terminal ($Al - Me$) bonds

$y =$ total number of $3c - 2e^-$ bonds

$z =$ total number of atoms that are sp^3 hybridized.

 [Watch Video Solution](#)

17. Sum of oxidation state of nitrogen atom in hyponitrous acid, nitric acid and nitrous acid.

 [Watch Video Solution](#)

18. Find the value of x in the tremolite asbestos:

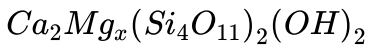

Watch Video Solution

19. Consider the following silicates

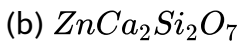
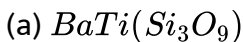

Then calculate $X+Y$, where X and Y are total number of monovalent and divalent oxygen atoms in both silicates respectively.



Watch Video Solution

20. Atomicity of white or yellow phosphorus is 4 and it is represented as

P_4 molecule.

calculate the value of expression $\frac{X \cdot Y}{Z}$ regarding this molecule.

Where: X : total number of vertex angles in P_4 molecule.

Y: Total number of lone pairs in P_4 molecule.

Z: total number of P-P bonds in P_4 molecule.

 [Watch Video Solution](#)

21. Marshall's acid $\xrightarrow{H_2O} A + B$

$A \xrightarrow{H_2O} B + C$

If P and Q represent maximum number of atoms that can lie in a plane of compound A and C respectively. Then, find out value of (P-Q).

 [Watch Video Solution](#)

22. Consider following four compounds:

(i) C_xO_y

(ii) C_xO_{y+1}

(iii) $C_{x+2}O_{y+1}$ and (iv) $C_{x+11}O_{y+8}$,

if " $x=y=1$ ", then calculate the value of $|p-q|$, where p and q are total number of sp^2 and hybridized carbon atoms respectively in given four compounds.



Watch Video Solution

23. If following molecules undergo dimerisation then find the value of

$$\frac{YZ}{X} :$$

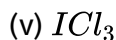
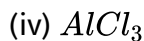
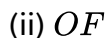

Where X=Number of molecules which are hypervalent in dimeric form.

Y=Number of molecules which complete octet in dimer form

Z=Number of molecules which are hypovalent in dimeric form.



Watch Video Solution

24. Consider $Al_2(OH)_6$ compound and calculate the value of $(X + Y) + Z$ Where X =total number of $(2c - 2e^-)$ bond.

Y =total number of $(3c - 2e^-)$ bond.

Z =total number of $(3c - 4e^-)$ bond



Watch Video Solution

25. Consider the following covalent compounds in their solid state and find the value of expression $(X + Y + Z)$.

$N_2O_5, Cl_2O_6, PCl, I_2Cl_6, XeF_6, PBr_5$

Where X =total number of compounds in which central atom of cationic or anionic part is sp^3 hybridized.

Y =Total number of compounds having 90° bond angle either in cationic or anionic part.

Z =Total number of compounds having $109^\circ 28'$ bond angle either in cationic or anionic part.



Watch Video Solution

26. Consider following compounds A to E :

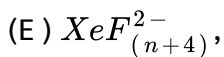
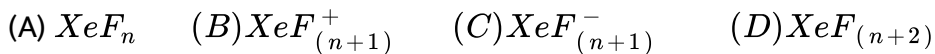

If value of n is 4, then calculate value of $p \div q$ here, 'p' is total number of bond pair and 'q' is total number of lone pair on central atoms of compounds (A) to (E).

 [Watch Video Solution](#)

27. What is covalency of chlorine atom in second excited state ?

 [Watch Video Solution](#)

28. Consider the following

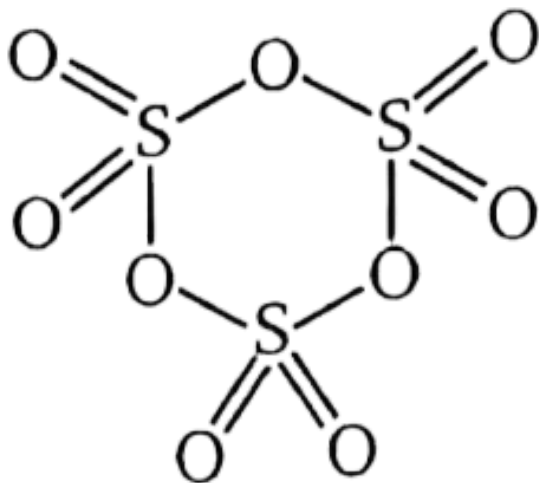

Calculate value of $p + q$, here p and q are total number of $d\pi - p\pi$ bonds and total number of sp^3 hybridised atoms respectively in given molecule.

 [Watch Video Solution](#)

29. Consider the following structures and calculate value of $(P^2 - Q^2)$

Where P = total number of correct structure representation.

Q=Total number of incorrect structure representation.

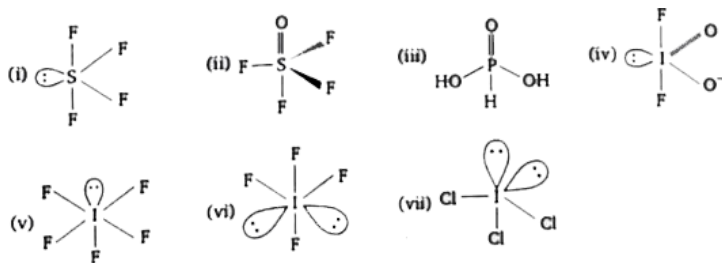

[Watch Video Solution](#)

30. Calculate the value of " $x+y-z$ " here x , y and z are total number of non-bonded electron pair (s), pie (π) bond(s) and sigma (σ) bonds in hydrogen phosphite ion respectively.

[Watch Video Solution](#)

31. Consider the following species:

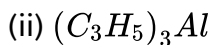
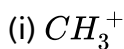

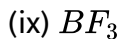
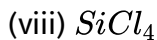
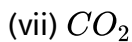
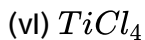
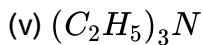
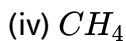

the find out total number of species which can act as Lewis acid.



[Watch Video Solution](#)

32. Consider the following species:

CF_4 , GeH_4 , BCl_3 , $AlBr_3$, H_2O , PH_3 , PCl_5 , CO_2 , CH_4 and calculate

value of $(x - y)^2$:

Where, x: Total number of species which can act as only lewis acid.

y: total number of species which can act as lewis acid as well as lewis base.



[Watch Video Solution](#)

33. If X, Y and Z are total number of π -bond(s) in $H_2S_2O_6, H_2SO_3$ and $H_2S_2O_7$ respectively then calculate value of expression $|X + Y - Z|$.

 [Watch Video Solution](#)

34. Calculate value of " $x+y$ " for "hypophosphoric acid", where x is total number of lone pair(s) and y is total number π -bond(s) in given oxo-acids.

 [Watch Video Solution](#)

35. Atomicity of white or yellow phosphorus is 4 and it is represented as P_4 molecule

Calculate the value of expression $\frac{x \cdot y}{z}$ regarding this molecule.

Where x : total number of vertex angles in P_4 molecule.

y : Total number of lone pairs in P_4 molecule

z : total number of P-P bonds in P_4 molecule.

 [Watch Video Solution](#)



Watch Video Solution