



PHYSICS

BOOKS - HC VERMA PHYSICS (ENGLISH)

FRICITION

Example

1. The body of mass 400 g slides on a rough horizontal surface. If the frictional force is 3.0 N, find a. the angle made by the contact force on the body with the vertical and b. the magnitude of the contact force. Take $g = 10 \frac{m}{s^2}$



Watch Video Solution

2. A heavy box of mass 20 kg is placed on a horizontal surface . If coefficient of kinetic friction between the box and the horizontal surface is 0.25, calculate the force of kinetic friction Also calculate acceleration produced under a force of 98 N applied horizontally ?

 [Watch Video Solution](#)

3. A boy (30 kg) sitting on his horse whips it. The horse speeds up at an average acceleration of $2.0 \frac{m}{s^2}$. A. If the boy does not slide back, what is the force of friction exerted by the horse on the boy? b.If the boy slides back during the acceleration, what can be said about the coefficient of static friction between the horse and the boy. Take $g = 10 \frac{m}{s^2}$

 [Watch Video Solution](#)

4. A wooden block is kept on a polished wooden plank and the inclination of the plank is gradually increased. It is found that the block starts slipping when the plank makes an angle of 18° with the horizontal. However, once started the block can continue with uniform speed if the inclination is reduced to 15° . Find the coefficients of static and kinetic friction between the block and the plank.

 [Watch Video Solution](#)

Worked Out Examples

1. The coefficient of static friction between a block of mass m and an incline is $\mu_s = 0.3$, a. What can be the maximum angle θ of the incline with the horizontal so that the block does not slip on the plane? b. If the incline makes an angle $\frac{\theta}{2}$ with the horizontal, find the frictional force on the block.

 [Watch Video Solution](#)

2. A horizontal force of 20 N is applied to a block of mass 4 kg resting on a rough horizontal table. If the block does not move on the table, how much frictional force the table is applying on the block. What can be said about the coefficient of static friction between the block and the table? $Take g = 10 \frac{m}{s^2}$.

 [Watch Video Solution](#)

3. The coefficient of static friction between the block of 2 kg and the table shown in figure is $\mu_s = 0.2$. What should be the maximum value of m so that the blocks do not move? Take $g = 10 \frac{m}{s^2}$. The string and the pulley are light and smooth.

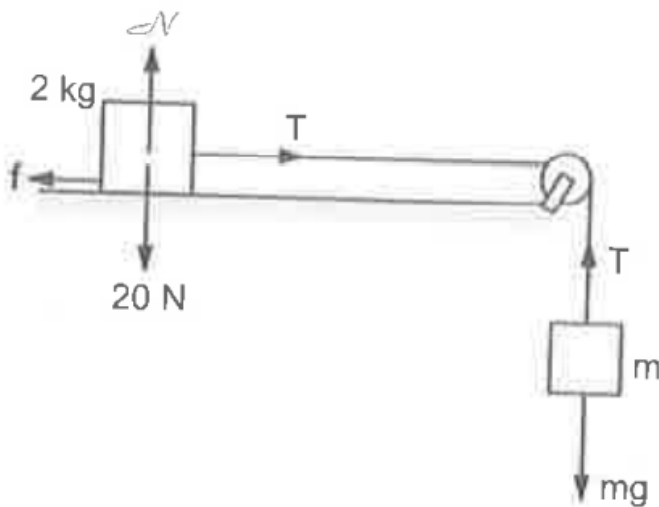

Figure 6-W3



Watch Video Solution

4. The coefficient of static friction between the two blocks shown in figure is μ and the table is smooth. What maximum horizontal force F can be applied to the block of mass M so that the blocks move together?

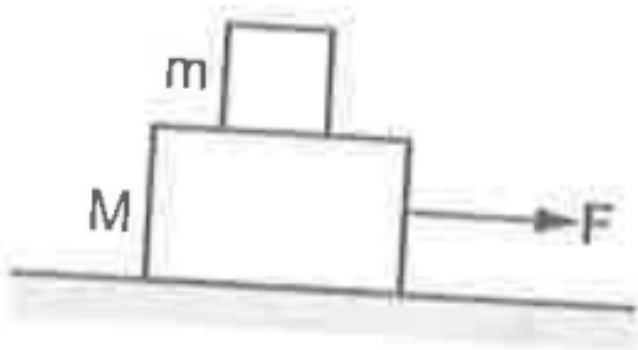

Figure 6-W4

[▶ Watch Video Solution](#)

5. A block slides down an incline of angle 30° with an acceleration $g/4$. Find the kinetic friction coefficient.

 [Watch Video Solution](#)

6. A block of mass 2.5 kg is kept on a rough horizontal surface. It is found that the block does not slide if a horizontal force less than 15 N is applied to it. Also it is found that it takes 5 seconds to slide through the first 10 m if a horizontal force of 15 N is applied and the block is gently pushed to start the motion. Taking $g = 10 \frac{m}{s^2}$, calculate the coefficient of static and kinetic friction between the block and the surface.

 [Watch Video Solution](#)

7. A block placed on a horizontal surface is being pushed by a force F making an angle θ with the vertical. If the friction

coefficient is μ . How much force is needed to get the block just started. Discuss the situation when $\tan \theta < \mu$.

[▶ Watch Video Solution](#)

8. Find the maximum value of M/m in the situation shown in figure so that the system remains at rest. Friction coefficient at both the contacts μ . Discuss the situation when $\tan \theta > \mu$

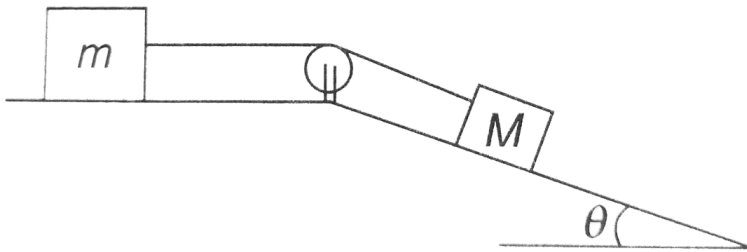

[▶ Watch Video Solution](#)

9. Consider the situation shown in figure. The horizontal surface below the bigger block is smooth. The coefficient of friction between the blocks is μ . Find the minimum and the maximum force F that can be applied in order to keep the smaller block at rest with respect to the bigger block.

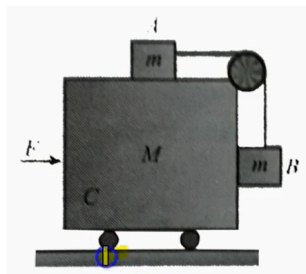

Watch Video Solution

10. figure shows two blocks connected by a light string placed on the two inclined parts of a triangular structure. The coefficients of static and inetic friction are 0.28 and 0.25

respectively at each of the surface. a. Find the minimum and maximum values of m for which the system remains at rest, b. Find the acceleration of either block if m is given the minimum value calculated in the first part and is gently pushed up the incline for a short while.

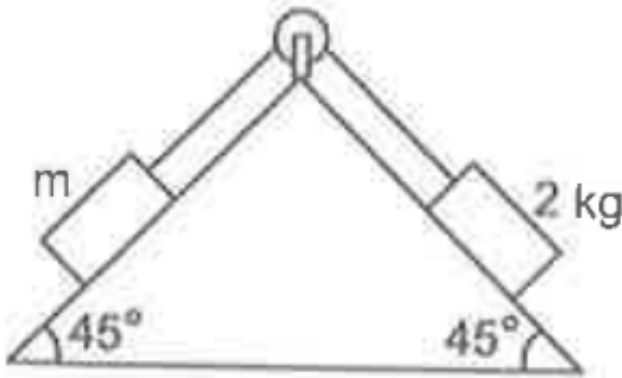

Figure 6-W15

[View Text Solution](#)

Objective 1

1. In a situation the contact force by a rough horizontal surface on a body placed on it has constant magnitude. If the angle between this force and the vertical is decreased, the frictional force between the surface and the body will

- A. increase
- B. decrease
- C. remain the same
- D. may increase or decrease

Answer: B



Watch Video Solution

2. To avoid slipping while walking on ice, one should take smaller steps because of the

- A. larger friction
- B. smaller friction
- C. larger normal force
- D. smaller normal force

Answer: B



Watch Video Solution

3. A body of mass M is kept on a rough horizontal surface (friction coefficient $=\mu$). A person is trying to pull the body by applying a horizontal force but the body is not moving.

The force by the horizontal surface on the surface of the body is F , where

A. $F = mg$

B. $F = \mu Mg$

C. $Mg \leq F \leq Mg\sqrt{1 + \mu^2}$

D. $Mg \geq F \geq Mg\sqrt{1 - \mu^2}$

Answer: C



Watch Video Solution

4. A scooter starting from rest moves with a constant acceleration for a time Δt_1 , then with a constant velocity for the next Δt_2 and finally with a constant deceleration

for the next Δt_3 to come to rest with respect to the scooter without touching any other part. The force exerted by the seat on the man is

- A. 500 N throughout the journey
- B. less than 500 N throughout the journey
- C. more than 500 N throughout the journey
- D.

$> 500Nf$ or *time* Δ_1 and Δ_3 and $500Nf$ or Δt_2

.

Answer: D



Watch Video Solution

5. Consider the situation shown in figure. The wall is smooth but the surfaces of A and B in contact are rough. The friction on B due to A in equilibrium.

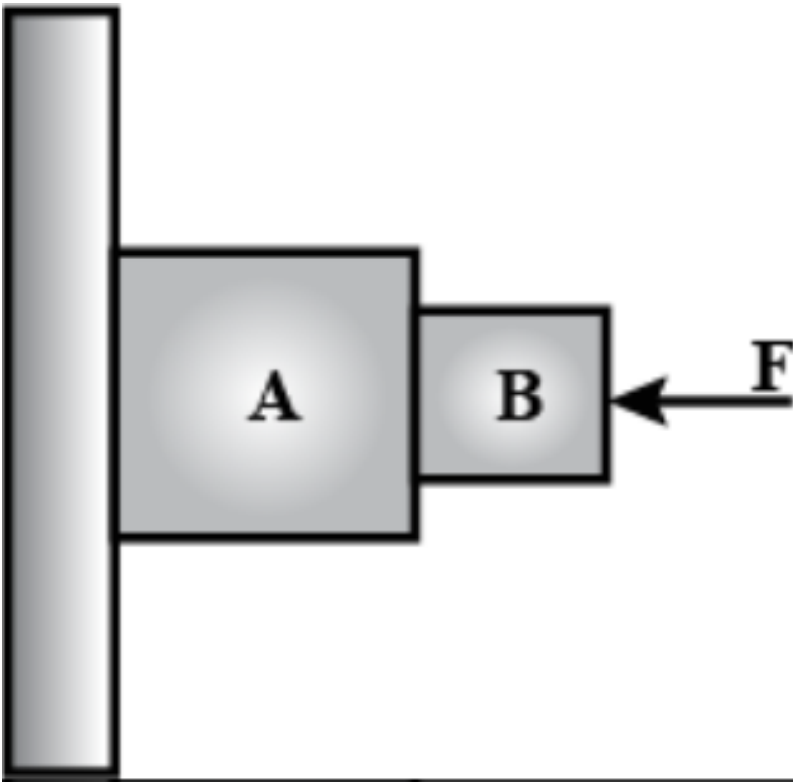

A. is upward

B. is downward

C. is zero

D. the system cannot remain in equilibrium

Answer: D



Watch Video Solution

6. Suppose all the surfaces in the previous problem are rough. The direction of friction on B due to A

A. is upward

B. is downward

C. is zero

D. depends on the masses of A and B

Answer: A



Watch Video Solution



[Watch Video Solution](#)

7. Two cars of unequal masses use similar tyres. If they are moving at the same initial speed, the minimum stopping distance

- A. is smaller for the heavier
- B. is smaller for the lighter car
- C. is same for both cars
- D. depends on the volume of the car

Answer: C



[Watch Video Solution](#)

8. In order to stop a car in shortest distance on a horizontal road one should

A. apply the brakes very hard so that the wheels stop rotating

B. apply the brakes heard enough to just prevent slipping

C. pump the brakes (press and release)

D. shut the engine of and not apply brakes

Answer: B



Watch Video Solution

9. A block A kept on an inclined surface just begins to slide if the inclination is 30° . The block is replaced by another block B and it is found that it just begins to slide if the inclination is 40°

- A. mass of A > mass of B
- B. mass of A < mass of B
- C. mass of A = mass of B
- D. all the three are possible.

Answer: D



Watch Video Solution

10. A boy of mass M is applying a horizontal force to slide a box of mass M on a rough horizontal surface. The coefficient of friction between the floor and the box is μ and the coefficient of friction between the boy and the floor is μ' . In which of the following cases it is certainly not possible to slide the box?

A. $\mu < \mu', M < M'$

B. $\mu > \mu', M < M'$

C. $\mu < \mu', M > M'$

D. $\mu > \mu', M > M'$

Answer: A



Watch Video Solution

Objective 2

1. Let F , F_N and f denote the magnitudes of the contact force, normal force and the friction exerted by one surface on the other kept in contact. If none of these is zero,

A. $F > F_N$

B. $F > 1$

C. $F_N > f$

D. $F_N - f < F < F_N + f$.

Answer: A::B::D



Watch Video Solution

2. The contact force exerted by a body A on another body B is equal to the normal force between the bodies. We conclude that

A. the surface must be frictionless

B. the force of friction between the bodies is zero

C. the magnitude of normal force equals that of friction

D. the bodies may be rough but they don't slip on each other.

Answer: B::D



Watch Video Solution

3. Mark the correct statements about the friction between two bodies

A. static friction is always greater than the kinetic friction.

B. coefficient of static friction is always greater than the coefficient of kinetic friction

C. Limiting friction is always greater than the kinetic friction

D. Limiting friction never less than static friction.

Answer: B::C::D



Watch Video Solution

4. A block is placed on a rough floor and a horizontal force F is applied on it. The force of friction f by the floor on the block is measured for different values of F and a graph is plotted between them.

- A. The graph is a straight line of slope 45°
- B. The graph is a straight line parallel to the F -axis
- C. The graph is a straight line of slope 45° for small F and a straight line parallel to the F -axis for large F .
- D. There is a small kink on the graph

Answer: C::D



Watch Video Solution

5. Consider a vehicle going on a horizontal road towards east. Neglect any force by the air. The frictional forces on the vehicle by the road

- A. is towards east if the vehicle is accelerationg
- B. is zero if the vehicle is moving with a uniform velocity
- C. must be towards east
- D. must be towards west

Answer: A::B

 [Watch Video Solution](#)

1. A body slipping on a rough horizontal plane moves with a deceleration of $4.0 \frac{m}{s}$. What is coefficient of kinetic friction between the block and the plane?

 [Watch Video Solution](#)

2. A block is projected along a rough horizontal road with a speed of 10 m/s. If the coefficient of kinetic friction is 0.10, how far will it travel before coming to rest?

 [Watch Video Solution](#)

3. A block of mass m is kept on a horizontal table. If the static friction coefficient is μ_s , find the frictional force acting on the block.

 [Watch Video Solution](#)

4. A block slides down an inclined surface of inclination 30° with the horizontal. Starting from rest it covers 8 m in the first two seconds. Find the coefficient of kinetic friction between the two.

 [Watch Video Solution](#)

5. Suppose the block of the previous problem is pushed down the incline with a force of 4N. How far will the block move in the first two seconds after starting from rest? The mass of the block is 4 kg.

 [Watch Video Solution](#)

6. A body of mass 2 kg is lying on rough inclined plane of inclination 30° . Find the magnitude of the force parallel to the incline needed to make the block move a. up the incline b. down the incline. Coefficient of static friction = 0.2

 [Watch Video Solution](#)

7. A body of mass 2 kg is lying on rough inclined plane of inclination 30 degree . Find the magnitude of the force parallel to the incline needed to make the block move a. up the incline b. down the incline. Coefficient of static friction = 0.2

Repeat part a. of problem 6 if the push is applied horizontally and not parallel to the incline.

 [Watch Video Solution](#)

8. In a children park an inclined plane is constructed with an angle of incline 45° in the middle part figure. Find the acceleration of a boy sliding on it if the friction coefficient between the cloth of the boy and the incline is 0.6 and $g = 10 \frac{m}{s^2}$.

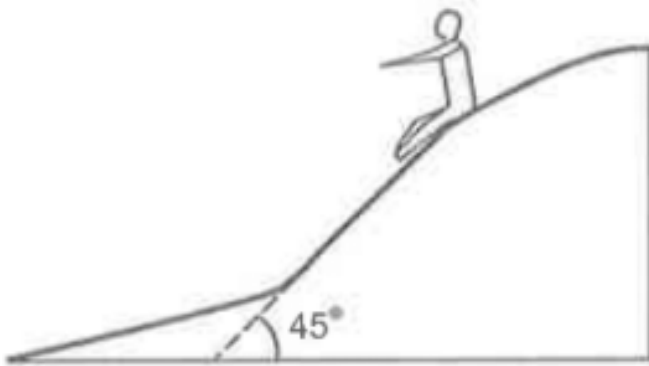

[▶ Watch Video Solution](#)

9. A body starts slipping down an incline and moves half meter in half second. How long will it take to move the next half meter?

 [Watch Video Solution](#)

10. The angle between the resultant contact force and the normal force exerted by a body on the other is called the angle of friction. Show that it λ be the angle of friction and μ the coefficient of static friction. $\lambda \leq \tan^{-1} \mu$.

 [Watch Video Solution](#)

11. Consider the situation shown in figure. Calculate a. the acceleration of the 1.0 kg blocks, b. the tension in the string connecting the 1.0 kg blocks and c. the tension in the string attached to 0.50 kg.

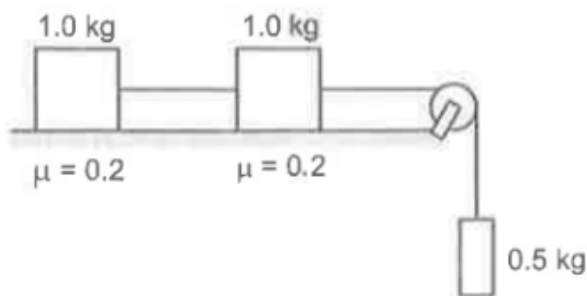

[Watch Video Solution](#)

12. If the tension in the string in the figure is N and the acceleration of each block is $0.5 \frac{m}{s^2}$, find the friction

coefficients at the two contacts with h blocks.

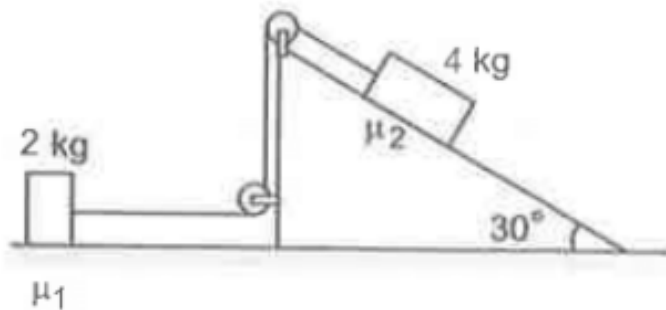

[View Text Solution](#)

13. The friction coefficient between the table and the block shown in figure is 0.2. Find the tension in the two strings.



[View Text Solution](#)

14. The friction coefficient between a road and the tyre of a vehicle is $\frac{4}{3}$. Find the maximum incline the road may have so that once hard brakes are applied and the wheel starts skidding, the vehicle going down at a speed of 36 km/hr is stopped within 5m.



Watch Video Solution

15. The friction coefficient between an athlete's shoes and the ground is 0.90. Suppose a superman wears these shoes and races for 50 m. There is no upper limit in his capacity of running at high speeds. A. Find the minimum time that he will have to take in completing the 50 m starting from rest.
b. Suppose he takes exactly this minimum time to complete the 50 m, what minimum time will he take to stop?



Watch Video Solution

16. A car is going at a speed of 21.6 km/hr when it encounters a 12.8 m long slope of angle 30° figure. $\frac{1}{2\sqrt{3}}$.

Show that no matter how hard the driver applies the brakes, the car will reach the bottom with a speed greater than 36 km/hr. Take $g = 10 \frac{m}{s^2}$



Watch Video Solution

17. A car starts from rest on a half kilometer long bridge. The coefficient of friction between the tyre and the road is 1.0. Show that one cannot drive through the bridge in less than 10 s.



[Watch Video Solution](#)

18. Figure shows two blocks in contact sliding down an inclined surface of inclination 30° . The friction coefficient between the block of mass 2.0 kg and the incline is μ_1 and that between the block of mass 4.0 kg and the incline is μ_2 . Calculate the acceleration of the 2.0 kg block if a. $\mu_1 = 0.20$ and $\mu_2 = 0.30$ b. $\mu_1 = 0.30$ and $\mu_2 = 0.20$.

Take $g = 10\frac{\text{m}}{\text{s}^2}$.



[View Text Solution](#)

19. Two masses M_1 and M_2 are connected by a light rod and the system is slipping down a rough incline of angle θ

with the horizontal. The friction coefficient at both the contacts is μ . Find the acceleration of the system, and the force by the rod on one of the blocks.

 [Watch Video Solution](#)

20. A block of mass M is kept on a rough horizontal surface. The coefficient of static friction between the block and the surface is μ . The block is to be pulled by applying a force to it. What minimum force is needed to slide the block? In which direction should this force act?

 [Watch Video Solution](#)

21. The friction coefficient between the board and the floor shown in figure is μ . Find the maximum force that the man can exert on the rope so that the board does not slip on the floor.



 [Watch Video Solution](#)

22. A 2 kg block is placed over a 4 kg block and both are placed on a smooth horizontal surface. The coefficient of friction between the blocks is 0.20. Find the acceleration of the two blocks if a horizontal force of 12 N is applied to a. the upper block, b. the lower block. Take $g = 10 \frac{m}{s^2}$.

 [Watch Video Solution](#)

23. Find the accelerations a_1, a_2, a_3 of the three blocks shown in figure if a horizontal force of 10 N is applied on a. 2 kg block, b. 3 kg block, c. 7 kg block. Take $g = 10 \frac{m}{s^2}$.

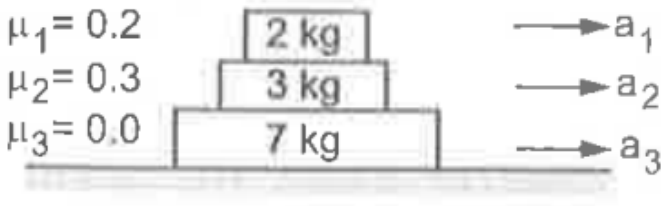

Figure 6-E8

[View Text Solution](#)

24. The friction coefficient between the two blocks shown in figure is μ but the floor is smooth. A. What maximum horizontal force F can be applied without disturbing the equilibrium of the system? b. suppose the horizontal force

applied is double of that found in part a. Find the accelerations of the two masses.

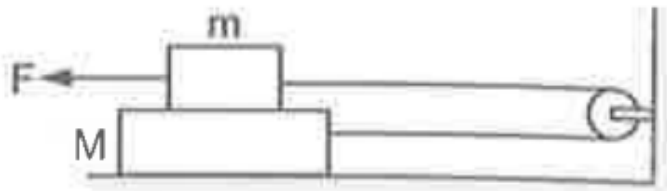

Figure 6-E9

[▶ Watch Video Solution](#)

25. Suppose the entire system of the previous question is kept inside an elevator which is coming down with an acceleration atg . Repeat parts a. and b.

[▶ View Text Solution](#)

26. Consider the situation shown in figure. Suppose a small electric field E exists in the space in the vertically upward direction and the upper block carries a positive charge Q on its top surface. The friction coefficient between the two blocks is μ but the floor is smooth. What maximum horizontal force F can be applied without disturbing the equilibrium?

 [View Text Solution](#)

27. A block of mass m is stationary on a rough inclined plane making an angle θ with the horizontal. Find the contact force between block and the plane

 [Watch Video Solution](#)

28. Find the acceleration of the block of mass M in the situation of figure. The coefficient of friction between the two blocks is μ_1 and that between the bigger block and the ground is μ_2 .

 [View Text Solution](#)

29. A block of mass 2 kg is pushed against a rough vertical wall with a force of 40 N . Coefficient of static friction being 0.5 . Another horizontal force of 15 N , is applied on the block in a direction parallel to the wall. Will the block move? If yes in which direction? If no, find the frictional force exerted by the wall on the block.

 [Watch Video Solution](#)

30. A person (40 kg) is managing to be at rest between two vertical walls by pressing one wall A by his hands and feet and the other wall B by his back figure. Assume that the friction coefficient between his body and the walls is 0.8 and that limiting friction acts at all the contacts. a. show that the person pushes the two walls with equal force. b. find the normal force exerted by either wall on the person. Take

$$g = 10 \frac{m}{s^2}.$$

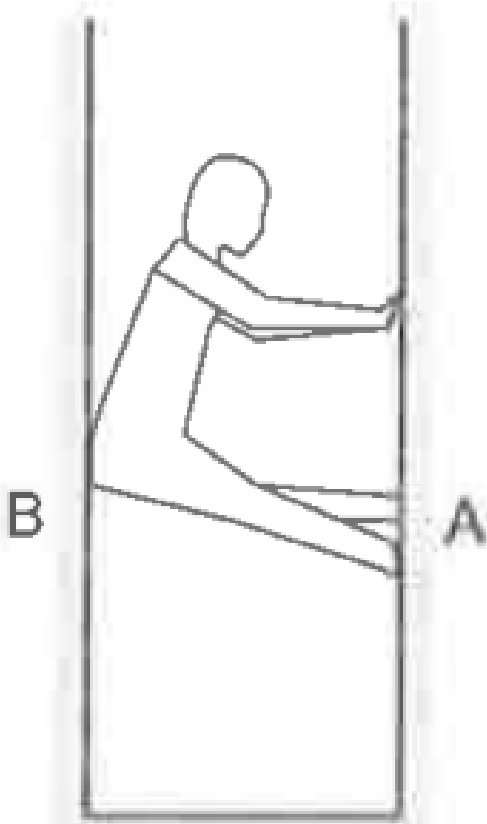

Figure 6-E11



Watch Video Solution

31. Figure shows a small block of mass m kept at the left end of a larger block of mass M and length l . The system can slide on a horizontal road. The system is started towards right with an initial velocity v . The friction coefficient between the road and the bigger block is μ and that between the blocks is $\frac{\mu}{2}$. Find the time elapsed before the smaller block separates from the bigger block.



Figure 6-E12



[View Text Solution](#)

Questions For Short Answer

1. For most of the surfaces used in daily life, the friction coefficient is less than 1. Is it always necessary that the friction coefficient is less than 1?

 [Watch Video Solution](#)

2. Why is it easier to push a heavy block from behind than to press it on the top and push?

 [Watch Video Solution](#)

3. What is the average friction force when a person has a usual 1 km walk?



[Watch Video Solution](#)

4. Why is it difficult to walk on solid ice?



[Watch Video Solution](#)

5. Can you accelerate a car on a frictionless horizontal road by putting more petrol in the engine? Can you stop a car going on a frictionless horizontal road by applying brakes?



[Watch Video Solution](#)

6. Spring fitted doors close by themselves when released. You want to keep the door open for a long time, say for an

hour. If you put a half kg stone in front of the open door, it does not help. The stone slides with the door and the door gets closed. However, if you sandwich a 20 g of wood in the small gap between the door and the floor, the door stays open. Explain why a much lighter piece of wood is able to keep the door open while the heavy fails.



[Watch Video Solution](#)

7. A classroom demonstration of Newton's first law is as follows: A glass is covered with a plastic card and a coin is placed on the card. The card is given a quick strike and the coin falls in the glass. a. Should the friction coefficient between the card and the coin be small or large? b. Should the coin be light or heavy? c. Why does the experiment fail if the card is gently pushed?



[Watch Video Solution](#)

8. Can a tug of war be ever won on a frictionless surface?



[Watch Video Solution](#)

9. Why do tyres have a better griop of the road while going on a level road than while going on an incline?



[Watch Video Solution](#)

10. You are standing with your bag in your handsd, on the ice n the middle of a pond. The ice is so slippery that it can offer no fricton. How can you come out of the ice?

 [Watch Video Solution](#)

11. When two surface are polished, the friction coefficient between them decreases. But the friction coefficient increases and becomes very large if the surfaces are made highly smooth. Explain.

 [Watch Video Solution](#)