



MATHS

BOOKS - FULL MARKS MATHS (TAMIL ENGLISH)

SAMPLE PAPER -12

Part I

1. If $A = \begin{bmatrix} 3 & 5 \\ 1 & 2 \end{bmatrix}$, $B = \text{adj}A$ and $C = 3A$, then $\frac{|\text{adj}B|}{|C|} = \dots\dots$

A. $\frac{1}{3}$

B. $\frac{1}{9}$

C. $\frac{1}{4}$

D. 1

Answer: B



Watch Video Solution

2. If $\rho(A) \neq \rho([A \mid B])$, then the system is

- A. consistent and has infinitely many solution
- B. consistent and has unique solution
- C. consistent
- D. inconsistent

Answer: D



Watch Video Solution

3. The principal argument of $(\sin 40^\circ + i\cos 40^\circ)^5$ is

- A. -110°
- B. -70°

C. 70°

D. 110°

Answer: A



Watch Video Solution

4. Find the fourth roots of unity.

A. $1 \pm i, -1 \pm i$

B. $\pm i, 1 \pm i$

C. $\pm 1, \pm i$

D. 1,-1

Answer: D



Watch Video Solution

5. If α, β and γ are the zeros of $x^3 + px^2 + qx + r$, then $\Sigma \frac{1}{\alpha}$ is

A. $-\frac{q}{r}$

B. $-\frac{p}{r}$

C. $\frac{q}{r}$

D. $-\frac{q}{p}$

Answer: A



Watch Video Solution

6. If the function $f(x) = \sin^{-1}(x^2 - 3)$ then x belongs to

A. $[-1,1]$

B. $[\sqrt{2}, 2]$

C. $[-2, -\sqrt{2}] \cup [\sqrt{2}, 2]$

D. $[-2, -\sqrt{2}] \cap [\sqrt{2}, 2]$

Answer: C



Watch Video Solution

7. $\sin^{-1} x - \cos^{-1}(-x) = \dots\dots\dots$

A. $\frac{-\pi}{2}$

B. $\frac{\pi}{2}$

C. $\frac{-3\pi}{2}$

D. $\frac{3\pi}{2}$

Answer: A



Watch Video Solution

8. The ellipse $E_1: \frac{x^2}{9} + \frac{y^2}{4} = 1$ is inscribed in a rectangle R whose sides are parallel to the coordinate axes. Another ellipse E_2 passing through

the point (0,4) circumscribes the rectangle R. The eccentricity of the ellipse is

A. $\frac{\sqrt{2}}{2}$

B. $\frac{\sqrt{3}}{2}$

C. $\frac{1}{2}$

D. $\frac{3}{4}$

Answer: C



Watch Video Solution

9. The eccentricity of the hyperbola $\frac{y^2}{9} - \frac{x^2}{25} = 1$ is

A. $\frac{34}{3}$

B. $\frac{5}{3}$

C. $\frac{\sqrt{34}}{3}$

D. $\frac{\sqrt{34}}{5}$

Answer: C

 [Watch Video Solution](#)

10. If the area of the parallelogram having diagonals

$$\vec{a} = 3\hat{i} + \hat{j} - 2\hat{k}, \vec{b} = \hat{i} - 3\hat{j} + 4\hat{k} \text{ is :}$$

A. $10\sqrt{3}$

B. $6\sqrt{30}$

C. $\frac{3}{2}\sqrt{30}$

D. $3\sqrt{30}$

Answer: D

 [Watch Video Solution](#)

11. The function $\sin^4 x + \cos^4 x$ is increasing in the interval

A. $\left[\frac{5\pi}{8}, \frac{3\pi}{4} \right]$

B. $\left[\frac{\pi}{2}, \frac{5\pi}{8} \right]$

C. $\left[\frac{\pi}{4}, \frac{\pi}{2} \right]$

D. $\left[0, \frac{\pi}{4} \right]$

Answer: C



Watch Video Solution

12. The function $f(x) = x^3$ is

A. increasing

B. decreasing

C. strictly decreasing

D. strictly increasing

Answer: D



Watch Video Solution

13. If $g(x, y) = 3x^2 - 5y + 2y^2$, $x(t) = e^t$ and $y(t) = \cos t$, then $\frac{dg}{dt}$ is equal to

A. $6e^{2t} + 5 \sin t - 4 \cos t \sin t$

B. $6e^{2t} - 5 \sin t + 4 \cos t \sin t$

C. $3e^{2t} + 5 \sin t + 4 \cos t \sin t$

D. $3e^{2t} - 5 \sin t + 4 \cos t \sin t$

Answer: A

 Watch Video Solution

14. For the function $y = x^3 + 2x^2$ the value of dy when $x=2$ and $dx=0.1$ is

A. 1

B. 2

C. 3

D. 4

Answer: B

 [Watch Video Solution](#)

15. The value of $\int_0^0 (\sqrt{a^2 - x^2})^3 dx$ is

A. $\frac{\pi a^3}{16}$

B. $\frac{3\pi a^4}{16}$

C. $\frac{3\pi a^2}{8}$

D. $\frac{3\pi a^4}{8}$

Answer: B

 [View Text Solution](#)

16. If the solution of the differential equation $\frac{dy}{dx} = \frac{ax + 3}{2y + f}$ represents a circle, then the value of a is :

A. 2

B. -2

C. 1

D. -1

Answer: B



Watch Video Solution

17. The solution of $\frac{dy}{dx} + p(x)y = 0$ is

A. $y = ce^{\int P dx}$

B. $y = ce^{-\int P dx}$

C. $x = ce^{-\int P dy}$

$$D. x = ce^{\int Pdy}$$

Answer: B



Watch Video Solution

18. A random variable X has binomial distribution with $n=25$ and $p=0.8$ then standard deviation of X is

A. 6

B. 4

C. 3

D. 2

Answer: D



Watch Video Solution

19. A computer salesperson knows from his past experience that he sells computers to one in every twenty customers who enter the showroom. What is the probability that he will sell a computer to exactly two of the next three customers?

A. $\frac{57}{20^3}$

B. $\frac{57}{20^2}$

C. $\frac{19^3}{20^3}$

D. $\frac{57}{20}$

Answer: A



Watch Video Solution

20. The truth table for $(p \wedge q) \vee \neg q$ is given below:

p	q	$(p \wedge q) \vee (\neg q)$
T	T	(a)
T	F	(b)
F	T	(c)
F	F	(d)

Which of the following is true?

- A. (1) (a) (b) (c) (d)
 T T T T
- B. (2) (a) (b) (c) (d)
 T F T T
- C. (3) (a) (b) (c) (d)
 T T F T
- D. (4) (a) (b) (c) (d)
 T F F F

Answer: C



Watch Video Solution

1. Find the rank of each of the following matrices: $\begin{bmatrix} 3 & 2 & 5 \\ 1 & 1 & 2 \\ 3 & 3 & 6 \end{bmatrix}$

 [Watch Video Solution](#)

2. Simplify the following:

$$i \ i^2 \ i^3 \ \dots \ i^{2000}$$

 [Watch Video Solution](#)

3. Find the equation of the parabola. Focus (4,0) and directrix $x=-4$.

 [Watch Video Solution](#)

4. A plane passes through the point $(1, 1, 2)$ - and the normal to the plane of magnitude $3\sqrt{3}$ makes equal acute angles with the coordinate axes. Find the equation of the plane.

 [Watch Video Solution](#)

5. If the volume of a cube of side length x is $V = x^3$. Find the rate of change of the volume with respect to x when $x = 5$ units.

 [Watch Video Solution](#)

6. Use linear approximation to find an approximate value of $\sqrt{9.2}$ without using a calculator.

 [Watch Video Solution](#)

7. Evaluate the following :

$$\int_0^{\frac{\pi}{4}} \sin^6 2x dx$$

 [Watch Video Solution](#)

8. Find the differential equation for the family of all straight lines passing through the origin

 [Watch Video Solution](#)

9. $f(x) = \begin{cases} \frac{A}{x} & 1 < x < e^3 \\ 0 & \text{elsewhere} \end{cases}$ is a probability density function of a continuous random of X , find $P(x > e)$

 [Watch Video Solution](#)

10. Let $A = \begin{bmatrix} 0 & 1 \\ 1 & 1 \end{bmatrix}$, $B = \begin{bmatrix} 1 & 1 \\ 0 & 1 \end{bmatrix}$ be any two boolean matrices of the same type find $A \vee B$ and $A \wedge B$



[Watch Video Solution](#)

Part iii

1. Show that the points represented by the complex numbers $7 + 9i$, $-3 + 7i$, $3 + 3i$ form a right angled triangle on the Argand diagram.



[Watch Video Solution](#)

2. Prove that a straight line and parabola cannot intersect at more than two points.



[Watch Video Solution](#)

3. Find the value of $\cos\left(\cos^{-1}\left(\frac{4}{5}\right) + \sin^{-1}\left(\frac{4}{5}\right)\right)$

 [Watch Video Solution](#)

4. Determine whether the points $(-2,1)$, $(0,0)$ and $(-4,-3)$ lie outside, on or inside the circle $x^2 + y^2 - 5x + 2y - 5 = 0$

 [Watch Video Solution](#)

5. Prove that $\left[\vec{a} \times \vec{b}, \vec{b} \times \vec{c}, \vec{c} \times \vec{a}\right] = \left[\vec{a}, \vec{b}, \vec{c}\right]^2$

 [Watch Video Solution](#)

6. Find the intervals of monotonicity and local extrema of the function $f(x) = x \log x + 3x$

 [Watch Video Solution](#)

7. If $u(x, y) = \frac{x^2 + y^2}{\sqrt{x + y}}$, prove that $x \frac{\partial u}{\partial x} + y \frac{\partial u}{\partial y} = \frac{3}{2}u$.



[Watch Video Solution](#)

8. Four defective oranges are accidentally mixed with sixteen good ones. Two oranges are drawn at random from the mixed lot. If the random variable 'X' denotes the number of defective oranges, then find the values of 'X' and number of points in its inverse image.



[Watch Video Solution](#)

9. Show that $\neg(p \wedge q) \equiv ((\neg p) \vee (\neg q))$



[Watch Video Solution](#)

10. Find the rank of each of the following matrices: (i) $\begin{bmatrix} 3 & 2 & 5 \\ 1 & 1 & 2 \\ 3 & 3 & 6 \end{bmatrix}$ (ii)

$$\begin{bmatrix} 4 & 3 & 1 & -2 \\ -3 & -1 & -2 & 4 \\ 6 & 7 & -1 & 2 \end{bmatrix}$$

 [Watch Video Solution](#)

11. In a T20 match, Chennai Super Kings needed just 6 runs to win with 1 ball left to go in the last over. The last ball was bowled and the batsman at the crease hit it high up. The ball traversed along a path in a vertical plane and the equation of the path is $y = ax^2 + bx + c$ with respect to a xy -coordinate system in the vertical plane and the ball traversed through the points $(10,8), (20,16), (40,22)$, can you conclude that Chennai Super Kings won the match?

Justify your answer. (All distances are measured in metres and the meeting point of the plane of the path with the farthest boundary line is $(70,0)$.)

 [Watch Video Solution](#)

12. Prove that

$$(1 + \cos \theta + i \sin \theta)^n + (1 + \cos \theta - i \sin \theta)^n = 2^{n+1} \cos^n \left(\frac{\theta}{2} \right) \cos \left(\frac{n\theta}{2} \right)$$

 [Watch Video Solution](#)

13. Solve $(x - 4)(x + 2)(x + 3)(x - 3) + 8 = 0$

 [Watch Video Solution](#)

14. Prove that

$$\tan^{-1} \left(\frac{2}{11} \right) + \tan^{-1} \left(\frac{7}{24} \right) = \tan^{-1} \left(\frac{1}{2} \right)$$

 [Watch Video Solution](#)

15. A road bridge over an irrigation canal have two semi circular vents each with a span of 20 m and the supporting pillars of width 2m. Use

figure to write the equations that represent the semi verticalar vents.

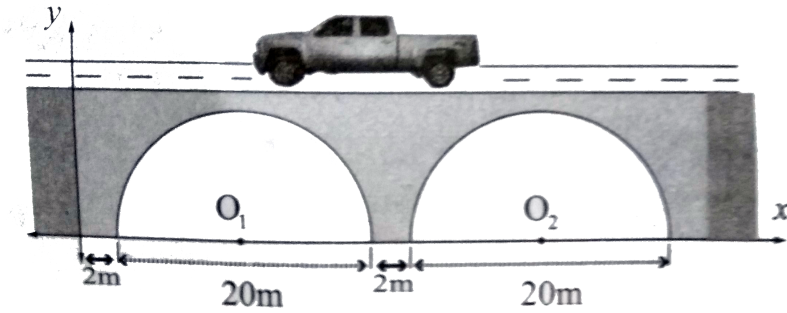

[Watch Video Solution](#)

16. Show that the set $G = \{a + b\sqrt{2}/a, b \in \mathbb{Q}\}$ is an infinite abelian group with respect to Binary operation addition. Satisfies closure, associative, identity and inverse properties.

[Watch Video Solution](#)

17. Find the parametric form of vector equation, and Cartesian equations of the plane containing the line $\vec{r}(\hat{i} - \hat{j} + 3\hat{k}) + t(2\hat{i} - \hat{j} + 4\hat{k})$ and perpendicular to the plane $\vec{r} \cdot (\hat{i} + 2\hat{j} + \hat{k}) = 8$.



Watch Video Solution

18. The mean and standard deviation of a binomial variate X are respectively 6 and 2. Find (i) the probability mass function (ii) $P(X=3)$ (iii) $P(X \geq 2)$.



Watch Video Solution

19. Find the intervals of concavity and the points of inflection of the function. $y = 12x^2 - 2x^3 - x^4$



Watch Video Solution

20. For each of the functions find the f_x , f_y , and show that $f_{xy} = f_{yx}$.

$$f(x, y) = \tan^{-1} \left(\frac{x}{y} \right)$$



Watch Video Solution

21. $\frac{dy}{dx} + \frac{y}{x} = \sin x$

 [Watch Video Solution](#)

22. Evaluate: $\int_{\pi/6}^{\pi/3} \frac{dx}{1 + \sqrt{\cot x}}$

 [Watch Video Solution](#)