



PHYSICS

NCERT - NCERT PHYSICS(TELUGU)

LAW OF MOTION

Example

1. An astronaut accidentally gets separated out of his small spaceship accelerating in inter stellar space at a constant rate of $100ms^{-2}$.

What is the acceleration of the astronaut the instant after he is outside the spaceship ?
(Assume that there are no nearby stars to exert gravitational force on him.)



[Watch Video Solution](#)

2. A bullet of mass 0.04 kg moving with a speed of 90 m s^{-1} enters a heavy wooden block and is stopped after a distance of 60 cm .
What is the average resistive force exerted by the block on the bullet?



Watch Video Solution

3. The motion of a particle of mass m is described by $y = ut + \frac{1}{2}gt^2$. Find the force acting on the particle.



Watch Video Solution

4. A batsman hits back a ball straight in the direction of the bowler without changing its initial speed of $12ms^{-1}$. If the mass of the ball

is 0.15 kg, determine the impulse imparted to the ball. (Assume linear motion of the ball)



Watch Video Solution

5. Two identical billiard balls strike a rigid wall with the same speed but at different angles, and get reflected without any change in speed, as shown in Fig. 5.6. What is (i) the direction of the force on the wall due to each ball? (ii) the ratio of the magnitudes of impulses imparted

to the balls by the wall ?

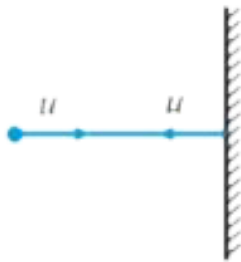

(a)

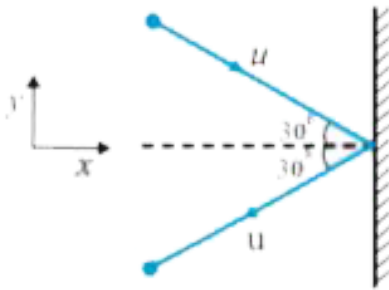

(b)



Watch Video Solution

6. See Fig. A mass of 6 kg is suspended by a rope of length 2 m from the ceiling. A force of 50 N in the horizontal direction is applied at the mid-point P of the rope, as shown. What is the angle the rope makes with the vertical in

equilibrium ? (Take $g = 10\text{ms}^{-2}$). Neglect the mass of the rope.

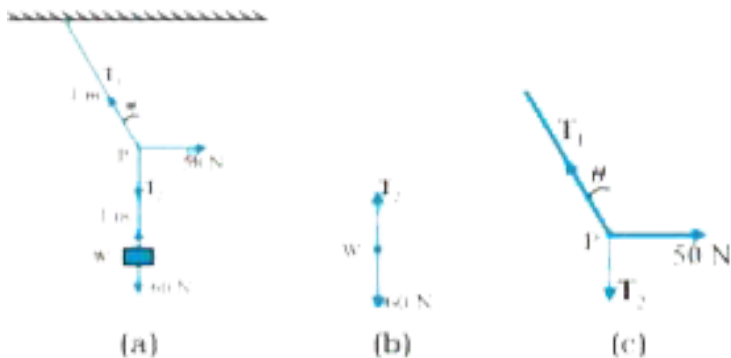

[View Text Solution](#)

7. Determine the maximum acceleration of the train in which a box lying on its floor will remain stationary, given that the co-efficient of

static friction between the box and the train's floor is 0.15.



[Watch Video Solution](#)

8. See Fig. A mass of 4 kg rests on a horizontal plane. The plane is gradually inclined until at an angle $\theta = 15^\circ$ with the horizontal, the mass just begins to slide. What is the coefficient of static friction between the block

and the surface ?

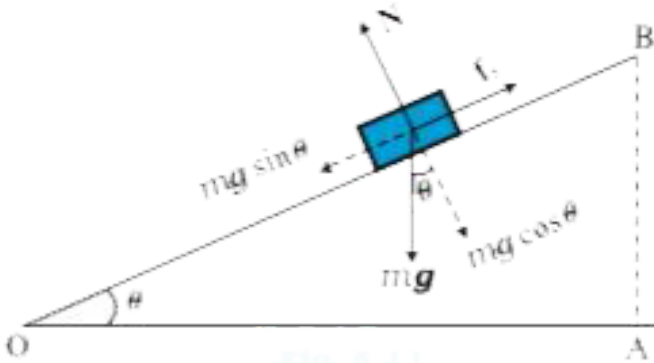

Fig. 8.11



[Watch Video Solution](#)

9. What is the acceleration of the block and trolley system shown in a Fig.(a), if the coefficient of kinetic friction between the trolley and the surface is 0.04? What is the tension in the string? (Take $g = 10m.s^{-2}$).

Neglect the mass of the string.

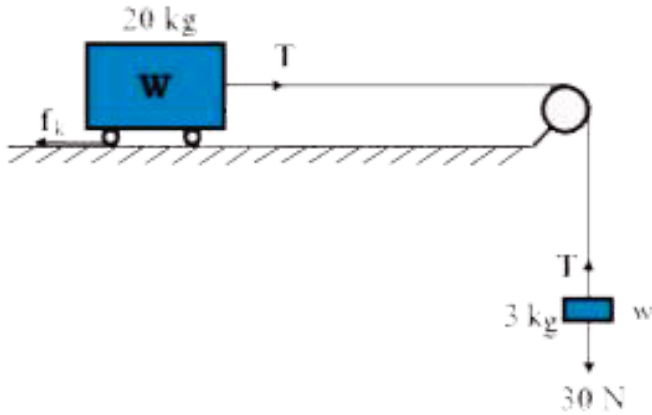

(a)



(b)



(c)

 [Watch Video Solution](#)

10. A cyclist speeding at 18 km/h on a level road takes a sharp circular turn of radius 3 m

without reducing the speed. The co-efficient of static friction between the tyres and the road is 0.1. Will the cyclist slip while taking the turn?



[Watch Video Solution](#)

11. A circular racetrack of radius 300 m is banked at an angle of 15° . If the coefficient of friction between the wheels of a race-car and the road is 0.2, what is the (a) optimum speed of the race- car to avoid wear and tear on its

tyres, and (b) maximum permissible speed to avoid slipping ?



[Watch Video Solution](#)

12. A wooden block of mass 2 kg rests on a soft horizontal floor. When an iron cylinder of mass 25 kg is placed on top of the block, the floor yields steadily and the block and the cylinder together go down with an acceleration of $0.1ms^{-2}$. What is the action of the block on the floor (a) before and (b) after the floor

yields ? Take $g = 10\text{ms}^{-2}$. Identify the action-reaction pairs in the problem.



[View Text Solution](#)

Exercise

1. Give the magnitude and direction of the net force acting on (a) a drop of rain falling down with a constant speed, (b) a cork of mass 10 g floating on water, (c) a kite skillfully held stationary in the sky, (d) a car moving with a

constant velocity of 30 km/h on a rough road,
(e) a high-speed electron in space far from all material objects, and free of electric and magnetic fields.



Watch Video Solution

2. A pebble of mass 0.05 kg is thrown vertically upwards. Give the direction and magnitude of the net force on the pebble, (a) during its upward motion, (b) during its downward motion, (c) at the highest point where it is

momentarily at rest. Do your answers change if the pebble was thrown at an angle of 45° with the horizontal direction? Ignore air resistance.



[Watch Video Solution](#)

3. Give the magnitude and direction of the net force acting on a stone of mass 0.1 kg, (a) just after it is dropped from the window of a stationary train, (b) just after it is dropped from the window of a train running at a

constant velocity of 36 km/h, (c) just after it is dropped from the window of a train accelerating with 1ms^{-2} , (d) lying on the floor of a train which is accelerating with 1ms^{-2} , the stone being at rest relative to the train. Neglect air resistance throughout.



[Watch Video Solution](#)

4. One end of a string of length l is connected to a particle of mass m and the other to a small peg on a smooth horizontal table. If the

particle moves in a circle with speed v the net force on the particle (directed towards the centre) is :

$$(i)T, (ii)T - \frac{mv^2}{l}, (iii)T + \frac{mv^2}{l}, (iv)0$$

T is the tension in the string. [Choose the correct alternative].



Watch Video Solution

5. A constant retarding force of 50 N is applied to a body of mass 20 kg moving initially with

a speed of 15ms^{-1} . How long does the body take to stop ?



[Watch Video Solution](#)

6. A constant force acting on a body of mass 3.0 kg changes its speed from 2.0ms^{-1} to 3.5ms^{-1} in 25 s . The direction of the motion of the body remains unchanged. What is the magnitude and direction of the force ?



[Watch Video Solution](#)

7. A body of mass 5 kg is acted upon by two perpendicular forces 8 N and 6 N . Give the magnitude and direction of the acceleration of the body .



[Watch Video Solution](#)

8. The driver of a three -wheeler moving with a speed of 36 km/ h sees a child standing in the middle of the road and brings his vehicle to rest in 4. 0 s just in time to save the child . What is the average retarding force on the

vehicle ? The mass of the three wheeler is 400 kg and the mass of the driver is 65 kg .



[Watch Video Solution](#)

9. A rocket with a lift -off mass 20 , 000 kg is blasted upwards with an initial acceleration of 5.0ms^{-2} . Calculate the initial thrust (force) of the blast .



[Watch Video Solution](#)

10. A body of mass 0.40 kg moving initially with a constant speed of 10 m s^{-1} to the north is subject to a constant force of 8.0 N directed towards the south for 30 s . Take the instant the force is applied to be $t = 0$, the position of the body at that time to be $x = 0$, and predict its position at $t = -5 \text{ s}$, 25 s , 100 s .



Watch Video Solution

11. A truck starts from rest and accelerates uniformly at 2.0ms^{-2} . At $t = 10\text{ s}$, a stone is dropped by a person standing on the top of the truck (6 m high from the ground). What are the (a) velocity, and (b) acceleration of the stone at $t = 11\text{s}$? (Neglect air resistance.)



Watch Video Solution

12. A bob of mass 0.1 kg hung from the ceiling of a room by a string 2 m long is set into

oscillation. The speed of the bob at its mean position is 1ms^{-1} . What is the trajectory of the bob if the string is cut when the bob is (a) at one of its extreme positions, (b) at its mean position.



[Watch Video Solution](#)

13. A man of mass 70 kg stands on a weighing scale in a lift which is moving (a) upwards with a uniform speed of 10ms^{-1} , (b) downwards with a uniform acceleration of 5ms^{-2} , (c)

upwards with a uniform acceleration of 5ms^{-2} . What would be the readings on the scale in each case? (d) What would be the reading if the lift mechanism failed and it hurtled down freely under gravity?



[Watch Video Solution](#)

14. Figure shows the position-time graph of a particle of mass 4 kg. What is the (a) force on the particle for $t < 0$, $t > 4$ s, $0 < t < 4$ s? (b) impulse at $t = 0$ and $t = 4$ s? (Consider one-

dimensional motion only).

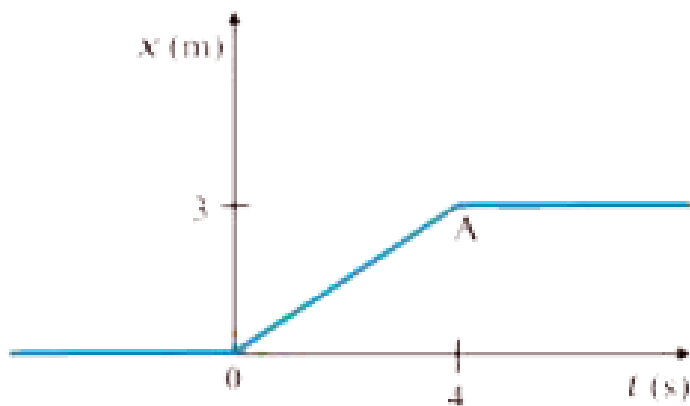

[Watch Video Solution](#)

15. Two bodies of masses 10 kg and 20 kg respectively kept on a smooth , horizontal surface are tied to the ends of a light string a horizontal force $F = 600$ N is applied to (i) A,

(ii) B along the direction of string What is the tension in the string in each case ?



Watch Video Solution

16. Two masses 8 kg and 12 kg are connected at the two ends of a light inextensible string that goes over a frictionless pulley. Find the acceleration of the masses, and the tension in the string when the masses are released.



Watch Video Solution

17. A nucleus is at rest in the laboratory frame of reference. Show that if it disintegrates into two smaller nuclei the products must move in opposite directions.



[Watch Video Solution](#)

18. Two billiard balls each of mass 0.05 kg moving in opposite directions with speed 6 m s^{-1} collide and rebound with the same speed. What is the impulse imparted to each ball due to the other?



[Watch Video Solution](#)

19. A shell of mass 0.020 kg is fired by a gun of mass 100 kg . If the muzzle speed of the shell is 80ms^{-1} , what is the recoil speed of the gun ?



[Watch Video Solution](#)

20. A batsman deflects a ball by an angle of 45° without changing its initial speed which is equal to 54 km/h . What is the impulse

imparted to the ball ? (Mass of the ball is 0.15 kg.)



[Watch Video Solution](#)

21. A stone of mass 0.25 kg tied to the end of a string is whirled round in a circle of radius 1.5 m with a speed of 40 rev./min in a horizontal plane. What is the tension in the string ? What is the maximum speed with which the stone can be whirled around if the string can withstand a maximum tension of 200 N ?



22. If, the speed of the stone is increased beyond the maximum permissible value, and the string breaks suddenly, which of the following correctly describes the trajectory of the stone after the string breaks : (a) the stone moves radially outwards, (b) the stone flies off tangentially from the instant the string breaks, (c) the stone flies off at an angle with the tangent whose magnitude depends on the speed of the particle ?



[Watch Video Solution](#)

23. Explain why (a) a horse cannot pull a cart and run in empty space, (b) passengers are thrown forward from their seats when a speeding bus stops suddenly, (c) it is easier to pull a lawn mower than to push it, (d) a cricketer moves his hands backwards while holding a catch.



[Watch Video Solution](#)

Exercise Additional Exercise

1. Figure shows the position-time graph of a body of mass 0.04 kg . Suggest a suitable physical context for this motion. What is the time between two consecutive impulses received by the body? What is the magnitude of each impulse?



[View Text Solution](#)

2. Figure shows a man standing stationary with respect to a horizontal conveyor belt that is accelerating with 1ms^{-2} . What is the net force on the man? If the coefficient of static friction between the man's shoes and the belt is 0.2, up to what acceleration of the belt can the man continue to be stationary relative to the belt ? (Mass of the man = 65 kg.)

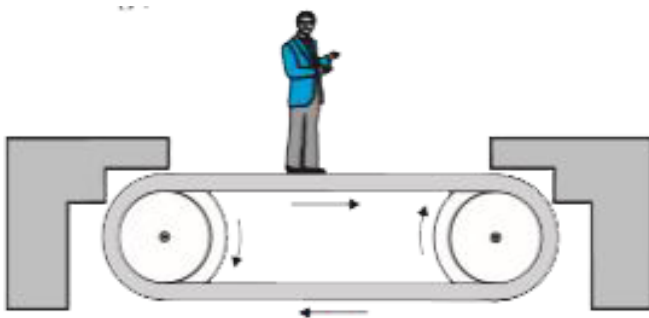

3. A stone of mass m tied to the end of a string revolves in a vertical circle of radius R . The net forces at the lowest and highest points of the circle directed vertically downwards are : [Choose the correct alternative

Lowest Point

(a) $mg - T_1$

(b) $mg + T_1$

(c) $mg + T_1 - (m v_1^2) / R$

(d) $mg - T_1 - (m v_1^2) / R$

Highest Point

$mg + T_2$

$mg - T_2$

$mg - T_2 + (m v_1^2) / R$

$mg + T_2 + (m v_1^2) / R$

T_1 and v_1 denote the tension and speed at the

lowest point. T_2 and v_2 denote corresponding values at the highest point.



[Watch Video Solution](#)

4. A helicopter of mass 1000 kg rises with a vertical acceleration of 15ms^{-2} . The crew and the passengers weigh 300 kg. Give the magnitude and direction of the (a) force on the floor by the crew and passengers, (b) action of the rotor of the helicopter on the

surrounding air, (c) force on the helicopter due to the surrounding air.



[Watch Video Solution](#)

5. A stream of water flowing horizontally with a speed of 15m s^{-1} pushes out of a tube of cross - sectional area 10^{-2}m^2 , and hits a vertical wall nearby . What is the force exerted on the wall by the impact of water , assuming it does not rebound ?



[Watch Video Solution](#)

6. Ten one-rupee coins are put on top of each other on a table. Each coin has a mass m . Give the magnitude and direction of (a) the force on the 7th coin (counted from the bottom) due to all the coins on its top, (b) the force on the 7th coin by the eighth coin, (c) the reaction of the 6th coin on the 7th coin



[Watch Video Solution](#)

7. An aircraft executes a horizontal loop at a speed of 720 km/h with its wings banked at 15° . What is the radius of the loop ?



[Watch Video Solution](#)

8. A train runs along an unbanked circular track of radius 30 m at a speed of 54 km/h. The mass of the train is 10^6 kg. What provides the centripetal force required for this purpose - The engine or the rails ? What is the angle of

banking required to prevent wearing out of the rail ?



[Watch Video Solution](#)

9. A block of mass 25 kg is raised by a 50 kg man in two different ways as shown in Fig. What is the action on the floor by the man in the two cases ? If the floor yields to a normal force of 700 N, which mode should the man adopt to lift the block without the floor

yielding ?

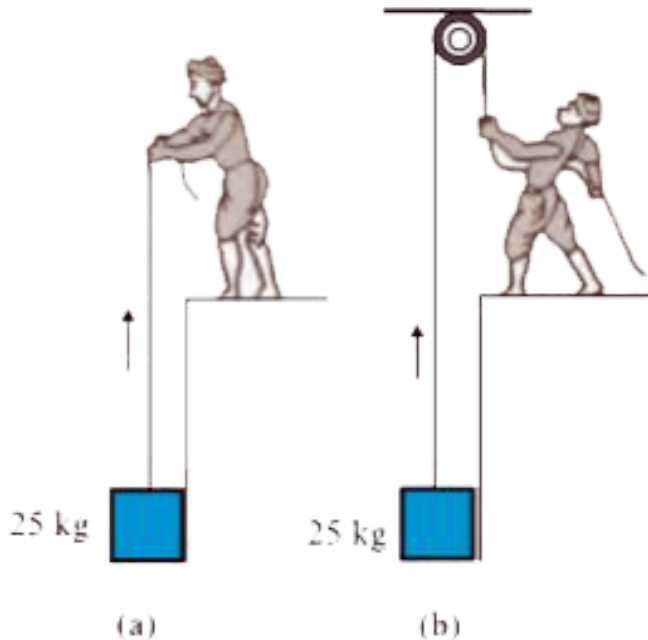

[View Text Solution](#)

10. A monkey of mass 40 kg climbs on a rope. which can stand a maximum tension of 600 N.

In which of the following cases will the rope break: the monkey (a) climbs up with an acceleration of $6ms^{-2}$ (b) climbs down with an acceleration of $4ms^{-2}$ (c) climbs up with a uniform speed of $5ms^{-1}$ (d) falls down the rope nearly freely under gravity? (Ignore the

mass of the rope).

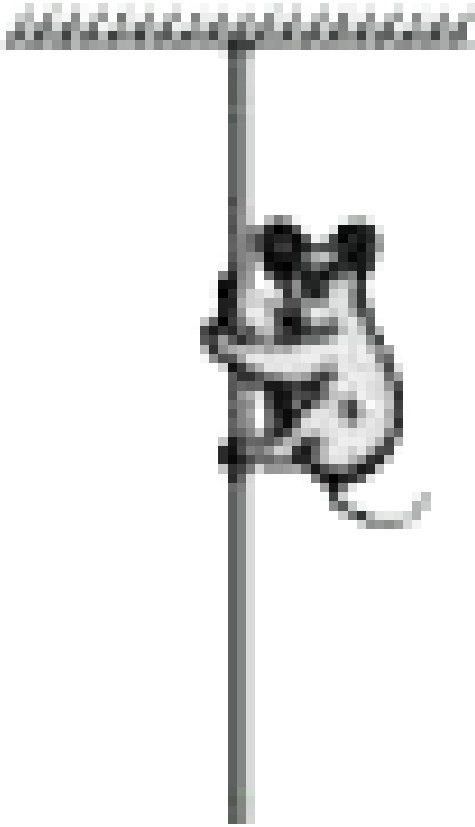

Watch Video Solution

11. Two bodies A and B of masses 5 kg and 10 kg in contact with each other rest on a table against a rigid wall . The coefficient of friction between the bodies and the table is 0.15. A force of 200 N is applied horizontally to A. What are (a) the reaction of the partition (b) the action-reaction forces between A and B ? What happens when the wall is removed? Does the answer to (b) change, when the bodies are in motion? Ignore the difference

between μ_s and μ_k

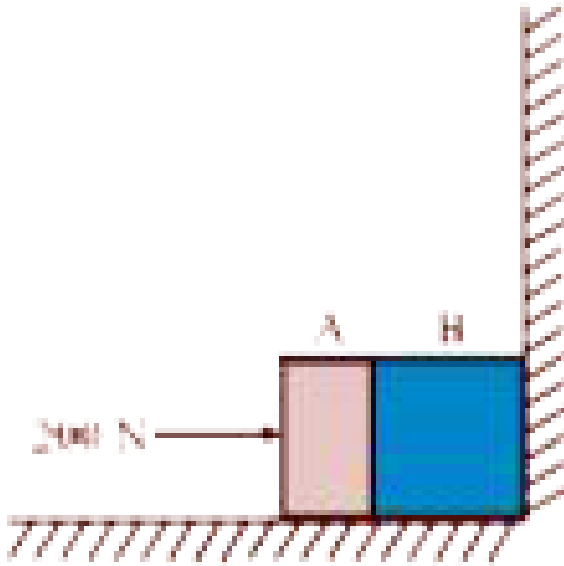

[Watch Video Solution](#)

12. A block of mass 15 kg is placed on a long trolley. The coefficient of static friction between the block and the trolley is 0.18. The

trolley accelerates from rest with 0.5ms^{-2} for 20 s and then moves with uniform velocity. Discuss the motion of the block as viewed by (a) a stationary observer on the ground, (b) an observer moving with the trolley.



[Watch Video Solution](#)

13. The rear side of a truck is open and a box of 40 kg mass is placed 5 m away from the open end as shown in Fig. The coefficient of friction between the box and the surface below it is

0.15. On a straight road, the truck starts from rest and accelerates with 2ms^{-2} . At what distance from the starting point does the box fall off the truck? (Ignore the size of the box).

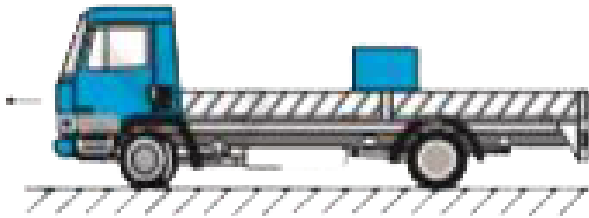

[View Text Solution](#)

14. A disc revolves with a speed of $33/3$ rev/min, and has a radius of 15 cm. Two coins are placed at 4 cm and 14 cm away from the

centre of the record. If the co-efficient of friction between the coins and the record is 0.15, which of the coins will revolve with the record ?



[Watch Video Solution](#)

15. You may have seen in a circus a motorcyclist driving in vertical loops inside a 'death-well' (a hollow spherical chamber with holes, so the spectators can watch from outside). Explain clearly why the motorcyclist

does not drop down when he is at the uppermost point, with no support from below. What is the minimum speed required at the uppermost position to perform a vertical loop if the radius of the chamber is 25 m ?



[Watch Video Solution](#)

16. A 70 kg man stands in contact against the inner wall of a hollow cylindrical drum of radius 3 m rotating about its vertical axis with 200 rev/min. The coefficient of friction

between the wall and his clothing is 0.15. What is the minimum rotational speed of the cylinder to enable the man to remain stuck to the wall (without falling) when the floor is suddenly removed ?



[Watch Video Solution](#)

17. A thin circular loop of radius R rotates about its vertical diameter with an angular frequency ω . Show that a small bead on the wire loop remains at its lowermost point for

$\omega \leq \sqrt{g/R}$. What is the angle made by the radius vector joining the centre to bead with the vertical downward direction for $\omega = \sqrt{2g/R}$? Neglect friction .



Watch Video Solution