



MATHS

BOOKS - NCERT MATHS (ENGLISH)

SURFACE AREAS AND VOLUMES

Multiple Choice Questions

1. A cylindrical pencil sharpened at one edge is the combination of

A. a cone and a cylinder

B. frustum of a cone and a cylinder

C. a hemisphere and a cylinder

D. two cylinders

Answer: A



Watch Video Solution

2. A surahi is the combination of

A. a sphere and a cylinder

B. a hemisphere and a cylinder

C. two hemispheres

D. a cylinder and a cone

Answer: A



Watch Video Solution

3. A plumbline (sahul) is the combination of
(see figure)

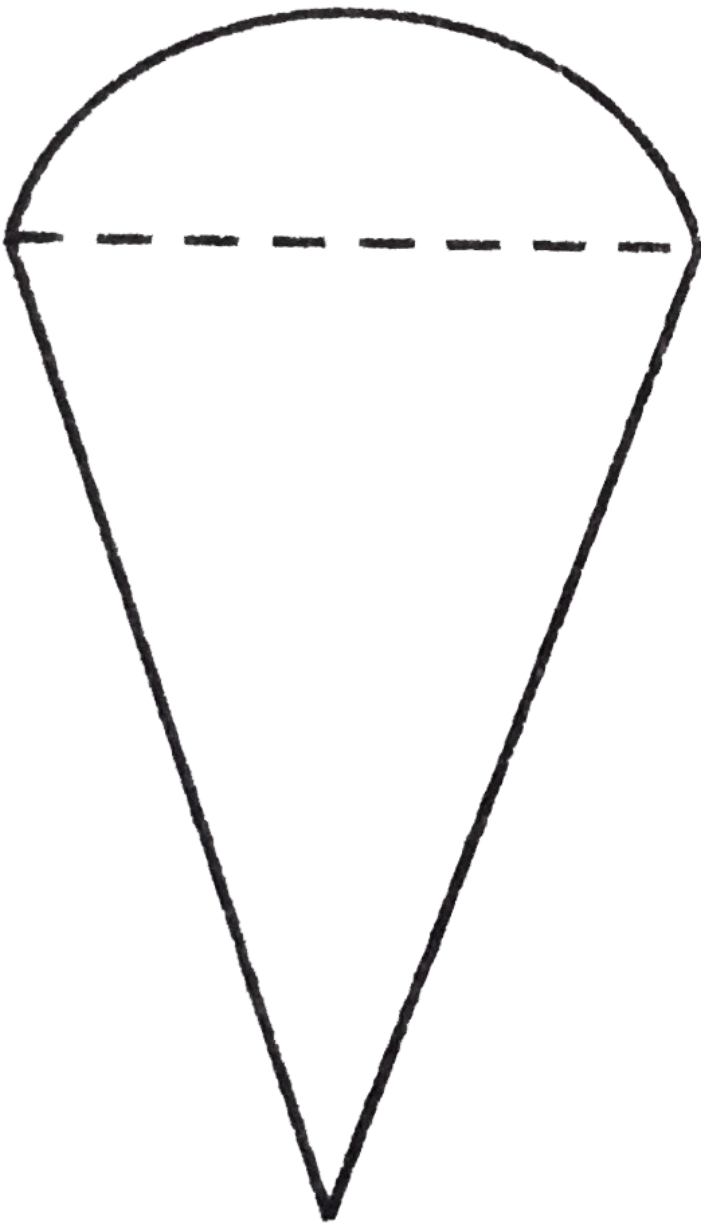

A. a cone and a cylinder

B. a hemisphere and a cone

C. frustum of a cone and a cylinder

D. sphere and cylinder

Answer: B



Watch Video Solution

4. The shape of a glass (tumbler) (see figure)

is usually in the form of

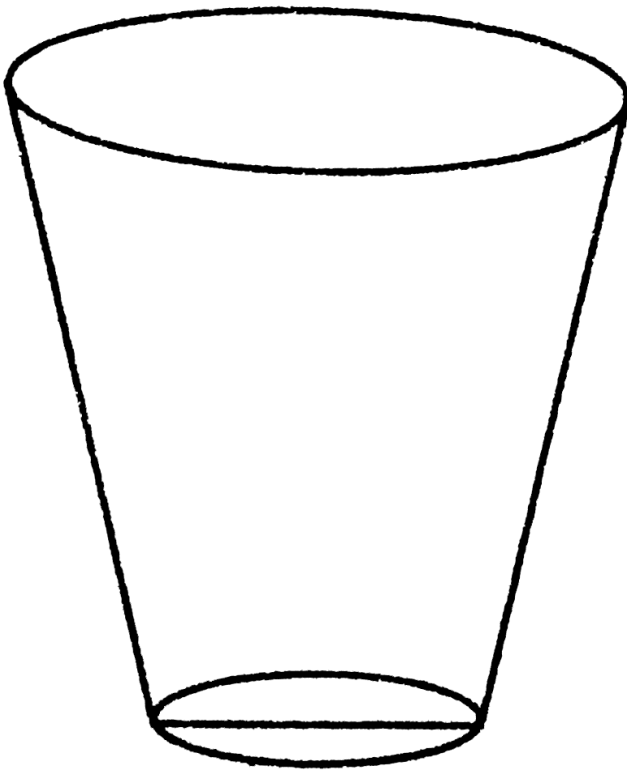

- A. a cone
- B. frustum of a cone
- C. a cylinder
- D. a sphere

Answer: B



Watch Video Solution

5. The shape of a gilli in the gilli-danda game (see figure) is a combination of

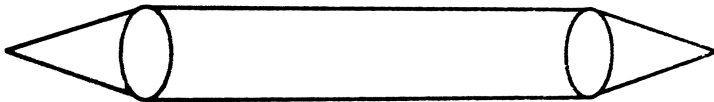

- A. two cylinders
- B. a cone and a cylinder
- C. two cones and a cylinder

D. two cylinders and a cone

Answer: C



Watch Video Solution

6. A shuttle cock used for playing badminton has the shape of the combination of

A. a cylinder and a sphere

B. a cylinder and a hemisphere

C. a sphere and cone

D. frustum of a cone and a hemisphere

Answer: D



Watch Video Solution

7. A cone is cut through a plane parallel to its base and then the cone that is formed on one side of that plane is removed . The new part that is left over on the other side of the plane is called.

A. a frustum of a cone

B. cone

C. cylinder

D. sphere

Answer: A



Watch Video Solution

8. If a hollow cube of internal edge 22 cm is filled with spherical marbles of diameter 0.5 cm and it is assumed that $\frac{1}{8}$ space of the

cube remains unfilled. Then, the number of marbles that the cube can accommodate is

A. 142244

B. 142344

C. 142444

D. 142544

Answer: A



Watch Video Solution

9. A metallic spherical shell of internal and external diameters 4 cm and 8 cm, respectively is melted and recast into the form a cone of base diameter 8 cm. The height of the cone is

A. 12 cm

B. 14 cm

C. 15 cm

D. 18 cm

Answer: B



Watch Video Solution

10. If a solid piece of iron in the form of a cuboid of dimensions $49\text{ cm} \times 33\text{ cm} \times 24\text{ cm}$, is moulded to form a solid sphere. Then, radius of the sphere is

- A. 21 cm
- B. 23 cm
- C. 25 cm
- D. 19 cm

Answer: A



Watch Video Solution

11. A mason constructs a wall of dimension $270\text{ cm} \times 300\text{ cm} \times 350\text{ cm}$ with the bricks each of size $22.5\text{ cm} \times 11.25\text{ cm} \times 8.75\text{ cm}$ and it is assumed that $\frac{1}{8}$ space is covered by the mortar. Then, the number of bricks used to construct the wall is

A. 11100

B. 11200

C. 11000

D. 11300

Answer: B



Watch Video Solution

12. Twelve solid spheres of the same size are made by melting a solid metallic cylinder of base diameter 2 cm and height 16 cm . The diameter of each sphere is .

A. 4 cm

B. 3 cm

C. 2 cm

D. 6 cm

Answer: C



Watch Video Solution

13. The radii of the top and bottom of a bucket of slant height 45 cm are 28 cm and 7 cm

respectively . The curved surface area of the bucket is

A. 4950cm^2

B. 4951cm^2

C. 4952cm^2

D. 4953cm^2

Answer: A



Watch Video Solution

14. A medicine-capsule is the shape of a cylinder of diameter 0.5 cm with two hemisphere stuck to each of its ends. The length of entire capsule is 2 cm . The capacity of the capsule is

A. 0.36cm^3

B. 0.35cm^3

C. 0.34cm^3

D. 0.33cm^3

Answer: A



Watch Video Solution

15. If two solid hemispheres of same base radius r are joined together along their bases, then the curved surface area of the this new solid is

A. $4\pi r^2$

B. $6\pi r^2$

C. $3\pi r^2$

D. $8\pi r^2$

Answer: A



Watch Video Solution

16. A right circular cylinder of radius r cm and height h cm (where , $h > 2r$) just encloses a sphere of diameter

A. r cm

B. $2r$ cm

C. h cm

D. $2h$ cm

Answer: B



Watch Video Solution

17. During conversion of a solid from one shape to another, the volume the new shape will

- A. increase
- B. decrease
- C. remain unaltered
- D. be doubled

Answer: C



Watch Video Solution

18. The diameters of the two circular ends of the bucket are 44 cm and 24 cm . The height of the bucket is 35 cm . The capacity of the bucket is

A. $32.7L$

B. $33.7L$

C. $34.7L$

D. 31.7L

Answer: A



Watch Video Solution

19. In a right circular cone, the cross - section made by a plane parallel to the base is a

- (A) Circle
- (B) Frustum of a cone
- (C) Sphere
- (D) Hemisphere

A. Circle

B. frustum of a cone

C. sphere

D. hemisphere

Answer: B



Watch Video Solution

20. If volume of two spheres are in the ratio
64: 27, then the ratio of their surface area is

A. 3:4

B. 4:3

C. 9:16

D. 16:9

Answer: D



Watch Video Solution

Very Short Answer Type Questions

1. Write True or False and justify your answer:

Two identical solid hemispheres of equal base radius r cm are stuck together along their bases. The total surface area of the combination is $6\pi r^2$.



[Watch Video Solution](#)

2. Write True or False and justify your answer for the following:

A solid cylinder of radius r and height h is

placed over other cylinder same height and radius . The total surface area of the shape so formed is $4\pi rh + 4\pi r^2$.



[Watch Video Solution](#)

3. State True or False and justify your answer

A solid cone of radius r and height h is placed over a solid cylinder having same base radius and height as that of a cone,. The total surface area of the combined solid is

$$\pi \left[\sqrt{r^2 + h^2} + 3r + 2h \right]$$



4. State True or False and justify your answer

A solid ball is exactly fitted inside the cubical

box of side a . The volume of the ball is $\frac{4}{3}\pi a^3$.

A. $\frac{1}{3}\pi a^3$

B. $\frac{4}{3}\pi a^3$

C. $\frac{1}{6}\pi a^3$

D. can not be determined

Answer: C



[Watch Video Solution](#)

5. The volume of the frustum of a cone is $\frac{1}{3}\pi h [r_1^2 + r_2^2 - r_1 r_2]$, where h is vertical height of the frustum and r_1, r_2 are the radii of the ends.



[Watch Video Solution](#)

6. The capacity of a cylinder vessel with a hemisphere portion raised upward at the

bottom as shown in the figure is

$$\frac{\pi r^2}{3} [3h - 2r]$$



[Watch Video Solution](#)

7. The curved surface area of frustum of a cone

is $\pi l (r_1 + r_2)$, where

$l = \sqrt{h^2 + (r_1 - r_2)^2}$, r_1 and r_2 are the

radii of two ends of the frustum and h is the vertical height.



[Watch Video Solution](#)

8. An open metallic bucket is the shape of a frustum of a cone mounted on a hollow cylindrical base made of the same metallic sheet . The surface area of the metallic sheet used is equal to curved surface area of frustum of a cone + area of circular base + curved surface area of cylinder.



[Watch Video Solution](#)

Short Answer Type Questions

1. Three metallic solid cubes whose edges are 3 cm ,4 cm and 5 cm melted and formed into a single cube . Find the edge of the cube formed.



[Watch Video Solution](#)

2. How many shots each having diameter 3 cm can be made form a cuboidal lead solid of dimensions $9\text{cm} \times 11\text{cm} \times 12\text{cm}$?



[Watch Video Solution](#)

3. A bucket is in the form of a frustum of a cone and holds 28.490 litres of water. The radii of the top and bottom are 28 cm and 21 cm respectively. Find the height of the bucket.



[Watch Video Solution](#)

4. A cone of radius 8 cm and height 12 cm is divided into two parts by a plane through the mid-point of its axis parallel to its base. Find the ratio of the volumes of two parts.



[Watch Video Solution](#)

5. 2 cubes each of volume 64 cm^3 are joined end to end. Find the surface area of the resulting cuboid.



[Watch Video Solution](#)

6. From a solid cube of side 7 cm, a conical cavity of height 7 cm and radius 3 is hollowed out. Find the volume of the remaining solid.



[Watch Video Solution](#)

7. Two cones with same base radius 8 cm and height 15 cm are joined together along their bases. Find the surface area of the shape so formed.



[Watch Video Solution](#)

8. Two solid cones A and B are placed in a cylindrical tube as shown in the figure The ratio of their capacities is 2:1 Find the heights

and capacities of cones Also find the volume of the remaining portion of the cylinder. 21 cm



[Watch Video Solution](#)

9. An ice-cream cone full of ice-cream having radius 5 cm height 10 cm as shown in figure.

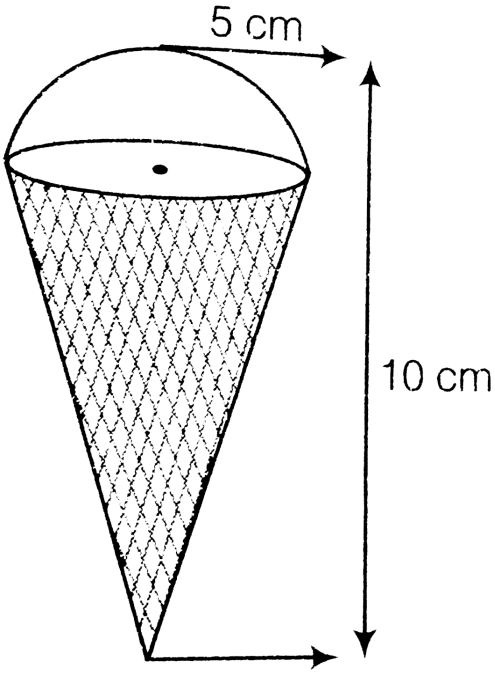

Calculate the volume of ice-cream, provided that its $\frac{1}{6}$ part is left unfilled with ice-cream.



Watch Video Solution

10. Marbles of diameter 1.4 cm are dropped into a cylindrical beaker of diameter 7 cm, containing some water. Find the number of marbles that should be dropped into the beaker so that the water level rises by 5.6 cm.



Watch Video Solution

11. How many spherical lead shots each 4.2 cm in diameter can be obtained from a

rectangular solid of lead with dimensions 66cm, 42cm, 21cm. $\left(use \pi = \frac{22}{7} \right)$.



Watch Video Solution

12. How many spherical bullets can be made out of a solid cube of lead whose edge measures 44 cm, each being 4 cm in diameter.



Watch Video Solution

13. A wall 24 m long, 0.4 m thick and 6 m high is constructed with the bricks each of dimension $25\text{cm} \times 16\text{cm} \times 10\text{cm}$. If the mortar occupies $\frac{1}{10}$ th of the volume of the wall then find the number of bricks used in constructing the wall.



Watch Video Solution

14. Find the number of coins, 1.5 cm in diameter and 0.2 cm thick, to be melted to

form a right circular cylinder of height 10 cm and diameter 4.5 cm.



[Watch Video Solution](#)

Long Answer Type Questions

1. A hemisphere of lead of radius 8cm is cast into a right circular cone of base radius 6cm. Determine the height of the cone, correct to two places of decimal.



[Watch Video Solution](#)

2. A rectangular water tank of base $11\text{m} \times 6\text{m}$ contains water upto a height of 5 m. If the water in the tank is transferred to a cylindrical tank of radius 3.5 m, find the height of the water level in the tank.



[Watch Video Solution](#)

3. How many cubic cm of iron is required to construct open box whose external dimensions are 36 cm 25 cm and 16.5 cm

provided the thickness of the iron is 1.5 cm If one cubic cm of iron weights 7.5 gm then find the weight of the box.



[Watch Video Solution](#)

4. The barrel of a fountain pen, cylindrical in shape, is 7 cm long and 5 *mm* in diameter. A full barrel of ink in the pen is used up on writing 3300 words on an average. How many words can be written in a bottle of ink containing one-fifth of a litre?



[Watch Video Solution](#)

5. Water flows at the rate of 10 meter per minute through a cylindrical pipe having diameter as 5 *mm*. How much time will it take to fill a conical vessel whose diameter of base is 40 *cm* and depth 24 *cm*?



[Watch Video Solution](#)

6. A heap of wheat is in the form of a cone of diameter 9 *m* and height 3.5 *m*. Find its

volume. How much canvas cloth is required to just cover the heap? (Use $\pi = 3.14$)



[Watch Video Solution](#)

7. A factory manufacture 120000 pencils daily. The pencils are cylindrical in shape each of length 25 cm and circumference of base as 1.5 cm. Determine the cost of colouring the curved surface of the pencils manufactured in one day at ₹ 0.25 per dm^2



[Watch Video Solution](#)

8. Water is flowing at the rate of 15 km/hour through a pipe of diameter 14 cm into a cuboidal pond which is 50 m long and 44 m wide. In what time will the level of water in the pond rise by 21 cm ?



Watch Video Solution

9. A solid iron rectangular block of dimensions 4.4 m , 2.6 m and 1 m is cast into a hollow

cylindrical pipe of internal radius 30 cm and thickness 5 cm. Find the length of the pipe.



[Watch Video Solution](#)

10. 500 persons have to dip in a rectangular tank which is 80 m long and 50 m broad. What is the rise in the level of water in the tank, if the average displacement of water by a person is 0.04 m^3 ?



[Watch Video Solution](#)

11. Metal sphere, each of radius 2 cm, are packed into a rectangular box of internal dimension $16\text{cm} \times 8\text{cm} \times 8\text{cm}$. When 16 spheres are packed the box is filled with presrvative liquied .Find the volume of this liquid. Give your answer to the nerest interger. [use $\pi = 3.14$].



Watch Video Solution

12. A milk container of height 16 cm is made of metal sheet in the form of a frustum of a cone

with radii of its lower and upper ends as 8 cm and 20 cm, respectively. Find the cost of milk at the rate of ₹22 per L which the container can hold.



[Watch Video Solution](#)

13. A cylindrical bucket, 32 cm high and with radius of base 18 cm, is filled with sand. This bucket is emptied on the ground and a conical heap of sand is formed. If the height of the

conical heap is 24 cm, find the radius and slant height of the he



[Watch Video Solution](#)

14. A rocket is in the form of a right circular cylinder closed at the lower end and surmounted by a cone with the same radius as that of the cylinder. The diameter and height of the cylinder are 6 cm and 12 cm , respectively. If the slant height of the conical portion is 5 cm,

the find the total surface area and volume of the rocket. (use $\pi = 3.14$).



[Watch Video Solution](#)

15. A bulinding is in the form of a cylinder surmounted by a hemispherical valuted dome and contains $41\frac{19}{21}m^3$ of air. If the internal diameter of dome is equal to its total height above the floor, find the height of the bulinding ?



[Watch Video Solution](#)

16. A hemispherical bowl of internal radius 9 cm is full of liquid . The liquid is to be filled into cylindrical shaped bottles each fo radius 1.5 cm and height 4 cm. How many bottles are needed to empty the bowl?



Watch Video Solution

17. A solid right circular cone of height 120 cm and radius 60 cm is placed in a right circular cylinder full of water of height 180 cm. Such

that it touches the bottom .Find the volume of water of left in the cylinder, if the radius of the cylinder is equal to the radius to the cone.

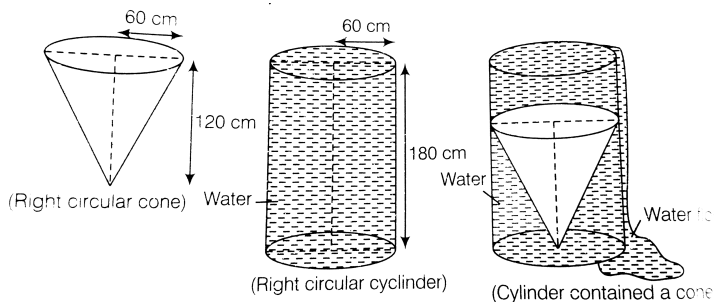

[Watch Video Solution](#)

18. A water flows through a cylindrical pipe, whose inner radius is 1 cm, at the rate of 80cm^{-1} in an empty cylindrical tank, the

radius of whose base is 40 cm. What is the rise of water level in tank in half an hour?



[Watch Video Solution](#)

19. The rain water from a roof of dimensions $22m \times 20m$ drains into a cylindrical vessel having diameter of bases 2 m and height 3.5 m. If the rain water collected from the roof just fill the cylindrical vessel, then find the rainfall (in cm).



[Watch Video Solution](#)

20. A pen stand made of wood is in the shape of a cuboid with four conical depressions and a cubical depression to hold the pens and pins, respectively. The dimension of the cuboid are 10 cm, 5 cm and 4 cm. The radius of the each of the conical depression is 0.5 cm and depth is 2.1 cm . The edge of the conical depression is 3 cm. Find the volume of the wood in the entire stand.



Watch Video Solution

