

JEE April 2019

Roll No.	
Candidate Name	
Application No	
Test Date	08/04/2019
Test Time	2:30 PM - 5:30 PM
Subject	Paper I EH

Section : Physics

- Q.1** A positive point charge is released from rest at a distance r_0 from a positive line charge with uniform density. The speed (v) of the point charge, as a function of instantaneous distance r from line charge, is proportional to :

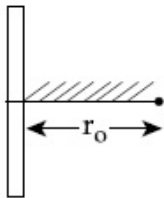

- Options**
1. $v \propto e^{+r/r_0}$
 2. $v \propto \sqrt{\ln\left(\frac{r}{r_0}\right)}$
 3. $v \propto \ln\left(\frac{r}{r_0}\right)$
 4. $v \propto \left(\frac{r}{r_0}\right)$

Question Type : **MCQ**

Question ID : **41652914690**

Option 1 ID : **41652957541**

Option 2 ID : **41652957540**

Option 3 ID : **41652957538**

Option 4 ID : **41652957539**

Status : **Not Answered**

Chosen Option : --

- Q.2** A parallel plate capacitor has $1\mu\text{F}$ capacitance. One of its two plates is given $+2\mu\text{C}$ charge and the other plate, $+4\mu\text{C}$ charge. The potential difference developed across the capacitor is :

- Options**
1. 3 V
 2. 1 V
 3. 5 V
 4. 2 V

Question Type : **MCQ**Question ID : **41652914689**Option 1 ID : **41652957537**Option 2 ID : **41652957534**Option 3 ID : **41652957535**Option 4 ID : **41652957536**Status : **Not Answered**

Chosen Option : --

Q.3 A rocket has to be launched from earth in such a way that it never returns. If E is the minimum energy delivered by the rocket launcher, what should be the minimum energy that the launcher should have if the same rocket is to be launched from the surface of the moon ? Assume that the density of the earth and the moon are equal and that the earth's volume is 64 times the volume of the moon.

Options

1. $\frac{E}{64}$

2. $\frac{E}{32}$

3. $\frac{E}{4}$

4. $\frac{E}{16}$

Question Type : **MCQ**Question ID : **41652914683**Option 1 ID : **41652957510**Option 2 ID : **41652957511**Option 3 ID : **41652957513**Option 4 ID : **41652957512**Status : **Not Answered**

Chosen Option : --

Q.4 The given diagram shows four processes i.e., isochoric, isobaric, isothermal and adiabatic. The correct assignment of the processes, in the same order is given by :

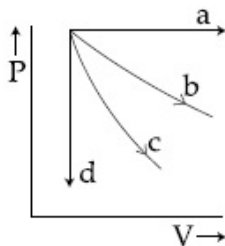

Options 1. a d b c

2. d a c b

3. a d c b

4. d a b c

Question Type : **MCQ**Question ID : **41652914685**Option 1 ID : **41652957519**Option 2 ID : **41652957518**Option 3 ID : **41652957520**Option 4 ID : **41652957521**Status : **Not Answered**

Chosen Option : --

- Q.5** In the circuit shown, a four-wire potentiometer is made of a 400 cm long wire, which extends between A and B. The resistance per unit length of the potentiometer wire is $r = 0.01 \Omega/\text{cm}$. If an ideal voltmeter is connected as shown with jockey J at 50 cm from end A, the expected reading of the voltmeter will be :

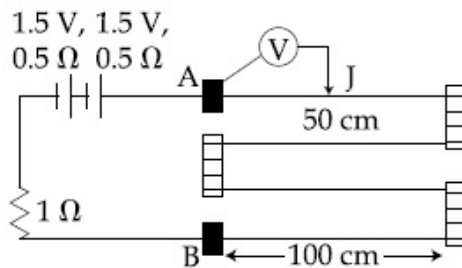

- Options**
1. 0.50 V
 2. 0.75 V
 3. 0.25 V
 4. 0.20 V

Question Type : **MCQ**Question ID : **41652914704**Option 1 ID : **41652957596**Option 2 ID : **41652957597**Option 3 ID : **41652957594**Option 4 ID : **41652957595**Status : **Answered**

Chosen Option : 1

- Q.6** A common emitter amplifier circuit, built using an npn transistor, is shown in the figure. Its dc current gain is 250, $R_C = 1 \text{ k}\Omega$ and $V_{CC} = 10 \text{ V}$. What is the minimum base current for V_{CE} to reach saturation ?

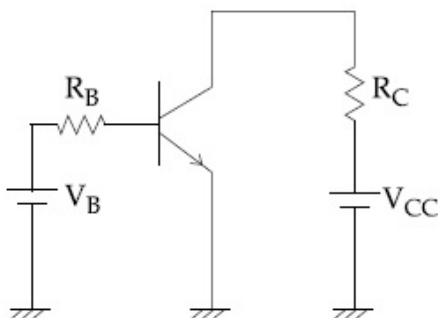

- Options**
1. 40 μA

2. $100 \mu\text{A}$
3. $7 \mu\text{A}$
4. $10 \mu\text{A}$

Question Type : **MCQ**
 Question ID : **41652914702**
 Option 1 ID : **41652957587**
 Option 2 ID : **41652957589**
 Option 3 ID : **41652957588**
 Option 4 ID : **41652957586**
 Status : **Answered**
 Chosen Option : **4**

Q.7 Young's moduli of two wires A and B are in the ratio 7 : 4. Wire A is 2 m long and has radius R. Wire B is 1.5 m long and has radius 2 mm. If the two wires stretch by the same length for a given load, then the value of R is close to :

- Options
1. 1.5 mm
 2. 1.9 mm
 3. 1.7 mm
 4. 1.3 mm

Question Type : **MCQ**
 Question ID : **41652914684**
 Option 1 ID : **41652957515**
 Option 2 ID : **41652957517**
 Option 3 ID : **41652957516**
 Option 4 ID : **41652957514**
 Status : **Answered**
 Chosen Option : **2**

Q.8 A body of mass m_1 moving with an unknown velocity of $v_1 \hat{i}$, undergoes a collinear collision with a body of mass m_2 moving with a velocity $v_2 \hat{i}$. After collision, m_1 and m_2 move with velocities of $v_3 \hat{i}$ and $v_4 \hat{i}$, respectively. If $m_2 = 0.5 m_1$ and $v_3 = 0.5 v_1$, then v_4 is :

- Options
1. $v_4 - \frac{v_2}{2}$
 2. $v_4 - v_2$
 3. $v_4 - \frac{v_2}{4}$
 4. $v_4 + v_2$

Question Type : **MCQ**
 Question ID : **41652914679**

Option 1 ID : 41652957495

Option 2 ID : 41652957494

Option 3 ID : 41652957497

Option 4 ID : 41652957496

Status : Not Attempted and Marked For Review

Chosen Option : --

Q.9 The ratio of mass densities of nuclei of ^{40}Ca and ^{16}O is close to :

- Options
1. 1
 2. 0.1
 3. 5
 4. 2

Question Type : MCQ

Question ID : 41652914701

Option 1 ID : 41652957585

Option 2 ID : 41652957582

Option 3 ID : 41652957583

Option 4 ID : 41652957584

Status : Not Answered

Chosen Option : --

Q.10 A nucleus A, with a finite de-broglie wavelength λ_A , undergoes spontaneous fission into two nuclei B and C of equal mass. B flies in the same direction as that of A, while C flies in the opposite direction with a velocity equal to half of that of B. The de-Broglie wavelengths λ_B and λ_C of B and C are respectively :

- Options
1. $\lambda_A, 2\lambda_A$
 2. $2\lambda_A, \lambda_A$
 3. $\lambda_A, \frac{\lambda_A}{2}$
 4. $\frac{\lambda_A}{2}, \lambda_A$

Question Type : MCQ

Question ID : 41652914700

Option 1 ID : 41652957579

Option 2 ID : 41652957578

Option 3 ID : 41652957581

Option 4 ID : 41652957580

Status : Answered

Chosen Option : 3

Q.11

The temperature, at which the root mean square velocity of hydrogen molecules equals their escape velocity from the earth, is closest to :

[Boltzmann Constant $k_B = 1.38 \times 10^{-23} \text{ J/K}$

Avogadro Number $N_A = 6.02 \times 10^{26} / \text{kg}$

Radius of Earth : $6.4 \times 10^6 \text{ m}$

Gravitational acceleration
on Earth = 10 ms^{-2}]

- Options
1. 800 K
 2. $3 \times 10^5 \text{ K}$
 3. 10^4 K
 4. 650 K

Question Type : **MCQ**

Question ID : **41652914686**

Option 1 ID : **41652957522**

Option 2 ID : **41652957525**

Option 3 ID : **41652957524**

Option 4 ID : **41652957523**

Status : **Not Answered**

Chosen Option : --

Q.12 A convex lens (of focal length 20 cm) and a concave mirror, having their principal axes along the same lines, are kept 80 cm apart from each other. The concave mirror is to the right of the convex lens. When an object is kept at a distance of 30 cm to the left of the convex lens, its image remains at the same position even if the concave mirror is removed. The maximum distance of the object for which this concave mirror, by itself would produce a virtual image would be :

- Options
1. 30 cm
 2. 25 cm
 3. 10 cm
 4. 20 cm

Question Type : **MCQ**

Question ID : **41652914698**

Option 1 ID : **41652957570**

Option 2 ID : **41652957571**

Option 3 ID : **41652957573**

Option 4 ID : **41652957572**

Status : **Answered**

Chosen Option : 1

Q.13

A uniform rectangular thin sheet ABCD of mass M has length a and breadth b , as shown in the figure. If the shaded portion HBGO is cut-off, the coordinates of the centre of mass of the remaining portion will be :

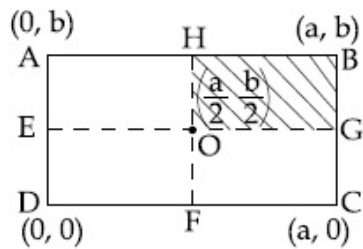

Options

1. $\left(\frac{3a}{4}, \frac{3b}{4}\right)$
2. $\left(\frac{5a}{3}, \frac{5b}{3}\right)$
3. $\left(\frac{2a}{3}, \frac{2b}{3}\right)$
4. $\left(\frac{5a}{12}, \frac{5b}{12}\right)$

Question Type : MCQ

Question ID : 41652914681

Option 1 ID : 41652957504

Option 2 ID : 41652957503

Option 3 ID : 41652957505

Option 4 ID : 41652957502

Status : Answered

Chosen Option : 1

Q.14

In a simple pendulum experiment for determination of acceleration due to gravity (g), time taken for 20 oscillations is measured by using a watch of 1 second least count. The mean value of time taken comes out to be 30 s. The length of pendulum is measured by using a meter scale of least count 1 mm and the value obtained is 55.0 cm. The percentage error in the determination of g is close to :

Options

1. 0.7 %
2. 0.2 %
3. 3.5 %
4. 6.8 %

Question Type : MCQ

Question ID : 41652914705

Option 1 ID : 41652957599

Option 2 ID : 41652957598

Option 3 ID : 41652957600

Option 4 ID : 41652957601

Status : Answered

Chosen Option : 2

Q.15 Calculate the limit of resolution of a telescope objective having a diameter of 200 cm, if it has to detect light of wavelength 500 nm coming from a star.

- Options**
1. 305×10^{-9} radian
 2. 610×10^{-9} radian
 3. 152.5×10^{-9} radian
 4. 457.5×10^{-9} radian

Question Type : **MCQ**Question ID : **41652914699**Option 1 ID : **41652957577**Option 2 ID : **41652957576**Option 3 ID : **41652957574**Option 4 ID : **41652957575**Status : **Answered**Chosen Option : **4**

Q.16 Let $|\vec{A}_1| = 3$, $|\vec{A}_2| = 5$ and $|\vec{A}_1 + \vec{A}_2| = 5$. The value of $(2\vec{A}_1 + 3\vec{A}_2) \cdot (3\vec{A}_1 - 2\vec{A}_2)$ is :

- Options**
1. - 106.5
 2. - 99.5
 3. - 112.5
 4. - 118.5

Question Type : **MCQ**Question ID : **41652914677**Option 1 ID : **41652957487**Option 2 ID : **41652957486**Option 3 ID : **41652957488**Option 4 ID : **41652957489**Status : **Not Answered**

Chosen Option : --

Q.17

Two very long, straight, and insulated wires are kept at 90° angle from each other in xy -plane as shown in the figure.

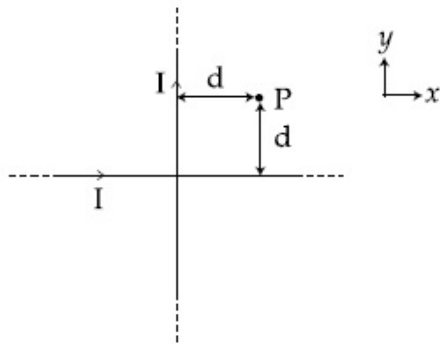

These wires carry currents of equal magnitude I , whose directions are shown in the figure. The net magnetic field at point P will be :

- Options
1. Zero
 2. $-\frac{\mu_0 I}{2\pi d}(\hat{x} + \hat{y})$
 3. $+\frac{\mu_0 I}{\pi d}(\hat{z})$
 4. $\frac{\mu_0 I}{2\pi d}(\hat{x} + \hat{y})$

Question Type : **MCQ**

Question ID : **41652914694**

Option 1 ID : **41652957557**

Option 2 ID : **41652957555**

Option 3 ID : **41652957556**

Option 4 ID : **41652957554**

Status : **Answered**

Chosen Option : **4**

Q.18 A cell of internal resistance r drives current through an external resistance R . The power delivered by the cell to the external resistance will be maximum when :

- Options
1. $R = 0.001 r$
 2. $R = 1000 r$
 3. $R = 2r$
 4. $R = r$

Question Type : **MCQ**

Question ID : **41652914692**

Option 1 ID : **41652957547**

Option 2 ID : **41652957546**

Option 3 ID : **41652957549**

Option 4 ID : **41652957548**

Status : **Answered**

Chosen Option : **4**

Q.19

Two magnetic dipoles X and Y are placed at a separation d , with their axes perpendicular to each other. The dipole moment of Y is twice that of X. A particle of charge q is passing through their midpoint P, at angle $\theta = 45^\circ$ with the horizontal line, as shown in figure. What would be the magnitude of force on the particle at that instant? (d is much larger than the dimensions of the dipole)

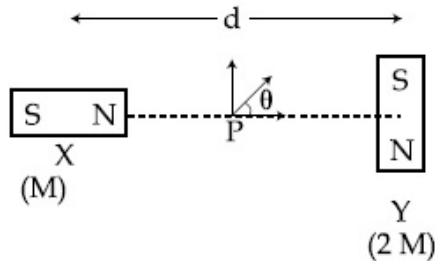

Options

1. $\left(\frac{\mu_0}{4\pi}\right) \frac{M}{(d/2)^3} \times qv$
2. 0
3. $\sqrt{2} \left(\frac{\mu_0}{4\pi}\right) \frac{M}{(d/2)^3} \times qv$
4. $\left(\frac{\mu_0}{4\pi}\right) \frac{2M}{(d/2)^3} \times qv$

Question Type : MCQ

Question ID : 41652914695

Option 1 ID : 41652957559

Option 2 ID : 41652957560

Option 3 ID : 41652957561

Option 4 ID : 41652957558

Status : Answered

Chosen Option : 3

Q.20

In the figure shown, what is the current (in Ampere) drawn from the battery? You are given :

$R_1 = 15 \Omega$, $R_2 = 10 \Omega$, $R_3 = 20 \Omega$, $R_4 = 5 \Omega$,
 $R_5 = 25 \Omega$, $R_6 = 30 \Omega$, $E = 15 \text{ V}$

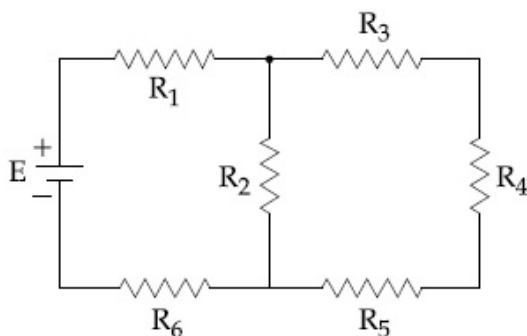

Options

1. 13/24
2. 7/18
3. 9/32
4. 20/3

Question Type : **MCQ**Question ID : **41652914693**Option 1 ID : **41652957551**Option 2 ID : **41652957553**Option 3 ID : **41652957550**Option 4 ID : **41652957552**Status : **Not Answered**

Chosen Option : --

Q.21 A solid sphere and solid cylinder of identical radii approach an incline with the same linear velocity (see figure). Both roll without slipping all throughout. The two climb maximum heights h_{sph} and h_{cyl} on the

incline. The ratio $\frac{h_{sph}}{h_{cyl}}$ is given by :



Options

1. $\frac{2}{\sqrt{5}}$
2. 1
3. $\frac{14}{15}$
4. $\frac{4}{5}$

Question Type : **MCQ**Question ID : **41652914680**Option 1 ID : **41652957499**Option 2 ID : **41652957498**Option 3 ID : **41652957500**Option 4 ID : **41652957501**Status : **Not Answered**

Chosen Option : --

Q.22 The magnetic field of an electromagnetic wave is given by :

$$\vec{B} = 1.6 \times 10^{-6} \cos(2 \times 10^7 z + 6 \times 10^{15} t) (2 \hat{i} + \hat{j}) \frac{\text{Wb}}{\text{m}^2}$$

The associated electric field will be :

Options

1. $\vec{E} = 4.8 \times 10^2 \cos(2 \times 10^7 z - 6 \times 10^{15} t) (2 \hat{i} + \hat{j}) \frac{\text{V}}{\text{m}}$
2. $\vec{E} = 4.8 \times 10^2 \cos(2 \times 10^7 z - 6 \times 10^{15} t) (-2 \hat{j} + \hat{i}) \frac{\text{V}}{\text{m}}$

$$3. \vec{E} = 4.8 \times 10^2 \cos(2 \times 10^7 z + 6 \times 10^{15} t) (-\hat{i} + 2\hat{j}) \frac{V}{m}$$

$$4. \vec{E} = 4.8 \times 10^2 \cos(2 \times 10^7 z + 6 \times 10^{15} t) (\hat{i} - 2\hat{j}) \frac{V}{m}$$

Question Type : **MCQ**Question ID : **41652914697**Option 1 ID : **41652957569**Option 2 ID : **41652957567**Option 3 ID : **41652957566**Option 4 ID : **41652957568**Status : **Answered**

Chosen Option : 1

- Q.23** A rectangular solid box of length 0.3 m is held horizontally, with one of its sides on the edge of a platform of height 5 m. When released, it slips off the table in a very short time $\tau = 0.01$ s, remaining essentially horizontal. The angle by which it would rotate when it hits the ground will be (in radians) close to :

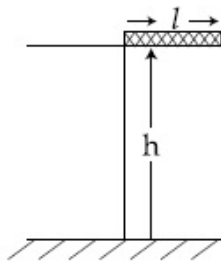

- Options**
1. 0.5
 2. 0.3
 3. 0.02
 4. 0.28

Question Type : **MCQ**Question ID : **41652914682**Option 1 ID : **41652957508**Option 2 ID : **41652957506**Option 3 ID : **41652957507**Option 4 ID : **41652957509**Status : **Answered**

Chosen Option : 1

- Q.24** A circuit connected to an ac source of emf $e = e_0 \sin(100t)$ with t in seconds, gives a phase difference of $\frac{\pi}{4}$ between the emf e and current i . Which of the following circuits will exhibit this ?

- Options**
1. RL circuit with $R = 1 \text{ k}\Omega$ and $L = 10 \text{ mH}$
 2. RL circuit with $R = 1 \text{ k}\Omega$ and $L = 1 \text{ mH}$

3. RC circuit with $R = 1 \text{ k}\Omega$ and $C = 1 \mu\text{F}$
4. RC circuit with $R = 1 \text{ k}\Omega$ and $C = 10 \mu\text{F}$

Question Type : **MCQ**Question ID : **41652914696**Option 1 ID : **41652957564**Option 2 ID : **41652957565**Option 3 ID : **41652957562**Option 4 ID : **41652957563**Status : **Not Answered**

Chosen Option : --

Q.25 In a line of sight radio communication, a distance of about 50 km is kept between the transmitting and receiving antennas. If the height of the receiving antenna is 70 m, then the minimum height of the transmitting antenna should be :
(Radius of the Earth = $6.4 \times 10^6 \text{ m}$).

- Options
1. 20 m
 2. 51 m
 3. 32 m
 4. 40 m

Question Type : **MCQ**Question ID : **41652914703**Option 1 ID : **41652957593**Option 2 ID : **41652957592**Option 3 ID : **41652957591**Option 4 ID : **41652957590**Status : **Answered**Chosen Option : **2**

Q.26 An electric dipole is formed by two equal and opposite charges q with separation d . The charges have same mass m . It is kept in a uniform electric field E . If it is slightly rotated from its equilibrium orientation, then its angular frequency ω is :

- Options
1. $\sqrt{\frac{qE}{md}}$
 2. $\sqrt{\frac{2qE}{md}}$
 3. $2\sqrt{\frac{qE}{md}}$
 4. $\sqrt{\frac{qE}{2md}}$

Question Type : **MCQ**Question ID : **41652914688**Option 1 ID : **41652957532**Option 2 ID : **41652957531**

Option 3 ID : **41652957533**
 Option 4 ID : **41652957530**
 Status : **Not Answered**
 Chosen Option : --

Q.27 The electric field in a region is given by $\vec{E} = (Ax + B)\hat{i}$, where E is in NC^{-1} and x is in metres. The values of constants are $A = 20$ SI unit and $B = 10$ SI unit. If the potential at $x = 1$ is V_1 and that at $x = -5$ is V_2 , then $V_1 - V_2$ is :

- Options
1. 320 V
 2. -48 V
 3. 180 V
 4. -520 V

Question Type : **MCQ**
 Question ID : **41652914691**
 Option 1 ID : **41652957543**
 Option 2 ID : **41652957545**
 Option 3 ID : **41652957544**
 Option 4 ID : **41652957542**
 Status : **Answered**
 Chosen Option : **3**

Q.28 If Surface tension (S), Moment of Inertia (I) and Planck's constant (h), were to be taken as the fundamental units, the dimensional formula for linear momentum would be :

- Options
1. $S^{1/2}I^{3/2}h^{-1}$
 2. $S^{1/2}I^{1/2}h^{-1}$
 3. $S^{1/2}I^{1/2}h^0$
 4. $S^{3/2}I^{1/2}h^0$

Question Type : **MCQ**
 Question ID : **41652914676**
 Option 1 ID : **41652957484**
 Option 2 ID : **41652957485**
 Option 3 ID : **41652957482**
 Option 4 ID : **41652957483**
 Status : **Not Answered**
 Chosen Option : --

Q.29 A damped harmonic oscillator has a frequency of 5 oscillations per second. The amplitude drops to half its value for every 10 oscillations. The time it will take to drop to $\frac{1}{1000}$ of the original amplitude is close to :

- Options
1. 50 s

2. 100 s
3. 20 s
4. 10 s

Question Type : **MCQ**Question ID : **41652914687**Option 1 ID : **41652957527**Option 2 ID : **41652957526**Option 3 ID : **41652957528**Option 4 ID : **41652957529**Status : **Not Answered**

Chosen Option : --

- Q.30** A particle starts from origin O from rest and moves with a uniform acceleration along the positive x - axis. Identify all figures that correctly represent the motion qualitatively.
(a = acceleration, v = velocity, x = displacement, t = time)

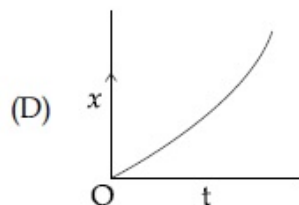
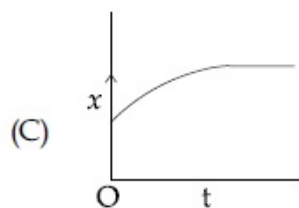
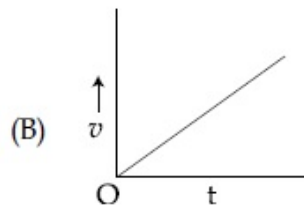
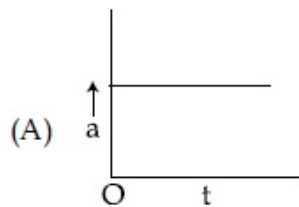

Options 1. (B), (C)

2. (A)
3. (A), (B), (C)
4. (A), (B), (D)

Question Type : **MCQ**Question ID : **41652914678**Option 1 ID : **41652957493**Option 2 ID : **41652957490**

Option 3 ID : **41652957492**
Option 4 ID : **41652957491**
Status : **Not Answered**
Chosen Option : --

Section : Chemistry

Q.1 The compound that inhibits the growth of tumors is :

- Options
1. *trans*-[Pt(Cl)₂(NH₃)₂]
 2. *cis*-[Pd(Cl)₂(NH₃)₂]
 3. *cis*-[Pt(Cl)₂(NH₃)₂]
 4. *trans*-[Pd(Cl)₂(NH₃)₂]

Question Type : **MCQ**
Question ID : **41652914723**
Option 1 ID : **41652957671**
Option 2 ID : **41652957672**
Option 3 ID : **41652957670**
Option 4 ID : **41652957673**
Status : **Answered**
Chosen Option : 1

Q.2 Polysubstitution is a major drawback in :

- Options
1. Friedel Craft's alkylation
 2. Reimer Tiemann reaction
 3. Acetylation of aniline
 4. Friedel Craft's acylation

Question Type : **MCQ**
Question ID : **41652914709**
Option 1 ID : **41652957614**
Option 2 ID : **41652957617**
Option 3 ID : **41652957616**
Option 4 ID : **41652957615**
Status : **Answered**
Chosen Option : 2

Q.3 The percentage composition of carbon by mole in methane is :

- Options
1. 75 %
 2. 80 %
 3. 25 %
 4. 20 %

Question Type : **MCQ**
Question ID : **41652914726**
Option 1 ID : **41652957683**
Option 2 ID : **41652957685**
Option 3 ID : **41652957682**
Option 4 ID : **41652957684**
Status : **Answered**
Chosen Option : 3

Q.4 The IUPAC symbol for the element with atomic number 119 would be :

- Options
1. uue
 2. une
 3. unh
 4. uun

Question Type : **MCQ**

Question ID : **41652914716**

Option 1 ID : **41652957645**

Option 2 ID : **41652957642**

Option 3 ID : **41652957644**

Option 4 ID : **41652957643**

Status : **Answered**

Chosen Option : **4**

Q.5 For the solution of the gases w, x, y and z in water at 298 K, the Henry's law constants (K_H) are 0.5, 2, 35 and 40 kbar, respectively. The correct plot for the given data is :

Options

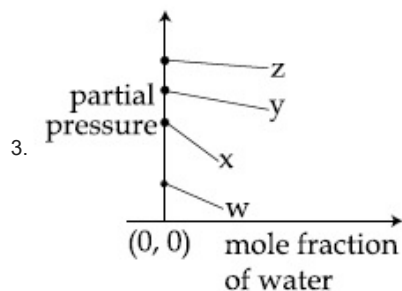
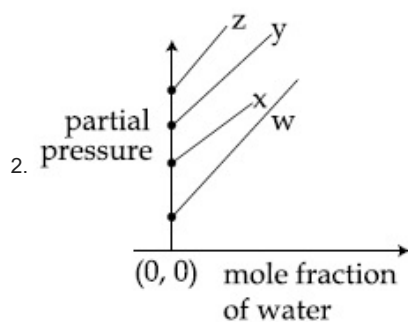
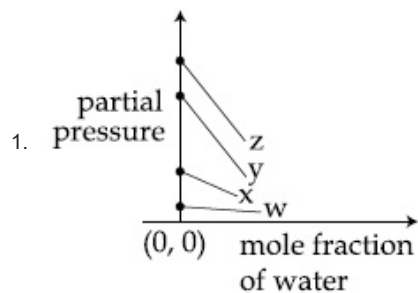

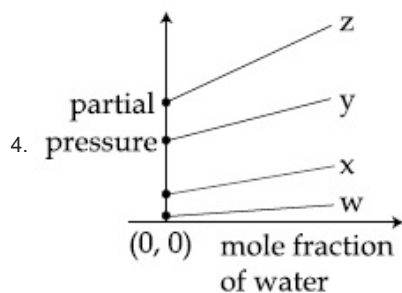

Question Type : MCQ

Question ID : 41652914731

Option 1 ID : 41652957704

Option 2 ID : 41652957703

Option 3 ID : 41652957705

Option 4 ID : 41652957702

Status : Answered

Chosen Option : 4

Q.6 0.27 g of a long chain fatty acid was dissolved in 100 cm^3 of hexane. 10 mL of this solution was added dropwise to the surface of water in a round watch glass. Hexane evaporates and a monolayer is formed. The distance from edge to centre of the watch glass is 10 cm. What is the height of the monolayer ?

[Density of fatty acid = 0.9 g cm^{-3} ; $\pi = 3$]

- Options
1. 10^{-6} m
 2. 10^{-8} m
 3. 10^{-2} m
 4. 10^{-4} m

Question Type : MCQ

Question ID : 41652914735

Option 1 ID : 41652957719

Option 2 ID : 41652957721

Option 3 ID : 41652957720

Option 4 ID : 41652957718

Status : Not Answered

Chosen Option : --

Q.7 Among the following molecules/ions,

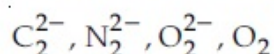

which one is diamagnetic and has the shortest bond length ?

- Options
1. O_2
 2. N_2^{2-}
 3. O_2^{2-}
 4. C_2^{2-}

Question Type : MCQ

Question ID : 41652914729

Option 1 ID : 41652957697

Option 2 ID : 41652957696

Option 3 ID : 41652957694

Option 4 ID : 41652957695

Status : Answered

Chosen Option : 3

Q.8 The major product obtained in the following reaction is :

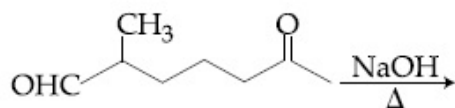

Options

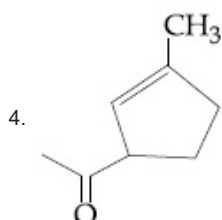
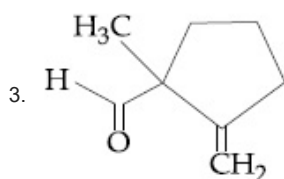
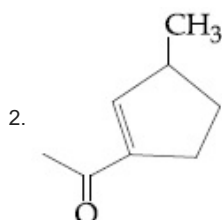
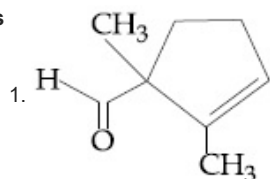

Question Type : MCQ

Question ID : 41652914711

Option 1 ID : 41652957625

Option 2 ID : 41652957623

Option 3 ID : 41652957624

Option 4 ID : 41652957622

Status : Answered

Chosen Option : 1

Q.9 For a reaction scheme $A \xrightarrow{k_1} B \xrightarrow{k_2} C$, if the rate of formation of B is set to be zero then the concentration of B is given by :

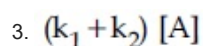
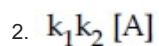
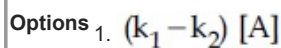

4. $\left(\frac{k_1}{k_2}\right)[A]$

Question Type : **MCQ**

Question ID : **41652914734**

Option 1 ID : **41652957716**

Option 2 ID : **41652957717**

Option 3 ID : **41652957715**

Option 4 ID : **41652957714**

Status : **Answered**

Chosen Option : **3**

Q.10 The correct statement about ICl_5 and ICl_4^- is :

- Options
1. both are isostructural.
 2. ICl_5 is trigonal bipyramidal and ICl_4^- is tetrahedral.
 3. ICl_5 is square pyramidal and ICl_4^- is tetrahedral.
 4. ICl_5 is square pyramidal and ICl_4^- is square planar.

Question Type : **MCQ**

Question ID : **41652914720**

Option 1 ID : **41652957658**

Option 2 ID : **41652957659**

Option 3 ID : **41652957661**

Option 4 ID : **41652957660**

Status : **Answered**

Chosen Option : **2**

Q.11 5 moles of an ideal gas at 100 K are allowed to undergo reversible compression till its temperature becomes 200 K. If $C_V = 28 \text{ J K}^{-1} \text{ mol}^{-1}$, calculate ΔU and ΔpV for this process. ($R = 8.0 \text{ J K}^{-1} \text{ mol}^{-1}$)

- Options
1. $\Delta U = 14 \text{ kJ}$; $\Delta(pV) = 18 \text{ kJ}$
 2. $\Delta U = 14 \text{ J}$; $\Delta(pV) = 0.8 \text{ J}$
 3. $\Delta U = 14 \text{ kJ}$; $\Delta(pV) = 4 \text{ kJ}$
 4. $\Delta U = 2.8 \text{ kJ}$; $\Delta(pV) = 0.8 \text{ kJ}$

Question Type : **MCQ**

Question ID : **41652914730**

Option 1 ID : **41652957698**

Option 2 ID : **41652957699**

Option 3 ID : **41652957700**

Option 4 ID : **41652957701**

Status : **Answered**

Chosen Option : **2**

Q.12 The structure of Nylon-6 is :

Options

1. $\left[(\text{CH}_2)_4 - \overset{\text{O}}{\parallel}{\text{C}} - \overset{\text{H}}{\text{N}} \right]_n$
2. $\left[\overset{\text{O}}{\parallel}{\text{C}} - (\text{CH}_2)_6 - \overset{\text{H}}{\text{N}} \right]_n$
3. $\left[\overset{\text{O}}{\parallel}{\text{C}} - (\text{CH}_2)_5 - \overset{\text{H}}{\text{N}} \right]_n$
4. $\left[(\text{CH}_2)_6 - \overset{\text{O}}{\parallel}{\text{C}} - \overset{\text{H}}{\text{N}} \right]_n$

Question Type : MCQ

Question ID : 41652914706

Option 1 ID : 41652957604

Option 2 ID : 41652957603

Option 3 ID : 41652957602

Option 4 ID : 41652957605

Status : Answered

Chosen Option : 1

Q.13 Which one of the following alkenes when treated with HCl yields majorly an anti Markovnikov product ?

- Options
1. $\text{CH}_3\text{O} - \text{CH} = \text{CH}_2$
 2. $\text{Cl} - \text{CH} = \text{CH}_2$
 3. $\text{H}_2\text{N} - \text{CH} = \text{CH}_2$
 4. $\text{F}_3\text{C} - \text{CH} = \text{CH}_2$

Question Type : MCQ

Question ID : 41652914715

Option 1 ID : 41652957638

Option 2 ID : 41652957640

Option 3 ID : 41652957641

Option 4 ID : 41652957639

Status : Answered

Chosen Option : 1

Q.14 The major product of the following reaction is :

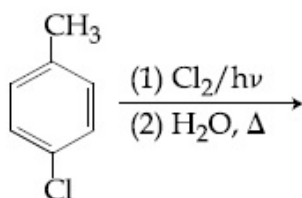

- Options
- 1.

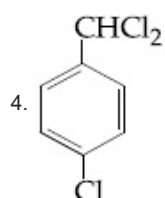
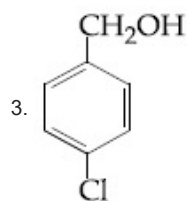
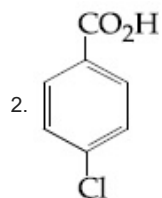

Question Type : **MCQ**

Question ID : **41652914712**

Option 1 ID : **41652957627**

Option 2 ID : **41652957629**

Option 3 ID : **41652957626**

Option 4 ID : **41652957628**

Status : **Answered**

Chosen Option : **4**

Q.15 The major product in the following reaction is :

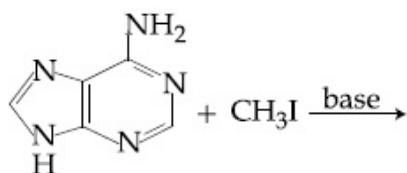

Options

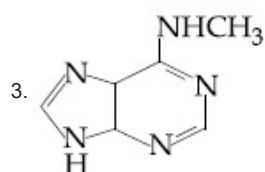
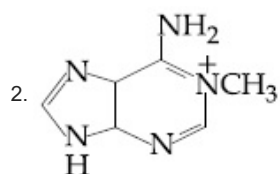
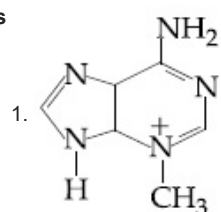

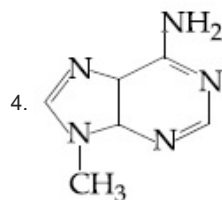

Question Type : **MCQ**
 Question ID : **41652914708**
 Option 1 ID : **41652957612**
 Option 2 ID : **41652957613**
 Option 3 ID : **41652957610**
 Option 4 ID : **41652957611**
 Status : **Not Answered**
 Chosen Option : --

Q.16 Fructose and glucose can be distinguished by :

- Options
1. Benedict's test
 2. Fehling's test
 3. Barfoed's test
 4. Seliwanoff's test

Question Type : **MCQ**
 Question ID : **41652914710**
 Option 1 ID : **41652957619**
 Option 2 ID : **41652957618**
 Option 3 ID : **41652957620**
 Option 4 ID : **41652957621**
 Status : **Answered**
 Chosen Option : **3**

Q.17 The Mond process is used for the :

- Options
1. purification of Ni
 2. extraction of Mo
 3. purification of Zr and Ti
 4. extraction of Zn

Question Type : **MCQ**
 Question ID : **41652914717**
 Option 1 ID : **41652957648**
 Option 2 ID : **41652957647**
 Option 3 ID : **41652957649**
 Option 4 ID : **41652957646**
 Status : **Answered**
 Chosen Option : **3**

Q.18 The covalent alkaline earth metal halide ($X = \text{Cl}, \text{Br}, \text{I}$) is :

- Options
1. MgX_2
 2. CaX_2
 3. BeX_2

4. SrX_2 Question Type : **MCQ**Question ID : **41652914719**Option 1 ID : **41652957655**Option 2 ID : **41652957656**Option 3 ID : **41652957654**Option 4 ID : **41652957657**Status : **Answered**Chosen Option : **1**

Q.19 The ion that has sp^3d^2 hybridization for the central atom, is :

- Options
1. $[\text{ICl}_4]^-$
 2. $[\text{ICl}_2]^-$
 3. $[\text{IF}_6]^-$
 4. $[\text{BrF}_2]^-$

Question Type : **MCQ**Question ID : **41652914721**Option 1 ID : **41652957663**Option 2 ID : **41652957665**Option 3 ID : **41652957664**Option 4 ID : **41652957662**Status : **Answered**Chosen Option : **3**

Q.20 For the following reactions, equilibrium constants are given :

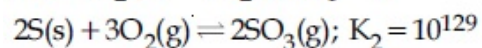
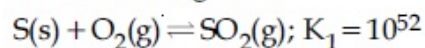

The equilibrium constant for the reaction,

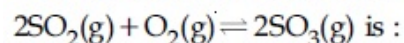

- Options
1. 10^{154}
 2. 10^{181}
 3. 10^{25}
 4. 10^{77}

Question Type : **MCQ**Question ID : **41652914732**Option 1 ID : **41652957708**Option 2 ID : **41652957707**Option 3 ID : **41652957709**Option 4 ID : **41652957706**Status : **Answered**Chosen Option : **4****Q.21**

If p is the momentum of the fastest electron ejected from a metal surface after the irradiation of light having wavelength λ , then for $1.5 p$ momentum of the photoelectron, the wavelength of the light should be :

(Assume kinetic energy of ejected photoelectron to be very high in comparison to work function) :

Options

1. $\frac{3}{4}\lambda$
2. $\frac{1}{2}\lambda$
3. $\frac{2}{3}\lambda$
4. $\frac{4}{9}\lambda$

Question Type : **MCQ**

Question ID : **41652914728**

Option 1 ID : **41652957692**

Option 2 ID : **41652957690**

Option 3 ID : **41652957691**

Option 4 ID : **41652957693**

Status : **Answered**

Chosen Option : **1**

Q.22 The statement that is **INCORRECT** about the interstitial compounds is :

- Options
1. they are chemically reactive.
 2. they are very hard.
 3. they have metallic conductivity.
 4. they have high melting points.

Question Type : **MCQ**

Question ID : **41652914722**

Option 1 ID : **41652957669**

Option 2 ID : **41652957667**

Option 3 ID : **41652957668**

Option 4 ID : **41652957666**

Status : **Answered**

Chosen Option : **4**

Q.23

Consider the bcc unit cells of the solids 1 and 2 with the position of atoms as shown below. The radius of atom B is twice that of atom A. The unit cell edge length is 50% more in solid 2 than in 1. What is the approximate packing efficiency in solid 2?

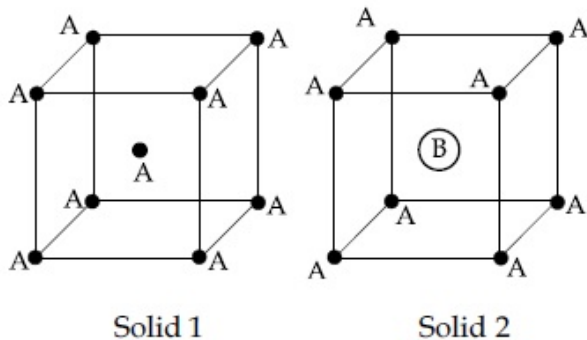

- Options
1. 45%
 2. 75%
 3. 90%
 4. 65%

Question Type : **MCQ**

Question ID : **41652914727**

Option 1 ID : **41652957689**

Option 2 ID : **41652957687**

Option 3 ID : **41652957686**

Option 4 ID : **41652957688**

Status : **Answered**

Chosen Option : **2**

Q.24 The calculated spin-only magnetic moments (BM) of the anionic and cationic species of $[\text{Fe}(\text{H}_2\text{O})_6]_2$ and $[\text{Fe}(\text{CN})_6]$, respectively, are :

- Options
1. 0 and 4.9
 2. 2.84 and 5.92
 3. 4.9 and 0
 4. 0 and 5.92

Question Type : **MCQ**

Question ID : **41652914724**

Option 1 ID : **41652957676**

Option 2 ID : **41652957677**

Option 3 ID : **41652957674**

Option 4 ID : **41652957675**

Status : **Answered**

Chosen Option : **4**

Q.25 The maximum prescribed concentration of copper in drinking water is :

- Options
1. 5 ppm

2. 0.05 ppm
3. 0.5 ppm
4. 3 ppm

Question Type : **MCQ**
 Question ID : **41652914725**
 Option 1 ID : **41652957681**
 Option 2 ID : **41652957679**
 Option 3 ID : **41652957678**
 Option 4 ID : **41652957680**
 Status : **Answered**
 Chosen Option : **3**

Q.26 Which of the following compounds will show the maximum 'enol' content ?

- Options
1. $\text{CH}_3\text{COCH}_2\text{COOC}_2\text{H}_5$
 2. $\text{CH}_3\text{COCH}_2\text{COCH}_3$
 3. CH_3COCH_3
 4. $\text{CH}_3\text{COCH}_2\text{CONH}_2$

Question Type : **MCQ**
 Question ID : **41652914714**
 Option 1 ID : **41652957635**
 Option 2 ID : **41652957634**
 Option 3 ID : **41652957636**
 Option 4 ID : **41652957637**
 Status : **Answered**
 Chosen Option : **1**

Q.27 Calculate the standard cell potential (in V) of the cell in which following reaction takes place :

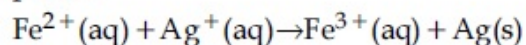

Given that

$$E_{\text{Ag}^+/\text{Ag}}^{\circ} = x \text{ V}$$

$$E_{\text{Fe}^{2+}/\text{Fe}}^{\circ} = y \text{ V}$$

$$E_{\text{Fe}^{3+}/\text{Fe}}^{\circ} = z \text{ V}$$

- Options
1. $x - z$
 2. $x - y$
 3. $x + 2y - 3z$
 4. $x + y - z$

Question Type : **MCQ**
 Question ID : **41652914733**
 Option 1 ID : **41652957711**
 Option 2 ID : **41652957710**
 Option 3 ID : **41652957713**
 Option 4 ID : **41652957712**

Status : **Not Answered**
Chosen Option : --

Q.28 The major product obtained in the following reaction is :

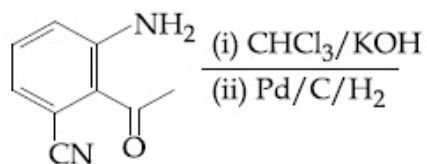

Options

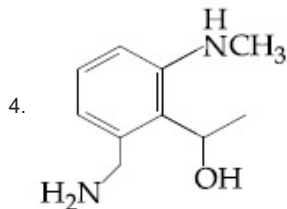
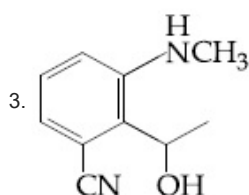
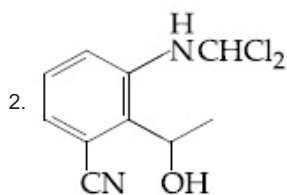
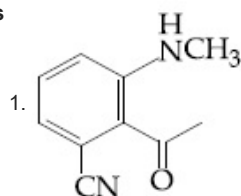

Question Type : **MCQ**

Question ID : **41652914707**

Option 1 ID : **41652957607**

Option 2 ID : **41652957606**

Option 3 ID : **41652957609**

Option 4 ID : **41652957608**

Status : **Not Answered**

Chosen Option : --

Q.29 The major product of the following reaction is :

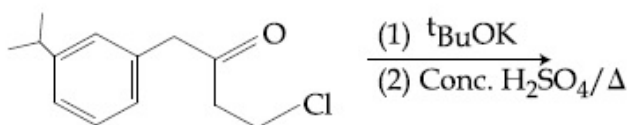

Options

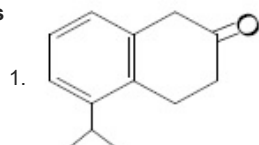

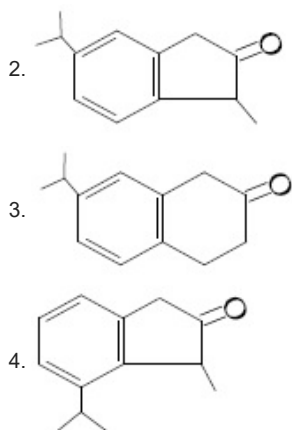
Question Type : **MCQ**Question ID : **41652914713**Option 1 ID : **41652957631**Option 2 ID : **41652957632**Option 3 ID : **41652957633**Option 4 ID : **41652957630**Status : **Not Answered**

Chosen Option : --

Q.30 The strength of 11.2 volume solution of H_2O_2 is : [Given that molar mass of $\text{H} = 1 \text{ g mol}^{-1}$ and $\text{O} = 16 \text{ g mol}^{-1}$]

Options 1. 13.6%

2. 3.4%

3. 34%

4. 1.7%

Question Type : **MCQ**Question ID : **41652914718**Option 1 ID : **41652957650**Option 2 ID : **41652957651**Option 3 ID : **41652957653**Option 4 ID : **41652957652**Status : **Answered**Chosen Option : **4**

Section : Mathematics

Q.1 A student scores the following marks in five tests : 45, 54, 41, 57, 43. His score is not known for the sixth test. If the mean score is 48 in the six tests, then the standard deviation of the marks in six tests is :

Options

1. $\frac{10}{\sqrt{3}}$ 2. $\frac{100}{3}$ 3. $\frac{10}{3}$

4. $\frac{100}{\sqrt{3}}$

Question Type : **MCQ**

Question ID : **41652914761**

Option 1 ID : **41652957824**

Option 2 ID : **41652957822**

Option 3 ID : **41652957823**

Option 4 ID : **41652957825**

Status : **Answered**

Chosen Option : **1**

Q.2 If

$$\int \frac{dx}{x^3(1+x^6)^{2/3}} = xf(x)(1+x^6)^{1/3} + C$$

where C is a constant of integration, then the function $f(x)$ is equal to :

Options

1. $\frac{3}{x^2}$

2. $-\frac{1}{6x^3}$

3. $-\frac{1}{2x^2}$

4. $-\frac{1}{2x^3}$

Question Type : **MCQ**

Question ID : **41652914749**

Option 1 ID : **41652957777**

Option 2 ID : **41652957774**

Option 3 ID : **41652957775**

Option 4 ID : **41652957776**

Status : **Not Answered**

Chosen Option : **--**

Q.3

The vector equation of the plane through the line of intersection of the planes $x + y + z = 1$ and $2x + 3y + 4z = 5$ which is perpendicular to the plane $x - y + z = 0$ is :

Options

1. $\vec{r} \times (\hat{i} - \hat{k}) + 2 = 0$

2. $\vec{r} \cdot (\hat{i} - \hat{k}) - 2 = 0$

3. $\vec{r} \times (\hat{i} + \hat{k}) + 2 = 0$

4. $\vec{r} \cdot (\hat{i} - \hat{k}) + 2 = 0$

Question Type : **MCQ**

Question ID : **41652914758**

Option 1 ID : **41652957811**

Option 2 ID : **41652957812**

Option 3 ID : **41652957810**
 Option 4 ID : **41652957813**
 Status : **Answered**
 Chosen Option : **4**

Q.4 Two vertical poles of heights, 20 m and 80 m stand apart on a horizontal plane. The height (in meters) of the point of intersection of the lines joining the top of each pole to the foot of the other, from this horizontal plane is :

- Options
1. 15
 2. 18
 3. 12
 4. 16

Question Type : **MCQ**
 Question ID : **41652914764**
 Option 1 ID : **41652957835**
 Option 2 ID : **41652957837**
 Option 3 ID : **41652957834**
 Option 4 ID : **41652957836**
 Status : **Not Answered**
 Chosen Option : **--**

Q.5 Suppose that the points (h, k) , $(1, 2)$ and $(-3, 4)$ lie on the line L_1 . If a line L_2 passing through the points (h, k) and $(4, 3)$ is perpendicular to L_1 , then $\frac{k}{h}$ equals :

- Options
1. $\frac{1}{3}$
 2. 0
 3. 3
 4. $-\frac{1}{7}$

Question Type : **MCQ**
 Question ID : **41652914754**
 Option 1 ID : **41652957794**
 Option 2 ID : **41652957796**
 Option 3 ID : **41652957795**
 Option 4 ID : **41652957797**
 Status : **Answered**
 Chosen Option : **2**

Q.6 If the eccentricity of the standard hyperbola passing through the point $(4, 6)$ is 2, then the equation of the tangent to the hyperbola at $(4, 6)$ is :

- Options
1. $x - 2y + 8 = 0$
 2. $2x - 3y + 10 = 0$

3. $2x - y - 2 = 0$

4. $3x - 2y = 0$

Question Type : **MCQ**Question ID : **41652914757**Option 1 ID : **41652957809**Option 2 ID : **41652957808**Option 3 ID : **41652957807**Option 4 ID : **41652957806**Status : **Answered**Chosen Option : **2**

Q.7

Let $\vec{a} = 3\hat{i} + 2\hat{j} + x\hat{k}$ and $\vec{b} = \hat{i} - \hat{j} + \hat{k}$, forsome real x . Then $|\vec{a} \times \vec{b}| = r$ is possible if :

Options

1. $\sqrt{\frac{3}{2}} < r \leq 3\sqrt{\frac{3}{2}}$

2. $r \geq 5\sqrt{\frac{3}{2}}$

3. $0 < r \leq \sqrt{\frac{3}{2}}$

4. $3\sqrt{\frac{3}{2}} < r < 5\sqrt{\frac{3}{2}}$

Question Type : **MCQ**Question ID : **41652914760**Option 1 ID : **41652957819**Option 2 ID : **41652957821**Option 3 ID : **41652957818**Option 4 ID : **41652957820**Status : **Not Answered**Chosen Option : **--**

Q.8

If a point $R(4, y, z)$ lies on the line segment joining the points $P(2, -3, 4)$ and $Q(8, 0, 10)$, then the distance of R from the origin is :

Options

1. $2\sqrt{14}$

2. $2\sqrt{21}$

3. **6**

4. $\sqrt{53}$

Question Type : **MCQ**Question ID : **41652914759**Option 1 ID : **41652957815**Option 2 ID : **41652957816**Option 3 ID : **41652957817**Option 4 ID : **41652957814**Status : **Answered**Chosen Option : **2**

Q.9 If the fourth term in the binomial expansion

of $\left(\sqrt{\frac{1}{x^{1+\log_{10}x}}} + x^{\frac{1}{12}}\right)^6$ is equal to 200, and

$x > 1$, then the value of x is :

- Options**
1. 100
 2. 10
 3. 10^3
 4. 10^4

Question Type : **MCQ**

Question ID : **41652914742**

Option 1 ID : **41652957746**

Option 2 ID : **41652957747**

Option 3 ID : **41652957749**

Option 4 ID : **41652957748**

Status : **Not Answered**

Chosen Option : --

Q.10 Given that the slope of the tangent to a

curve $y=y(x)$ at any point (x,y) is $\frac{2y}{x^2}$. If

the curve passes through the centre of the circle $x^2 + y^2 - 2x - 2y = 0$, then its equation is :

- Options**
1. $x \log_e |y| = 2(x-1)$
 2. $x \log_e |y| = -2(x-1)$
 3. $x^2 \log_e |y| = -2(x-1)$
 4. $x \log_e |y| = x-1$

Question Type : **MCQ**

Question ID : **41652914752**

Option 1 ID : **41652957786**

Option 2 ID : **41652957788**

Option 3 ID : **41652957789**

Option 4 ID : **41652957787**

Status : **Not Answered**

Chosen Option : --

Q.11 Let $f: [-1, 3] \rightarrow \mathbf{R}$ be defined as

$$f(x) = \begin{cases} |x| + [x], & -1 \leq x < 1 \\ x + |x|, & 1 \leq x < 2 \\ x + [x], & 2 \leq x \leq 3, \end{cases}$$

where $[t]$ denotes the greatest integer less than or equal to t . Then, f is discontinuous at :

- Options**
1. only one point
 2. only two points

3. only three points
4. four or more points

Question Type : **MCQ**
 Question ID : **41652914747**
 Option 1 ID : **41652957766**
 Option 2 ID : **41652957767**
 Option 3 ID : **41652957768**
 Option 4 ID : **41652957769**
 Status : **Answered**
 Chosen Option : **1**

Q.12 If $z = \frac{\sqrt{3}}{2} + \frac{i}{2}$ ($i = \sqrt{-1}$), then $(1 + iz + z^5 + iz^8)^9$ is equal to :

- Options
1. 0
 2. 1
 3. $(-1 + 2i)^9$
 4. -1

Question Type : **MCQ**
 Question ID : **41652914737**
 Option 1 ID : **41652957729**
 Option 2 ID : **41652957726**
 Option 3 ID : **41652957728**
 Option 4 ID : **41652957727**
 Status : **Answered**
 Chosen Option : **3**

Q.13 If the lengths of the sides of a triangle are in A.P. and the greatest angle is double the smallest, then a ratio of lengths of the sides of this triangle is :

- Options
1. 5 : 9 : 13
 2. 4 : 5 : 6
 3. 3 : 4 : 5
 4. 5 : 6 : 7

Question Type : **MCQ**
 Question ID : **41652914763**
 Option 1 ID : **41652957831**
 Option 2 ID : **41652957832**
 Option 3 ID : **41652957833**
 Option 4 ID : **41652957830**
 Status : **Answered**
 Chosen Option : **3**

Q.14 The number of integral values of m for which the equation $(1 + m^2)x^2 - 2(1 + 3m)x + (1 + 8m) = 0$ has no real root is :

- Options
1. 1

2. 2
3. infinitely many
4. 3

Question Type : **MCQ**
 Question ID : **41652914738**
 Option 1 ID : **41652957733**
 Option 2 ID : **41652957730**
 Option 3 ID : **41652957732**
 Option 4 ID : **41652957731**
 Status : **Answered**
 Chosen Option : **2**

Q.15 The tangent and the normal lines at the point $(\sqrt{3}, 1)$ to the circle $x^2 + y^2 = 4$ and the x -axis form a triangle. The area of this triangle (in square units) is :

- Options
1. $\frac{4}{\sqrt{3}}$
 2. $\frac{1}{3}$
 3. $\frac{2}{\sqrt{3}}$
 4. $\frac{1}{\sqrt{3}}$

Question Type : **MCQ**
 Question ID : **41652914753**
 Option 1 ID : **41652957790**
 Option 2 ID : **41652957791**
 Option 3 ID : **41652957793**
 Option 4 ID : **41652957792**
 Status : **Answered**
 Chosen Option : **3**

Q.16 If $f(1) = 1$, $f'(1) = 3$, then the derivative of $f(f(f(x))) + (f(x))^2$ at $x = 1$ is :

- Options
1. 33
 2. 12
 3. 15
 4. 9

Question Type : **MCQ**
 Question ID : **41652914746**
 Option 1 ID : **41652957765**
 Option 2 ID : **41652957763**
 Option 3 ID : **41652957764**
 Option 4 ID : **41652957762**
 Status : **Answered**
 Chosen Option : **2**

Q.17

In an ellipse, with centre at the origin, if the difference of the lengths of major axis and minor axis is 10 and one of the foci is at $(0, 5\sqrt{3})$, then the length of its latus rectum is :

- Options
1. 10
 2. 5
 3. 8
 4. 6

Question Type : **MCQ**
Question ID : **41652914756**
Option 1 ID : **41652957803**
Option 2 ID : **41652957804**
Option 3 ID : **41652957802**
Option 4 ID : **41652957805**
Status : **Not Answered**
Chosen Option : --

Q.18 If three distinct numbers a, b, c are in G.P. and the equations $ax^2 + 2bx + c = 0$ and $dx^2 + 2ex + f = 0$ have a common root, then which one of the following statements is correct ?

- Options
1. $\frac{d}{a}, \frac{e}{b}, \frac{f}{c}$ are in A.P.
 2. d, e, f are in A.P.
 3. d, e, f are in G.P.
 4. $\frac{d}{a}, \frac{e}{b}, \frac{f}{c}$ are in G.P.

Question Type : **MCQ**
Question ID : **41652914743**
Option 1 ID : **41652957753**
Option 2 ID : **41652957751**
Option 3 ID : **41652957750**
Option 4 ID : **41652957752**
Status : **Answered**
Chosen Option : **3**

Q.19 The number of four-digit numbers strictly greater than 4321 that can be formed using the digits 0, 1, 2, 3, 4, 5 (repetition of digits is allowed) is :

- Options
1. 288
 2. 360
 3. 306
 4. 310

Question Type : **MCQ**
Question ID : **41652914741**

Option 1 ID : 41652957744
 Option 2 ID : 41652957743
 Option 3 ID : 41652957745
 Option 4 ID : 41652957742
 Status : Answered
 Chosen Option : 1

Q.20

Let $f(x) = \int_0^x g(t)dt$, where g is a non-zero even function. If $f(x+5) = g(x)$, then

$\int_0^x f(t)dt$ equals :

Options

1. $\int_{x+5}^5 g(t)dt$
2. $\int_5^{x+5} g(t)dt$
3. $2 \int_5^{x+5} g(t)dt$
4. $5 \int_{x+5}^5 g(t)dt$

Question Type : MCQ
 Question ID : 41652914750
 Option 1 ID : 41652957778
 Option 2 ID : 41652957779
 Option 3 ID : 41652957780
 Option 4 ID : 41652957781
 Status : Answered
 Chosen Option : 3

Q.21

The sum $\sum_{k=1}^{20} k \frac{1}{2^k}$ is equal to :

Options

1. $2 - \frac{3}{2^{17}}$
2. $1 - \frac{11}{2^{20}}$
3. $2 - \frac{11}{2^{19}}$
4. $2 - \frac{21}{2^{20}}$

Question Type : MCQ
 Question ID : 41652914744
 Option 1 ID : 41652957757
 Option 2 ID : 41652957756
 Option 3 ID : 41652957754
 Option 4 ID : 41652957755
 Status : Answered

Chosen Option : 2

Q.22 Let the numbers 2, b, c be in an A.P. and

$$A = \begin{bmatrix} 1 & 1 & 1 \\ 2 & b & c \\ 4 & b^2 & c^2 \end{bmatrix}. \text{ If } \det(A) \in [2, 16], \text{ then } c$$

lies in the interval :

- Options
1. [2, 3]
 2. $(2 + 2^{3/4}, 4)$
 3. [4, 6]
 4. $[3, 2 + 2^{3/4}]$

Question Type : MCQ

Question ID : 41652914739

Option 1 ID : 41652957736

Option 2 ID : 41652957737

Option 3 ID : 41652957735

Option 4 ID : 41652957734

Status : Not Answered

Chosen Option : --

Q.23 The height of a right circular cylinder of maximum volume inscribed in a sphere of radius 3 is :

- Options
1. $\sqrt{6}$
 2. $\frac{2}{3}\sqrt{3}$
 3. $2\sqrt{3}$
 4. $\sqrt{3}$

Question Type : MCQ

Question ID : 41652914748

Option 1 ID : 41652957772

Option 2 ID : 41652957770

Option 3 ID : 41652957771

Option 4 ID : 41652957773

Status : Answered

Chosen Option : 2

Q.24 The tangent to the parabola $y^2 = 4x$ at the point where it intersects the circle $x^2 + y^2 = 5$ in the first quadrant, passes through the point :

- Options
1. $\left(-\frac{1}{3}, \frac{4}{3}\right)$
 2. $\left(\frac{1}{4}, \frac{3}{4}\right)$

3. $\left(\frac{3}{4}, \frac{7}{4}\right)$

4. $\left(-\frac{1}{4}, \frac{1}{2}\right)$

Question Type : **MCQ**Question ID : **41652914755**Option 1 ID : **41652957798**Option 2 ID : **41652957801**Option 3 ID : **41652957800**Option 4 ID : **41652957799**Status : **Not Answered**

Chosen Option : --

Q.25 The minimum number of times one has to toss a fair coin so that the probability of observing at least one head is at least 90% is :

Options 1. 5

2. 3

3. 4

4. 2

Question Type : **MCQ**Question ID : **41652914762**Option 1 ID : **41652957829**Option 2 ID : **41652957827**Option 3 ID : **41652957828**Option 4 ID : **41652957826**Status : **Answered**

Chosen Option : 4

Q.26 Let $f : \mathbb{R} \rightarrow \mathbb{R}$ be a differentiable function satisfying $f'(3) + f'(2) = 0$. Then

$$\lim_{x \rightarrow 0} \left(\frac{1 + f(3+x) - f(3)}{1 + f(2-x) - f(2)} \right)^{\frac{1}{x}}$$
 is equal to :

Options 1. 1

2. e^{-1} 3. e 4. e^2 Question Type : **MCQ**Question ID : **41652914745**Option 1 ID : **41652957759**Option 2 ID : **41652957760**Option 3 ID : **41652957758**Option 4 ID : **41652957761**Status : **Not Answered**

Chosen Option : --

Q.27

Let $S(\alpha) = \{(x, y) : y^2 \leq x, 0 \leq x \leq \alpha\}$ and $A(\alpha)$ is area of the region $S(\alpha)$. If for a $\lambda, 0 < \lambda < 4$, $A(\lambda) : A(4) = 2 : 5$, then λ equals :

Options

1. $2\left(\frac{4}{25}\right)^{\frac{1}{3}}$

2. $2\left(\frac{2}{5}\right)^{\frac{1}{3}}$

3. $4\left(\frac{2}{5}\right)^{\frac{1}{3}}$

4. $4\left(\frac{4}{25}\right)^{\frac{1}{3}}$

Question Type : **MCQ**

Question ID : **41652914751**

Option 1 ID : **41652957785**

Option 2 ID : **41652957784**

Option 3 ID : **41652957783**

Option 4 ID : **41652957782**

Status : **Answered**

Chosen Option : **4**

Q.28 Which one of the following statements is not a tautology ?

Options 1. $(p \vee q) \rightarrow (p \vee (\sim q))$

2. $(p \wedge q) \rightarrow (\sim p) \vee q$

3. $p \rightarrow (p \vee q)$

4. $(p \wedge q) \rightarrow p$

Question Type : **MCQ**

Question ID : **41652914765**

Option 1 ID : **41652957840**

Option 2 ID : **41652957841**

Option 3 ID : **41652957839**

Option 4 ID : **41652957838**

Status : **Answered**

Chosen Option : **2**

Q.29 If the system of linear equations

$$x - 2y + kz = 1$$

$$2x + y + z = 2$$

$$3x - y - kz = 3$$

has a solution (x, y, z) , $z \neq 0$, then (x, y) lies on the straight line whose equation is :

Options 1. $3x - 4y - 1 = 0$

2. $4x - 3y - 4 = 0$

3. $4x - 3y - 1 = 0$

4. $3x - 4y - 4 = 0$

Question Type : **MCQ**Question ID : **41652914740**Option 1 ID : **41652957739**Option 2 ID : **41652957741**Option 3 ID : **41652957738**Option 4 ID : **41652957740**Status : **Not Answered**

Chosen Option : --

Q.30 Let $f(x) = a^x$ ($a > 0$) be written as $f(x) = f_1(x) + f_2(x)$, where $f_1(x)$ is an even function and $f_2(x)$ is an odd function. Then $f_1(x+y) + f_1(x-y)$ equals :

- Options**
1. $2f_1(x)f_1(y)$
 2. $2f_1(x+y)f_1(x-y)$
 3. $2f_1(x)f_2(y)$
 4. $2f_1(x+y)f_2(x-y)$

Question Type : **MCQ**Question ID : **41652914736**Option 1 ID : **41652957722**Option 2 ID : **41652957723**Option 3 ID : **41652957724**Option 4 ID : **41652957725**Status : **Not Answered**

Chosen Option : --